



State of West Virginia
 Department of Administration
 Purchasing Division
 2019 Washington Street East
 Post Office Box 50130
 Charleston, WV 25305-0130

Request for Quotation

RFQ NUMBER
707EC013

PAGE
1

ADDRESS: CORRESPONDENCE TO ATTENTION OF
JOHN JOHNSTON
304-558-2402

VENDOR

*321105507 585-346-3040
TENCO USA INC
5700 SOUTH LIMA RD
PO BOX 635
LAKEVILLE NY 14480

SHIP TO

DIVISION OF HIGHWAYS
EQUIPMENT DIVISION
ROUTE 33
BRUSHY FORK ROAD
BUCKHANNON, WV
26201 **304-472-1750**

DATE PRINTED 10/25/2006	TERMS OF SALE	SHIP VIA	F.O.B.	FREIGHT TERMS
-----------------------------------	---------------	----------	--------	---------------

BID OPENING DATE: **11/22/2006** BID OPENING TIME **01:30PM**

LINE	QUANTITY	UOP	CAT. NO.	ITEM NUMBER	UNIT PRICE	AMOUNT
0001	1	EA		765-61	32,158.00	32,158.00
<p>FRONT WING MOUNTED SNOWPLOW (LEFT, CENTER, RIGHT)</p> <p>OPEN END CONTRACT</p> <p>TO PROVIDE FRONT WING MOUNTED SNOWPLOW (LEFT, CENTER, RIGHT) AS DESCRIBED IN THE ATTACHED SPECIFICATION 019-1-B.</p> <p>A MANDATORY PRE-BID WILL BE HELD ON 11/9/06 AT 10:00 AT 2019 WASHINGTON STREET EAST, CHARLESTON, WV. FAILURE TO ATTEND THE PRE-BID WILL RESULT IN DISQUALIFICATION OF THE BID. NO ONE PERSON CAN REPRESENT MORE THAN ONE BIDDER.</p> <p>EXHIBIT 2</p> <p>LIFE OF CONTRACT: THIS CONTRACT BECOMES EFFECTIVE ON AND EXTENDS FOR A PERIOD OF ONE (1) YEAR OR UNTIL SUCH "REASONABLE TIME" THEREAFTER AS IS NECESSARY TO OBTAIN A NEW CONTRACT OR RENEW THE ORIGINAL CONTRACT. THE "REASONABLE TIME" PERIOD SHALL NOT EXCEED TWELVE (12) MONTHS. DURING THIS "REASONABLE TIME" THE VENDOR MAY TERMINATE THIS CONTRACT FOR ANY REASON UPON GIVING THE DIRECTOR OF PURCHASING THIRTY (30) DAYS WRITTEN NOTICE.</p> <p>UNLESS SPECIFIC PROVISIONS ARE STIPULATED IN THIS CONTRACT DOCUMENT, THE TERMS, CONDITIONS, AND PRICING SET HEREIN ARE FIRM FOR THE LIFE OF THE CONTRACT.</p> <p>RENEWAL: THIS CONTRACT MAY BE RENEWED UPON THE MUTUAL WRITTEN CONSENT OF THE SPENDING UNIT AND VENDOR,</p>						

SEE REVERSE SIDE FOR TERMS AND CONDITIONS.

SIGNATURE *Shirley Eston* TELEPHONE **585-346-3040** DATE **11/14/06**

TITLE *Procurement* FEIN **16-1441499** ADDRESS CHANGES TO BE NOTED ABOVE

WHEN RESPONDING TO RFQ INSERT NAME AND ADDRESS IN SPACE ABOVE LABELED 'VENDOR'



State of West Virginia
 Department of Administration
 Purchasing Division
 2019 Washington Street East
 Post Office Box 50130
 Charleston, WV 25305-0130

Request for Quotation

RFQ NUMBER
 707EC013

PAGE
 2

ADDRESS CORRESPONDENCE TO ATTENTION OF:
 JOHN JOHNSTON
 304-558-2402

VENDOR

*321105507 585-346-3040
 TENCO USA INC
 5700 SOUTH LIMA RD
 PO BOX 635
 LAKEVILLE NY 14480

SHIP TO

DIVISION OF HIGHWAYS
 EQUIPMENT DIVISION
 ROUTE 33
 BRUSHY FORK ROAD
 BUCKHANNON, WV
 26201 304-472-1750

DATE PRINTED 10/25/2006	TERMS OF SALE	SHIP VIA	F.O.B.	FREIGHT TERMS
----------------------------	---------------	----------	--------	---------------

BID OPENING DATE: 11/22/2006 BID OPENING TIME 01:30PM

LINE	QUANTITY	UOP	CAT NO	ITEM NUMBER	UNIT PRICE	AMOUNT
<p>SUBMITTED TO THE DIRECTOR OF PURCHASING THIRTY (30) DAYS PRIOR TO THE EXPIRATION DATE. SUCH RENEWAL SHALL BE IN ACCORDANCE WITH THE TERMS AND CONDITIONS OF THE ORIGINAL CONTRACT AND SHALL BE LIMITED TO TWO (2) ONE (1) YEAR PERIODS.</p> <p>CANCELLATION: THE DIRECTOR OF PURCHASING RESERVES THE RIGHT TO CANCEL THIS CONTRACT IMMEDIATELY UPON WRITTEN NOTICE TO THE VENDOR IF THE COMMODITIES AND/OR SERVICES SUPPLIED ARE OF AN INFERIOR QUALITY OR DO NOT CONFORM WITH THE SPECIFICATIONS OF THE BID AND CONTRACT HEREIN.</p> <p>OPEN MARKET CLAUSE: THE DIRECTOR OF PURCHASING MAY AUTHORIZE A SPENDING UNIT TO PURCHASE ON THE OPEN MARKET, WITHOUT THE FILING OF A REQUISITION OR COST ESTIMATE, ITEMS SPECIFIED ON THIS CONTRACT FOR IMMEDIATE DELIVERY IN EMERGENCIES DUE TO UNFORESEEN CAUSES (INCLUDING BUT NOT LIMITED TO DELAYS IN TRANSPORTATION OR AN UNANTICIPATED INCREASE IN THE VOLUME OF WORK).</p> <p>QUANTITIES: QUANTITIES LISTED IN THE REQUISITION ARE APPROXIMATIONS ONLY, BASED ON ESTIMATES SUPPLIES BY THE STATE SPENDING UNIT. IT IS UNDERSTOOD AND AGREED THAT THE CONTRACT SHALL COVER THE QUANTITIES ACTUALLY ORDERED FOR DELIVERY DURING THE TERM OF CONTRACT, WHETHER MORE OR LESS THAN THE QUANTITIES SHOWN.</p> <p>ORDERING PROCEDURE: SPENDING UNIT(S) SHALL ISSUE A WRITTEN EQUIPMENT CONTRACT ORDER (FORM NUMBER WV-35) FOR COMMODITIES COVERED BY THIS CONTRACT. THE ORIGINAL WV-35 MUST BE SENT TO THE PURCHASING DIVISION OF THE DEPARTMENT OF ADMINISTRATION. AFTER APPROVAL AND ENCUMBRANCE, ONE COPY OF THE PURCHASE ORDER WILL BE RETURNED TO THE SPENDING UNIT AND ONE COPY FORWARDED TO THE VENDOR AS AUTHORIZATION FOR SHIPMENT. NO ORDER IS VALID UNLESS APPROVED AND ENCUMBERED</p>						

SEE REVERSE SIDE FOR TERMS AND CONDITIONS

SIGNATURE <i>Steven Easton</i>	TELEPHONE 585-346-3040	DATE 11/14/06
TITLE v. pres.	FEIN 16-1441499	ADDRESS CHANGES TO BE NOTED ABOVE

WHEN RESPONDING TO RFQ, INSERT NAME AND ADDRESS IN SPACE ABOVE LABELED 'VENDOR'



State of West Virginia
 Department of Administration
 Purchasing Division
 2019 Washington Street East
 Post Office Box 50130
 Charleston, WV 25305-0130

**Request for
 Quotation**

RFO NUMBER
 707EC013

PAGE
 3

ADDRESS CORRESPONDENCE TO ATTENTION OF
 JOHN JOHNSTON
 304-558-2402

VENDOR

*321105507 585-346-3040
 TENCO USA INC
 5700 SOUTH LIMA RD
 PO BOX 635
 LAKEVILLE NY 14480

SHIP TO

DIVISION OF HIGHWAYS
 EQUIPMENT DIVISION
 ROUTE 33
 BRUSHY FORK ROAD
 BUCKHANNON, WV
 26201 304-472-1750

DATE PRINTED	TERMS OF SALE	SHIP VIA	F.O.B.	FREIGHT TERMS
10/25/2006				

BID OPENING DATE: 11/22/2006 BID OPENING TIME 01:30PM

LINE	QUANTITY	UOP	CAT NO.	ITEM NUMBER	UNIT PRICE	AMOUNT
<p>BY THE PURCHASING DIVISION.</p> <p>BANKRUPTCY: IN THE EVENT THE VENDOR/CONTRACTOR FILES FOR BANKRUPTCY PROTECTION, THIS CONTRACT IS AUTOMATICALLY NULL AND VOID, AND IS TERMINATED WITHOUT FURTHER ORDER.</p> <p>REV. 9/98</p> <p>EXHIBIT 6</p> <p>PRICE ADJUSTMENT PROVISION: THE STATE OF WEST VIRGINIA WILL CONSIDER BIDS THAT CONTAIN PROVISIONS FOR PRICE ADJUSTMENTS PRIOR TO THE ORIGINAL EXPIRATION OF THE CONTRACT, PROVIDED THAT SUCH PRICE ADJUSTMENT COVERS BOTH UPWARD AND DOWNWARD MOVEMENT OF THE COMMODITY PRICE, AND THAT ADJUSTMENT I BASED ON THE "PASS THROUGH" INCREASE OR DECREASE OF RAW MATERIALS AND/OR LABOR, WHICH MAKE UP ALL OR A SUBSTANTIAL PART OF A PRODUCT. ADJUSTMENTS ARE TO BE BASED UPON AN ACTUAL DOLLAR FIGURE, NOT A PERCENTAGE. ALL PRICE ADJUSTMENT REQUESTS MUST BE SUBSTANTIATED IN A MANNER ACCEPTABLE TO THE DIRECTOR PURCHASING, E.G. GOVERNMENTAL BENCH MARKS, GENERAL MARKET INCREASE, PUBLISHED PRICE LISTS. SUCH REQUESTS FOR AND INCREASE SHOULD BE RECEIVED IN WRITING BY THE DIRECTOR OF PURCHASING AT LEAST 30 DAYS IN ADVANCE OF THE EFFECTIVE DATE OF THE INCREASE. ANY TIME THE VENDOR REQUESTS A PRICE ADJUSTMENT, THE PURCHASING DIVISION MAY EITHER ACCEPT THE PRICE ADJUSTMENT AND AMEND THE CONTRACT ACCORDINGLY OR REJECT THE ADJUSTMENT IN ITS ENTIRETY AND CANCEL THE CONTRACT.</p> <p style="text-align: center;">VENDOR PREFERENCE CERTIFICATE</p>						

SEE REVERSE SIDE FOR TERMS AND CONDITIONS

SIGNATURE <i>Steven Easton</i>	TELEPHONE 585-346-3040	DATE 11/14/06
TITLE K. pres.	FEIN 16-1441499	ADDRESS CHANGES TO BE NOTED ABOVE

WHEN RESPONDING TO REQ. INSERT NAME AND ADDRESS IN SPACE ABOVE LABELLED 'VENDOR'



State of West Virginia
 Department of Administration
 Purchasing Division
 2019 Washington Street East
 Post Office Box 50130
 Charleston, WV 25305-0130

Request for Quotation

RFQ NUMBER:
707EC013

PAGE:
4

ADDRESS CORRESPONDENCE TO ATTENTION OF:
JOHN JOHNSTON
304-558-2402

VENDOR

*321105507 585-346-3040
 TENCO USA INC
 5700 SOUTH LIMA RD
 PO BOX 635
 LAKEVILLE NY 14480

SHIP TO

DIVISION OF HIGHWAYS
 EQUIPMENT DIVISION
 ROUTE 33
 BRUSHY FORK ROAD
 BUCKHANNON, WV
 26201 304-472-1750

DATE PRINTED	TERMS OF SALE	SHIP VIA	F.O.B.	FREIGHT TERMS
10/25/2006				

BID OPENING DATE: **11/22/2006** BID OPENING TIME **01:30PM**

LINE	QUANTITY	UOP	CAT NO	ITEM NUMBER	UNIT PRICE	AMOUNT
<p>CERTIFICATION AND APPLICATION* IS HEREBY MADE FOR PREFERENCE IN ACCORDANCE WITH WEST VIRGINIA CODE, 5A-3-37 (DOES NOT APPLY TO CONSTRUCTION CONTRACTS).</p> <p>A. APPLICATION IS MADE FOR 2.5% PREFERENCE FOR THE REASON CHECKED:</p> <p>() BIDDER IS AN INDIVIDUAL RESIDENT VENDOR AND HAS RESIDED CONTINUOUSLY IN WEST VIRGINIA FOR FOUR (4) YEARS IMMEDIATELY PRECEDING THE DATE OF THIS CERTIFICATION; OR</p> <p>() BIDDER IS A PARTNERSHIP, ASSOCIATION OR CORPORATION RESIDENT VENDOR AND HAS MAINTAINED ITS HEAD-QUARTERS OR PRINCIPAL PLACE OF BUSINESS CONTINUOUSLY IN WEST VIRGINIA FOR FOUR (4) YEARS IMMEDIATELY PRECEDING THE DATE OF THIS CERTIFICATION; OR 80% OF THE OWNERSHIP INTEREST OF BIDDER IS HELD BY ANOTHER INDIVIDUAL, PARTNERSHIP, ASSOCIATION OR CORPORATION RESIDENT VENDOR WHO HAS MAINTAINED ITS HEADQUARTERS OR PRINCIPAL PLACE OF BUSINESS CONTINUOUSLY IN WEST VIRGINIA FOR FOUR (4) YEARS IMMEDIATELY PRECEDING THE DATE OF THIS CERTIFICATION; OR</p> <p>() BIDDER IS A CORPORATION NONRESIDENT VENDOR WHICH HAS AN AFFILIATE OR SUBSIDIARY WHICH EMPLOYS A MINIMUM OF ONE HUNDRED STATE RESIDENTS AND WHICH HAS MAINTAINED ITS HEADQUARTERS OR PRINCIPAL PLACE OF BUSINESS WITHIN WEST VIRGINIA CONTINUOUSLY FOR THE FOUR (4) YEARS IMMEDIATELY PRECEDING THE DATE OF THIS CERTIFICATION.</p> <p>B. APPLICATION IS MADE FOR 2.5% PREFERENCE FOR THE REASON CHECKED:</p> <p>() BIDDER IS A RESIDENT VENDOR WHO CERTIFIES THAT,</p>						

SEE REVERSE SIDE FOR TERMS AND CONDITIONS

SIGNATURE <i>Steven E. Johnson</i>	TELEPHONE 585-346-3040	DATE 11/14/06
TITLE <i>V. Jones</i>	FEIN 16-1441499	ADDRESS CHANGES TO BE NOTED ABOVE

WHEN RESPONDING TO RFQ, INSERT NAME AND ADDRESS IN SPACE ABOVE LABELED 'VENDOR'



State of West Virginia
 Department of Administration
 Purchasing Division
 2019 Washington Street East
 Post Office Box 50130
 Charleston, WV 25305-0130

Request for Quotation

RFQ NUMBER
707EC013

PAGE
5

ADDRESS CORRESPONDENCE TO ATTENTION OF
JOHN JOHNSTON
304-558-2402

VENDOR

*321105507 585-346-3040
 TENCO USA INC
 5700 SOUTH LIMA RD
 PO BOX 635
 LAKEVILLE NY 14480

SHIP TO

DIVISION OF HIGHWAYS
 EQUIPMENT DIVISION
 ROUTE 33
 BRUSHY FORK ROAD
 BUCKHANNON, WV
 26201 304-472-1750

DATE PRINTED	TERMS OF SALE	SHIP VIA	F.O.B.	FREIGHT TERMS
10/25/2006				

BID OPENING DATE: **11/22/2006** BID OPENING TIME **01:30PM**

LINE	QUANTITY	UOP	CAT NO	ITEM NUMBER	UNIT PRICE	AMOUNT
<p>DURING THE LIFE OF THE CONTRACT, ON AVERAGE AT LEAST 75% OF THE EMPLOYEES WORKING ON THE PROJECT BEING BID ARE RESIDENTS OF WEST VIRGINIA WHO HAVE RESIDED IN THE STATE CONTINUOUSLY FOR THE TWO YEARS IMMEDIATELY PRECEDING SUBMISSION OF THIS BID;</p> <p>OR</p> <p>() BIDDER IS A NONRESIDENT VENDOR EMPLOYING A MINIMUM OF ONE HUNDRED STATE RESIDENTS OR IS A NONRESIDENT VENDOR WITH AN AFFILIATE OR SUBSIDIARY WHICH MAINTAINS ITS HEADQUARTERS OR PRINCIPAL PLACE OF BUSINESS WITHIN WEST VIRGINIA EMPLOYING A MINIMUM OF ONE HUNDRED STATE RESIDENTS WHO CERTIFIES THAT, DURING THE LIFE OF THE CONTRACT, ON AVERAGE AT LEAST 75% OF THE EMPLOYEES OR BIDDERS' AFFILIATE'S OR SUBSIDIARY'S EMPLOYEES ARE RESIDENTS OF WEST VIRGINIA WHO HAVE RESIDED IN THE STATE CONTINUOUSLY FOR THE TWO YEARS IMMEDIATELY PRECEDING SUBMISSION OF THIS BID.</p> <p>BIDDER UNDERSTANDS IF THE SECRETARY OF TAX & REVENUE DETERMINES THAT A BIDDER RECEIVING PREFERENCE HAS FAILED TO CONTINUE TO MEET THE REQUIREMENTS FOR SUCH PREFERENCE, THE SECRETARY MAY ORDER THE DIRECTOR OF PURCHASING TO: (A) RESCIND THE CONTRACT OR PURCHASE ORDER ISSUED; OR (B) ASSESS A PENALTY AGAINST SUCH BIDDER IN AN AMOUNT NOT TO EXCEED 5% OF THE BID AMOUNT AND THAT SUCH PENALTY WILL BE PAID TO THE CONTRACTING AGENCY OR DEDUCTED FROM ANY UNPAID BALANCE ON THE CONTRACT OR PURCHASE ORDER.</p> <p>BY SUBMISSION OF THIS CERTIFICATE, BIDDER AGREES TO DISCLOSE ANY REASONABLY REQUESTED INFORMATION TO THE PURCHASING DIVISION AND AUTHORIZES THE DEPARTMENT OF TAX AND REVENUE TO DISCLOSE TO THE DIRECTOR OF PURCHASING APPROPRIATE INFORMATION VERIFYING THAT BIDDER HAS PAID THE REQUIRED BUSINESS TAXES, PROVIDED THAT SUCH INFORMATION DOES NOT CONTAIN THE AMOUNTS OF</p>						

SEE REVERSE SIDE FOR TERMS AND CONDITIONS

SIGNATURE <i>Stewart Easton</i>	TELEPHONE 585-346-3040	DATE 11/14/06
TITLE <i>V. Rep</i>	FEIN 16-1441499	ADDRESS CHANGES TO BE NOTED ABOVE

WHEN RESPONDING TO RFQ, INSERT NAME AND ADDRESS IN SPACE ABOVE LABELED 'VENDOR'



State of West Virginia
 Department of Administration
 Purchasing Division
 2019 Washington Street East
 Post Office Box 50130
 Charleston, WV 25305-0130

Request for Quotation

RFQ NUMBER
707EC013

PAGE
6

ADDRESS CORRESPONDENCE TO ATTENTION OF:
JOHN JOHNSTON
304-558-2402

VENDOR

*321105507 585-346-3040
 TENCO USA INC
 5700 SOUTH LIMA RD
 PO BOX 635
 LAKEVILLE NY 14480

SHIP TO

DIVISION OF HIGHWAYS
 EQUIPMENT DIVISION
 ROUTE 33
 BRUSHY FORK ROAD
 BUCKHANNON, WV
 26201 304-472-1750

DATE PRINTED 10/25/2006	TERMS OF SALE	SHIP VIA	F.O.B.	FREIGHT TERMS
-----------------------------------	---------------	----------	--------	---------------

BID OPENING DATE: **11/22/2006** BID OPENING TIME **01:30PM**

LINE	QUANTITY	UOP	CAT NO	ITEM NUMBER	UNIT PRICE	AMOUNT
<p>TAXES PAID NOR ANY OTHER INFORMATION DEEMED BY THE TAX COMMISSIONER TO BE CONFIDENTIAL.</p> <p>UNDER PENALTY OF LAW FOR FALSE SWEARING (WEST VIRGINIA CODE 61-5-3), BIDDER HEREBY CERTIFIES THAT THIS CERTIFICATE IS TRUE AND ACCURATE IN ALL RESPECTS; AND THAT IF A CONTRACT IS ISSUED TO BIDDER AND IF ANYTHING CONTAINED WITHIN THIS CERTIFICATE CHANGES DURING THE TERM OF THE CONTRACT, BIDDER WILL NOTIFY THE PURCHASING DIVISION IN WRITING IMMEDIATELY.</p> <p>BIDDER: <i>Tenco USA Inc</i></p> <p>DATE: <i>11/14/06</i></p> <p>SIGNED: <i>Steven Eaton</i></p> <p>TITLE: <i>Vice President</i></p> <p>* CHECK ANY COMBINATION OF PREFERENCE CONSIDERATION(S) IN EITHER "A" OR "B", OR BOTH "A" AND "B" WHICH YOU ARE ENTITLED TO RECEIVE. YOU MAY REQUEST UP TO THE MAXIMUM 5% PREFERENCE FOR BOTH "A" AND "B". (REV. 12/00)</p> <p>NOTICE</p> <p>A SIGNED BID MUST BE SUBMITTED TO:</p> <p>DEPARTMENT OF ADMINISTRATION PURCHASING DIVISION BUILDING 15</p>						

SEE REVERSE SIDE FOR TERMS AND CONDITIONS

SIGNATURE <i>Steven Eaton</i>	TELEPHONE <i>585-346-3040</i>	DATE <i>11/14/06</i>
TITLE <i>V. Pres</i>	FEIN <i>16-1441499</i>	ADDRESS CHANGES TO BE NOTED ABOVE

WHEN RESPONDING TO RFQ, INSERT NAME AND ADDRESS IN SPACE ABOVE LABELED 'VENDOR'



State of West Virginia
 Department of Administration
 Purchasing Division
 2019 Washington Street East
 Post Office Box 50130
 Charleston, WV 25305-0130

**Request for
 Quotation**

RFQ NUMBER
707EC013

PAGE
7

ADDRESS CORRESPONDENCE TO ATTENTION OF:
**JOHN JOHNSTON
 304-558-2402**

VENDOR

*321105507 585-346-3040
**TENCO USA INC
 5700 SOUTH LIMA RD
 PO BOX 635
 LAKEVILLE NY 14480**

SHIP TO

**DIVISION OF HIGHWAYS
 EQUIPMENT DIVISION
 ROUTE 33
 BRUSHY FORK ROAD
 BUCKHANNON, WV
 26201 304-472-1750**

DATE PRINTED	TERMS OF SALE	SHIP VIA	F.O.B.	FREIGHT TERMS
10/25/2006				

BID OPENING DATE: **11/22/2006** BID OPENING TIME **01:30PM**

LINE	QUANTITY	UOP	CAT NO	ITEM NUMBER	UNIT PRICE	AMOUNT
				2019 WASHINGTON STREET, EAST CHARLESTON, WV 25305-0130		
<p>THE BID SHOULD CONTAIN THIS INFORMATION ON THE FACE OF THE ENVELOPE OR THE BID MAY NOT BE CONSIDERED:</p> <p>SEALED BID</p> <p>BUYER: JJ-33</p> <p>RFQ. NO.: 707EC013</p> <p>BID OPENING DATE AND TIME</p> <p>PLEASE PROVIDE A FAX NUMBER IN CASE IT IS NECESSARY TO CONTACT YOU REGARDING YOUR BID:</p> <p>----- 585-346-2980 -----</p> <p>CONTACT PERSON (PLEASE PRINT CLEARLY):</p> <p>----- STEVEN EATON -----</p>						

SEE REVERSE SIDE FOR TERMS AND CONDITIONS

SIGNATURE *Steven Eaton* TELEPHONE **585-346-3040** DATE **11/14/06**

TITLE *V. Rep* FEIN **16-1441499** ADDRESS CHANGES TO BE NOTED ABOVE

WHEN RESPONDING TO RFQ, INSERT NAME AND ADDRESS IN SPACE ABOVE LABELLED 'VENDOR'



State of West Virginia
 Department of Administration
 Purchasing Division
 2019 Washington Street East
 Post Office Box 50130
 Charleston, WV 25305-0130

Request for Quotation

RFQ NUMBER
707EC013

PAGE
8

ADDRESS CORRESPONDENCE TO ATTENTION OF
JOHN JOHNSTON
304-558-2402

VENDOR

***321105507 585-346-3040**
TENCO USA INC
5700 SOUTH LIMA RD
PO BOX 635
LAKEVILLE NY 14480

SHIP TO

DIVISION OF HIGHWAYS
EQUIPMENT DIVISION
ROUTE 33
BRUSHY FORK ROAD
BUCKHANNON, WV
26201 304-472-1750

DATE PRINTED 10/25/2006	TERMS OF SALE	SHIP VIA	F.O.B.	FREIGHT TERMS
-----------------------------------	---------------	----------	--------	---------------

BID OPENING DATE: **11/22/2006** BID OPENING TIME **01:30PM**

LINE	QUANTITY	UOP	CAT NO.	ITEM NUMBER	UNIT PRICE	AMOUNT
***** THIS IS THE END OF RFQ 707EC013 ***** TOTAL:						<u>32,158.11</u>

SEE REVERSE SIDE FOR TERMS AND CONDITIONS

SIGNATURE <i>Steven Johnston</i>	TELEPHONE 585-346-3040	DATE 11/14/06
TITLE <i>V. Pres</i>	FEIN 16-1441499	ADDRESS CHANGES TO BE NOTED ABOVE

WHEN RESPONDING TO RFQ, INSERT NAME AND ADDRESS IN SPACE ABOVE LABELLED 'VENDOR'

WEST VIRGINIA DEPARTMENT OF TRANSPORTATION
DIVISION OF HIGHWAYS
EQUIPMENT DIVISION

PROCUREMENT SPECIFICATIONS
NO. 019-1-B

OPEN END CONTRACT
FRONT MOUNTED WING SNOWPLOW (LEFT, CENTER, RIGHT)

1.0 PURPOSE

It is the purpose of these specifications to describe a Front Mounted Wing Snowplow (Left, Center, Right) (hereinafter referred to as a "plow" or a "unit") to be purchased for use by the West Virginia Division of Highways (DOH) on an Open End Contract basis.

The plows are to be mounted on a West Virginia Division of Highways Mack Granite Tandem Axle Dump Truck (64,000 GVW) by the successful bidder as a complete working attachment. All parts not specifically mentioned, but necessary in order to provide a complete unit, shall be furnished and shall conform in strength, quality of material, and workmanship. The plow shall be new and heavy duty industrial production and shall include all of the latest improvements in design and all standard equipment and features to meet the listed bid specifications. Units not conforming to these specifications will be rejected.

2.0 BIDDING PROCEDURES

The current purchasing procedures regarding bidding as established by the Department of Administration, Purchasing Division, shall apply. Failure to submit the "Request for Quotation" forms, complete in its entirety and according to directions indicated, may subject the bidder to disqualification. Each bid submitted shall also be accompanied by a Bidder's Evaluation Report completed in detail. **FAILURE TO SUBMIT THE BIDDER'S EVALUATION REPORT, COMPLETE IN ITS ENTIRETY, MAY RESULT IN AUTOMATIC DISQUALIFICATION.**

3.0 SPECIFICATIONS

The specifications named herein, mandatory and non-mandatory, establish the acceptable level of quality only and are not intended to reflect a preference or favor any particular brand or vendor.

3.1 EXCEPTIONS TO NON-MANDATORY SPECIFICATIONS

Exception to a non-mandatory unit specification may be made by the bidder, providing the exception is not available from the manufacturer. Any such exception must be noted on the bidder's evaluation report and should be accompanied by supporting documentation/literature from the manufacturer. Any exception must be indicated on a

separate attachment to the bidder's evaluation report and labeled as "Exception to Specifications". The state reserves the right to determine whether the stated exception does or does not reduce the quality and performance of the unit. Failure to provide information for any exceptions may be grounds for rejection of the bid. The state reserves the right to waive minor irregularities in bids or specifications in accordance with §148-1-4(f) of the WV Legislative Rules and Regulations.

3.2 MANDATORY SPECIFICATIONS

All specifications preceded by "shall and/or must" or are stated as a "minimum and/or maximum" are mandatory. Any bid failing to meet any mandatory item shall be immediately disqualified. Failure to respond in the appropriate evaluation section may also be grounds for immediate disqualification at the discretion of the State.

A mandatory pre-bid conference is scheduled for this equipment purchase as stated in the RFQ. Vendors having products with variations or exceptions in specified mandatory items are expected to address any such variations or exceptions during the pre-bid conference. The State shall review and consider any such variation or exception, and may at its sole discretion, issue an addendum to change mandatory specifications deemed to be in the State's best interest. Bids from any vendor failing to attend the mandatory pre-bid shall be disqualified. Bids containing any variation or exception to a mandatory specification that was not addressed during the pre-bid conference and accepted by the issuance of an Addendum shall be disqualified.

4.0 REPRESENTATIVE UNIT FOR TEST

The successful vendor must (if specified) provide DOH one (1) completed representative unit to be observed and evaluated on the first order only to insure compliance with specification. If requested, the time period for testing and evaluation shall be seven (7) working days following receipt of the unit. DOH will incur no obligation for deterioration of surfaces, finishes, seals, and mechanical or electrical parts on the unit resulting from operation and testing within the limits of these specifications; nor will DOH incur obligation for damage to the unit resulting from failure to meet specifications when due care and attention is given by DOH and testing is done within the limits of these specifications. Failure of the pilot unit to satisfactorily meet specifications as bid shall be cause for cancellation of the purchase order, and return of the delivered unit along with all associated equipment to the vendor at the vendor' expense.

4.1 CONDITION OF UNIT(S) UPON DELIVERY

All units must arrive at the prescribed delivery point having been completely preserviced with oil, lubricants, and coolant. All prescribed precautions pertaining to first operations and break-in of the unit are to be posted conspicuously on the unit for ready observance by the operator.

4.2 DELIVERY

Trucks are to be picked up at Division of Highways facilities and plows mounted at successful bidders facilities. After installation of plows etc., trucks to be delivered to the respective West Virginia Division of Highways facilities by successful bidder.

The vendor is responsible for guaranteeing delivery of the completed units within the time specified and agreed to by the State. Delivery is preferred within 60 days. The vendor is responsible for establishing and coordinating delivery terms with allied manufacturers or suppliers. Delivery terms shall be stated in the bid and the State reserves the right to accept or negotiate such terms. Failure to reach an agreement may result in rejection of the bid. The successful bidder shall provide their manufacturer's confirmation of the order to the WVDOH contact person within seven (7) working days after receiving the approved purchase order.

A completed pilot model for inspection must be provided within 30 calendar days after the date of the purchase agreement by the successful vendor.

Delivery is an integral part of this specification and failure to comply will be cause to initiate a D.O.T. Administrative Form WV-82, Vendor Performance Form. The WV-82 Form will provide a means of officially notifying the Purchasing Division and the vendor of unsatisfactory performance; such as late deliveries, poor service, inadequate parts supplies, etc.

The decision to initiate subject Form will be at the sole discretion of the D.O.H. Commissioner's established Equipment Review Board.

Issuance of the WV-82 Vendor Complaint Form on unsatisfactory delivery against any vendor will be cause to refuse to consider similar items from those vendors on future Request For Quotations.

(NOTE: Delivery time could be altered due to labor strikes, severe inclement weather conditions, etc.)

5.0 AWARD CRITERIA

5.1 DOH will recommend the award in accordance with the RFQ evaluation criteria described in the requisition. The award shall be made to the lowest unit cost vendor that meets or exceeds the specifications.

Prices for the units shall be in quantities of 1-5, 6-10, 11-20, 21 and over. However, for evaluation purposes, we will use quantities 1-5. DOH reserves the right to place multiple orders in any quantity.

6.0 SPECIFICATIONS AND GUIDELINES – GENERAL

6.1 IDENTIFICATION OF THE UNIT BEING PROPOSED

The bidder must identify the unit by manufacturer, model, series, and year of manufacture, in the bid to enable identification by DOH in the manufacturer's specifications of the proposed unit. The bidder will submit complete descriptive literature of the proposed unit, to establish that the bid is the manufacturer's most current model, including latest engineering improvements, which have been, or will imminently be, regularly advertised and sold on the open market. The unit specified herein and offered to be manufactured after January 1, 2006 and be clearly identified and marked with date of manufacture.

6.2 OPERATING AND SERVICE MANUALS AND PARTS LISTS

An operator's manual must be included with each unit upon delivery. A "line sheet" (if applicable) and Equipment Preventative Maintenance Questionnaire (as shown in X6.2 of the Bidder's Evaluation Report) must be with pilot unit upon delivery. In addition, there must be 12 service, shop, or maintenance manuals; ten (10) to be distributed to the Districts and two (2) for the Equipment Division. Also, there must be 14 parts manuals; ten (10) to be distributed to the Districts and four (4) for Equipment Division use. CD ROM is preferred in lieu of parts manuals.

* NOTE: MANUALS SHALL BE DELIVERED UPON COMPLETION OF DELIVERY OF TOTAL UNITS. FAILURE TO DO SO WILL DELAY PAYMENT.

6.3 TRAINING:

Manufacturers and/or dealers will be required to stage a thorough seminar on the subjects of Preventative Maintenance, Operator and Mechanic Training. In order to keep the operators and mechanics updated, the successful vendor shall conduct training with this purchase order. Training is preferred within 2 working days after delivery of the pilot unit on the individual purchase order.

Manufacturers and/or dealers shall be required to furnish the Training Academy with one (1) Operator's Manual.

The seminar to be held at the W. Va. Division of Highways, Equipment Division, Buckhannon, West Virginia.

6.4 PREVENTIVE MAINTENANCE AND OPERATOR PROCEDURES:

Manufacturers and/or dealers will be required to submit to the Equipment Division, in addition to the operating and service manuals, booklets and pamphlets explaining the

Preventive Maintenance and Operator Procedures to be used by the operators of this equipment, and must include such things as daily prestart inspection procedure, service schedule, and routine maintenance required, safety precautions, etc.

The successful vendor shall furnish all training aids; i.e., videos, projectors, etc. required in conducting the training.

6.5 WARRANTY AND SERVICE POLICY

The Manufacturers warranty or service policy is to apply to the unit. Such warranty or service policy is to be recognized at any authorized unit dealer, representing manufacturer of proposed unit throughout the State of West Virginia. The applicable warranty or service policy will not be contingent upon obtaining routine service, lubrication, and servicing of the unit from factory authorized agencies. It will be the responsibility of the bidder to have available labor to repair or replace any defective replacement parts, components and materials, and to have available those replacement parts, components, and/or materials found to be defective during the terms of the warranty period. The bidder should state the labor rates, locations where parts will be stocked, availability of parts, and discounts offered for parts, when terms of the warranty offer a pro-rated cost for parts and labor. In addition, the successful bidder should offer field work to repair or replace defective parts, components, and materials found to be defective during the terms of the warranty and should provide mechanic's travel rates, mileage charges, field mechanic rates, and any surcharge for miscellaneous items, if applicable, for field work during the warranty period. Submit to Division of Highways any technical or engineering improvements during the term of the warranty. The unit must be accompanied upon delivery by the unit's manufacturer's executed warranty or service policy.

A minimum two (2) year basic bumper to bumper warranty shall apply to the unit.

THE "WARRANTY AND SERVICE POLICY QUESTIONNAIRE" ATTACHED IN THE BIDDER'S EVALUATION REPORT MUST BE COMPLETED IN ITS ENTIRETY BY THE SUCCESSFUL BIDDER OR MANUFACTURER PRIOR TO DELIVERY OF THE PILOT MODEL. (SEE SECTION X6.5 OF BIDDER'S EVALUATION REPORT).

6.6 EVALUATION COMMITTEE REQUIREMENTS

Detailed component specifications, product literature, component models, required for specification compliance determination by the Evaluation Committee should be provided with each bid. Any information supplied that is contrary to/or conflicting with the specifications and/or attached Bidders Evaluation Report may be sufficient cause for rejection of bid.

6.7 UNSPECIFIED ACCESSORIES & FEATURES

All parts, equipment, accessories, material, design and performance characteristics not specified herein, but which are necessary to provide a complete unit, must be furnished with each unit and required to conform to strength, quality of material, and quality of workmanship to those which are advertised and provided to the market in general by the unit industry.

All parts and accessories advertised and regularly supplied as standard shall be included, except those which would represent duplication of these specified, and except those which, by specification, are not to be furnished. All standard safety features, required by Federal and State Law, shall be included.

7.0 SPECIFICATIONS OF THE QUOTED UNIT ARE AS FOLLOWS:

The hydraulic wing snowplow is to be designed for mounting on a tandem dump truck.

The hydraulic power for lifting etc. will be supplied by the truck central hydraulic system. However, the vendor shall supply the hose and fittings to connect plow systems to valving, located under the front bumper.

7.1 Front Hitch:

- 7.1.1 Front hitch designed as a universal heavy duty type unit to carry plows of weight specified when mounted on 64,000 GVW truck minimum
- 7.1.2 Top of hitch to be mounted to the frame rail of the truck, using minimum of seven (7) 1 inch Grade 8 bolts on each side.
- 7.1.3 Middle of front hitch shall extend out both sides to attach the front wing posts.
- 7.1.4 Front wing mast – left and right – horizontal support grinder to be 7 in./(17.8 CH) cross channel or 7 in. (17.8 CH) ship and car channel at 22.7 lb/ft or tubing 7 in./(17.8 CH) x 4 in (10 CH) x .3750 in/.9525 cm.
- 7.1.5 Front wing mast – left and right – wing post cross tube shall be mounted to truck frame members

7.2 Front Wing Mast – Left and Right:

- 7.2.1 The wing mast shall not block OEM headlights
- 7.2.2 Wing post I-beam minimum seven (7) inch (17.8 CH) x 15.3 lb/ft.
- 7.2.3 Wing post side lift shall have a minimum lift from ground to bottom of plow edge for travel of 10 inches /(25 cm)

- 7.2.4 Front wing post cylinder shall be double acting ram-direct (no cables) with float and 500 PSI relief on the down side
- 7.2.5 Front wing post and support strut-girder arrangement shall be attached in such a way that the load is properly distributed to both chassis frame rails, without the use of bracing tubes
- 7.2.6 Support struts shall be no less than 1.250 in/(3.175 cm) diameter schedule 80ASTMA106 Grade A or B seamless pipe brace (minimum of two (2)) or equal.
- 7.2.7 Hinge assembly shall be detachable from the slider assembly of the wing mast. (Bolts minimum Grade 8, .6250 in/1.588 CH-N.C.)
- 7.2.8 Wing shall have double acting cylinder which provides full power up
- 7.2.9 Wing plow shall have a mechanical alarm system to alert the operator of the position of the plow
 - 7.2.9.1 Alarm system must be visible from driver's seat (Ref: EQN-60A)
- 7.2.10 Front wing mast shall be vertical lift type, hydraulically controlled by a direct lift double acting cylinder.
- 7.2.11 The front cylinder shall have a quick connect coupler/s.
- 7.2.12 A minimum 3 in./(7.6 CH x 15 in/(38 cm) cylinder from rear "A" frame to mold board to raise the rear of the wing and fold the wing close to the truck for transport.
- 7.3 Rear Wing Tower – Left and Right:
 - 7.3.1 Rear wing truck attachment shall be no less than 8 inch I-beam of 20 lb/ft. or 8 inch 20 lb/ft structural channel
 - 7.3.1.1 I-beam shall be supported by manufacturers recommended that will provide maximum longevity of the plow
 - 7.3.2 Rear wing to have two (2) point attachment for the bottom push arms and for the cylinder to lift the wing into the carry position.
 - 7.3.3 Attachment to the truck shall be no less than 1 inch x 5 inch plate steel across the top of the truck frame as close to the cab as possible
 - 7.3.3.1 This plate shall have gussets at the high stress points

- 7.3.3.2 Welded to this point shall be no less than 4 inch x 3 inch x 3/8 inch angle which shall run parallel to the truck frame and bolt tight to the same.
- 7.3.3.3 This angle to the rear post shall be braced
- 7.4 Wing Stand Off Arms: Left and Right:
 - 7.4.1 Wing push arms shall be of the heavy duty type
 - 7.4.2 Bottom push arms shall be constructed of manufacturer's heaviest duty material.
 - 7.4.2.1 To adjust push arm length, a cylinder must be used to slide the inner tube through the outer tube
 - 7.4.2.2 A cylinder must be used to attach to the two (2) point attachment on the truck to the bottom push arm to lift and tuck the wing in as tight to the truck as possible.
 - 7.4.2.3 It is preferred that cylinders be nitrated for superior wear and corrosion resistant
- 7.5 Trip Wing Hinge – Left and Right:
 - 7.5.1 The wing shall be attached to the front wing post with a trip hinge
 - 7.5.2 The hinge shall be designed to allow the wing to trip and reset automatically when hitting an obstruction
 - 7.5.3 The reset shall be with a rubber compression and not with coil spring
 - 7.5.4 The hinge should have two (2) offset hinges to lift the wing as it trips.
- 7.6 Side Wing – Left and Right Side:
 - 7.6.1 Side wing shall be designed for the right side of the truck and shall be heavy duty
 - 7.6.2 Side wing over all length approximately 132 inches with 120 inch x 8 1/2 inch cutting edge minimum
 - 7.6.3 Nose height approximately 32 inches and discharge height approximately 39 1/2 inches.
 - 7.6.4 Cutting edge backer shall be a minimum 4 inches x 4 inches x 5/8 inches punched to accept 8 inch or 3inch – 3 inch – 12 inch punch cutting edge
 - 7.6.5 Backer shall be manufacturer's heaviest design

- 7.6.6 The leader shall be a minimum of 1 inch plate steel and shall have a means of accepting a 1 1/4 inch wing bolt
- 7.6.7 Wing skin must be no less than 10 gauge steel
- 7.6.8 Steel on wing shall be sand blasted before primer and back of wing shall be painted orange (Sico #517553 or equal).
- 7.7 Reversible Plow:
- 7.7.1 Plow shall have a clearing path of 12 feet in the bulldozer position and shall clear 9 feet 8 inches at 30 degrees.
- 7.7.2 Overall height of plow shall be maximum 42 inches
- 7.7.3 Top of mold board shall be manufacturer's heaviest duty design
- 7.7.3.1 A minimum of seven (7) 3/8 inch ribs shall be welded to the above mentioned manufacturers heaviest duty design
- 7.7.3.2 Bottom of ribs shall be welded to a 4 inch x 6 inch x 5/8 inch (minimum) boxed hinge and spring support
- 7.7.4 Hinges shall be the support for the trip edge section.
- 7.7.5 Cutting edge backer shall be a minimum of 4 inch x 4 inch x 3/4 inch angle supported by a minimum of six (6) plate hinges flame cut of a minimum of 5/8 inch steel
- 7.7.6 Trip section shall be one (1) piece trip and shall become three (3) section by removing two (2) 1 inch section bolts allowing the cutting edge to be three (3) section trip
- 7.7.7 Trip section shall be reset after hitting an obstruction by torsion or by coil springs mounted vertical behind the trip mechanism
- 7.7.8 If coil springs are used, then they shall be wound of 7/8 inch wire (minimum) and have a minimum of eight (8) coils
- 7.7.9 Should be a minimum of two (2) spring retainer holes to allow for spring tension adjustment
- 7.7.10 Replaceable cutting edge shall be 1/2 inch x 8 inches mounted by 5/8 inch bolts on 8 inch center

- 7.7.11 Backer iron for cutting edge shall be punched to receive both 8 inch AHD 3-3-12 replacement edges.
- 7.7.12 Two (2) mold board shoes and two (2) curb shoes; one (1) left side and one (1) right side to be provided
 - 7.7.12.1 Curb shoes to be minimum of 1 1/2 foot shaft with 65K Rockwell hardness
- 7.7.13 Mold board skin shall be no less than 10 gauge steel and shall be welded to the top, ribs, and bottom supports
- 7.7.14 A-frame to be minimum of 4 inch x 4 inch x 3/8 inch tubular steel and pin to the main frame support tube
- 7.7.15 Main frame support tube to be no less than 4 inch x 4 inch x 3/8 inch tubing
- 7.7.16 A-frame reversing table shall be flame cut 1/2 inch plate steel and shall be a minimum of 9 inches wide.
- 7.7.17 The evener plate shall have stops to restrict the plow from listing more than 25 degrees
- 7.7.18 Plow to be attached to the truck with two (2) ears of 1 inch steel (minimum)
 - 7.7.18.1 Ears to be on 31 inch centers
- 7.7.19 Reversing to be achieved with two (2) industrial type cylinders with a 1 1/2 inch shaft, 3 inch barrel and an 18 inch stroke
 - 7.7.19.1 Cylinders must be protected with built in cushion valve
- 7.7.20 Push frame shall pin to the mold board providing the capability of adjusting the cutting edge angle to the road after the plow has been attached to the truck
- 7.7.21 The lifting device shall be a pulley and cable design to allow the plow to be raised with a minimum of lift.
- 7.7.22 All steel shall be sand blasted and painted
- 7.8 Control Valves:
 - 7.8.1 Control valves must be commercial or equal
 - 7.8.2 There shall be six (6) section right front wing, right rear wing, right telescopic, left front wing, left rear wing and left telescopic.

- 7.8.3 The cab controls push pull cables to be Wescon Model #08-5700-08 or equal
- 7.8.4 Controls for dump body shall have built in lock out to prevent accidental actuation.
- 7.8.5 Controls to be mounted as directed by West Virginia of Highways Equipment Division.
- 7.8.6 Valves shall have a built in relief
- 7.9 Hoses and Fittings:
 - 7.9.1 All hydraulic hoses and fittings shall be JIC with o-ring boss thread adaptors.
 - 7.9.2 Hoses and fittings to be placed so as not to be damaged from rubbing or heat
 - 7.9.3 As needed, hoses shall be wrapped with loom for protection.
- 7.10 Installation:
 - 7.10.1 Equipment shall be mounted neatly on truck furnished by Division of Highways
 - 7.10.2 Installation to include all hoses, fittings, and other appurtenance required to have a complete and ready unit.
 - 7.10.3 Shall be plow lights top of plow frame mounted with the system
 - 7.10.4 All steel shall be sandblasted before primer and paint is applied.
 - 7.10.5 Vendor must have insurance to cover trucks while at mounting facility and during transport.
- 7.11 Unit shall include all other features considered as standard equipment but not specifically addressed above.
- 7.12 Vendor must certify that snowplow offered will comply with the Occupational Safety and Health Act of 1970 and subsequent amendments.
- 7.13 Advertising: Manufacturer shall attach a metal plate on the reverse side of the moldboard stating manufacturer, series or model number, size and type of blade (approximately 6 inch to 8 inch square). Date of manufacturer shall also be stamped on plate or moldboard. No large decals or painted advertisement is permitted.
- 7.14 All loose hardware to be in a separate container for each plow and shipped with each plow.

NOTE: Vendor should type Bidder's Evaluation Report

WEST VIRGINIA DEPARTMENT OF TRANSPORTATION
DIVISION OF HIGHWAYS
EQUIPMENT DIVISION

BIDDER'S EVALUATION REPORT

PROCUREMENT SPECIFICATIONS
NO. 019-1-B

OPEN END CONTRACT
FRONT MOUNTED WING SNOWPLOW (LEFT, CENTER, RIGHT)

NOTE TO BIDDER: Procurement Specification No. 019-1-B, Paragraph 2.0 recommends the completion and submittal of this Report with your bid. Purpose of this Report is to enable the West Virginia Division of Highways Evaluation Committee to make full and fair evaluation of the bid.

FAILURE TO SUBMIT THIS REPORT, COMPLETE IN ITS ENTIRETY, MAY SUBJECT THE BIDDER TO DISQUALIFICATION.

Reference Requisition No.: 207EC013

Bidder's Name: TENCO U.S.A. INC.

Address: 5700 S. LIMARO, LAKEVILLE, N.Y. 14480-0635

Telephone Number: 585-346-3040

Years Bidder has been registered to do business with the State of West Virginia: 1 YRS.

Years Company has been an authorized dealer for proposed unit: 14 YRS.

X4.2 DELIVERY:

X4.2.1 Delivery date of completed representative unit: 30 Calendar Days After Date of Purchase Agreement

X4.2.2 Delivery date of balance of completed units: 60 Calendar Days After Date of Purchase Agreement

X5.0 AWARD CRITERIA;

X5.1	Prices for unit including installation in quantities of	1-5	<u>\$ 32,158.00</u>	per unit
		6-10	<u> </u>	per unit
		11-20	<u> </u>	per unit
		21 and over	<u> </u>	per unit

X6.0 SPECIFICATIONS - GENERAL

X6.1 Manufacturer, model, series, and date of manufacture of proposed unit:

TENCO Machinery, TC-P-12-5-42-E2-11A2, TEW-1014-58-N-R+L
 Is descriptive literature, fully describing proposed unit attached to your bid? YES NO

If not, why? _____

6.2 Will the required number of service manuals, and complete parts list be delivered to the Equipment Division at Buckhannon upon completion of delivery of total units? YES NO

Will the required Equipment Preventive Maintenance Form (Section X6.2 of Bidders Evaluation Report) be provided upon inspection of the pilot unit? YES NO

X6.2
2-10-00

EQUIPMENT PREVENTATIVE MAINTENANCE QUESTIONNAIRE

THIS FORM MUST BE COMPLETED IN ITS ENTIRETY BY SUCCESSFUL BIDDER OR MANUFACTURER-S TECHNICAL REPRESENTATIVE PRIOR TO DELIVERY OF PILOT MODEL TO THE WVDOH.

DESCRIPTION: _____ MAKE: _____

MODEL: _____ YEAR: _____ PURCHASE AMOUNT: _____

ENGINE: MAKE: _____ MODEL: _____ FUEL TYPE: _____

HORSEPOWER: _____ CYLINDER: _____ ENGINE SERIAL: _____

COOLING SYSTEM CAPACITY: _____

BELTS: DESCRIPTION: _____ PART NUMBERS: _____

GVW: _____ AXLE CAPACITY: FRONT: _____ REAR: _____

TIRES: FRONT MAKE & SIZE: _____

REAR MAKE & SIZE: _____

DIMENSIONS OF UNIT: LENGTH: _____ WIDTH: _____ LENGTH: _____

VENDOR CONTACT PERSON: _____ PHONE: _____

PARTS:

BATTERY MAKE: _____ MODEL: _____ CCA: _____

TOP OR SIDE POST: _____ DIMENSIONS: LENGTH _____ WIDTH _____ HEIGHT _____

SPARK PLUGS OR FUEL INJECTORS MAKE: _____ PART # _____

FUEL PUMP OR INJECTION PUMP MAKE: _____ MODEL: _____

ALTERNATOR MAKE: _____ PART #: _____

STARTER MAKE: _____ PART #: _____

TURBO CHARGER MAKE: _____ PART #: _____

TRANS. MAKE: _____ MODEL: _____ AUTO/MANUAL: _____

HYDRAULIC PUMP MAKE: _____ MODEL: _____

FILTERS	MAKE	PART NO.	LUBRICANT	MANUFACTURER TYPE
---------	------	----------	-----------	-------------------

OIL	_____	ENGINE	_____
-----	-------	--------	-------

AIR INNER	_____	TRANSMISSION	_____
-----------	-------	--------------	-------

AIR OUTER	_____	POWER STEERING	_____
-----------	-------	----------------	-------

FUEL PRIMARY	_____	HYDRAULIC	_____
--------------	-------	-----------	-------

FUEL SECONDARY	_____	DIFFERENTIALS	_____
----------------	-------	---------------	-------

COOLANT	_____	BRAKE FLUID	_____
---------	-------	-------------	-------

HYDRAULIC	_____	COOLANT	_____
-----------	-------	---------	-------

OTHER	_____	OTHER	_____
-------	-------	-------	-------

X6.3 TRAINING:

Will training seminar be conducted on Preventive Maintenance, Operator and Mechanic Training
 YES NO

Will you conduct training with each purchase order against this open end contract?
 YES NO

Will training be conducted within 2 working days from the delivery of the pilot unit on the individual purchase order?
 YES NO

If NO, explain time frame _____

Will an Operator's Manual be furnished to the Training Academy? YES NO

X6.4 If you are the successful vendor, will you furnish all training aids, i.e., videos, projectors, required in conducting the training?
 YES NO

X6.4.1 Will all manuals, booklets, etc. explaining preventive maintenance, operator procedures, and service schedule be delivered with each unit?
 YES NO
 If NO, explain _____

X6.5 WARRANTY AND SERVICE POLICY

Will the warranty and service you provide comply with all areas as stated in Section 6.5 of specifications
 YES NO

Is warranty literature attached? YES NO EXTENDED

Does the unit have a minimum two (2) year bumper to bumper basic warranty? YES NO

Describe: MATERIAL & WORKMANSHIP

X6.5 WARRANTY AND SERVICE POLICY QUESTIONNAIRE

THIS FORM MUST BE COMPLETED IN ITS ENTIRETY BY THE SUCCESSFUL BIDDER OR MANUFACTURERS TECHNICAL REPRESENTATIVE PRIOR TO DELIVERY OF PILOT MODEL TO THE WVDOH (If additional lines are needed, make copies of form.)

1. Define the terms of the standard warranty. If not offered, so state. (Attach copy)

2. Define warranty service to be performed at DOH facilities and warranty service to be performed at manufacturer's representative facility. List name and location of manufacturer's representative.

3. List locations for parts inventories that are within the State of West Virginia. Also, list availability levels, if known.

4. During the term of warranty, list the guarantee discount to manufacturer's published list price for parts that bidder will sell the parts to owner.

- | | | |
|----|---------------|--|
| A. | Terms: Net 30 | Manufacturer's published list price less: _____ % discount |
| B. | Terms: Net 60 | Manufacturer's published list price less: _____ % discount |
| C. | Terms: Net 90 | Manufacturer's published list price less: _____ % discount |

5. During the term of warranty, will all manufacturers or engineering improvements be submitted to Division of Highways? _____ YES _____ NO

6. During the term of warranty, list the guaranteed rates charged for repair to the unit.

- | | | |
|----|---|--|
| A. | Shop Rate | \$ _____ per mechanic hour |
| B. | Travel Time Charge
(Specify if one-way) | \$ _____ per mechanic hour
_____ ; port to port _____ |
| C. | Mileage Charge
(Specify if one-way) | \$ _____ per vehicle mile
_____ ; port to port _____ |
| D. | Field Mechanic Rate | \$ _____ per mechanic hour |
| E. | Specify period of time that prices are in effect: _____ | |
| F. | Surcharge for miscellaneous items: _____ % | |

X6.6 EVALUATION COMMITTEE REQUIREMENTS

Is all component specifications, product literature, component models provided for Evaluation Committee bid determination? YES NO

X6.7 Will all parts, equipment, accessories, material, design and performance characteristics not specified herein, but which are necessary to provide a complete unit, be furnished with the unit and conform in strength, quality of material, and quality of workmanship to those which are advertised and provided to the market in general by the unit industry? YES NO

X6.7.1 Are all parts and accessories adequate and regularly supplied as standard to be included except those which may be duplications of specifications herein, and except these by specification are not to be furnished? YES NO

X6.7.2 Are all standard safety features that are required by Federal and State statutes of law included? YES NO

X7.0 SPECIFICATIONS OF THE QUOTED UNIT

The bidder should complete the following schedule in order for the Division to compare the actual bid unit to the specifications. Should the bidder except a requirement, then such exception may be only on the basis that such feature is not offered by the manufacturer. The Division will have the sole discretion as to whether the bidder's substitution meets the requirements of the specifications.

Will hydraulic wing snowplow be designed for mounting on a tandem dump truck YES NO

Is the hydraulic power for lifting etc. supplied by the truck central hydraulic system YES NO

Will you supply the hose and fittings to connect plow systems to valving, located under the front bumper YES NO

Manufacturer: PARKER Model: R2

X7.1 Front Hitch:

X7.1.1 Is the front hitch designed as a universal heavy duty type unit to carry plows of weight specified when mounted on 64,000 GVW truck minimum YES NO

X7.1.2 Is top of hitch mounted to the frame rail of the truck using 7 1 inch Grade 8 bolts on each side YES NO

X7.1.3 Middle of front hitch extends out both sides to attach the front wing posts YES NO

X7.1.4 Is front wing mast – left and right – horizontal support grinder 7 inch cross channel or 7 inch ship and car channel at 22.7 lb ft. or tubing 7 inch x 4 inch x .3750 inch YES NO

X7.1.5 Is front mast – left and right – wing post cross tube mounted to truck frame members YES NO

6 Through Plow Hitch

X7.2 Front Wing Mast – Left and Right:

- X7.2.1 Does wing mast block OEM headlights YES NO
- X7.2.2 Wing post I-beam : 17.8 x 15.3 lb/ft.
- X7.2.3 Wing post side lift: 18"
with lift from ground to bottom of plow edge for travel of 18 inches
- X7.2.4 Is front wing post cylinder double acting ram-direct (no cables) with float and 500 PSI relief on the down side YES NO
- X7.2.5 Is front wing post and support strut-girder arrangement attached in such a way that the load is properly distributed to both chassis frame rails, without the use of bracing tubes YES NO
- X7.2.6 Support struts: _____ in. diameter schedule _____
Grade A or B seamless pipe brace (minimum of two (2)) YES NO SEE 7.2.5
- X7.2.7 Is hinge assembly detachable from the slider assembly of the wing mast YES NO
Bolts – Grade 8 1/2" in / 1.56 CH-N.C.
- X7.2.8 Does wing have double acting cylinder which provides full power up YES NO
- X7.2.9 Does wing plow have a mechanical alarm system to alert the operator of the position of the plow YES NO
- X7.2.9.1 Is alarm system visible from driver's seat YES NO
Manufacturer/model SAFETY SOURCE WF-24
- X7.2.10 Is front wing mast vertical lift type, hydraulically controlled by a direct lift double acting cylinder YES NO
- X7.2.11 Does the front cylinder have a quick connect coupler/s YES NO
- X7.2.12 Size of cylinder from rear "A" frame to mold board to raise the rear of the wing and fold the wing close to the truck for transport: 3" x 15"
- X7.3 Rear Wing Tower - Left and Right:
- X7.3.1 Rear wing truck attachment I-beam: 8 inch of 20 lb/ft or - inch - lb/ft structural channel
- X7.3.1.1 I-beam supported by MANUFACTURE & ALUMINUM that will provide maximum longevity of plow
- X7.3.2 Does rear wing have two (2) point attachment for the bottom push arms and for the tilt cylinder to lift the wing into the carry position YES NO

- X7.3.3 Attachment to the truck 1 inch x 5" inch plate steel across the top of the truck frame as close to the cab as possible X YES ___ NO
- X7.3.3.1 Does this plate have gussets at the high stress points X YES ___ NO
- X7.3.3.2 Angle welded to this point which runs parallel to the truck frame and bolt tight to same: 5/8 inch x 2" inch x ___ inch
- X7.3.3.3 Is this angle to the rear post braced X YES ___ NO
- X7.4. Wing Stand Off Arms – Left and Right:
- X7.4.1 Are wing push arms of the heavy duty type X YES ___ NO
- X7.4.2 Bottom push arms constructed of manufacturer's heaviest duty material X YES ___ NO
- X7.4.2.1 To adjust push arm length, will a cylinder be used to slide the inner tube through the outer tube X YES ___ NO
- X7.4.2.2 Will a cylinder be used that attaches to the two (2) point attachment on the truck and to the bottom push arm to lift and tuck the wing in as tight to the truck as possible X YES ___ NO
- X7.4.2.3 Are cylinders nitrated for superior wear and corrosion resistant X YES ___ NO
- X7.5 Trip Wing Hinge – Left and Right:
- X7.5.1 Is the wing attached to the front wing post with a trip hinge X YES ___ NO
- X7.5.2 Is the hinge designed to allow the wing to trip and reset automatically when hitting an obstruction X YES ___ NO
- X7.5.3 Is reset with a rubber compression and not with coil spring YES X NO
RUBBER COMPRESSION IS SUPERIOR SEE ENCLOSED
- X7.5.4 Does the hinge have two (2) offset hinges to lift the wing as it trips X YES ___ NO
- X7.6 Side Wing – Left and Right Side:
- X7.6.1 Is the side wing designed for the right side of the truck and heavy duty X YES ___ NO
- X7.6.2 Side wing overall length 132" inches with 120" inch x 8 1/2" inch cutting edge
- X7.6.3 Nose height 32" inches and discharge height 39 1/2" inches
- X7.6.4 Cutting edge backer 4" inches x 6" inches x 5/8" inches punched to accept 8" OR 8.3-12 punch cutting edge
- X7.6.5 Is backer manufacturer's heaviest design X YES ___ NO

- X7.6.6 Does the leader have at least 1 inch plate steel and has means to accept a 1 1/4 inch wing bolt
 YES NO
- X7.6.7 Wing skin is 10 gauge steel
- X7.6.8 Is steel on wing sand blasted before primer and back of wing painted orange YES NO
- Paint manufacturer & number: Seco 517-537 Tenax #991280011
- X7.7 Reversible Plow:
- X7.7.1 Does path have a clearing path of 12 feet in the bulldozer position and clear 9 feet 8 inches at 30 degrees
 YES NO
- X7.7.2 Overall height of plow 42" inches
- X7.7.3 Is top of moldboard manufacturer's heaviest duty design
 YES NO
- X7.7.3.1 Number and size of ribs welded to the above mentioned manufacturer's heaviest duty Design: 2 and size 3/8
- X7.7.3.2 Bottom of ribs welded to a 4 inch x 6 inch x 5/8 inch boxed hinge and spring support
 YES NO
- X7.7.4 Are the hinges the support for the trip edge section
 YES NO
- X7.7.5 Cutting edge backer inch x inch x 3/4 inch angle supported by 6 plate hinges flame cut of 5/8 inch steel
- X7.7.6 Does trip section have one (1) piece trip and become three (3) section by removing two (2) 1 inch section bolts allowing the cutting edge to be three (3) section trip YES NO
- X7.7.7 Is trip section reset after hitting an obstruction by torsion or coil springs mounted vertical behind the trip mechanism
 YES NO
- X7.7.8 Coil spring wound of 3/8 inch wire and has 8 coils
- X7.7.9 Number of spring retainer holes to allow for spring tension adjustment: 2
- X7.7.10 Is replaceable cutting edge 1/2 inch x 8 inches mounted by 5/8 inch bolts on 8 inch center
 YES NO
- X7.7.11 Is backer iron for cutting edge punched to receive both 8 inch AHD 3-3-12 replacement edges
 YES NO
- X7.7.12 Number of mold board shoes: 2 Number of curb shoes: 2
Is one (1) left side and one (1) right side YES NO
- X7.7.12.1 Curb shoes 1 1/2 foot shaft with 65K Rockwell hardness YES NO

- X7.7.13 Mold board skin 10 gauge steel and welded to the top, ribs, and bottom supports YES NO
- X7.7.14 Is A-frame 4 inch x 4 inch x 3/8 inch tubular steel and pin to the main frame support tube YES NO
- X7.7.15 Main frame support X inch x X inch x 3/8 inch tubing
- X7.7.16 Is A-frame reversing table cut flame cut 1/2 inch plate steel YES NO
Width: 9 inches
- X7.7.17 Does the evener plate have stops to restrict the plow from listing more than 25 degrees YES NO
- X7.7.18 Plow is attached to the truck with 2 ears of 1 inch steel
- X7.7.18.1 Ears are on 31 inch centers
- X7.7.19 Is reversing achieved with two (2) industrial type cylinders with a 1 1/2 inch shaft, 3 inch barrel and a 18 inch stroke YES NO
- X7.7.19.1 Are cylinders protected with built in cushion valve YES NO
- X7.7.20 Does push frame pin to the mold board providing the capability of adjusting the cutting edge angle to the road after the plow has been attached to the truck YES NO
- X7.7.21 Is the lifting device a pulley and cable design to allow the plow to be raised with a minimum of Lift YES NO
- X7.7.22 Will all steel be sand blasted and painted YES NO
- X7.8 Control Valves:
- X7.8.1 Are control valves commercial YES NO
- X7.8.2 Are there six (6) section right front wing, right rear wing, right telescopic, left front wing, left rear wing, and left telescopic YES NO
- X7.8.3 Manufacturer and model of cab controls push pull cables: WESCON 08-5700-08
- X7.8.4 Do the controls for dump have built in lock out to prevent accidental actuation YES NO
- X7.8.5 Will you mount controls as directed by West Virginia Division of Highways Equipment Division YES NO
- X7.8.6 Do valves have a built in relief YES NO
- X7.9 Hoses and Fittings:
- X7.9.1 Are all hydraulic hoses and fittings JIC with o-ring boss thread adaptors YES NO

X7.9.2 Are hoses and fittings placed so as not to be damaged from rubbing or heat YES ___ NO

X7.9.3 Will hoses be wrapped with loom for protection as needed YES ___ NO

X7.10 Installation:

X7.10.1 Will equipment be mounted neatly on trucks furnished by Division of Highways YES ___ NO

X7.10.2 Will installation include all hoses, fittings, and other appurtenance required to have a complete and ready unit YES ___ NO

X7.10.3 Will plow lights be mounted top of plow frame with the system YES ___ NO

X7.10.4 Will all steel be sandblasted before primer and paint is applied YES ___ NO

X7.10.5 Will you have insurance to cover trucks while at mounting facility and during transport YES ___ NO

X7.11 All other features considered as standard:

X7.12 Will snowplow offered comply with OSHA OF 1970 and subsequent amendments YES ___ NO

X7.13 Will advertising conform to the guidelines YES ___ NO

X7.14 Will all loose hardware be in a separate container for each plow and shipped with each plow YES ___ NO

WV-96
Rev. 5/94

AGREEMENT ADDENDUM

In the event of conflict between this addendum and the agreement, this addendum shall control:

1. **ARBITRATION** - Any references to arbitration contained in the agreement are hereby deleted. Disputes arising out of the agreement shall be presented to the West Virginia Court of Claims.
2. **HOLD HARMLESS** - Any clause requiring the Agency to indemnify or hold harmless any party is hereby deleted in its entirety.
3. **GOVERNING LAW** - The agreement shall be governed by the laws of the State of West Virginia. This provision replaces any references to any other State's governing law.
4. **TAXES** - Provisions in the agreement requiring the Agency to pay taxes are deleted. As a State entity, the Agency is exempt from Federal, State, and local taxes and will not pay taxes for any Vendor including individuals, nor will the Agency file any tax returns or reports on behalf of Vendor or any other party.
5. **PAYMENT** - Any references to prepayment are deleted. Payment will be in arrears.
6. **INTEREST** - Should the agreement include a provision for interest on late payments, the Agency agrees to pay the maximum legal rate under West Virginia law. All other references to interest or late charges are deleted.
7. **RECOUPMENT** - Any language in the agreement waiving the Agency's right to set-off, counterclaim, recoupment, or other defense is hereby deleted.
8. **FISCAL YEAR FUNDING** - Service performed under the agreement may be continued in succeeding fiscal years for the term of the agreement, contingent upon funds being appropriated by the Legislature or otherwise being available for this service. In the event funds are not appropriated or otherwise available for this service, the agreement shall terminate without penalty on June 30. After that date, the agreement becomes of no effect and is null and void. However, the Agency agrees to use its best efforts to have the amounts contemplated under the agreement included in its budget. Non-appropriation or non-funding shall not be considered an event of default.
9. **STATUTE OF LIMITATION** - Any clauses limiting the time in which the Agency may bring suit against the Vendor, lessor, individual, or any other party are deleted.
10. **SIMILAR SERVICES** - Any provisions limiting the Agency's right to obtain similar services or equipment in the event of default or non-funding during the term of the agreement are hereby deleted.
11. **ATTORNEY FEES** - The Agency recognizes an obligation to pay attorney's fees or costs only when assessed by a court of competent jurisdiction. Any other provision is invalid and considered null and void.
12. **ASSIGNMENT** - Notwithstanding any clause to the contrary, the Agency reserves the right to assign the agreement to another State of West Virginia agency, board or commission upon thirty (30) days written notice to the Vendor and Vendor shall obtain the written consent of Agency prior to assigning the agreement.
13. **LIMITATION OF LIABILITY** - The Agency, as a State entity, cannot agree to assume the potential liability of a Vendor. Accordingly, any provision limiting the Vendor's liability for direct damages or limiting the Vendor's liability under a warranty to a certain dollar amount or to the amount of the agreement is hereby deleted. In addition, any limitation is null and void to the extent that it precludes any action for injury to persons or for damages to personal property.
14. **RIGHT TO TERMINATE** - Agency shall have the right to terminate the agreement upon thirty (30) days written notice to Vendor.
15. **TERMINATION CHARGES** - Any provision requiring the Agency to pay a fixed amount or liquidated damages upon termination of the agreement is hereby deleted. The Agency may only agree to reimburse a Vendor for actual costs incurred or losses sustained during the current fiscal year due to wrongful termination by the Agency prior to the end of any current agreement term.
16. **RENEWAL** - Any reference to automatic renewal is hereby deleted. The agreement may be renewed only upon mutual written agreement of the parties.
17. **INSURANCE** - Any provision requiring the Agency to insure equipment or property of any kind and name the Vendor as beneficiary or as an additional insured is hereby deleted.
18. **RIGHT TO NOTICE** - Any provision for repossession of equipment without notice is hereby deleted. However, the Agency does recognize a right of repossession with notice.
19. **ACCELERATION** - Any reference to acceleration of payments in the event of default or non-funding is hereby deleted.
20. **AMENDMENTS** - All amendments, modifications, alterations or changes to the agreement shall be in writing and signed by both parties. No amendment, modification, alteration or change may be made to this addendum without the express written approval of the Purchasing Division and the Attorney General.

ACCEPTED BY:
STATE OF WEST VIRGINIA

Spending Unit: _____

Signed: _____

Title: _____

Date: _____

VENDOR

Company Name: TENOR USA INC

Signed: Steven Laton

Title: Vice President

Date: 11/14/06



State of West Virginia
 Department of Administration
 Purchasing Division
 2019 Washington Street East
 Post Office Box 50130
 Charleston, WV 25305-0130

Request for Quotation

RFQ NUMBER
 707EC013

PAGE
 1

ADDRESS CORRESPONDENCE TO ATTENTION OF:
 JOHN JOHNSTON
 304-558-2402

*321105507 585-346-3040
 TENCO USA INC
 5700 SOUTH LIMA RD
 PO BOX 635
 LAKEVILLE NY 14480

VENDOR

SHIP TO

DIVISION OF HIGHWAYS
 EQUIPMENT DIVISION
 ROUTE 33
 BRUSHY FORK ROAD
 BUCKHANNON, WV
 26201 304-472-1750

DATE PRINTED 11/06/2006	TERMS OF SALE	SHIP VIA	F.O.B.	FREIGHT TERMS
BID OPENING DATE: 11/22/2006		BID OPENING TIME 01:30PM		

LINE	QUANTITY	UOP	CAT NO.	ITEM NUMBER	UNIT PRICE	AMOUNT
ADDENDUM NO. 1						
CHANGES TO THE SPECIFICATIONS PER THE ATTACHED.						
BID OPENING DATE AND TIME REMAINS THE SAME.						
NO OTHER CHANGES.						
0001	1	EA		765-61	32,158.00	32,158.00
FRONT WING MOUNTED SNOWPLOW (LEFT, CENTER, RIGHT)						
***** THIS IS THE END OF RFQ 707EC013 *****					TOTAL:	32,158.00

SEE REVERSE SIDE FOR TERMS AND CONDITIONS

SIGNATURE <i>Steven G. Johnston</i>	TELEPHONE 585-346-3040	DATE 11/14/06
TITLE V. Johnston	FEIN 16-1441499	ADDRESS CHANGES TO BE NOTED ABOVE

WHEN RESPONDING TO RFQ, INSERT NAME AND ADDRESS IN SPACE ABOVE LABELED 'VENDOR'

ADDENDUM #1
OPEN END CONTRACT
707EC013
FRONT MOUNTED WING SNOWPLOW (LEFT, CENTER, RIGHT)

CHANGES TO SPECIFICATIONS:

FROM:

7.5.3 The reset shall be with a rubber compression and not with coil spring

TO:

7.5.3 Trip section shall be reset after hitting an obstruction by torsion or by coil springs.

FROM:

7.7.2 Overall height of plow shall be maximum 42 inches

TO:

7.7.2 Overall height of plow should be approximately 42 inches

FROM:

7.7.6 Trip section shall be one (1) piece trip and shall become three (3) section by removing two (2) 1 inch section bolts allowing the cutting edge to be three (3) section trip.

TO:

7.7.6 Trip section should be designed to allow one (1) piece trip to become a multiple section trip; thus reducing shock to moldboard and extending life of plow.

ADDENDUM #1
 OPEN END CONTRACT
 707EC013
 FRONT MOUNTED WING SNOWPLOW (LEFT, CENTER, RIGHT)

CHANGES TO BIDDER'S EVALUATION REPORT:

FROM:

X7.5.3 Is reset with a rubber compression and not with coil spring YES NO

TO:

X7.5.3 Is trip section reset after hitting an obstruction by torsion or by coil springs
 YES NO

See attached

X7.7.2 No Change Required

FROM:

X7.7.6 Does trip section have one (1) piece trip and become three (3) section by removing two (2) 1 inch section bolts allowing the cutting edge to be three (3) section trip
 YES NO

TO:

X7.7.6 Is trip section designed to allow one (1) piece trip to become a multiple section trip; thus reducing shock to moldboard and extending life of plow
 YES NO

DBS PS

REQUISITION HEADER AND LINE COMMENTS

RCM

4

NEXT FUNCTION: _____ ACTION: _____

10/26/2006 10:53:46

REQUEST: _____ SAVE SHOW PAGE NO: _____

BUY ENTITY: PUR REQUISITION NO: 707EC011

CATALOG NO:

ITEM NO: e10

BEGINNING SEQUENCE NUMBER:

A/B C/D	REQ. LINE	SEQ NO.	COMMENTS/SPECIFICATIONS/INSTRUCTIONS	PRINT LINE
------------	--------------	------------	--------------------------------------	---------------

	95		EXHIBIT 10	Y
	100			Y
	105		REQUISITION NO.:	Y
	110			Y
	115		ADDENDUM ACKNOWLEDGEMENT	Y
	120			Y
	125		I HEREBY ACKNOWLEDGE RECEIPT OF THE FOLLOWING CHECKED	Y
	130		ADDENDUM(S) AND HAVE MADE THE NECESSARY REVISIONS TO MY	Y
	135		PROPOSAL, PLANS AND/OR SPECIFICATION, ETC.	Y
	140			Y
	145		ADDENDUM NO.'S:	Y
	150			Y
	155		NO. 1 <i>Sc...</i>	Y
	160			Y
	165		NO. 2 <i>Sc...</i>	Y
	170			Y
	175		NO. 3 <i>Sc...</i>	Y
	180			Y
	185		NO. 4 <i>Sc...</i>	Y
	190			Y
	195		NO. 5 <i>Sc...</i>	Y
	200			Y
	205		I UNDERSTAND THAT FAILURE TO CONFIRM THE RECEIPT OF THE	Y
	210		ADDENDUM(S) MAY BE CAUSE FOR REJECTION OF BIDS.	Y
	215			Y
	220		<i>Steven E. ...</i>	Y
	225		SIGNATURE	Y
	230			Y
	235		<i>Temco U.S.A. Inc.</i>	Y
	240		COMPANY	Y
	245			Y
	250		<i>11/24/06</i>	Y
	255		DATE	Y
	260			Y
	265			Y
	270		REV. 11/96	Y



November 17, 2006

Department of Administration
Purchasing Division
Attn: John Johnston
2019 Washington Street East
Post Office Box 50130
Charleston, WV 25305-0130

Dear Mr. Johnston,

Reference: RFQ# 707EC013

Please find enclosed addendum # 2. This addendum was received after my bid left my office therefore the return of this addendum is in a separate envelope.

Any questions please feel free to contact me at 800-808-3626.

Sincerely,

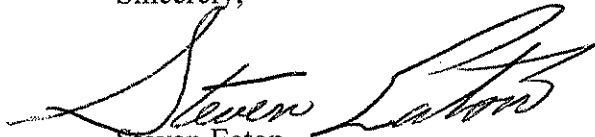

Steven Eaton
Vice President



State of West Virginia
 Department of Administration
 Purchasing Division
 2019 Washington Street East
 Post Office Box 50130
 Charleston, WV 25305-0130

Request for Quotation

RFO NUMBER
707EC013

PAGE
1

ADDRESS CORRESPONDENCE TO ATTENTION OF:
JOHN JOHNSTON 304-558-2402

*321105507 585-346-3040

VENDOR

TENCO USA INC
 5700 SOUTH LIMA RD
 PO BOX 635
 LAKEVILLE NY 14480

SHIP TO

DIVISION OF HIGHWAYS
 EQUIPMENT DIVISION
 ROUTE 33
 BRUSHY FORK ROAD
 BUCKHANNON, WV
 26201 304-472-1750

DATE PRINTED 11/13/2006	TERMS OF SALE	SHIP VIA	F.O.B.	FREIGHT TERMS
BID OPENING DATE: 11/22/2006		BID OPENING TIME 01:30PM		

LINE	QUANTITY	UOP	CAT NO.	ITEM NUMBER	UNIT PRICE	AMOUNT
ADDENDUM NO. 2						
SIGN IN SHEET AND AFFIDAVIT ATTACHED.						
BID OPENING DATE AND TIME REMAINS THE SAME.						
NO OTHER CHANGES.						
0001	1	EA		765-61		
FRONT WING MOUNTED SNOWPLOW (LEFT, CENTER, RIGHT)						
***** THIS IS THE END OF RFO 707EC013 ***** TOTAL:						

SEE REVERSE SIDE FOR TERMS AND CONDITIONS

SIGNATURE <i>Steven ...</i>	TELEPHONE 585-346-3040	DATE 11/17/06
TITLE <i>...</i>	FEIN 16-1441499	ADDRESS CHANGES TO BE NOTED ABOVE

WHEN RESPONDING TO RFO, INSERT NAME AND ADDRESS IN SPACE ABOVE LABELED 'VENDOR'

SIGN IN SHEET

Page 1 of

RF# 70TECO13

Date 11/9/06

Firm & Representative Name:

Mailing Address:

Phone&Fax#:

1. DAVE TINCER

PURCHASING

P

F

2. WV TRACTOR

P.O. BOX 473

346-5301

Gary Gray

CHARLESTOWN WV 25372

346-5305

3. Tenco USA

Fakeville N.Y.

800-505-3626

Ken Brink

Manticello N.Y. 12701

845-798-9525

4. Angie Moorhead

DOH

558-9427

5. Andy Perrin

722 Riggs Rd.

814-444-7040

JJ TRUCK

Somerset PA 15331

814-445-3726

6. John Walker

WV DOH

558-6264

7. Tara Cochran

DOH

473-5327

Please print or write legibly!
Your Fax # is essential to contact you timely!

SIGN IN SHEET

Page ___ of ___

RF# _____
Date _____

Firm & Representative Name:

Mailing Address:

Phone&Fax#:

1. Don Weese

DOT

P 473-5362

F _____

2. Michael Austin

Purchasing

558-2316

3. Bret Chittum

Purchasing

558-8806

4. Shirley Blount

Purchasing

558-3488

5. Shelly Murty

Purchasing

558-8801

6. SHANE HALL

Purchasing

558-8803

7. _____

Please print or write legibly!

Your Fax # is essential to contact you timely!

AFFIDAVIT

West Virginia Code §5A-3-10a states:

No contract or renewal of any contract may be awarded by the state or any of its political subdivisions to any vendor or prospective vendor when the vendor or prospective vendor or a related party to the vendor or prospective vendor is a debtor and the debt owned is an amount greater than one thousand dollars in the aggregate

DEFINITIONS:

"Debt" means any assessment, premium, penalty, fine, tax or other amount of money owed to the state or any of its political subdivisions because of a judgment, fine, permit violation, license assessment, defaulted workers' compensation premium, penalty or other assessment presently delinquent or due and required to be paid to the state or any of its political subdivisions, including any interest or additional penalties accrued thereon.

"Debtor" means any individual, corporation, partnership, association, limited liability company or any other form or business association owing a debt to the state or any of its political subdivisions. "Political subdivision" means any county commission; municipality; county board of education; any instrumentality established by a county or municipality; any separate corporation or instrumentality established by one or more counties or municipalities, as permitted by law; or any public body charged by law with the performance of a government function or whose jurisdiction is coextensive with one or more counties or municipalities. "Related party" means a party, whether an individual, corporation, partnership, association, limited liability company or any other form or business association or other entity whatsoever, related to any vendor by blood, marriage, ownership or contract through which the party has a relationship of ownership or other interest with the vendor so that the party will actually or by effect receive or control a portion of the benefit, profit or other consideration from performance of a vendor contract with the party receiving an amount that meets or exceed five percent of the total contract amount.

EXCEPTION:

The prohibition of this section does not apply where a vendor has contested any tax administered pursuant to chapter eleven of this code, workers' compensation premium, permit fee or environmental fee or assessment and the matter has not become final or where the vendor has entered into a payment plan or agreement and the vendor is not in default of any of the provisions of such plan or agreement.

LICENSING:

Vendors must be licensed and in good standing in accordance with any and all state and local laws and requirements by any state or local agency of West Virginia, including, but not limited to, the West Virginia Secretary of State's Office, the West Virginia Tax Department, West Virginia Insurance Commission, or any other state agencies or political subdivision. Furthermore, the vendor must provide all necessary releases to obtain information to enable the Director or spending unit to verify that the vendor is licensed and in good standing with the above entities.

CONFIDENTIALITY:

The vendor agrees that he or she will not disclose to anyone, directly or indirectly, any such personally identifiable information or other confidential information gained from the agency, unless the individual who is the subject of the information consents to the disclosure in writing or the disclosure is made pursuant to the agency's policies, procedures and rules. Vendors should visit www.state.wv.us/admin/purchase/privacy for the Notice of Agency Confidentiality Policies.

Under penalty of law for false swearing (West Virginia Code, §61-5-3), it is hereby certified that the vendor acknowledges the information in this said affidavit and are in compliance with the requirements as stated.

Vendor's Name: Tenco U.S.A. inc.

Authorized Signature: Steven Lambert Date: 11/17/06

Non-collusive bidders certificate

pursuant to chapter 675, law of 1966

[A] by submission of this bid, each bidder and each person signing on behalf of any bidder certifies, and in the case of joint bid each party there to certifies as to its own organization, under penalty of perjury, that to the best of knowledge and belief:

1] The prices in this bid have been arrived at independently without collusion, consultation, communication, or agreement, for the purpose of restricting competition, as to any matter relating to such prices with any other bidder or with any competitor.

2] Unless otherwise required by law, the prices which have been quoted in this bid have not been knowingly disclosed by the bidder and with not knowingly be disclosed by the bidder prior to opening, directly or indirectly, to any other bidder or to any competitor; and

3] No attempt has been made or will be made by the bidder to include any other person, partnership or corporation to submit or not submit a bid for the purpose of restricting competition.

Name of Bidder: TERCO USA INC

Signature of Bidder: [Handwritten Signature]

Date: 11/14/06

WARRANTY POLICY FOR TENCO PRODUCTS 2001

WARRANTY COVERAGE

- Warranty starts on day of delivery to the owner.
- Warranty is void unless the warranty registration certificate has been completed and returned to Tenco Machinery (CDN) Ltd's office within 30 days of delivery.
- All other warranties mentioned in the sales contract will be honored.

WARRANTY RUNAWAY SWEEPER

- Complete unit: 1 year parts & labour

WARRANTY ONE-WAY, PLOW, WING, UNDERBODY

- Complete unit: 2 year parts & labour

WARRANTY 12M BODY

- Complete unit: 1 year parts & labour

WARRANTY HOPPER SPREADER

- Complete unit: 1 year parts & labour

WARRANTY SELF-PROPELLED SNOWBLOWER

- Complete unit: 1 year parts & labour

WARRANTY DETACHABLE SNOWBLOWER

- Complete unit: 1 year parts & labour

EXPIRATION

- Warranty expiration will be based on years or hours whichever occurs first.

WARRANTY POLICY FOR TENCO PRODUCTS 2001

POLICY

CDN WARRANTY 2001 – 2002

TENCO MANUFACTURING WARRANTY

Tenco Machinery (CDN) Ltd's objective is to insure that all owners obtain maximum reliability and performance from their snow removal equipment.

- Tenco Machinery (CDN) Ltd warrants its new products (when properly assembled, adjusted, maintained and operated) to be free of defects in material and workmanship for the applicable warranty period.
- Tenco Machinery (CDN) Ltd's obligation under this warranty is limited to repairing or replacing F.O.B. Tenco Machinery (CDN) Ltd's factory any part or parts which are reported defective, given all details by the Tenco Machinery (CDN) Ltd authorised dealer or person, within 30 days from date of failure. In no event will Tenco Machinery (CDN) Ltd assume any responsibility for consequential damages to material of any nature or source resulting from defects in materials or parts which are not manufactured by Tenco Machinery (CDN) Ltd (truck, pick-up truck, loader, etc).
- Transportation costs are the responsibility of the owner, at the owner's expense, to transport the equipment to the service shop of an authorised Tenco Machinery (CDN) Ltd dealer or alternatively to reimburse the dealer for any travel or transportation expense involved in fulfilling this warranty..
- Anytime there is a metal structure or weld problem, photos have to be taken and attached to the warranty claim.
- Tenco Machinery (CDN) Ltd reserves the right to make changes or make improvements at any time without notice or obligation.
- All warranty claims must be submitted to Tenco Machinery (CDN) Ltd's office within 30 days after repairs have been completed. Any warranty claim submitted after 60 days have no priority and will be processed as time permits.

PENTURE - HINGE 4-8-30 Deg.

P48R

P48G

215 22 0031 DROITE - R.H.
215 22 0039 GAUCHE - L.H.

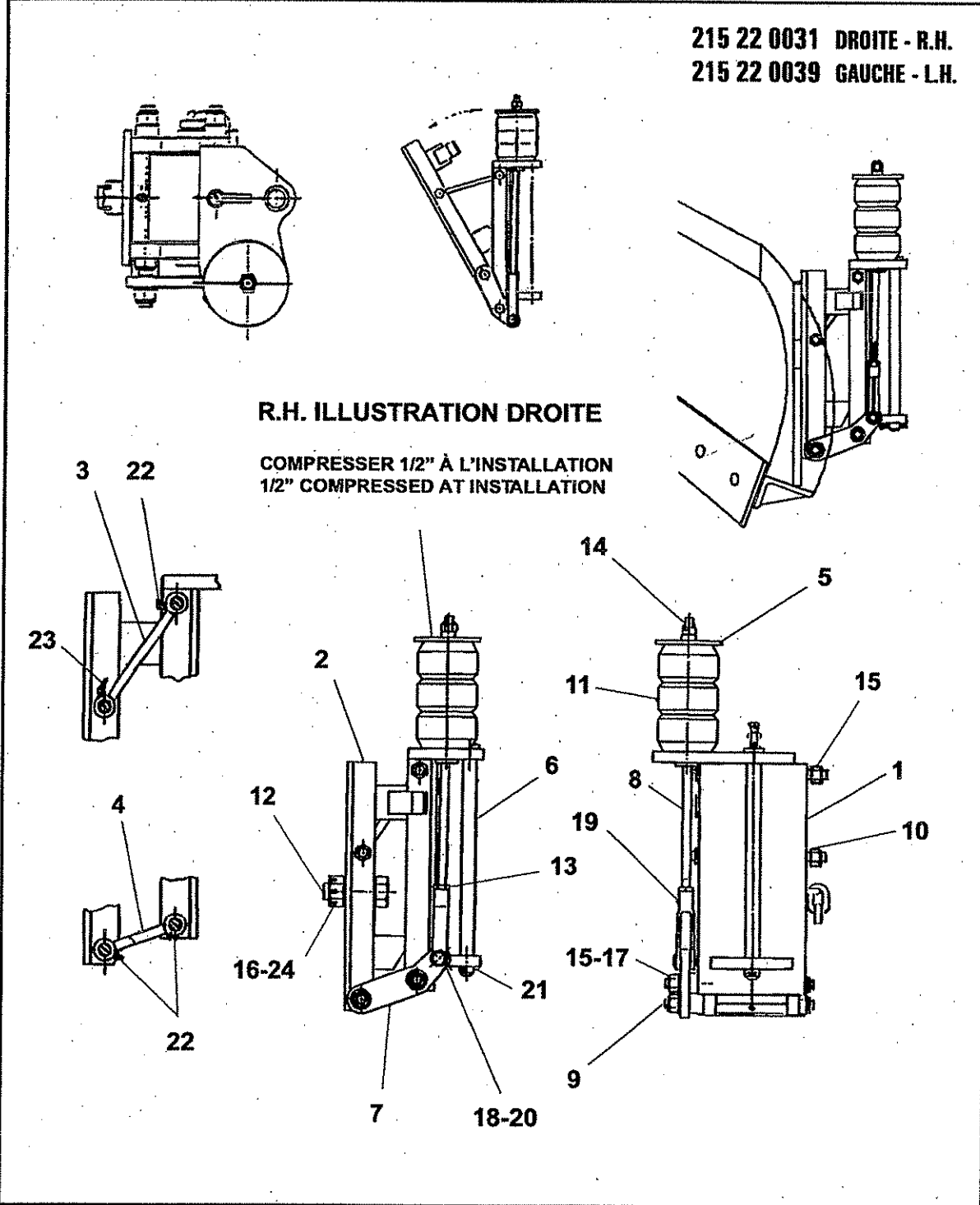

20010827

POUR COMMANDE SPÉCIFIER
POUR INSTALLATION GAUCHE OU DROITE

FOR ORDERING PARTS SPECIFY
FOR R.H. OR L.H. INSTALLATION

215001 AIL 008



PENTURE - HINGE 4-8-30 deg.

P48R
P48G

DROITE-R.H. 215 22 0031
GAUCHE-L.H. 215 22 0039

ILL.	ITEM	QT	DESCRIPTION	
1	215 20 0083	1	SUPPORT DROIT CÔTÉ COLONNE	R.H. SUPPORT POST SIDE
	215 20 0094	1	SUPPORT GAUCHE " "	L.H. " " " "
2	215 20 0084	1	SUPPORT DROIT CÔTÉ AILE	R.H. SUPPORT SIDE WING SIDE
	215 20 0095	1	SUPPORT GAUCHE " "	L.H. " " " "
3	215 20 0085	1	BRAS LONG	LONG ARM
4	215 20 0086	1	BRAS COURT	SMALL ARM
5	215 20 0057	1	GUIDE DE RESSORT	SPRING GUIDE
6	215 20 0091	1	GOUJON D'ATTACHE	ATTACH PIN
7	215 20 0165	2	LEVIER DROIT	R.H. SWIVEL PLATE
	215 20 0166	2	" GAUCHE	L.H. " " "
8	215 19 0302	1	TIGE FILETÉE	THREADED ROD
9	215 19 0231	1	GRANDE TIGE	LONG ROD
10	215 19 0232	1	PETITE TIGE	SMALL ROD
11	215 28 0003	1	RESSORT CAOUTCHOUC "AEON"	RUBBER SPRING
12	215 29 0003	4	HEX. BOULON 1 1/2 NC-4 1/2" LG.	HEX. BOLT 1 1/2 NC-4 1/2" LG.
13	2407	1	HEX. ÉCROU 3/4 NF	HEX. NUT 3/4 NF
14	2438	2	HEX. ÉCROU AUTO 3/4 NF	HEX. LOCK NUT 3/4 NF
15	2473	1	"STOVER" ÉCROU AUTO 7/8 NF GR8	"STOVER" LOCK NUT 7/8 NF GR8
16	2515	1	ÉCROU À CRENAUX 1 1/2 NC	CASTLE NUT 1 1/2 NC
17	5349	2	RONDELLE PLATE 7/8" DIA. (GR.-PLAQUÉE)	FLAT WASHER 7/8" DIA. (GR.-PLATED)
18	5011	1	GOUJON DE CHAPE	PIN FOR YOKE
19	5012	2	CHAPE	YOKE
20	-	2	GOUPILLE FENDUE 3/32" DIA. X 1 1/4" LG.	COTTER PIN 3/32" DIA. X 1 1/4" LG.
21	9625	1	GOUPILLE FENDUE 5/16" DIA. X 2" LG.	COTTER PIN 5/16" DIA. X 2" LG.
22	9635	1	GRAISSEUR DROIT 1/4-28	STRAIGHT ZERK 1/4-28
23	9638	1	GRAISSEUR 45 deg. 1/4-28	ZERK 45 deg. 1/4-28
24	9627	1	GOUPILLE FENDUE 5/16" DIA. X 4" LG.	COTTER PIN 5/16" DIA. X 4" LG.



COPY

JOE MANCHIN III
GOVERNOR

STATE OF WEST VIRGINIA
DEPARTMENT OF ADMINISTRATION
PURCHASING DIVISION
2019 WASHINGTON STREET, EAST
P.O. BOX 50130
CHARLESTON, WEST VIRGINIA 25305-0130

ROBERT W. FERGUSON, JR.
CABINET SECRETARY

DAVID TINCHER
DIRECTOR

March 21, 2006

Steven Eaton
Tenco (USA), Inc.
5700 South Lima Rd.
PO Box 635
Lakeville, NY 14480

Dear Mr. Eaton:

We received your vendor registration application and check in the amount of \$45.00 to become a registered vendor to do business with the State of West Virginia. This is to inform you that we have processed your application and your company is now eligible to participate in the competitive bid process to receive purchase orders from state agencies. If there is a change within your organization, please notify us immediately to update your vendor status with the Purchasing Division.

Payment of the \$45.00 fee entitles you to a year's subscription to the **West Virginia Purchasing Bulletin**, which advertises bidding opportunities expected to exceed \$10,000. A new issue is posted on our website weekly at www.state.wv.us/admin/purchase. We encourage you to view this publication on a regular basis so as not to miss important bidding opportunities. Printed copies will not be mailed but one will be posted in the Purchasing Division's reception room available to vendors.

In order to access the Purchasing Bulletin on the Internet, you will need your **vendor number** and **password**, which is listed below. Your password is the check number used to pay the current fee. A group number is not required unless indicated below. The vendor file is updated every Monday. As a new vendor, you should be able to access the Bulletin on the Internet after **March 27, 2006**.

If you have any questions concerning the vendor registration process, please feel free to contact me at any time at 304-558-2311 or evance@wvadmin.gov.

Sincerely,

Erika Vance, Vendor Registration
Administration & Inspection Section
WV Purchasing Division

Vendor Number:

Group Number:

Password

*321105507

14695