



State of West Virginia
 Department of Administration
 Purchasing Division
 2019 Washington Street East
 Post Office Box 50130
 Charleston, WV 25305-0130

Request for Quotation

RFQ NUMBER
 707EC008

PAGE
 1

ADDRESS CORRESPONDENCE TO ATTENTION OF:
 JOHN JOHNSTON
 304-558-2402

RFQ COPY

TYPE NAME/ADDRESS HERE

VENDOR

Valley Air Inc.
 P.O. Box 6516
 Charleston, WV 25362

SHIP TO

DIVISION OF HIGHWAYS
 EQUIPMENT DIVISION
 ROUTE 33
 BRUSHY FORK ROAD
 BUCKHANNON, WV
 26201 304-472-1750

DATE PRINTED	TERMS OF SALE	SHIP VIA	F.O.B.	FREIGHT TERMS
08/24/2006	Net 30 Days	Motor Truck	Buckhannon WV	Prepaid

BID OPENING DATE: 10/04/2006 BID OPENING TIME 01:30PM

LINE	QUANTITY	UOP	CAT NO.	ITEM NUMBER	UNIT PRICE	AMOUNT
0001	1	EA		760-66	30,937.64	30,937.64
DOUBLE DRUM VIBRATORY ROLLER/COMPACTOR OPEN END CONTRACT TO PROVIDE DOUBLE DRUM VIBRATORY ROLLER/COMPACTOR AS DESCRIBED IN ATTACHED PROCUREMENT SPECIFICATION 591-2-K. THERE WILL BE A MANDATORY PRE-BID CONFERENCE AT THE STATE CAPITOL COMPLEX, BUILDING 15, CONFERENCE ROOM, AT 10:00 AM ON 9/22/06. FAILURE TO ATTEND THE PRE-BID CONFERENCE WILL RESULT IN BID DISQUALIFICATION. QUESTIONS: WRITTEN QUESTIONS WILL BE ACCEPTED THROUGH CLOSE OF BUSINESS (5:00PM EST) ON WEDNESDAY 9/13/06. SEND YOUR QUESTIONS TO: PURCHASING DIVISION ATTENTION JOHN JOHNSTON 2019 WASHINGTON ST. E. CHARLESTON, WV. 25305 QUESTIONS MAY BE SENT VIA FAX, E-MAIL, OR REGULAR MAIL E-MAIL: JJOHNSTON@WVADMIN.GOV FAX: 304-558-4115 IT IS THE VENDORS RESPONSIBILITY TO VERIFY THAT THEIR QUESTIONS HAVE BEEN RECEIVED BY CALLING 304-558-2402. EXHIBIT 2 LIFE OF CONTRACT: THIS CONTRACT BECOMES EFFECTIVE ON AND EXTENDS FOR A PERIOD OF ONE (1) YEAR OR UNTIL SUCH "REASONABLE TIME" THEREAFTER AS IS NECESSARY TO OBTAIN A NEW CONTRACT OR RENEW THE ORIGINAL CONTRACT. THE "REASONABLE TIME" PERIOD SHALL						

SEE REVERSE SIDE FOR TERMS AND CONDITIONS

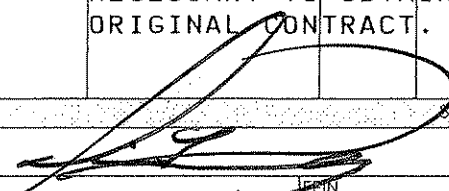
SIGNATURE  TELEPHONE (800) 435-9959 DATE 10/02/06
 TITLE Sales Representative FEIN 55-065-9314-001 ADDRESS CHANGES TO BE NOTED ABOVE

WHEN RESPONDING TO RFQ, INSERT NAME AND ADDRESS IN SPACE ABOVE LABELED 'VENDOR'



State of West Virginia
 Department of Administration
 Purchasing Division
 2019 Washington Street East
 Post Office Box 50130
 Charleston, WV 25305-0130

Request for Quotation

RFQ NUMBER
 707EC008

PAGE
 2

ADDRESS CORRESPONDENCE TO ATTENTION OF
 JOHN JOHNSTON
 304-558-2402

RFQ COPY

TYPE NAME/ADDRESS HERE

VENDOR

Valley Air Inc.
 P.O. Box 6516
 Charleston, WV 25362

SHIP TO

DIVISION OF HIGHWAYS
 EQUIPMENT DIVISION
 ROUTE 33
 BRUSHY FORK ROAD
 BUCKHANNON, WV
 26201 304-472-1750

DATE PRINTED 08/24/2006	TERMS OF SALE Net 30 Days	SHIP VIA Motor Truck	F.O.B. Buckhannon WV	FREIGHT TERMS Prepaid
----------------------------	------------------------------	-------------------------	-------------------------	--------------------------

BID OPENING DATE: 10/04/2006 BID OPENING TIME 01:30PM

LINE	QUANTITY	UOP	CAT NO.	ITEM NUMBER	UNIT PRICE	AMOUNT
<p>NOT EXCEED TWELVE (12) MONTHS. DURING THIS "REASONABLE TIME" THE VENDOR MAY TERMINATE THIS CONTRACT FOR ANY REASON UPON GIVING THE DIRECTOR OF PURCHASING THIRTY (30) DAYS WRITTEN NOTICE.</p> <p>UNLESS SPECIFIC PROVISIONS ARE STIPULATED IN THIS CONTRACT DOCUMENT, THE TERMS, CONDITIONS, AND PRICING SET HEREIN ARE FIRM FOR THE LIFE OF THE CONTRACT.</p> <p>RENEWAL: THIS CONTRACT MAY BE RENEWED UPON THE MUTUAL WRITTEN CONSENT OF THE SPENDING UNIT AND VENDOR, SUBMITTED TO THE DIRECTOR OF PURCHASING THIRTY (30) DAYS PRIOR TO THE EXPIRATION DATE. SUCH RENEWAL SHALL BE IN ACCORDANCE WITH THE TERMS AND CONDITIONS OF THE ORIGINAL CONTRACT AND SHALL BE LIMITED TO TWO (2) ONE (1) YEAR PERIODS.</p> <p>CANCELLATION: THE DIRECTOR OF PURCHASING RESERVES THE RIGHT TO CANCEL THIS CONTRACT IMMEDIATELY UPON WRITTEN NOTICE TO THE VENDOR IF THE COMMODITIES AND/OR SERVICES SUPPLIED ARE OF AN INFERIOR QUALITY OR DO NOT CONFORM WITH THE SPECIFICATIONS OF THE BID AND CONTRACT HEREIN.</p> <p>OPEN MARKET CLAUSE: THE DIRECTOR OF PURCHASING MAY AUTHORIZE A SPENDING UNIT TO PURCHASE ON THE OPEN MARKET, WITHOUT THE FILING OF A REQUISITION OR COST ESTIMATE, ITEMS SPECIFIED ON THIS CONTRACT FOR IMMEDIATE DELIVERY IN EMERGENCIES DUE TO UNFORESEEN CAUSES (INCLUDING BUT NOT LIMITED TO DELAYS IN TRANSPORTATION OR AN UNANTICIPATED INCREASE IN THE VOLUME OF WORK).</p> <p>QUANTITIES: QUANTITIES LISTED IN THE REQUISITION ARE APPROXIMATIONS ONLY, BASED ON ESTIMATES SUPPLIES BY THE STATE SPENDING UNIT. IT IS UNDERSTOOD AND AGREED THAT THE CONTRACT SHALL COVER THE QUANTITIES ACTUALLY ORDERED FOR DELIVERY DURING THE TERM OF CONTRACT,</p>						

SEE REVERSE SIDE FOR TERMS AND CONDITIONS

SIGNATURE 	TELEPHONE (800) 435-9959	DATE 10/02/06
TITLE Sales Representative	55-065-9314-001	ADDRESS CHANGES TO BE NOTED ABOVE

WHEN RESPONDING TO RFQ, INSERT NAME AND ADDRESS IN SPACE ABOVE LABELED 'VENDOR'



State of West Virginia
 Department of Administration
 Purchasing Division
 2019 Washington Street East
 Post Office Box 50130
 Charleston, WV 25305-0130

Request for Quotation

RFQ NUMBER
 707EC008

PAGE
 4

ADDRESS CORRESPONDENCE TO ATTENTION OF:
 JOHN JOHNSTON
 304-558-2402

RFQ COPY

TYPE NAME/ADDRESS HERE

V
E
N
D
O
R

Valley Air Inc.
 P.O. Box 6516
 Charleston, WV 25362

S
H
I
P
T
O

DIVISION OF HIGHWAYS
 EQUIPMENT DIVISION
 ROUTE 33
 BRUSHY FORK ROAD
 BUCKHANNON, WV
 26201 304-472-1750

DATE PRINTED 08/24/2006	TERMS OF SALE Net 30 Days	SHIP VIA Motor Truck	F.O.B. Buckhannon WV	FREIGHT TERMS Prepaid
----------------------------	------------------------------	-------------------------	-------------------------	--------------------------

BID OPENING DATE: 10/04/2006 BID OPENING TIME 01:30PM

LINE	QUANTITY	UOP	CAT NO	ITEM NUMBER	UNIT PRICE	AMOUNT
<p>PUBLISHED PRICE LISTS. SUCH REQUESTS FOR AND INCREASE SHOULD BE RECEIVED IN WRITING BY THE DIRECTOR OF PURCHASING AT LEAST 30 DAYS IN ADVANCE OF THE EFFECTIVE DATE OF THE INCREASE. ANY TIME THE VENDOR REQUESTS A PRICE ADJUSTMENT, THE PURCHASING DIVISION MAY EITHER ACCEPT THE PRICE ADJUSTMENT AND AMEND THE CONTRACT ACCORDINGLY OR REJECT THE ADJUSTMENT IN ITS ENTIRETY AND CANCEL THE CONTRACT.</p> <p>VENDOR PREFERENCE CERTIFICATE</p> <p>CERTIFICATION AND APPLICATION* IS HEREBY MADE FOR PREFERENCE IN ACCORDANCE WITH WEST VIRGINIA CODE, 5A-3-37 (DOES NOT APPLY TO CONSTRUCTION CONTRACTS).</p> <p>A. APPLICATION IS MADE FOR 2.5% PREFERENCE FOR THE REASON CHECKED:</p> <p>() BIDDER IS AN INDIVIDUAL RESIDENT VENDOR AND HAS RESIDED CONTINUOUSLY IN WEST VIRGINIA FOR FOUR (4) YEARS IMMEDIATELY PRECEDING THE DATE OF THIS CERTIFICATION; OR</p> <p>(XX) BIDDER IS A PARTNERSHIP, ASSOCIATION OR CORPORATION RESIDENT VENDOR AND HAS MAINTAINED ITS HEAD-QUARTERS OR PRINCIPAL PLACE OF BUSINESS CONTINUOUSLY IN WEST VIRGINIA FOR FOUR (4) YEARS IMMEDIATELY PRECEDING THE DATE OF THIS CERTIFICATION; OR 80% OF THE OWNERSHIP INTEREST OF BIDDER IS HELD BY ANOTHER INDIVIDUAL, PARTNERSHIP, ASSOCIATION OR CORPORATION RESIDENT VENDOR WHO HAS MAINTAINED ITS HEADQUARTERS OR PRINCIPAL PLACE OF BUSINESS CONTINUOUSLY IN WEST VIRGINIA FOR FOUR (4) YEARS IMMEDIATELY PRECEDING THE DATE OF THIS CERTIFICATION; OR</p> <p>() BIDDER IS A CORPORATION NONRESIDENT VENDOR</p>						

SEE REVERSE SIDE FOR TERMS AND CONDITIONS

SIGNATURE TELEPHONE (800) 435-9959 DATE 10/02/06
 TITLE Sales Representative FEIN 55-065-9314-001 ADDRESS CHANGES TO BE NOTED ABOVE

WHEN RESPONDING TO RFQ, INSERT NAME AND ADDRESS IN SPACE ABOVE LABELED 'VENDOR'



State of West Virginia
 Department of Administration
 Purchasing Division
 2019 Washington Street East
 Post Office Box 50130
 Charleston, WV 25305-0130

Request for Quotation

RFQ NUMBER
707EC008

PAGE
6

ADDRESS CORRESPONDENCE TO ATTENTION OF:
JOHN JOHNSTON 304-558-2402

RFQ COPY
 TYPE NAME/ADDRESS HERE

Valley Air Inc.
 P.O. Box 6516
 Charleston, WV 25362

DIVISION OF HIGHWAYS
 EQUIPMENT DIVISION
 ROUTE 33
 BRUSHY FORK ROAD
 BUCKHANNON, WV
 26201 304-472-1750

DATE PRINTED	TERMS OF SALE	SHIP VIA	F.O.B.	FREIGHT TERMS
08/24/2006	Net 30 Days	Motor Truck	Buckhannon WV	Prepaid

BID OPENING DATE: 10/04/2006 BID OPENING TIME 01:30PM

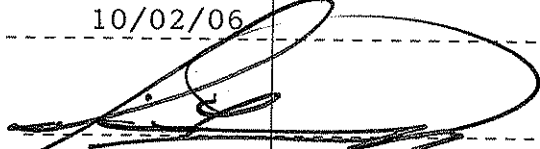
LINE	QUANTITY	UOP	CAT. NO.	ITEM NUMBER	UNIT PRICE	AMOUNT
<p>AND THAT SUCH PENALTY WILL BE PAID TO THE CONTRACTING AGENCY OR DEDUCTED FROM ANY UNPAID BALANCE ON THE CONTRACT OR PURCHASE ORDER.</p> <p>BY SUBMISSION OF THIS CERTIFICATE, BIDDER AGREES TO DISCLOSE ANY REASONABLY REQUESTED INFORMATION TO THE PURCHASING DIVISION AND AUTHORIZES THE DEPARTMENT OF TAX AND REVENUE TO DISCLOSE TO THE DIRECTOR OF PURCHASING APPROPRIATE INFORMATION VERIFYING THAT BIDDER HAS PAID THE REQUIRED BUSINESS TAXES, PROVIDED THAT SUCH INFORMATION DOES NOT CONTAIN THE AMOUNTS OF TAXES PAID NOR ANY OTHER INFORMATION DEEMED BY THE TAX COMMISSIONER TO BE CONFIDENTIAL.</p> <p>UNDER PENALTY OF LAW FOR FALSE SWEARING (WEST VIRGINIA CODE 61-5-3), BIDDER HEREBY CERTIFIES THAT THIS CERTIFICATE IS TRUE AND ACCURATE IN ALL RESPECTS; AND THAT IF A CONTRACT IS ISSUED TO BIDDER AND IF ANYTHING CONTAINED WITHIN THIS CERTIFICATE CHANGES DURING THE TERM OF THE CONTRACT, BIDDER WILL NOTIFY THE PURCHASING DIVISION IN WRITING IMMEDIATELY.</p> <p>BIDDER: Valley Air Inc.</p> <p>DATE: 10/02/06</p> <p>SIGNED:  Jim Pauley</p> <p>TITLE: Sales Representative</p> <p>* CHECK ANY COMBINATION OF PREFERENCE CONSIDERATION(S) IN EITHER "A" OR "B", OR BOTH "A" AND "B" WHICH YOU AR</p>						

SEE REVERSE SIDE FOR TERMS AND CONDITIONS

SIGNATURE	TELEPHONE	DATE
	(800) 435-9959	10/02/06
TITLE	FEIN	ADDRESS CHANGES TO BE NOTED ABOVE
Sales Representative	55-065-9314-001	

WHEN RESPONDING TO RFQ, INSERT NAME AND ADDRESS IN SPACE ABOVE LABELED 'VENDOR'



State of West Virginia
 Department of Administration
 Purchasing Division
 2019 Washington Street East
 Post Office Box 50130
 Charleston, WV 25305-0130

Request for Quotation

RFQ NUMBER
707EC008

PAGE
8

ADDRESS CORRESPONDENCE TO ATTENTION OF
JOHN JOHNSTON
304-558-2402

RFQ COPY

TYPE NAME/ADDRESS HERE

VENDOR

Valley Air Inc.
 P.O. Box 6516
 Charleston, WV 25362

SHIP TO

DIVISION OF HIGHWAYS
 EQUIPMENT DIVISION
 ROUTE 33
 BRUSHY FORK ROAD
 BUCKHANNON, WV
 26201 304-472-1750

DATE PRINTED 08/24/2006	TERMS OF SALE Net 30 Days	SHIP VIA Motor Truck	F.O.B. Buckhannon WV	FREIGHT TERMS Prepaid
-----------------------------------	-------------------------------------	--------------------------------	--------------------------------	---------------------------------

BID OPENING DATE: **10/04/2006** BID OPENING TIME: **01:30PM**

LINE	QUANTITY	UOP	CAT. NO.	ITEM NUMBER	UNIT PRICE	AMOUNT
CONTACT PERSON (PLEASE PRINT CLEARLY): ----- Jim Pauley -----						
***** THIS IS THE END OF RFQ 707EC008 ***** TOTAL:						<u>30,937.64</u>

SEE REVERSE SIDE FOR TERMS AND CONDITIONS

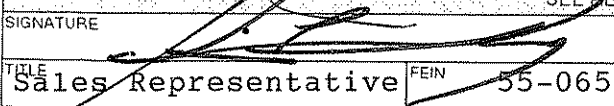
SIGNATURE:  TELEPHONE: **(800) 435-9959** DATE: **10/02/06**
 TITLE: **Sales Representative** FEIN: **55-065-9314-001** ADDRESS CHANGES TO BE NOTED ABOVE

WHEN RESPONDING TO RFQ, INSERT NAME AND ADDRESS IN SPACE ABOVE LABELED 'VENDOR'

WEST VIRGINIA DEPARTMENT OF TRANSPORTATION
DIVISION OF HIGHWAYS
EQUIPMENT DIVISION

PROCUREMENT SPECIFICATIONS
NO. 591-2-K

DOUBLE DRUM VIBRATORY ROLLER/COMPACTOR

1.0 PURPOSE

It is the purpose of these specifications to describe a Double Drum Vibratory Roller/Compactor (hereinafter referred to as a "roller" or a "unit") to be purchased for use by the West Virginia Division of Highways (DOH) on an Open End Contract basis.

2.0 BIDDING PROCEDURES

The current purchasing procedures regarding bidding as established by the Department of Administration, Purchasing Division, shall apply. Failure to submit the "Request for Quotation" forms, complete in its entirety and according to directions indicated, may subject the bidder to disqualification. Each bid submitted shall also be accompanied by a Bidder's Evaluation Report completed in detail. FAILURE TO SUBMIT THE BIDDER'S EVALUATION REPORT, COMPLETE IN ITS ENTIRETY, MAY RESULT IN AUTOMATIC DISQUALIFICATION.

3.0 SPECIFICATIONS

The specifications named herein, mandatory and non-mandatory, establish the acceptable level of quality only and are not intended to reflect a preference or favor any particular brand or vendor.

3.1 EXCEPTIONS TO NON-MANDATORY SPECIFICATIONS

Exception to a non-mandatory unit specification may be made by the bidder, providing the exception is not available from the manufacturer. Any such exception must be noted on the bidder's evaluation report and should be accompanied by supporting documentation/literature from the manufacturer. Any exception must be indicated on a separate attachment to the bidder's evaluation report and labeled as "Exception to Specifications". The state reserves the right to determine whether the stated exception does or does not reduce the quality and performance of the unit. Failure to provide information for any exceptions may be grounds for rejection of the bid. The state reserves the right to waive minor irregularities in bids or specifications in accordance with §148-1-4(f) of the WV Legislative Rules and Regulations.

confirmation of the order to the WVDOH contact person within seven (7) working days after receiving the approved purchase order.

A completed pilot model for inspection must be provided within 30 calendar days after the date of the purchase agreement by the successful vendor.

Delivery is an integral part of this specification and failure to comply will be cause to initiate a D.O.T. Administrative Form WV-82, Vendor Performance Form. The WV-82 Form will provide a means of officially notifying the Purchasing Division and the vendor of unsatisfactory performance; such as late deliveries, poor service, inadequate parts supplies, etc.

The decision to initiate subject Form will be at the sole discretion of the D.O.H. Commissioner's established Equipment Review Board.

Issuance of the WV-82 Vendor Complaint Form on unsatisfactory delivery against any vendor will be cause to refuse to consider similar items from those vendors on future Request For Quotations.

(NOTE: Delivery time could be altered due to labor strikes, severe inclement weather conditions, etc.)

5.0 AWARD CRITERIA

- 5.1 DOH will recommend the award in accordance with the RFQ evaluation criteria described in the requisition. The award shall be made to the lowest unit cost vendor that meets or exceeds the specifications.

Prices for the units shall be in quantities of 1-10, 11-20, and 21 and over. However, for evaluation purposes, we will use quantities 1-10. DOH reserves the right to place multiple orders in any quantity.

6.0 SPECIFICATIONS AND GUIDELINES - GENERAL

6.1 IDENTIFICATION OF THE UNIT BEING PROPOSED

The bidder must identify the unit by manufacturer, model, series, and year of manufacture, in the bid to enable identification by DOH in the manufacturer's specifications of the proposed unit. The bidder will submit complete descriptive literature of the proposed unit, to establish that the bid is the manufacturer's most current model, including latest engineering improvements, which have been, or will imminently be, regularly advertised and sold on the open market. The unit specified herein and offered to be manufactured after January 1, 2006 and be clearly identified and marked with date of manufacture.

6.2 OPERATING AND SERVICE MANUALS AND PARTS LISTS

An operator's manual must be included with each unit upon delivery. A "line sheet" (if applicable) and Equipment Preventative Maintenance Questionnaire (as shown in X6.2 of the Bidder's Evaluation Report) must be with pilot unit upon delivery. In addition, there must be 12 service, shop, or maintenance manuals; ten (10) to be distributed to the Districts and two (2) for the Equipment Division. Also, there must be 14 parts manuals;

THE "WARRANTY AND SERVICE POLICY QUESTIONNAIRE" ATTACHED IN THE BIDDER'S EVALUATION REPORT MUST BE COMPLETED IN ITS ENTIRETY BY THE SUCCESSFUL BIDDER OR MANUFACTURER PRIOR TO DELIVERY OF THE PILOT MODEL. (SEE SECTION X6.5 OF BIDDER'S EVALUATION REPORT).

6.6 EVALUATION COMMITTEE REQUIREMENTS

Detailed component specifications, product literature, component models, required for specification compliance determination by the Evaluation Committee should be provided with each bid. Any information supplied that is contrary to/or conflicting with the specifications and/or attached Bidders Evaluation Report may be sufficient cause for rejection of bid.

6.7 UNSPECIFIED ACCESSORIES & FEATURES

All parts, equipment, accessories, material, design and performance characteristics not specified herein, but which are necessary to provide a complete unit, must be furnished with each unit and required to conform to strength, quality of material, and quality of workmanship to those which are advertised and provided to the market in general by the unit industry.

All parts and accessories advertised and regularly supplied as standard shall be included, except those which would represent duplication of these specified, and except those which, by specification, are not to be furnished. All standard safety features, required by Federal and State Law, shall be included.

7.0 SPECIFICATIONS OF QUOTED UNIT ARE AS FOLLOWS:

- 7.1 Roller(s) shall be equipped with ROPS and FOPS canopy.
- 7.2 Engine shall be manufacturers water/air cooled diesel powered and shall provide a minimum of 28 horsepower and sufficient torque to operate machine and hydraulic system at maximum efficiency.
- 7.3 Steering system shall be of hydraulic, full power, articulated design.
- 7.4 Unit shall be of a low profile design.
- 7.5 Unit weight to be approximately 6000 pounds.
- 7.6 Wheel base to be approximately 68 inches.
- 7.7 Roller(s) shall have dual drum drive with hydrostatic propulsion.
- 7.8 Unit shall be equipped with manufacturers vandalism package.
- 7.9 Unit shall travel 0 to 6 M.P.H. forward and reverse minimum.

- 7.14 Gauges to be illuminated and shall be equipped with visual or audible warning that will advise operator when manufacturer recommended safe operating ranges are exceeded.
 - 7.14.1 Unit shall be provided with hour meter operable from engine operation (not key switch.)
 - 7.14.2 Ignition switch water sealed.
 - 7.14.3 Fuel gauge.
 - 7.14.4 Volt/Amp meter gauge.
 - 7.14.5 Oil pressure gauge.
 - 7.14.6 Engine temperature gauge
 - 7.14.7 Operators station to have manufacturer's fully adjustable isolation mounted seat with seat belt.
 - 7.14.8 OSHA approved back-up alarm shall be provided and installed by manufacturer.
 - 7.14.9 Unit to have a parking brake "on" indicator.
 - 7.14.10 A neutral start safety switch shall be provided.
- 7.15 Water System:
 - 7.15.1 Tank capacity to be 50 gallon approximately.
 - 7.15.2 Water system shall be pressurized.
 - 7.15.3 Water flow must be variable.
 - 7.15.4 Water filter(s) shall be provided in system.
 - 7.15.5 Screened back nozzle type sprayers for drums.
 - 7.15.6 Empty water tank indicator to be provided.
 - 7.15.7 Water pump shall be capable of "Run Dry" situation without damage to pump or components.
 - 7.15.8 Water tank and complete water system shall be constructed of rust proof materials.
 - 7.15.9 Water tank shall have drain plug.

NOTE: Vendor should type Bidder's Evaluation Report

WEST VIRGINIA DEPARTMENT OF TRANSPORTATION
DIVISION OF HIGHWAYS
EQUIPMENT DIVISION

BIDDER'S EVALUATION REPORT

PROCUREMENT SPECIFICATIONS FOR OPEN END CONTRACT
NO. 591-2-K

DOUBLE DRUM VIBRATORY ROLLER/COMPACTOR

NOTE TO BIDDER: Procurement Specification No. 591-2-K, Paragraph 2.0 recommends the completion and submittal of this Report with your bid. Purpose of this Report is to enable the West Virginia Division of Highways Evaluation Committee to make full and fair evaluation of the bid.
FAILURE TO SUBMIT THIS REPORT, COMPLETE IN ITS ENTIRETY, MAY SUBJECT THE BIDDER TO DISQUALIFICATION.

Reference Requisition No.: 707EC008

Bidder's Name: Valley Air Inc.

Address: P.O. Box 6516 Charleston, WV 25362

Telephone Number: (800) 435-9959 or (304) 345-2851

Years Bidder has been registered to do business with the State of West Virginia: 20 YRS.

Years Company has been an authorized dealer for proposed unit: 3 YRS.

X4.2 DELIVERY:

X4.2.1 Delivery date of completed representative unit: 30 Calendar Days After Date of Purchase Agreement

X4.2.2 Delivery date of balance of completed units: 120 Calendar Days After Date of Purchase Agreement

X5.0 AWARD CRITERIA;

X5.1 Prices for unit in quantities of	1-10	<u>30,937.64</u>	per unit
	11-20	<u>30,937.64</u>	per unit
	21 and over	<u>30,937.64</u>	per unit

X6.0 SPECIFICATIONS - GENERAL

X6.1 Manufacturer, model, series, and date of manufacture of proposed unit:

TEREX Model TV1200-12006/2007Is descriptive literature, fully describing proposed unit attached to your bid? YES NO

If not, why? _____

X6.2 Will the required number of service manuals, and complete parts list be delivered to the Equipment Division at Buckhannon upon completion of delivery of total units? YES NOWill the required Equipment Preventive Maintenance Form (Section X6.2 of Bidders Evaluation Report) be provided upon inspection of the pilot unit? YES NO

X6.2
2-10-00

EQUIPMENT PREVENTATIVE MAINTENANCE QUESTIONNAIRE

THIS FORM MUST BE COMPLETED IN ITS ENTIRETY BY SUCCESSFUL BIDDER OR MANUFACTURER'S TECHNICAL REPRESENTATIVE PRIOR TO DELIVERY OF PILOT MODEL TO THE WVDOH.

DESCRIPTION: Double Drum Vibratory Roller MAKE: Terex

MODEL: TV1200-1 YEAR: 2006/2007 PURCHASE AMOUNT: 30,937.64

ENGINE: MAKE: _____ MODEL: _____ FUEL TYPE: _____

HORSEPOWER: _____ CYLINDER: _____ ENGINE SERIAL: _____

COOLING SYSTEM CAPACITY: _____

BELTS: DESCRIPTION: _____ PART NUMBERS: _____

GVW: _____ AXLE CAPACITY: FRONT: _____ REAR: _____

TIRES: FRONT MAKE & SIZE: _____

REAR MAKE & SIZE: _____

DIMENSIONS OF UNIT: LENGTH: _____ WIDTH: _____ LENGTH: _____

VENDOR CONTACT PERSON: Jim Pauley PHONE: (800) 435-9959

PARTS:

BATTERY MAKE: _____ MODEL: _____ CCA: _____

TOP OR SIDE POST: _____ DIMENSIONS: LENGTH _____ WIDTH _____ HEIGHT _____

SPARK PLUGS OR FUEL INJECTORS MAKE: _____ PART # _____

FUEL PUMP OR INJECTION PUMP MAKE: _____ MODEL: _____

ALTERNATOR MAKE: _____ PART #: _____

STARTER MAKE: _____ PART #: _____

TURBO CHARGER MAKE: _____ PART #: _____

TRANS. MAKE: _____ MODEL: _____ AUTO/MANUAL: _____

HYDRAULIC PUMP MAKE: _____ MODEL: _____

FILTERS	MAKE	PART NO.	LUBRICANT	MANUFACTURER TYPE
OIL	_____	_____	ENGINE	_____
AIR INNER	_____	_____	TRANSMISSION	_____
AIR OUTER	_____	_____	POWER STEERING	_____
FUEL PRIMARY	_____	_____	HYDRAULIC	_____
FUEL SECONDARY	_____	_____	DIFFERENTIALS	_____
COOLANT	_____	_____	BRAKE FLUID	_____
HYDRAULIC	_____	_____	COOLANT	_____
OTHER	_____	_____	OTHER	_____

** COMPLETE INFORMATION TO BE PROVIDED UPON RECEIPT OF ORDER

X6.3 TRAINING:

Will training seminar be conducted on Preventive Maintenance, Operator and Mechanic Training
 YES NO

Will you conduct training with each purchase order against this open end contract?
 YES NO

Will training be conducted within 2 working days from the delivery of the pilot unit on the individual purchase order?
 YES NO

If NO, explain time frame _____

Will an Operator's Manual be furnished to the Training Academy? YES NO

X6.4 If you are the successful vendor, will you furnish all training aids, i.e., videos, projectors, required in conducting the training? YES NO

X6.4.1 Will all manuals, booklets, etc. explaining preventive maintenance, operator procedures, and service schedule be delivered with each unit? YES NO
 If NO, explain _____

X6.5 WARRANTY AND SERVICE POLICY

Will the warranty and service you provide comply with all areas as stated in Section 6.5 of specifications
 YES NO

Is warranty literature attached? YES NO

X6.5 WARRANTY AND SERVICE POLICY QUESTIONNAIRE

THIS FORM MUST BE COMPLETED IN ITS ENTIRETY BY THE SUCCESSFUL BIDDER OR MANUFACTURERS TECHNICAL REPRESENTATIVE PRIOR TO DELIVERY OF PILOT MODEL TO THE WVDOH (If additional lines are needed, make copies of form.)

1. Define the terms of the standard warranty. If not offered, so state. (Attach copy)

SEE COPY OF ATTACHED WARRANTY STATEMENT

2. Define warranty service to be performed at DOH facilities and warranty service to be performed at manufacturer's representative facility. List name and location of manufacturer's representative.

NON-INTRUSIVE REPAIRS WILL BE PERFORMED AT WVDOH FACILITY

INTRUSIVE REPAIRS WILL BE PERFORMED AT VALLEY AIR INC.

3. List locations for parts inventories that are within the State of West Virginia. Also, list availability levels, if known.

VALLEY AIR INC. 3000 EDENS FORK RD. CHARLESTON, WV 25312

VALLEY AIR INC. 212 N OHIO AVENUE CLARKSBURG, WV 26301

4. During the term of warranty, list the guarantee discount to manufacturer's published list price for parts that bidder will sell the parts to owner.

A. Terms: Net 30 Manufacturer's published list price less: 0 % discount
 B. Terms: Net 60 Manufacturer's published list price less: 0 % discount
 C. Terms: Net 90 Manufacturer's published list price less: 0 % discount

5. During the term of warranty, will all manufacturers or engineering improvements be submitted to Division of Highways? x YES NO

6. During the term of warranty, list the guaranteed rates charged for repair to the unit.

A. Shop Rate \$ 0 per mechanic hour \$55.00 Hr Non-Warranty

B. Travel Time Charge \$ 0 per mechanic hour \$42.00 Hr Non-Warranty
 (Specify if one-way) _____; port to port _____ Port to Port

C. Mileage Charge \$ 1.50 per vehicle mile
 (Specify if one-way) _____; port to port x

D. Field Mechanic Rate \$ 0 per mechanic hour \$79.00 Hr Non-Warranty

E. Specify period of time that prices are in effect: 9/29/06 thru 9/29/07

F. Surcharge for miscellaneous items: 0 %

X6.6 EVALUATION COMMITTEE REQUIREMENTS

Is all component specifications, product literature, component models provided for Evaluation Committee bid determination? X YES NO

X6.7 Will all parts, equipment, accessories, material, design and performance characteristics not specified herein, but which are necessary to provide a complete unit, be furnished with the unit and conform in strength, quality of material, and quality of workmanship to those which are advertised and provided to the market in general by the unit industry? X YES NO

X6.7.1 Are all parts and accessories adequate and regularly supplied as standard to be included except those which may be duplications of specifications herein, and except these by specification are not to be furnished? X YES NO

X6.7.2 Are all standard safety features that are required by Federal and State statutes of law included? X YES NO

X7.0 SPECIFICATIONS OF THE QUOTED UNIT

The bidder should complete the following schedule in order for the Division to compare the actual bid unit to the specifications. Should the bidder except a requirement, then such exception may be only on the basis that such feature is not offered by the manufacturer. The Division will have the sole discretion as to whether the bidder's substitution meets the requirements of the specifications.

Manufacturer: Terex Model: TV1200-1

X7.1 Are roller(s) equipped with ROPS and FOPS canopy? X YES NO

X7.2 Is engine manufacturer's water/air water cooled diesel/sufficient torque to operate machine/hydraulic system at maximum efficiency? X YES NO
Specify engine horsepower 33HP

X7.3 Is steering of hydraulic, full power, articulated design? X YES NO

X7.4 Is unit a low profile design? X YES NO

X7.5 Unit weight: 6382 pounds Operating Weight

X7.6 Wheel base: 65.94 inches

X7.7 Does unit have dual drum drive with hydrostatic propulsion? X YES NO

X7.8 Does unit have manufacturer's vandalism package? X YES NO

X7.9 Travel speed: Forward 7.2 , Reverse 7.2 mph

X7.10 Engine:

- X7.10.1 Is manufacturer heaviest duty dual fuel filtering system offered? YES NO
- X7.10.2 Has full pressure lubrication with oil filter/by pass system? YES NO
- X7.10.3 Is governor key shut off, wire sealed by manufacturer? YES NO
- X7.10.4 Is cooling system provided with permanent type Dex-Cool extended life (or equal) to a freeze point of -34°? YES NO

X7.11 Brakes:

- X7.11.1 Has hydrostatic propulsion service brake? YES NO
- X7.11.2 Is parking brake spring-applied, hydraulically released on each drum drive? YES NO

X7.12 Drums:

- X7.12.1 Are drums manufacturers heavy duty? YES NO
- X7.12.2 Drum width: 47.24 inches
- X7.12.3 Drum diameter: 27.5 inches
- X7.12.4 Are wiper bars mounted front and rear of each drum? YES NO
- X7.12.5 Are wiper bars self adjusting and spring loaded? YES NO
- X7.12.6 Do wiper bars have replaceable rubber/neoprene drum cleaners? YES NO
- X7.12.7 Are front/rear drums of vibratory compaction type? YES NO
- X7.12.8 Are vibrating parts isolated from rest of roller? YES NO
- X7.12.9 Are vibrating system isolators replaceable? YES NO
- X7.12.10 Will unit be equipped with automatic vibration switch? YES NO

X7.13 Electrical:

- X7.13.1 Does electrical system have manufacturer's heavy duty 12 volt D.C. negative ground? YES NO
- X7.13.2 Has manufacturers recommended heavy duty maintenance free battery? YES NO
- X7.13.3 Has battery CCA approximate 500? CCA: 770 YES NO
- X7.13.4 Alternator: 65 AMP with internal regulator?

- X7.14 Will gauges be illuminated/equipped w/visual or audible warning that will advise operator when Mfg. recommended safe operating ranges are exceeded? X YES NO
- X7.14.1 Is unit provided with hour meter operable from engine operation (not key switch)? X YES NO
- X7.14.2 Is ignition switch water sealed? X YES NO
- X7.14.3 Has fuel gauge? X YES NO
- X7.14.4 Has volt/amp meter gauge as per addendum X YES NO
- X7.14.5 Has oil pressure gauge? as per addendum X YES NO
- X7.14.6 Has engine temperature gauge? as per addendum X YES NO
- X7.14.7 Are seats manufacturers fully adjustable, isolation mounted and with seat belts at operators station? X YES NO
- X7.14.8 Has OSHA approved back-up alarm installed by manufacturer? X YES NO
- X7.14.9 Does unit have a parking brake "on" indicator? X YES NO
- X7.14.10 Is provided with a neutral start safety switch? X YES NO
- X7.15 Water System:
- X7.15.1 Tank capacity: 47.5 gallons
- X7.15.2 Is water system pressurized? X YES NO
- X7.15.3 Is water flow variable? X YES NO
- X7.15.4 Are water filters provided? X YES NO
- X7.15.5 Has screened back nozzle sprayers? X YES NO
- X7.15.6 Is empty tank indicator provided? X YES NO
- X7.15.7 Has water pump capable of "Run Dry" situation without damage to pump or components? X YES NO
- X7.15.8 Is water system of rust-proof material? X YES NO
- X7.15.9 Does water tank have drain plug? X YES NO

X7.16 Lighting:

X7.16.1 Is unit equipped with visible flashers front and rear? YES NO

X7.16.2 Has work lights front and rear? YES NO

X7.16.3 Is strobe light amber color, mounted and model specified? YES NO

X7.17 Are all manufacturers safety decals/features provided? YES NO

X7.18 Is one (1) complete set of replacement filters with unit upon delivery? YES NO

X7.19 Paint:

X7.19.1 Is manufacturer's recommended paint preparation/color provided? YES NO

X7.20 Does proposed unit meet or exceed the "OSHA of 1970"? YES NO

X7.21 Does unit conform to the advertising guidelines? YES NO

X7.22 Preventive Maintenance and Operators Orientation/Training:

X7.22.1 Have you attached a copy of proposed training program along with schedule of course. Will you furnish all training aids? YES NO



State of West Virginia
 Department of Administration
 Purchasing Division
 2019 Washington Street East
 Post Office Box 50130
 Charleston, WV 25305-0130

Request for Quotation

RFQ NUMBER
707EC008

PAGE
1

ADDRESS CORRESPONDENCE TO ATTENTION OF:
JOHN JOHNSTON
304-558-2402

VENDOR

*709054056 304-345-2851
VALLEY AIR INC
PO BOX 6516

CHARLESTON WV 25362

SHIP TO

DIVISION OF HIGHWAYS
EQUIPMENT DIVISION
ROUTE 33
BRUSHY FORK ROAD
BUCKHANNON, WV
26201 **304-472-1750**

DATE PRINTED	TERMS OF SALE	SHIP VIA	F.O.B.	FREIGHT TERMS
09/25/2006	Net 30 Days	Motor Truck	Buckhannon WV	Prepaid

BID OPENING DATE: **10/04/2006** **BID OPENING TIME 01:30PM**

LINE	QUANTITY	UOP	CAT. NO.	ITEM NUMBER	UNIT PRICE	AMOUNT
ADDENDUM NO. 1						
CHANGES TO THE SPECIFICATIONS PER THE ATTACHED.						
BID OPENING DATE AND TIME REMAINS THE SAME.						
NO OTHER CHANGES.						
0001	1	EA		760-66	30,937.64	30,937.64
				DOUBLE DRUM VIBRATORY ROLLER/COMPACTOR		
***** THIS IS THE END OF RFQ 707EC008 ***** TOTAL:						30,937.64

SEE REVERSE SIDE FOR TERMS AND CONDITIONS

SIGNATURE	TELEPHONE	DATE
	(800) 435-9959	10/02/06
TITLE	FEIN	ADDRESS CHANGES TO BE NOTED ABOVE
Sales Representative	55-065-9314-001	

WHEN RESPONDING TO RFQ, INSERT NAME AND ADDRESS IN SPACE ABOVE LABELED 'VENDOR'

ADDENDUM #1
707EC008

OPEN END CONTRACT
DOUBLE DRUM VIBRATORY ROLLER/COMPACTOR

CHANGES TO SPECIFICATIONS:

FROM:

- 4.0 REPRESENTATIVE UNIT FOR TEST (2nd Sentence)
If requested, the time period for testing and evaluation shall be seven (7) calendar days following receipt of the unit.

TO:

- 4.0 REPRESENTATIVE UNIT FOR TEST (2nd Sentence)
If requested, the time period for testing and evaluation shall be seven (7) working days following receipt of the unit.

FROM:

- 4.2 DELIVERY (3rd Paragraph)
A completed pilot model for inspection must be provided within 30 calendar days after the date of the purchase agreement by the successful vendor.

TO:

- 4.2 DELIVERY (3rd Paragraph)
A completed pilot model for inspection should be provided within 45 calendar days after the date of the purchase agreement by the successful vendor.

FROM:

- 7.14 Gauges to be illuminated and shall be equipped with visual or audible warning that will advise operator when manufacturer recommended safe operating ranges are exceeded.

TO:

- 7.14 Gauges to be illuminated and to be equipped with visual or audible warning that will advise operator when manufacturer recommended safe operating ranges are exceeded

FROM:

- 7.14.4 Volt/Amp meter gauge

TO:

- 7.14.4. Volt/Amp meter gauge or light

704EC008

Page 2

FROM:

7.14.5 Oil pressure gauge

TO:

7.14.5 Oil pressure gauge or light

FROM:

7.14.6 Engine temperature gauge

TO:

7.14.6 Engine temperature gauge or light

ADDENDUM #1
707EC008

OPEN END CONTRACT
DOUBLE DRUM VIBRATORY ROLLER/COMPACTOR

CHANGES TO BIDDER'S EVALUATION REPORT:

X4.0 REPRESENTATIVE UNIT FOR TEST -- NO CHANGE REQUIRED

X4.2 DELIVERY OF COMPLETED REPRESENTATIVE UNIT -- NO CHANGE
REQUIRED

X7.14 Gauges -- NO CHANGE REQUIRED

FROM:

X7.14.4 Has volt/amp meter gauge _____ YES _____ NO

TO:

X7.14.4 Has volt/amp meter gauge or light YES _____ NO

FROM:

X7.14.5 Has oil pressure gauge _____ YES _____ NO

TO:

X7.14.5 Has oil pressure gauge or light YES _____ NO

FROM:

X7.14.6 Has engine temperature gauge _____ YES _____ NO

TO:

X7.14.6 Has engine temperature gauge or light YES _____ NO



VALLEY AIR
3000 EDENS FORK ROAD
P. O. BOX 6516
CHARLESTON, WV 25362-0516
PHONE: (304) 345-2851
1-800-435-9959
FAX: (304) 345-2856
www.logancorp.com

RE: RFQ# 707EC008

PROPOSED TRAINING PROGRAM

Valley Air, Inc. will provide an Operator and Service Training Program to be conducted at WVDOH training facility at Buckhannon, WV

Training will include representatives from both Valley Air, Inc. and Terex.



TEREX

Rollers | Tandem & Pedestrian

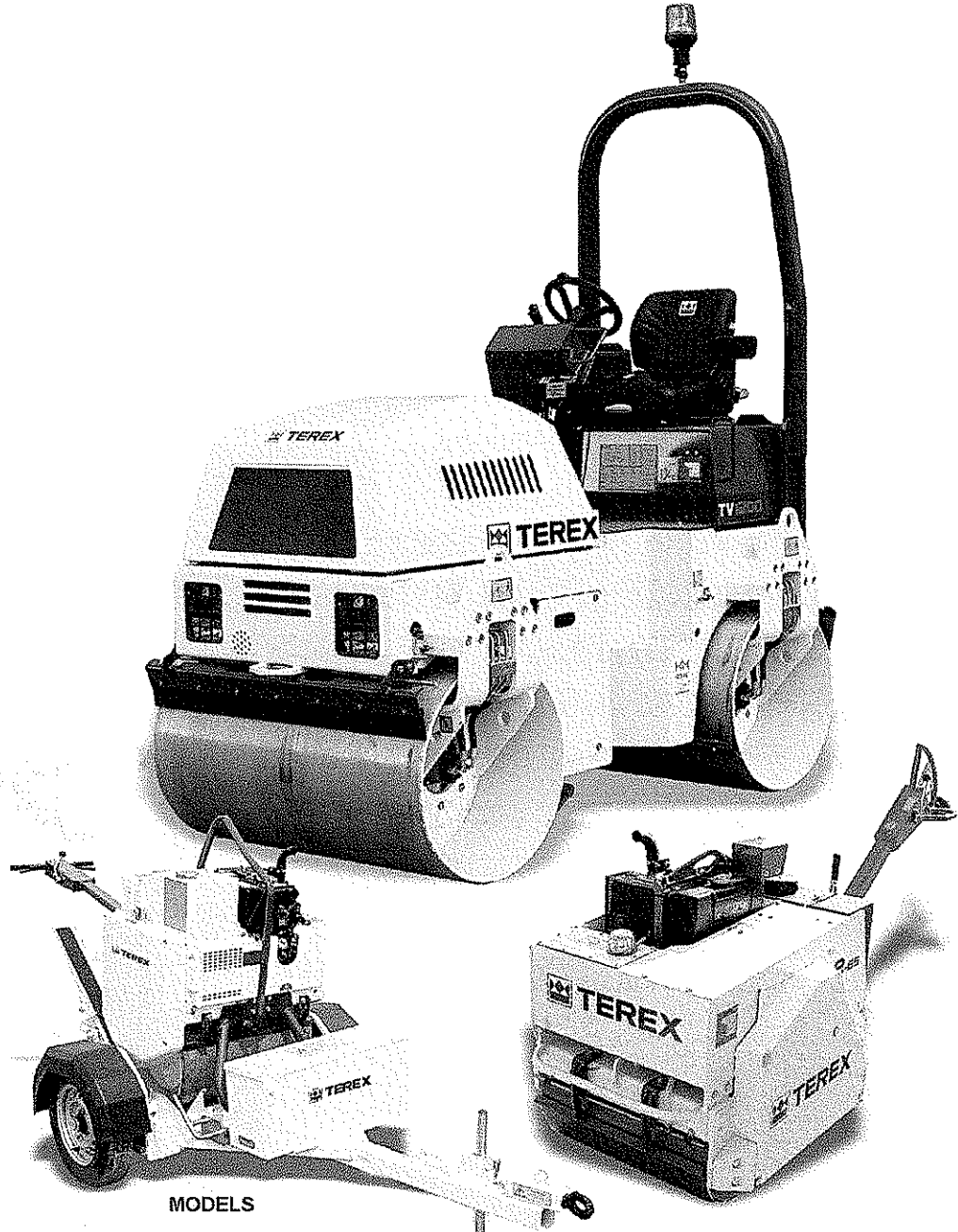

MODELS

1-71

MBR71

2-65

TV800

TV800H

TV1000

TV1200

TV1200H

TV1300

TV1400



TEREX®

TV1000-1 & TV1200-1

Tandem Asphalt Rollers

OPERATING WEIGHT 5,644 / 6,382 lbs
(2,560 / 2,895 kg)

NET ENGINE POWER 33 hp
(24.5 kW)

STATIC LINEAR LOAD 71.7 / 67.5 lbs/in
(12.0 / 13.9 kg/cm)

CENTRIFUGAL FORCE 5,397 / 6,776 lbs
(24.0 / 30.4 kN)

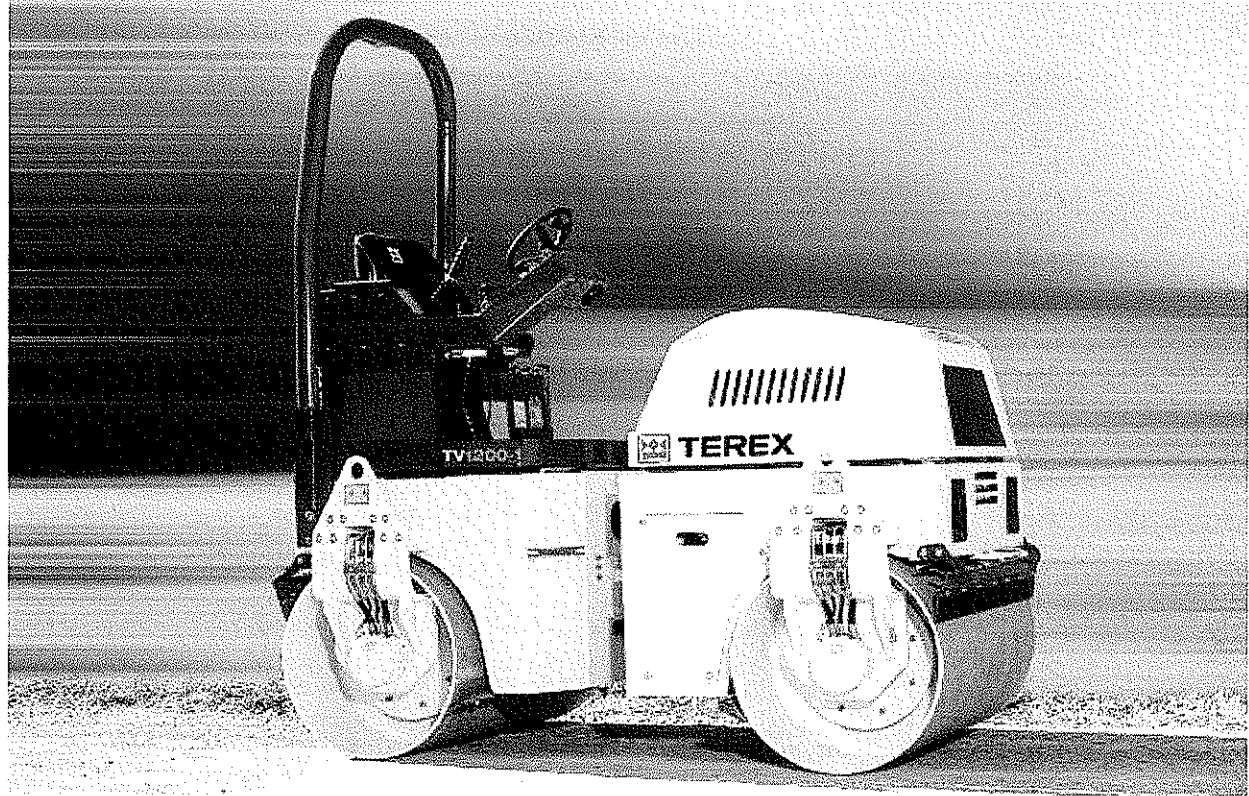

Operating Data, Standard Equipment

	TV1000-1	TV1200-1
Operating weight	5,644 lbs (2,560 kg)	6,382 lbs (2,895 kg)
Basic weight	5,238 lbs (2,376 kg)	5,977 lbs (2,711 kg)
Static linear load	71.7 lbs/in (12.0 kg/cm)	67.5 lbs/in (13.9 kg/cm)
Total length	93.5 in (2,375 mm)	93.5 in (2,375 mm)
Total width	42.12 in (1,070 mm)	50 in (1,270 mm)
Turning radius (inside)	103 in (2,625 mm)	99 in (2,525 mm)
Total height	104.33 in (2,650 mm)	104.33 in (2,650 mm)
Frame articulation degrees	30°	30°
Frame oscillation degrees	15°	15°
Frequency (Hz) VPM	3,120 (51 Hz)	3,120 (51 Hz)
Amplitude	.022 in (0.6 mm)	.022 in (0.6 mm)
Centrifugal Force	5,397 lbs (24.0 kN)	6,776 lbs (30.4 kN)
Gradeability % (with vibration on)	30%	30%
Gradeability % (with vibration off)	40%	40%
Drum thickness	.78 in (20 mm)	.51 in (13 mm)

Tandem Asphalt Rollers

TV1000-1 & TV1200-1

Specifications

Engine	
Manufacturer, model	Kubota, D1703-M
Type	3-cylinder, diesel engine
Power rating at 2,500 rpm	33 hp (24.5 kW)
Cooling system	Air

Electrical System	
Nominal voltage	12 Volt
Battery	770 CCA
Alternator	65 Amp

Hydrostatic Transmission	
Hydrostatic drive. Forward and reverse selected from joystick. Infinitely variable speed control forward and reverse. 0 – 7.2 mph (0 – 11.6 km/h)	

Drive	
Dual radial piston drive motors.	

Brakes	
Service brake: Hydrostatic drive provides dynamic braking.	
Parking brake: Spring applied failsafe	

Steering	
Heavy-duty articulated steering	

Fluid Capacities	
Fuel tank	11.6 gal (44 L)
Hydraulic system (includes tank)	11.6 gal (44 L)
Water tank	47.5 gal (180 L)

Operator's Area	
Open operator's seat with functional design, excellent all-round visibility and user-friendly operator controls.	
Operator's suspension seat with hydraulic cushioning and lap belt; weight, height and longitudinally adjustable.	

Standard Features	
Vandal protection package	
Back-up alarm	
2 scraper bars per drum	
Hydraulic test points	
Electrical diagnostics system (LED lights)	
Tow valve	
12 volt battery disconnect	
Pressure and gravity water	
ROPS	

Dimensions

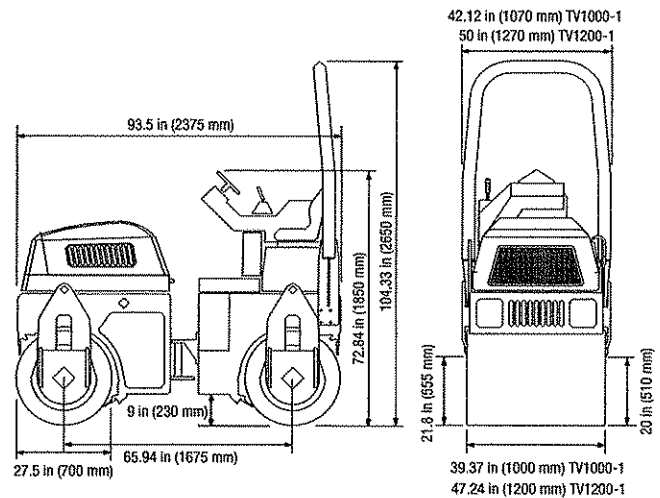

Terex Construction Americas

8800 Rostin Road
Southaven, MS 38671
USA

TEL 662-393-1800
SALES 866-837-3923
PARTS & TECH SUPPORT 888-201-6008
FAX 662-393-1700
EMAIL sales@terexca.com
WEB terexca.com

For more information, product demonstration, or details on purchase, lease and rental plans, please contact your local Terex Distributor.

Effective date: August 15, 2006. For further information, please contact your local distributor or the Terex sales office listed. Product specifications are subject to change without notice or obligation. The photographs and drawings in this brochure are for illustrative purposes only. Refer to the appropriate Operator's Manual for instructions on the proper use of this equipment. Failure to follow the appropriate Operator's Manual when using our equipment or to otherwise act irresponsibly may result in serious injury or death. Prices and specifications subject to change without notice. The only warranty applicable is the standard written warranty applicable to the particular product and sale. Terex makes no other warranty, expressed or implied. Products and services listed may be trademarks, service marks or trade-names of Terex Corporation and/or its subsidiaries in the USA and other countries and all rights are reserved. "Terex" is a Registered Trademark of Terex Corporation in the USA and many other countries. Copyright ©2006 Terex Corporation



TEREX CONSTRUCTION AMERICAS NEW PRODUCT WARRANTY

TEREX CORPORATION d/b/a TEREX CONSTRUCTION AMERICAS, hereafter referred to as TCA, warrants its new Products to be free, under normal use and service, of any defects in manufacture or materials for the period of 12 months from (a) delivery to, and placement into service by the first user or (b) delivery to the first retail purchaser, whichever occurs first; provided that TCA receives written notice of the defect within thirty (30) days of its discovery and Buyer establishes that (i) the equipment has been maintained and operated within the limits of rated and normal usage; and (ii) the defect did not result in any manner from the intentional or negligent action or inaction by Buyer, its agents or employees. If requested by TCA, Buyer must return the defective equipment to a TCA authorized distributor and defective parts to TCA, and if Buyer cannot establish that conditions (i) and (ii) above have been met, then this warranty shall not cover the alleged defect.

The term "Products" shall include only the following equipment sold by TCA: SCL, SKL and SKS model wheel loaders, HR, HML and HS, S1 and S2 model excavators, rollers and backhoes.

Delivery inspection forms are required for warranty validation and processing.

TCA's obligation and liability under this warranty is expressly limited to, at TCA's sole option, repairing or replacing, with new or remanufactured parts or components, any part, which appears to TCA upon inspection to have been defective in manufacture or materials. Such parts shall be provided at no cost to the owner, FOB TCA's parts facility.

This warranty shall be null and void if parts (including wear parts) other than genuine OEM TCA parts are used in the equipment.

Accessories, assemblies and components included in the TCA equipment, which are not manufactured by TCA, are subject to the warranty of their respective manufacturers. Normal maintenance, adjustments, or maintenance/wear parts are not covered by this warranty and are the sole maintenance responsibility of Buyer.

TCA makes no other warranty, express or implied, and makes no warranty of merchantability or fitness for any particular purpose.

No employee or representative is authorized to modify this warranty unless such modification is made in writing and signed by an authorized officer of TCA.

TCA's obligation under this warranty shall not include duty, taxes, or any other charges whatsoever, or any liability for direct, indirect, incidental, or consequential damages.

Improper maintenance, improper use, abuse, improper storage, operation beyond rated capacity, operation after discovery of defective or worn parts, or alteration or repair of the equipment by persons not authorized by TCA shall render this warranty null and void. TCA reserves the right to inspect the installation of the Product and review maintenance procedures to determine if the failure was due to improper maintenance, improper use, abuse, improper storage, operation beyond rated capacity, operation after discovery of defective or worn parts, or alteration or repair of the equipment by persons not authorized by TCA.

TCA reserves the right to make improvements or changes to its Products without incurring any obligation to make such changes or modifications to Products previously sold.

Parts Warranty: TCA warrants the parts ordered from the Parts Department to be free of defect in manufacture or materials for a period of 90 days from date of purchase from TCA.

TRANSFERABILITY OF WARRANTY: The unexpired portion of this warranty may be transferred, provided that (i) the warranty has not been voided or breached by the transfer or prior to transfer, (ii) TCA has received warranty registration for the relevant Product and (iii) the transferee completes and returns to TCA the appropriate warranty transfer documentation which shall be provided upon request. Please contact your local TCA Distributor for additional details if needed.

IN THE EVENT OF ANY BREACH OF THE WARRANTY BY TCA, TCA'S LIABILITY SHALL BE LIMITED EXCLUSIVELY TO THE REMEDIES (AT TCA'S SOLE OPTION) OF REPAIR OR REPLACEMENT OF ANY DEFECTIVE EQUIPMENT COVERED BY THE WARRANTY. IN NO EVENT SHALL TCA, OR ANY SUBSIDIARY, OR DIVISION THEREOF BE LIABLE FOR INCIDENTAL, INDIRECT, CONSEQUENTIAL OR OTHER DAMAGES OR LOSSES RESULTING FROM A BREACH OF WARRANTY INCLUDING, WITHOUT LIMITATION, LABOR COSTS, LOSS OF USE OF OTHER EQUIPMENT, THIRD PARTY REPAIRS, PERSONAL INJURY, EMOTIONAL OR MENTAL DISTRESS, IMPROPER PERFORMANCE OR WORK, PENALTIES OF ANY KIND, LOSS OF SERVICE OF PERSONNEL, OR FAILURE OF EQUIPMENT TO COMPLY WITH ANY FEDERAL, STATE OR LOCAL LAWS.

ITEMS NOT COVERED BY TCA WARRANTY

The following items are NOT covered under the TCA Warranty (the following list is not exhaustive):

1. Items sold by any individual, corporation, partnership or any other organization or legal entity that is not an authorized TCA Distributor.
2. Components which are not manufactured by TCA are not covered by TCA's warranty. Such components are covered only by the warranty that is provided by the manufacturer of such components. Such components include, but are not limited to, engines, electric motors, air compressors, air conditioners, batteries, tires etc.
3. **Replacement of assemblies:** TCA has the option to repair or replace any defective part or assembly. It is TCA's policy to refuse claims for the replacement of a complete assembly that is field repairable by the replacement or repair of defective part(s) within the assembly.
4. **Normal Operational Maintenance Services and Wear Parts:** Maintenance services and wear parts are excluded from warranty claims. Maintenance services not covered include, but are not limited to, such items as: tune-up, lubrication, fuel or hydraulic system cleaning, brake inspection or adjustment, or the replacement of any service items such as filters or brake linings made in connection with normal maintenance services.
5. **Transportation:** Any damage caused by carrier handling is a transportation claim and should be filed immediately with the respective carrier. Travel and mileage costs are not covered under this warranty.
6. **Deterioration:** Work required or parts exposed as the result of age, storage, weathering, lack of use, demonstration use.
7. **Secondary Failures:** Should the Buyer continue to operate a machine after it has been noted that a failure has occurred, TCA will not be responsible under the warranty for resultant damage to other parts due to that continued operation.
8. **Workmanship of Others:** TCA does not accept responsibility for improper installation or labor costs of personnel other than authorized TCA Distributor personnel.
9. **Stop and Go Warranty:** TCA does not recognize "Stop and Go" warranties; after the period of warranty commences, it shall not be tolled for any reason.
10. **Incidental or Consequential Damage:** TCA shall not be liable for any Incidental or Consequential Damages of any kind, including, but not limited to, lost profits, loss of production, increased overhead, loss of business opportunity, delays in production, costs of replacement components and increased costs of operation that may arise from the breach of this warranty. Customer's sole remedy shall be limited to (at TCA's sole option) repair or replacement of the defective part.
11. **Diagnostic Labor:** TCA shall not be responsible for diagnostic labor, travel mileage, travel labor or related travel expenses (such as meals and lodging); overtime or premium labor rates.

THIS WARRANTY IS EXPRESSLY IN LIEU OF AND EXCLUDES ALL OTHER WARRANTIES, EXPRESS OR IMPLIED (INCLUDING THE WARRANTIES OF MERCHANTABILITY AND FITNESS FOR A PARTICULAR PURPOSE) AND ALL OTHER OBLIGATIONS OR LIABILITY ON TCA'S PART. THERE ARE NO WARRANTIES THAT EXTEND BEYOND THE LIMITED WARRANTY CONTAINED HEREIN. TCA neither assumes nor authorizes any other person to assume for TCA any other liability in connection with the sale of TCA's equipment. This warranty shall not apply to any of TCA's equipment or any part thereof which has been subject to misuse, alteration, abuse, negligence, accident, acts of God or sabotage. No action by any party shall operate to extend or revive this limited warranty without the prior written consent of TCA.

TEREX CONSTRUCTION AMERICAS

Southaven, MS 38671 USA

August 2004

AFFIDAVIT

West Virginia Code §5A-3-10a states:

No contract or renewal of any contract may be awarded by the state or any of its political subdivisions to any vendor or prospective vendor when the vendor or prospective vendor or a related party to the vendor or prospective vendor is a debtor and the debt owned is an amount greater than one thousand dollars in the aggregate.

DEFINITIONS:

"Debt" means any assessment, premium, penalty, fine, tax or other amount of money owed to the state or any of its political subdivisions because of a judgment, fine, permit violation, license assessment, defaulted workers' compensation premium, penalty or other assessment presently delinquent or due and required to be paid to the state or any of its political subdivisions, including any interest or additional penalties accrued thereon.

"Debtor" means any individual, corporation, partnership, association, limited liability company or any other form or business association owing a debt to the state or any of its political subdivisions.

"Political subdivision" means any county commission; municipality; county board of education; any instrumentality established by a county or municipality; any separate corporation or instrumentality established by one or more counties or municipalities, as permitted by law; or any public body charged by law with the performance of a government function or whose jurisdiction is coextensive with one or more counties or municipalities.

"Related party" means a party, whether an individual, corporation, partnership, association, limited liability company or any other form or business association or other entity whatsoever, related to any vendor by blood, marriage, ownership or contract through which the party has a relationship of ownership or other interest with the vendor so that the party will actually or by effect receive or control a portion of the benefit, profit or other consideration from performance of a vendor contract with the party receiving an amount that meets or exceeds five percent of the total contract amount.

EXCEPTION:

The prohibition of this section does not apply where a vendor has contested any tax administered pursuant to chapter eleven of this code, workers' compensation premium, permit fee or environmental fee or assessment and the matter has not become final or where the vendor has entered into a payment plan or agreement and the vendor is not in default of any of the provisions of such plan or agreement.

LICENSING:

The vendor must be licensed in accordance with any and all state requirements to do business with the state of West Virginia.

CONFIDENTIALITY:

The vendor agrees that he or she will not disclose to anyone, directly or indirectly, any such personally identifiable information or other confidential information gained from the agency, unless the individual who is the subject of the information consents to the disclosure in writing or the disclosure is made pursuant to the agency's policies, procedures and rules. Vendors should visit www.state.wv.us/admin/purchase/privacy for the Notice of Agency Confidentiality Policies.

Under penalty of law for false swearing (West Virginia Code, §61-5-3), it is hereby certified that the vendor acknowledges the information in this said affidavit and are in compliance with the requirements as stated.

Vendor's Name Valley Air Inc.

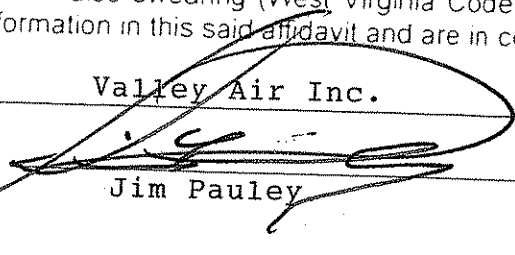
Authorized Signature 

Date: 10/02/06

Jim Pauley