



State of West Virginia
 Department of Administration
 Purchasing Division
 2019 Washington Street East
 Post Office Box 50130
 Charleston, WV 25305-0130

Request for Quotation

RFQ NUMBER
707EC005

PAGE
1

ADDRESS CORRESPONDENCE TO ATTENTION OF:
JOHN JOHNSTON
304-558-2402

VENDOR

*709051756 304-346-5301
 WV TRACTOR COMPANY
 PO BOX 473
 CHARLESTON WV 25322

SHIP TO

DIVISION OF HIGHWAYS
 EQUIPMENT DIVISION
 ROUTE 33
 BRUSHY FORK ROAD
 BUCKHANNON, WV
 26201 304-472-1750

DATE PRINTED 08/01/2006	TERMS OF SALE Net 30 Days	SHIP VIA Truck	F.O.B. Buckhannon	FREIGHT TERMS Prepaid
BID OPENING DATE: 09/13/2006		BID OPENING TIME 01:30PM		

LINE	QUANTITY	UOP	CAT NO	ITEM NUMBER	UNIT PRICE	AMOUNT
0001	1	EA		760-47 HYUNDAI HL730TM-7	\$74,491	
<p>4 WHEEL DRIVE, RUBBER TIRED ENDLOADER</p> <p>OPEN END CONTRACT</p> <p>TO PROVIDE 4 WHEEL DRIVE, RUBBER TIRED ENDLOADER, AS DESCRIBED IN ATTACHED PROCUREMENT SPECIFICATION 353-1-R.</p> <p>THERE WILL BE A MANDATORY PRE-BID CONFERENCE AT THE STATE CAPITOL COMPLEX, BUILDING 15, CONFERENCE ROOM, AT 1:00 PM ON 8/31/06. FAILURE TO ATTEND THE PRE-BID CONFERENCE WILL RESULT IN BID DISQUALIFICATION.</p> <p>QUESTIONS: WRITTEN QUESTIONS WILL BE ACCEPTED THROUGH CLOSE OF BUSINESS (5:00PM EST) ON WEDNESDAY 8/23/06.</p> <p>SEND YOUR QUESTIONS TO: PURCHASING DIVISION ATTENTION JOHN JOHNSTON 2019 WASHINGTON ST. E. CHARLESTON, WV. 25305</p> <p>QUESTIONS MAY BE SENT VIA FAX, E-MAIL, OR REGULAR MAIL. E-MAIL: JJOHNSTON@WVADMIN.GOV FAX: 304-558-4115</p> <p>IT IS THE VENDORS RESPONSIBILITY TO VERIFY THAT THEIR QUESTIONS HAVE BEEN RECEIVED BY CALLING 304-558-2402.</p> <p>EXHIBIT 2</p> <p>LIFE OF CONTRACT: THIS CONTRACT BECOMES EFFECTIVE ON AND EXTENDS FOR A PERIOD OF ONE (1) YEAR OR UNTIL SUCH "REASONABLE TIME" THEREAFTER AS IS</p>						

SEE REVERSE SIDE FOR TERMS AND CONDITIONS

SIGNATURE <i>John Johnston</i>	TELEPHONE 346-5301	DATE 9-19-06
TITLE President	FEIN 550621655	ADDRESS CHANGES TO BE NOTED ABOVE

WHEN RESPONDING TO RFQ, INSERT NAME AND ADDRESS IN SPACE ABOVE LABELED 'VENDOR'



State of West Virginia
 Department of Administration
 Purchasing Division
 2019 Washington Street East
 Post Office Box 50130
 Charleston, WV 25305-0130

Request for Quotation

RFQ NUMBER
707EC005

PAGE
1

ADDRESS CORRESPONDENCE TO ATTENTION OF
JOHN JOHNSTON 304-558-2402

VENDOR

*709051756 304-346-5301
 WV TRACTOR COMPANY
 PO BOX 473
 CHARLESTON WV 25322

SHIP TO

DIVISION OF HIGHWAYS
 EQUIPMENT DIVISION
 ROUTE 33
 BRUSHY FORK ROAD
 BUCKHANNON, WV
 26201 304-472-1750

DATE PRINTED	TERMS OF SALE	SHIP VIA	F.O.B.	FREIGHT TERMS
09/05/2006	Net 30 Days	Truck	Buckhannon	Prepaid
BID OPENING DATE: 09/20/2006		BID OPENING TIME 01:30PM		

LINE	QUANTITY	UOP	CAT NO.	ITEM NUMBER	UNIT PRICE	AMOUNT
				ADDENDUM NO. 1		
				CHANGES TO THE SPECIFICATIONS PER THE ATTACHED		
				BID OPENING DATE AND TIME CHANGED		
				FROM: 09-13-06 AT 1:30 P.M.		
				TO: 09-20-06 AT 1:30 P.M.		
				NO OTHER CHANGES		
0001	1	EA		HYUNDAI HL730TM-7 760-47	\$74,491	
				4 WHEEL DRIVE, RUBBER TIRE ENDLOADER		
***** THIS IS THE END OF RFQ 707EC005 ***** TOTAL:						

SEE REVERSE SIDE FOR TERMS AND CONDITIONS

SIGNATURE	TELEPHONE	DATE
<i>Tracy Gray</i>	346-5301	9-19-06
TITLE	FEIN	ADDRESS CHANGES TO BE NOTED ABOVE
President	550621655	

WHEN RESPONDING TO RFQ, INSERT NAME AND ADDRESS IN SPACE ABOVE LABELED 'VENDOR'



State of West Virginia
 Department of Administration
 Purchasing Division
 2019 Washington Street East
 Post Office Box 50130
 Charleston, WV 25305-0130

Request for Quotation

RFQ NUMBER
707EC005

PAGE
2

ADDRESS CORRESPONDENCE TO ATTENTION OF:
JOHN JOHNSTON 304-558-2402

VENDOR	*709051756	304-346-5301
	WV TRACTOR COMPANY	
	PO BOX 473	
	CHARLESTON WV 25322	

SHIP TO	DIVISION OF HIGHWAYS	
	EQUIPMENT DIVISION	
	ROUTE 33	
	BRUSHY FORK ROAD	
	BUCKHANNON, WV 26201	304-472-1750

DATE PRINTED	TERMS OF SALE	SHIP VIA	F.O.B.	FREIGHT TERMS
08/01/2006				

BID OPENING DATE: 09/13/2006 BID OPENING TIME 01:30PM

LINE	QUANTITY	UOP	CAT NO.	ITEM NUMBER	UNIT PRICE	AMOUNT
<p>NECESSARY TO OBTAIN A NEW CONTRACT OR RENEW THE ORIGINAL CONTRACT. THE "REASONABLE TIME" PERIOD SHALL NOT EXCEED TWELVE (12) MONTHS. DURING THIS "REASONABLE TIME" THE VENDOR MAY TERMINATE THIS CONTRACT FOR ANY REASON UPON GIVING THE DIRECTOR OF PURCHASING THIRTY (30) DAYS WRITTEN NOTICE.</p> <p>UNLESS SPECIFIC PROVISIONS ARE STIPULATED IN THIS CONTRACT DOCUMENT, THE TERMS, CONDITIONS, AND PRICING SET HEREIN ARE FIRM FOR THE LIFE OF THE CONTRACT.</p> <p>RENEWAL: THIS CONTRACT MAY BE RENEWED UPON THE MUTUAL WRITTEN CONSENT OF THE SPENDING UNIT AND VENDOR, SUBMITTED TO THE DIRECTOR OF PURCHASING THIRTY (30) DAYS PRIOR TO THE EXPIRATION DATE. SUCH RENEWAL SHALL BE IN ACCORDANCE WITH THE TERMS AND CONDITIONS OF THE ORIGINAL CONTRACT AND SHALL BE LIMITED TO TWO (2) ONE (1) YEAR PERIODS.</p> <p>CANCELLATION: THE DIRECTOR OF PURCHASING RESERVES THE RIGHT TO CANCEL THIS CONTRACT IMMEDIATELY UPON WRITTEN NOTICE TO THE VENDOR IF THE COMMODITIES AND/OR SERVICES SUPPLIED ARE OF AN INFERIOR QUALITY OR DO NOT CONFORM WITH THE SPECIFICATIONS OF THE BID AND CONTRACT HEREIN</p> <p>OPEN MARKET CLAUSE: THE DIRECTOR OF PURCHASING MAY AUTHORIZE A SPENDING UNIT TO PURCHASE ON THE OPEN MARKET, WITHOUT THE FILING OF A REQUISITION OR COST ESTIMATE, ITEMS SPECIFIED ON THIS CONTRACT FOR IMMEDIATE DELIVERY IN EMERGENCIES DUE TO UNFORESEEN CAUSES (INCLUDING BUT NOT LIMITED TO DELAYS IN TRANSPORTATION OR AN UNANTICIPATED INCREASE IN THE VOLUME OF WORK).</p> <p>QUANTITIES: QUANTITIES LISTED IN THE REQUISITION ARE APPROXIMATIONS ONLY, BASED ON ESTIMATES SUPPLIES BY THE STATE SPENDING UNIT. IT IS UNDERSTOOD AND AGREED THAT</p>						

SEE REVERSE SIDE FOR TERMS AND CONDITIONS

SIGNATURE	TELEPHONE	DATE
TITLE	FEIN	ADDRESS CHANGES TO BE NOTED ABOVE

WHEN RESPONDING TO RFQ, INSERT NAME AND ADDRESS IN SPACE ABOVE LABELED 'VENDOR'



State of West Virginia
 Department of Administration
 Purchasing Division
 2019 Washington Street East
 Post Office Box 50130
 Charleston, WV 25305-0130

Request for Quotation

RFQ NUMBER
707EC005

PAGE
3

ADDRESS CORRESPONDENCE TO ATTENTION OF:
JOHN JOHNSTON 304-558-2402

VENDOR

*709051756 304-346-5301
 WV TRACTOR COMPANY
 PO BOX 473
 CHARLESTON WV 25322

SHIP TO

DIVISION OF HIGHWAYS
 EQUIPMENT DIVISION
 ROUTE 33
 BRUSHY FORK ROAD
 BUCKHANNON, WV
 26201 304-472-1750

DATE PRINTED	TERMS OF SALE	SHIP VIA	F.O.B.	FREIGHT TERMS
08/01/2006				

BID OPENING DATE: 09/13/2006 BID OPENING TIME 01:30PM

LINE	QUANTITY	UOP	CAT NO.	ITEM NUMBER	UNIT PRICE	AMOUNT
<p>THE CONTRACT SHALL COVER THE QUANTITIES ACTUALLY ORDERED FOR DELIVERY DURING THE TERM OF CONTRACT, WHETHER MORE OR LESS THAN THE QUANTITIES SHOWN.</p> <p>ORDERING PROCEDURE: SPENDING UNIT(S) SHALL ISSUE A WRITTEN EQUIPMENT CONTRACT ORDER (FORM NUMBER WV-35) FOR COMMODITIES COVERED BY THIS CONTRACT. THE ORIGINAL WV-35 MUST BE SENT TO THE PURCHASING DIVISION OF THE DEPARTMENT OF ADMINISTRATION. AFTER APPROVAL AND ENCUMBRANCE, ONE COPY OF THE PURCHASE ORDER WILL BE RETURNED TO THE SPENDING UNIT AND ONE COPY FORWARDED TO THE VENDOR AS AUTHORIZATION FOR SHIPMENT. NO ORDER IS VALID UNLESS APPROVED AND ENCUMBERED BY THE PURCHASING DIVISION.</p> <p>BANKRUPTCY: IN THE EVENT THE VENDOR/CONTRACTOR FILES FOR BANKRUPTCY PROTECTION, THIS CONTRACT IS AUTOMATICALLY NULL AND VOID, AND IS TERMINATED WITHOUT FURTHER ORDER.</p> <p>REV. 9/98</p> <p>EXHIBIT 6</p> <p>PRICE ADJUSTMENT PROVISION: THE STATE OF WEST VIRGINIA WILL CONSIDER BIDS THAT CONTAIN PROVISIONS FOR PRICE ADJUSTMENTS PRIOR TO THE ORIGINAL EXPIRATION OF THE CONTRACT, PROVIDED THAT SUCH PRICE ADJUSTMENT COVERS BOTH UPWARD AND DOWNWARD MOVEMENT OF THE COMMODITY PRICE, AND THAT ADJUSTMENT IS BASED ON THE "PASS THROUGH" INCREASE OR DECREASE OF RAW MATERIALS AND/OR LABOR, WHICH MAKE UP ALL OR A SUBSTANTIAL PART OF A PRODUCT. ADJUSTMENTS ARE TO BE BASED UPON AN ACTUAL DOLLAR FIGURE, NOT A PERCENTAGE. ALL PRICE ADJUSTMENT REQUESTS MUST BE SUBSTANTIATED IN</p>						

SEE REVERSE SIDE FOR TERMS AND CONDITIONS

SIGNATURE	TELEPHONE	DATE
TITLE	FEIN	ADDRESS CHANGES TO BE NOTED ABOVE

WHEN RESPONDING TO RFQ, INSERT NAME AND ADDRESS IN SPACE ABOVE LABELED 'VENDOR'



State of West Virginia
 Department of Administration
 Purchasing Division
 2019 Washington Street East
 Post Office Box 50130
 Charleston, WV 25305-0130

Request for Quotation

RFQ NUMBER
707EC005

PAGE
4

ADDRESS CORRESPONDENCE TO ATTENTION OF
JOHN JOHNSTON 304-558-2402

VENDOR

*709051756 304-346-5301
 WV TRACTOR COMPANY
 PO BOX 473
 CHARLESTON WV 25322

SHIP TO

DIVISION OF HIGHWAYS
 EQUIPMENT DIVISION
 ROUTE 33
 BRUSHY FORK ROAD
 BUCKHANNON, WV
 26201 304-472-1750

DATE PRINTED	TERMS OF SALE	SHIP VIA	F.O.B.	FREIGHT TERMS
08/01/2006				

BID OPENING DATE: **09/13/2006** BID OPENING TIME: **01:30PM**

LINE	QUANTITY	UOP	CAT NO	ITEM NUMBER	UNIT PRICE	AMOUNT
<p>A MANNER ACCEPTABLE TO THE DIRECTOR PURCHASING, E.G. GOVERNMENTAL BENCH MARKS, GENERAL MARKET INCREASE, PUBLISHED PRICE LISTS. SUCH REQUESTS FOR AND INCREASE SHOULD BE RECEIVED IN WRITING BY THE DIRECTOR OF PURCHASING AT LEAST 30 DAYS IN ADVANCE OF THE EFFECTIVE DATE OF THE INCREASE. ANY TIME THE VENDOR REQUESTS A PRICE ADJUSTMENT, THE PURCHASING DIVISION MAY EITHER ACCEPT THE PRICE ADJUSTMENT AND AMEND THE CONTRACT ACCORDINGLY OR REJECT THE ADJUSTMENT IN ITS ENTIRETY AND CANCEL THE CONTRACT.</p> <p style="text-align: center;">VENDOR PREFERENCE CERTIFICATE</p> <p>CERTIFICATION AND APPLICATION* IS HEREBY MADE FOR PREFERENCE IN ACCORDANCE WITH WEST VIRGINIA CODE, 5A-3-37 (DOES NOT APPLY TO CONSTRUCTION CONTRACTS).</p> <p>A. APPLICATION IS MADE FOR 2.5% PREFERENCE FOR THE REASON CHECKED:</p> <p>() BIDDER IS AN INDIVIDUAL RESIDENT VENDOR AND HAS RESIDED CONTINUOUSLY IN WEST VIRGINIA FOR FOUR (4) YEARS IMMEDIATELY PRECEDING THE DATE OF THIS CERTIFICATION; OR</p> <p>(xx) BIDDER IS A PARTNERSHIP, ASSOCIATION OR CORPORATION RESIDENT VENDOR AND HAS MAINTAINED ITS HEAD-QUARTERS OR PRINCIPAL PLACE OF BUSINESS CONTINUOUSLY IN WEST VIRGINIA FOR FOUR (4) YEARS IMMEDIATELY PRECEDING THE DATE OF THIS CERTIFICATION; OR 80% OF THE OWNERSHIP INTEREST OF BIDDER IS HELD BY ANOTHER INDIVIDUAL, PARTNERSHIP, ASSOCIATION OR CORPORATION RESIDENT VENDOR WHO HAS MAINTAINED ITS HEADQUARTERS OR PRINCIPAL PLACE OF BUSINESS CONTINUOUSLY IN WEST VIRGINIA FOR FOUR (4) YEARS IMMEDIATELY PRECEDING THE DATE OF THIS CERTIFICATION; OR</p>						

SEE REVERSE SIDE FOR TERMS AND CONDITIONS

SIGNATURE	TELEPHONE	DATE
TITLE	FEIN	ADDRESS CHANGES TO BE NOTED ABOVE

WHEN RESPONDING TO RFQ, INSERT NAME AND ADDRESS IN SPACE ABOVE LABELED 'VENDOR'



State of West Virginia
 Department of Administration
 Purchasing Division
 2019 Washington Street East
 Post Office Box 50130
 Charleston, WV 25305-0130

Request for Quotation

RFQ NUMBER
707EC005

PAGE
5

ADDRESS CORRESPONDENCE TO ATTENTION OF:
JOHN JOHNSTON 304-558-2402

VENDOR

*709051756 304-346-5301
 WV TRACTOR COMPANY
 PO BOX 473
 CHARLESTON WV 25322

SHIP TO

DIVISION OF HIGHWAYS
 EQUIPMENT DIVISION
 ROUTE 33
 BRUSHY FORK ROAD
 BUCKHANNON, WV
 26201 304-472-1750

DATE PRINTED	TERMS OF SALE	SHIP VIA	F.O.B	FREIGHT TERMS
08/01/2006				

BID OPENING DATE: 09/13/2006 BID OPENING TIME 01:30PM

LINE	QUANTITY	UOP	CAT NO.	ITEM NUMBER	UNIT PRICE	AMOUNT
<p>() BIDDER IS A CORPORATION NONRESIDENT VENDOR WHICH HAS AN AFFILIATE OR SUBSIDIARY WHICH EMPLOYS A MINIMUM OF ONE HUNDRED STATE RESIDENTS AND WHICH HAS MAINTAINED ITS HEADQUARTERS OR PRINCIPAL PLACE OF BUSINESS WITHIN WEST VIRGINIA CONTINUOUSLY FOR THE FOUR (4) YEARS IMMEDIATELY PRECEDING THE DATE OF THIS CERTIFICATION.</p> <p>B. APPLICATION IS MADE FOR 2.5% PREFERENCE FOR THE REASON CHECKED:</p> <p>(xx) BIDDER IS A RESIDENT VENDOR WHO CERTIFIES THAT, DURING THE LIFE OF THE CONTRACT, ON AVERAGE AT LEAST 75% OF THE EMPLOYEES WORKING ON THE PROJECT BEING BID ARE RESIDENTS OF WEST VIRGINIA WHO HAVE RESIDED IN THE STATE CONTINUOUSLY FOR THE TWO YEARS IMMEDIATELY PRECEDING SUBMISSION OF THIS BID; OR () BIDDER IS A NONRESIDENT VENDOR EMPLOYING A MINIMUM OF ONE HUNDRED STATE RESIDENTS OR IS A NONRESIDENT VENDOR WITH AN AFFILIATE OR SUBSIDIARY WHICH MAINTAINS ITS HEADQUARTERS OR PRINCIPAL PLACE OF BUSINESS WITHIN WEST VIRGINIA EMPLOYING A MINIMUM OF ONE HUNDRED STATE RESIDENTS WHO CERTIFIES THAT, DURING THE LIFE OF THE CONTRACT, ON AVERAGE AT LEAST 75% OF THE EMPLOYEES OR BIDDERS' AFFILIATE'S OR SUBSIDIARY'S EMPLOYEES ARE RESIDENTS OF WEST VIRGINIA WHO HAVE RESIDED IN THE STATE CONTINUOUSLY FOR THE TWO YEARS IMMEDIATELY PRECEDING SUBMISSION OF THIS BID.</p> <p>BIDDER UNDERSTANDS IF THE SECRETARY OF TAX & REVENUE DETERMINES THAT A BIDDER RECEIVING PREFERENCE HAS FAILED TO CONTINUE TO MEET THE REQUIREMENTS FOR SUCH PREFERENCE, THE SECRETARY MAY ORDER THE DIRECTOR OF PURCHASING TO: (A) RESCIND THE CONTRACT OR PURCHASE</p>						

SEE REVERSE SIDE FOR TERMS AND CONDITIONS

SIGNATURE	TELEPHONE	DATE
TITLE	FEIN	ADDRESS CHANGES TO BE NOTED ABOVE

WHEN RESPONDING TO RFQ, INSERT NAME AND ADDRESS IN SPACE ABOVE LABELED 'VENDOR'



State of West Virginia
 Department of Administration
 Purchasing Division
 2019 Washington Street East
 Post Office Box 50130
 Charleston, WV 25305-0130

Request for Quotation

RFQ NUMBER
707EC005

PAGE
6

ADDRESS CORRESPONDENCE TO ATTENTION OF
JOHN JOHNSTON
304-558-2402

VENDOR

*709051756 304-346-5301
WV TRACTOR COMPANY
PO BOX 473

CHARLESTON WV 25322

SHIP TO

DIVISION OF HIGHWAYS
EQUIPMENT DIVISION
ROUTE 33
BRUSHY FORK ROAD
BUCKHANNON, WV
26201 **304-472-1750**

DATE PRINTED 08/01/2006	TERMS OF SALE	SHIP VIA	F.O.B.	FREIGHT TERMS
-----------------------------------	---------------	----------	--------	---------------

BID OPENING DATE: **09/13/2006** BID OPENING TIME **01:30PM**

LINE	QUANTITY	UOP	CAT NO.	ITEM NUMBER	UNIT PRICE	AMOUNT
<p>ORDER ISSUED; OR (B) ASSESS A PENALTY AGAINST SUCH BIDDER IN AN AMOUNT NOT TO EXCEED 5% OF THE BID AMOUNT AND THAT SUCH PENALTY WILL BE PAID TO THE CONTRACTING AGENCY OR DEDUCTED FROM ANY UNPAID BALANCE ON THE CONTRACT OR PURCHASE ORDER.</p> <p>BY SUBMISSION OF THIS CERTIFICATE, BIDDER AGREES TO DISCLOSE ANY REASONABLY REQUESTED INFORMATION TO THE PURCHASING DIVISION AND AUTHORIZES THE DEPARTMENT OF TAX AND REVENUE TO DISCLOSE TO THE DIRECTOR OF PURCHASING APPROPRIATE INFORMATION VERIFYING THAT BIDDER HAS PAID THE REQUIRED BUSINESS TAXES, PROVIDED THAT SUCH INFORMATION DOES NOT CONTAIN THE AMOUNTS OF TAXES PAID NOR ANY OTHER INFORMATION DEEMED BY THE TAX COMMISSIONER TO BE CONFIDENTIAL.</p> <p>UNDER PENALTY OF LAW FOR FALSE SWEARING (WEST VIRGINIA CODE 61-5-3), BIDDER HEREBY CERTIFIES THAT THIS CERTIFICATE IS TRUE AND ACCURATE IN ALL RESPECTS; AND THAT IF A CONTRACT IS ISSUED TO BIDDER AND IF ANYTHING CONTAINED WITHIN THIS CERTIFICATE CHANGES DURING THE TERM OF THE CONTRACT, BIDDER WILL NOTIFY THE PURCHASING DIVISION IN WRITING IMMEDIATELY.</p> <p style="text-align: right;">West Virginia Tractor Company</p> <p>BIDDER: -----</p> <p style="text-align: center;">9-19-06</p> <p>DATE: -----</p> <p>SIGNED: ----- <i>James Tracy</i> -----</p> <p style="text-align: center;">President</p> <p>TITLE: -----</p>						

SEE REVERSE SIDE FOR TERMS AND CONDITIONS			
SIGNATURE	TELEPHONE	DATE	
TITLE	FEIN	ADDRESS CHANGES TO BE NOTED ABOVE	

WHEN RESPONDING TO RFQ, INSERT NAME AND ADDRESS IN SPACE ABOVE LABELED 'VENDOR'



State of West Virginia
 Department of Administration
 Purchasing Division
 2019 Washington Street East
 Post Office Box 50130
 Charleston, WV 25305-0130

Request for Quotation

RFQ NUMBER
707EC005

PAGE
7

ADDRESS CORRESPONDENCE TO ATTENTION OF:
JOHN JOHNSTON 304-558-2402

VENDOR

*709051756 304-346-5301
 WV TRACTOR COMPANY
 PO BOX 473

 CHARLESTON WV 25322

SHIP TO

DIVISION OF HIGHWAYS
 EQUIPMENT DIVISION
 ROUTE 33
 BRUSHY FORK ROAD
 BUCKHANNON, WV
 26201 304-472-1750

DATE PRINTED	TERMS OF SALE	SHIP VIA	F.O.B.	FREIGHT TERMS
08/01/2006				

BID OPENING DATE: **09/13/2006** **BID OPENING TIME 01:30PM**

LINE	QUANTITY	UOP	CAT NO.	ITEM NUMBER	UNIT PRICE	AMOUNT
<p>* CHECK ANY COMBINATION OF PREFERENCE IN EITHER "A" OR "B", OR BOTH "A" AND "B" WHICH YOU ARE ENTITLED TO RECEIVE. YOU MAY REQUEST UP TO THE MAXIMUM 5% PREFERENCE FOR BOTH "A" AND "B". (REV. 12/00)</p> <p style="text-align: center;">NOTICE</p> <p>A SIGNED BID MUST BE SUBMITTED TO:</p> <p style="text-align: center;">DEPARTMENT OF ADMINISTRATION PURCHASING DIVISION BUILDING 15 2019 WASHINGTON STREET, EAST CHARLESTON, WV 25305-0130</p> <p>THE BID SHOULD CONTAIN THIS INFORMATION ON THE FACE OF THE ENVELOPE OR THE BID MAY NOT BE CONSIDERED:</p> <p>SEALED BID</p> <p>BUYER: 33</p> <p>RFQ. NO.: 707EC005</p> <p>BID OPENING DATE AND TIME</p> <p>PLEASE PROVIDE A FAX NUMBER IN CASE IT IS NECESSARY TO CONTACT YOU REGARDING YOUR BID:</p>						

SEE REVERSE SIDE FOR TERMS AND CONDITIONS

SIGNATURE	TELEPHONE	DATE
TITLE	FEIN	ADDRESS CHANGES TO BE NOTED ABOVE

WHEN RESPONDING TO RFQ, INSERT NAME AND ADDRESS IN SPACE ABOVE LABELED 'VENDOR'



State of West Virginia
 Department of Administration
 Purchasing Division
 2019 Washington Street East
 Post Office Box 50130
 Charleston, WV 25305-0130

Request for Quotation

RFQ NUMBER
707EC005

PAGE
8

ADDRESS CORRESPONDENCE TO ATTENTION OF:
JOHN JOHNSTON 304-558-2402

VENDOR
*709051756 304-346-5301 WV TRACTOR COMPANY PO BOX 473 CHARLESTON WV 25322

SHIP TO
DIVISION OF HIGHWAYS EQUIPMENT DIVISION ROUTE 33 BRUSHY FORK ROAD BUCKHANNON, WV 26201 304-472-1750

DATE PRINTED	TERMS OF SALE	SHIP VIA	F.O.B	FREIGHT TERMS
08/01/2006				

BID OPENING DATE: **09/13/2006** **BID OPENING TIME 01:30PM**

LINE	QUANTITY	UOP	CAT NO.	ITEM NUMBER	UNIT PRICE	AMOUNT
				346-5305		
				CONTACT PERSON (PLEASE PRINT CLEARLY):		
				Gary W. Grady		
***** THIS IS THE END OF RFQ 707EC005 ***** TOTAL:						_____

SEE REVERSE SIDE FOR TERMS AND CONDITIONS

SIGNATURE	TELEPHONE	DATE
TITLE	FEIN	ADDRESS CHANGES TO BE NOTED ABOVE

WHEN RESPONDING TO RFQ, INSERT NAME AND ADDRESS IN SPACE ABOVE LABELED 'VENDOR'

WEST VIRGINIA DEPARTMENT OF TRANSPORTATION
DIVISION OF HIGHWAYS
EQUIPMENT DIVISION

BIDDER'S EVALUATION REPORT

PROCUREMENT SPECIFICATIONS FOR OPEN END CONTRACT
NO. 353-1-R

4 WHEEL DRIVE, RUBBER TIRED, ENDLOADER

NOTE TO BIDDER: Procurement Specification No. 353-1-R, Paragraph 2.0 recommends the completion and submittal of this Report with your bid Purpose of this Report is to enable the West Virginia Division of Highways Evaluation Committee to make full and fair evaluation of the bid.
FAILURE TO SUBMIT THIS REPORT, COMPLETE IN ITS ENTIRETY, MAY SUBJECT THE BIDDER TO DISQUALIFICATION.

Reference Requisition No : 707EC005

Bidder's Name: West Virginia Tractor Company

Address: P.O. Box 473 Charleston, WV 25322

Telephone Number: 346-5301

Years Bidder has been registered to do business with the State of West Virginia: 24 YRS

Years Company has been an authorized dealer for proposed unit: 8 YRS

X4.2 DELIVERY:

X4.2.1 Delivery date of completed representative unit: 90-100 Calendar Days After Date of Purchase Agreement

X4.2.2 Delivery date of balance of completed units: 90-120 Calendar Days After Date of Purchase Agreement

X5.0 AWARD CRITERIA;

X5.1	Prices for endloaders in quantities of	1-10	\$ 74,491	per unit
		11-20	<u>\$ 74,491</u>	per unit
		21-30	<u>\$ 74,491</u>	per unit
		31 and over	<u>\$ 74,491</u>	per unit

X6.0 SPECIFICATIONS - GENERAL

X6.1 Manufacturer, model, series, and date of manufacture of proposed unit:

Hyundai HL730TM-7 2007 and later as ordered
 Is descriptive literature, fully describing proposed unit attached to your bid? YES NO

If not, why? _____

X6.2 Will the required number of service manuals, and complete parts list be delivered to the Equipment Division at Buckhannon upon completion of delivery of total units? YES NO

Will the required Equipment Preventive Maintenance Form (Section X6.2 of Bidders Evaluation Report) be provided upon inspection of the pilot unit? YES NO

X62
2-10-00

EQUIPMENT PREVENTATIVE MAINTENANCE QUESTIONNAIRE

THIS FORM MUST BE COMPLETED IN ITS ENTIRETY BY SUCCESSFUL BIDDER OR MANUFACTURER'S TECHNICAL REPRESENTATIVE PRIOR TO DELIVERY OF PILOT MODEL TO THE WVDOH

DESCRIPTION: _____ MAKE: _____

MODEL: _____ YEAR: _____ PURCHASE AMOUNT: _____

ENGINE: MAKE: _____ MODEL: _____ FUEL TYPE: _____

HORSEPOWER: _____ CYLINDER: _____ ENGINE SERIAL: _____

COOLING SYSTEM CAPACITY: _____

BELTS: DESCRIPTION: _____ PART NUMBERS: _____

GVW: _____ AXLE CAPACITY: FRONT: _____ REAR: _____

TIRES: FRONT MAKE & SIZE: _____

REAR MAKE & SIZE: _____

DIMENSIONS OF UNIT: LENGTH: _____ WIDTH: _____ LENGTH: _____

VENDOR CONTACT PERSON: _____ PHONE: _____

PARTS:

BATTERY MAKE: _____ MODEL: _____ CCA: _____

TOP OR SIDE POST: _____ DIMENSIONS: LENGTH _____ WIDTH _____ HEIGHT _____

SPARK PLUGS OR FUEL INJECTORS MAKE: _____ PART # _____

FUEL PUMP OR INJECTION PUMP MAKE: _____ MODEL: _____

ALTERNATOR MAKE: _____ PART #: _____

STARTER MAKE: _____ PART #: _____

TURBO CHARGER MAKE: _____ PART #: _____

TRANS. MAKE: _____ MODEL: _____ AUTO/MANUAL: _____

HYDRAULIC PUMP MAKE: _____ MODEL: _____

FILTERS MAKE PART NO. LUBRICANT MANUFACTURER TYPE

OIL _____ ENGINE _____

AIR INNER _____ TRANSMISSION _____

AIR OUTER _____ POWER STEERING _____

FUEL PRIMARY _____ HYDRAULIC _____

FUEL SECONDARY _____ DIFFERENTIALS _____

COOLANT _____ BRAKE FLUID _____

HYDRAULIC _____ COOLANT _____

OTHER _____ OTHER _____

X6.3 TRAINING:

Will training seminar be conducted on Preventive Maintenance, Operator and Mechanic Training YES NO

Will you conduct training with each purchase order against this open end contract? YES NO

Will training be conducted within 2 working days from the delivery of the pilot unit on the individual purchase order? YES NO

If NO, explain time frame _____

Will an Operator's Manual be furnished to the Training Academy? YES NO

X6.4 If you are the successful vendor, will you furnish all training aids, i.e., videos, projectors, required in conducting the training? YES NO

X6.4.1 Will all manuals, booklets, etc. explaining preventive maintenance, operator procedures, and service schedule be delivered with each unit? YES NO

If NO, explain _____

X6.5 WARRANTY AND SERVICE POLICY

Will the warranty and service you provide comply with all areas as stated in Section 6.5 of specifications YES NO

Is warranty literature attached? YES NO

X6.5 WARRANTY AND SERVICE POLICY QUESTIONNAIRE

THIS FORM MUST BE COMPLETED IN ITS ENTIRETY BY THE SUCCESSFUL BIDDER OR MANUFACTURERS TECHNICAL REPRESENTATIVE PRIOR TO DELIVERY OF PILOT MODEL TO THE WVDOH (If additional lines are needed, make copies of form.)

1. Define the terms of the standard warranty. If not offered, so state. (Attach copy)
 Standard Hyundai warranty statement is attached.

One year, 1500 hours.

2. Define warranty service to be performed at DOH facilities and warranty service to be performed at manufacturer's representative facility. List name and location of manufacturer's representative.

Most work under warranty can be performed at West Virginia Tractor Company in Charleston. Some Cummins engine warranty may be performed by Cummins Cumberland.

3. List locations for parts inventories that are within the State of West Virginia. Also, list availability levels, if known.

West Virginia Tractor Company in Charleston is the source for Hyundai parts and most Cummins engine parts. Cummins Cumberland in So. Charleston and Fairmont can supply most Cummins parts.

4. During the term of warranty, list the guarantee discount to manufacturer's published list price for parts that bidder will sell the parts to owner.

- A. Terms: Net 30 Manufacturer's published list price less: - % discount
- B. Terms: Net 60 Manufacturer's published list price less: - % discount
- C. Terms: Net 90 Manufacturer's published list price less: - % discount

5. During the term of warranty, will all manufacturers or engineering improvements be submitted to Division of Highways? x YES NO

6. During the term of warranty, list the guaranteed rates charged for repair to the unit.

A. Shop Rate \$ 60.00 per mechanic hour

B. Travel Time Charge \$ 60.00 per mechanic hour
 (Specify if one-way) _____; port to port x

C. Mileage Charge \$ 1.25 per vehicle mile
 (Specify if one-way) _____; port to port x

D. Field Mechanic Rate \$ 60.00 per mechanic hour

E. Specify period of time that prices are in effect: During warranty period

F. Surcharge for miscellaneous items: Holidays and overtime 150%

X6.6 EVALUATION COMMITTEE REQUIREMENTS

Is all component specifications, product literature, component models provided for Evaluation Committee bid determination? YES NO

X6.7 Will all parts, equipment, accessories, material, design and performance characteristics not specified herein, but which are necessary to provide a complete unit, be furnished with the unit and conform in strength, quality of material, and quality of workmanship to those which are advertised and provided to the market in general by the unit industry? YES NO

X6.7.1 Are all parts and accessories adequate and regularly supplied as standard to be included except those which may be duplications of specifications herein, and except these by specification are not to be furnished? YES NO

X6.7.2 Are all standard safety features that are required by Federal and State statutes of law included? YES NO

X7.0 SPECIFICATIONS OF THE QUOTED UNIT

The bidder should complete the following schedule in order for the Division to compare the actual bid unit to the specifications. Should the bidder except a requirement, then such exception may be only on the basis that such feature is not offered by the manufacturer. The Division will have the sole discretion as to whether the bidder's substitution meets the requirements of the specifications.

Manufacturer: Hyundai Model: HL730TM-7

X8.0 Endloader Specification:

X8.1 Operating weight: 22,050 pounds (exclusive of tire ballast)

X8.1.1 Breakout force: 22,240 pounds

X8.2 Overall length (bucket lowered): 23 foot

X8.3 Does loader have articulated frame and full hydraulic power steering? YES NO

X8.3.1 Tipping load straight: 14,640 pounds

- X8.4 Overall height: 10' 3" to top of cab
- X8.4.1 Dumping clearance at maximum height and 45° dump angle: 110 inches
- X8.5 Are units provided with a quick coupler system for interchangeability of attachments, controlled from operator station YES NO
- X8.6 Do machine(s) have vandalism package/keyed alike? YES NO
- X8.7 Are daily services done from ground level? YES NO
- X8.8 Engine:
- X8.8.1 Is engine manufacturers water cooled diesel powered providing 125 HP and torque to operate machine and hydraulic system at maximum efficiency? YES NO
Specify HP: 125 gross and 119 net
- X8.8.2 Is unit equipped with manufacturer's standard governor with key shut off, wire sealed by Manufacturer? YES NO
- X8.8.3 Engine equipped with an engine block water heating element (1500-2000 watt)? YES NO
- X8.8.4 Does heating element have male plug easily accessible, 110 volt AC? YES NO
- X8.9 Engine Lubrication:
- X8.9.1 Has full pressure lubrication with oil filter and oil by-pass system? YES NO
- X8.9.2 Is engine equipped with oil cooler? YES NO
- X8.10 Cooling System:
- X8.10.1 Is cooling system of manufacturers maximum to allow full capability of operation for all seasons? YES NO
- X8.10.2 Cooling system supplied with Dex-Cool or equal extended life anti freeze to -34°F? YES NO
- X8.10.3 Is coolant filter provided if recommended manufacturer for this application? YES NO

X8.11 Air Induction System:

X8.11.1 Is dry type (2 stage) dual element air cleaner with pre-cleaner provided?
 YES NO

X8.11.2 Does unit have dash mounted air filter restriction indicator that is visible when service is required ?
 YES NO

X8.12 Exhaust System:

X8.12.1 Is complete exhaust system manufacturers standard for unit specified?
 YES NO

X8.12.2 Is exhaust pipe rain proof?
 YES NO

X8.13 Electrical System:

X8.13.1 Is unit provided with manufacturers noise suppression wiring?
 YES NO

X8.13.2 Is system 12 volts/24 volts negative ground YES NO

X8.13.3 Are heavy duty CCA battery(s) provided? (2) YES NO
 CCA 850 reserve capacity 160+

X8.14 Charging System:

X8.14.1 Alternator AMPS: 70 with internal regulator? YES NO

X8.15 Engine Fuel System:

X8.15.1 Is fuel capacity at least 12 working hours YES NO

X8.15.2 Is unit provided with a fuel/water separator? YES NO

X8.15.3 Is dual stage fuel filtering provided? YES NO

X8.16 Transmission:

X8.16.1 Is transmission full power shift with torque converter capable of "on the Go" shifting in all ranges? YES NO

Does it have full automatic feature with on-board diagnostic capabilities and kickdown controls YES NO

X8.16.2 Is torque converter capable of handling maximum power output of engine? YES NO

X8.16.3 Number of forward speeds 4 Number of reverse speeds 3 ?

Top forward ground speed: 23 ~~MP~~ MPH

X8.16.4 Is neutral start switch provided for safety purposes? YES NO

X8.17 Differential:

X8.17.1 Is front and rear differential manufacturers conventional type? YES NO

X8.18 Axles:

X8.18.1 Is front axle fixed? YES NO

X8.18.2 Oscillation of rear axle: \pm 13 degrees 26 total

X8.19 Brakes:

X8.19.1 Is Manufacturers recommended emergency braking system provided? YES NO

X8.19.2 Is emergency brake independent of service brake? YES NO

X8.19.3 Are service brakes powered assisted hydraulic actuated? YES NO

X8.19.4 Are service brakes wet disk type? YES NO

X8.20 Hydraulic System:

X8.20.1 Does unit provide hydraulic lift, lower, dump, roll back and float YES NO

Does unit have third spool auxiliary valve and cab controller YES NO

- X8.20.2 Are hydraulic cylinders double action chrome plated piston type? YES NO
- X8.20.3 Is hydraulic oil cooler provided if recommended by manufacturer? YES NO
- X8.20.4 Is sight glass provided for daily service checks? YES NO
- X8.20.5 Hydraulic system relief pressure: 2,990 P.S.I.
- X8.20.6 Is Manufacturers standard hydraulic filtering system provided? YES NO
- X8.21 Tires and Wheels:
- X8.21.1 Are wheels manufacturers recommended size for unit bid? YES NO
Specify size 14 X 25
- X8.21.2 Are tires grader/loader type tubeless radials front and rear? YES NO
Specify size: 17.5X25 R
- X8.21.3 Overall tire width (outside left to outside right): 7 feet 10 inches
- X8.22 Cab and related accessories:
- X8.22.1 Is cab OSHA approved ROPS? YES NO
- X8.22.2 Is cab insulated and pressurized? YES NO
- X8.22.3 Is cab equipped with heater, defroster, air conditioning installed by the manufacturer? YES NO
- X8.22.4 Is cab equipped with wipers and washers front and rear? YES NO
- X8.22.5 Is Manufacturers tinted safety glass at all locations? YES NO
- X8.22.6 Are left and right rear view mirrors and in cab rear view mirror provided? YES NO
- X8.22.7 Does cab have one (1) lockable entry door? YES NO
- X8.22.8 Are doors hinged at rear to provide front to back opening YES NO

- X8.22.9 Is unit provided with non-skid steps and hand holds YES NO
- X8.22.10 Is seat cloth type with scotchguard or equal and with adjustable seat belt YES NO
- X8.22.11 Is seat equipped with adjustable arm rests? YES NO
- X8.22.12 Does seat provide height and weight adjustments? YES NO
- X8.22.13 Is unit equipped with adjustable tilt and telescoping steering wheel for easier operator control? YES NO
- X8.22.14 Are fenders provided front and rear? YES NO
- X8.22.15 Is fire extinguisher provided and mounted on unit? YES NO
- X8.22.16 Is AM/FM radio provided and installed in unit? YES NO

X8.23 Lighting System:

- X8.23.1 Is unit equipped with two (2) hi/low halogen beam front lights for tramming and working? YES NO
- X8.23.2 Does unit have four (4) work lights; two (2) front/two (2) rear cab mounted work lights YES NO
- X8.23.3 Does unit have flash/turn signals (front and rear), stoplights, and taillights? YES NO
- X8.23.4 Does unit have console and dome lighting? YES NO
- X8.23.5 Is unit equipped with low profile high intensity strobe light mounted at top rear of cab as specified YES NO

If NO, explain _____

- X8.23.6 Is unit equipped with audible OSHA approved reverse alarm? YES NO
- X8.23.7 Is articulation locking bar and pin provided? YES NO

X8.24 Unit Instrumentation:

- X8.24.1 Tachometer? YES NO

- X8.24.2 Speedometer? YES NO
- X8.24.3 Does hour meter operate from engine operation? YES NO
- X8.24.4 Fuel gauge? YES NO
- X8.24.5 Ammeter/ or volt meter? YES NO
- X8.24.6 Does coolant temperature indicator have audible buzzer or visual warning light?
 YES NO
- X8.24.7 Does engine oil pressure indicator have audible buzzer or visual warning light?
 YES NO
- X8.24.8 Does unit have transmission oil temperature indicator? YES NO
- X8.24.9 Does unit have transmission oil pressure indicator? YES NO
- X8.24.10 All features considered to be standard equipment not addressed above:
Centralized lubrication fittings, remote drain ports,
centralized electric controllers and fuse box,
centralized control switches and computerized monitoring.
- X8.24.11 Will unit be delivered to WV DOH with manufacturer's safety decals and features intact?
 YES NO
- X8.24.12 Is one (1) complete set of replacement filters for each unit provided?
 YES NO
- X8.25 Bucket:
- X8.25.1 Bucket capacity struck: 1.8 Cu Yd Heaped capacity: 2.1 Cu Yd
- X8.25.2 Bucket width: 94 inches
- X8.25.3 Bucket roll back 50 degrees at ground level and dump at full height
50 degrees
- X8.25.4 Does unit have automatic return to work leveler for bucket and attachments
 YES NO
- X8.25.5 Are replaceable cutting edge and bottom wear strips provided YES NO

- X8.25.6 Is cutting edge welded to bucket and bolt on replaceable cutting edge mounted under it? YES NO
- X8.25.7 Digging depth below horizontal (bucket level): 3.7 inches
- X8.26 Forks:
- X8.26.1 Are forks heavy duty steel construction? YES NO
- X8.26.2 Is carriage of heavy duty steel construction? YES NO
- X8.26.3 Carriage size: 3/4 inch side plates and 60 inches wide?
- X8.26.4 Tines/Forks: 6 inches wide and 48 inches long
- X8.26.5 Tines/Forks: 2 inches thick at heel and forged solid steel
 YES NO
- X8.26.6 Tines/Forks mounted on 2.5 inches diameter round bar
Adjustable laterally 60 inches
- X8.27 Material Handling Boom:
- X8.27.1 Is material handling boom of heavy duty construction with hook?
 YES NO
- X8.27.2 Boom has 3 locking sections Boom reach: 13 feet 7"
- X8.28 Paint:
- X8.28.1 Is endloader painted Federal Standard White 595A (NO. 17875)?
 YES NO
- X8.28.2 Will detail/decorative stripes be provided and installed on unit by successful bidder?
 YES NO
- X8.28.3 Are stripe(s) width 4 inches as specified? YES NO
- X8.28.4 Does striping method and striping material meet required specifications quoted in sections 8.28.4; 8.28.5; and 8.28.6?
 YES NO
- If NO, explain _____

- X8.28.7 Describe color and type of material of upper stripe:

 dark blue Reflexite high intensity reflective

- X8.28.8 Describe color and type of material of lower stripe:
 light gold Reflexite high intensity reflective

- 8.28.9 Will bidder consult WV DOH on proposed striping? YES NO
- X8.28.10 Has bidder attached paint plan (chips/samples/striping details) to compliance form? YES NO
- If no will samples be submitted? YES NO
- X8.28.11 Describe manufacturers paint procedure as specified in sections 8.30.11; 8.30.12; and 8.30.13
 Metal surface cleaned, degrease, primed and painted

 with high quality machinery finish

- X8.28.14 Is white paint specified applied over top of manufacturer's standard color?
 YES NO
- X8.28.15 Are areas of distinct color(s) (e.g. safety reason) be painted as they normally would?
 YES NO
- X8.29 Does proposed unit meet or exceed the "OSHA of 1970" and/or subsequent changes?
 YES NO
- X8.30 Does unit conform to the advertising guidelines? YES NO
- X8.31 Preventive Maintenance and Operators Orientation/Training:
- X8.31.1 Have you attached a copy of proposed training program. Attach schedule describing course offered with a brief explanation of each subject with the time required for each class. Do not attach instruction material or manuals. Will you furnish all training aids; i.e. videos, projectors, etc., required in conducting the training?
 YES NO

AFFIDAVIT

West Virginia Code §5A-3-10a states:

No contract or renewal of any contract may be awarded by the state or any of its political subdivisions to any vendor or prospective vendor when the vendor or prospective vendor or a related party to the vendor or prospective vendor is a debtor and the debt owned is an amount greater than one thousand dollars in the aggregate.

DEFINITIONS:

"Debt" means any assessment, premium, penalty, fine, tax or other amount of money owed to the state or any of its political subdivisions because of a judgment, fine, permit violation, license assessment, defaulted workers' compensation premium, penalty or other assessment presently delinquent or due and required to be paid to the state or any of its political subdivisions, including any interest or additional penalties accrued thereon.

"Debtor" means any individual, corporation, partnership, association, limited liability company or any other form or business association owing a debt to the state or any of its political subdivisions.

"Political subdivision" means any county commission; municipality; county board of education; any instrumentality established by a county or municipality; any separate corporation or instrumentality established by one or more counties or municipalities as permitted by law; or any public body charged by law with the performance of a government function or whose jurisdiction is coextensive with one or more counties or municipalities.

"Related party" means a party, whether an individual, corporation, partnership, association, limited liability company or any other form or business association or other entity whatsoever related to any vendor by blood, marriage, ownership or contract through which the party has a relationship of ownership or other interest with the vendor so that the party will actually or by effect receive or control a portion of the benefit, profit or other consideration from performance of a vendor contract with the party receiving an amount that meets or exceeds five percent of the total contract amount.

EXCEPTION:

The prohibition of this section does not apply where a vendor has contested any tax administered pursuant to chapter eleven of this code, workers' compensation premium, permit fee or environmental fee or assessment and the matter has not become final or where the vendor has entered into a payment plan or agreement and the vendor is not in default of any of the provisions of such plan or agreement.

LICENSING:

The vendor must be licensed in accordance with any and all state requirements to do business with the state of West Virginia.

CONFIDENTIALITY:

The vendor agrees that he or she will not disclose to anyone, directly or indirectly, any such personally identifiable information or other confidential information gained from the agency, unless the individual who is the subject of the information consents to the disclosure in writing or the disclosure is made pursuant to the agency's policies, procedures and rules. Vendors should visit www.state.wv.us/admin/purchase/privacy for the Notice of Agency Confidentiality Policies.

Under penalty of law for false swearing (West Virginia Code §61-5-3), it is hereby certified that the vendor acknowledges the information in this said affidavit and are in compliance with the requirements as stated.

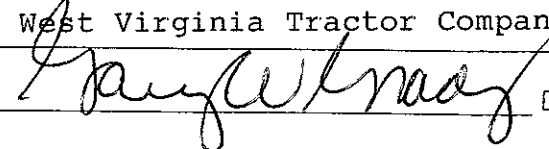
Vendor's Name: West Virginia Tractor Company
Authorized Signature:  Date: 9-19-06

WEST VIRGINIA TRACTOR COMPANY

COMPLIANCE WITH WEST VIRGINIA PURCHASING RULES

As required by law and West Virginia Department of Administration, Purchasing Division Legislative Rule 148 CSR 1, West Virginia Tractor Company is licensed and in good standing with any and all state and local laws and requirements, including the West Virginia Secretary of State's office, the West Virginia Tax Department, the West Virginia Insurance Commission, or any other state agencies or political subdivisions, including the West Virginia Division of Motor Vehicles as a trailer dealer (DTR-1594) and as a new vehicle dealer (D-43).

West Virginia Tractor Company does not discriminate against any employee or applicant for employment because of race, religion, color, sex, handicap, or national origin.

HYUNDAI

CONSTRUCTION EQUIPMENT

Standard Warranty

Hyundai Construction Equipment U.S.A., Inc. (HCE) warrants hydraulic excavators and wheel loaders manufactured and completely assembled by it (products) to be free from defects in material workmanship for a period of three hundred and sixty five (365) calendar days or one thousand and five hundred (1,500) hours of operation as registered on the service meter of such products, whichever period comes first, from the date of delivery of the initial user and subject to the following conditions:

1. This sole remedy under the above warranty, or in any action whether based upon warranty, contract, negligence or strict product liability or otherwise, is limited to the repair or replacement at HCE's option of any defective parts or equipment, transportation prepaid, FOB point of manufacture. Such parts shall be repaired or replaced at no additional cost to the user, and HCE shall pay at the rate established in its published service policy then in effect, the cost of labor reasonably necessary to install any repaired or replacement parts provided under this warranty.
2. This warranty does not apply to:
 - (a) Component parts or accessories of products not manufactured by HCE and which carry the warranty of the manufacturer thereof;
 - (b) Normal maintenance (such as engine tune-up) or to normal maintenance parts (such as filters, cables, bulbs and fuses);
 - (c) Products which have been changed or modified without the prior written consent of HCE;
 - (d) Products which have been operated, maintained or stored in any other manner than prescribed by HCE;
 - (e) Any products improperly repaired by anyone other than an HCE distributor or authorized facility;
 - (f) Products used with attachments not made by HCE; and
 - (g) Products operated beyond their rated capacity;
3. This warranty is exclusive and HCE disclaims all other warranties, express or implied, including without limitation, implied warranties or merchantability or fitness for a particular purpose.
4. In no event shall HCE be liable for incidental, consequential, statutory or exemplary damages including without limitation lost profits, loss of business opportunity, loss of use of the equipment, loss relating to property other than the equipment, or other economic losses.

JRB Product Specifications Construction Utility Forks Manual and Hydraulic

- Carriage widths available from 60" to 120".
- Tine lengths from 48" to 96".
- Manually adjustable tines or hydraulically actuated* tines for side-to-side adjustment from cab.
- Hydraulic side shift and rotation available upon request.
- Construction Utility Forks available as pin-on or with JRB Quick Coupler system.
- Heavy duty design for construction use. Tine static load capacities rated beyond loader lift capabilities.

*Loader 3rdfunction hydraulics required

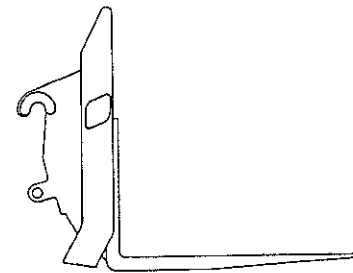
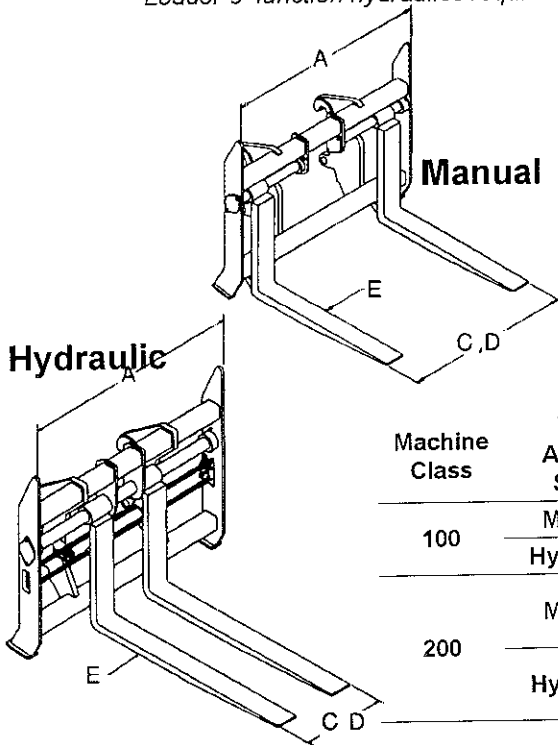

Fork shown with JRB Quick Coupler Adapters

Machine Class	Tine Adjust. Style	"A" Frame Width	"B" Frame Height	"C" Max. Tine Spacing	"D" Min. Tine Spacing	"E" Tine Size	"F" Load Cap. @ 24" Ctr.
100	Manual	61.00	48.00	59.00	10.00	2 x 4	8,400#
	Hydraulic	61.00	48.00	59.00	10.00		
200	Manual	63.75	52.00	60.00	28.25	2 x 6	12,600#
		96.50	52.00	92.75	37.50		
	Hydraulic	63.50	52.00	58.00	24.00		
		97.50	52.00	92.00	40.50		
300 500	Manual	63.75	52.00	60.00	28.25	2.5 x 6	19,700#
		96.50	52.00	92.75	37.50		
	Hydraulic	63.50	52.00	58.00	24.00		
		97.50	52.00	92.00	40.50		
600	Manual	108.00	60.50	103.00	28.00	3 x 7	33,250
	Hydraulic	98.00	53.50	92.00	46.50		
700 800	Manual	108.00	63.12	103.00	38.00	3.5 x 8	51,700#
	Hydraulic	108.00	63.12	103.00	62.00		
900	Manual	108.00	63.12	103.00	40.00	4 x 8	67,500#
	Hydraulic	108.00	63.12	103.00	64.00		

S P E C I F I C A T I O N S

JRB Product Specifications

Extendable Boom

- High strength tubular steel construction.
- Excellent for long reach material handling applications involving lifting, loading and positioning.
- Most efficient attachment for handling large diameter precast pipe.
- All Booms manually extendable.
- An efficient time-saving attachment for any job site.
- Extendable Boom available as pin-on or with JRB Quick Coupler system.

S P E C I F I C A T I O N S

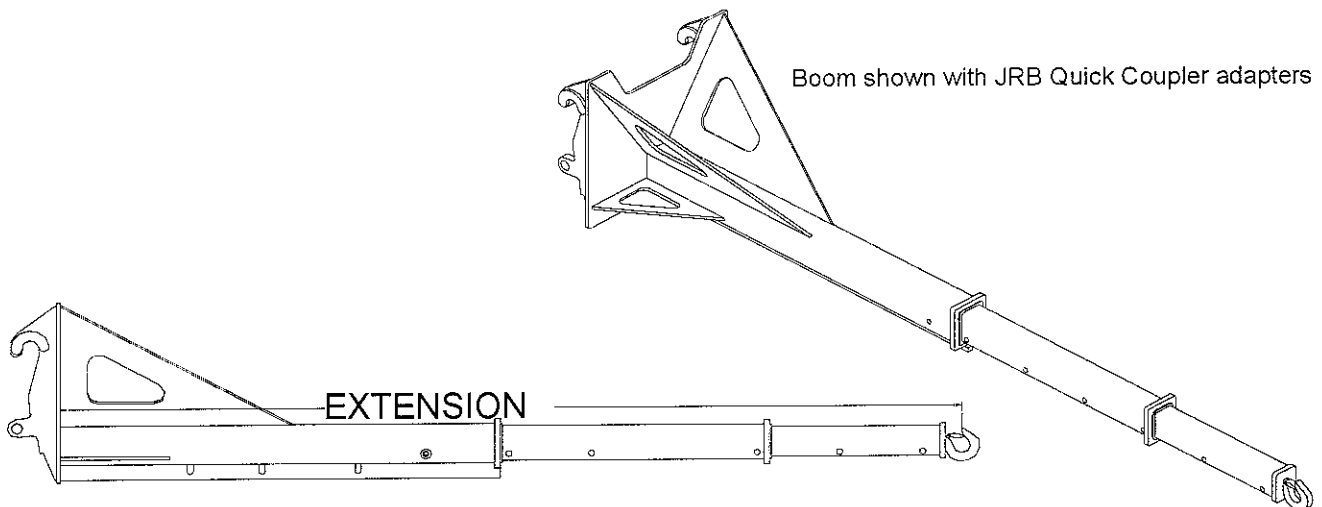

Part Number	Description	Full Extension	Mid Extension	Full Retraction	Weight
100SB6	1 Section - 6' Extension	-	-	-	610#
100SB8	1 Section - 8' Extension	-	-	-	745#
200EB	3 Section - 13' 7" Extension	13' - 7"	11' - 1"	7' - 4"	1,170#
300EB	3 Section - 13' 7" Extension	13' - 7"	11' - 1"	7' - 4"	1,170#
500EB	3 Section - 13' 7" Extension	13' - 7"	11' - 1"	7' - 4"	1,170#
600EB	3 Section - 13' 7" Extension	13' - 7"	11' - 1"	7' - 4"	1,270#
700EB	2 Section - 12' 0" Extension	12' - 0"	-	8' - 3"	1,400#
800EB	2 Section - 12' 0" Extension	12' - 0"	-	8' - 3"	1,400#