



State of West Virginia  
 Department of Administration  
 Purchasing Division  
 2019 Washington Street East  
 Post Office Box 50130  
 Charleston, WV 25305-0130

# Request for Quotation

RFQ NUMBER
707EC004

PAGE
1

ADDRESS CORRESPONDENCE TO ATTENTION OF:
JOHN JOHNSTON 304-558-2402

**VENDOR**

\*709054056      304-345-2851  
 VALLEY AIR INC  
 PO BOX 6516  
 CHARLESTON WV 25362

**SHIP TO**

DIVISION OF HIGHWAYS  
 EQUIPMENT DIVISION  
 ROUTE 33  
 BRUSHY FORK ROAD  
 BUCKHANNON, WV  
 26201      304-472-1750

DATE PRINTED	TERMS OF SALE	SHIP VIA	F.O.B.	FREIGHT TERMS
07/27/2006	Net 30 Days	Motor Truck	Buckhannon, WV	Prepaid
BID OPENING DATE: 09/06/2006		BID OPENING TIME 01:30PM		

LINE	QUANTITY	UOP	CAT NO.	ITEM NUMBER	UNIT PRICE	AMOUNT
0001	1	EA		025-50		15,596.00
<p>185 CFM AIR COMPRESSOR/PORTABLE            Sullair 210HDPQ-JD            OPEN END CONTRACT</p> <p>TO PROVIDE 185 CFM AIR COMPRESSOR/PORTABLE AS DESCRIBED IN ATTACHED PROCUREMENT SPECIFICATION 612-3-K.</p> <p>THERE WILL BE A MANDATORY PRE-BID CONFERENCE AT THE STATE CAPITOL COMPLEX, BUILDING 15, CONFERENCE ROOM, AT 1:00 PM ON 8/24/06. FAILURE TO ATTEND THE PRE-BID CONFERENCE WILL RESULT IN BID DISQUALIFICATION.</p> <p>QUESTIONS: WRITTEN QUESTIONS WILL BE ACCEPTED THROUGH CLOSE OF BUSINESS (5:00PM EST) ON WEDNESDAY, 8/16/06.</p> <p>SEND YOUR QUESTIONS TO: PURCHASING DIVISION            ATTENTION JOHN JOHNSTON            2019 WASHINGTON STREET E.            CHARLESTON, WV. 25305</p> <p>QUESTIONS MAY BE SENT VIA FAX, E-MAIL, OR REGULAR MAIL            E-MAIL: JJOHNSTON@WVADMIN.GOV            FAX: 304-558-2402</p> <p>IT IS THE VENDORS RESPONSIBILITY TO VERIFY THAT THEIR QUESTIONS HAVE BEEN RECEIVED BY CALLING 304-558-2402.</p> <p>EXHIBIT 2</p> <p>LIFE OF CONTRACT: THIS CONTRACT BECOMES EFFECTIVE ON 09/06/06..... AND EXTENDS FOR A PERIOD OF ONE (1) YEAR OR UNTIL SUCH "REASONABLE TIME" THEREAFTER AS IS NECESSARY TO OBTAIN A NEW CONTRACT OR RENEW THE</p>						

SEE REVERSE SIDE FOR TERMS AND CONDITIONS

SIGNATURE	TELEPHONE	DATE
	(800) 435-9959	09/05/06
TITLE	FFIN	ADDRESS CHANGES TO BE NOTED ABOVE
Sales Representative	55-065-9314-001	

WHEN RESPONDING TO RFQ, INSERT NAME AND ADDRESS IN SPACE ABOVE LABELED 'VENDOR'



State of West Virginia  
 Department of Administration  
 Purchasing Division  
 2019 Washington Street East  
 Post Office Box 50130  
 Charleston, WV 25305-0130

# Request for Quotation

RFQ NUMBER
707EC004

PAGE
2

ADDRESS CORRESPONDENCE TO ATTENTION OF:
JOHN JOHNSTON 304-558-2402

**VENDOR**

\*709054056      304-345-2851  
 VALLEY AIR INC  
 PO BOX 6516  
 CHARLESTON WV 25362

**SHIP TO**

DIVISION OF HIGHWAYS  
 EQUIPMENT DIVISION  
 ROUTE 33  
 BRUSHY FORK ROAD  
 BUCKHANNON, WV  
 26201      304-472-1750

DATE PRINTED	TERMS OF SALE	SHIP VIA	F.O.B.	FREIGHT TERMS
07/27/2006	Net 30 Days	Motor Truck	Buckhannon, WV	Prepaid

BID OPENING DATE: 09/06/2006      BID OPENING TIME 01:30PM

LINE	QUANTITY	UOP	CAT NO.	ITEM NUMBER	UNIT PRICE	AMOUNT
<p>ORIGINAL CONTRACT. THE "REASONABLE TIME" PERIOD SHALL NOT EXCEED TWELVE (12) MONTHS. DURING THIS "REASONABLE TIME" THE VENDOR MAY TERMINATE THIS CONTRACT FOR ANY REASON UPON GIVING THE DIRECTOR OF PURCHASING THIRTY (30) DAYS WRITTEN NOTICE.</p> <p>UNLESS SPECIFIC PROVISIONS ARE STIPULATED IN THIS CONTRACT DOCUMENT, THE TERMS, CONDITIONS, AND PRICING SET HEREIN ARE FIRM FOR THE LIFE OF THE CONTRACT.</p> <p>RENEWAL: THIS CONTRACT MAY BE RENEWED UPON THE MUTUAL WRITTEN CONSENT OF THE SPENDING UNIT AND VENDOR, SUBMITTED TO THE DIRECTOR OF PURCHASING THIRTY (30) DAYS PRIOR TO THE EXPIRATION DATE. SUCH RENEWAL SHALL BE IN ACCORDANCE WITH THE TERMS AND CONDITIONS OF THE ORIGINAL CONTRACT AND SHALL BE LIMITED TO TWO (2) ONE (1) YEAR PERIODS.</p> <p>CANCELLATION: THE DIRECTOR OF PURCHASING RESERVES THE RIGHT TO CANCEL THIS CONTRACT IMMEDIATELY UPON WRITTEN NOTICE TO THE VENDOR IF THE COMMODITIES AND/OR SERVICES SUPPLIED ARE OF AN INFERIOR QUALITY OR DO NOT CONFORM WITH THE SPECIFICATIONS OF THE BID AND CONTRACT HEREIN.</p> <p>OPEN MARKET CLAUSE: THE DIRECTOR OF PURCHASING MAY AUTHORIZE A SPENDING UNIT TO PURCHASE ON THE OPEN MARKET, WITHOUT THE FILING OF A REQUISITION OR COST ESTIMATE, ITEMS SPECIFIED ON THIS CONTRACT FOR IMMEDIATE DELIVERY IN EMERGENCIES DUE TO UNFORESEEN CAUSES (INCLUDING BUT NOT LIMITED TO DELAYS IN TRANSPORTATION OR AN UNANTICIPATED INCREASE IN THE VOLUME OF WORK).</p> <p>QUANTITIES: QUANTITIES LISTED IN THE REQUISITION ARE APPROXIMATIONS ONLY, BASED ON ESTIMATES SUPPLIES BY THE STATE SPENDING UNIT. IT IS UNDERSTOOD AND AGREED THAT THE CONTRACT SHALL COVER THE QUANTITIES ACTUALLY</p>						

SEE REVERSE SIDE FOR TERMS AND CONDITIONS

SIGNATURE	TELEPHONE	DATE
	(800) 435-9959	09/05/06
TITLE	FEDIN	ADDRESS CHANGES TO BE NOTED ABOVE
Sales Representative	55-065-9314-001	

WHEN RESPONDING TO RFQ, INSERT NAME AND ADDRESS IN SPACE ABOVE LABELED 'VENDOR'



State of West Virginia  
 Department of Administration  
 Purchasing Division  
 2019 Washington Street East  
 Post Office Box 50130  
 Charleston, WV 25305-0130

# Request for Quotation

RFQ NUMBER
707EC004

PAGE
3

ADDRESS CORRESPONDENCE TO ATTENTION OF:
JOHN JOHNSTON 304-558-2402

VENDOR	*709054056	304-345-2851
	VALLEY AIR INC	
	PO BOX 6516	
	CHARLESTON WV 25362	

SHIP TO	DIVISION OF HIGHWAYS
	EQUIPMENT DIVISION
	ROUTE 33
	BRUSHY FORK ROAD
	BUCKHANNON, WV 26201
	304-472-1750

DATE PRINTED	TERMS OF SALE	SHIP VIA	F.O.B.	FREIGHT TERMS
07/27/2006	Net 30 Days	Motor Truck	Buckhannon, WV	Prepaid
BID OPENING DATE: 09/06/2006		BID OPENING TIME 01:30PM		

LINE	QUANTITY	UOP	CAT NO	ITEM NUMBER	UNIT PRICE	AMOUNT
<p>ORDERED FOR DELIVERY DURING THE TERM OF CONTRACT, WHETHER MORE OR LESS THAN THE QUANTITIES SHOWN.</p> <p>ORDERING PROCEDURE: SPENDING UNIT(S) SHALL ISSUE A WRITTEN EQUIPMENT CONTRACT ORDER (FORM NUMBER WV-35) FOR COMMODITIES COVERED BY THIS CONTRACT. THE ORIGINAL WV-35 MUST BE SENT TO THE PURCHASING DIVISION OF THE DEPARTMENT OF ADMINISTRATION. AFTER APPROVAL AND ENCUMBRANCE, ONE COPY OF THE PURCHASE ORDER WILL BE RETURNED TO THE SPENDING UNIT AND ONE COPY FORWARDED TO THE VENDOR AS AUTHORIZATION FOR SHIPMENT. NO ORDER IS VALID UNLESS APPROVED AND ENCUMBERED BY THE PURCHASING DIVISION.</p> <p>BANKRUPTCY: IN THE EVENT THE VENDOR/CONTRACTOR FILES FOR BANKRUPTCY PROTECTION, THIS CONTRACT IS AUTOMATICALLY NULL AND VOID, AND IS TERMINATED WITHOUT FURTHER ORDER.</p> <p>REV. 9/98</p> <p>EXHIBIT 6</p> <p>PRICE ADJUSTMENT PROVISION:            THE STATE OF WEST VIRGINIA WILL CONSIDER BIDS THAT CONTAIN PROVISIONS FOR PRICE ADJUSTMENTS PRIOR TO THE ORIGINAL EXPIRATION OF THE CONTRACT, PROVIDED THAT SUCH PRICE ADJUSTMENT COVERS BOTH UPWARD AND DOWNWARD MOVEMENT OF THE COMMODITY PRICE, AND THAT ADJUSTMENT IS BASED ON THE "PASS THROUGH" INCREASE OR DECREASE OF RAW MATERIALS AND/OR LABOR, WHICH MAKE UP ALL OR A SUBSTANTIAL PART OF A PRODUCT. ADJUSTMENTS ARE TO BE BASED UPON AN ACTUAL DOLLAR FIGURE, NOT A PERCENTAGE. ALL PRICE ADJUSTMENT REQUESTS MUST BE SUBSTANTIATED IN A MANNER ACCEPTABLE TO THE DIRECTOR PURCHASING, E.G.</p>						

SEE REVERSE SIDE FOR TERMS AND CONDITIONS

SIGNATURE	TELEPHONE	DATE
	(800) 435-9959	09/05/06
TITLE	FEIN	ADDRESS CHANGES TO BE NOTED ABOVE
Sales Representative	55-065-9314-001	

WHEN RESPONDING TO RFQ, INSERT NAME AND ADDRESS IN SPACE ABOVE LABELED 'VENDOR'



State of West Virginia  
 Department of Administration  
 Purchasing Division  
 2019 Washington Street East  
 Post Office Box 50130  
 Charleston, WV 25305-0130

# Request for Quotation

RFQ NUMBER
707EC004

PAGE
4

ADDRESS CORRESPONDENCE TO ATTENTION OF:
JOHN JOHNSTON 304-558-2402

VENDOR

\*709054056                      304-345-2851  
 VALLEY AIR INC  
 PO BOX 6516  
 CHARLESTON WV 25362

SHIP TO

DIVISION OF HIGHWAYS  
 EQUIPMENT DIVISION  
 ROUTE 33  
 BRUSHY FORK ROAD  
 BUCKHANNON, WV  
 26201                      304-472-1750

DATE PRINTED	TERMS OF SALE	SHIP VIA	F.O.B.	FREIGHT TERMS
07/27/2006	Net 30 Days	Motor Truck	Buckhannon, WV	Prepaid
BID OPENING DATE: 09/06/2006		BID OPENING TIME 01:30PM		

LINE	QUANTITY	UOP	CAT NO.	ITEM NUMBER	UNIT PRICE	AMOUNT
<p>GOVERNMENTAL BENCH MARKS, GENERAL MARKET INCREASE, PUBLISHED PRICE LISTS. SUCH REQUESTS FOR AND INCREASE SHOULD BE RECEIVED IN WRITING BY THE DIRECTOR OF PURCHASING AT LEAST 30 DAYS IN ADVANCE OF THE EFFECTIVE DATE OF THE INCREASE. ANY TIME THE VENDOR REQUESTS A PRICE ADJUSTMENT, THE PURCHASING DIVISION MAY EITHER ACCEPT THE PRICE ADJUSTMENT AND AMEND THE CONTRACT ACCORDINGLY OR REJECT THE ADJUSTMENT IN ITS ENTIRETY AND CANCEL THE CONTRACT.</p> <p>VENDOR PREFERENCE CERTIFICATE</p> <p>CERTIFICATION AND APPLICATION* IS HEREBY MADE FOR PREFERENCE IN ACCORDANCE WITH WEST VIRGINIA CODE, 5A-3-37 (DOES NOT APPLY TO CONSTRUCTION CONTRACTS).</p> <p>A. APPLICATION IS MADE FOR 2.5% PREFERENCE FOR THE REASON CHECKED:</p> <p>( ) BIDDER IS AN INDIVIDUAL RESIDENT VENDOR AND HAS RESIDED CONTINUOUSLY IN WEST VIRGINIA FOR FOUR (4) YEARS IMMEDIATELY PRECEDING THE DATE OF THIS CERTIFICATION; OR</p> <p>(X) BIDDER IS A PARTNERSHIP, ASSOCIATION OR CORPORATION RESIDENT VENDOR AND HAS MAINTAINED ITS HEAD-QUARTERS OR PRINCIPAL PLACE OF BUSINESS CONTINUOUSLY IN WEST VIRGINIA FOR FOUR (4) YEARS IMMEDIATELY PRECEDING THE DATE OF THIS CERTIFICATION; OR 80% OF THE OWNERSHIP INTEREST OF BIDDER IS HELD BY ANOTHER INDIVIDUAL, PARTNERSHIP, ASSOCIATION OR CORPORATION RESIDENT VENDOR WHO HAS MAINTAINED ITS HEADQUARTERS OR PRINCIPAL PLACE OF BUSINESS CONTINUOUSLY IN WEST VIRGINIA FOR FOUR (4) YEARS IMMEDIATELY PRECEDING THE DATE OF THIS CERTIFICATION; OR</p>						

SEE REVERSE SIDE FOR TERMS AND CONDITIONS

SIGNATURE	TELEPHONE	DATE
	(800) 435-9959	09/05/06
TITLE	ADDRESS CHANGES TO BE NOTED ABOVE	
Sales Representative FEIN 55-065-9314-001		

WHEN RESPONDING TO RFQ, INSERT NAME AND ADDRESS IN SPACE ABOVE LABELED 'VENDOR'



State of West Virginia  
 Department of Administration  
 Purchasing Division  
 2019 Washington Street East  
 Post Office Box 50130  
 Charleston, WV 25305-0130

# Request for Quotation

RFO NUMBER
707EC004

PAGE
5

ADDRESS CORRESPONDENCE TO ATTENTION OF:
JOHN JOHNSTON 304-558-2402

VENDOR

\*709054056      304-345-2851  
 VALLEY AIR INC  
 PO BOX 6516  
 CHARLESTON WV 25362

SHIP TO

DIVISION OF HIGHWAYS  
 EQUIPMENT DIVISION  
 ROUTE 33  
 BRUSHY FORK ROAD  
 BUCKHANNON, WV  
 26201      304-472-1750

DATE PRINTED	TERMS OF SALE	SHIP VIA	F.O.B.	FREIGHT TERMS
07/27/2006	Net 30 Days	Motor Truck	Buckhannon, WV	Prepaid

BID OPENING DATE: **09/06/2006**      BID OPENING TIME **01:30PM**

LINE	QUANTITY	UOP	CAT NO	ITEM NUMBER	UNIT PRICE	AMOUNT
<p>( ) BIDDER IS A CORPORATION NONRESIDENT VENDOR WHICH HAS AN AFFILIATE OR SUBSIDIARY WHICH EMPLOYS A MINIMUM OF ONE HUNDRED STATE RESIDENTS AND WHICH HAS MAINTAINED ITS HEADQUARTERS OR PRINCIPAL PLACE OF BUSINESS WITHIN WEST VIRGINIA CONTINUOUSLY FOR THE FOUR (4) YEARS IMMEDIATELY PRECEDING THE DATE OF THIS CERTIFICATION.</p> <p>B. APPLICATION IS MADE FOR 2.5% PREFERENCE FOR THE REASON CHECKED:</p> <p>(X) BIDDER IS A RESIDENT VENDOR WHO CERTIFIES THAT, DURING THE LIFE OF THE CONTRACT, ON AVERAGE AT LEAST 75% OF THE EMPLOYEES WORKING ON THE PROJECT BEING BID ARE RESIDENTS OF WEST VIRGINIA WHO HAVE RESIDED IN THE STATE CONTINUOUSLY FOR THE TWO YEARS IMMEDIATELY PRECEDING SUBMISSION OF THIS BID;</p> <p>OR</p> <p>( ) BIDDER IS A NONRESIDENT VENDOR EMPLOYING A MINIMUM OF ONE HUNDRED STATE RESIDENTS OR IS A NONRESIDENT VENDOR WITH AN AFFILIATE OR SUBSIDIARY WHICH MAINTAINS ITS HEADQUARTERS OR PRINCIPAL PLACE OF BUSINESS WITHIN WEST VIRGINIA EMPLOYING A MINIMUM OF ONE HUNDRED STATE RESIDENTS WHO CERTIFIES THAT, DURING THE LIFE OF THE CONTRACT, ON AVERAGE AT LEAST 75% OF THE EMPLOYEES OR BIDDERS' AFFILIATE'S OR SUBSIDIARY'S EMPLOYEES ARE RESIDENTS OF WEST VIRGINIA WHO HAVE RESIDED IN THE STATE CONTINUOUSLY FOR THE TWO YEARS IMMEDIATELY PRECEDING SUBMISSION OF THIS BID.</p> <p>BIDDER UNDERSTANDS IF THE SECRETARY OF TAX &amp; REVENUE DETERMINES THAT A BIDDER RECEIVING PREFERENCE HAS FAILED TO CONTINUE TO MEET THE REQUIREMENTS FOR SUCH PREFERENCE, THE SECRETARY MAY ORDER THE DIRECTOR OF PURCHASING TO: (A) RESCIND THE CONTRACT OR PURCHASE ORDER ISSUED; OR (B) ASSESS A PENALTY AGAINST SUCH</p>						

SEE REVERSE SIDE FOR TERMS AND CONDITIONS

SIGNATURE	TELEPHONE	DATE
	(800) 435-9959	09/05/06
TITLE	FEIN	ADDRESS CHANGES TO BE NOTED ABOVE
Sales Representative	55-065-9314-001	

WHEN RESPONDING TO RFO, INSERT NAME AND ADDRESS IN SPACE ABOVE LABELED 'VENDOR'



State of West Virginia  
 Department of Administration  
 Purchasing Division  
 2019 Washington Street East  
 Post Office Box 50130  
 Charleston, WV 25305-0130

# Request for Quotation

RFQ NUMBER
707EC004

PAGE
6

ADDRESS CORRESPONDENCE TO ATTENTION OF:
JOHN JOHNSTON 304-558-2402

VENDOR

\*709054056      304-345-2851  
 VALLEY AIR INC  
 PO BOX 6516  
 CHARLESTON WV 25362

SHIP TO

DIVISION OF HIGHWAYS  
 EQUIPMENT DIVISION  
 ROUTE 33  
 BRUSHY FORK ROAD  
 BUCKHANNON, WV  
 26201      304-472-1750

DATE PRINTED	TERMS OF SALE	SHIP VIA	F.O.B.	FREIGHT TERMS
07/27/2006	Net 30 Days	Motor Truck	Buckhannon, WV	Prepaid
BID OPENING DATE: 09/06/2006		BID OPENING TIME 01:30PM		

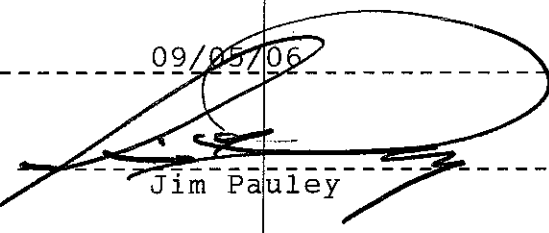
LINE	QUANTITY	UOP	CAT NO.	ITEM NUMBER	UNIT PRICE	AMOUNT
<p>BIDDER IN AN AMOUNT NOT TO EXCEED 5% OF THE BID AMOUNT AND THAT SUCH PENALTY WILL BE PAID TO THE CONTRACTING AGENCY OR DEDUCTED FROM ANY UNPAID BALANCE ON THE CONTRACT OR PURCHASE ORDER.</p> <p>BY SUBMISSION OF THIS CERTIFICATE, BIDDER AGREES TO DISCLOSE ANY REASONABLY REQUESTED INFORMATION TO THE PURCHASING DIVISION AND AUTHORIZES THE DEPARTMENT OF TAX AND REVENUE TO DISCLOSE TO THE DIRECTOR OF PURCHASING APPROPRIATE INFORMATION VERIFYING THAT BIDDER HAS PAID THE REQUIRED BUSINESS TAXES, PROVIDED THAT SUCH INFORMATION DOES NOT CONTAIN THE AMOUNTS OF TAXES PAID NOR ANY OTHER INFORMATION DEEMED BY THE TAX COMMISSIONER TO BE CONFIDENTIAL.</p> <p>UNDER PENALTY OF LAW FOR FALSE SWEARING (WEST VIRGINIA CODE 61-5-3), BIDDER HEREBY CERTIFIES THAT THIS CERTIFICATE IS TRUE AND ACCURATE IN ALL RESPECTS; AND THAT IF A CONTRACT IS ISSUED TO BIDDER AND IF ANYTHING CONTAINED WITHIN THIS CERTIFICATE CHANGES DURING THE TERM OF THE CONTRACT, BIDDER WILL NOTIFY THE PURCHASING DIVISION IN WRITING IMMEDIATELY.</p> <p>BIDDER: ----- Valley Air Inc.</p> <p>DATE: ----- 09/05/06</p> <p>SIGNED: -----  Jim Pauley</p> <p>TITLE: ----- Sales Representative</p> <p>* CHECK ANY COMBINATION OF PREFERENCE CONSIDERATION(S)</p>						

SEE REVERSE SIDE FOR TERMS AND CONDITIONS

SIGNATURE	TELEPHONE	DATE
	(800) 435-9959	09/05/06
TITLE	FEIN	ADDRESS CHANGES TO BE NOTED ABOVE
Sales Representative	55-065-9314-001	

WHEN RESPONDING TO RFQ, INSERT NAME AND ADDRESS IN SPACE ABOVE LABELED 'VENDOR'





State of West Virginia  
 Department of Administration  
 Purchasing Division  
 2019 Washington Street East  
 Post Office Box 50130  
 Charleston, WV 25305-0130

# Request for Quotation

RFQ NUMBER
707EC004

PAGE
8

ADDRESS CORRESPONDENCE TO ATTENTION OF:
JOHN JOHNSTON 304-558-2402

VENDOR

\*709054056      304-345-2851  
 VALLEY AIR INC  
 PO BOX 6516  
 CHARLESTON WV 25362

SHIP TO

DIVISION OF HIGHWAYS  
 EQUIPMENT DIVISION  
 ROUTE 33  
 BRUSHY FORK ROAD  
 BUCKHANNON, WV  
 26201      304-472-1750

DATE PRINTED	TERMS OF SALE	SHIP VIA	F.O.B.	FREIGHT TERMS
07/27/2006	Net 30 Days	Motor Truck	Buckhannon, WV	Prepaid
BID OPENING DATE: 09/06/2006		BID OPENING TIME 01:30PM		

LINE	QUANTITY	UOP	CAT NO	ITEM NUMBER	UNIT PRICE	AMOUNT
				(304) 345-2856		
				CONTACT PERSON (PLEASE PRINT CLEARLY):		
				Jim Pauley		
***** THIS IS THE END OF RFQ 707EC004 ***** TOTAL:						15,596.00

SEE REVERSE SIDE FOR TERMS AND CONDITIONS

SIGNATURE	TELEPHONE	DATE
	(800) 435-9959	09/05/06
TITLE	FEIN	ADDRESS CHANGES TO BE NOTED ABOVE
Sale Representative	55-065-9314-001	

WHEN RESPONDING TO RFQ, INSERT NAME AND ADDRESS IN SPACE ABOVE LABELED 'VENDOR'



WEST VIRGINIA DEPARTMENT OF TRANSPORTATION  
DIVISION OF HIGHWAYS  
EQUIPMENT DIVISION

PROCUREMENT SPECIFICATIONS

NO. 612-3-K

185 CFM AIR COMPRESSOR/PORTABLE

1.0 PURPOSE

It is the purpose of these specifications to describe a 185 CFM Air Compressor/Portable (hereinafter referred to as a "compressor" or a "unit") to be purchased for use by the West Virginia Division of Highways (DOH) on an Open End Contract basis.

2.0 BIDDING PROCEDURES

The current purchasing procedures regarding bidding as established by the Department of Administration, Purchasing Division shall apply. Failure to submit the "Request for Quotation" forms, complete in its entirety and according to directions indicated, may subject the bidder to disqualification. Each bid submitted shall also be accompanied by a Bidder's Evaluation Report completed in detail. **FAILURE TO SUBMIT THE BIDDER'S EVALUATION REPORT, COMPLETE IN ITS ENTIRETY, MAY RESULT IN AUTOMATIC DISQUALIFICATION.**

3.0 SPECIFICATIONS

The specifications named herein, mandatory and non-mandatory, establish the acceptable level of quality only and are not intended to reflect a preference or favor any particular brand or vendor.

3.1 EXCEPTIONS TO NON-MANDATORY SPECIFICATIONS

Exception to a non-mandatory unit specification may be made by the bidder, providing the exception is not available from the manufacturer. Any such exception must be noted on the bidder's evaluation report and should be accompanied by supporting documentation/literature from the manufacturer. Any exception must be indicated on a separate attachment to the bidder's evaluation report and labeled as "Exception to Specifications". The state reserves the right to determine whether the stated exception does or does not reduce the quality and performance of the unit. Failure to provide information for any exceptions may be grounds for rejection of the bid. The state reserves the right to waive minor irregularities in bids or specifications in accordance with §148-1-4(f) of the WV Legislative Rules and Regulations.

### 3.2 MANDATORY SPECIFICATIONS

All specifications preceded by "shall and/or must" or are stated as a "minimum and/or maximum" are mandatory. Any bid failing to meet any mandatory item shall be immediately disqualified. Failure to respond in the appropriate evaluation section may also be grounds for immediate disqualification at the discretion of the State.

A mandatory pre-bid conference is scheduled for this equipment purchase as stated in the RFQ. Vendors having products with variations or exceptions in specified mandatory items are expected to address any such variations or exceptions during the pre-bid conference. The State shall review and consider any such variation or exception, and may at its sole discretion, issue an addendum to change mandatory specifications deemed to be in the State's best interest. Bids from any vendor failing to attend the mandatory pre-bid shall be disqualified. Bids containing any variation or exception to a mandatory specification that was not addressed during the pre-bid conference and accepted by the issuance of an Addendum shall be disqualified.

### 4.0 REPRESENTATIVE UNIT FOR TEST

The successful vendor must (if specified) provide DOH one (1) completed representative unit to be observed and evaluated on the first order only to insure compliance with specification. If requested, the time period for testing and evaluation shall be seven (7) calendar days following receipt of the unit. DOH will incur no obligation for deterioration of surfaces, finishes, seals, and mechanical or electrical parts on the unit resulting from operation and testing within the limits of these specifications; nor will DOH incur obligation for damage to the unit resulting from failure to meet specifications when due care and attention is given by DOH and testing is done within the limits of these specifications. Failure of the pilot unit to satisfactorily meet specifications as bid shall be cause for cancellation of the purchase order, and return of the delivered unit along with all associated equipment to the vendor at the vendors expense.

#### 4.1 CONDITION OF UNIT(S) UPON DELIVERY

All units must arrive at the prescribed delivery point having been completely preserviced with oil, lubricants, and coolant. All prescribed precautions pertaining to first operations and break-in of the unit are to be posted conspicuously on the unit for ready observance by the operator.

#### 4.2 DELIVERY

Delivery point of the completely assembled representative unit will be the DOH, Equipment Division, Route 33 at Brushy Fork Road, Buckhannon, West Virginia (26201).

The vendor is responsible for guaranteeing delivery of the completed units within the time specified and agreed to by the State. Delivery is preferred within 45 days. The

vendor is responsible for establishing and coordinating delivery terms with allied manufacturers or suppliers. Delivery terms shall be stated in the bid and the State reserves the right to accept or negotiate such terms. Failure to reach an agreement may result in rejection of the bid. The successful bidder shall provide their manufacturer's confirmation of the order to the WVDOH contact person within seven (7) working days after receiving the approved purchase order.

A completed pilot model for inspection must be provided within 45 calendar days after the date of the purchase agreement by the successful vendor.

Delivery is an integral part of this specification and failure to comply will be cause to initiate a D.O.T. Administrative Form WV-82, Vendor Performance Form. The WV-82 Form will provide a means of officially notifying the Purchasing Division and the vendor of unsatisfactory performance; such as late deliveries, poor service, inadequate parts supplies, etc.

The decision to initiate subject Form will be at the sole discretion of the D.O.H. Commissioner's established Equipment Review Board.

Issuance of the WV-82 Vendor Complaint Form on unsatisfactory delivery against any vendor will be cause to refuse to consider similar items from those vendors on future Request For Quotations

(NOTE: Delivery time could be altered due to labor strikes, severe inclement weather conditions, etc.)

## 5.0 AWARD CRITERIA

- 5.1 DOH will recommend the award in accordance with the RFQ evaluation criteria described in the requisition. The award shall be made to the lowest unit cost vendor that meets or exceeds the specifications.

Prices for the units shall be in quantities of 1-5 and 6-10. However, for evaluation purposes, we will use quantities 1-5. DOH reserves the right to place multiple orders in any quantity.

## 6.0 SPECIFICATIONS AND GUIDELINES - GENERAL

### 6.1 IDENTIFICATION OF THE UNIT BEING PROPOSED

The bidder must identify the unit by manufacturer, model, series, and year of manufacture, in the bid to enable identification by DOH in the manufacturer's specifications of the proposed unit. The bidder will submit complete descriptive literature of the proposed unit, to establish that the bid is the manufacturer's most current model, including latest engineering improvements, which have been, or will imminently be, regularly advertised and sold on the open market. The unit specified herein and offered to be manufactured after January 1, 2006 and be clearly identified and marked with date of manufacture.

## 6.2 OPERATING AND SERVICE MANUALS AND PARTS LISTS

An operator's manual must be included with each unit upon delivery. A "line sheet" (if applicable) and Equipment Preventative Maintenance Questionnaire (as shown in X6.2 of the Bidder's Evaluation Report) must be with pilot unit upon delivery. In addition, there must be 12 service, shop, or maintenance manuals; ten (10) to be distributed to the Districts and two (2) for the Equipment Division. Also, there must be 14 parts manuals; ten (10) to be distributed to the Districts and four (4) for Equipment Division use. CD ROM is preferred in lieu of parts manuals.

\* NOTE: MANUALS SHALL BE DELIVERED UPON COMPLETION OF DELIVERY OF TOTAL UNITS. FAILURE TO DO SO WILL DELAY PAYMENT.

## 6.3 TRAINING:

Manufacturers and/or dealers will be required to stage a thorough seminar on the subjects of Preventative Maintenance, Operator and Mechanic Training. In order to keep the operators and mechanics updated, the successful vendor shall conduct training with each purchase order against this open end contract. Training is preferred within 2 working days after delivery of the pilot unit on the individual purchase order.

Manufacturers and/or dealers shall be required to furnish the Training Academy with one (1) Operator's Manual.

The seminar to be held at the W. Va. Division of Highways, Equipment Division, Buckhannon, West Virginia.

## 6.4 PREVENTIVE MAINTENANCE AND OPERATOR PROCEDURES:

Manufacturers and/or dealers will be required to submit to the Equipment Division, in addition to the operating and service manuals, booklets and pamphlets explaining the Preventive Maintenance and Operator Procedures to be used by the operators of this equipment, and must include such things as daily prestart inspection procedure, service schedule, and routine maintenance required, safety precautions, etc.

The successful vendor shall furnish all training aids; i.e., videos, projectors, etc. required in conducting the training.

## 6.5 WARRANTY AND SERVICE POLICY

The Manufacturers warranty or service policy is to apply to the unit. Such warranty or service policy is to be recognized at any authorized unit dealer, representing manufacturer of proposed unit throughout the State of West Virginia. The applicable warranty or service policy will not be contingent upon obtaining routine service, lubrication, and servicing of the unit from factory authorized agencies. It will be the responsibility of the bidder to have available labor to repair or replace any defective

replacement parts, components and materials, and to have available those replacement parts, components, and/or materials found to be defective during the terms of the warranty period. The bidder should state the labor rates, locations where parts will be stocked, availability of parts, and discounts offered for parts, when terms of the warranty offer a pro-rated cost for parts and labor. In addition, the successful bidder should offer field work to repair or replace defective parts, components, and materials found to be defective during the terms of the warranty and should provide mechanic's travel rates, mileage charges, field mechanic rates, and any surcharge for miscellaneous items, if applicable, for field work during the warranty period. Submit to Division of Highways any technical or engineering improvements during the term of the warranty. The unit must be accompanied upon delivery by the unit's manufacturer's executed warranty or service policy.

THE "WARRANTY AND SERVICE POLICY QUESTIONNAIRE" ATTACHED IN THE BIDDER'S EVALUATION REPORT MUST BE COMPLETED IN ITS ENTIRETY BY THE SUCCESSFUL BIDDER OR MANUFACTURER PRIOR TO DELIVERY OF THE PILOT MODEL. (SEE SECTION X6.5 OF BIDDER'S EVALUATION REPORT).

#### 6.6 EVALUATION COMMITTEE REQUIREMENTS

Detailed component specifications, product literature, component models, required for specification compliance determination by the Evaluation Committee should be provided with each bid. Any information supplied that is contrary to/or conflicting with the specifications and/or attached Bidders Evaluation Report may be sufficient cause for rejection of bid.

#### 6.7 UNSPECIFIED ACCESSORIES & FEATURES

All parts, equipment, accessories, material, design and performance characteristics not specified herein, but which are necessary to provide a complete unit, must be furnished with each unit and required to conform to strength, quality of material, and quality of workmanship to those which are advertised and provided to the market in general by the unit industry.

All parts and accessories advertised and regularly supplied as standard shall be included, except those which would represent duplication of these specified, and except those which, by specification, are not to be furnished. All standard safety features, required by Federal and State Law, shall be included

- 7.0 SPECIFICATIONS OF THE QUOTED UNIT ARE AS FOLLOWS:
- 7.1 Compressor:
- 7.1.1 Single stage rotary screw type.
  - 7.1.1.1 Self contained, fully enclosed heavy duty portable air compressor.
  - 7.1.2 Free air capacity 185 CFM.
  - 7.1.3 Lubrication: Oil flooded or pressure type to provide sealing, lubrication, and cooling of air pump.
  - 7.1.4 Oil filter replaceable element or spin-on flow type.
  - 7.1.5 Air intake filter dry type with maintenance signal.
  - 7.1.6 Bearings anti-friction type, heaviest duty offered.
- 7.2 Air Receiver shall be ASME code construction and have a working pressure of 100 PSIG, minimum.
- 7.2.1 Air receiver capacity 1.05 cubic feet minimum with safety valve and two (2) 3/4 inch service valves, universal type.
  - 7.2.2 Discharge line to be fitted with an automatic discharge moisture trap. Size and capacity determined by manufacturer for compressor ratings and to be located between air receiver and service valve.
  - 7.2.3 Two (2) discharge line lubricators - one (1) quart capacity each, to each outlet, to be fitted and easily accessible.
- 7.3 Engine:
- 7.3.1 Engine to be diesel powered, water cooled.
  - 7.3.1.1 Unit to have a minimum of 49 BHP at a continuous rated speed of approximately 2300 RPM.
  - 7.3.2 To have a twelve (12) volt electrical system. Heaviest duty system and batteries offered.
  - 7.3.3 Fuel tank capacity 20 US gallon minimum.
  - 7.3.4 Rain cap to protect engine and muffler.

- 7.4 Cooling System shall be of sufficient capacity to allow engine and compressor to operate at rated air delivery and pressure continuously.
- 7.4.1 Engine coolant rated at -32 degrees F.
- 7.5. Safety Devices and Instrumentation:
  - 7.5.1 Automatic blow-down valve.
  - 7.5.2 Engine shutdown devices to be activated by high discharge air temperature, low engine oil pressure, and high engine temperature
  - 7.5.3 Excess air flow safety valve and a minimum pressure valve
  - 7.5.4 The following gauges to be included in the units instrument panel:
    - 7.5.4.1 Tachometer, engine RPM.
    - 7.5.4.2 Ammeter or voltmeter
    - 7.5.4.3 Engine temperature gauge.
    - 7.5.4.4 Engine oil pressure gauge.
    - 7.5.4.5 Discharge air pressure gauge
    - 7.5.4.6 Fuel gauge
    - 7.5.4.7 Hour Meter
- 7.6 Start and stop controls to be located on control panel.
- 7.7 Operation, maintenance and instruction decals to be located in a conspicuous place near controls
- 7.8 Controls 0-100 percent demand type, controlling engine speed and intake of air compressor.
- 7.9 Accessories:
  - 7.9.1 Service drain valve.
  - 7.9.2 Vandalism protection kit(s).

- 7.9.3 Lockable tool boxes.
- 7.9.4 One (1) set of replacement filters for compressor air and lube oil and engine air, fuel and lube oil, included with delivery of each unit.
- 7.9.5 Lifting bail, single point.
- 7.9.6 Twin hose reels capable of holding 50 foot x 1 inch O D. hose.
- 7.10 Compressor shall be mounted on a two (2) wheeled type towing trailer and to meet the following criteria:
  - 7.10.1 Engine and compressor to be frame mounted in a manner to minimize vibration.
  - 7.10.2 Suspension shall be of sufficient strength and handling of unit at a top speed of 55 MPH
  - 7.10.3 Retractable, swivel type third wheel.
  - 7.10.4 Tires: P205/75R15 load range C, highway tread.  
Wheel: drop center 7 inches wide.
  - 7.10.5 Hub to be equipped with trailer wheel bearing protector (bearing Buddy Model 1980 or equal).
  - 7.10.6 Drawbar with pintle eye and safety chain.
  - 7.10.7 Stop lights, tail lights, directional indicators, (LED type) license plate light and license plate bracket.
  - 7.10.8 Cole Hersee No. 12081 (or approved equal) male plug for towing vehicle.
  - 7.10.9 Trailer shall meet or exceed all applicable West Virginia Department of Motor Vehicle codes and be towable at speeds up to 55 MPH.
- 7.11 Paint: The unit should be painted as described
  - 7.11.1 The unit is to be painted white, Federal Standard White 595A (No. 17875) or equal.
  - 7.11.2 Detail/Decorative Stripes with logo:  
Width: Approximately 2 inches  
  
DOT, DOH logo (to be supplied by DOH) is attached (black and white copy) and is approximately 7 inches tall by 7 inches wide Area behind logo and with 2 inch of



logo is not to be striped

Upper stripe color: Dark Blue.

Lower stripe color: Light Gold

Bidder should consult with the DOT, DOH of proposal for striping before submitting final bid. (Tape for stripes is acceptable.)

- 7.11.3 Bidder should attach his proposed paint plan with this bid. It should include chips or samples of proposed paints as well as a proposed striping detail on a cab silhouette sheet. Bidder may modify attached striping plan to fit his particular hood or cab shape.
- 7.11.4 In order to test the adhesive quality of the paint, the DOH may, at its option, require that the vendor measure adhesion by the criteria set forth in ASTM D3359-74, Method B. A rating of less than 4 on this test would be deemed unacceptable.
- 7.11.5 The procedures used by the manufacturer in cleaning, degreasing, priming, and painting are sufficient to meet this requirement except that the manufacturer should substitute white paint (of equivalent grade or quality to manufacturer's standard colored paint) for manufacturer's standard paint in the finish coats.
- 7.11.6 The Department is desirous of avoiding units painted white over top the standard color. However, if bidder/manufacturer is unable to substitute white paint in its normal plant painting procedure, the bidder should state so and offer his proposed paint method
- 7.11.7 Areas not normally painted the manufacturers standard color(s) on standard units (e.g. some rubber parts, mirrors, exhaust pipe etc.) Are not to be painted white on units specified herein. Also, areas painted a distinct color (e.g. safety reasons) should be painted as they normally would
- 7.12 Vendor must certify that unit offered will meet or exceed the Occupational Safety and Health Act of 1970" or subsequent changes that are in effect at time of manufacture of the unit.
- 7.13 Advertising: Only one manufacturer's name decal, which must include the model number, may appear on the exterior of the unit. Logos created through the stamping or casting process of manufacture are also acceptable. No logos will interfere with the Divisions logo striping and decal.

NOTE: Vendor should type Bidder's Evaluation Report

WEST VIRGINIA DEPARTMENT OF TRANSPORTATION  
DIVISION OF HIGHWAYS  
EQUIPMENT DIVISION

BIDDER'S EVALUATION REPORT

PROCUREMENT SPECIFICATIONS FOR OPEN END CONTRACT

NO. 612-3-K

185 CFM AIR COMPRESSOR/PORTABLE

NOTE TO BIDDER: Procurement Specification No. 612-3-K, Paragraph 2.0 recommends the completion and submittal of this Report with your bid. Purpose of this Report is to enable the West Virginia Division of Highways Evaluation Committee to make full and fair evaluation of the bid. FAILURE TO SUBMIT THIS REPORT, COMPLETE IN ITS ENTIRETY, MAY SUBJECT THE BIDDER TO DISQUALIFICATION

Reference Requisition No 707EC004

Bidder's Name: Valley Air Inc. / Logan Corporation

Address: P.O. Box 6516 Charleston, WV 25362

Telephone Number: (304) 345-2851 (800) 435-9959

Years Bidder has been registered to do business with the State of West Virginia: 20 YRS.

Years Company has been an authorized dealer for proposed unit: 20 YRS.

X4.2 DELIVERY:

X4.2.1 Delivery date of completed representative unit: 45 Calendar Days After Date of Purchase Agreement

X4.2.2 Delivery date of balance of completed units: 90 Calendar Days After Date of Purchase Agreement

X5.0 AWARD CRITERIA:

X5.1	Prices for units in quantities of:	1-5	<u>15,596.00</u>	per unit
		6-10	<u>15,596.00</u>	per unit

X6.0 SPECIFICATIONS - GENERAL

X6.1 Manufacturer, model, series, and date of manufacture of proposed unit:

Sullair 210HDPQ-JD

Is descriptive literature, fully describing proposed unit attached to your bid?  YES  NO

If not, why? \_\_\_\_\_

X6.2 Will the required number of service/completed parts list/manuals, and/or CD Rom be delivered to the Equipment Division at Buckhannon upon completion of delivery of total units?  YES  NO

Will the required Equipment Preventive Maintenance for (Section X6.2 of Bidders Evaluation Report) be provided upon inspection of the pilot unit?  YES  NO

\* Information provided upon receipt of order.

X6.2  
2-10-00

EQUIPMENT PREVENTATIVE MAINTENANCE QUESTIONNAIRE

THIS FORM MUST BE COMPLETED IN ITS ENTIRETY BY SUCCESSFUL BIDDER OR MANUFACTURER'S TECHNICAL REPRESENTATIVE PRIOR TO DELIVERY OF PILOT MODEL TO THE WVDOH

DESCRIPTION: Air Compressor MAKE: Sullair

MODEL# 210HDPO-JD YEAR: 2006 PURCHASE AMOUNT: \_\_\_\_\_

ENGINE: MAKE: \_\_\_\_\_ MODEL: \_\_\_\_\_ FUEL TYPE: \_\_\_\_\_

HORSEPOWER: \_\_\_\_\_ CYLINDER: \_\_\_\_\_ ENGINE SERIAL: \_\_\_\_\_

COOLING SYSTEM CAPACITY: \_\_\_\_\_

BELTS: DESCRIPTION: \_\_\_\_\_ PART NUMBERS: \_\_\_\_\_  
\_\_\_\_\_  
\_\_\_\_\_

GVW: \_\_\_\_\_ AXLE CAPACITY: FRONT: \_\_\_\_\_ REAR: \_\_\_\_\_

TIRES: FRONT MAKE & SIZE: \_\_\_\_\_

REAR MAKE & SIZE: \_\_\_\_\_

DIMENSIONS OF UNIT: LENGTH: \_\_\_\_\_ WIDTH: \_\_\_\_\_ HEIGHT: \_\_\_\_\_

VENDOR CONTACT PERSON: \_\_\_\_\_ PHONE: \_\_\_\_\_

PARTS:

BATTERY MAKE: \_\_\_\_\_ MODEL: \_\_\_\_\_ CCA: \_\_\_\_\_

TOP OR SIDE POST: \_\_\_\_\_ DIMENSIONS: LENGTH \_\_\_\_\_ WIDTH \_\_\_\_\_ HEIGHT \_\_\_\_\_

SPARK PLUGS OR FUEL INJECTORS MAKE: \_\_\_\_\_ PART # \_\_\_\_\_

FUEL PUMP OR INJECTION PUMP MAKE: \_\_\_\_\_ MODEL: \_\_\_\_\_

ALTERNATOR MAKE: \_\_\_\_\_ PART #: \_\_\_\_\_

STARTER MAKE: \_\_\_\_\_ PART #: \_\_\_\_\_

TURBO CHARGER MAKE: \_\_\_\_\_ PART #: \_\_\_\_\_

TRANS. MAKE: \_\_\_\_\_ MODEL: \_\_\_\_\_ AUTO/MANUAL: \_\_\_\_\_

HYDRAULIC PUMP MAKE: \_\_\_\_\_ MODEL: \_\_\_\_\_

FILTERS MAKE PART NO LUBRICANT MANUFACTURER TYPE

OIL \_\_\_\_\_ ENGINE \_\_\_\_\_  
AIR INNER \_\_\_\_\_ TRANSMISSION \_\_\_\_\_  
AIR OUTER \_\_\_\_\_ POWER STEERING \_\_\_\_\_  
FUEL PRIMARY \_\_\_\_\_ HYDRAULIC \_\_\_\_\_  
FUEL SECONDARY \_\_\_\_\_ DIFFERENTIALS \_\_\_\_\_  
COOLANT \_\_\_\_\_ BRAKE FLUID \_\_\_\_\_  
HYDRAULIC \_\_\_\_\_ COOLANT \_\_\_\_\_  
OTHER \_\_\_\_\_ OTHER \_\_\_\_\_

## X6.3 TRAINING:

Will training seminar be conducted on Preventive Maintenance, Operator and Mechanic Training?  YES  NO

Will you conduct training with each purchase order against this open end contract?  YES  NO

Will training be conducted within 2 working days from the delivery of the pilot unit on the individual purchase order?  YES  NO

If NO, explain time frame \_\_\_\_\_

Will an Operator's Manual be furnished to the Training Academy?  YES  NO

X6.4 If you are the successful vendor, will you furnish all training aids, i.e., videos, projectors, required in conducting the training?  YES  NO

X6.4.1 Will all manuals, booklets, etc explaining preventive maintenance, operator procedures, and service schedule be delivered with each unit?  YES  NO

If NO, explain \_\_\_\_\_

## X6.5 WARRANTY AND SERVICE POLICY:

Will the warranty and service you provide comply with all areas as stated in Section 6.5 of specifications.  YES  NO

Is warranty literature attached?  YES  NO

X65 WARRANTY AND SERVICE POLICY QUESTIONNAIRE

THIS FORM MUST BE COMPLETED IN ITS ENTIRETY BY THE SUCCESSFUL BIDDER OR MANUFACTURERS TECHNICAL REPRESENTATIVE PRIOR TO DELIVERY OF PILOT MODEL TO THE WVDOH (If additional lines are needed, make copies of form.)

1 Define the terms of the standard warranty. If not offered, so state. (Attach copy)

See copy of attached warranty statement

2. Define warranty service to be performed at DOH facilities and warranty service to be performed at manufacturer's representative facility List name and location of manufacturer's representative.

Nonintrusive repairs will be done at the WVDOH facility.  
Intrusive repairs will be done at the Valley Air Inc. shop.

3. List locations for parts inventories that are within the State of West Virginia Also, list availability levels, if known

Valley Air Inc. 3000 Edens Fork Road Charleston, WV 25312

4. During the term of warranty, list the guarantee discount to manufacturer's published list price for parts that bidder will sell the parts to owner.

- A. Terms: Net 30      Manufacturer's published list price less: 0 % discount
- B. Terms: Net 60      Manufacturer's published list price less: 0 % discount
- C. Terms: Net 90      Manufacturer's published list price less: 0 % discount

5. During the term of warranty, will all manufacturers or engineering improvements be submitted to Division of Highways? X YES      NO

6. During the term of warranty, list the guaranteed rates charged for repair to the unit.

- A. Shop Rate                      \$ 55.00 per mechanic hour
- B. Travel Time Charge            \$ 42.00 per mechanic hour  
(Specify if one-way)            \_\_\_\_\_; port to port X
- C. Mileage Charge                \$ 1.50 per vehicle mile  
(Specify if one-way                \_\_\_\_\_; port to port X
- D. Field Mechanic Rate            \$ 79.00 per mechanic hour

E. Specify period of time that prices are in effect: 09/01/06 thru 09/01/07

F. Surcharge for miscellaneous items: 0 %

## X6.6 EVALUATION COMMITTEE REQUIREMENTS:

Is all component specifications, product literature, component models provided for Evaluation Committee bid determination?  YES  NO

X6.7 Will all parts, equipment, accessories, material, design and performance characteristics not specified herein, but which are necessary to provide a complete unit, be furnished with the unit and conform in strength, quality of material, and quality of workmanship to those which are advertised and provided to the market in general by the unit industry?  YES  NO

X6.7.1 Are all parts and accessories adequate and regularly supplied as standard to be included except those which may be duplications of specifications herein, and except these by specification are not to be furnished?  YES  NO

X6.7.2 Are all standard safety features that are required by Federal and State statutes of law included?  YES  NO

## X7.0 SPECIFICATIONS OF THE QUOTED UNIT:

The bidder should complete the following schedule in order for the Division to compare the actual bid unit to the specifications. Should the bidder except a requirement, then such exception may be only on the basis that such feature is not offered by the manufacturer. The Division will have the sole discretion as to whether the bidder's substitution meets the requirements of the specification

Manufacturer: Sullair Model: 210HDPQ-JD

## X7.1 Compressor:

X7.1.1 Type: Rotary Screw

X7.1.1.1 Is unit self-contained, fully enclosed HD portable air compressor?  YES  NO

X7.1.2 Free Air Capacity: 210 CFM

X7.1.3 Type of lubrication for sealing and cooling of pump? Pressurized Oil

X7.1.4 Is oil filter the replaceable element  or spin-on full flow type  ?

X7.1.5 Is air intake filter dry type with maintenance signal?  YES  NO

X7.1.6 Are bearings anti-friction type and heaviest duty offered?  YES  NO

X7.2 Is air receiver ASME code construction?  YES  NO  
Working pressure 200 PSIG

X7.2.1 Air receiver capacity 1.43 cubic feet with safety valve and two (2) 3/4" service valves (universal type) X YES      NO

X7.2.2 Is discharge line fitted with an automatic discharge moisture trap and located between air receiver and service valve: X YES      NO

X7.2.3 Does unit have two (2) discharge line lubricators of one (1) quart each to each outlet, fitted and easily accessible? X YES      NO

X7.3 Engine:

X7.3.1 Type: Diesel

How is engine cooled? Fan and engine coolant fluid

X7.3.1.1 Unit BHP 82 at continuous rated speed of 2,500 RPM

X7.3.2 Electrical system equipped with 12 volt and heaviest duty offered? X YES      NO

X7.3.3 Fuel tank capacity 35 US gallons

X7.3.4 Is rain cap provided to protect engine and muffler? X YES      NO

X7.4 Is cooling system of sufficient capacity to allow engine and compressor to operate at rated air delivery and pressure continuously? X YES      NO

X7.4.1 Engine coolant rated at -32 degrees F

X7.5 Safety Devices and Instrumentation:

X7.5.1 Does unit have automatic blow-down valve? X YES      NO

X7.5.2 Does engine shut down by high discharge air temperature, low engine oil pressure and high engine temperature? X YES      NO

X7.5.3 Does unit have excess air flow safety valve and minimum pressure valve? X YES      NO

X7.5.4 Are the following gauges located in units instrument panel:

X7.5.4.1 Tachometer, engine RPM X YES      NO

X7.5.4.2 Ammeter or Voltmeter X YES      NO

X7.5.4.3 Engine temperature gauge X YES      NO



- X7.5.4.4 Engine oil pressure gauge  YES  NO
- X7.5.4.5 Discharge air pressure gauge  YES  NO
- X7.5.4.6 Fuel gauge  YES  NO
- X7.5.4.7 Hour meter  YES  NO
- X7.6 Are start and stop controls located on control panel?  YES  NO
- X7.7 Are all operation, maintenance and instruction decals located in a conspicuous place near controls?  YES  NO
- X7.8 Are controls the 0-100% demand type/controlling engine speed/intake of air compressor?  YES  NO
- X7.9 Accessories:
- X7.9.1 Does unit have service drain valve?  YES  NO
- X7.9.2 Is vandalism protection kit included?  YES  NO
- X7.9.3 Are lockable tool boxes included?  YES  NO
- X7.9.4 Does each unit have one (1) set of replacement filters for compressor air and lube oil and engine air, fuel and lube oil included with delivery?  YES  NO
- X7.9.5 Lifting bail, single point?  YES  NO
- X7.9.6 Are twin hose reels capable of holding 50 foot' x 1 inch O.D. hose?  YES  NO
- X7.10 Is compressor mounted on a two (2) wheeled type towing trailer?  YES  NO
- X7.10.1 Is engine/compressor frame mounted in a manner to minimize vibration?  YES  NO
- X7.10.2 Is suspension sufficient strength/handling of unit at top speed of 55 MPH?  YES  NO
- X7.10.3 Does trailer have retractable, swivel type third wheel?  YES  NO
- \* X7.10.4 Tire size F78 X 15 Tread Type Highway Load Range C  
Is wheel drop center, 7" wide?  YES  NO
- X7.10.5 Does hub have trailer wheel bearing protector?  YES  NO  
Manufacturer: Axis

X7.10 6 Does unit have draw bar with pintle eye and safety chains?  YES  NO

\* X7 10 7 Does trailer have stop lights, tail lights, directional indicators, (LED type) license plate light and license plate bracket?  YES  NO

X7.10.8 Male plug for towing vehicle specify: Cole-Hersee

X7 10 9 Does trailer meet or exceed all applicable West Virginia Department of Motor Vehicles Codes, and is towable at speeds up to 55 MPH?  YES  NO

X7 11 Paint: Describe proposed method of painting and striping the unit:

Unit to be painted over galvanized steel

Powder coated manufacturer color with Federal White as specified.

Is a sample of proposed white paint attached to bid?  YES  NO  
If no, when will sample be submitted: \_\_\_\_\_

X7 12 Does unit meet or exceed the OSHA of 1970" and/or subsequent changes?  YES  NO

X7 13 Does unit conform to the advertising guidelines?  YES  NO



State of West Virginia  
 Department of Administration  
 Purchasing Division  
 2019 Washington Street East  
 Post Office Box 50130  
 Charleston, WV 25305-0130

# Request for Quotation

RFO NUMBER  
**707EC004**

PAGE  
**1**

ADDRESS CORRESPONDENCE TO ATTENTION OF:  
**JOHN JOHNSTON**  
**304-558-2402**

VENDOR

\*709054056      304-345-2851  
 VALLEY AIR INC  
 PO BOX 6516  
 CHARLESTON WV 25362

SHIP TO

DIVISION OF HIGHWAYS  
 EQUIPMENT DIVISION  
 ROUTE 33  
 BRUSHY FORK ROAD  
 BUCKHANNON, WV  
 26201      304-472-1750

DATE PRINTED <b>08/27/2006</b>	TERMS OF SALE <b>Net 30 Days</b>	SHIP VIA <b>Motor Truck</b>	FOB. <b>Buckhannon, WV</b>	FREIGHT TERMS <b>Prepaid</b>
BID OPENING DATE: <b>09/06/2006</b>		BID OPENING TIME <b>01:30PM</b>		

LINE	QUANTITY	UOP	CAT NO	ITEM NUMBER	UNIT PRICE	AMOUNT
<b>ADDENDUM NO. 1</b>						
CHANGES TO THE SPECIFICATIONS PER THE ATTACHED.						
BID OPENING DATE AND TIME REMAINS THE SAME.						
NO OTHER CHANGES.						
0001	1	EA		025-50		15,596.00
				185 CFM AIR COMPRESSOR/PORTABLE Sullair 210HDPQ-JD		
***** THIS IS THE END OF RFQ 707EC004 ***** TOTAL:						15,596.00

SEE REVERSE SIDE FOR TERMS AND CONDITIONS

SIGNATURE  TELEPHONE (800) 435-9959 DATE 09/05/06  
 TITLE Sales Representative FEIN 55-065-9314-001 ADDRESS CHANGES TO BE NOTED ABOVE

WHEN RESPONDING TO RFQ, INSERT NAME AND ADDRESS IN SPACE ABOVE LABELED 'VENDOR'

ADDENDUM #1  
707EC004

OPEN END CONTRACT  
185 CFM AIR COMPRESSOR/PORTABLE

CHANGES TO SPECIFICATIONS:

FROM:

4.2 DELIVERY (2<sup>nd</sup> Paragraph – Line 2)

Delivery is preferred within 45 days

TO:

4.2 DELIVERY (2<sup>nd</sup> Paragraph – Line 2)

Delivery is preferred within 90 days.

FROM:

7.9.1 Service drain valve

TO:

7.9.1 Air separator service drain valve

ADDENDUM #1  
707EC004

OPEN END CONTRACT  
185 CFM AIR COMPRESSOR/PORTABLE

CHANGES TO BIDDERS EVALUATION REPORT:

X4 2 DELIVERY            No change required

FROM:

X7 9 1 - Does unit have service drain valve              x   YES        NO

TO:

X7 9 1 - Does unit have air separator service drain valve              x   YES        NO

# SIGN IN SHEET

Page 1 of     

RF# 707ES004  
Date 8-24-06

Firm & Representative Name:

Mailing Address:

Phone&Fax#:

1. <u>UNTRACOM</u>	<u>P.O. BOX 473</u>	<u>P 346-5300</u>
<u>GARY GRADY</u>	<u>CHARLESTON WV 25322</u>	<u>F 346-5305</u>

2. <u>Uniontown Ind. FC</u>	<u>100 College Dr.</u>	<u>724-437-1578</u>
<u>MIKE CLOSER</u>		

3. <u>Vancey Air Inc, Logan Co</u>	<u>P.O. Box 6516</u>	<u>304/345-2851</u>
<u>JAM PAULEY</u>	<u>CHARLESTON WV 25362</u>	<u>304/345-2856</u>

4. <u>Anderson Equipment</u>	<u>2 Roskin Dr.</u>	<u>304-366-3079</u>
<u>Brian Cantrell</u>	<u>Fairmont, WV 26554</u>	<u>304-366-7214</u>

5. <u>Karen Cochran</u>	<u>DOT</u>	
<u>Don Weese</u>		

6. _____	_____	_____
_____	_____	_____

7. _____	_____	_____
_____	_____	_____

Please print or write legibly!  
Your Fax # is essential to contact you timely!

## STATEMENT OF WARRANTY

### Portable Air Compressors

Sullair Corporation ("Sullair") warrants that, under normal use and service, if properly stored, handled, installed, operated and maintained, its portable air compressors ("Compressors") shall for a period of twelve (12) months ("Warranty Period") (1) beginning at machine start-up if the registration card is returned within ten (10) days after start-up and the start up occurs within twelve (12) months after shipment by Sullair from the factory, or (2) if not, beginning thirty (30) days after shipment by Sullair from the factory, be free of defects in materials and workmanship, under normal use and service and that its rotary screw air-end ("Air-end") utilized in Compressors, excluding air-end shaft seals which are included with Compressors, shall, for a period of twenty-four (24) months ("Warranty Period"), (1) beginning at machine start-up if the registration card is returned within ten (10) days after start-up and the start up occurs within twelve (12) months after shipment by Sullair from the factory, or (2) if not, beginning thirty (30) days after shipment by Sullair from the factory, be free of defects in materials and workmanship, under normal use and service. All Sullair Compressors manufactured after January 1, 1997, that are continuously charged with Sullair AWF Fluid and have been regularly maintained using Sullair filters shall have a warranty period of sixty (60) months or 10,000 hours, whichever occurs first, beginning at conditions (1) or (2) stated previously for the Air-end. Should any such defect become apparent within such time, and written notice of each and every such defect is promptly provided to Sullair, and Sullair reasonably determines that any such Product is defective in material or workmanship, Sullair will at its option, replace or repair such Product. Disassembly of the compressor Air-end will void this warranty and the air-end exchange policy. This warranty does not apply to any Air-end damaged by accident, misuse or negligence. Sullair's obligation with respect to such Product shall be limited to repair or replacement, F.O.B. Sullair's place of business, without any further expense to Sullair, and except as expressly provided herein, Sullair shall not in any event be liable for any other labor, transportation, installation, adjustment or other expenses which may arise in connection with such Product. Any misuse or abuse of the Product(s) voids this limited warranty.

This Sullair warranty does not extend to Products not assembled by Sullair. As to Products assembled by others including the driver (whether engine, turbine or electric motor), Purchaser shall be entitled to proceed only upon the terms of that particular manufacturer's warranty. The Sullair warranty does not apply to defects in materials provided by Purchaser or design stipulated by Purchaser.

Used Products, and Products not assembled by Sullair are sold AS IS with no representation or warranty, and ALL WARRANTIES OF QUALITY, WRITTEN, ORAL OR IMPLIED, other than may be expressly agreed to by Sullair in writing, INCLUDING WITHOUT LIMITATION WARRANTIES OF MERCHANTABILITY OR FITNESS, ARE HEREBY DISCLAIMED.

IN NO EVENT SHALL SULLAIR BE LIABLE FOR SPECIAL, INDIRECT, INCIDENTAL OR CONSEQUENTIAL DAMAGES however arising whether in warranty, strict liability, tort, negligence or otherwise, including but not limited to loss of profits or revenue, loss of total or partial use of the Products, facilities or services, downtime costs, or claims of Purchase for such or other damages whether on account of Products furnished hereunder or delays in delivery thereof or services performed upon or with respect to such Products. Sullair's liability on any claim whether in warranty, strict liability, tort, negligence or otherwise for any loss or damage arising out of, connected with, or resulting from this warranty or the performance or breach thereof, or from the design, manufacture, sale, delivery, resale, repair, replacement, installation, technical direction of installation, inspection, servicing, operation or use of any Product covered by or furnished under this warranty shall in no case exceed the purchase price allowable to the Product or part thereof which give rise to the claim. Notice of claims against Sullair hereunder for any reason, including breach of warranty, must be made to Sullair in writing within forty-eight (48) hours of discovery to afford Sullair an opportunity to make a prompt investigation of surrounding facts and mitigate any damage which might ensue, should it be determined to be Sullair's responsibility. Failure to give such notice to Sullair shall constitute a waiver by Purchaser of any right later to assert such a claim. Any cause of action against Sullair arising out of or relating to the warranty or the performance hereof shall expire unless brought within one (1) year of the time of accrual thereof.

THE FOREGOING LIMITED WARRANTY IS EXCLUSIVE AND IN LIEU OF ALL OTHER WARRANTIES, EXPRESSED OR IMPLIED, INCLUDING BUT NOT LIMITED TO ANY WARRANTY OF MERCHANTABILITY OR FITNESS FOR A PARTICULAR PURPOSE.



**SULLAIR CORPORATION**  
MICHIGAN CITY, INDIANA 46360

(PLEASE PRINT)

Model No. _____	Serial No. _____
Firm Name _____	
Address _____	
STREET ADDRESS	CITY STATE ZIP
Type of Manufacturing _____	Product Application _____
Telephone No. (_____) _____	Person to Contact _____
Equipment Purchased From _____	City State Zip Code _____
Start-Up Date _____	
Month Day Year	

Model No. _____	Serial No. _____
Machine Integrity:      Poor      Fair      Good	
* GENERAL APPEARANCE <input type="checkbox"/> <input type="checkbox"/> <input type="checkbox"/>	
* LUBRICATION SYSTEM <input type="checkbox"/> <input type="checkbox"/> <input type="checkbox"/>	Have you purchased Sullair before? Yes <input type="checkbox"/> No <input type="checkbox"/>
* ELECTRICAL SYSTEM <input type="checkbox"/> <input type="checkbox"/> <input type="checkbox"/>	

Customer Name \_\_\_\_\_

Comments \_\_\_\_\_

This Card Registers You As A Sullair Compressor Owner.



**VALLEY AIR**  
3000 EDENS FORK ROAD  
P. O. BOX 6516  
CHARLESTON, WV 25362-0516  
PHONE: (304) 345-2851  
1-800-435-9959  
FAX: (304) 345-2856  
[www.logancorp.com](http://www.logancorp.com)

Purchasing Division  
2019 Washington Street East  
P.O. Box 50130  
Charleston, WV 25305

WVDOH Buckhannon

RFQ # 707EC004

**\* EXCEPTIONS TO SPECIFICATIONS**

X7.10.4      Tire Size F78 X 15  
                  Wheel Drop Center 5"

X7.10.7      Lights are not LED



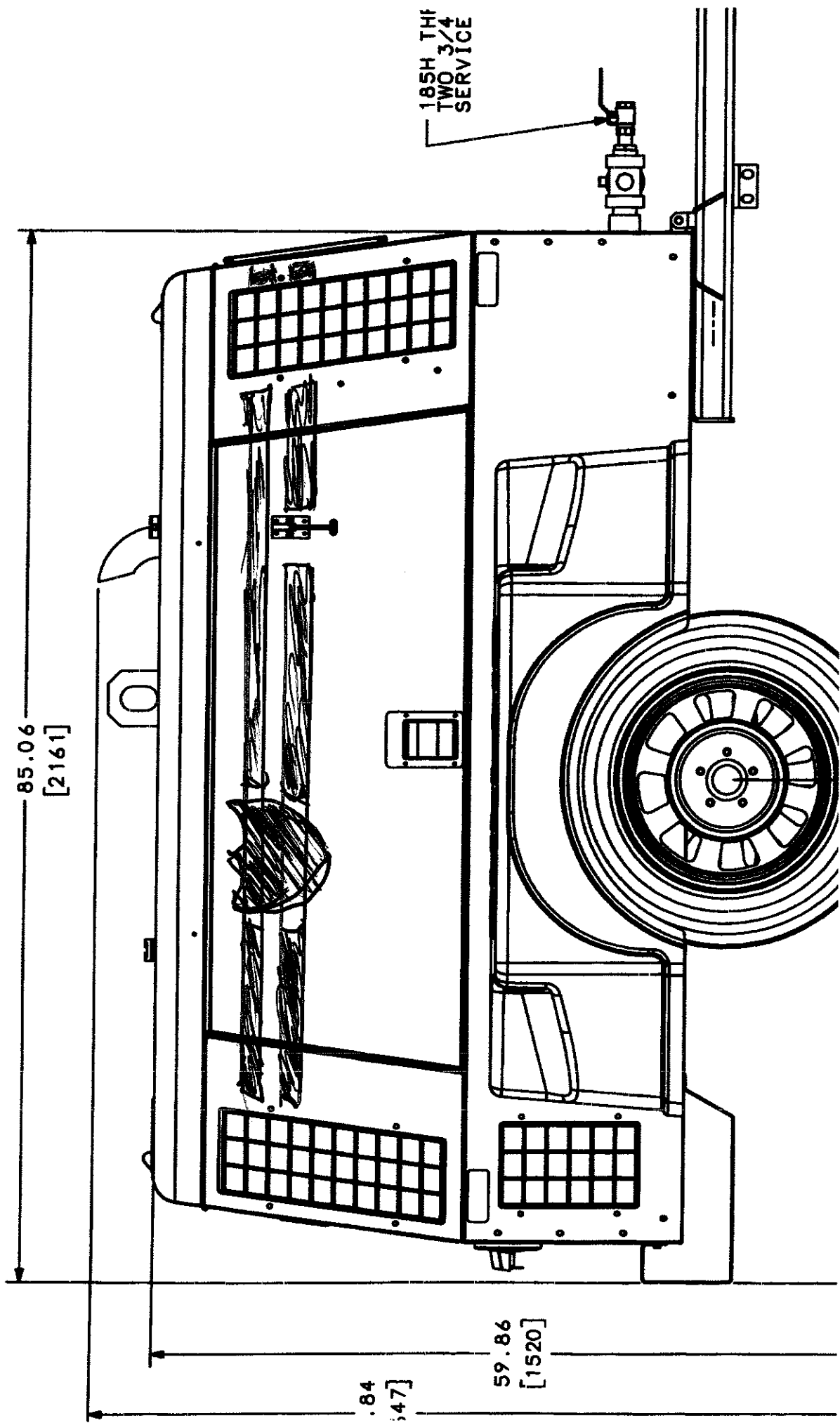

185H THF  
TWO 3/4  
SERVICE

85.06  
[2161]

.84  
[47]

59.86  
[1520]

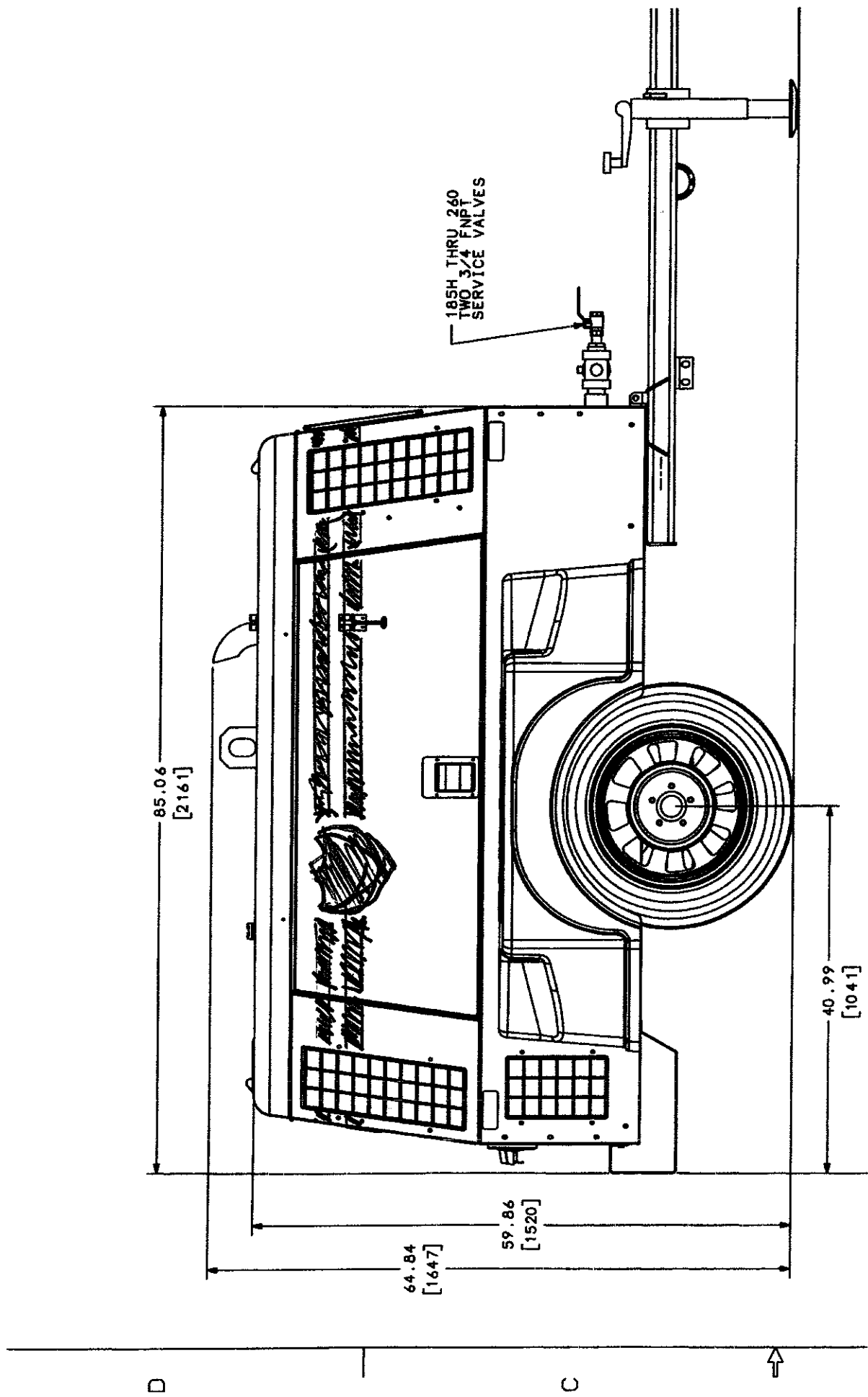

RADIATOR FILL ACCESS

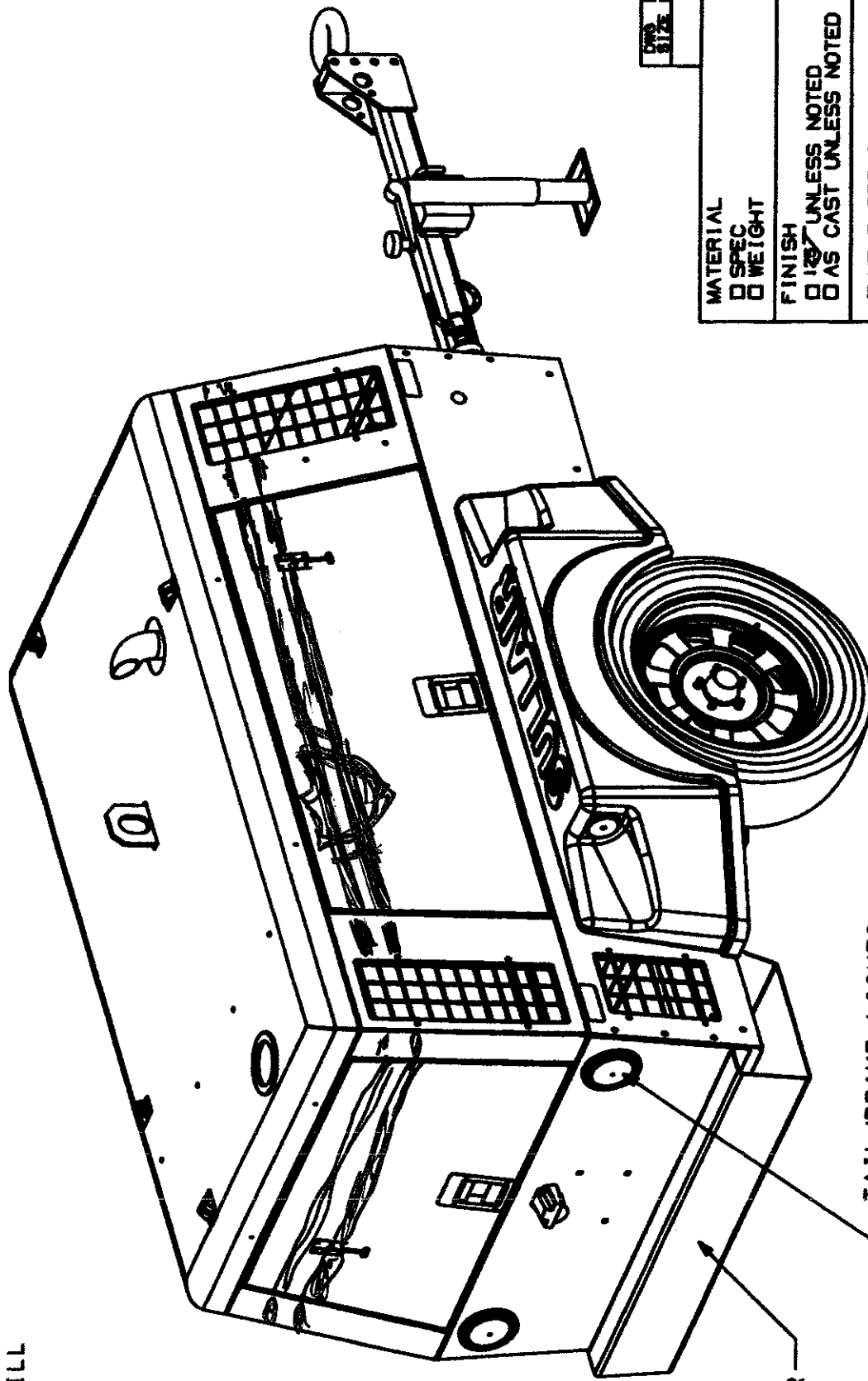

BUMPER

TAIL/BRAKE LIGHTS

QMS ITEM NO.

MATERIAL	THIS PART
<input type="checkbox"/> SPEC	RATION
<input type="checkbox"/> WEIGHT	COPIES
FINISH	OTHER
<input type="checkbox"/> 1237 UNLESS NOTED	THE CC
<input type="checkbox"/> AS CAST UNLESS NOTED	CORPOR
<input type="checkbox"/> HEAT TREAT	FORM 0
<input type="checkbox"/> HARDNESS	APPR
<input type="checkbox"/> PAINT PER SULLAIR	CHECK
<input type="checkbox"/> SPEC. NO. -----	DRAW
<input type="checkbox"/> OTHER (SPEC.) -----	

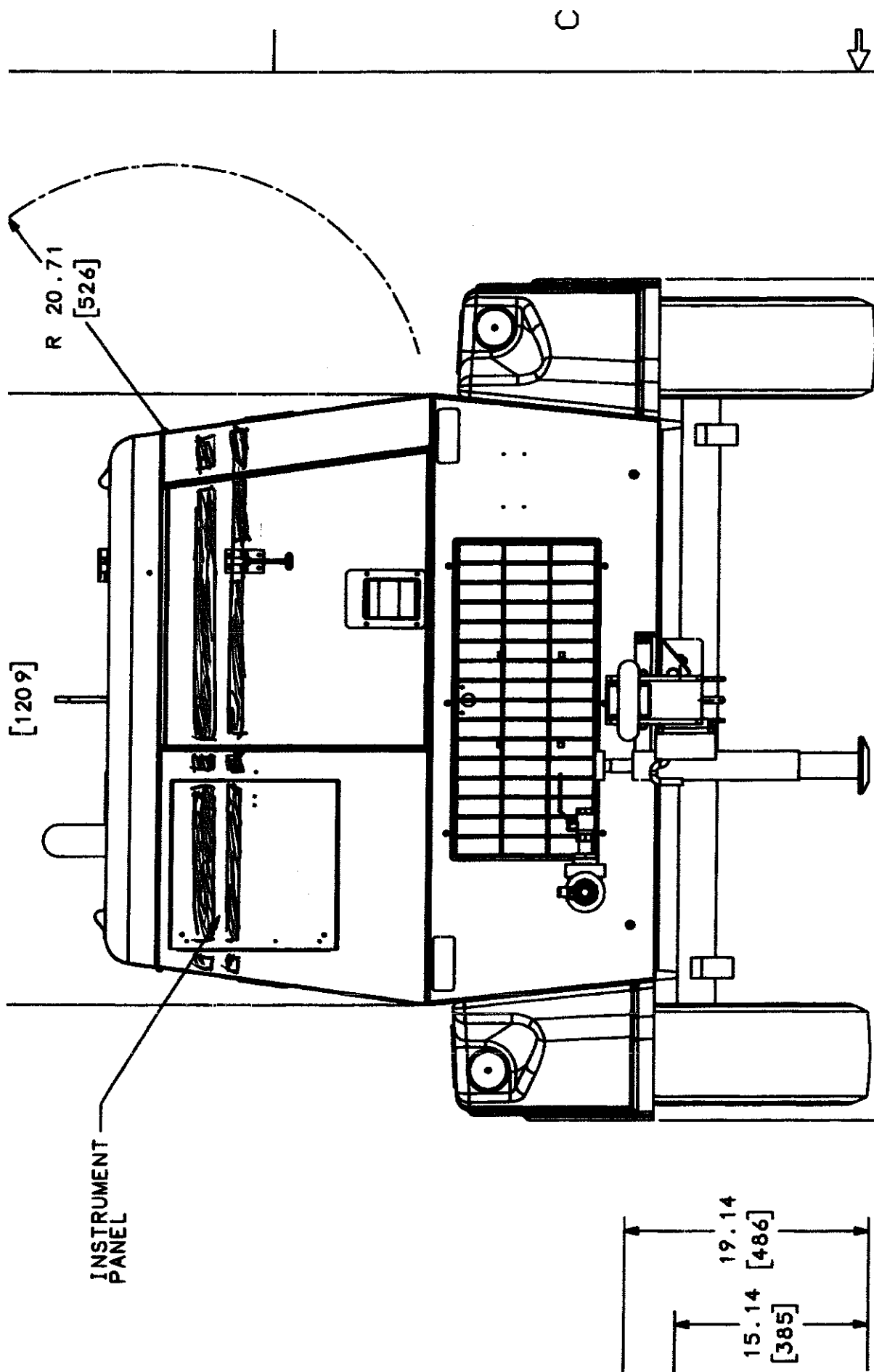

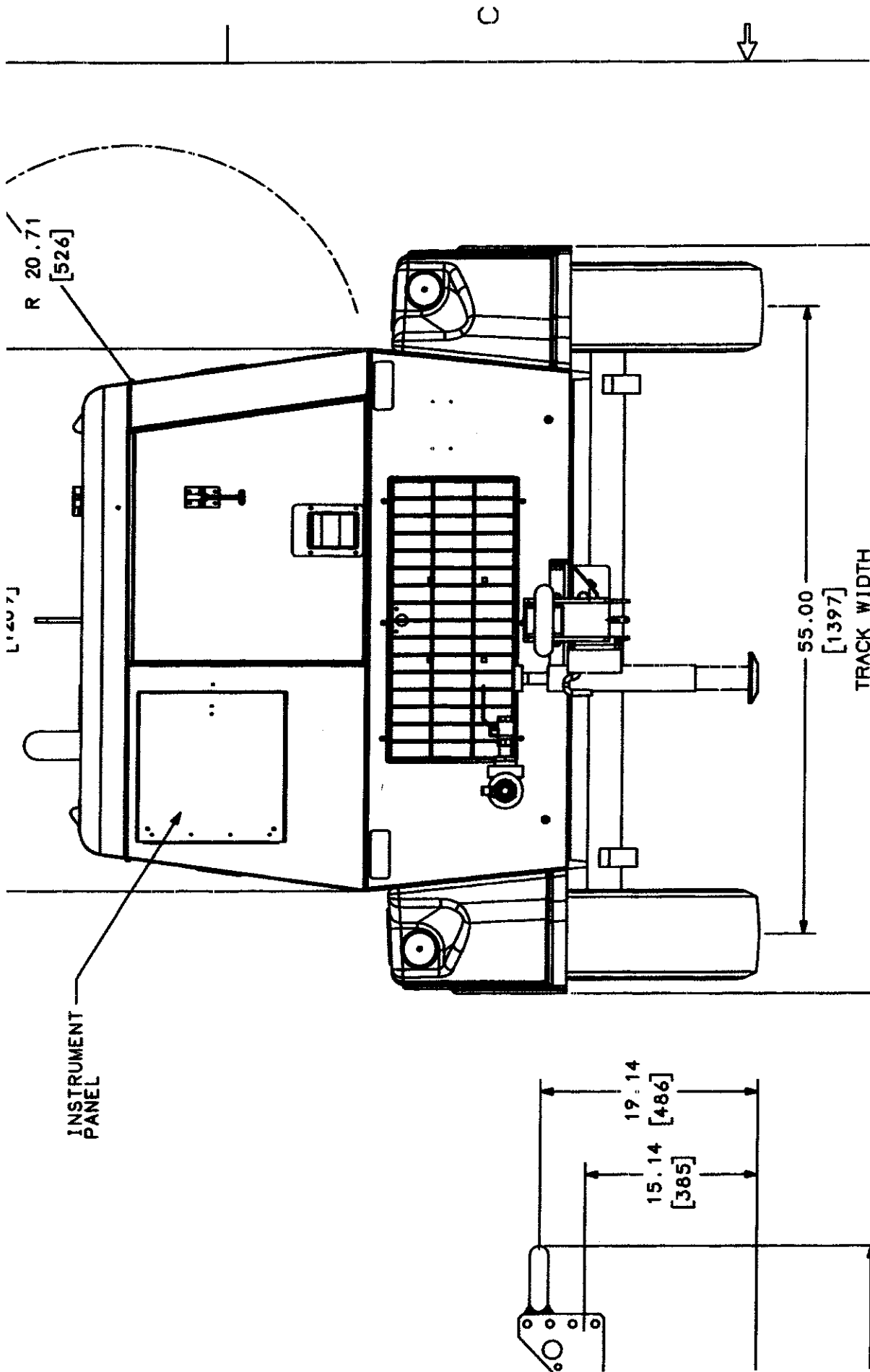

# A F F I D A V I T

**West Virginia Code §5A-3-10a states:**

No contract or renewal of any contract may be awarded by the state or any of its political subdivisions to any vendor or prospective vendor when the vendor or prospective vendor or a related party to the vendor or prospective vendor is a debtor and the debt owned is an amount greater than one thousand dollars in the aggregate

**DEFINITIONS:**

"Debt" means any assessment, premium, penalty, fine, tax or other amount of money owed to the state or any of its political subdivisions because of a judgment, fine, permit violation, license assessment, defaulted workers' compensation premium, penalty or other assessment presently delinquent or due and required to be paid to the state or any of its political subdivisions, including any interest or additional penalties accrued thereon

"Debtor" means any individual, corporation, partnership, association, limited liability company or any other form or business association owing a debt to the state or any of its political subdivisions

"Political subdivision" means any county commission; municipality; county board of education; any instrumentality established by a county or municipality; any separate corporation or instrumentality established by one or more counties or municipalities, as permitted by law; or any public body charged by law with the performance of a government function or whose jurisdiction is coextensive with one or more counties or municipalities

"Related party" means a party, whether an individual, corporation, partnership, association, limited liability company or any other form or business association or other entity whatsoever, related to any vendor by blood, marriage, ownership or contract through which the party has a relationship of ownership or other interest with the vendor so that the party will actually or by effect receive or control a portion of the benefit, profit or other consideration from performance of a vendor contract with the party receiving an amount that meets or exceeds five percent of the total contract amount

**EXCEPTION:**

The prohibition of this section does not apply where a vendor has contested any tax administered pursuant to chapter eleven of this code, workers' compensation premium, permit fee or environmental fee or assessment and the matter has not become final or where the vendor has entered into a payment plan or agreement and the vendor is not in default of any of the provisions of such plan or agreement.

**LICENSING:**

The vendor must be licensed in accordance with any and all state requirements to do business with the state of West Virginia

**CONFIDENTIALITY:**

The vendor agrees that he or she will not disclose to anyone, directly or indirectly, any such personally identifiable information or other confidential information gained from the agency, unless the individual who is the subject of the information consents to the disclosure in writing or the disclosure is made pursuant to the agency's policies, procedures and rules. Vendors should visit [www.state.wv.us/admin/purchase/privacy](http://www.state.wv.us/admin/purchase/privacy) for the Notice of Agency Confidentiality Policies

Under penalty of law for false swearing (West Virginia Code, §61-5-3), it is hereby certified that the vendor acknowledges the information in this said affidavit and are in compliance with the requirements as stated.

Vendor's Name: Valley Air Inc. / Logan Corporation

Authorized Signature:  Date: 09/05/06