



State of West Virginia
 Department of Administration
 Purchasing Division
 2019 Washington Street East
 Post Office Box 50130
 Charleston, WV 25305-0130

Request for Quotation

RFQ NUMBER
0870204

PAGE
1

ADDRESS CORRESPONDENCE TO ATTENTION OF
JOHN JOHNSTON 304-558-2402

VENDOR

*709060129 304-766-6601
 CHARLESTON STEEL
 PO BOX 547 511 28TH STREET
 DUNBAR WV 25064

SHIP TO

DIVISION OF HIGHWAYS
 DISTRICT EIGHT
 P.O. BOX 1516
 US 219, NORTH PARSONS ROAD
 ELKINS, WV
 26241-1516 304-557-0215

Q07-043

DATE PRINTED	TERMS OF SALE	SHIP VIA	F.O.B.	FREIGHT TERMS
01/30/2007				

BID OPENING DATE: 02/21/2007 BID OPENING TIME 01:30PM

LINE	QUANTITY	UOP	CAT NO.	ITEM NUMBER	UNIT PRICE	AMOUNT
0001	1	LB		570-84		
STRUCTURAL STEEL TO PROVIDE STRUCTURAL STEEL FOR THE WOODS RUN BRIDGE, PROJECT NO. S338-1-15.34. NOTE: BID UNIT PRICES MUST BE QUOTED AS PRICE PER POUND. SEE ATTACHED VENDOR PREFERENCE CERTIFICATE CERTIFICATION AND APPLICATION* IS HEREBY MADE FOR PREFERENCE IN ACCORDANCE WITH WEST VIRGINIA CODE, 5A-3-37 (DOES NOT APPLY TO CONSTRUCTION CONTRACTS). A. APPLICATION IS MADE FOR 2.5% PREFERENCE FOR THE REASON CHECKED: <input type="checkbox"/> BIDDER IS AN INDIVIDUAL RESIDENT VENDOR AND HAS RESIDED CONTINUOUSLY IN WEST VIRGINIA FOR FOUR (4) YEARS IMMEDIATELY PRECEDING THE DATE OF THIS CERTIFICATION; OR <input checked="" type="checkbox"/> BIDDER IS A PARTNERSHIP, ASSOCIATION OR CORPORA- TION RESIDENT VENDOR AND HAS MAINTAINED ITS HEAD- QUARTERS OR PRINCIPAL PLACE OF BUSINESS CONTINUOUSLY IN WEST VIRGINIA FOR FOUR (4) YEARS IMMEDIATELY PRECEDING THE DATE OF THIS CERTIFICATION; OR 80% OF THE OWNERSHIP INTEREST OF BIDDER IS HELD BY ANOTHER INDIVIDUAL,						

RECEIVED
 2007 FEB 21 A 9 26
 PURCHASING DIVISION
 STATE OF WV

SEE REVERSE SIDE FOR TERMS AND CONDITIONS

SIGNATURE <i>Dennis Nicholas</i>	TELEPHONE 304-766-6607	DATE 2/20/07
TITLE SALES	FEIN 20-5496272	ADDRESS CHANGES TO BE NOTED ABOVE

WHEN RESPONDING TO RFQ, INSERT NAME AND ADDRESS IN SPACE ABOVE LABELED 'VENDOR'



State of West Virginia
 Department of Administration
 Purchasing Division
 2019 Washington Street East
 Post Office Box 50130
 Charleston, WV 25305-0130

Request for Quotation

RFQ NUMBER
0870204

PAGE
2

ADDRESS CORRESPONDENCE TO ATTENTION OF:
JOHN JOHNSTON 304-558-2402

VENDOR

*709060129 304-766-6601
 CHARLESTON STEEL
 PO BOX 547 511 28TH STREET
 DUNBAR WV 25064

SHIP TO

DIVISION OF HIGHWAYS
 DISTRICT EIGHT
 P.O. BOX 1516
 US 219, NORTH PARSONS ROAD
 ELKINS, WV
 26241-1516 304-557-0215

DATE PRINTED	TERMS OF SALE	SHIP VIA	F.O.B.	FREIGHT TERMS
01/30/2007				

BID OPENING DATE: 02/21/2007 BID OPENING TIME 01:30PM

LINE	QUANTITY	UOP	CAT NO	ITEM NUMBER	UNIT PRICE	AMOUNT
<p>PARTNERSHIP, ASSOCIATION OR CORPORATION RESIDENT VENDOR WHO HAS MAINTAINED ITS HEADQUARTERS OR PRINCIPAL PLACE OF BUSINESS CONTINUOUSLY IN WEST VIRGINIA FOR FOUR (4) YEARS IMMEDIATELY PRECEDING THE DATE OF THIS CERTIFICATION; OR</p> <p>() BIDDER IS A CORPORATION NONRESIDENT VENDOR WHICH HAS AN AFFILIATE OR SUBSIDIARY WHICH EMPLOYS A MINIMUM OF ONE HUNDRED STATE RESIDENTS AND WHICH HAS MAINTAINED ITS HEADQUARTERS OR PRINCIPAL PLACE OF BUSINESS WITHIN WEST VIRGINIA CONTINUOUSLY FOR THE FOUR (4) YEARS IMMEDIATELY PRECEDING THE DATE OF THIS CERTIFICATION.</p> <p>B. APPLICATION IS MADE FOR 2.5% PREFERENCE FOR THE REASON CHECKED:</p> <p>(X) BIDDER IS A RESIDENT VENDOR WHO CERTIFIES THAT, DURING THE LIFE OF THE CONTRACT, ON AVERAGE AT LEAST 75% OF THE EMPLOYEES WORKING ON THE PROJECT BEING BID ARE RESIDENTS OF WEST VIRGINIA WHO HAVE RESIDED IN THE STATE CONTINUOUSLY FOR THE TWO YEARS IMMEDIATELY PRECEDING SUBMISSION OF THIS BID;</p> <p>OR</p> <p>() BIDDER IS A NONRESIDENT VENDOR EMPLOYING A MINIMUM OF ONE HUNDRED STATE RESIDENTS OR IS A NONRESIDENT VENDOR WITH AN AFFILIATE OR SUBSIDIARY WHICH MAINTAINS ITS HEADQUARTERS OR PRINCIPAL PLACE OF BUSINESS WITHIN WEST VIRGINIA EMPLOYING A MINIMUM OF ONE HUNDRED STATE RESIDENTS WHO CERTIFIES THAT, DURING THE LIFE OF THE CONTRACT, ON AVERAGE AT LEAST 75% OF THE EMPLOYEES OR BIDDERS' AFFILIATE'S OR SUBSIDIARY'S EMPLOYEES ARE RESIDENTS OF WEST VIRGINIA WHO HAVE RESIDED IN THE STATE CONTINUOUSLY FOR THE TWO YEARS IMMEDIATELY PRECEDING SUBMISSION OF THIS BID.</p>						

SEE REVERSE SIDE FOR TERMS AND CONDITIONS

SIGNATURE <i>Dennis Nicholas</i>	DENNIS NICHOLAS	TELEPHONE 304-766-6607	DATE 2/20/07
TITLE SALES	FEIN 20-5496272	ADDRESS CHANGES TO BE NOTED ABOVE	

WHEN RESPONDING TO RFQ, INSERT NAME AND ADDRESS IN SPACE ABOVE LABELED 'VENDOR'



State of West Virginia
 Department of Administration
 Purchasing Division
 2019 Washington Street East
 Post Office Box 50130
 Charleston, WV 25305-0130

Request for Quotation

RFQ NUMBER
0870204

PAGE
3

ADDRESS CORRESPONDENCE TO ATTENTION OF:
JOHN JOHNSTON
304-558-2402

VENDOR

*709060129 304-766-6601
CHARLESTON STEEL
PO BOX 547 511 28TH STREET

DUNBAR WV 25064

SHIP TO

DIVISION OF HIGHWAYS
DISTRICT EIGHT
P.O. BOX 1516
US 219, NORTH PARSONS ROAD
ELKINS, WV
26241-1516 304-557-0215

DATE PRINTED	TERMS OF SALE	SHIP VIA	F.O.B.	FREIGHT TERMS
01/30/2007				

BID OPENING DATE: **02/21/2007** BID OPENING TIME **01:30PM**

LINE	QUANTITY	UOP	CAT NO.	ITEM NUMBER	UNIT PRICE	AMOUNT
<p>BIDDER UNDERSTANDS IF THE SECRETARY OF TAX & REVENUE DETERMINES THAT A BIDDER RECEIVING PREFERENCE HAS FAILED TO CONTINUE TO MEET THE REQUIREMENTS FOR SUCH PREFERENCE, THE SECRETARY MAY ORDER THE DIRECTOR OF PURCHASING TO: (A) RESCIND THE CONTRACT OR PURCHASE ORDER ISSUED; OR (B) ASSESS A PENALTY AGAINST SUCH BIDDER IN AN AMOUNT NOT TO EXCEED 5% OF THE BID AMOUNT AND THAT SUCH PENALTY WILL BE PAID TO THE CONTRACTING AGENCY OR DEDUCTED FROM ANY UNPAID BALANCE ON THE CONTRACT OR PURCHASE ORDER.</p> <p>BY SUBMISSION OF THIS CERTIFICATE, BIDDER AGREES TO DISCLOSE ANY REASONABLY REQUESTED INFORMATION TO THE PURCHASING DIVISION AND AUTHORIZES THE DEPARTMENT OF TAX AND REVENUE TO DISCLOSE TO THE DIRECTOR OF PURCHASING APPROPRIATE INFORMATION VERIFYING THAT BIDDER HAS PAID THE REQUIRED BUSINESS TAXES, PROVIDED THAT SUCH INFORMATION DOES NOT CONTAIN THE AMOUNTS OF TAXES PAID NOR ANY OTHER INFORMATION DEEMED BY THE TAX COMMISSIONER TO BE CONFIDENTIAL.</p> <p>UNDER PENALTY OF LAW FOR FALSE SWEARING (WEST VIRGINIA CODE 61-5-3), BIDDER HEREBY CERTIFIES THAT THIS CERTIFICATE IS TRUE AND ACCURATE IN ALL RESPECTS; AND THAT IF A CONTRACT IS ISSUED TO BIDDER AND IF ANYTHING CONTAINED WITHIN THIS CERTIFICATE CHANGES DURING THE TERM OF THE CONTRACT, BIDDER WILL NOTIFY THE PURCHASING DIVISION IN WRITING IMMEDIATELY.</p> <p>BIDDER: <u>CHARLESTON STEEL Co</u></p> <p>DATE: <u>2/20/07</u></p>						

SEE REVERSE SIDE FOR TERMS AND CONDITIONS

SIGNATURE <i>Dennis Nicholas</i> DENNIS NICHOLAS	TELEPHONE 304-766-6607	DATE 2/20/07
TITLE SALES	FEIN 20-5496272	ADDRESS CHANGES TO BE NOTED ABOVE

WHEN RESPONDING TO RFQ, INSERT NAME AND ADDRESS IN SPACE ABOVE LABELED 'VENDOR'



State of West Virginia
 Department of Administration
 Purchasing Division
 2019 Washington Street East
 Post Office Box 50130
 Charleston, WV 25305-0130

Request for Quotation

RFQ NUMBER
0870204

PAGE
4

ADDRESS CORRESPONDENCE TO ATTENTION OF
JOHN JOHNSTON 304-558-2402

VENDOR

*709060129 304-766-6601
 CHARLESTON STEEL
 PO BOX 547 511 28TH STREET
 DUNBAR WV 25064

SHIP TO

DIVISION OF HIGHWAYS
 DISTRICT EIGHT
 P.O. BOX 1516
 US 219, NORTH PARSONS ROAD
 ELKINS, WV
 26241-1516 304-557-0215

DATE PRINTED	TERMS OF SALE	SHIP VIA	F.O.B.	FREIGHT TERMS
01/30/2007				

BID OPENING DATE: **02/21/2007** BID OPENING TIME **01:30PM**

LINE	QUANTITY	UOP	CAT NO.	ITEM NUMBER	UNIT PRICE	AMOUNT
<p>SIGNED: <i>Dennis Nicholas</i></p> <p>TITLE: <i>Mgr. Warehouse Sales</i></p> <p>* CHECK ANY COMBINATION OF PREFERENCE CONSIDERATION(S) IN EITHER "A" OR "B", OR BOTH "A" AND "B" WHICH YOU ARE ENTITLED TO RECEIVE. YOU MAY REQUEST UP TO THE MAXIMUM 5% PREFERENCE FOR BOTH "A" AND "B". (REV. 12/00)</p> <p>NOTICE</p> <p>A SIGNED BID MUST BE SUBMITTED TO:</p> <p>DEPARTMENT OF ADMINISTRATION PURCHASING DIVISION BUILDING 15 2019 WASHINGTON STREET, EAST CHARLESTON, WV 25305-0130</p> <p>THE BID SHOULD CONTAIN THIS INFORMATION ON THE FACE OF THE ENVELOPE OR THE BID MAY NOT BE CONSIDERED:</p> <p>SEALED BID</p> <p>BUYER: 33</p> <p>RFQ. NO.: 0870204</p> <p>BID OPENING DATE AND TIME: 02/21/07</p>						

SEE REVERSE SIDE FOR TERMS AND CONDITIONS

SIGNATURE: <i>Dennis Nicholas</i>	TELEPHONE: 304-766-6607	DATE: 2/20/07
TITLE: SALES	FEIN: 20-5496272	ADDRESS CHANGES TO BE NOTED ABOVE

WHEN RESPONDING TO RFQ, INSERT NAME AND ADDRESS IN SPACE ABOVE LABELED 'VENDOR'

Item No.	Quantity	Description	Unit Price	Amount
1	19,150 lbs	W18x60, Galvanized W-Shaped Structural Steel, AASHTO M270, Grade 50. Ship: 10 pcs @ 31' -11" fabricated in accordance with Sketch # 1.	<u>1.18</u>	<u>22,597.⁰⁰</u>
2	1,656 lbs	C12x20.7, Galvanized Structural Steel Channel, AASHTO M270, Grade 50. Ship: 4 pcs @ 20' -0"	<u>1.20</u>	<u>1,987.²⁰</u>
3	1,024 lbs.	L 4" x 4" x 1/2" (12.8 #/LF) Galvanized Structural Steel Angle, AASHTO M270, Grade 50. Ship: 4 pcs. @ 20' -0"	<u>1.11</u>	<u>1,136.⁶⁴</u>
4	768 lbs	L 4" x 4" x 1/2" (12.8 #/LF) Galvanized Structural Steel Angle, AASHTO M270, Grade 50. Ship: 60 pcs @ 1' -0" fabricated in accordance with Sketch # 2.	<u>2.05</u>	<u>1,574.⁴⁰</u>
5	2,819 lbs.	6" x 6" x 1/2" Galvanized Structural Steel Tubing (35.24 #/LF) ASTM A500 Ship: 4 pcs. @ 20' -0"	<u>1.27</u>	<u>3,580.¹³</u>
6	612 lbs.	3/4" x 6" Galvanized Structural Steel Bar (15.3 #/LF) AASHTO M270, Grade 50. Ship: 4 pcs. @ 10' -0"	<u>1.42</u>	<u>869.⁰⁴</u>
7	2,560 lbs.	L 4" x 4" x 1/2" (12.8 #/LF) Structural Steel Angle, AASHTO M270, Grade 50. Ship: 10 pcs. @ 20' -0"	<u>.63</u>	<u>1,612.⁸⁰</u>
		TOTAL		<u>\$ 33,357.²¹</u>

Item No.	Quantity	Description	Unit Price	Amount
		<ol style="list-style-type: none">1. The above listed materials are to be delivered to the WVDOH, District Eight lot, located on US Route 219, approximately 1 mile north of Elkins WV2. The District Eight Storekeeper must be notified at (304) 637-0226 at least 48 hours in advance of delivery to provide necessary personnel and equipment for unloading.3. Delivery will only be accepted during normal working hours of 7:30am to 4:00pm, Monday - Friday.4. All galvanizing shall be in accordance with AASHTO MIII.5. Steel designated as AASHTO M270 shall conform to Section S4. Non-Fracture-Critical, Zone 2, toughness testing and requirements6. The project is scheduled for April, 2007.		

SCO No. 087-0204
Page No. 4 of 5
Sketch No. 1

32'-6 1/2"
32.5417
31'-11"

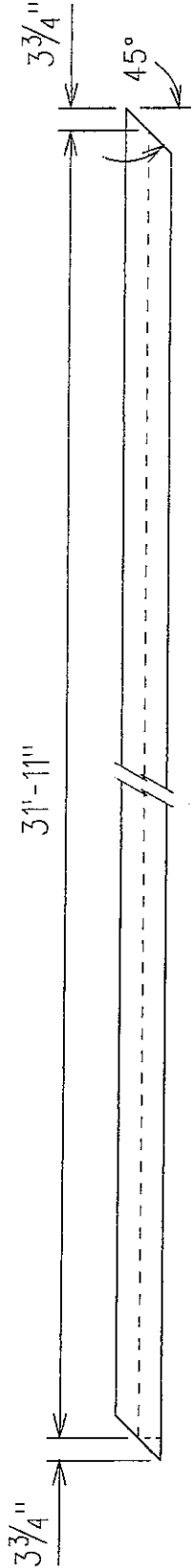

W18x60

7 1/2"

W. Va. Department of Transportation
Division of Highways, District 8
PO Box 1516
Elkins, WV 26241
RPO No. 087-0204
Page No. 5 of 5
Sketch No. 2

ALL HOLES $1\frac{3}{16}$ " DIAMETER

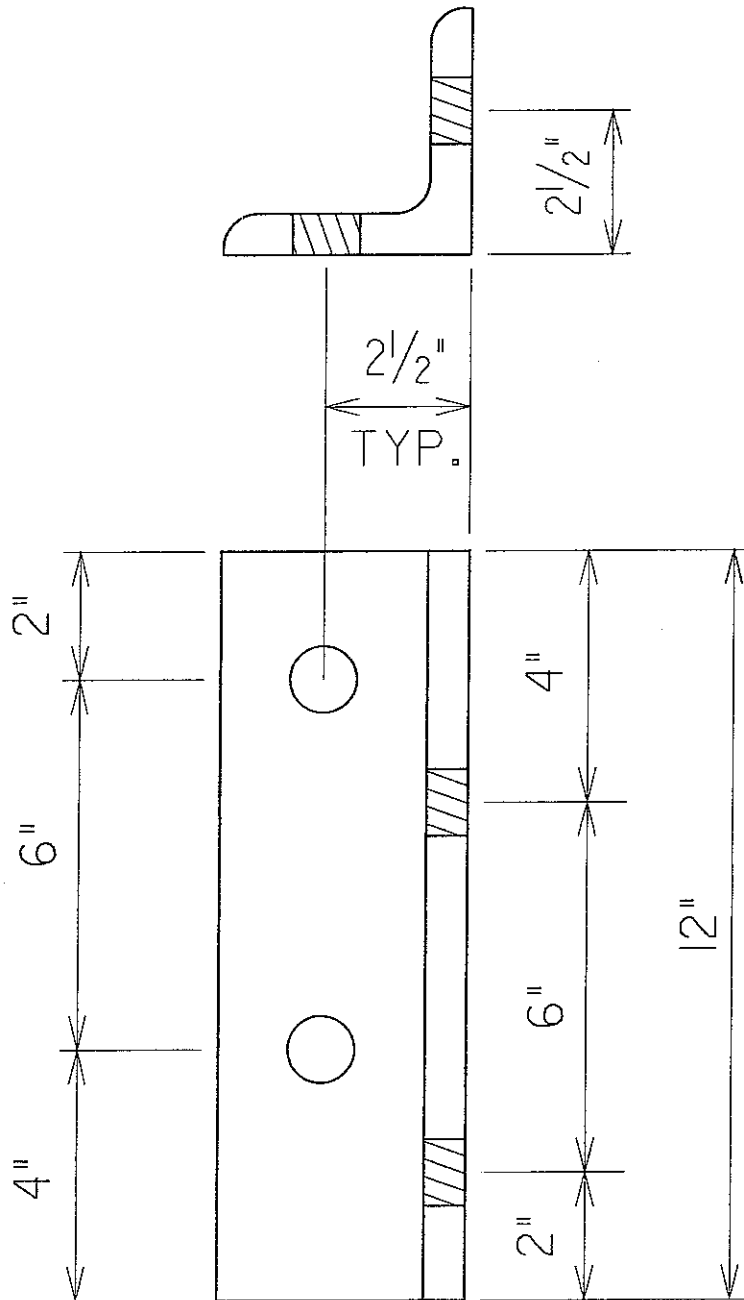

CLIP ANGLE

ANGLE 4" X 4" X 1/2" - 60 REQUIRED

A F F I D A V I T

West Virginia Code §5A-3-10a states:

No contract or renewal of any contract may be awarded by the state or any of its political subdivisions to any vendor or prospective vendor when the vendor or prospective vendor or a related party to the vendor or prospective vendor is a debtor and the debt owned is an amount greater than one thousand dollars in the aggregate

DEFINITIONS:

"Debt" means any assessment, premium, penalty, fine, tax or other amount of money owed to the state or any of its political subdivisions because of a judgment, fine, permit violation, license assessment, defaulted workers' compensation premium, penalty or other assessment presently delinquent or due and required to be paid to the state or any of its political subdivisions, including any interest or additional penalties accrued thereon.

"Debtor" means any individual, corporation, partnership, association, limited liability company or any other form or business association owing a debt to the state or any of its political subdivisions "Political subdivision" means any county commission; municipality; county board of education; any instrumentality established by a county or municipality; any separate corporation or instrumentality established by one or more counties or municipalities, as permitted by law; or any public body charged by law with the performance of a government function or whose jurisdiction is coextensive with one or more counties or municipalities "Related party" means a party, whether an individual, corporation, partnership, association, limited liability company or any other form or business association or other entity whatsoever, related to any vendor by blood, marriage, ownership or contract through which the party has a relationship of ownership or other interest with the vendor so that the party will actually or by effect receive or control a portion of the benefit, profit or other consideration from performance of a vendor contract with the party receiving an amount that meets or exceed five percent of the total contract amount

EXCEPTION:

The prohibition of this section does not apply where a vendor has contested any tax administered pursuant to chapter eleven of this code, workers' compensation premium, permit fee or environmental fee or assessment and the matter has not become final or where the vendor has entered into a payment plan or agreement and the vendor is not in default of any of the provisions of such plan or agreement.

LICENSING:

Vendors must be licensed and in good standing in accordance with any and all state and local laws and requirements by any state or local agency of West Virginia, including, but not limited to, the West Virginia Secretary of State's Office, the West Virginia Tax Department, West Virginia Insurance Commission, or any other state agencies or political subdivision. Furthermore, the vendor must provide all necessary releases to obtain information to enable the Director or spending unit to verify that the vendor is licensed and in good standing with the above entities.

CONFIDENTIALITY:

The vendor agrees that he or she will not disclose to anyone, directly or indirectly, any such personally identifiable information or other confidential information gained from the agency, unless the individual who is the subject of the information consents to the disclosure in writing or the disclosure is made pursuant to the agency's policies, procedures and rules Vendors should visit www.state.wv.us/admin/purchase/privacy for the Notice of Agency Confidentiality Policies.

Under penalty of law for false swearing (West Virginia Code, §61-5-3), it is hereby certified that the vendor acknowledges the information in this said affidavit and are in compliance with the requirements as stated

Vendor's Name: CHARLESTON STEEL Co

Authorized Signature: Dennis Nicholas

Date: 2/20/07