



The following documentation is an electronically-submitted vendor response to an advertised solicitation from the *West Virginia Purchasing Bulletin* within the Vendor Self-Service portal at wvOASIS.gov. As part of the State of West Virginia's procurement process, and to maintain the transparency of the bid-opening process, this documentation submitted online is publicly posted by the West Virginia Purchasing Division at WVPurchasing.gov with any other vendor responses to this solicitation submitted to the Purchasing Division in hard copy format.

Header 3

List View

- General Information**
- Contact
- Default Values
- Discount
- Document Information
- Clarification Request

Procurement Folder: 1919880

Procurement Type: Central Purchase Order

Vendor ID:

Legal Name: CENTRAL RESTAURANT PRODUCTS

Alias/DBA:

Total Bid: \$45,599.88

Response Date:

Response Time:

Responded By User ID:

First Name:

Last Name:

Email:

Phone:

SO Doc Code: CRFQ

SO Dept: 0603

SO Doc ID: ADJ2600000021

Published Date: 5/20/26

Close Date: 5/27/26

Close Time: 13:30

Status: Closed

Solicitation Description:

Total of Header Attachments: 3

Total of All Attachments: 3



Department of Administration
 Purchasing Division
 2019 Washington Street East
 Post Office Box 50130
 Charleston, WV 25305-0130

**State of West Virginia
 Solicitation Response**

Proc Folder: 1919880
Solicitation Description: Ovens for Mountaineer Challenge Academy Dining Facility
Proc Type: Central Purchase Order

Solicitation Closes	Solicitation Response	Version
2026-05-27 13:30	SR 0603 ESR05272600000008263	1

VENDOR
 000000100611
 CENTRAL RESTAURANT PRODUCTS

Solicitation Number: CRFQ 0603 ADJ2600000021
Total Bid: 45599.87999999999738065525889 **Response Date:** 2026-05-27 **Response Time:** 13:21:52
Comments:

FOR INFORMATION CONTACT THE BUYER
 David H Pauline
 304-558-0067
 david.h.pauline@wv.gov

Vendor Signature X **FEIN#** **DATE**

All offers subject to all terms and conditions contained in this solicitation

Line	Comm Ln Desc	Qty	Unit Issue	Unit Price	Ln Total Or Contract Amount
1	Gas Combi Ovens	2.00000	EA	22799.940000	45599.88

Comm Code	Manufacturer	Specification	Model #
48101507			

Commodity Line Comments: \$45599.87 is the price is for (2) Convotharm C4 ET 6.20GS-N Combi ovens (double stacked), pre-install site survey, installation of both units, installation of both water filtration systems, (2) installation kits, (2) water filtration systems, and (1) stacking kit

Extended Description:

Please refer to the Exhibit "A" Pricing Page to input unit pricing.

Project _____
 Item _____
 Quantity _____
 FCSI section _____
 Approval _____
 Date _____

Convotherm maxx pro easyTouch

- 6.20
- 7 slide rails
- Gas
- Injection/Spritzer
- Right-hinged door



Key Features

- Advanced Closed System+ (ACS+) cooking methods: Steam, combi-steam, hot air
- Advanced Closed System+ (ACS+) with extra functions:
 - Crisp&Tasty - 5 moisture-removal settings
 - BakePro - 5 levels of traditional baking
 - HumidityPro - 5 humidity settings
 - Controllable fan - 5 speed settings
- easyTouch 10" TFT high-resolution glass touch display (capacitive)
- ConvoClean+ fully automatic cleaning system with eco, regular and express modes - with optional single-dose dispensing
- HygieniCare
- WiFi and Ethernet port (LAN)
- TriColor indicator ring - indicates the current operating status
- Steam generated by injecting water into the cooking chamber
- LED illumination for cooking chamber
- Triple-glazed right-hinged unit door

Standard features

- Cooking methods:
 - Steam (86-266°F) with guaranteed steam saturation
 - Combi-steam (86-482°F) with automatic humidity adjustment
 - Hot air (86-482°F) with optimized heat transfer
- easyTouch user interface controls:
 - 10" TFT high-resolution glass touch display (capacitive)
 - Smooth-action, quick-reacting scrolling function
- Climate Management
 - Advanced Closed System+ (ACS+), HumidityPro, Crisp&Tasty
- Quality Management
 - Airflow Management, BakePro, multi-point core temperature probe, preheat and cool-down function
- Production Management
 - Automatic cooking with Press&Go with up to 399 profiles
 - Integrated cookbook with 7 different categories
 - TrayTimer - load management for different products simultaneously
 - TrayView - load management for automatic cooking of different products using Press&Go
 - Favorites management
 - HACCP data storage
 - USB port
 - ecoCooking - energy saving function
 - LT cooking (low-temperature cooking) / Delta-T cooking
 - Cook&Hold - cooking and keeping food warm in a single process
 - Auto Start
 - Rethermalization+: versatile multi-mode rethermalization function

Standard features

- Cleaning Management:
 - ConvoClean+: Fully automatic cleaning system
 - Quick access to individually created and stored cleaning profiles
 - Cleaning Scheduler
- HygieniCare:
 - Hygienic Steam Function
 - Hygienic handles
 - SteamDisinfect
- Design:
 - Triple-glazed right-hinged unit door with safety lock, sure-shut function, venting position, and LEDs for illuminating the cooking chamber
 - Steam generated by injecting water into the cooking chamber
 - Adjustable feet with adjustment range between 4 inches and 5 inches
 - Multi-point core temperature probe
 - Integrated recoil hand shower



Options

Accessories

Convotherm maxx pro easyTouch

- 6.20
- 7 slide rails
- Gas
- Injection/Spritzer
- Right-hinged door



Key Features

- Advanced Closed System+ (ACS+) cooking methods: Steam, combi-steam, hot air
- Advanced Closed System+ (ACS+) with extra functions:
 - Crisp&Tasty - 5 moisture-removal settings
 - BakePro - 5 levels of traditional baking
 - HumidityPro - 5 humidity settings
 - Controllable fan - 5 speed settings
- easyTouch 10" TFT high-resolution glass touch display (capacitive)
- ConvoClean+ fully automatic cleaning system with eco, regular and express modes - with optional single-dose dispensing
- HygieniCare
- WiFi and Ethernet port (LAN)
- TriColor indicator ring - indicates the current operating status
- Steam generated by injecting water into the cooking chamber
- LED illumination for cooking chamber
- Triple-glazed right-hinged unit door

Options

- Triple-glazed disappearing door - more space and added safety (see page 3)
- Quality Management:
 - ConvoSmoke - built in food-smoking (HotSmoke)
 - ConvoGrill with grease management function
- Steam and vapor removal - built-in condenser
- Corrections package
- Available in various voltages
- Sous-vide probe, external connection
- Core temperature probe, external connection (internal core probe standard)

Accessories

- KitchenConnect® (WiFi/LAN), network solution from Welbilt for updating and monitoring appliances from anywhere
- Signal Tower
- Racks
- Banquet system (optionally as a package or individually): Plate rack, mobile shelf rack, transport trolley, thermal cover
- Stacking stands
- Equipment stands in various sizes and designs

Accessories and services by partners

- Cleaning chemicals for the fully automatic ConvoClean+ cleaning system (multiple-dose and single-dose dispensing)
- Water filtration and reverse osmosis systems and replacement filters
- Installation services available - details in AutoQuotes - availability may vary by region
- Cooking, baking, and roasting cookware

Front view

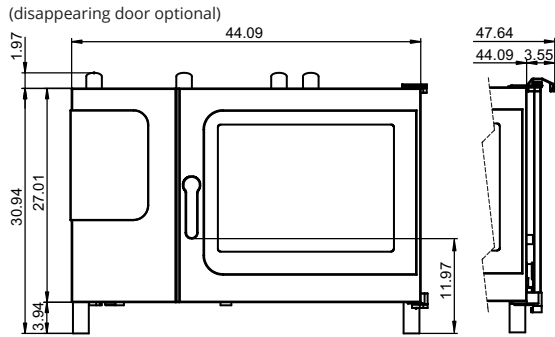

Connection points, bottom of unit

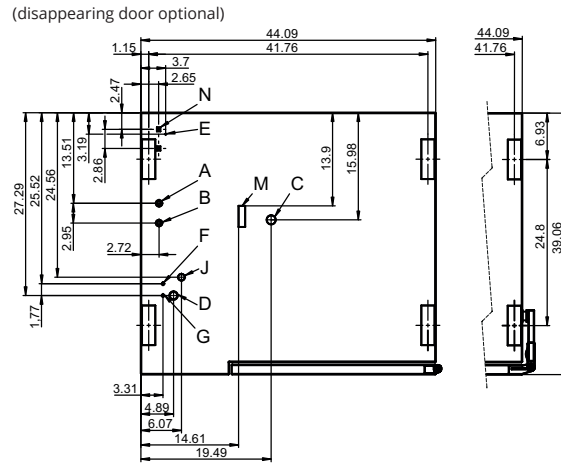

View from above with wall clearances

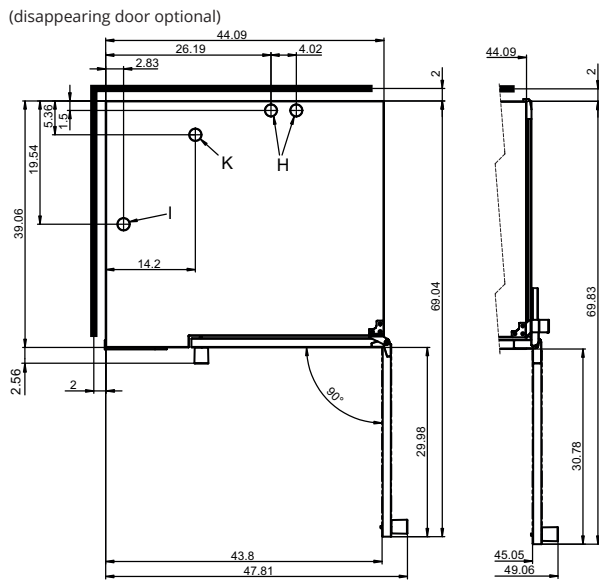

- A Water connection (for water injection)
- B Water connection (for cleaning, recoil hand shower)
- C Drain connection (2" I. D.)
- D Electrical connection
- E Equipotential bonding
- F Rinse-aid connection
- G Cleaning-agent connection
- H Air vent (2" I. D.)
- I Dry air intake (2" I. D.)
- J Gas connection
- K Exhaust outlet (2" I.D.)
- M Safety overflow 3.2" x 1"
- N Ethernet connection RJ45

Dimensions and weights

Dimensions including packaging
 Width x height x depth 53.7" x 41.3" x 45.7"

Weight
 Net weight without options* / accessories 326 lbs
 Packaging weight 77 lbs

Safety clearances**	
Rear	2"
Right (right-hinged door)	2"
Right (disappearing door pushed back)	5"
Left (see installation requirements)	2"
Top***	39"

* Max. weight of options: 33 lbs.
 ** Required for the unit to work properly.
 *** Depends on the type of exhaust system and the ceiling's characteristics.

Installation requirements

Clearance from heat sources	min. 20"
Recommended clearance for servicing on the left side of the unit	min. 20"

The combi oven must be easily accessible on three sides in order to ensure accessibility for cleaning. Alternatively, use a 6" foot, available upon request.

Loading capacity

Max. number of food containers [Unit has 7slide rails; rail spacing 2.68" max.]	
Steam table pans (12"x20"x1")	14
Steam table pans (12"x20"x2.5")	14
Wire shelves, full size (20"x26")	7
Sheet pans, full size (18"x26")*	6
Sheet pans, half size (13"x18")*	12
Frying baskets, half size (12"x20")	14
Plates (optional plate rack)	27
Max. loading weight	
Per combi oven	132 lbs
Per shelf level	33 lbs

* Wire shelves required.

Electrical supply

120V 1PH 60Hz *	
Rated power consumption	0.6 kW
Rated current	7.5 A
Power supply wire gauge	14 AWG
Conductor insulation rating	194 °F / 90 °C

* Prepared for connection to an energy optimizing system.

The electrical power supply must be connected to a dedicated permanent supply line. Any ground fault circuit interrupters or residual current devices used must be rated for at least 20mA. Do not connect to residential GFCI outlets, as they will cause nuisance tripping on the device.

Gas specifications

Type of gas	Natural gas, propane
Gas connection	1/2" NPT
Flow pressure	
Natural gas	7" WC
Propane	11" WC
Heat output	For Natural gas, propane
Convection burner	68200 BTU/h

Water connection

Water supply	
Water supply	2 x 3/4" GHT-M garden hose adapter; Alternative, 2 hoses 1/2" inner diameter with one side 3/4" GHT-F to 3/4" BST. The unit is designed for a fixed connection to the water supply using a connecting hose with a minimum inner diameter of 1/2"
Flow pressure	22 - 87 psi / 1.5 - 6 bar
Drain	
Drain version	Naturally ventilated pipe to open pan or drain/channel
Type	2" inner diameter
Slope for drainpipe	min. 3.5% (2°)

Water quality

Water connection A* for water injection	
General requirements	Drinking water, typically treated water (install a water treatment system if necessary)
TDS	70 - 125 ppm
Hardness	70 - 125 ppm (4 - 7 gpg)
Water connection B* for cleaning, recoil hand shower	
General requirements	Drinking water, typically untreated water
TDS	70 - 360 ppm
Hardness	70 - 360 ppm (4 - 21 gpg)
Water connections A, B*	
pH value	6.5 - 8.5
Cl ⁻ (chloride)	max. 60 ppm
Cl ₂ (free chlorine)	max. 0.2 ppm
SO ₄ ²⁻ (sulfate)	max. 150 ppm
Fe (iron)	max. 0.1 ppm
SiO ₂ (silica)	max. 13 ppm
NH ₂ Cl (monochloramine)	max. 0.2 ppm
Temperature	max. 104°F / max. 40°C

* Please refer to the connection points diagram, p. 2.

NOTICE: The owner/operator/purchaser must ensure that the water quality requirements are met. Otherwise the unit warranty is void.

Water consumption

Water connection A*	
Average consumption for cooking	1.4 gph
Max. water throughput	0.2 gpm
Water connections A, B	
Average consumption for cooking**	2.0 gph
Max. water throughput	4.0 gpm

* Values intended as guide for specifying the water treatment system.

** Incl. water required for cooling the wastewater.

NOTICE: See connection positions diagram, p. 2.

Emissions

Heat loss	
Latent	3100 BTU/h
Sensible	4800 BTU/h
Drain temperature	max. 140°F / 60°C
Decibel rating	max. 70 dBA

ACCESSORIES

(For more detailed information, please refer to the Accessories brochure.)

Stacking kit

Combinations allowed	6.20 on 6.20 6.20 on 10.20
----------------------	-------------------------------

If combining two gas units

Select the "stacking kit for Convotherm 4 gas units"

If combining one electrical unit and one gas unit in a stacking kit

Select the "stacking kit for Convotherm 4 electrical units" if:

Bottom combi oven	EB/ES
-------------------	-------

Top combi oven	GB/GS
----------------	-------

Select the "stacking kit for Convotherm 4 gas units" if:

Bottom combi oven	GB/GS
-------------------	-------

Top combi oven	EB/ES
----------------	-------

Equipment stand

Standard support surface height	26.38"
---------------------------------	--------



Department of Administration
 Purchasing Division
 2019 Washington Street East
 Post Office Box 50130
 Charleston, WV 25305-0130

**State of West Virginia
 Centralized Request for Quote
 Equipment**

Proc Folder: 1919880		Reason for Modification:	
Doc Description: Ovens for Mountaineer Challenge Academy Dining Facility		Addendum No. 1	
Proc Type: Central Purchase Order			
Date Issued	Solicitation Closes	Solicitation No	Version
2026-05-20	2026-05-27 13:30	CRFQ 0603 ADJ2600000021	2

BID RECEIVING LOCATION

BID CLERK
 DEPARTMENT OF ADMINISTRATION
 PURCHASING DIVISION
 2019 WASHINGTON ST E
 CHARLESTON WV 25305
 US

VENDOR

Vendor Customer Code: 479292
Vendor Name : CENTRAL RESTAURANT PRODUCTS
Address : 9555 Dry Fork Road
Street :
City : Harrison
State : OH **Country :** USA **Zip :** 45030
Principal Contact : Andrew Kemp
Vendor Contact Phone: 317-238-8374 **Extension:** DIRECT

FOR INFORMATION CONTACT THE BUYER

David H Pauline
 304-558-0067
 david.h.pauline@wv.gov

Vendor Signature X *Andrew Kemp* **FEIN#** 03-0605365 **DATE** 5/27/26

All offers subject to all terms and conditions contained in this solicitation

ADDITIONAL INFORMATION

Addendum No. 1

To provide responses to the vendor technical questions, see attached.

Bid opening date and time remains May 27, 2026, at 1:30 pm. EST.

No other changes.

INVOICE TO**SHIP TO**ADJUTANT GENERALS
OFFICE
1703 COONSKIN DRADJUTANT GENERALS
OFFICE
1001 ARMY RDCHARLESTON WV
USKINGWOOD WV
US

Line	Comm Ln Desc	Qty	Unit Issue	Unit Price	Total Price
1	Gas Combi Ovens	2.00000	EA		

Comm Code**Manufacturer****Specification****Model #**

48101507

Extended Description:

Please refer to the Exhibit "A" Pricing Page to input unit pricing.

SCHEDULE OF EVENTS

<u>Line</u>	<u>Event</u>	<u>Event Date</u>
1	Vendor Technical Questions Due By 11:00 am. EST.	2026-05-19

	Document Phase	Document Description	Page
ADJ2600000021	Final	Ovens for Mountaineer Challenge Academy Dining Facility	3

ADDITIONAL TERMS AND CONDITIONS

See attached document(s) for additional Terms and Conditions



Department of Administration
 Purchasing Division
 2019 Washington Street East
 Post Office Box 50130
 Charleston, WV 25305-0130

State of West Virginia
Centralized Request for Quote
Equipment

Proc Folder: 1919880		Reason for Modification:	
Doc Description: Ovens for Mountaineer Challenge Academy Dining Facility		Addendum No. 1	
Proc Type: Central Purchase Order			
Date Issued	Solicitation Closes	Solicitation No	Version
2026-05-20	2026-05-27 13:30	CRFQ 0603 ADJ2600000021	2

BID RECEIVING LOCATION

BID CLERK
 DEPARTMENT OF ADMINISTRATION
 PURCHASING DIVISION
 2019 WASHINGTON ST E
 CHARLESTON WV 25305
 US

VENDOR

Vendor Customer Code:
Vendor Name : CENTRAL RESTAURANT PRODUCTS
Address :
Street : 9555 Dry Fork Road
City : Harrison
State : OH **Country :** USA **Zip :** 45030
Principal Contact : Andrew Kemp
Vendor Contact Phone: 317.238.8374 **Extension:** DIRECT LINE

FOR INFORMATION CONTACT THE BUYER

David H Pauline
 304-558-0067
 david.h.pauline@wv.gov

Vendor Signature X

Andrew Kemp

FEIN# 03-0605365

DATE 5/27/26

All offers subject to all terms and conditions contained in this solicitation

ADDITIONAL INFORMATION

Addendum No. 1

To provide responses to the vendor technical questions, see attached.

Bid opening date and time remains May 27, 2026, at 1:30 pm. EST.

No other changes.

INVOICE TO**SHIP TO**ADJUTANT GENERALS
OFFICE
1703 COONSKIN DRADJUTANT GENERALS
OFFICE
1001 ARMY RDCHARLESTON WV
USKINGWOOD WV
US

Line	Comm Ln Desc	Qty	Unit Issue	Unit Price	Total Price
1	Gas Combi Ovens	2.00000	EA		

Comm Code**Manufacturer****Specification****Model #**

48101507

Extended Description:

Please refer to the Exhibit "A" Pricing Page to input unit pricing.

SCHEDULE OF EVENTS

<u>Line</u>	<u>Event</u>	<u>Event Date</u>
1	Vendor Technical Questions Due By 11:00 am. EST.	2026-05-19

SOLICITATION NUMBER: CRFQ ADJ2600000021
Addendum Number: 1

The purpose of this addendum is to modify the solicitation identified as (“ADJ2600000021”) to reflect the change(s) identified and described below.

Applicable Addendum Category:

- Modify bid opening date and time.
- Modify specifications of product or service being sought.
- Attachment of vendor questions and responses.
- Attachment of pre-bid sign-in sheet.
- Correction of error.
- Other.

Description of Modification to Solicitation:

- 1) To provide responses to the Vendor Technical Questions, see attached
- 2) The bid opening date and time remains May 27, 2026, at 1:30 pm. EST.

No other changes.

Additional Documentation: Documentation related to this Addendum (if any) has been included herewith as Attachment A and is specifically incorporated herein by reference.

Terms and Conditions:

1. All provisions of the Solicitation and other addenda not modified herein shall remain in full force and effect.
2. Vendor should acknowledge receipt of all addenda issued for this Solicitation by completing an Addendum Acknowledgment, a copy of which is included herewith. Failure to acknowledge addenda may result in bid disqualification. The addendum acknowledgement should be submitted with the bid to expedite document processing.



DEPARTMENT OF THE ARMY
JOINT FORCES HEADQUARTERS WEST VIRGINIA
1707 COONSKIN DRIVE
CHARLESTON, WEST VIRGINIA 25311-1026

May 19, 2026

ADDENDUM NO. 1- CRFQ-ADJ2600000021

RE: Ovens for the Mountaineer Challenge Academy

TO: Prospective Bidders

FROM: West Virginia Adjutant General's Office

PART 1 – TO ISSUE RESPONSES TO TECHNICAL QUESTIONS RECEIVED

Q1: What size combi ovens are you all wanting? “There are a few options ranging from 6, 10, 20 pan options. I have attached a brochure for example.”

A1: The two (2) combi oven sizes should accommodate a 6-pan option.

Q2: What voltage and gas type is needed for the ovens?

A2: 120v voltage and natural gas type.

Q3: Please confirm the delivery/install location address and if there is a loading dock at the location?

A3: There is a loading dock located at Camp Dawson - Mountaineer Challenge Academy – Dining Facility Building # 443 - 1001 Army Road, Kingwood, WV 26537. Once the shipment arrives, the security at the front gate will call the facility and the driver will be escorted inside the complex to the building.

Q4: Will the installers need to remove any existing equipment? If so please provide make and model of items being removed from location?

A4: No, installers will not need to remove any existing equipment. The Vendor must deliver the combi ovens inside the building, uncrate the units in place within three (3) feet of existing equipment and utilities, provide all hoses and connectors to make all electrical and plumbing connections, and ensure the units are working correctly and are ready for immediate operation. Vendor is to demonstrate programming options to MCA Staff and provide minimal preventative maintenance, troubleshooting, repair, and diagnostic instructions.

Q5: There is not a specific manufacture or model number for this request. Are there specifications available for the unit to be purchased?

A5: Convotherm Maxx Pro Model No. C4 ET 6.20GS-N, or equal, and per the solicitation specifications in the General Requirements section listed under 3.1.1.

ADDENDUM ACKNOWLEDGEMENT FORM
SOLICITATION NO.: CRFQ ADJ260000021

Instructions: Please acknowledge receipt of all addenda issued with this solicitation by completing this addendum acknowledgment form. Check the box next to each addendum received and sign below. Failure to acknowledge addenda may result in bid disqualification.

Acknowledgment: I hereby acknowledge receipt of the following addenda and have made the necessary revisions to my proposal, plans and/or specification, etc.

Addendum Numbers Received:

(Check the box next to each addendum received)

- | | | | |
|-------------------------------------|----------------|--------------------------|-----------------|
| <input checked="" type="checkbox"/> | Addendum No. 1 | <input type="checkbox"/> | Addendum No. 6 |
| <input type="checkbox"/> | Addendum No. 2 | <input type="checkbox"/> | Addendum No. 7 |
| <input type="checkbox"/> | Addendum No. 3 | <input type="checkbox"/> | Addendum No. 8 |
| <input type="checkbox"/> | Addendum No. 4 | <input type="checkbox"/> | Addendum No. 9 |
| <input type="checkbox"/> | Addendum No. 5 | <input type="checkbox"/> | Addendum No. 10 |

I understand that failure to confirm the receipt of addenda may be cause for rejection of this bid. I further understand that that any verbal representation made or assumed to be made during any oral discussion held between Vendor's representatives and any state personnel is not binding. Only the information issued in writing and added to the specifications by an official addendum is binding.

CENTRAL RESTAURANT PRODUCTS

Company

Andrew Kemp

Authorized Signature

5/27/26

Date

NOTE: This addendum acknowledgment should be submitted with the bid to expedite document processing.