



Department of Administration  
 Purchasing Division  
 2019 Washington Street East  
 Post Office Box 50130  
 Charleston, WV 25305-0130

State of West Virginia  
 Centralized Request for Quote  
 Miscellaneous

Proc Folder: 1382717		Reason for Modification:	
Doc Description: 0524C0202 - INSULATED CONCRETE FORMS & ACCESSORIES			
Proc Type: Central Master Agreement			
Date Issued	Solicitation Closes	Solicitation No	Version
2024-02-27	2024-03-13 13:30	CRFQ 0803 DOT2400000071	1

**BID RECEIVING LOCATION**

BID CLERK  
 DEPARTMENT OF ADMINISTRATION  
 PURCHASING DIVISION  
 2019 WASHINGTON ST E  
 CHARLESTON WV 25305  
 US

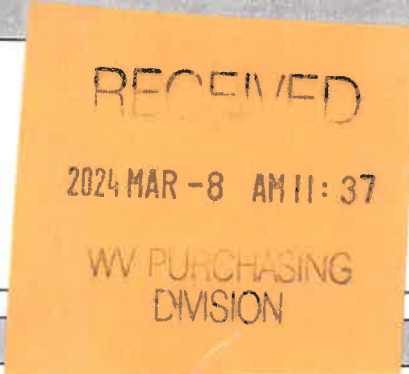

**VENDOR**

Vendor Customer Code: 090000160527  
 Vendor Name: Stone & Company  
 Address: 606 McCormick Ave  
 Street:  
 City: Connellsville  
 State: PA Country: Fayette Zip: 15425  
 Principal Contact: Neil Mason or Charlie Hixon 724-836-1400  
 Vendor Contact Phone: 724-889-7409 Extension: 136

**FOR INFORMATION CONTACT THE BUYER**  
 John W Estep  
 304-558-2566  
 john.w.estep@wv.gov

Vendor Signature X  FEIN# [REDACTED] DATE 3-5-24

All offers subject to all terms and conditions contained in this solicitation

**ADDITIONAL INFORMATION****REQUEST FOR QUOTATION:**

The West Virginia Purchasing Division is soliciting bids on behalf of West Virginia Division of Highways, District Five to establish an open-end contract for the purchase of Insulated Concrete Forms (ICFs) and accessories, as needed throughout District Five. Per the Bid Requirements, Specifications, Terms and Conditions attached to this solicitation.

INVOICE TO		SHIP TO	
DIVISION OF HIGHWAYS DISTRICT FIVE		STATE OF WEST VIRGINIA VARIOUS LOCATIONS AS INDICATED BY ORDER	
PO BOX 99 BURLINGTON US	WV	No City US	WV

Line	Comm Ln Desc	Qty	Unit Issue	Unit Price	Total Price
1	NUDURA 6" STANDARD FORM UNIT OR EQUAL	550.00000	EA	\$ 73.55	\$ 40,452.50

Comm Code	Manufacturer	Specification	Model #
30191801	Nudura	3.1.1	NUD6ST

**Extended Description:**

NUDURA 6" STANDARD FORM UNIT OR EQUAL

INVOICE TO		SHIP TO	
DIVISION OF HIGHWAYS DISTRICT FIVE		STATE OF WEST VIRGINIA VARIOUS LOCATIONS AS INDICATED BY ORDER	
PO BOX 99 BURLINGTON US	WV	No City US	WV

Line	Comm Ln Desc	Qty	Unit Issue	Unit Price	Total Price
2	NUDURA 6" 90 DEGREE CORNER FORM OR EQUAL	100.00000	EA	\$ 36.80	\$ 3,680.00

Comm Code	Manufacturer	Specification	Model #
30191801	Nudura	3.1.1	NUD690

**Extended Description:**

NUDURA 6" 90 DEGREE CORNER FORM OR EQUAL

INVOICE TO		SHIP TO	
DIVISION OF HIGHWAYS DISTRICT FIVE  PO BOX 99 BURLINGTON WV US		STATE OF WEST VIRGINIA VARIOUS LOCATIONS AS INDICATED BY ORDER  No City WV US	

Line	Comm Ln Desc	Qty	Unit Issue	Unit Price	Total Price
3	6" FORM LOCK	150.00000	EA	# 9.95	# 1492.50

Comm Code	Manufacturer	Specification	Model #
30191801	Nudura	3.1.4.1	NUD6FL

Extended Description:  
6" FORM LOCK

INVOICE TO		SHIP TO	
DIVISION OF HIGHWAYS DISTRICT FIVE  PO BOX 99 BURLINGTON WV US		STATE OF WEST VIRGINIA VARIOUS LOCATIONS AS INDICATED BY ORDER  No City WV US	

Line	Comm Ln Desc	Qty	Unit Issue	Unit Price	Total Price
4	4" PROTECTIVE TAPE	40.00000	EA	# 5.20	# 208.00

Comm Code	Manufacturer	Specification	Model #
30191801	Nudura	3.1.4.2	NUDTAPE

Extended Description:  
4" PROTECTIVE TAPE

INVOICE TO		SHIP TO	
DIVISION OF HIGHWAYS DISTRICT FIVE  PO BOX 99 BURLINGTON WV US		STATE OF WEST VIRGINIA VARIOUS LOCATIONS AS INDICATED BY ORDER  No City WV US	

Line	Comm Ln Desc	Qty	Unit Issue	Unit Price	Total Price
5	1" FIBRE TAPE	2.00000	EA	# 5.35	# 10.70

Comm Code	Manufacturer	Specification	Model #
30191801	Nudura	3.1.4.3	NUDF TAPE

Extended Description:  
1" FIBRE TAPE

INVOICE TO		SHIP TO	
DIVISION OF HIGHWAYS DISTRICT FIVE  PO BOX 99 BURLINGTON WV US		STATE OF WEST VIRGINIA VARIOUS LOCATIONS AS INDICATED BY ORDER  No City WV US	

Line	Comm Ln Desc	Qty	Unit Issue	Unit Price	Total Price
6	LOW EXPANSION SPRAY FOAM	50.00000	EA	# 17.10	# 855.00

Comm Code	Manufacturer	Specification	Model #
30191801	Nudura	3.1.4.4	NUD FOAM

Extended Description:  
LOW EXPANSION SPRAY FOAM

INVOICE TO			SHIP TO		
DIVISION OF HIGHWAYS DISTRICT FIVE			STATE OF WEST VIRGINIA VARIOUS LOCATIONS AS INDICATED BY ORDER		
PO BOX 99					
BURLINGTON	WV		No City		WV
US			US		

Line	Comm Ln Desc	Qty	Unit Issue	Unit Price	Total Price
7	FOAM GUN CLEANER	25.00000	EA	\$ 14.40	\$ 360.00

Comm Code	Manufacturer	Specification	Model #
30191801	Nudura	3.1.4.5	NUDFGC

Extended Description:  
FOAM GUN CLEANER

INVOICE TO			SHIP TO		
DIVISION OF HIGHWAYS DISTRICT FIVE			STATE OF WEST VIRGINIA VARIOUS LOCATIONS AS INDICATED BY ORDER		
PO BOX 99					
BURLINGTON	WV		No City		WV
US			US		

Line	Comm Ln Desc	Qty	Unit Issue	Unit Price	Total Price
8	FOAM GUN	25.00000	EA	60.30	\$ 1,507.50

Comm Code	Manufacturer	Specification	Model #
30191801	Nudura	3.1.4.6	NUDFGM

Extended Description:  
FOAM GUN

INVOICE TO			SHIP TO		
DIVISION OF HIGHWAYS DISTRICT FIVE			STATE OF WEST VIRGINIA VARIOUS LOCATIONS AS INDICATED BY ORDER		
PO BOX 99 BURLINGTON US	WV		No City US	WV	

Line	Comm Ln Desc	Qty	Unit Issue	Unit Price	Total Price
9	NUDURAL VERTICAL JOINT CLIP OR EQUAL	1000.00000	EA	.90	\$ 900.00

Comm Code	Manufacturer	Specification	Model #
30191801	Nudura	3.1.4.7	NUDVJC

**Extended Description:**  
NUDURAL VERTICAL JOINT CLIP OR EQUAL

INVOICE TO			SHIP TO		
DIVISION OF HIGHWAYS DISTRICT FIVE			STATE OF WEST VIRGINIA VARIOUS LOCATIONS AS INDICATED BY ORDER		
PO BOX 99 BURLINGTON US	WV		No City US	WV	

Line	Comm Ln Desc	Qty	Unit Issue	Unit Price	Total Price
10	NUDURA 11.25" X 16' PREBUCK OR EQUAL	200.00000	EA	\$ 154.35	\$ 30,870.00

Comm Code	Manufacturer	Specification	Model #
30191801	Nudura	3.1.3	NUDPB616 NMF

**Extended Description:**  
NUDURA 11.25" X 16' PREBUCK OR EQUAL

INVOICE TO		SHIP TO	
DIVISION OF HIGHWAYS DISTRICT FIVE  PO BOX 99 BURLINGTON WV US		STATE OF WEST VIRGINIA VARIOUS LOCATIONS AS INDICATED BY ORDER  No City WV US	

Line	Comm Ln Desc	Qty	Unit Issue	Unit Price	Total Price
11	NUDURA 1.5" L-ANGLE FOR PREBUCK OR EQUAL	200.00000	EA	# 13.00	# 2600.00

Comm Code	Manufacturer	Specification	Model #
30191801	Nudura	3.1.3	NUD PBMLA

**Extended Description:**  
NUDURA 1.5" L-ANGLE FOR PREBUCK OR EQUAL

INVOICE TO		SHIP TO	
DIVISION OF HIGHWAYS DISTRICT FIVE  PO BOX 99 BURLINGTON WV US		STATE OF WEST VIRGINIA VARIOUS LOCATIONS AS INDICATED BY ORDER  No City WV US	

Line	Comm Ln Desc	Qty	Unit Issue	Unit Price	Total Price
12	2" SCREWS W/ WASHER (AT LEAST 1,000 PER UNIT)	2.00000	EA	# 139.60	# 279.20

Comm Code	Manufacturer	Specification	Model #
30191801	NUDURA	3.1.4.8	NUD25

**Extended Description:**  
2" SCREWS W/ WASHER (AT LEAST 1,000 PER UNIT)

INVOICE TO		SHIP TO	
DIVISION OF HIGHWAYS DISTRICT FIVE  PO BOX 99 BURLINGTON WV US		STATE OF WEST VIRGINIA VARIOUS LOCATIONS AS INDICATED BY ORDER  No City WV US	

Line	Comm Ln Desc	Qty	Unit Issue	Unit Price	Total Price
13	NUDURA SQ. TUBE BRACING 10' - 20 SETS OR EQUAL	5.00000	EA	\$ 6,531.00	\$ 32,655.00

Comm Code	Manufacturer	Specification	Model #
30191801	Nudura	3.1.5	NUD BST10R

**Extended Description:**  
NUDURA SQ. TUBE BRACING 10' - 20 SETS OR EQUAL

INVOICE TO		SHIP TO	
DIVISION OF HIGHWAYS DISTRICT FIVE  PO BOX 99 BURLINGTON WV US		STATE OF WEST VIRGINIA VARIOUS LOCATIONS AS INDICATED BY ORDER  No City WV US	

Line	Comm Ln Desc	Qty	Unit Issue	Unit Price	Total Price
14	NUDURA ONE SERIES OUTSIDE 90 DEGREE CORNER OR EQUAL	60.00000	EA	\$ 27.70	\$ 1,662.00

Comm Code	Manufacturer	Specification	Model #
30191801		3.1.2	NUD15OUT 90

**Extended Description:**  
NUDURA ONE SERIES OUTSIDE 90 DEGREE CORNER OR EQUAL



INVOICE TO		SHIP TO	
DIVISION OF HIGHWAYS DISTRICT FIVE  PO BOX 99 BURLINGTON WV US		STATE OF WEST VIRGINIA VARIOUS LOCATIONS AS INDICATED BY ORDER  No City WV US	

Line	Comm Ln Desc	Qty	Unit Issue	Unit Price	Total Price
15	NUDURA ONE SERIES MULTI FORM TIE OR EQUAL - at least 95 pcs/	50.00000	EA	\$ 144.90	\$ 7,245.00

Comm Code	Manufacturer	Specification	Model #
30191801	Nudura	3.1.2	NUDISMFT

**Extended Description:**  
NUDURA ONE SERIES MULTI FORM TIE OR EQUAL - at least 95 pcs/

INVOICE TO		SHIP TO	
DIVISION OF HIGHWAYS DISTRICT FIVE  PO BOX 99 BURLINGTON WV US		STATE OF WEST VIRGINIA VARIOUS LOCATIONS AS INDICATED BY ORDER  No City WV US	

Line	Comm Ln Desc	Qty	Unit Issue	Unit Price	Total Price
16	NUDURA ONE SERIES CORNER BRACKET 10' OR EQUAL	10.00000	EA	\$ 91.95	\$ 919.50

Comm Code	Manufacturer	Specification	Model #
30191801	Nudura	3.1.4.12	NUDISCB

**Extended Description:**  
NUDURA ONE SERIES CORNER BRACKET 10' OR EQUAL

INVOICE TO		SHIP TO	
DIVISION OF HIGHWAYS DISTRICT FIVE  PO BOX 99 BURLINGTON WV US		STATE OF WEST VIRGINIA VARIOUS LOCATIONS AS INDICATED BY ORDER  No City WV US	

Line	Comm Ln Desc	Qty	Unit Issue	Unit Price	Total Price
17	NUDURA ONE SERIES METAL JIG OR EQUAL	5.00000	EA	\$ 273.70	\$ 1,368.50

Comm Code	Manufacturer	Specification	Model #
30191801	Nudura	3.1.4.13	NUD15 ONE JIG

**Extended Description:**  
NUDURA ONE SERIES METAL JIG OR EQUAL

INVOICE TO		SHIP TO	
DIVISION OF HIGHWAYS DISTRICT FIVE  PO BOX 99 BURLINGTON WV US		STATE OF WEST VIRGINIA VARIOUS LOCATIONS AS INDICATED BY ORDER  No City WV US	

Line	Comm Ln Desc	Qty	Unit Issue	Unit Price	Total Price
18	NUDURA UNASSEMBLED STANDARD FORM OR EQUAL	200.00000	EA	\$ 65.45	\$ 13,090.00

Comm Code	Manufacturer	Specification	Model #
30191801	Nudura	3.1.1	NUDUA ST

**Extended Description:**  
NUDURA UNASSEMBLED STANDARD FORM OR EQUAL

INVOICE TO		SHIP TO	
DIVISION OF HIGHWAYS DISTRICT FIVE		STATE OF WEST VIRGINIA VARIOUS LOCATIONS AS INDICATED BY ORDER	
PO BOX 99 BURLINGTON US	WV	No City US	WV

Line	Comm Ln Desc	Qty	Unit Issue	Unit Price	Total Price
19	NUDURA ONE SERIES PLYPAN 18" X 8' OR EQUAL	400.00000	EA	\$ 100.30	\$ 40,120.00

Comm Code	Manufacturer	Specification	Model #
30191801	Nudura	3.1.2	NUDISPP

**Extended Description:**  
NUDURA ONE SERIES PLYPAN 18" X 8' OR EQUAL

INVOICE TO		SHIP TO	
DIVISION OF HIGHWAYS DISTRICT FIVE		STATE OF WEST VIRGINIA VARIOUS LOCATIONS AS INDICATED BY ORDER	
PO BOX 99 BURLINGTON US	WV	No City US	WV

Line	Comm Ln Desc	Qty	Unit Issue	Unit Price	Total Price
20	NUDURA PLYPAN REPL. INSERTS - AT LEAST 2400 PCS/UNIT OR EQUA	5.00000	EA	\$ 800.85	\$ 4,004.25

Comm Code	Manufacturer	Specification	Model #
30191801	Nudura	3.1.4.9	NUDISPPI

**Extended Description:**  
NUDURA PLYPAN REPL. INSERTS - AT LEAST 2400 PCS/UNIT OR EQUA

INVOICE TO	SHIP TO
------------	---------

DIVISION OF HIGHWAYS DISTRICT FIVE  PO BOX 99 BURLINGTON WV US	STATE OF WEST VIRGINIA VARIOUS LOCATIONS AS INDICATED BY ORDER  No City WV US
---	--

Line	Comm Ln Desc	Qty	Unit Issue	Unit Price	Total Price
21	10" SLIDE IN WEB - 100 PCS/BOX	50.00000	EA	\$ 110.00	\$ 5,500.00

Comm Code	Manufacturer	Specification	Model #
30191801		3.1.4.10	NUB10SW

**Extended Description:**  
 10" SLIDE IN WEB - 100 PCS/BOX

SCHEDULE OF EVENTS
--------------------

<u>Line</u>	<u>Event</u>	<u>Event Date</u>
1	Tech Questions due by 10:00am	2024-03-05

	Document Phase	Document Description	Page
DOT2400000071	Final	0524C0202 - INSULATED CONCRETE FORMS & ACCESSORIES	13

**ADDITIONAL TERMS AND CONDITIONS**

See attached document(s) for additional Terms and Conditions

## **GENERAL TERMS AND CONDITIONS:**

**1. CONTRACTUAL AGREEMENT:** Issuance of an Award Document signed by the Purchasing Division Director, or his designee, and approved as to form by the Attorney General's office constitutes acceptance by the State of this Contract made by and between the State of West Virginia and the Vendor. Vendor's signature on its bid, or on the Contract if the Contract is not the result of a bid solicitation, signifies Vendor's agreement to be bound by and accept the terms and conditions contained in this Contract.

**2. DEFINITIONS:** As used in this Solicitation/Contract, the following terms shall have the meanings attributed to them below. Additional definitions may be found in the specifications included with this Solicitation/Contract.

**2.1. "Agency" or "Agencies"** means the agency, board, commission, or other entity of the State of West Virginia that is identified on the first page of the Solicitation or any other public entity seeking to procure goods or services under this Contract.

**2.2. "Bid" or "Proposal"** means the vendors submitted response to this solicitation.

**2.3. "Contract"** means the binding agreement that is entered into between the State and the Vendor to provide the goods or services requested in the Solicitation.

**2.4. "Director"** means the Director of the West Virginia Department of Administration, Purchasing Division.

**2.5. "Purchasing Division"** means the West Virginia Department of Administration, Purchasing Division.

**2.6. "Award Document"** means the document signed by the Agency and the Purchasing Division, and approved as to form by the Attorney General, that identifies the Vendor as the contract holder.

**2.7. "Solicitation"** means the official notice of an opportunity to supply the State with goods or services that is published by the Purchasing Division.

**2.8. "State"** means the State of West Virginia and/or any of its agencies, commissions, boards, etc. as context requires.

**2.9. "Vendor" or "Vendors"** means any entity submitting a bid in response to the Solicitation, the entity that has been selected as the lowest responsible bidder, or the entity that has been awarded the Contract as context requires.

**3. CONTRACT TERM; RENEWAL; EXTENSION:** The term of this Contract shall be determined in accordance with the category that has been identified as applicable to this Contract below:

**Term Contract**

**Initial Contract Term:** The Initial Contract Term will be for a period of one (1) year. The Initial Contract Term becomes effective on the effective start date listed on the first page of this Contract, identified as the State of West Virginia contract cover page containing the signatures of the Purchasing Division, Attorney General, and Encumbrance clerk (or another page identified as \_\_\_\_\_), and the Initial Contract Term ends on the effective end date also shown on the first page of this Contract.

**Renewal Term:** This Contract may be renewed upon the mutual written consent of the Agency, and the Vendor, with approval of the Purchasing Division and the Attorney General's office (Attorney General approval is as to form only). Any request for renewal should be delivered to the Agency and then submitted to the Purchasing Division thirty (30) days prior to the expiration date of the initial contract term or appropriate renewal term. A Contract renewal shall be in accordance with the terms and conditions of the original contract. Unless otherwise specified below, renewal of this Contract is limited to three (3) successive one (1) year periods or multiple renewal periods of less than one year, provided that the multiple renewal periods do not exceed the total number of months available in all renewal years combined. Automatic renewal of this Contract is prohibited. Renewals must be approved by the Vendor, Agency, Purchasing Division and Attorney General's office (Attorney General approval is as to form only)

**Alternate Renewal Term** – This contract may be renewed for \_\_\_\_\_ successive \_\_\_\_\_ year periods or shorter periods provided that they do not exceed the total number of months contained in all available renewals. Automatic renewal of this Contract is prohibited. Renewals must be approved by the Vendor, Agency, Purchasing Division and Attorney General's office (Attorney General approval is as to form only)

**Delivery Order Limitations:** In the event that this contract permits delivery orders, a delivery order may only be issued during the time this Contract is in effect. Any delivery order issued within one year of the expiration of this Contract shall be effective for one year from the date the delivery order is issued. No delivery order may be extended beyond one year after this Contract has expired.

**Fixed Period Contract:** This Contract becomes effective upon Vendor's receipt of the notice to proceed and must be completed within \_\_\_\_\_ days.

**Fixed Period Contract with Renewals:** This Contract becomes effective upon Vendor's receipt of the notice to proceed and part of the Contract more fully described in the attached specifications must be completed within \_\_\_\_\_ days. Upon completion of the work covered by the preceding sentence, the vendor agrees that:

the contract will continue for \_\_\_\_\_ years;

the contract may be renewed for \_\_\_\_\_ successive \_\_\_\_\_ year periods or shorter periods provided that they do not exceed the total number of months contained in all available renewals. Automatic renewal of this Contract is prohibited. Renewals must be approved by the Vendor, Agency, Purchasing Division and Attorney General's Office (Attorney General approval is as to form only).

**One-Time Purchase:** The term of this Contract shall run from the issuance of the Award Document until all of the goods contracted for have been delivered, but in no event will this Contract extend for more than one fiscal year.

**Construction/Project Oversight:** This Contract becomes effective on the effective start date listed on the first page of this Contract, identified as the State of West Virginia contract cover page containing the signatures of the Purchasing Division, Attorney General, and Encumbrance clerk (or another page identified as \_\_\_\_\_), and continues until the project for which the vendor is providing oversight is complete.

**Other:** Contract Term specified in \_\_\_\_\_

**4. AUTHORITY TO PROCEED:** Vendor is authorized to begin performance of this contract on the date of encumbrance listed on the front page of the Award Document unless either the box for "Fixed Period Contract" or "Fixed Period Contract with Renewals" has been checked in Section 3 above. If either "Fixed Period Contract" or "Fixed Period Contract with Renewals" has been checked, Vendor must not begin work until it receives a separate notice to proceed from the State. The notice to proceed will then be incorporated into the Contract via change order to memorialize the official date that work commenced.

**5. QUANTITIES:** The quantities required under this Contract shall be determined in accordance with the category that has been identified as applicable to this Contract below.

**Open End Contract:** Quantities listed in this Solicitation/Award Document are approximations only, based on estimates supplied by the Agency. It is understood and agreed that the Contract shall cover the quantities actually ordered for delivery during the term of the Contract, whether more or less than the quantities shown.

**Service:** The scope of the service to be provided will be more clearly defined in the specifications included herewith.

**Combined Service and Goods:** The scope of the service and deliverable goods to be provided will be more clearly defined in the specifications included herewith.



**One-Time Purchase:** This Contract is for the purchase of a set quantity of goods that are identified in the specifications included herewith. Once those items have been delivered, no additional goods may be procured under this Contract without an appropriate change order approved by the Vendor, Agency, Purchasing Division, and Attorney General's office.

**Construction:** This Contract is for construction activity more fully defined in the specifications.

**6. EMERGENCY PURCHASES:** The Purchasing Division Director may authorize the Agency to purchase goods or services in the open market that Vendor would otherwise provide under this Contract if those goods or services are for immediate or expedited delivery in an emergency. Emergencies shall include, but are not limited to, delays in transportation or an unanticipated increase in the volume of work. An emergency purchase in the open market, approved by the Purchasing Division Director, shall not constitute a breach of this Contract and shall not entitle the Vendor to any form of compensation or damages. This provision does not excuse the State from fulfilling its obligations under a One-Time Purchase contract.

**7. REQUIRED DOCUMENTS:** All of the items checked in this section must be provided to the Purchasing Division by the Vendor as specified:

**LICENSE(S) / CERTIFICATIONS / PERMITS:** In addition to anything required under the Section of the General Terms and Conditions entitled Licensing, the apparent successful Vendor shall furnish proof of the following licenses, certifications, and/or permits upon request and in a form acceptable to the State. The request may be prior to or after contract award at the State's sole discretion.

The apparent successful Vendor shall also furnish proof of any additional licenses or certifications contained in the specifications regardless of whether or not that requirement is listed above.

**8. INSURANCE:** The apparent successful Vendor shall furnish proof of the insurance identified by a checkmark below prior to Contract award. The insurance coverages identified below must be maintained throughout the life of this contract. Thirty (30) days prior to the expiration of the insurance policies, Vendor shall provide the Agency with proof that the insurance mandated herein has been continued. Vendor must also provide Agency with immediate notice of any changes in its insurance policies, including but not limited to, policy cancelation, policy reduction, or change in insurers. The apparent successful Vendor shall also furnish proof of any additional insurance requirements contained in the specifications prior to Contract award regardless of whether that insurance requirement is listed in this section.

Vendor must maintain:

**Commercial General Liability Insurance** in at least an amount of: \$1,000,000 per occurrence.

**Automobile Liability Insurance** in at least an amount of: \$1,000,000 per occurrence.

**Professional/Malpractice/Errors and Omission Insurance** in at least an amount of: \_\_\_\_\_ per occurrence. Notwithstanding the forgoing, Vendor's are not required to list the State as an additional insured for this type of policy.

**Commercial Crime and Third Party Fidelity Insurance** in an amount of: \_\_\_\_\_ per occurrence.

**Cyber Liability Insurance** in an amount of: \_\_\_\_\_ per occurrence.

**Builders Risk Insurance** in an amount equal to 100% of the amount of the Contract.

**Pollution Insurance** in an amount of: \_\_\_\_\_ per occurrence.

**Aircraft Liability** in an amount of: \_\_\_\_\_ per occurrence.

**9. WORKERS' COMPENSATION INSURANCE:** Vendor shall comply with laws relating to workers compensation, shall maintain workers' compensation insurance when required, and shall furnish proof of workers' compensation insurance upon request.

**10. VENUE:** All legal actions for damages brought by Vendor against the State shall be brought in the West Virginia Claims Commission. Other causes of action must be brought in the West Virginia court authorized by statute to exercise jurisdiction over it.

**11. LIQUIDATED DAMAGES:** This clause shall in no way be considered exclusive and shall not limit the State or Agency's right to pursue any other available remedy. Vendor shall pay liquidated damages in the amount specified below or as described in the specifications:

\_\_\_\_\_ for \_\_\_\_\_.

Liquidated Damages Contained in the Specifications.

Liquidated Damages Are Not Included in this Contract.

**12. ACCEPTANCE:** Vendor's signature on its bid, or on the certification and signature page, constitutes an offer to the State that cannot be unilaterally withdrawn, signifies that the product or service proposed by vendor meets the mandatory requirements contained in the Solicitation for that product or service, unless otherwise indicated, and signifies acceptance of the terms and conditions contained in the Solicitation unless otherwise indicated.

**13. PRICING:** The pricing set forth herein is firm for the life of the Contract, unless specified elsewhere within this Solicitation/Contract by the State. A Vendor's inclusion of price adjustment provisions in its bid, without an express authorization from the State in the Solicitation to do so, may result in bid disqualification. Notwithstanding the foregoing, Vendor must extend any publicly advertised sale price to the State and invoice at the lower of the contract price or the publicly advertised sale price.

**14. PAYMENT IN ARREARS:** Payments for goods/services will be made in arrears only upon receipt of a proper invoice, detailing the goods/services provided or receipt of the goods/services, whichever is later. Notwithstanding the foregoing, payments for software maintenance, licenses, or subscriptions may be paid annually in advance.

**15. PAYMENT METHODS:** Vendor must accept payment by electronic funds transfer and P-Card. (The State of West Virginia's Purchasing Card program, administered under contract by a banking institution, processes payment for goods and services through state designated credit cards.)

**16. TAXES:** The Vendor shall pay any applicable sales, use, personal property or any other taxes arising out of this Contract and the transactions contemplated thereby. The State of West Virginia is exempt from federal and state taxes and will not pay or reimburse such taxes.

**17. ADDITIONAL FEES:** Vendor is not permitted to charge additional fees or assess additional charges that were not either expressly provided for in the solicitation published by the State of West Virginia, included in the Contract, or included in the unit price or lump sum bid amount that Vendor is required by the solicitation to provide. Including such fees or charges as notes to the solicitation may result in rejection of vendor's bid. Requesting such fees or charges be paid after the contract has been awarded may result in cancellation of the contract.

**18. FUNDING:** This Contract shall continue for the term stated herein, contingent upon funds being appropriated by the Legislature or otherwise being made available. In the event funds are not appropriated or otherwise made available, this Contract becomes void and of no effect beginning on July 1 of the fiscal year for which funding has not been appropriated or otherwise made available. If that occurs, the State may notify the Vendor that an alternative source of funding has been obtained and thereby avoid the automatic termination. Non-appropriation or non-funding shall not be considered an event of default.

**19. CANCELLATION:** The Purchasing Division Director reserves the right to cancel this Contract immediately upon written notice to the vendor if the materials or workmanship supplied do not conform to the specifications contained in the Contract. The Purchasing Division Director may also cancel any purchase or Contract upon 30 days written notice to the Vendor in accordance with West Virginia Code of State Rules § 148-1-5.2.b.

**20. TIME:** Time is of the essence regarding all matters of time and performance in this Contract.

**21. APPLICABLE LAW:** This Contract is governed by and interpreted under West Virginia law without giving effect to its choice of law principles. Any information provided in specification manuals, or any other source, verbal or written, which contradicts or violates the West Virginia Constitution, West Virginia Code, or West Virginia Code of State Rules is void and of no effect.

**22. COMPLIANCE WITH LAWS:** Vendor shall comply with all applicable federal, state, and local laws, regulations and ordinances. By submitting a bid, Vendor acknowledges that it has reviewed, understands, and will comply with all applicable laws, regulations, and ordinances.

**SUBCONTRACTOR COMPLIANCE:** Vendor shall notify all subcontractors providing commodities or services related to this Contract that as subcontractors, they too are required to comply with all applicable laws, regulations, and ordinances. Notification under this provision must occur prior to the performance of any work under the contract by the subcontractor.

**23. ARBITRATION:** Any references made to arbitration contained in this Contract, Vendor's bid, or in any American Institute of Architects documents pertaining to this Contract are hereby deleted, void, and of no effect.

**24. MODIFICATIONS:** This writing is the parties' final expression of intent. Notwithstanding anything contained in this Contract to the contrary no modification of this Contract shall be binding without mutual written consent of the Agency, and the Vendor, with approval of the Purchasing Division and the Attorney General's office (Attorney General approval is as to form only). Any change to existing contracts that adds work or changes contract cost, and were not included in the original contract, must be approved by the Purchasing Division and the Attorney General's Office (as to form) prior to the implementation of the change or commencement of work affected by the change.

**25. WAIVER:** The failure of either party to insist upon a strict performance of any of the terms or provision of this Contract, or to exercise any option, right, or remedy herein contained, shall not be construed as a waiver or a relinquishment for the future of such term, provision, option, right, or remedy, but the same shall continue in full force and effect. Any waiver must be expressly stated in writing and signed by the waiving party.

**26. SUBSEQUENT FORMS:** The terms and conditions contained in this Contract shall supersede any and all subsequent terms and conditions which may appear on any form documents submitted by Vendor to the Agency or Purchasing Division such as price lists, order forms, invoices, sales agreements, or maintenance agreements, and includes internet websites or other electronic documents. Acceptance or use of Vendor's forms does not constitute acceptance of the terms and conditions contained thereon.

**27. ASSIGNMENT:** Neither this Contract nor any monies due, or to become due hereunder, may be assigned by the Vendor without the express written consent of the Agency, the Purchasing Division, the Attorney General's office (as to form only), and any other government agency or office that may be required to approve such assignments.

**28. WARRANTY:** The Vendor expressly warrants that the goods and/or services covered by this Contract will: (a) conform to the specifications, drawings, samples, or other description furnished or specified by the Agency; (b) be merchantable and fit for the purpose intended; and (c) be free from defect in material and workmanship.

**29. STATE EMPLOYEES:** State employees are not permitted to utilize this Contract for personal use and the Vendor is prohibited from permitting or facilitating the same.

**30. PRIVACY, SECURITY, AND CONFIDENTIALITY:** The Vendor agrees that it will not disclose to anyone, directly or indirectly, any such personally identifiable information or other confidential information gained from the Agency, unless the individual who is the subject of the information consents to the disclosure in writing or the disclosure is made pursuant to the Agency's policies, procedures, and rules. Vendor further agrees to comply with the Confidentiality Policies and Information Security Accountability Requirements, set forth in [www.state.wv.us/admin/purchase/privacy](http://www.state.wv.us/admin/purchase/privacy).

**31. YOUR SUBMISSION IS A PUBLIC DOCUMENT:** Vendor's entire response to the Solicitation and the resulting Contract are public documents. As public documents, they will be disclosed to the public following the bid/proposal opening or award of the contract, as required by the competitive bidding laws of West Virginia Code §§ 5A-3-1 et seq., 5-22-1 et seq., and 5G-1-1 et seq. and the Freedom of Information Act West Virginia Code §§ 29B-1-1 et seq.

**DO NOT SUBMIT MATERIAL YOU CONSIDER TO BE CONFIDENTIAL, A TRADE SECRET, OR OTHERWISE NOT SUBJECT TO PUBLIC DISCLOSURE.**

Submission of any bid, proposal, or other document to the Purchasing Division constitutes your explicit consent to the subsequent public disclosure of the bid, proposal, or document. The Purchasing Division will disclose any document labeled "confidential," "proprietary," "trade secret," "private," or labeled with any other claim against public disclosure of the documents, to include any "trade secrets" as defined by West Virginia Code § 47-22-1 et seq. All submissions are subject to public disclosure without notice.

**32. LICENSING:** In accordance with West Virginia Code of State Rules § 148-1-6.1.e, Vendor must be licensed and in good standing in accordance with any and all state and local laws and requirements by any state or local agency of West Virginia, including, but not limited to, the West Virginia Secretary of State's Office, the West Virginia Tax Department, West Virginia Insurance Commission, or any other state agency or political subdivision. Obligations related to political subdivisions may include, but are not limited to, business licensing, business and occupation taxes, inspection compliance, permitting, etc. Upon request, the Vendor must provide all necessary releases to obtain information to enable the Purchasing Division Director or the Agency to verify that the Vendor is licensed and in good standing with the above entities.

**SUBCONTRACTOR COMPLIANCE:** Vendor shall notify all subcontractors providing commodities or services related to this Contract that as subcontractors, they too are required to be licensed, in good standing, and up-to-date on all state and local obligations as described in this section. Obligations related to political subdivisions may include, but are not limited to, business licensing, business and occupation taxes, inspection compliance, permitting, etc. Notification under this provision must occur prior to the performance of any work under the contract by the subcontractor.

**33. ANTITRUST:** In submitting a bid to, signing a contract with, or accepting a Award Document from any agency of the State of West Virginia, the Vendor agrees to convey, sell, assign, or transfer to the State of West Virginia all rights, title, and interest in and to all causes of action it may now or hereafter acquire under the antitrust laws of the United States and the State of West Virginia for price fixing and/or unreasonable restraints of trade relating to the particular commodities or services purchased or acquired by the State of West Virginia. Such assignment shall be made and become effective at the time the purchasing agency tenders the initial payment to Vendor.

**34. VENDOR NON-CONFLICT:** Neither Vendor nor its representatives are permitted to have any interest, nor shall they acquire any interest, direct or indirect, which would compromise the performance of its services hereunder. Any such interests shall be promptly presented in detail to the Agency.

**35. VENDOR RELATIONSHIP:** The relationship of the Vendor to the State shall be that of an independent contractor and no principal-agent relationship or employer-employee relationship is contemplated or created by this Contract. The Vendor as an independent contractor is solely liable for the acts and omissions of its employees and agents. Vendor shall be responsible for selecting, supervising, and compensating any and all individuals employed pursuant to the terms of this Solicitation and resulting contract. Neither the Vendor, nor any employees or subcontractors of the Vendor, shall be deemed to be employees of the State for any purpose whatsoever. Vendor shall be exclusively responsible for payment of employees and contractors for all wages and salaries, taxes, withholding payments, penalties, fees, fringe benefits, professional liability insurance premiums, contributions to insurance and pension, or other deferred compensation plans, including but not limited to, Workers' Compensation and Social Security obligations, licensing fees, etc. and the filing of all necessary documents, forms, and returns pertinent to all of the foregoing.

Vendor shall hold harmless the State, and shall provide the State and Agency with a defense against any and all claims including, but not limited to, the foregoing payments, withholdings, contributions, taxes, Social Security taxes, and employer income tax returns.

**36. INDEMNIFICATION:** The Vendor agrees to indemnify, defend, and hold harmless the State and the Agency, their officers, and employees from and against: (1) Any claims or losses for services rendered by any subcontractor, person, or firm performing or supplying services, materials, or supplies in connection with the performance of the Contract; (2) Any claims or losses resulting to any person or entity injured or damaged by the Vendor, its officers, employees, or subcontractors by the publication, translation, reproduction, delivery, performance, use, or disposition of any data used under the Contract in a manner not authorized by the Contract, or by Federal or State statutes or regulations; and (3) Any failure of the Vendor, its officers, employees, or subcontractors to observe State and Federal laws including, but not limited to, labor and wage and hour laws.

**37. NO DEBT CERTIFICATION:** In accordance with West Virginia Code §§ 5A-3-10a and 5-22-1(i), the State is prohibited from awarding a contract to any bidder that owes a debt to the State or a political subdivision of the State. By submitting a bid, or entering into a contract with the State, Vendor is affirming that (1) for construction contracts, the Vendor is not in default on any monetary obligation owed to the state or a political subdivision of the state, and (2) for all other contracts, neither the Vendor nor any related party owe a debt as defined above, and neither the Vendor nor any related party are in employer default as defined in the statute cited above unless the debt or employer default is permitted under the statute.

**38. CONFLICT OF INTEREST:** Vendor, its officers or members or employees, shall not presently have or acquire an interest, direct or indirect, which would conflict with or compromise the performance of its obligations hereunder. Vendor shall periodically inquire of its officers, members and employees to ensure that a conflict of interest does not arise. Any conflict of interest discovered shall be promptly presented in detail to the Agency.

**39. REPORTS:** Vendor shall provide the Agency and/or the Purchasing Division with the following reports identified by a checked box below:

Such reports as the Agency and/or the Purchasing Division may request. Requested reports may include, but are not limited to, quantities purchased, agencies utilizing the contract, total contract expenditures by agency, etc.

Quarterly reports detailing the total quantity of purchases in units and dollars, along with a listing of purchases by agency. Quarterly reports should be delivered to the Purchasing Division via email at [purchasing.division@wv.gov](mailto:purchasing.division@wv.gov).

**40. BACKGROUND CHECK:** In accordance with W. Va. Code § 15-2D-3, the State reserves the right to prohibit a service provider's employees from accessing sensitive or critical information or to be present at the Capitol complex based upon results addressed from a criminal background check. Service providers should contact the West Virginia Division of Protective Services by phone at (304) 558-9911 for more information.

**41. PREFERENCE FOR USE OF DOMESTIC STEEL PRODUCTS:** Except when authorized by the Director of the Purchasing Division pursuant to W. Va. Code § 5A-3-56, no contractor may use or supply steel products for a State Contract Project other than those steel products made in the United States. A contractor who uses steel products in violation of this section may be subject to civil penalties pursuant to W. Va. Code § 5A-3-56. As used in this section:

- a. "State Contract Project" means any erection or construction of, or any addition to, alteration of or other improvement to any building or structure, including, but not limited to, roads or highways, or the installation of any heating or cooling or ventilating plants or other equipment, or the supply of and materials for such projects, pursuant to a contract with the State of West Virginia for which bids were solicited on or after June 6, 2001.
- b. "Steel Products" means products rolled, formed, shaped, drawn, extruded, forged, cast, fabricated or otherwise similarly processed, or processed by a combination of two or more or such operations, from steel made by the open heath, basic oxygen, electric furnace, Bessemer or other steel making process.
- c. The Purchasing Division Director may, in writing, authorize the use of foreign steel products if:
  1. The cost for each contract item used does not exceed one tenth of one percent (.1%) of the total contract cost or two thousand five hundred dollars (\$2,500.00), whichever is greater. For the purposes of this section, the cost is the value of the steel product as delivered to the project; or
  2. The Director of the Purchasing Division determines that specified steel materials are not produced in the United States in sufficient quantity or otherwise are not reasonably available to meet contract requirements.



**42. PREFERENCE FOR USE OF DOMESTIC ALUMINUM, GLASS, AND STEEL:** In Accordance with W. Va. Code § 5-19-1 et seq., and W. Va. CSR § 148-10-1 et seq., for every contract or subcontract, subject to the limitations contained herein, for the construction, reconstruction, alteration, repair, improvement or maintenance of public works or for the purchase of any item of machinery or equipment to be used at sites of public works, only domestic aluminum, glass or steel products shall be supplied unless the spending officer determines, in writing, after the receipt of offers or bids, (1) that the cost of domestic aluminum, glass or steel products is unreasonable or inconsistent with the public interest of the State of West Virginia, (2) that domestic aluminum, glass or steel products are not produced in sufficient quantities to meet the contract requirements, or (3) the available domestic aluminum, glass, or steel do not meet the contract specifications. This provision only applies to public works contracts awarded in an amount more than fifty thousand dollars (\$50,000) or public works contracts that require more than ten thousand pounds of steel products.

The cost of domestic aluminum, glass, or steel products may be unreasonable if the cost is more than twenty percent (20%) of the bid or offered price for foreign made aluminum, glass, or steel products. If the domestic aluminum, glass or steel products to be supplied or produced in a "substantial labor surplus area", as defined by the United States Department of Labor, the cost of domestic aluminum, glass, or steel products may be unreasonable if the cost is more than thirty percent (30%) of the bid or offered price for foreign made aluminum, glass, or steel products. This preference shall be applied to an item of machinery or equipment, as indicated above, when the item is a single unit of equipment or machinery manufactured primarily of aluminum, glass or steel, is part of a public works contract and has the sole purpose or of being a permanent part of a single public works project. This provision does not apply to equipment or machinery purchased by a spending unit for use by that spending unit and not as part of a single public works project.

All bids and offers including domestic aluminum, glass or steel products that exceed bid or offer prices including foreign aluminum, glass or steel products after application of the preferences provided in this provision may be reduced to a price equal to or lower than the lowest bid or offer price for foreign aluminum, glass or steel products plus the applicable preference. If the reduced bid or offer prices are made in writing and supersede the prior bid or offer prices, all bids or offers, including the reduced bid or offer prices, will be reevaluated in accordance with this rule.

**43. INTERESTED PARTY SUPPLEMENTAL DISCLOSURE:** W. Va. Code § 6D-1-2 requires that for contracts with an actual or estimated value of at least \$1 million, the Vendor must submit to the Agency a disclosure of interested parties prior to beginning work under this Contract. Additionally, the Vendor must submit a supplemental disclosure of interested parties reflecting any new or differing interested parties to the contract, which were not included in the original pre-work interested party disclosure, within 30 days following the completion or termination of the contract. A copy of that form is included with this solicitation or can be obtained from the WV Ethics Commission. This requirement does not apply to publicly traded companies listed on a national or international stock exchange. A more detailed definition of interested parties can be obtained from the form referenced above.

**44. PROHIBITION AGAINST USED OR REFURBISHED:** Unless expressly permitted in the solicitation published by the State, Vendor must provide new, unused commodities, and is prohibited from supplying used or refurbished commodities, in fulfilling its responsibilities under this Contract.

**45. VOID CONTRACT CLAUSES:** This Contract is subject to the provisions of West Virginia Code § 5A-3-62, which automatically voids certain contract clauses that violate State law.

**46. ISRAEL BOYCOTT:** Bidder understands and agrees that, pursuant to W. Va. Code § 5A-3-63, it is prohibited from engaging in a boycott of Israel during the term of this contract.

**DESIGNATED CONTACT:** Vendor appoints the individual identified in this Section as the Contract Administrator and the initial point of contact for matters relating to this Contract.

(Printed Name and Title) Charles Hixson - Builders Supply Manager  
(Address) 1718 Rosetown Rd Greensburg, PA 15601  
(Phone Number) / (Fax Number) 724-836-1400 ext 136 Fax 724-838-9455  
(email address) chixson@stoneconcrete.com

**CERTIFICATION AND SIGNATURE:** By signing below, or submitting documentation through wvOASIS, I certify that: I have reviewed this Solicitation/Contract in its entirety; that I understand the requirements, terms and conditions, and other information contained herein; that this bid, offer or proposal constitutes an offer to the State that cannot be unilaterally withdrawn; that the product or service proposed meets the mandatory requirements contained in the Solicitation/Contract for that product or service, unless otherwise stated herein; that the Vendor accepts the terms and conditions contained in the Solicitation, unless otherwise stated herein; that I am submitting this bid, offer or proposal for review and consideration; that this bid or offer was made without prior understanding, agreement, or connection with any entity submitting a bid or offer for the same material, supplies, equipment or services; that this bid or offer is in all respects fair and without collusion or fraud; that this Contract is accepted or entered into without any prior understanding, agreement, or connection to any other entity that could be considered a violation of law; that I am authorized by the Vendor to execute and submit this bid, offer, or proposal, or any documents related thereto on Vendor's behalf; that I am authorized to bind the vendor in a contractual relationship; and that to the best of my knowledge, the vendor has properly registered with any State agency that may require registration.

By signing below, I further certify that I understand this Contract is subject to the provisions of West Virginia Code § 5A-3-62, which automatically voids certain contract clauses that violate State law; and that pursuant to W. Va. Code 5A-3-63, the entity entering into this contract is prohibited from engaging in a boycott against Israel.

Wendell H. Stone & Company Inc.  
(Company)

(Signature of Authorized Representative)

Charles M. Hixson - Builders Supply Manager  
(Printed Name and Title of Authorized Representative) (Date)

724-836-1400 ext 136 Fax 724-838-9455  
(Phone Number) (Fax Number)

chixson@stoneconcrete.com  
(Email Address)

REQUEST FOR QUOTATION  
0524C0202 - Insulated Concrete Forms and Accessories

---

**SPECIFICATIONS**

1. **PURPOSE AND SCOPE:** The West Virginia Purchasing Division is soliciting bids on behalf of West Virginia Division of Highways, District Five to establish an open-end contract for the purchase of Insulated Concrete Forms (ICFs) and accessories, as needed throughout District Five.
  
2. **DEFINITIONS:** The terms listed below shall have the meanings assigned to them below. Additional definitions can be found in section 2 of the General Terms and Conditions.
  - 2.1 **“Contract Item” or “Contract Items”** means the list of items identified in Section 3.1 below and on the Pricing Pages.
  
  - 2.2 **“Pricing Pages”** means the schedule of prices, estimated order quantity, and totals contained in wvOASIS or attached hereto as Exhibit A, and used to evaluate the Solicitation responses.
  
  - 2.3 **“Solicitation”** means the official notice of an opportunity to supply the State with goods or services that is published by the Purchasing Division.
  
3. **GENERAL REQUIREMENTS:**
  - 3.1 **Contract Items and Mandatory Requirements:** Vendor shall provide Agency with the Contract Items listed below on an open-end and continuing basis. Contract Items must meet or exceed the mandatory requirements as shown below.
    - 3.1.1 **NUDURA ICF Series Insulated Concrete Forms or Equal**
      - 3.1.1.1 Insulated Concrete Form must have standard size of at least 96” x 18” to allow 12 square feet of wall to be placed in one step.
  
      - 3.1.1.2 Insulated Concrete Form must include feature that securely locks forms into place eliminating the need to wire forms.
  
      - 3.1.1.3 Insulated Concrete Form must include a continuous full height-fastening strip to help ensure wall heights are accurate and eliminates wall height shrinkage.

**REQUEST FOR QUOTATION**  
**0524C0202 - Insulated Concrete Forms and Accessories**

---

- 3.1.1.4** Insulated Concrete Form must include a hinge system that is be able to be shipped flat. Once delivered, ICF must be able to be easily unfolded and arrive ready for use.
- 3.1.1.5** Insulated Concrete Form must be 4 ways reversible so that no left and right corners are needed.
- 3.1.1.6** Specific types and sizes required listed on Exhibit A, Pricing Page.
- 3.1.1.7** If bidding an or equal product, Vendor must submit brand information and proof that specifications in this section are met by product bid.

**3.1.2 NUDURA ONE Series Insulated Concrete Forms or Equal**

- 3.1.2.1** Insulated Concrete Form must have standard size of at least 96" x 18" to allow 12 square feet of wall to be placed in one step.
- 3.1.2.2** Insulated Concrete Form must include feature that securely locks forms into place eliminating the need to wire forms.
- 3.1.2.3** Insulated Concrete Form must include a continuous full height-fastening strip to help ensure wall heights are accurate and eliminates wall height shrinkage.
- 3.1.2.4** Insulated Concrete Form must include a hinge system that is be able to be shipped flat. Once delivered, ICF must be able to be easily unfolded and arrive ready for use.
- 3.1.2.5** Insulated Concrete Form must include a standard ICF panel and a plywood panel. The plywood panel is only on one side to allow concrete to meet with the outside edge of an ICF. This eliminates the need to remove the foam.
- 3.1.2.6** Specific types and sizes required listed on Exhibit A, Pricing Page.

**REQUEST FOR QUOTATION**  
**0524C0202 - Insulated Concrete Forms and Accessories**

---

3.1.2.7 If bidding an or equal product, Vendor must submit brand information and proof that specifications in this section are met by product bid.

**3.1.3 Prebuck or Equal for Punched Openings (Windows/Doors)**

3.1.3.1 Must be made with treated Laminated Strand Lumber (LSL) that is at least 1 ½" thick. LSL must be guaranteed to not warp or lose strength over time.

3.1.3.2 Must be able to have direct contact with concrete.

3.1.3.3 Must meet AWWA standards for use category 2.

3.1.3.4 If bidding an or equal product, Vendor must submit brand information and proof that specifications in this section are met by product bid.

**3.1.4 Insulated Concrete Form Accessories**

3.1.4.1 6" Form Lock – Maintains wall straightness

3.1.4.2 4" Protective Tape – Must be 4" and able to stop concrete from flowing through.

3.1.4.3 1" Fibre Tape - Must be 1" and able to provide additional support for on-site cut forms.

3.1.4.4 Low Expansion Spray Foam – Must be compatible for use with Insulated Concrete Forms

3.1.4.5 Foam Gun Cleaner - Must be able to clean the Foam Gun bid on Pricing Page.

3.1.4.6 Foam Gun - Must have metal handle and be compatible with the Expansion Spray Foam bid on Pricing Page, as well as working with Insulated Concrete Forms.

3.1.4.7 Nudura Vertical Joint Clip or Equal – To bid or equal, Vertical Joint Clip must be sturdy and able to connect

REQUEST FOR QUOTATION  
0524C0202 - Insulated Concrete Forms and Accessories

---

forms together, replacing having to use wire or tape at vertical joints.

- 3.1.4.8 2" Screws w/Washer - Must be 2" and include an attached washer. Each unit should include at least 1,000 count.
- 3.1.4.9 Nudura Plypan Repl. Inserts Or Equal – To Bid or Equal, Inserts must be compatible with Nudura One Series Insulated Concrete Forms Or Equal bid on pricing page and have at least 2,400 pieces per unit.
- 3.1.4.10 10" slide in web inserts – Must be compatible with Nudura One Series Insulated Concrete Forms Or Equal bid on Pricing Page and must have at least 100 pcs. Per unit.
- 3.1.4.11 Nudura One Series Multi Form Tie Or Equal – To Bid or Equal, Multi Form Tie must be compatible with Nudura One Series Insulated Concrete Forms and must have at least 95 pcs. Per unit.
- 3.1.4.12 Nudura One Series Corner Bracket 10' Or Equal – To Bid or Equal, Corner Bracket must securely connect two panels together at corner and be compatible with Nudura One Series Insulated Concrete Form bid on Pricing Page.
- 3.1.4.13 Nudura One Series Metal Jig Or Equal – To bid Or Equal, Metal Jig must be compatible with Nudura One Series Insulated Concrete Form bid on Pricing Page.

**3.1.5 NUDURA Alignment System or Equal (SQ. Tube Bracing)**

- 3.1.5.1 Alignment System must include a Guardrail Post, Catwalk Bracket, Channel, Turnbuckle, and Foot Pad.
- 3.1.5.2 Alignment System must be able to support the weight of workers, wind loads, and Insulated Concrete Forms.
- 3.1.5.3 Alignment system must be strong enough to support concrete during the insulated concrete form construction process.

**REQUEST FOR QUOTATION**  
**0524C0202 - Insulated Concrete Forms and Accessories**

---

**3.1.5.4** Alignment System must be tested to meet all applicable North American Safety Standards.

**3.1.5.5** Bracing must be minimum of 10' long and include at least 20 sets.

**3.1.5.6** If bidding an or equal product, Vendor must submit brand information and proof that specifications in this section are met by product bid.

**3.1.6 Warranty**

**3.1.6.1** Items received from Vendor must be covered by a warranty. Vendor must include warranty details with bid submission.

**3.1.7 Other Vendor Responsibilities**

**3.1.7.1** Vendor must be willing to spend minimum of 16 hours with agency for On-The-Job training.

**3.1.7.2** On-The-Job Training must include the following at no additional cost:

**3.1.7.2.1** Installation and Concrete pour of first job

**3.1.7.2.2** Pre-Pour inspection of first job

**4. CONTRACT AWARD:**

**4.1 Contract Award:** The Contract is intended to provide Agencies with a purchase price on all Contract Items. The Contract shall be awarded to the Vendor that provides the Contract Items meeting the required specifications for the lowest overall total cost as shown on the Pricing Pages. If during the life of the contract another related Insulated Concrete Form or Accessory is deemed necessary to complete a project, the item(s) will be covered by this agreement. The Pricing Page lists all anticipated needed items.

**4.2 Pricing Pages:** Vendor should complete the Pricing Pages by multiplying the quantity estimated by the unit cost and placing the total in the Total Column. Vendor must also list the brand being bid for all applicable items.



REQUEST FOR QUOTATION  
0524C0202 - Insulated Concrete Forms and Accessories

---

Vendor should complete the Pricing Pages in their entirety as failure to do so may result in Vendor's bids being disqualified.

The Pricing Pages contain a list of the Contract Items and estimated purchase volume. The estimated purchase volume for each item represents the approximate volume of anticipated purchases only. No future use of the Contract or any individual item is guaranteed or implied.

Vendor should electronically enter the information into the Pricing Pages through wvOASIS, if available, or as an electronic document. In most cases, the Vendor can request an electronic copy of the Pricing Pages for bid purposes by sending an email request to the following address: [john.w.estep@wv.gov](mailto:john.w.estep@wv.gov).

**5. ORDERING AND PAYMENT:**

- 5.1 Ordering:** Vendor shall accept orders through wvOASIS, regular mail, facsimile, e-mail, or any other written form of communication. Vendor may, but is not required to, accept on-line orders through a secure internet ordering portal/website. If Vendor has the ability to accept on-line orders, it should include in its response a brief description of how Agencies may utilize the on-line ordering system. Vendor shall ensure that its on-line ordering system is properly secured prior to processing Agency orders on-line.

**Vendor must be able to accept orders from WVDOH based solely on project plans and/or drawings. Once WV DOH sends vendor plans/drawings, Vendor should be able to calculate all necessary products and accessories needed. Vendor should then be able to deliver all needed materials at one time to the job site specified by the WVDOH. Vendor must be able to deliver to any location within Berkeley, Grant, Hardy, Hampshire, Jefferson, Mineral, and Morgan counties.**

- 5.2 Payment:** Vendor shall accept payment in accordance with the payment procedures of the State of West Virginia.

**6. DELIVERY AND RETURN:**

- 6.1 Delivery Time:** Vendor shall deliver standard and Emergency orders within the timeframe agreed upon between Vendor and WVDOH at the start of each job. Vendor shall deliver emergency orders within Vendor shall ship all orders in accordance with the above schedule and shall not hold orders until a minimum delivery quantity is met.

REQUEST FOR QUOTATION  
0524C0202 - Insulated Concrete Forms and Accessories

---

**Freight should not be charged for Truckload orders. Truckload orders must be delivered with no freight charged to WV DOH. WV DOH also reserves the right to pick-up orders from vendor locations.**

- 6.2 Late Delivery:** The Agency placing the order under this Contract must be notified in writing if orders will be delayed for any reason. Any delay in delivery that could cause harm to an Agency will be grounds for cancellation of the delayed order, and/or obtaining the items ordered from a third party.

Any Agency seeking to obtain items from a third party under this provision must first obtain approval of the Purchasing Division.

- 6.3 Delivery Payment/Risk of Loss:** Standard order delivery shall be F.O.B. destination to the Agency's location. Vendor shall include the cost of standard order delivery charges in its bid pricing/discount and is not permitted to charge the Agency separately for such delivery. The Agency will pay delivery charges on all emergency orders provided that Vendor invoices those delivery costs as a separate charge with the original freight bill attached to the invoice.
- 6.4 Return of Unacceptable Items:** If the Agency deems the Contract Items to be unacceptable, the Contract Items shall be returned to Vendor at Vendor's expense and with no restocking charge. Vendor shall either make arrangements for the return within five (5) days of being notified that items are unacceptable, or permit the Agency to arrange for the return and reimburse Agency for delivery expenses. If the original packaging cannot be utilized for the return, Vendor will supply the Agency with appropriate return packaging upon request. All returns of unacceptable items shall be F.O.B. the Agency's location. The returned product shall either be replaced, or the Agency shall receive a full credit or refund for the purchase price, at the Agency's discretion.
- 6.5 Return Due to Agency Error:** Items ordered in error by the Agency will be returned for credit within 30 days of receipt, F.O.B. Vendor's location. Vendor shall not charge a restocking fee if returned products are in a resalable condition. Items shall be deemed to be in a resalable condition if they are unused and in the original packaging. Any restocking fee for items not in a resalable condition shall be the lower of the Vendor's customary restocking fee or 5% of the total invoiced value of the returned items.

**REQUEST FOR QUOTATION**  
**0524C0202 - Insulated Concrete Forms and Accessories**

---

**7. VENDOR DEFAULT:**

7.1 The following shall be considered a vendor default under this Contract.

- 7.1.1 Failure to provide Contract Items in accordance with the requirements contained herein.
- 7.1.2 Failure to comply with other specifications and requirements contained herein.
- 7.1.3 Failure to comply with any laws, rules, and ordinances applicable to the Contract Services provided under this Contract.
- 7.1.4 Failure to remedy deficient performance upon request.

7.2 The following remedies shall be available to Agency upon default.

- 7.2.1 Immediate cancellation of the Contract.
- 7.2.2 Immediate cancellation of one or more release orders issued under this Contract.
- 7.2.3 Any other remedies available in law or equity.

**8. MISCELLANEOUS:**

- 8.1 No Substitutions:** Vendor shall supply only Contract Items submitted in response to the Solicitation unless a contract modification is approved in accordance with the provisions contained in this Contract.
- 8.2 Vendor Supply:** Vendor must carry sufficient inventory of the Contract Items being offered to fulfill its obligations under this Contract. By signing its bid, Vendor certifies that it can supply the Contract Items contained in its bid response.

**REQUEST FOR QUOTATION**  
**0524C0202 - Insulated Concrete Forms and Accessories**

---

- 8.3 Reports:** Vendor shall provide quarterly reports and annual summaries to the Agency showing the Agency's items purchased, quantities of items purchased, and total dollar value of the items purchased. Vendor shall also provide reports, upon request, showing the items purchased during the term of this Contract, the quantity purchased for each of those items, and the total value of purchases for each of those items. Failure to supply such reports may be grounds for cancellation of this Contract.
- 8.4 Contract Manager:** During its performance of this Contract, Vendor must designate and maintain a primary contract manager responsible for overseeing Vendor's responsibilities under this Contract. The Contract manager must be available during normal business hours to address any customer service or other issues related to this Contract. Vendor should list its Contract manager and his or her contact information below.

**Contract Manager:** Charles Hixson  
**Telephone Number:** 724-836-1400 ext 136  
**Fax Number:** 724-838-9455  
**Email Address:** chixson@stoneconcrete.com

Item Number	Quantity	Unit of Measure	Description	BRAND BID	Unit Price	Total
1	550	EACH	NUDURA 6" STANDARD FORM UNIT OR EQUAL Per Specification 3.1.1.1	Nudura	\$73.55	\$40,452.50
2	100	EACH	NUDURA 6" 90 DEGREE CORNER FORM OR EQUAL Per Specification 3.1.1.1	Nudura	\$36.80	\$3,680.00
3	150	EACH	6" FORM LOCK Per Specification 3.1.4.1	Nudura	\$9.95	\$1,492.50
4	40	EACH	4" PROTECTIVE TAPE Per Specification 3.1.4.2	Nudura	\$5.20	\$208.00
5	2	EACH	1" FIBRE TAPE Per Specification 3.1.4.3	Nudura	\$5.35	\$10.70
6	50	EACH	LOW EXPANSION SPRAY FOAM Per Specification 3.1.4.4	Nudura	\$17.10	\$855.00
7	25	EACH	FOAM GUN CLEANER Per Specification 3.1.4.5	Nudura	\$14.40	\$360.00

			Description	BRAND BID	Unit Price	Total
			FOAM GUN Per Specification 3.1.4.6	Nudura	\$60.30	\$1,507.50
			NUDURAL VERTICAL JOINT CLIP OR EQUAL Per Specification 3.1.4.7	Nudura	\$0.90	\$900.00
10	50	EACH	NUDURA 11.25" X 16' PREBUCK OR EQUAL Per Specification 3.1.3	Nudura	\$154.35	\$7,717.00
11	200	EACH	NUDURA 1.5" L-ANGLE FOR PREBUCK OR EQUAL Per Specification 3.1.3	Nudura	\$13.00	\$2,600.00
12	2	EACH	2" SCREWS W/ WASHER (AT LEAST 1,000 PER UNIT) Per Specification 3.1.4.8	Nudura	\$139.60	\$279.20
13	5	EACH	NUDURA SQ. TUBE BRACING 10' - 20 SETS OR EQUAL Per Specification 3.1.5	Nudura	\$6,531.00	\$32,655.00
14	60	EACH	NUDURA ONE SERIES OUTSIDE 90 DEGREE CORNER OR EQUAL Per Specification 3.1.2	Nudura	\$27.70	\$1,662.00

Item Number	Quantity	Unit of Measure	Description	BRAND BID	Unit Price	Total
15	50	EACH	NUDURA ONE SERIES MULTI FORM TIE OR EQUAL - at least 95 pcs/unit Per Specification 3.1.2	Nudura	\$144.90	\$7,245.00
16	10	EACH	NUDURA ONE SERIES CORNER BRACKET 10' OR EQUAL Per Specification 3.1.4.12	Nudura	\$91.95	\$919.50
17	5	EACH	NUDURA ONE SERIES METAL JIG OR EQUAL Per Specification 3.1.4.13	Nudura	\$273.70	\$1,368.50
18	200	EACH	NUDURA UNASSEMBLED STANDARD FORM OR EQUAL Per Specification 3.1.1	Nudura	\$65.45	\$13,090.00
19	400	EACH	NUDURA ONE SERIES PLYPAN 18" X 8' OR EQUAL Per Specification 3.1.2	Nudura	\$100.30	\$40,120.00
20	5	EACH	NUDURA PLYPAN REPL. INSERTS - AT LEAST 2400 PCS/UNIT OR EQUAL Per Specification 3.1.4.9	Nudura	\$800.85	\$4,004.25
21	50	EACH	10" SLIDE IN WEB - 100 PCS/BOX Per Specification 3.1.4.10	Nudura	\$110.00	\$5,500.00
			<b>Total</b>			\$172,688.15

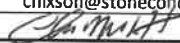
VENDOR NAME	Stone & Company
VENDOR ADDRESS	P. O. Box 776 606 McCormick Ave. Connellsville, PA 15425
PHONE #	724-836-1400 Ext. 136 Charles Hixson or Neil Mason 724-889-7409
EMAIL	chixson@stoneconcrete.com or nmason@stoneconcrete.com
SIGNATURE	

**NUDURA INC.  
LIMITED WARRANTY**

NUDURA® Inc. (“NUDURA”), as Manufacturer of the Insulated Concrete Form products (the “Products”), which form part of the NUDURA Integrated Building Technology, warrants the owner of the structure built with the Products (the “Customer”) against defects in materials as indicated hereunder.

If the Products, or any portion thereof, because of defects in materials, as established by the report of an independent engineer designated by NUDURA (the “Independent Engineer’s Report”) (a) fail to provide insulation to the R-Value level of R22 due to settlement, compression or deterioration as a result of gravity, normal soil pressures or normal climatic conditions, or (b) fail to obtain a sound transmission class (“STC”) rating of at least 50 (when constructed as a wall assembly in accordance with NUDURA’s wall assembly testing to ASTM E336) ( for concrete cores of 6 inches (152 mm) or greater ) or 42 ( for 4 inch (102 mm) concrete cores) due to settlement, compression or deterioration as a result of gravity, normal soil pressures or normal climatic conditions (the “Defective Products”), NUDURA will then at its sole discretion either (i) replace the Defective Products; or (ii) pay to the Customer an amount equal to 100% of the purchase price of the Defective Products.

For the purposes of this Warranty, the purchase price of the Defective Products shall be the original purchase price paid by the Customer for the Defective Products which are the subject of the Warranty claim and shall be exclusive of all other costs, including labour, to remove the existing Defective Products and replace with new Products.

**IMPORTANT: FOR THIS WARRANTY TO BE EFFECTIVE, ALL THE FOLLOWING CONDITIONS MUST BE SATISFIED, AS REASONABLY DETERMINED BY NUDURA:**

Claims made under this Warranty must be made in writing to NUDURA at the address below within the life of the Warranty for a particular claim as described above. NUDURA shall be permitted a reasonable opportunity to inspect the site with respect to which a claim is made in order to determine if this Warranty is applicable.

This LIMITED WARRANTY is given subject to the following conditions, failing which, this Warranty shall be null and void:

- The Products must have been purchased from NUDURA or an authorized Distributor, for installation in Canada or the United States;
- This Warranty is transferable to the first subsequent owner of the structure upon written notice of transfer of ownership being sent to NUDURA within 120 days after transfer of ownership;
- The Customer has notified NUDURA of the Warranty claim in writing;
- Defects in the Products are not caused by misuse, accidents, alterations, failure to follow instructions, or any other act which is not the fault of NUDURA;
- The Products must be properly installed and the concrete must be fully consolidated within the Products in accordance with applicable Building Code Standards, and NUDURA’s installation procedures by a NUDURA trained installer who is in possession of a NUDURA trained installer wallet card;
- Defects in the Products must not result from issue, abuse, improper storage, improper installation or repair, alteration or modification to the Products, defects in the surface coverings, including waterproofing membranes, or due to unusual physical elements including climatic conditions;
- Only NUDURA authorized coating must be applied to the Products;
- Only NUDURA authorized hardware must be used to assemble the Products or to affix other products on the Products.
- 

In addition, this LIMITED WARRANTY does not cover:

- The size and shape of the Products, which may vary by up to .75% of their specifications;
- The adhesiveness and external appearance of the coating applied to the Products;
- The items which may be temporarily or permanently affixed or attached to the Products and the hardware used to affix or attach such items;
- The costs relating to the installation, dismantling or reinstallation of the Products or Defective Products;
- Exposure of the Products to fire, water, excessive humidity or to floods.



Any claim pursuant to this LIMITED WARRANTY shall be made by the Customer in writing and shall be forwarded within thirty (30) days following the discovery of the defect to the Original Selling Point, with a copy to your supplier

NUDURA DISCLAIMS EXPRESSLY ALL IMPLIED WARRANTIES AND CONDITIONS, INCLUDING ANY IMPLIED WARRANTY OF MERCHANTABILITY OR WARRANTY OF FITNESS FOR A PARTICULAR PURPOSE, EXCEPT TO THE EXTENT PROHIBITED BY APPLICABLE LAW.

Neither the Distributor nor reseller of the Products is entitled to make any warranty, express, implied or otherwise to the Customer with respect to the Products.

The installation of the Products must be carried out or supervised by a recognized NUDURA trained installer and in accordance with the NUDURA Installation Manual. A NUDURA trained installer is a person who: (i) has attended the appropriate NUDURA Basic Installation Training Course; (ii) passed the quiz with a grade of at least 70%; (iii) successfully completed a minimum of two projects using NUDURA Products and has demonstrated to the Distributor his or her ability during actual installations to competently install the NUDURA Products; (iv) has a signed Distributor Sign Off Sheet from the Distributor; and (v) has a trained installer wallet card issued by NUDURA. Further, the Distributor shall take all reasonable measures in order that all Customers be provided with the NUDURA Installation Manual and inform the Customers of the necessity of using appropriate care when installing the NUDURA Products.

All users of the Products recognize that NUDURA and its affiliated entities have no control over the installation or workmanship used in the assembly or the installation of the Products, whether by a recognized NUDURA trained installer or by an unauthorized installer. Therefore, NUDURA and its affiliated entities shall not be held liable for any general, special, direct, indirect or consequential damages, including bodily harm, which may be suffered by any person, including without limitation, the installer, contractor, architect, engineer, homeowner, building owner or the Customer due to the use, assembly or installation of the Products. In no event shall NUDURA's liability exceed the provisions of this Warranty.

This LIMITED WARRANTY is offered solely by NUDURA.

This LIMITED WARRANTY constitutes the entire agreement among NUDURA, the Distributors or resellers of the Products and the Customer. This LIMITED WARRANTY gives the Customer specific legal rights and the Customer may have other rights which may vary from country to country, from state to state, or from province to province.



# PRODUCT CATALOGUE

*Nudura insulated concrete forms, insulation products and accessories*



# CONTENTS

Introduction	3
Product Innovation	4
Product Series	5
Nudura ICF Series	
Assembled Forms:	
Standard Form	6
90° Form	7
45° Form	8
Taper Top Form	9
Brick Ledge Form	10
Radius Form	11
T-Form	12
Unassembled Forms:	
Standard Form	13
Taper Top Form	14
Double Sided Taper Top Form	15
Brick Ledge Form	16
Double Sided Brick Ledge Form	17
Brick Ledge & Taper Top Form	18
Optimizer Form	19
One Series	20-21
Plus Series	
XR35	22
Nudura Plus Forms	23
R-Value Inserts	24
Integrated Series	
HYDROFOAM®	25
THERMOFOAM®	26
HOMEGA®	27
Nudura Form Accessories	28
Nudura Accessories	29-33
Nudura Alignment System	34-35
Nudura Tall Wall Adapter Kit	36
Notes	37-38



# 1-800-CONCRETE STONE & COMPANY

*"The One Stop Shop"*

## Redi-Mix Concrete - 724-836-1400 x2

- *Serving Southwestern PA, and North Central WV State, Commercial, Residential Mix Designs:*
- *Front Discharge Mixers*
- *Concrete Pumping Division*
- *Integral Colored Concrete*
- *Exposed Aggregate Mixes*
- *Technician Rentals*



## Builder's Supply - 724-836-1400 x3

- *Tri-Axle/Dump Truck Aggregate Deliveries*
- *Sand, Stone, Landscaping Materials for Pick Up*
- *Concrete Sealers, Cleaners*
- *Wire Mesh, Rebar, Angle Iron*
- *Marshalltown, Bon Tools Masonry Tools*
- *Concrete Block, Colored Split Face Block*
- *Rockwood Retaining Wall Block*
- *Mortar, Quikrete, Portland Cement*
- *Geotextiles, Steel Decking, Trench Drains*
- *Eldorado, StoneCraft, Veneer Stone*
- *Nudura Insulated Concrete Forms*
- *Color Hardeners, Release Agents, Stains*
- *Overlays, Concrete Stamp Rentals*



## Precast Products - 724-836-1400 x4

- *Manholes, Risers, Cones*
- *Inlets, Catch Basins*
- *Concrete Drains, Steel Grating*
- *Redi-Rock Retaining Walls*
- *2'x2'x6' Yard Block, Bin Blocks*
- *Jersey Barriers, Parking Curbs*
- *Precast Steps*



## Lumber & Hardware

- *Connellsville, PA - 724-628-2200*
- *Irwin, PA - 724-672-4081*

## Kitchen & Bath Design - 724-672-4080

- *Irwin, PA - Stoney's Kitchen & Bath*

[stoneconcrete.com](http://stoneconcrete.com)

[stoneyskitchenandbath.com](http://stoneyskitchenandbath.com)



# STONE & COMPANY

## BUILDER'S SUPPLY



**724-672-4081**

10249 GARNET LANE, IRWIN PA 15642  
MON. - FRI. 7AM - 4:30PM, SAT. 7AM - 12PM

**FAST, FRIENDLY, RELIABLE SERVICE WITH COMPETITIVE PRICING. STOP BY AND GIVE US A TRY!**



ALSO LOCATED AT:  
606 MCORMICK AVE  
CONNELLSVILLE, PA 15425

**SHOP LOCAL FOR THE BRANDS YOU TRUST IN OUR FULLY REMODELED BUILDER'S SUPPLY**

- ALL LUMBER NEEDS
- CONCRETE & MASONRY
- EXTERIOR BUILDING PRODUCTS
- ROOFING
- DECKING & RAILING
- MOULDINGS
- INSULATION
- HARDWARE
- PLUMBING
- ELECTRICAL
- PAINT (INCLUDING VALSPAR MIXING)
- LAWN & GARDEN
- SCREWS & FASTENERS





## Nudura ICFs are a proven method of providing you a better alternative to traditional building methods

Buildings today demand reliable, energy efficient and eco-friendly building envelopes that provide superior performance benefits to minimize energy costs, reducing carbon emissions, and maximizing property value. Nudura structures offer superior strength, disaster resilience, sound and fire-resistance, these are why the design community, developers, and contractors across the world continue to choose Nudura's insulated concrete forms and insulation products as a proven alternative to traditional building methods.

Nudura products provide design professionals, architects, homeowners and contractors the freedom and versatility to design and build a structure the way it was envisioned. Building with Nudura gives you the opportunity to build faster and more efficient, while offering your clients an eco-friendly structure with substantial benefits that contribute to long-term energy savings. When specifying Nudura you can assure your customers that you are using the best building solution available today. Nudura is now proudly part of Tremco Construction Products Group (CPG).

## The Tremco CPG Difference



Tremco CPG brings together Tremco Incorporated's Commercial Sealants & Waterproofing and Roofing & Building Maintenance operating divisions; Dryvit Systems, Inc.; Nudura Inc.; Willseal; Weatherproofing Technologies, Inc. and Weatherproofing Technologies Canada, Inc. Speed up construction or renovation. Simplify installation. Extend the construction season. A Tremco Construction Product Group (CPG) single-source building envelope means more for everyone – more satisfied contractors, more comfortable occupants or tenants, and more efficient structures and cost-effective operation for owners.



### Faster Construction Time

Lightweight, fast-curing and prefabricated products mean less occupant disruption, faster return to service, less revenue lost – and no call-backs.



### Any Look You Want

A wide range of colors and finishes like brick, granite, metals, stucco and more provide maximum flexibility in your roof and façade aesthetic.



### Stronger and More Resilient

Our systems are designed for maximum durability, many with service lives far surpassing that of competing systems.



### Leak-Free Performance

Products provide maximum protection from air, moisture and thermal infiltration – and are performance tested in our one-of-a-kind Sustainable Building Solutions Test Facility.



### Cost Effective for the Long Term

A broad range of products can fit any project budget – but our energy efficiency and maintenance solutions can also help you ensure cost-effective ownership and operation for the long term.



### Better Insulated

Industry-leading brands provide solutions for more efficient building construction and operation, and exceed strict energy codes for insulation.



### One Point of Contact

Our products and systems are backed by industry-leading warranties – all from a single point of contact. We can also help with everything from asset management to diagnostics to installer training.



### Leading Edge Sustainability

Our building solutions help you meet green building standards like Net Zero, Living Building Challenge, Passive House and more.



Nudura ICFs are manufactured with industry leading patented technologies that are exclusive to Nudura, offering you a full line of innovative products designed to provide superior energy efficiency, greater strength, and sound resistance. Our building envelope provides an affordable eco-friendly building solution that allows you to build faster, more efficiently and offers substantial benefits over traditional construction.

## Innovation makes us the solution to better building.

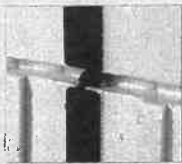

- **DURALOK Technology**® - Securely locks forms into place with a triple tooth interlock eliminating the need to wire or glue forms, resulting in reduced labor costs during installation. Once the forms are stacked together a continuous full height-fastening strip ensures wall heights are always accurate, compared to other forms without full height-fastening which can cause wall height shrinkage once concrete is placed. DURALOK Technology® makes Nudura the strongest in the industry.

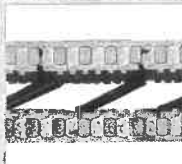

- **DURAFOLD Technology**® - Patented hinged web technology allows the entire Nudura form line up to fold and ship flat, allowing for 40% more product on a truck compared to other Insulated Concrete Form products. Once on-site, simply unfold and stack.

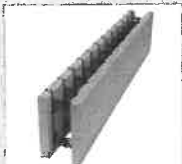

- **DURAMAX Technology**® - Largest standard form on the market measuring 96" x 18" (2438mm x 457mm). Our 96" (2438mm) form creates 60% fewer joints in the wall compared to other wall systems and allows installers the ability to place 12 sq.ft. (1.11m<sup>2</sup>) of wall area with one block.



- **4-WAY REVERSIBLE System** - Patented foam interlock allows the form to be 4-way reversible, eliminating left and right corners, which helps speed up the building process and reduces product waste on-site.

Watch our Innovation Video  
at [nudura.com/innovation](http://nudura.com/innovation)



 nudura<sup>icf</sup>  
—series—

The Nudura ICF Series is the leader in Insulated Concrete Form Innovation and technology and offers users the ability to combine a variety of products during the building process. The Nudura ICF Series offers unique advantages over other products currently on the market.

- DURAMAX Technology®
- DURAFOLD Technology®
- DURALOK Technology®
- The 4-Way Reversible System

 one<sup>1</sup>  
—series—

The One Series was the industry's first multi-link form system that enables the creation of a fully exposed concrete surface that extends to the face of a standard Nudura form panel. This offers builders and architects unmatched versatility for projects designed to use ICFs. At the core of this innovative line is our DURA MULTI-LINK® Technology, a newly designed tie that enables the builder to create custom multi-sided form combinations for a variety of commercial and residential building projects.

 plus<sup>+</sup>  
—series—

The Plus Series product line introduces an innovative way for designers and engineers to build their own R-value. The Plus Series product line offers the ability to optimize R-Value with thermal mass to provide significant energy savings for building owners. The Nudura Plus Series allows professionals the ability to meet new installation requirements with one product.

 integrated<sup>↗</sup>  
—series—

The Integrated Series from Nudura combines building envelope products that work in conjunction with our line of Insulated Concrete Forms to provide maximum energy efficiency. Each Integrated Series product has been manufactured to install quickly and efficiently and replaces many traditional forms of insulation products that are far more labor intensive.

 Preventol®  
By LANXESS  
Energizing Chemistry

Preventol® is an "imidacloprid" based Termite Insecticide Treatment that can be added at the manufacturing stage to any Nudura ICF products. Preventol® is formally evaluated by the ICC-Evaluation Service for Termite Resistance as an insect treatment designed for use in EPS Foam. (ESR-2918). (NOTE: Product option is only available from Nudura's Southern US Plant location per USA Code Requirements.)



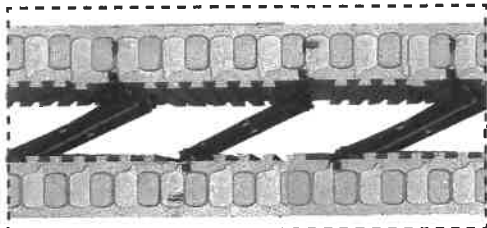
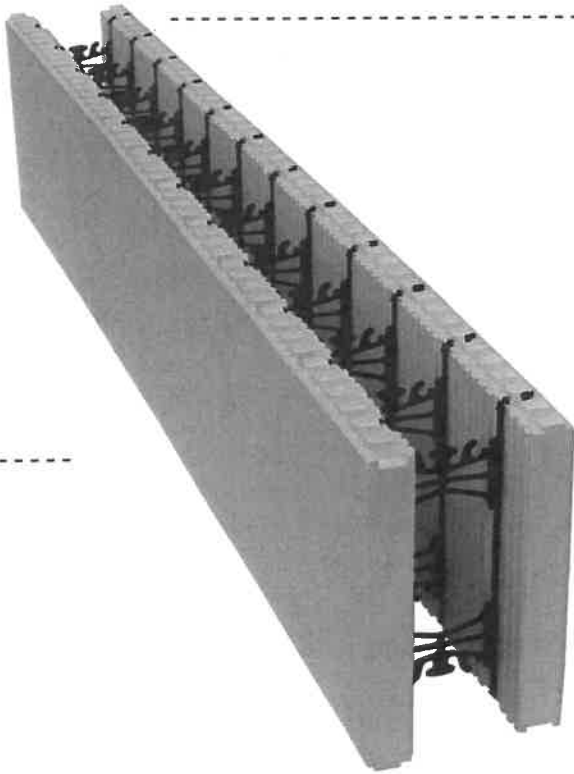

Close view of folding metal-hinged web

Assembled Product Shown Above

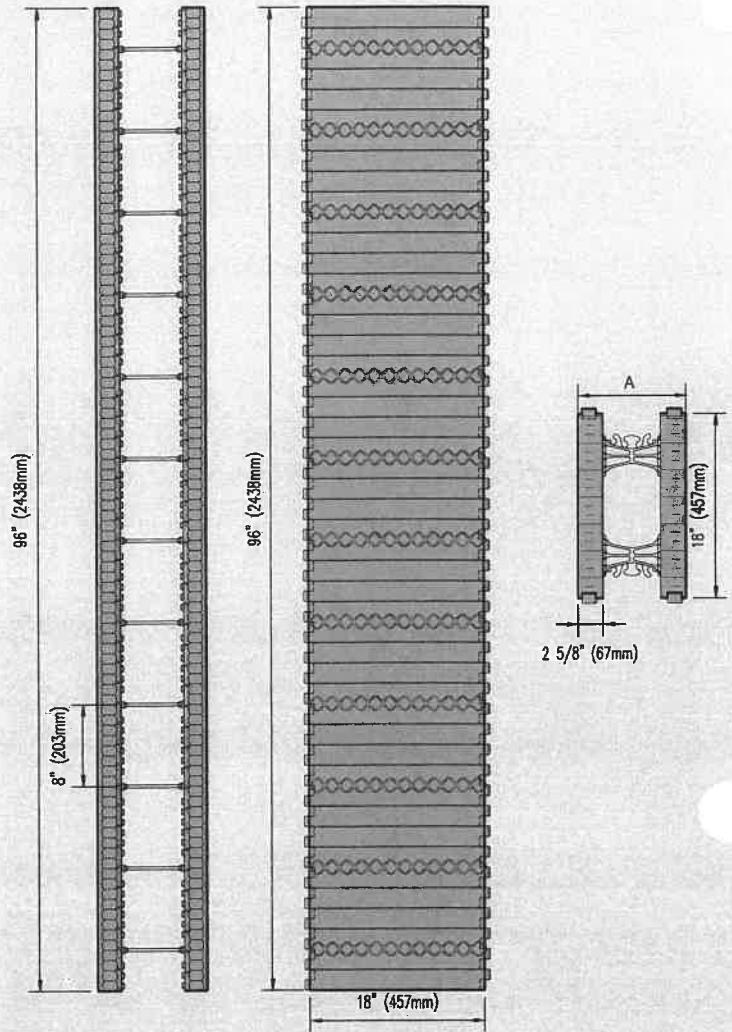

## MAY WE SUGGEST: FORM-LOCK

Used to maintain wall straightness. Other uses include wall alignment for vertical stack joints.

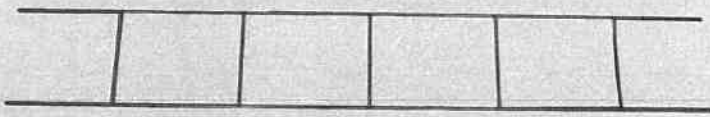

Available for 6" (150mm), 8" (200mm), 10" (250mm), 12" (300mm) Standard Forms.

Core Width	6" (150mm)	8" (200mm)	10" (250mm)	12" (300mm)
Length	10' (3m)	10' (3m)	10' (3m)	10' (3m)
Qty./Bundle	10 PCS	10 PCS	10 PCS	10 PCS
Code #	NUS-ABLOK-06	NUS-ABLOK-08	NUS-ABLOK-10	NUS-ABLOK-12

Visit the Resource Center on Nudura's website ([nudura.com/resource-center](http://nudura.com/resource-center)) for design details, BIM library, installation links & more.

Refer to pages 28-33 for all related product accessories & tools. For additional information visit [nudura.com](http://nudura.com) or call 866-468-6299.

Core Width	4" (100mm)	6" (150mm)	8" (200mm)	10" (250mm)	12" (300mm)
Length	96" (2438mm)	96" (2438mm)	96" (2438mm)	96" (2438mm)	96" (2438mm)
Width A	9 1/4" (235mm)	11 1/4" (286mm)	13 1/4" (337mm)	15 1/4" (387mm)	17 1/4" (438mm)
Height	18" (457mm)	18" (457mm)	18" (457mm)	18" (457mm)	18" (457mm)
EPS Thickness	2 5/8" (67mm)	2 5/8" (67mm)	2 5/8" (67mm)	2 5/8" (67mm)	2 5/8" (67mm)
Qty./Bundle	3	3	3	3	3
Code #	NUS-10096-04	NUS-10096-06	NUS-10096-08	NUS-10096-10	NUS-10096-12

Units come assembled with folding, metal-hinged webs.

Webs are included with assembled forms.

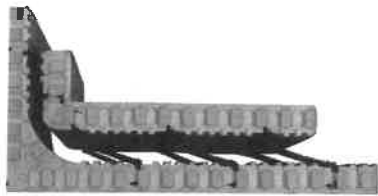
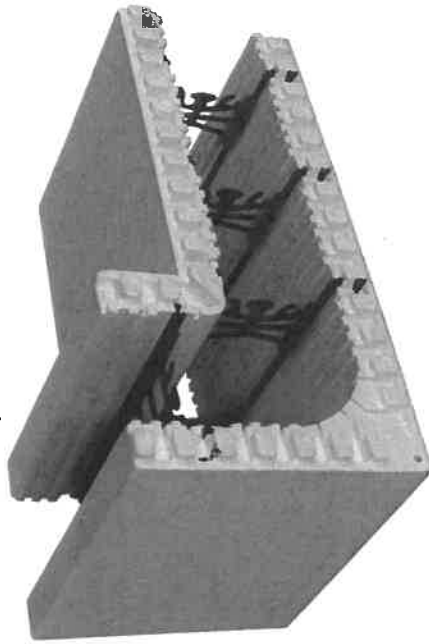

View of folding metal-hinged web and insert web for angled corner (included in order).

Assembled Product Shown Above

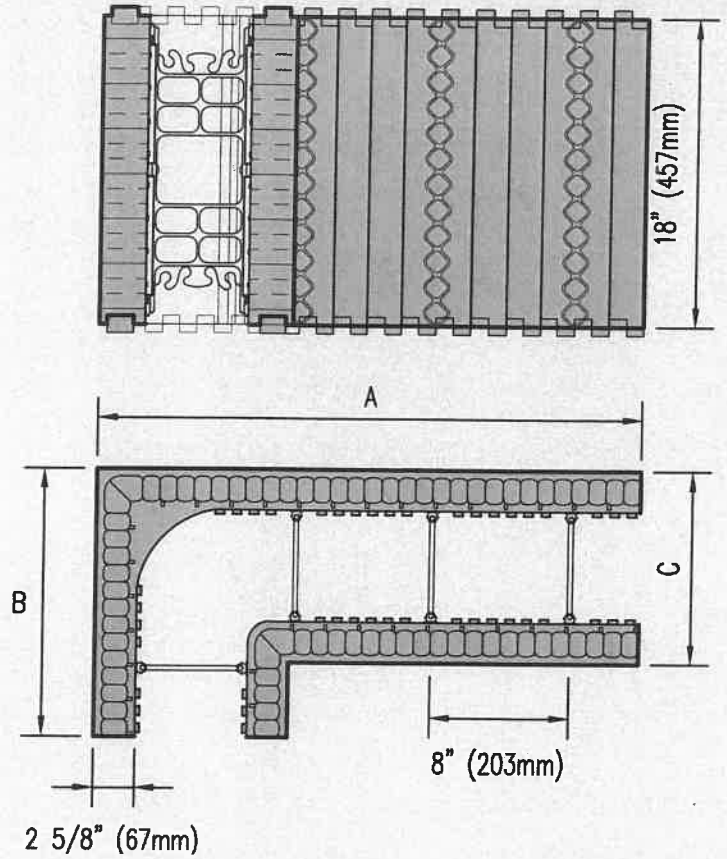

**MAY WE SUGGEST: Vertical Joint Clip**

**Vertical Joint Clip**

This metal clip is designed to connect the form together at the vertical joints. It replaces having to tie wire or tape forms together while providing a solid connection using minimal amount of labor to install.



Qty./Box	200 PCS
Code #	NUS-A0VJC-00

Core Width	4" (100mm)	6" (150mm)	8" (200mm)	10" (250mm)	12" (300mm)
<b>Length A</b>	31 5/8" (803mm)	31 5/8" (803mm)	33 5/8" (854mm)	35 5/8" (905mm)	37 5/8" (956mm)
<b>Length B</b>	15 5/8" (397mm)	15 5/8" (397mm)	17 5/8" (448mm)	19 5/8" (498mm)	21 5/8" (549mm)
<b>Width C</b>	9 1/4" (235mm)	11 1/4" (286mm)	13 1/4" (337mm)	15 1/4" (387mm)	17 1/4" (438mm)
<b>Height</b>	18" (457mm)	18" (457mm)	18" (457mm)	18" (457mm)	18" (457mm)
<b>Qty./Bundle</b>	6	6	6	4	4
<b>Code #</b>	NUS-10090-04	NUS-10090-06	NUS-10090-08	NUS-10090-10	NUS-10090-12

Units come assembled with folding, metal-hinged webs.

Visit the Resource Center on Nudura's website ([nudura.com/resource-center](http://nudura.com/resource-center)) for design details, BIM library, installation links & more.

Refer to pages 28-33 for all related product accessories & tools. For additional information visit [nudura.com](http://nudura.com) or call 866-468-6299.

Webs are included with assembled forms.

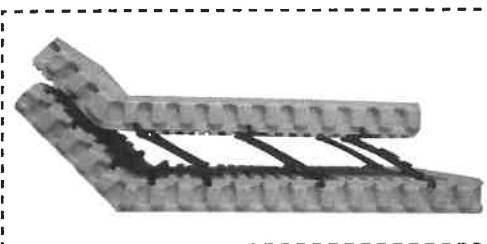
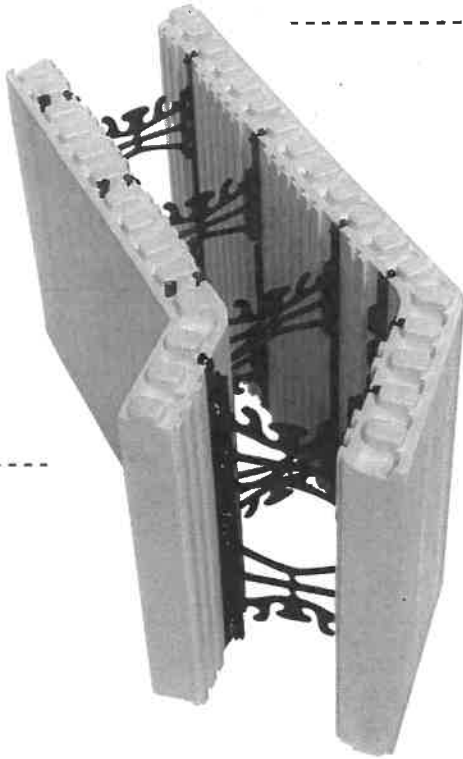

View of folding metal-hinged web and insert web for angled corner (included in order).

Assembled Product Shown Above

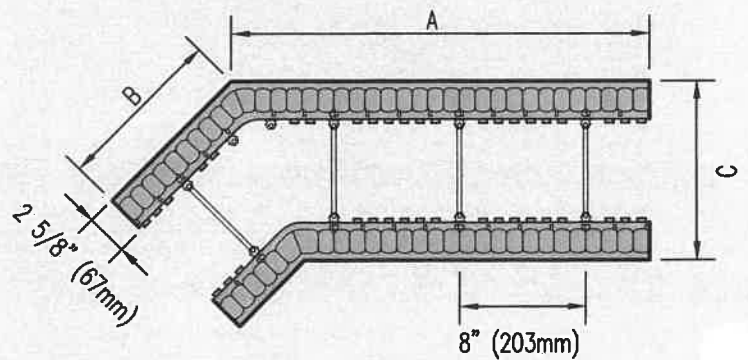
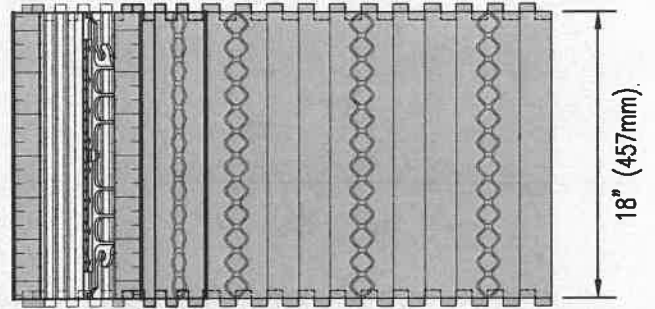

**MAY WE SUGGEST: Vertical Joint Clip**

**Vertical Joint Clip**

This metal clip is designed to connect the form together at the vertical joints. It replaces having to tie wire or tape forms together while providing a solid connection using minimal amount of labor to install.



Qty./Box	200 PCS
Code #	NUS-A0VIC-00

Visit the Resource Center on Nudura's website ([nudura.com/resource-center](http://nudura.com/resource-center)) for design details, BIM library, installation links & more.

Refer to pages 28-33 for all related product accessories & tools. For additional information visit [nudura.com](http://nudura.com) or call 866-468-6299.

Core Width	4" (100mm)	6" (150mm)	8" (200mm)	10" (250mm)	12" (300mm)
<b>Length A</b>	26 1/2" (673mm)	26 1/2" (673mm)	26 1/2" (673mm)	28 1/2" (724mm)	30 1/2" (775mm)
<b>Length B</b>	10 1/2" (267mm)	10 1/2" (267mm)	10 1/2" (267mm)	12 1/2" (318mm)	14 1/2" (368mm)
<b>Width C</b>	9 1/4" (235mm)	11 1/4" (286mm)	13 1/4" (337mm)	15 1/4" (387mm)	17 1/4" (438mm)
<b>Height</b>	18" (457mm)	18" (457mm)	18" (457mm)	18" (457mm)	18" (457mm)
<b>Qty./Bundle</b>	6	6	6	4	4
<b>Code #</b>	NUS-10045-04	NUS-10045-06	NUS-10045-08	NUS-10045-10	NUS-10045-12

Units come assembled with folding, metal-hinged webs.

Webs are included with assembled forms.

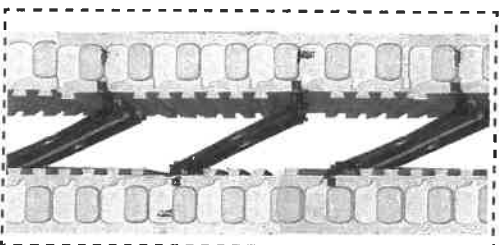
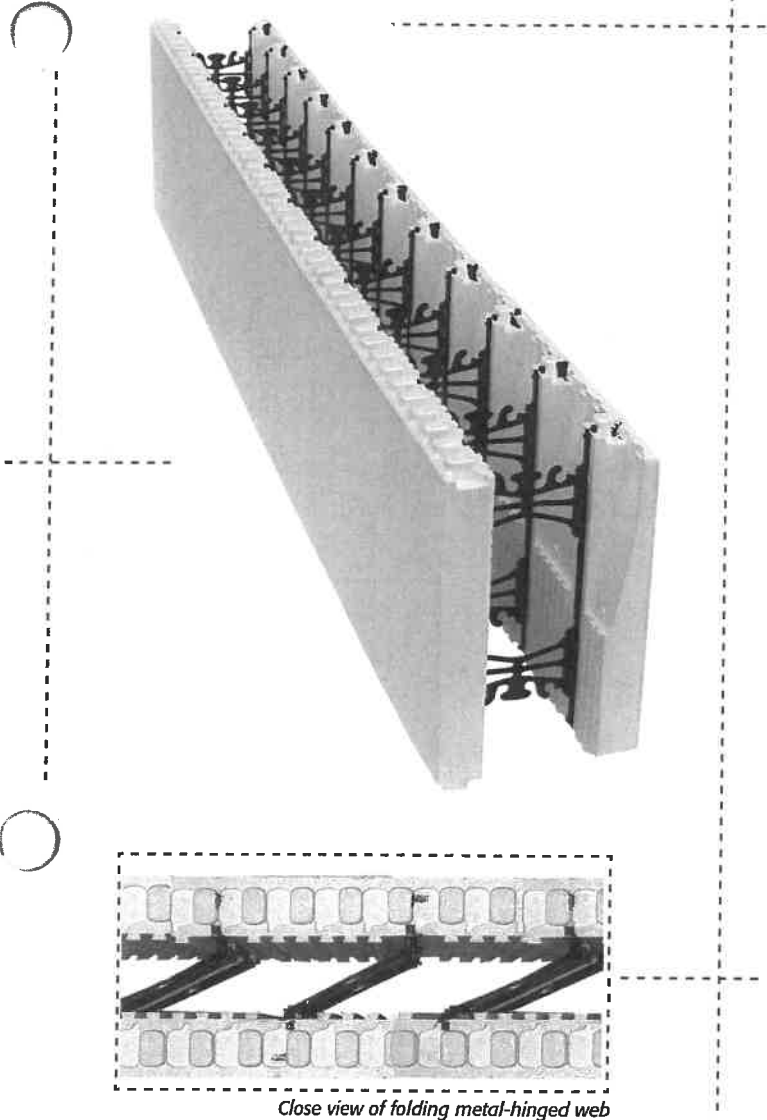

Close view of folding metal-hinged web

Assembled Product Shown Above

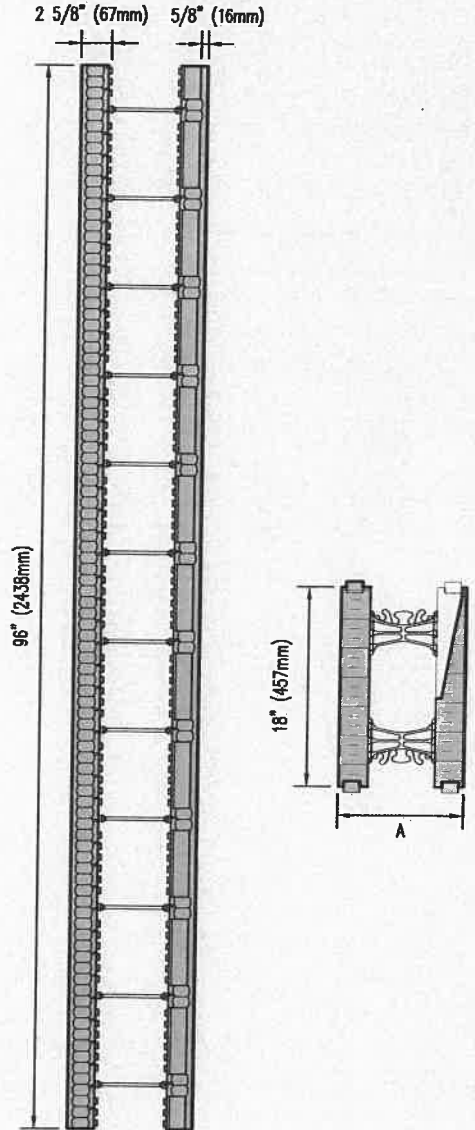

## MAY WE SUGGEST: Heavy Duty Tape

### 4" Heavy Duty Tape

Used for covering the interlock at the top of a wall to protect it from concrete getting into the interlock.



Qty./Box	24 PCS
Code #	NUS-ATPHD-04
Dimensions	4" x 72 Yd (96mm x 66m)

Visit the Resource Center on Nudura's website ([nudura.com/resource-center](http://nudura.com/resource-center)) for design details, BIM library, installation links & more.

Refer to pages 28-33 for all related product accessories & tools. For additional information visit [nudura.com](http://nudura.com) or call 866-468-6299.

Core Width	4" (100mm)	6" (150mm)	8" (200mm)	10" (250mm)	12" (300mm)
Overall Width A	9 1/4" (235mm)	11 1/4" (286mm)	13 1/4" (337mm)	15 1/4" (387mm)	17 1/4" (438mm)
Length - 96"		96" (2438mm)	96" (2438mm)		
Qty./Bundle		3	3		
Code #		NUS-10T96-06	NUS-10T96-08		

Webs are included with assembled units.

- Units come assembled with folding, metal-hinged webs.
- Only available as an unassembled Form Unit. Refer to page 14 for order information.



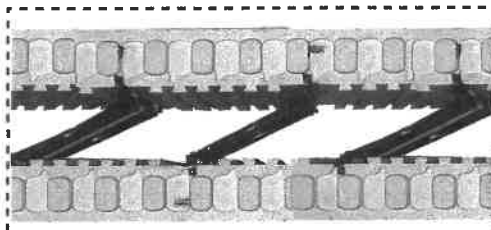
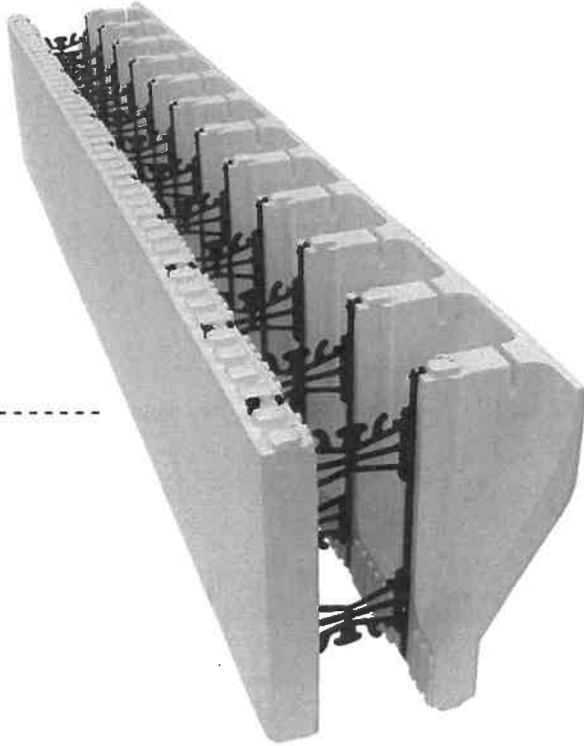

Close view of folding metal-hinged web

Assembled Product Shown Above

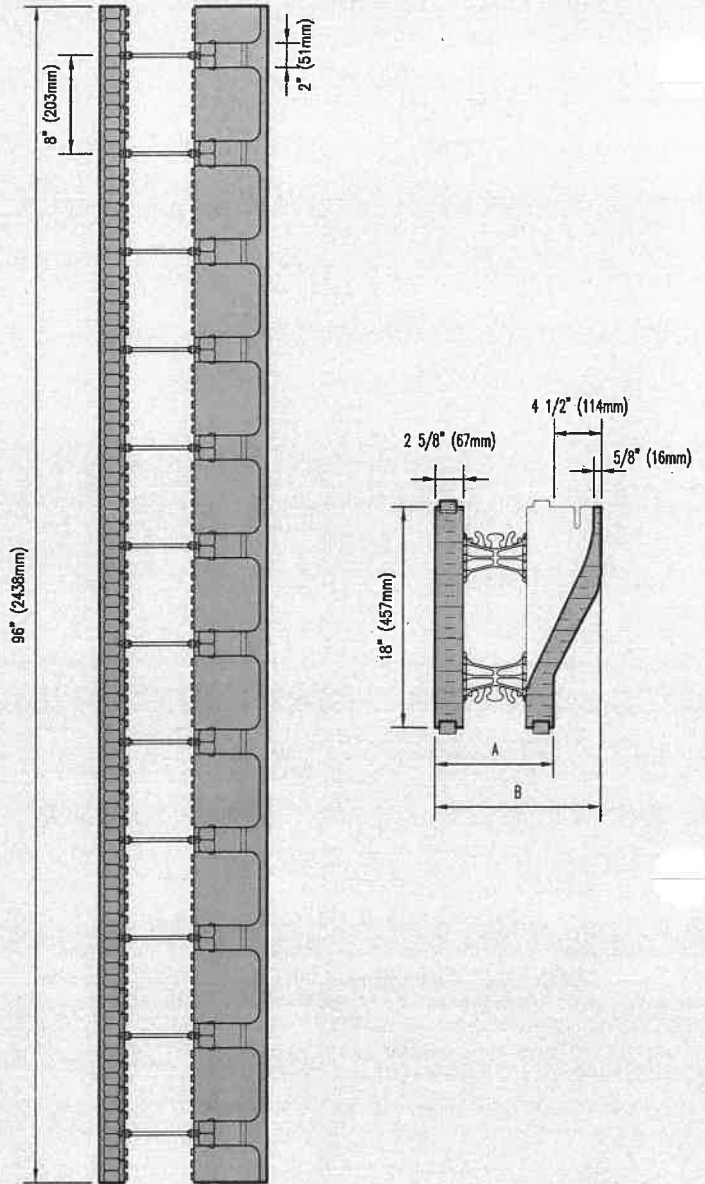

Assembled 96" (2438mm) Molded Brick Ledge Shown Above

## MAY WE SUGGEST: Brick Ledge Extension

### Brick Ledge Extension

Used for supporting standard brick or stone veneer finishes, when constructing brick ledges at corners, and can be installed to meet any elevation change or slope.

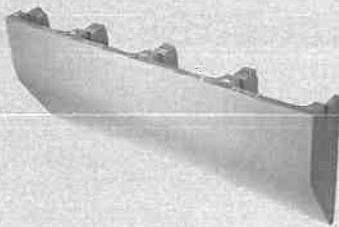

Qty./Bundle	14
Code #	NUS-ABLEX-00

Refer to page 28 for more order information.

Refer to pages 28-33 for all related product accessories & tools. For additional information visit nudura.com or call 866-468-6299.

Core Width	4" (100mm)	6" (152mm)	8" (203mm)	10" (250mm)	12" (300mm)
<b>Width A</b>		11 1/4" (268mm)			
<b>Width B</b>		15 3/4" (400mm)			
<b>Length - 96"</b>		96" (2438mm)			
<b>Qty./Bundle</b>		4			
<b>Code #</b>		NUS-10848-06			
Webs are included with assembled units.					
<b>Length - 96"</b>		96" (2438mm)			
<b>Qty./Bundle</b>		2			
<b>Code #</b>		NUS-10896-06			
Webs are included with assembled units.					

- Units come assembled with folding, metal-hinged webs.
- Only available as an unassembled Form Unit. Refer to page 16 for order info.

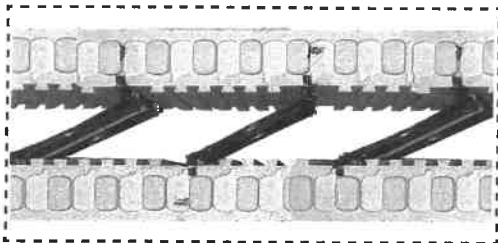
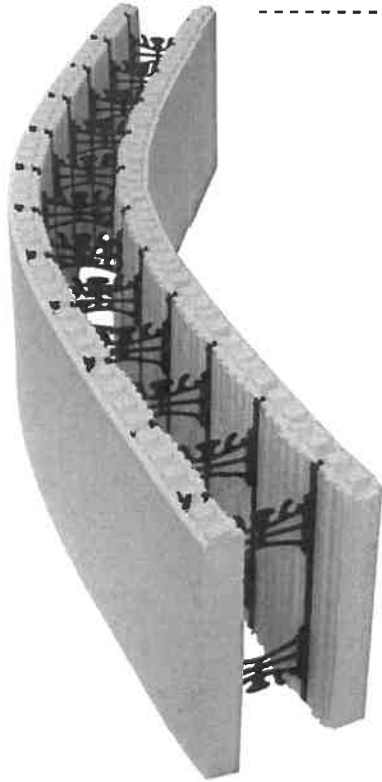

Close view of folding metal-hinged web

Assembled Product Shown Above

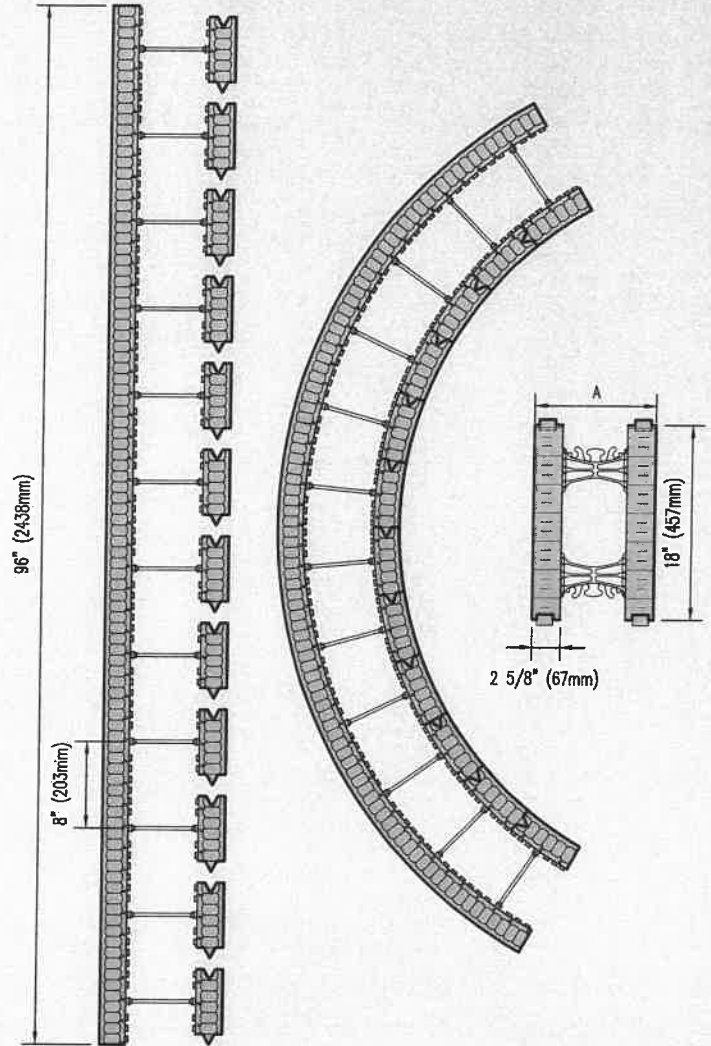

## MAY WE SUGGEST: NUBASE Parging Mix and Fiber Mesh

### NUBASE Parging Mix and Fiber Mesh

The parge mix is a dry cementitious product that is used to cover exposed EPS that is not covered by an exterior finish. Used in conjunction with Fiber Mesh. The Fiber Mesh gets embedded into the parge coat to give it strength.



**Parging Mix**  
Coverage - 75 sq ft (7m<sup>2</sup>)

Qty./Each | 1 BAG  
Code # | NUS-APARG-00



**Fiber Mesh**  
Coverage - 475 sq ft (44m<sup>2</sup>)

Qty./Each | 1 ROLL  
Code # | NUS-AMESH-00

Core Width	4" (100mm)	6" (150mm)	8" (200mm)	10" (250mm)	12" (300mm)
Length	96" (2438mm)	96" (2438mm)	96" (2438mm)	96" (2438mm)	96" (2438mm)
Width A	9 1/4" (235mm)	11 1/4" (286mm)	13 1/4" (337mm)	15 1/4" (387mm)	17 1/4" (438mm)
Height	18" (457mm)	18" (457mm)	18" (457mm)	18" (457mm)	18" (457mm)
Radius	Manufactured to Specifications.				
Qty./Bundle	Varies with radius size. Contact your local distributor for details.				
Code #	NUS-10RAD-04	NUS-10RAD-06	NUS-10RAD-08	NUS-10RAD-10	NUS-10RAD-12

Units come assembled with folding metal-hinged webs.

Refer to Nudura's Installation Manual for the Radius Form Calculator.

Visit the Resource Center on Nudura's website ([nudura.com/resource-center](http://nudura.com/resource-center)) for design details, BIM library, installation links & more.

Refer to pages 28-33 for all related product accessories & tools. For additional information visit [nudura.com](http://nudura.com) or call 866-468-6299.

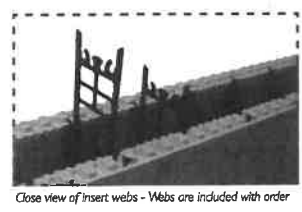
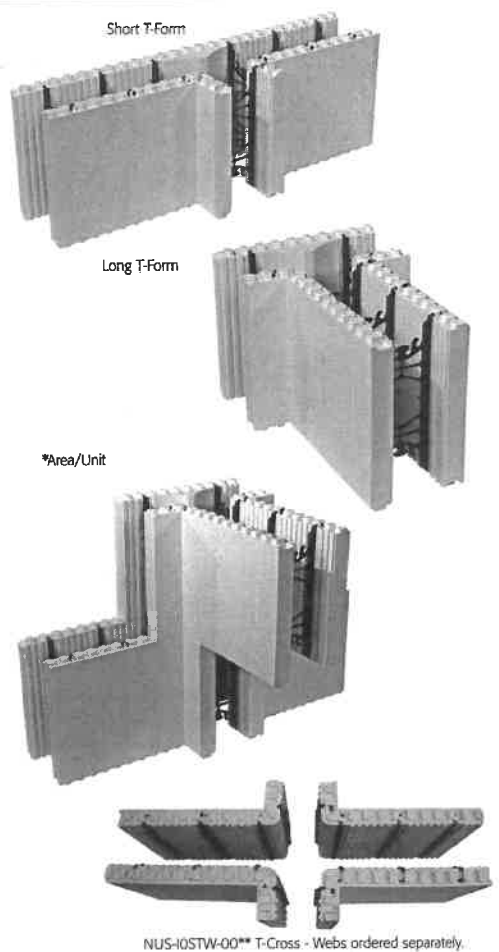

## Webs are Included - Site Assembly Required

Refer to pages 28-33 for all related product accessories & tools.  
For additional information visit nudura.com or call 866-468-6299.

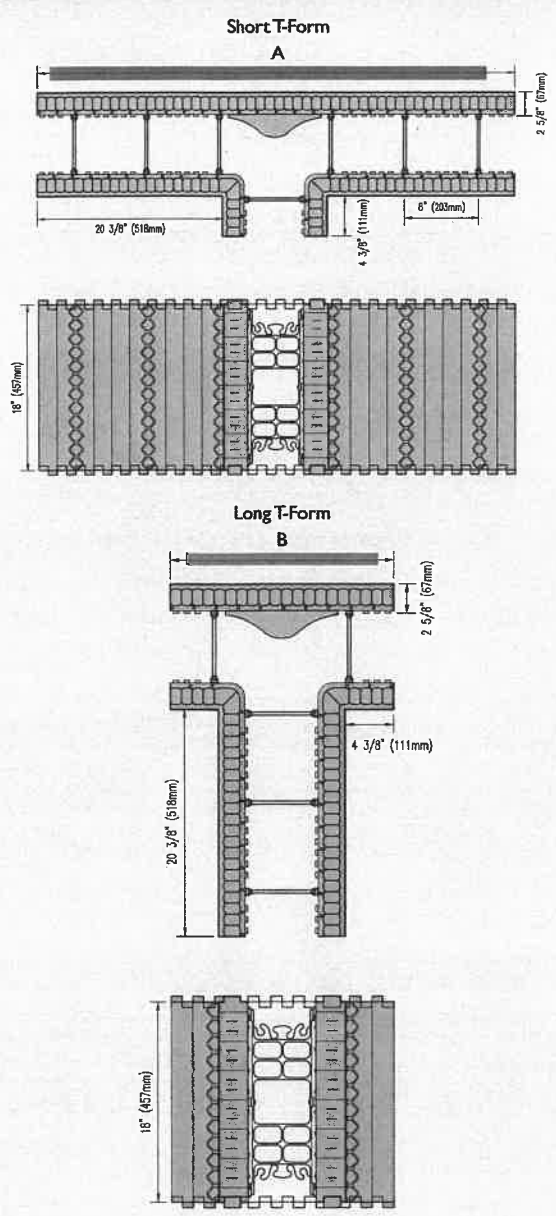

For more form dimensions refer to Nudura's Installation Manual.

## Bundle Includes 4 Courses - 2 Short and 2 Long T-Forms

**Main Wall** - represents the concrete core of the outside form  
**Interior Wall "T"** - represents the concrete core of the inside form that joins to the Main Wall

Core Width	Short T-Form Length (A)	Long T-Form Length (B)	Area/Unit*	Bundle Code #
6" (150mm)	20" (508mm)	20" (508mm)	12 ft <sup>2</sup> (1.115 m <sup>2</sup> )	NUS-I0T06-06
8" (200mm)	22" (559mm)	22" (559mm)	12 1/2 ft <sup>2</sup> (1.161m <sup>2</sup> )	NUS-I0T08-08

**\*\* Special Order:** Code # NUS-I0STW-00: T-Cross Form Unit Unassembled - 4 panels per T-Cross (4 T-Cross Form Units per bundle) - 32 webs required per bundle. Webs ordered separately. Refer to next page for web order information.

Short T-Form Main Exterior Wall Length. Webs are included. Long T-Form Main Exterior Wall Length. Webs are included.

\*Area/Unit - a unit represents one Short T-Form and one Long T-Form connected together forming 2 courses (reference photo above).

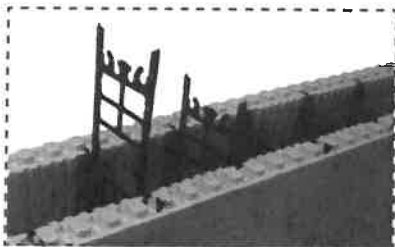
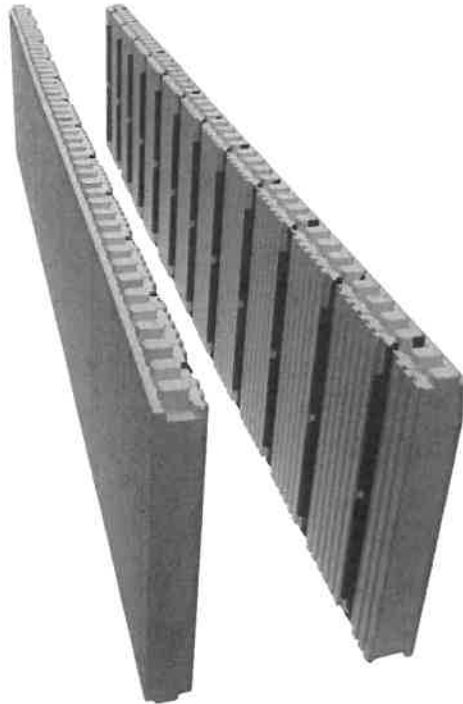

Close view of insert webs - available in 4"-12" (100-300mm) sizes

Unassembled Product Shown Above

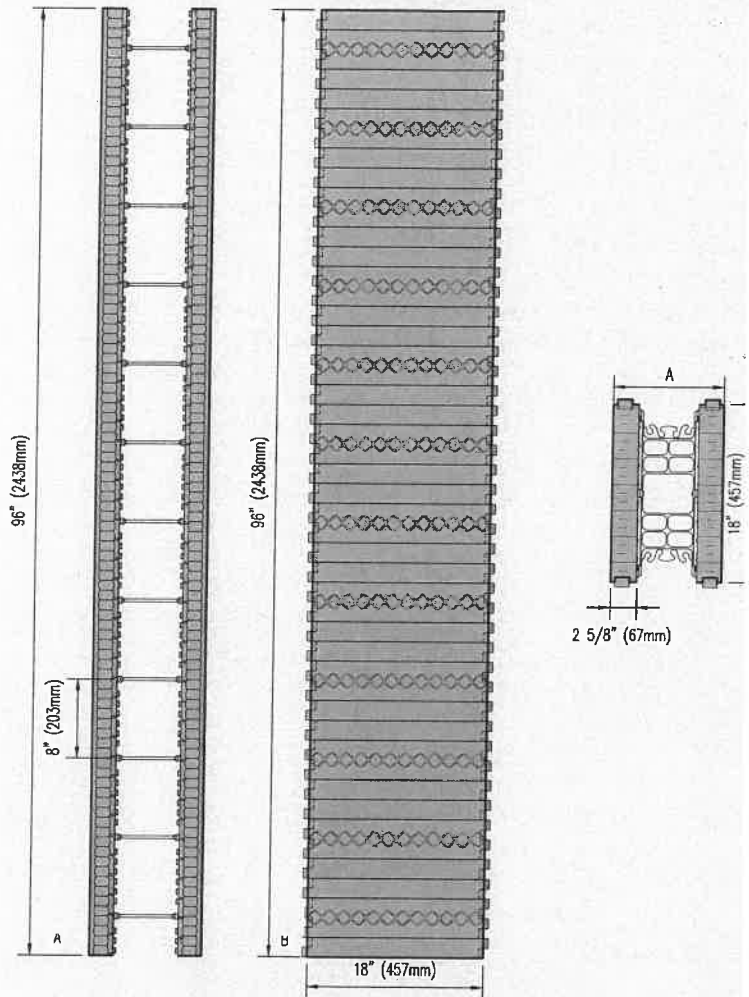

## Insert Webs (Ordered Separately)

### Small Box

Core Width	4" (100mm)	6" (150mm)	8" (200mm)	10" (250mm)	12" (300mm)
Qty./Box	100	100	100	100	100
Code #	NUS-IWEBS-04	NUS-IWEBS-06	NUS-IWEBS-08	NUS-IWEBS-10	NUS-IWEBS-12

### Large Box

Core Width	4" (100mm)	6" (150mm)	8" (200mm)	10" (250mm)	12" (300mm)
Qty./Box	957	655	465	388	295
Code #	NUS-IWEBL-04	NUS-IWEBL-06	NUS-IWEBL-08	NUS-IWEBL-10	NUS-IWEBL-12

Core Width	4" (100mm)	6" (150mm)	8" (200mm)	10" (250mm)	12" (300mm)
Length	96" (2438mm)	96" (2438mm)	96" (2438mm)	96" (2438mm)	96" (2438mm)
Width A	9 1/4" (235mm)	11 1/4" (286mm)	13 1/4" (337mm)	15 1/4" (387mm)	17 1/4" (438mm)
Height	18" (457mm)	18" (457mm)	18" (457mm)	18" (457mm)	18" (457mm)
Qty./Bundle	Includes: 6 Standard Panels (3 pairs per bundle)				
Code #	NUS-IOPAN-00	NUS-IOPAN-00	NUS-IOPAN-00	NUS-IOPAN-00	NUS-IOPAN-00
Web Qty. Req'd/Bundle	36	36	36	36	36

- Units come unassembled.
- Insert webs required per bundle - refer to web order chart on left.

Visit the Resource Center on Nudura's website ([nudura.com/resource-center](http://nudura.com/resource-center)) for design details, BIM library, installation links & more.

Refer to pages 28-33 for all related product accessories & tools. For additional information visit [nudura.com](http://nudura.com) or call 866-468-6299.



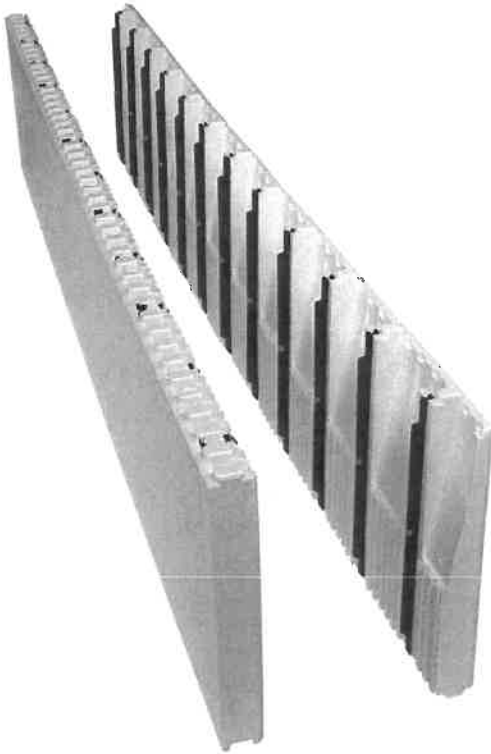

Close view of insert webs - available in 4"-12" (100-300mm) sizes

Unassembled Product Shown Above

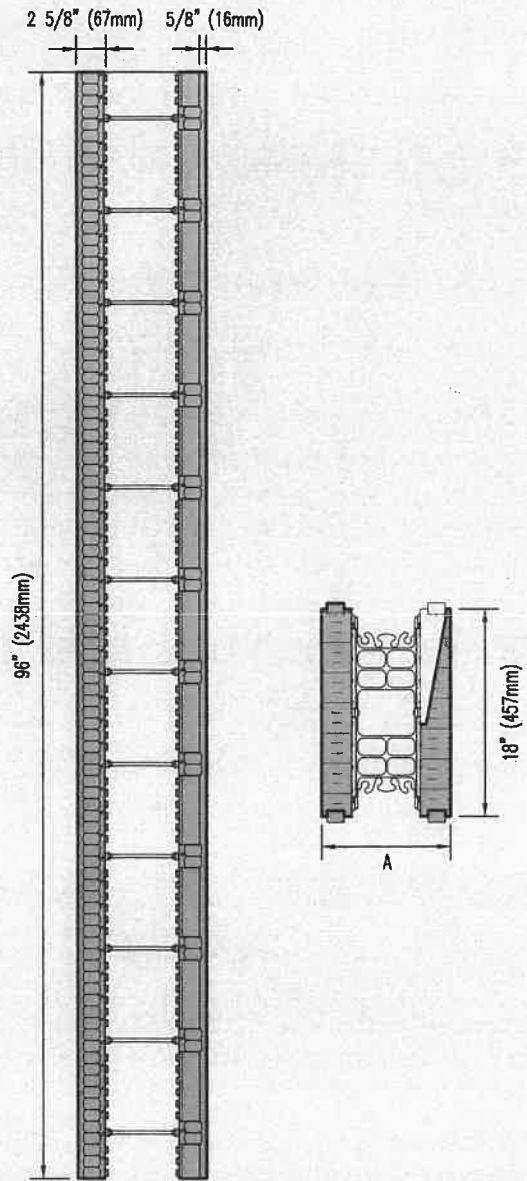

## Insert Webs (Ordered Separately)

### Small Box

Core Width	4" (100mm)	6" (150mm)	8" (200mm)	10" (250mm)	12" (300mm)
Qty./Box	100	100	100	100	100
Code #	NUS-IWEBS-04	NUS-IWEBS-06	NUS-IWEBS-08	NUS-IWEBS-10	NUS-IWEBS-12

### Large Box

Core Width	4" (100mm)	6" (150mm)	8" (200mm)	10" (250mm)	12" (300mm)
Qty./Box	957	655	465	388	295
Code #	NUS-IWEBL-04	NUS-IWEBL-06	NUS-IWEBL-08	NUS-IWEBL-10	NUS-IWEBL-12

Core Width	4" (100mm)	6" (150mm)	8" (200mm)	10" (250mm)	12" (300mm)
<b>Overall Width A</b>	9 1/4" (235mm)	11 1/4" (286mm)	13 1/4" (337mm)	15 1/4" (387mm)	17 1/4" (438mm)
<b>Length - 96"</b>	96" (2438mm)	96" (2438mm)	96" (2438mm)	96" (2438mm)	96" (2438mm)
<b>Qty./Bundle</b>	Includes: 3 Taper Top Panels & 3 Standard Panels				
<b>Code #</b>	NUS-I0T96-00	NUS-I0T96-00	NUS-I0T96-00	NUS-I0T96-00	NUS-I0T96-00
<b>Web Qty. Req'd/Bundle</b>	36	36	36	36	36

Visit the Resource Center on Nudura's website ([nudura.com/resource-center](http://nudura.com/resource-center)) for design details, BIM library, installation links & more.

Refer to pages 28-33 for all related product accessories & tools. For additional information visit [nudura.com](http://nudura.com) or call 866-468-6299.

- Units come unassembled.
- Insert webs required per bundle - refer to web order chart on left.

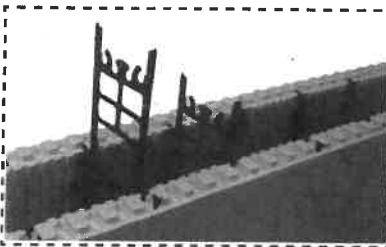
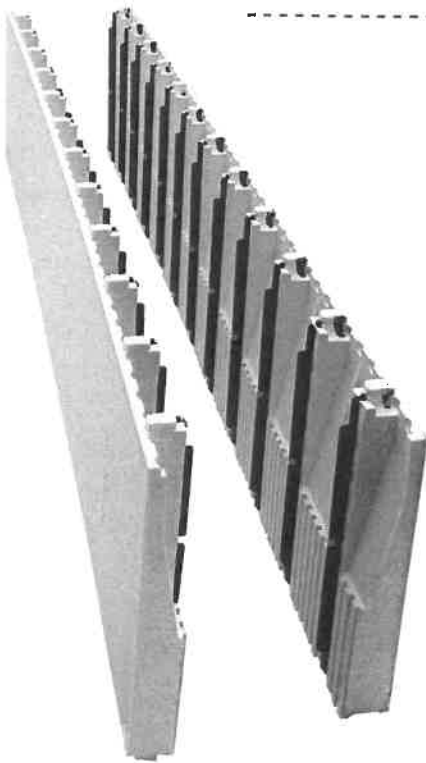

Close view of insert webs - available in 4"-12" (100-300mm) sizes

Unassembled Product Shown Above

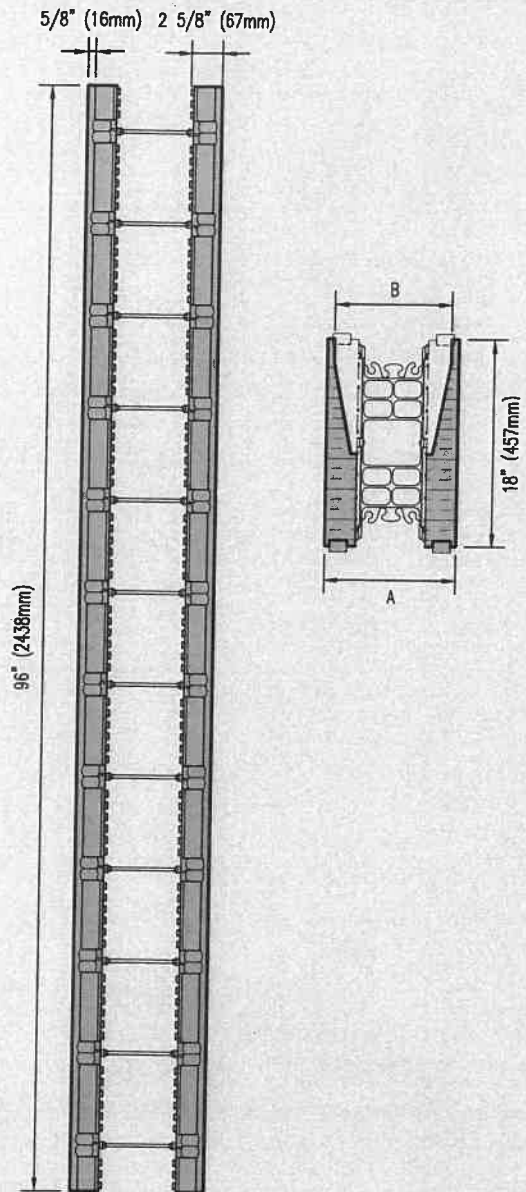

## Insert Webs (Ordered Separately)

### Small Box

Core Width	4" (100mm)	6" (150mm)	8" (200mm)	10" (250mm)	12" (300mm)
Qty./Box	100	100	100	100	100
Code #	NUS-IWEBS-04	NUS-IWEBS-06	NUS-IWEBS-08	NUS-IWEBS-10	NUS-IWEBS-12

### Large Box

Core Width	4" (100mm)	6" (150mm)	8" (200mm)	10" (250mm)	12" (300mm)
Qty./Box	957	655	465	388	295
Code #	NUS-IWEBL-04	NUS-IWEBL-06	NUS-IWEBL-08	NUS-IWEBL-10	NUS-IWEBL-12

Core Width	4" (100mm)	6" (150mm)	8" (200mm)	10" (250mm)	12" (300mm)
<b>Overall Width A</b>	9 1/4" (235mm)	11 1/4" (286mm)	13 1/4" (337mm)	15 1/4" (387mm)	17 1/4" (438mm)
<b>Overall Width B</b>	8" (203mm)	10" (254mm)	12" (305mm)	14" (356mm)	16" (406mm)
<b>Length - 96"</b>	96" (2438mm)	96" (2438mm)	96" (2438mm)	96" (2438mm)	96" (2438mm)
<b>Qty./Bundle</b>	Includes: 6 Taper Top Panels				
<b>Code #</b>	NUS-I0D96-00	NUS-I0D96-00	NUS-I0D96-00	NUS-I0D96-00	NUS-I0D96-00
<b>Web Qty. Req'd/Bundle</b>	36	36	36	36	36

- Units come unassembled.
- \*Available assembled - 3 units/bundle (webs included):
  - 6" (150mm) - NUS-I0D96-06
  - 8" (200mm) - NUS-I0D96-08
- Insert webs required per bundle - refer to web order chart on left.

Visit the Resource Center on Nudura's website ([nudura.com/resource-center](http://nudura.com/resource-center)) for design details, BIM library, installation links & more.

Refer to pages 28-33 for all related product accessories & tools. For additional information visit [nudura.com](http://nudura.com) or call 866-468-6299.

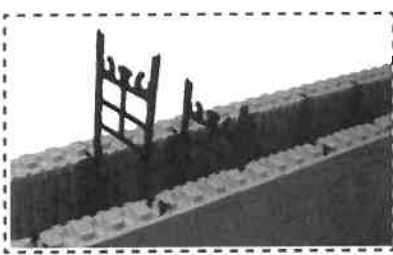
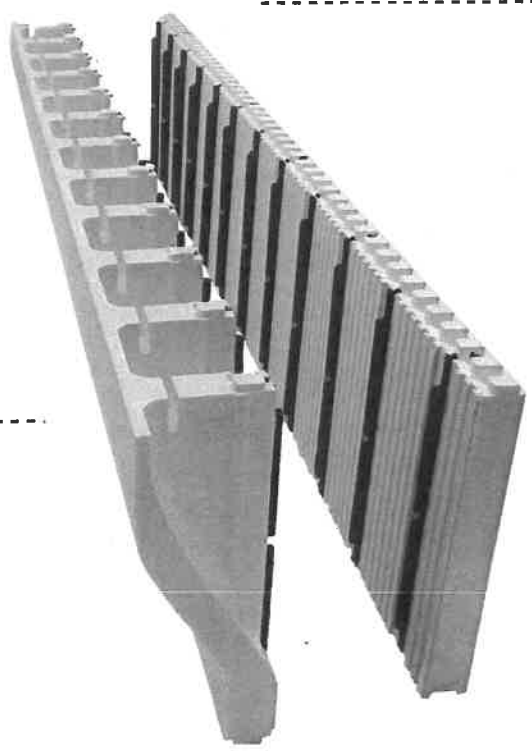

Close view of insert webs - available in 4"-12" (100-300mm) sizes

Unassembled Product Shown Above

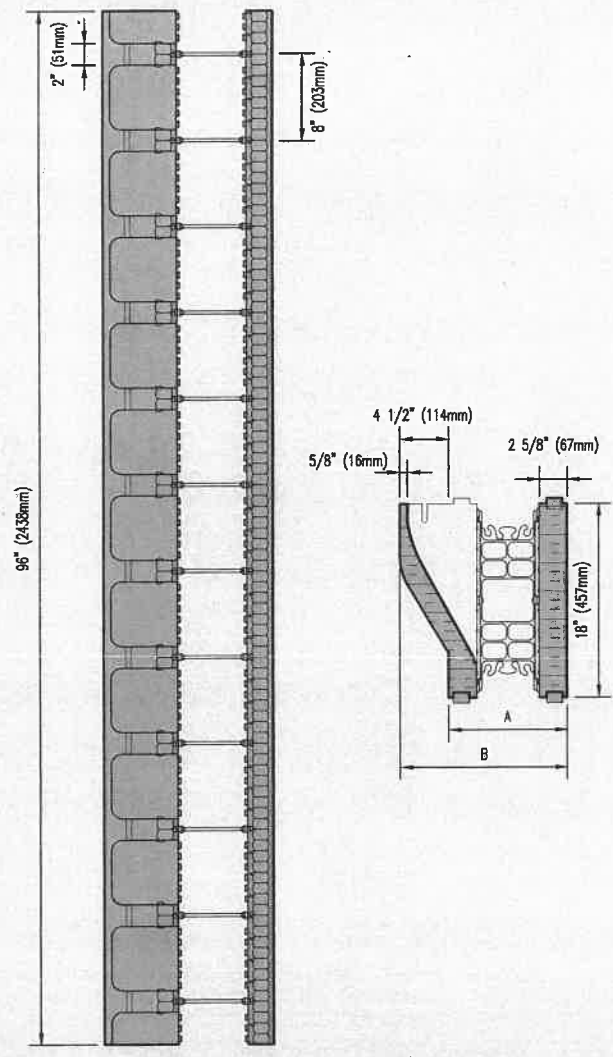

Unassembled 96" (2438mm) Molded Brick Ledge Shown Above

## Insert Webs (Ordered Separately)

### Small Box

Core Width	4" (100mm)	6" (150mm)	8" (200mm)	10" (250mm)	12" (300mm)
Qty./Box	100	100	100	100	100
Code #	NUS-IWEBS-04	NUS-IWEBS-06	NUS-IWEBS-08	NUS-IWEBS-10	NUS-IWEBS-12

### Large Box

Core Width	4" (100mm)	6" (150mm)	8" (200mm)	10" (250mm)	12" (300mm)
Qty./Box	957	655	465	388	295
Code #	NUS-IWEBL-04	NUS-IWEBL-06	NUS-IWEBL-08	NUS-IWEBL-10	NUS-IWEBL-12

Visit the Resource Center on Nudura's website ([nudura.com/resource-center](http://nudura.com/resource-center)) for design details, BIM library, installation links & more.

Refer to pages 28-33 for all related product accessories & tools. For additional information visit [nudura.com](http://nudura.com) or call 866-468-6299.

Core Width	4" (100mm)	6" (150mm)	8" (200mm)	10" (250mm)	12" (300mm)
Overall Width A	9 1/4" (235mm)	11 1/4" (286mm)	13 1/4" (337mm)	15 1/4" (387mm)	17 1/4" (438mm)
Overall Width B	13 3/4" (349mm)	15 3/4" (400mm)	17 3/4" (451mm)	19 3/4" (502mm)	21 3/4" (552mm)
48" requires one Brick Ledge Panel & one Standard Panel to assemble one form unit					
Length - 48"	48" (1219mm)	48" (1219mm)	48" (1219mm)	48" (1219mm)	48" (1219mm)
Qty./Bundle	Includes: 4 Brick Ledge Panels & 4 Standard Panels				
Code #	NUS-10B48-00	NUS-10B48-00	NUS-10B48-00	NUS-10B48-00	NUS-10B48-00
Web Qty. Req'd/Bundle	24	24	24	24	24
96" requires one Brick Ledge Panel & one Standard Panel to assemble one form unit					
Length - 96"	96" (2438mm)	96" (2438mm)	96" (2438mm)	96" (2438mm)	96" (2438mm)
Qty./Bundle	Includes: 2 Brick Ledge Panels & 2 Standard Panels				
Code #	NUS-10B96-00	NUS-10B96-00	NUS-10B96-00	NUS-10B96-00	NUS-10B96-00
Web Qty. Req'd/Bundle	24	24	24	24	24

- Units come unassembled.
- Insert webs required per bundle - refer to web order chart on left.

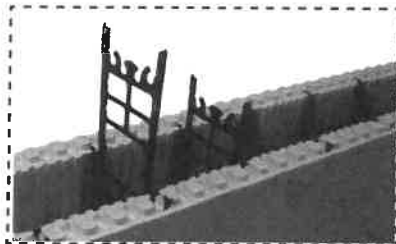
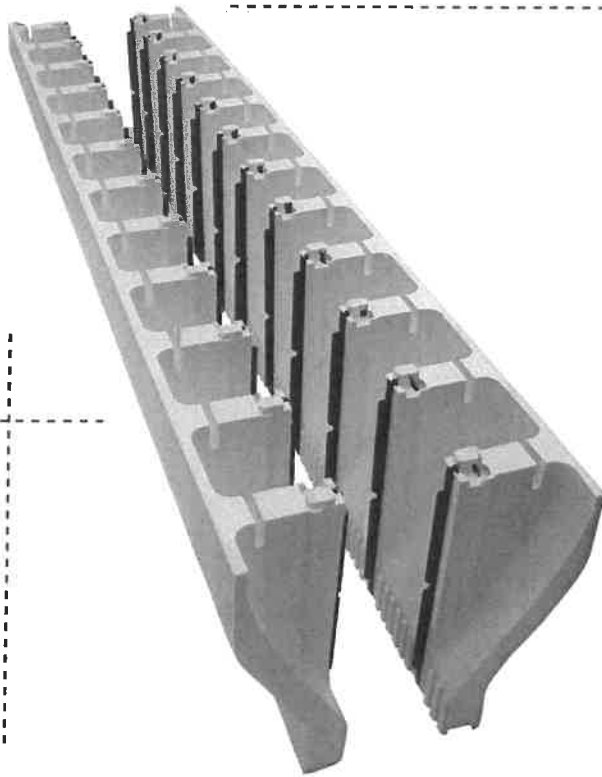

Close view of insert webs - available in 4"-12" (100-300mm) sizes

Unassembled Product Shown Above

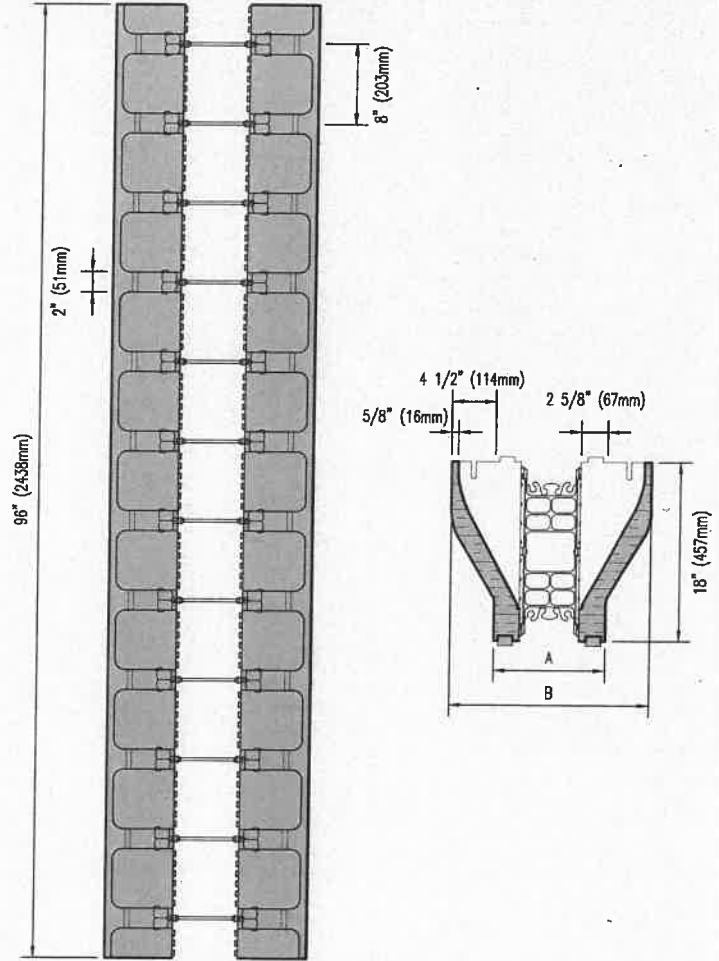

Unassembled 96" (2438mm) Double Sided Brick Ledge Shown Above

## Insert Webs (Ordered Separately)

### Small Box

Core Width	4" (100mm)	6" (150mm)	8" (200mm)	10" (250mm)	12" (300mm)
Qty./Box	100	100	100	100	100
Code #	NUS-IWEBS-04	NUS-IWEBS-06	NUS-IWEBS-08	NUS-IWEBS-10	NUS-IWEBS-12

### Large Box

Core Width	4" (100mm)	6" (150mm)	8" (200mm)	10" (250mm)	12" (300mm)
Qty./Box	957	655	465	388	295
Code #	NUS-IWEBL-04	NUS-IWEBL-06	NUS-IWEBL-08	NUS-IWEBL-10	NUS-IWEBL-12

Core Width	4" (100mm)	6" (150mm)	8" (200mm)	10" (250mm)	12" (300mm)
Overall Width A	9 1/4" (235mm)	11 1/4" (286mm)	13 1/4" (337mm)	15 1/4" (387mm)	17 1/4" (438mm)
Overall Width B	18 1/4" (463mm)	20 1/4" (514mm)	22 1/4" (565mm)	24 1/4" (616mm)	26 1/4" (667mm)
48" requires two Brick Ledge Panels (BRI-P) to assemble one double sided unit					
Length - 48"	48" (1219mm)	48" (1219mm)	48" (1219mm)	48" (1219mm)	48" (1219mm)
Qty./Bundle	Includes: 4 Brick Ledge Panels & 4 Standard Panels				
Code #	NUS-IOB48-00	NUS-IOB48-00	NUS-IOB48-00	NUS-IOB48-00	NUS-IOB48-00
Web Qty. Req'd/Bundle	24	24	24	24	24
96" requires two Brick Ledge Panels (BR96-P) to assemble one double sided unit					
Length - 96"	96" (2438mm)	96" (2438mm)	96" (2438mm)	96" (2438mm)	96" (2438mm)
Qty./Bundle	Includes: 2 Brick Ledge Panels & 2 Standard Panels				
Code #	NUS-IOB96-00	NUS-IOB96-00	NUS-IOB96-00	NUS-IOB96-00	NUS-IOB96-00
Web Qty. Req'd/Bundle	24	24	24	24	24

Visit the Resource Center on Nudura's website ([nudura.com/resource-center](http://nudura.com/resource-center)) for design details, BIM library, installation links & more.

Refer to pages 28-33 for all related product accessories & tools. For additional information visit [nudura.com](http://nudura.com) or call 866-468-6299.

- Units come unassembled.
- Insert webs required per bundle - refer to web order chart on left.



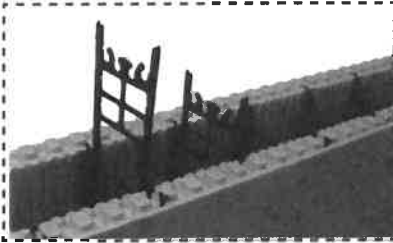
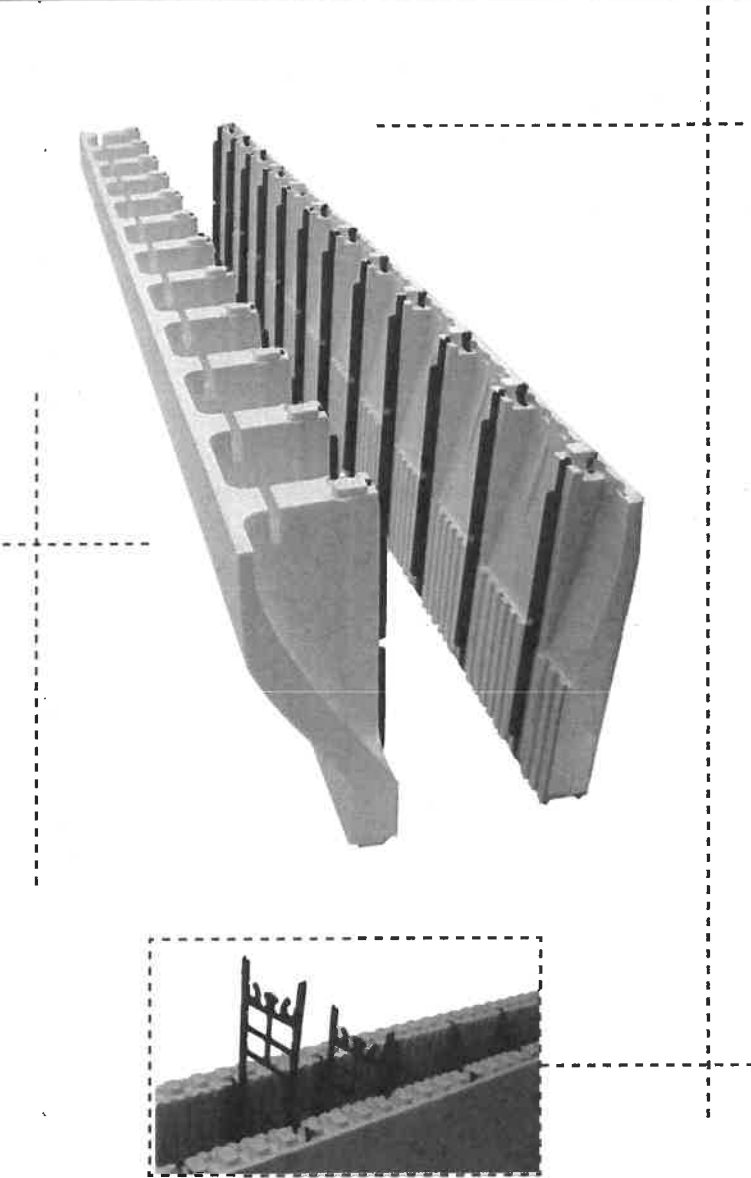

Close view of insert webs - available in 4"-12" (100-300mm) sizes

Unassembled Product Shown Above

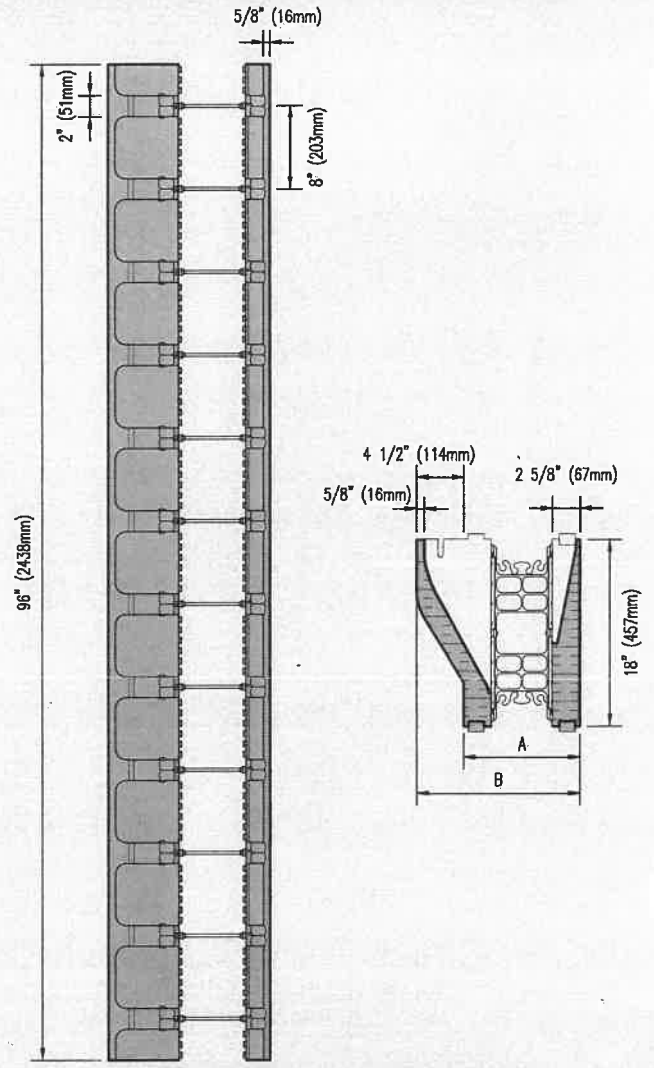

Unassembled 96" (2438mm) Brick Ledge and Taper Top Shown Above

## Insert Webs (Ordered Separately)

### Small Box

Core Width	4" (100mm)	6" (150mm)	8" (200mm)	10" (250mm)	12" (300mm)
Qty./Box	100	100	100	100	100
Code #	NUS-IWEBL-04	NUS-IWEBL-06	NUS-IWEBL-08	NUS-IWEBL-10	NUS-IWEBL-12

### Large Box

Core Width	4" (100mm)	6" (150mm)	8" (200mm)	10" (250mm)	12" (300mm)
Qty./Box	957	655	465	388	295
Code #	NUS-IWEBL-04	NUS-IWEBL-06	NUS-IWEBL-08	NUS-IWEBL-10	NUS-IWEBL-12

Core Width	4" (100mm)	6" (150mm)	8" (200mm)	10" (250mm)	12" (300mm)
<b>Overall Width A</b>	9 1/4" (235mm)	11 1/4" (286mm)	13 1/4" (337mm)	15 1/4" (387mm)	17 1/4" (438mm)
<b>Overall Width B</b>	13 3/4" (349mm)	15 3/4" (400mm)	17 3/4" (451mm)	19 3/4" (502mm)	21 3/4" (552mm)
96" requires two Brick Ledge Panels (BRI-P) & one Taper Top Panel (TT96-P) to assemble one unit					
Length - 48"	48" (1219mm)	48" (1219mm)	48" (1219mm)	48" (1219mm)	48" (1219mm)
Qty./Bundle	Includes: 4 Brick Ledge Panels w/ 4 Standard Panels & 3 Taper Top Panels w/ 3 Standard Panels				
Code #	NUS-I0B48-00 & NUS-I0T96-00	NUS-I0B48-00 & NUS-I0T96-00	NUS-I0B48-00 & NUS-I0T96-00	NUS-I0B48-00 & NUS-I0T96-00	NUS-I0B48-00 & NUS-I0T96-00
Web Qty. Req'd/Bundle	60	60	60	60	60
96" requires one Brick Ledge Panel (BR96-P) & one Taper Top Panel (TT96-P) to assemble one unit					
Length - 96"	96" (2438mm)	96" (2438mm)	96" (2438mm)	96" (2438mm)	96" (2438mm)
Qty./Bundle	Includes: 2 Brick Ledge Panels w/ 2 Standard Panels & 3 Taper Top Panels w/ 3 Standard Panels				
Code #	NUS-I0B96-00 & NUS-I0T96-00	NUS-I0B96-00 & NUS-I0T96-00	NUS-I0B96-00 & NUS-I0T96-00	NUS-I0B96-00 & NUS-I0T96-00	NUS-I0B96-00 & NUS-I0T96-00
Web Qty. Req'd/Bundle	60	60	60	60	60

Visit the Resource Center on Nudura's website ([nudura.com/resource-center](http://nudura.com/resource-center)) for design details, BIM library, installation links & more.

Refer to pages 28-33 for all related product accessories & tools. For additional information visit [nudura.com](http://nudura.com) or call 866-468-6299.

- Units come unassembled.
- Insert webs required per bundle - refer to web order chart on left.

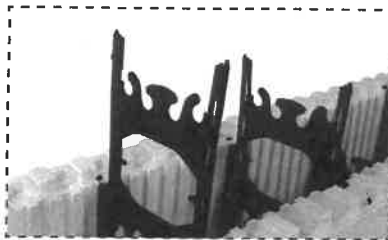
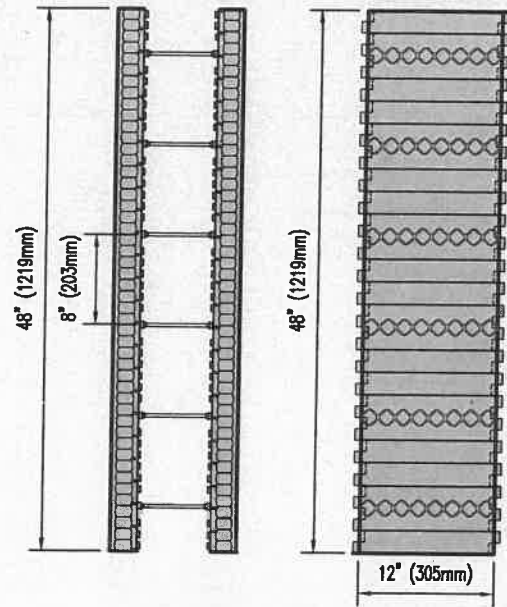
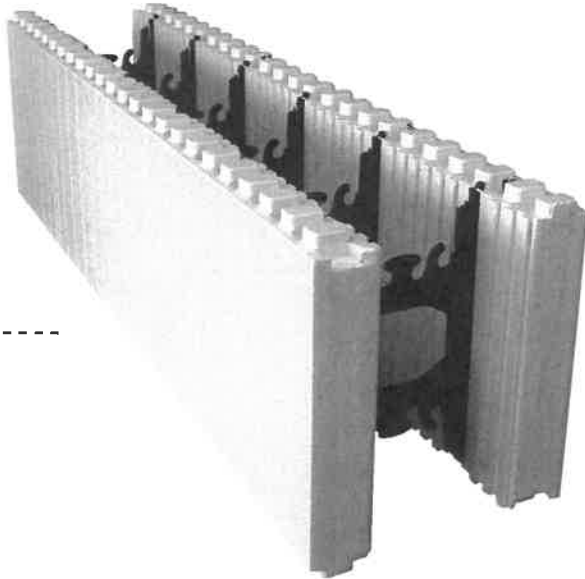

Close view of insert webs - available in 6"-12" (150-300mm) sizes

Product Shown Assembled Above

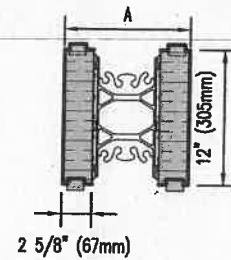

## Insert Webs (Ordered Separately)

Core Width	4" (100mm)	6" (150mm)	8" (200mm)	10" (250mm)	12" (300mm)
Qty./Box		120	120	84	84
Code #		NUS-IOWEB-06	NUS-IOWEB-08	NUS-IOWEB-10	NUS-IOWEB-12

Core Width	4" (100mm)	6" (150mm)	8" (200mm)	10" (250mm)	12" (300mm)
Length		48" (1219mm)	48" (1219mm)	48" (1219mm)	48" (1219mm)
Overall Width A		11 1/4" (286mm)	13 1/4" (337mm)	15 1/4" (387mm)	17 1/4" (438mm)
Height		12" (300mm)	12" (300mm)	12" (300mm)	12" (300mm)
Qty./Bundle	Includes: 12 Optimizer Panels (6 pairs per bundle)				
Code #		NUS-100PT-06	NUS-100PT-08	NUS-100PT-10	NUS-100PT-12
Web Qty. Red'd/Bundle		36	36	36	36

- Units come unassembled.
- Insert webs required per bundle - refer to web order chart on left.

Visit the Resource Center on Nudura's website ([nudura.com/resource-center](http://nudura.com/resource-center)) for design details, BIM library, installation links & more.

Refer to pages 28-33 for all related product accessories & tools. For additional information visit [nudura.com](http://nudura.com) or call 866-468-6299.

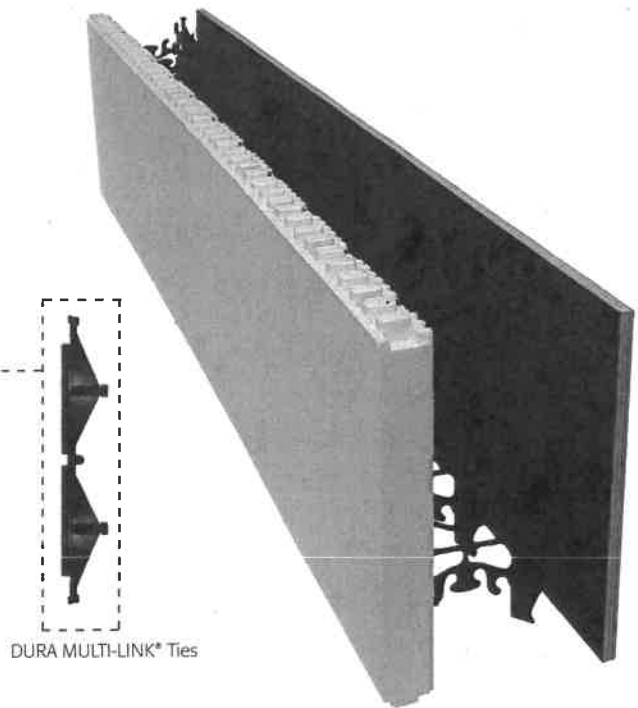

DURA MULTI-LINK® Ties



Metal Jig for One Series assembly

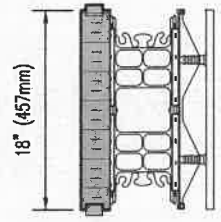
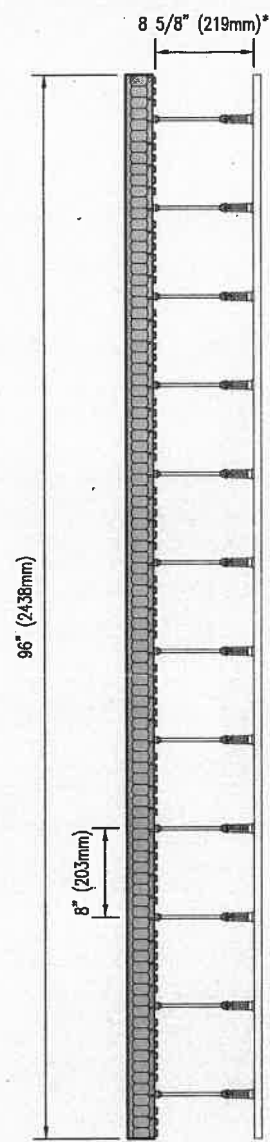

\*Dimension varies with insert web width

**90° Corner Panel Options**

**90° Corner EPS Panel Outside**

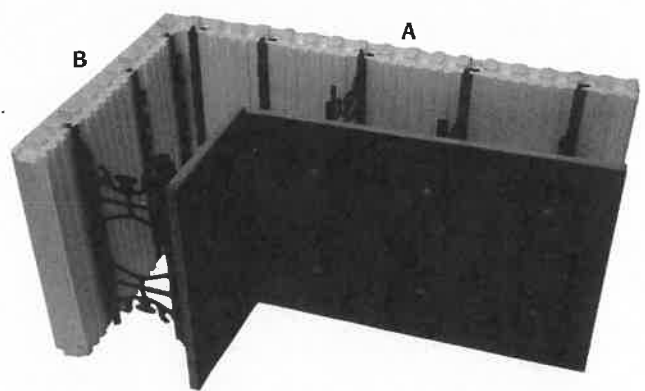

**90° Corner EPS Panel Inside**

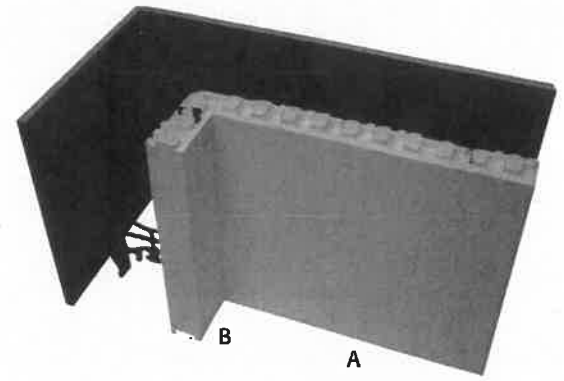

Note: Corner designation refers to EPS panel location.

Refer to pages 28-33 for all related product accessories & tools. For additional information visit nudura.com or call 866-468-6299. See next page for more information and codes to order the One Series.

Visit the Resource Center on Nudura's website ([nudura.com/resource-center](http://nudura.com/resource-center)) for design details, BIM library, installation links & more.

**NOTE:**

To assemble a **SINGLE One Series Form Unit** you will require the following components:

**STANDARD**

- 1 x Standard EPS Panel
- 1 x Plywood Panel
- 24 x Screws
- 12 x DURA MULTI-LINK® Ties
- 12 x Insert Webs
- 1 x Jig

**90° CORNER OUTSIDE**

- 1 x 90° **Outside** EPS Panel
- 1 x Plywood Panel
- 8 x Screws
- 4 x DURA MULTI-LINK® Ties
- 4 x Insert Webs
- 1 x Jig

**90° CORNER INSIDE**

- 1 x 90° **Inside** EPS Panel
- 1 x Plywood Panel
- 12 x Screws
- 6 x DURA MULTI-LINK® Ties
- 4 x Insert Webs
- 1 x Jig

	Plywood*	Standard	90° Outside	90° Inside
<b>Length A</b>	96" (2438mm)	96" (2438mm)	37 5/8" (956mm)	20 3/8" (518mm)
<b>Length B</b>	-	-	21 5/8" (549mm)	4 3/8" (111mm)
<b>Height</b>	18" (457mm)	18" (457mm)	18" (457mm)	18" (457mm)
<b>Qty./Bundle</b>	1 Plywood Panel	6 Standard Panels	4 Panels	16 Panels
<b>Code #</b>	NUS-APLYN-00	NUS-IOPAN-00	NUS-E0E90-00	NUS-I0STW-00
<b>Web Qty Req./Bundle</b>	-	72	16	64

Unassembled 45° Inside and Outside Panels available through special order only

\* Plywood panels must be cut on-site.

**Required Components**

**Hex Head Screw with Steel Flat Washer**

Size: #10 x 2.0" (50mm)

Qty./Pail: 1000

Code # : NUS-ASHEX-20

(2" (50mm) screws must be used – NUS-ASHEX-20)

**DURA MULTI-LINK® Ties**

Qty./Box: 96 pieces

Code # : NUS-EMULT-00

**Jig**

Metal Jig for One-Series Form assembly

Qty: 1 Jig

Code # : NUS-AONEJ-00

**Insert Webs (Ordered Separately)**

**Small Box**

Core Width	4" (100mm)	6" (150mm)	8" (200mm)	10" (250mm)	12" (300mm)
Qty./Box	100	100	100	100	100
Code #	NUS-IWEBS-04	NUS-IWEBS-06	NUS-IWEBS-08	NUS-IWEBS-10	NUS-IWEBS-12

**Large Box**

Core Width	4" (100mm)	6" (150mm)	8" (200mm)	10" (250mm)	12" (300mm)
Qty./Box	957	655	465	388	295
Code #	NUS-IWEBL-04	NUS-IWEBL-06	NUS-IWEBL-08	NUS-IWEBL-10	NUS-IWEBL-12

**Corner Connector**

The corner connector is designed to securely connect two panels of plypan together at a 90° corner.

Length: 10' (3m)

Code # : NUS-AONEC-00



Full length of connector not shown.

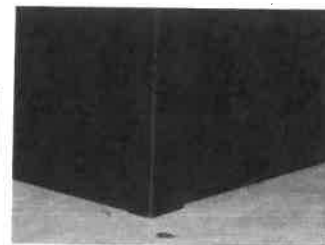

**Formply Inserts**



Fompoly inserts are a component of the Plypan Panels and can now be purchased separately.

Qty./Box: 2,400 pieces allowing production of 100 plypan panels

Code # : NUS-APLIN-00



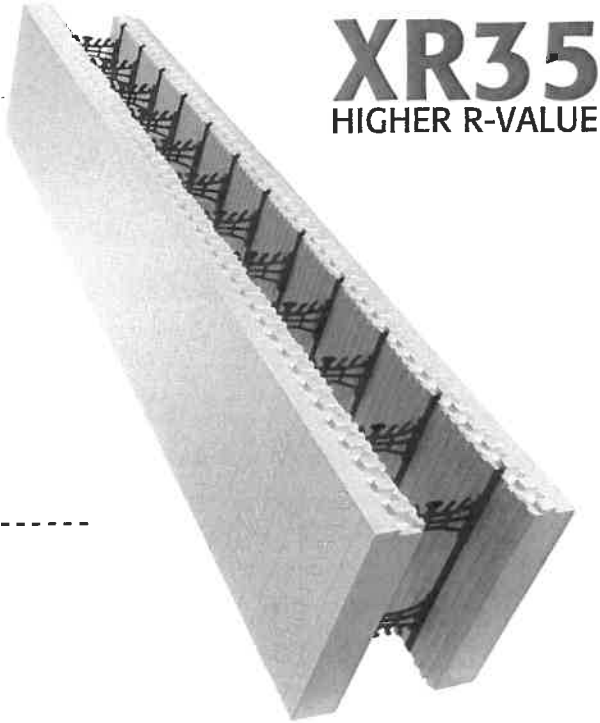

# XR35

HIGHER R-VALUE

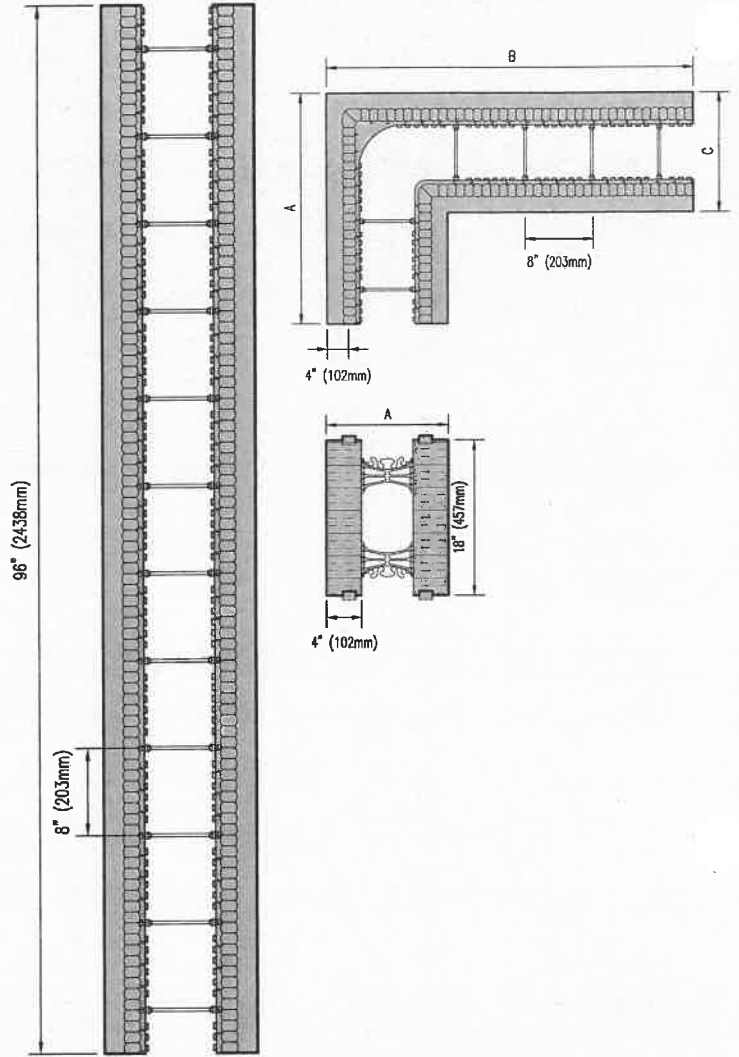
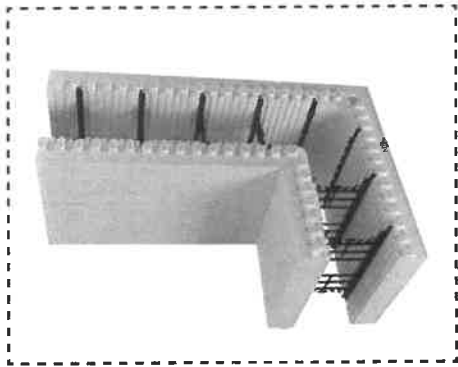

Webs are 5/8" away from the outside surface

## MAY WE SUGGEST: Heavy Duty Tape

### 4" Heavy Duty Tape

Used for covering the interlock at the top of a wall to protect it from concrete getting into the interlock.



Qty./Box	24 PCS
Code #	NUS-ATPHD-04
Dimensions	4" x 72 Yd (96mm x 66m)

Visit the Resource Center on Nudura's website ([nudura.com/resource-center](http://nudura.com/resource-center)) for design details, BIM library, installation links & more.

Refer to pages 28-33 for all related product accessories & tools. For additional information visit [nudura.com](http://nudura.com) or call 866-468-6299.

XR35 Standard Form		
Core Width	6" (150mm)	8" (200mm)
Length	96" (2438mm)	96" (2438mm)
Width A	14" (356mm)	16" (406mm)
Height	18" (457mm)	18" (457mm)
EPS Thickness	4" (102mm)	4" (102mm)
Qty./Bundle	2	2
Code #	NUS-IX496-06	NUS-IX496-08

XR35 Unassembled Panel	
Length	96" (2438mm)
Height	18" (457mm)
EPS Thickness	4" (102mm)
Qty./Bundle	4 Panels (2 pairs per bundle)
Code #	NUS-IXPAN-00

XR35 90° Corner Form		
Core Width	6" (150mm)	8" (200mm)
Length A	27" (686mm)	29" (737mm)
Length B	43" (1092mm)	45" (1143mm)
Length C	14" (356mm)	16" (406mm)
Height	18" (457mm)	18" (457mm)
Qty./Bundle	4	4
Code #	NUS-IX490-06	NUS-IX490-08

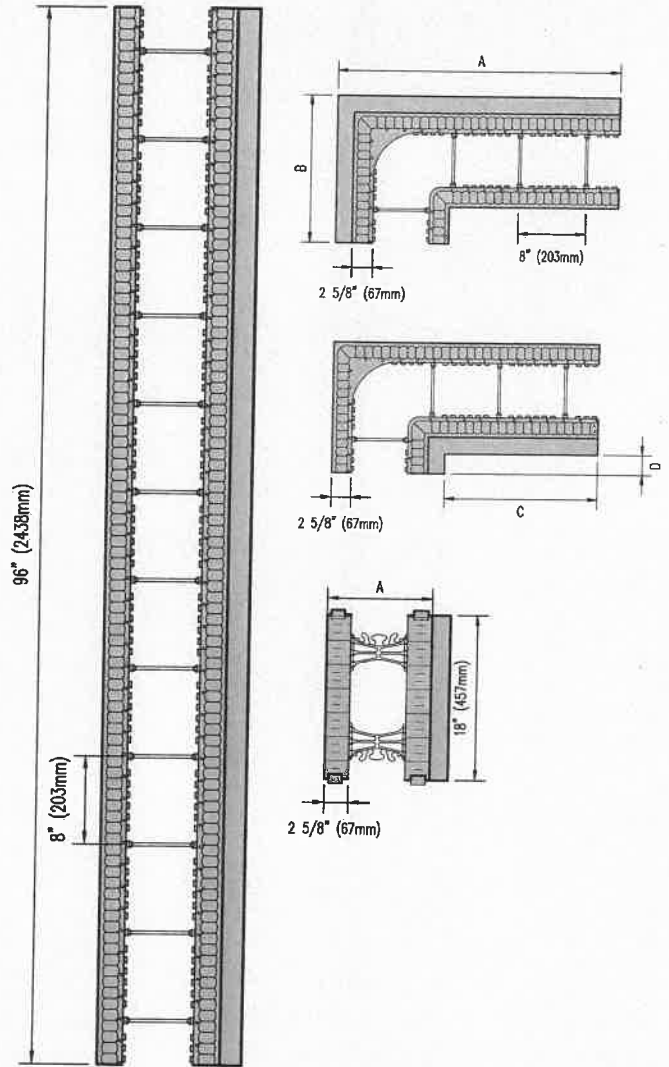
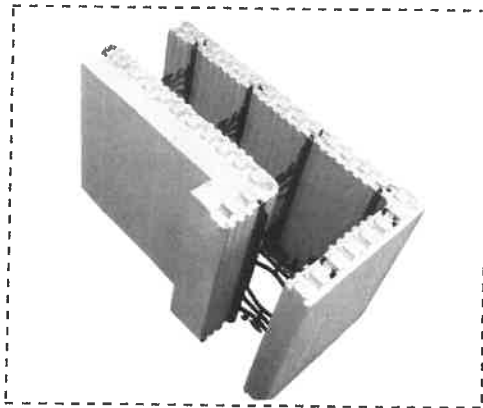
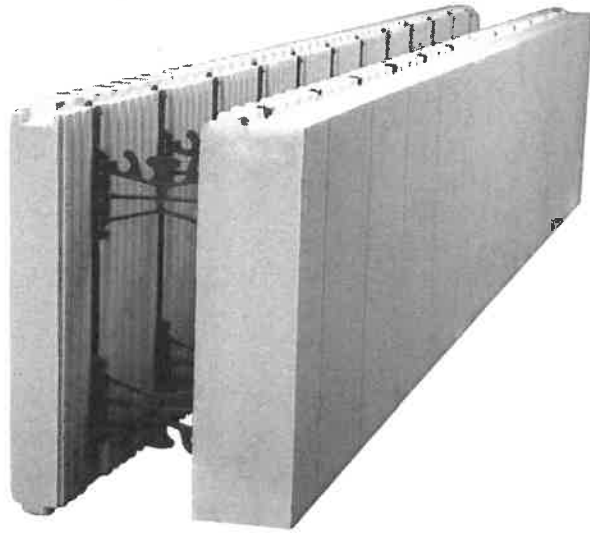

Information in the charts and the images show the 6" (150mm) form only

Standard Form Unit (Type 2 EPS Laminate on one side)				
Thickness	1" (25mm)	2" (50mm)	4" (100mm)	6" (150mm)
Length	96" (2438mm)	96" (2438mm)	96" (2438mm)	96" (2438mm)
Height	18" (457mm)	18" (457mm)	18" (457mm)	18" (457mm)
Qty./Bundle	3	3	3	3
Code #	NUS-P1096-06	NUS-P2096-06	NUS-P4096-06	NUS-P6096-06

\*Other form units & core thicknesses available through special request.  
\*Charts and images show 6" (150mm) form only.



1" (25mm)  
R-value - 28  
U-value - 0.21



2" (50mm)  
R-value - 32  
U-value - 0.18



4" (100mm)  
R-value - 40  
U-value - 0.15



6" (150mm)  
R-value - 48  
U-value - 0.12

Webs are 1 5/8" (41mm), 2 5/8" (67mm), 4 5/8" (117mm) and 6 5/8" (168mm) away from the outside when we laminate EPS to one side.

90° Form Unit - Outside (Long Side) (Type 2 EPS Laminate on one side)				
Thickness	1" (25mm)	2" (50mm)	4" (100mm)	6" (150mm)
Length A	32 5/8" (813mm)	33 5/8" (854mm)	35 5/8" (905mm)	37 5/8" (956mm)
Length B	16 5/8" (422mm)	17 5/8" (448mm)	19 5/8" (498mm)	21 5/8" (550mm)
Height	18" (457mm)	18" (457mm)	18" (457mm)	8" (457mm)
Qty./Bundle	6	6	6	6
Code #	NUS-P1L90-06	NUS-P2L90-06	NUS-P4L90-06	NUS-P6L90-06

90° Form Unit - Inside (Short Side) (Type 2 EPS Laminate on one side)				
Thickness	1" (25mm)	2" (50mm)	4" (100mm)	6" (150mm)
Length C	19 3/8" (492mm)	18 3/8" (467mm)	16 3/8" (416mm)	14 3/8" (365mm)
Length D	3 3/8" (86mm)	2 3/8" (60mm)	3/8" (10mm)	**
Height	18" (457mm)	18" (457mm)	18" (457mm)	18" (457mm)
Qty./Bundle	6	6	6	6
Code #	NUS-P1S90-06	NUS-P2S90-06	NUS-P4S90-06	NUS-P6S90-06

\*\*On-site notching of EPS foam required.

Refer to pages 28-33 for all related product accessories & tools.  
For additional information visit nudura.com or call 866-468-6299.

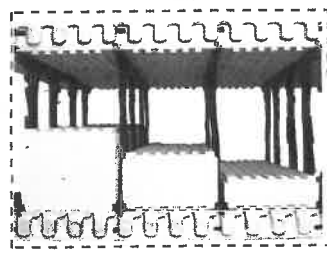
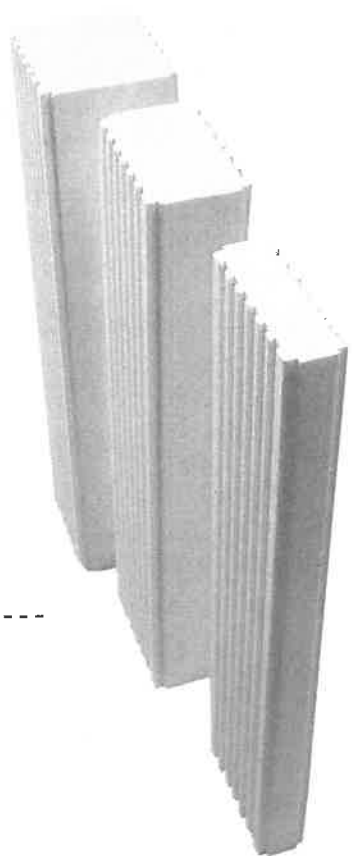

**Build your own R-Value**

The Nudura R-Value Plus+ inserts allow the ability to customize the desired amount of insulation needed to meet the specific requirements of any project. The inserts are available in 4 standard sizes: 1" (25mm), 2" (51mm), 4" (102mm) and 6" (152mm) and all 32" (812mm) long. Custom combinations can be created to provide further insulation value if desired and are compatible with core sizes ranging from 6" (150mm) to 12" (300mm).



1" (25mm)  
R-value - 31  
RSI - 5.460  
U-value - 0.183



2" (50mm)  
R-value - 33  
RSI - 5.812  
U-value - 0.172



4" (100mm)  
R-value - 40  
RSI - 7.045  
U-value - 0.142



6" (150mm)  
R-value - 47  
RSI - 8.28  
U-value - 0.121

6" (150 mm) concrete core R-Value ratings based on exterior brick finish

NUDURA Plus Series R-Value Inserts (EPS Foam Billet)				
Thickness	1" (25mm)	2" (50mm)	4" (100mm)	6" (150mm)
Width	7 1/2" (190mm)	7 1/2" (190mm)	7 1/2" (190mm)	7 1/2" (190mm)
Height	32" (812mm)	32" (812mm)	32" (812mm)	32" (812mm)
Qty/Bdle	85	48	24	24
Code #	NUS-PIN32-01	NUS-PIN32-02	NUS-PIN32-04	NUS-PIN32-06

Refer to pages 28-33 for all related product accessories & tools. For additional information visit nudura.com or call 866-468-6299.

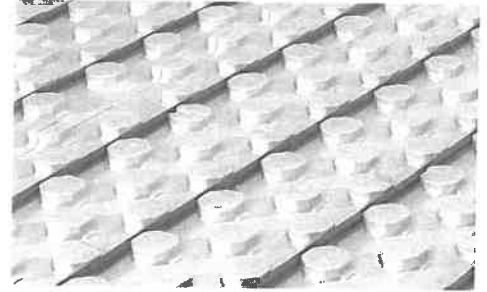

## The easy insulation for radiant heat.

HYDROFOAM® is the ideal radiant floor insulation product for residential and commercial construction projects that increases comfort and energy efficiency. HYDROFOAM maximizes radiant floor heating by ensuring the heat is dispersed evenly throughout the entire floor area, providing building occupants with a comfortable living and working environment. HYDROFOAM offers installers a lightweight high density expanded polystyrene (EPS) product that increases installation speeds, is easily cut to meet any angle or radius while providing up to R-16 (RSI 2.82, U-value 0.35) insulation value.

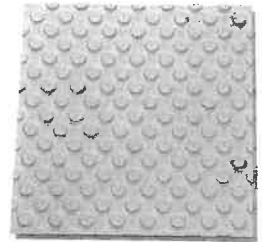

Installation is fast and easy compared to traditional foam insulation. The 4' x 4' (1219mm x 1219mm) boards, available in three thickness, are easily installed with an overlapping interlock on all four sides, ensuring the boards are locked in place during installation. HYDROFOAM® utilizes a 360° multidirectional friction fit anchor system that eliminates the need to tie the pex tubing to the wire mesh. Radiant heat piping is easily stepped into place in any direction required.

### Product Highlights:

- Insulation under the concrete slabs
- 4' x 4' (1.2m x 1.2m) molded boards
- Only 4" (100mm) from base to nubs
- Available thicknesses: R-10 (RSI 1.76, U-value 0.57), 3" (76mm) - R-12.6 (RSI 2.22, U-value 0.45), 4" (100mm) - R-16 (RSI 2.82, U-value 0.35)
- Multi-directional anchoring
- Compatible with 1/2" (13mm) and 5/8" (16mm) diameter radiant tubing
- Radiant tube spacing is based on 3" (76mm) increments
- Shiplap/interlocking on all 4 sides
- Eco-friendly - No CFCs or HCFCs
- 100% recyclable
- Resistant to water and moisture
- Qualifies as low emitting materials\*\*

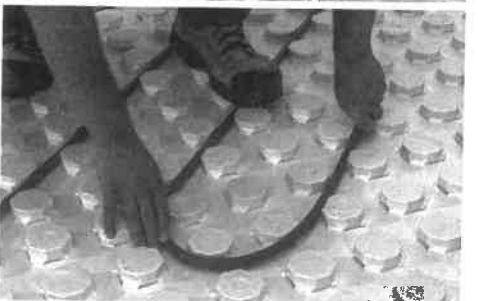
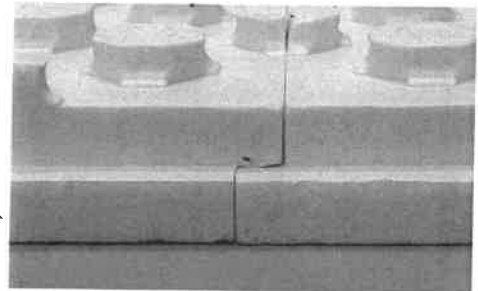

Sheet Thickness	2 1/2" (64mm)	3" (76mm)*	4" (100mm)
Sheet Size	48" x 48" (1219 x 1219mm)	48" x 48" (1219 x 1219mm)	48" x 48" (1219 x 1219mm)
Qty./Bundle	10	8	6
Code #	NUS-FORHF-25	NUS-FORHF-30	NUS-FORHF-40

\* 3" (76mm) thick HYDROFOAM is only available from the Coaldale, AB plant, special order.

\*\* Conforms to LEED 4.1 CPDH testing standards

For more information download our Technical Data Sheet on [nudura.com](http://nudura.com)





## Foundation Wall Insulation

HOMEGA® is a 4' x 8' (1219mm x 2438mm) individually molded insulation panel with three integrated furring strips at 16" (406mm) apart centre and shiplapped on all 4 sides. It is a unique, patented, 2-in-1 system offering superior performance. It can be used to insulate foundation walls and floors, interior and exterior walls and ceilings. The panel comes in thicknesses of 2 5/8" (67mm), 3 1/2" (89mm) and 3 7/8" (98mm), allowing you to reach an R value of R-10 (RSI 1.76, U-value 0.57) to R-15 (RSI 2.64, U-value 0.38)



For basement insulation, install the boards using mechanical anchors. In places where the panels overlap and need to be cut; seal the space with Nudura low-expansion spray foam. Install drywall directly to the insulation board's furring strips. For floor insulation, glue the panel with a solvent-free glue to prevent movement (optional). Cross the plywood joints with HOMEGA insulation board's joints and screw at 12" (305mm) intervals over the length of the furring strips. Finally, apply the selected finishing material.

### Economical

- Quick and easy installation
- Permanent insulation value
- 2-in-1 product: insulates concrete slab and supports pipes
- Energy Savings: reduced heating bills

### Sustainable

- 100% recyclable
- No CFCs or HCFCs
- Inorganic and rot-proof materials
- Resistant to water and moisture that can cause mildew
- Qualifies as low emitting materials\*\*

### Insulation Advantages

- Molded panel: superior physical properties
- Flexibility to cut any shape or size
- Better deal: shiplapped on all sides
- Increased comfort as a result of uniform temperature
- Interlocking air tight design
- Available with wood or plastic furring strips

Sheet Thickness	2 5/8" (67mm)	3 1/2" (89mm)	3 7/8" (98mm)
Sheet Size	48" x 96" (1219 x 2438mm)	48" x 96" (1219 x 2438mm)	48" x 96" (1219 x 2438mm)
Qty./Bundle	6	4	4
Strapping*	Wood   Polystyrene	Wood   Polystyrene	Wood   Polystyrene
Code #	NUS-FCW25-81   NUS-FCP25-81	NUS-FCW31-21   NUS-FCP31-21	NUS-FCW37-81   NUS-FCP37-81

\*Polystyrene strapping only to be used in retrofit applications \*\* Conforms to LEED 4.1 CPDH testing standards

#10 Wood Screw			
#10 Screws	4" (102mm)	5" (127mm)	6" (152mm)
Qty./Box	500	500	500
Code #	NUS-ASCRW-40	NUS-ASCRW-50	NUS-ASCRW-60

1/4" Concrete Screws			
Concrete Screws	5" (127mm)	5" (127mm)	6" (152mm)
Qty./Pail	50	300	50
Code #	NUS-ASCCS-50	NUS-ASCCS-50	NUS-ASCCS-60

For more information download our Technical Data Sheet on [nudura.com](http://nudura.com)  
Conforms to LEED 4.1 CPDH testing standards



# Nudura Form Accessories

## Brick Ledge Extension & 6" (152mm) Screw & Plastic Washer

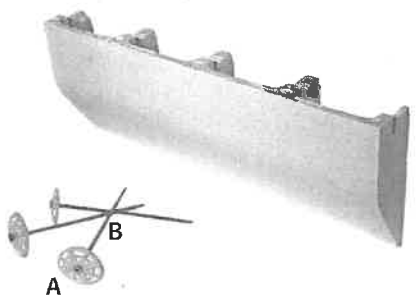

Length	32" (813mm)
Width	4 1/2" (114mm)
Height	13" (330mm)
Qty./Bundle	14
Code #	NUS-ABLEX-00

Brick Ledge Extensions are used for supporting standard brick or stone veneer finishes, when constructing brick ledges at corners, and can be installed to meet any elevation change or slope.



A. Plastic Washer

Qty./Box	250
Code #	NUS-ASCPW-00

B. 6" (152mm) Screw

Qty./Box	500
Code #	NUS-ASCRW-60

Screw & Plastic Washer to be used to attach the Brick Ledge Extension to the form wall or to attach additional foam panels for increased insulation to a building.

## End Cap

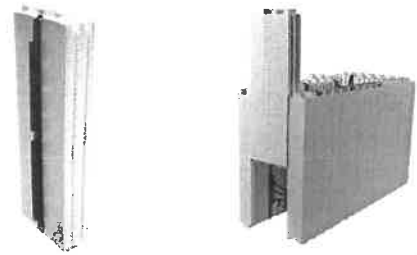

Width	4" (100mm)	6" (150mm)	8" (200mm)	10" (250mm)	12" (300mm)
Height	18" (457mm)	18" (457mm)	18" (457mm)	18" (457mm)	18" (457mm)
EPS Thickness	2 5/8" (67mm)	2 5/8" (67mm)	2 5/8" (67mm)	2 5/8" (67mm)	2 5/8" (67mm)
Qty./Box	57	40	30	35	30
Code #	NUS-A0ECF-04	NUS-A0ECF-06	NUS-A0ECF-08	NUS-A0ECF-10	NUS-A0ECF-12

End Cap (with Fastening Strip) can be used to terminate a wall. It can also be used as a buck material for windows.

## Height Adjuster & Height Adjuster Tie



Length	32" (813mm)
Height	3" (76mm)
Qty./Bundle	80
Code #	NUS-AHDJF-00

The Height Adjuster (with Fastening Strip) combined with the Height Adjuster Tie can increase the height of a wall by 3" (75mm) increments. The Height Adjuster ties allow the foam panels to be connected together. Site assembly required.

Height Adjuster Tie One NUS-AHDJF-00 Bundle requires 160 Height Adjuster Ties

Core Width	4" (100mm)	6" (150mm)	8" (200mm)	10" (250mm)	12" (300mm)
Qty./Box	100	100	100	100	80
Code #	NUS-AHADT-04	NUS-AHADT-06	NUS-AHADT-08	NUS-AHADT-10	NUS-AHADT-12

## FORM-LOCK

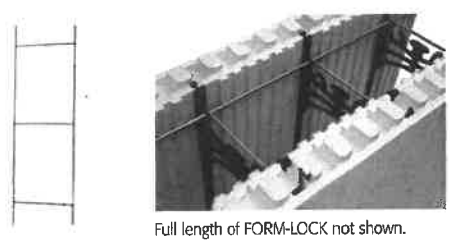

Available for 6" - 12" (150 - 300mm) Standard Forms only.

Core Width	6" (150mm)	8" (200mm)	10" (250mm)	12" (300mm)
Length	10' (3m)	10' (3m)	10' (3m)	10' (3m)
Qty./Bundle	10	10	10	10
Code #	NUS-ABLOK-06	NUS-ABLOK-08	NUS-ABLOK-10	NUS-ABLOK-12

FORM-LOCK is used to maintain wall straightness. Other uses include wall alignment for vertical stack joints. Each bundle has 100' (30m) of FORM-LOCK.

## Lintel Cavity Closure

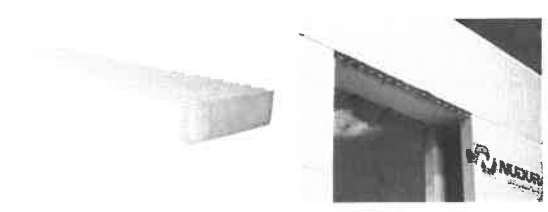

The Lintel Cavity Closure provides installers a product that provides insulation above and below the window to minimize thermal bridging. The Nudura Lintel Cavity Closure is available in a standard 2" (50mm) thickness.

Core Width	4" (100mm)	6" (150mm)	8" (200mm)	10" (250mm)	12" (300mm)
Qty./Box	84	60	48	36	36
Code #	NUS-PLINT-04	NUS-PLINT-06	NUS-PLINT-08	NUS-PLINT-10	NUS-PLINT-12

## 4-Way Web Connector

Qty./Box	100 PCS
Code #	NUS-A4XWC-00

The 4-Way Web Connector allows two or more insert webs to be connected together and used with the panel system to create wider form sizes. It also can be used to create forms of different shapes and sizes. Increased design flexibility.

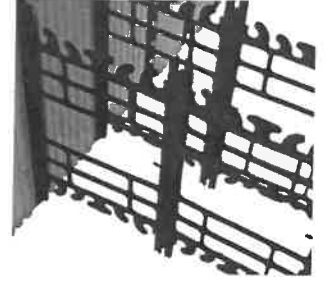

## ICF Hanger System (Formerly; Multi Purpose Anchor Hanger System)

The ICF Hanger System is available in both standard Flat and 45-degree angle plates. In conjunction with Stamped Bearing Bracket the Hanger System provides a solid wood floor or wood roof connection to the Nudura wall. An inexpensive yet labor-friendly connection system.

Retrofit Brackets are also available and used when a change occurs after the concrete has been placed into the forms and cures.

**A. ICF Hanger Insert Plate**      **D. Stamped Bearing Bracket**  
(\*12 Screws Incl. - Box of 170)

Qty./Box	50 PCS	Qty./Box	25 PCS
Code #	NUS-AIHIP-00	Code #	NUS-AISBB-00

### B. 45° ICF Hanger Insert Plate

Qty./Box	20 PCS	1/4" x 4" Hex Lag Screws Incl. - Box of 60
Code #	NUS-AIHIP-45	

### C. Retrofit Bracket

Qty./Box	12 PCS	Lag Bolts not included.
Code #	NUS-AIRFB-00	

## Transition Bracket

Qty./Box	100 PCS
Code #	NUS-ATRBR-00

The Transition Bracket allows two different form widths to be connected together. Primary use is to create a ledge to support brick or a floor system.



## Rebar Clip

Qty./Box	200 PCS
Code #	NUS-ARCLP-00

The Rebar Clip is designed to support horizontal rebar in the bottom web of the Nudura form, eliminating the need to tie wire or zip-tie the bar in place.

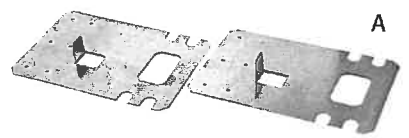



## Vertical Joint Clip

Qty./Box	200 PCS
Code #	NUS-A0VJC-00

The Vertical Joint Clip is designed to connect the forms together at the vertical joints. It replaces having to tie wire or tape forms together while providing a solid connection using minimal amount of labor to install.

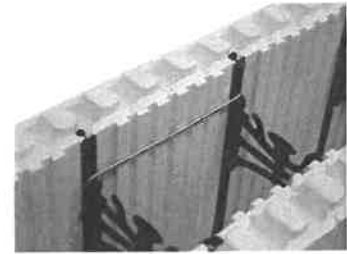

## Hex Head Screw with Steel Flat Washer

Size	#10 x 2" (50mm)	#10 x 2.5" (64mm)	#10 x 3" (76mm)
Qty./Box	1000 PCS	1000 PCS	1000 PCS
Code #	NUS-ASHEX-20	NUS-ASHEX-25	NUS-ASHEX-30

The #10 screw can be used to connect the Nudura Alignment System to the forms. Other uses include attachment of strapping or buck material to concrete. Available in 2" (50mm), 2 1/2" (64mm), and 3" (76mm) lengths. Two 1/4" (6mm) nut drivers included per pail.

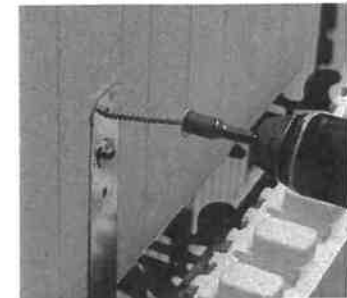

Product may be different than shown. Product subject to change.

## 10 Piece Bit Kit

Contact your local distributor for more information on how to order.

Qty./Box	12 KITS
Code #	NUS-ABITK-00

Ten piece kits include five 1/4" magnetic nutsetters which can be used with any of Nudura's Hex Head Screws with Steel Flat Washers, as well as five #2 red square driver bits. The durable plastic case keeps all the bits together in one convenient spot and limits trying to find drivers bits on site during construction.



## V-Clip

Qty./Box	250 PCS
Code #	NUS-AVCLP-00

The V-Clip is used to connect a Nudura panel to a concrete floor. It allows the contractor to support the panel without additional materials used on the outside of the wall.



## Easy Buck

Qty./Box	10 PCS
Code #	NUS-AWBCK-00
Dimensions	10' (3m) Long

The Easy Buck is used for window and door jambs and allows nominal sized lumber to fit between the Expanded Polystyrene (EPS) panels. Primary uses are for doors and windows. Each bundle contains 100' (30m) of Easy Buck.

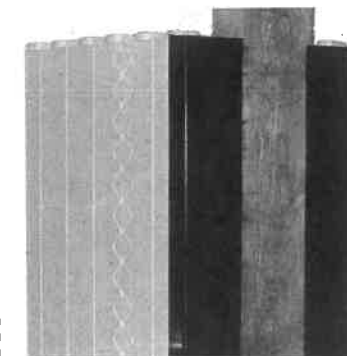



### Brick Ties Cast-In Place (Galvanized Steel)

Qty. /Box	100 PCS
Code #	NUS-ABRKG-00

### Brick Ties Cast-In Place (Stainless Steel)

Qty./Box	100 PCS
Code #	NUS-ABRKS-00

Cast-In Place Brick Tie and Pintle. – Enables solid anchorage of veneer masonry through exterior foam to concrete core; tested to meet ASTM D754 (USA) and CSA-A370 (CAN) std. requirements for masonry anchors.

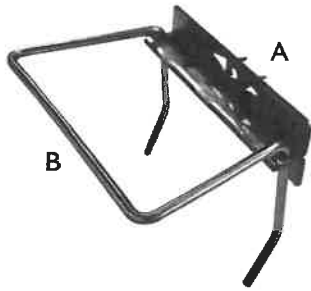

### Surface Mount Brick Ties (A)

Qty. /Box	100 PCS
Code #	NUS-ASBRK-00

### Pintle (B)

Qty. /Box	100 PCS
Code #	NUS-APNTL-00

Surface Mount Brick Tie and Pintle. – Designed to be fastened with two Nudura Hex head Screws anywhere on the Nudura fastening strip. This tie will accept Nudura Pintels and other smaller dimension pintels. tested to meet ASTM D754 (USA) and CSA-A370 (CAN) std. requirements for masonry anchors.

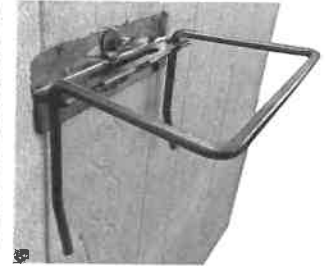

### Fiber Tape

Qty./Box	18 PCS
Code #	NUS-ATPCL-04
Dimensions	1" x 60 Yd (24mm x 55m)

Fiber Tape is used to provide additional EPS support for field cut forms that have more than 4" (100mm) of EPS extending past the last web, brick ledge forms in corner conditions, and radius panels.

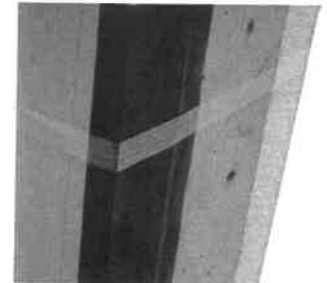

### 4" Protective Tape

Qty./Box	36 PCS
Code #	NUS-ATAPE-01
Dimensions	4" x 72 Yd (96mm x 66m)

The 4" (100mm) Protective Tape is used for covering the interlock at the top of a wall to prevent concrete from flowing into the interlock.

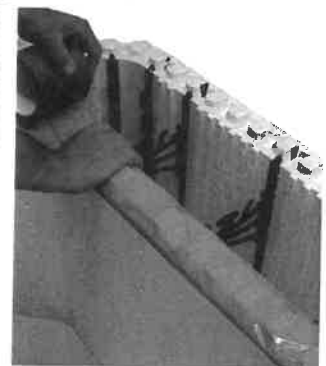

### 4" Heavy Duty Tape

Qty./Box	24 PCS
Code #	NUS-ATPHD-04
Dimensions	4" x 72 Yd (96mm x 66m)

The 4" (100mm) Heavy Duty Tape is used for covering the interlock at the top of a wall to prevent concrete from flowing into the interlock.





## NUBASE Parging Mix - Coverage of 75 sq. ft. (7m<sup>2</sup>)

Qty.	1 BAG
Code #	NUS-APARG-00

The NUBASE parge mix is a dry cementitious product that is used to cover exposed EPS that is not covered by an exterior finish. Used in conjunction with Fiber Mesh.



## Fiber Mesh - Coverage of 475 sq. ft. (44m<sup>2</sup>)

Qty.	1 ROLL
Code #	NUS-AMESH-00

The fiber mesh gets embedded into the parge coat to give it strength.

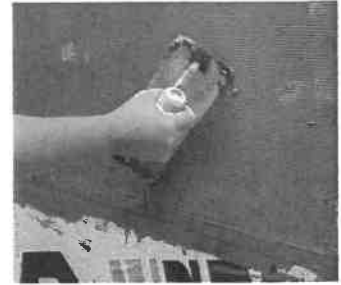

## NUDURA Low Expansion Foam - 24oz (680g)

Qty./Box	12 PCS
Code #	NUS-AFOAM-00

The Low Expansion Foam is compatible with Nudura's Expanded Polystyrene (EPS) foam and can be used for a number of different tasks on site including foaming the forms to the slab or footing, between vertical joints, securing service penetrations, and as insulation around openings.

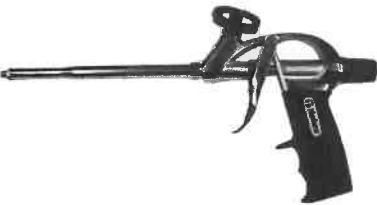
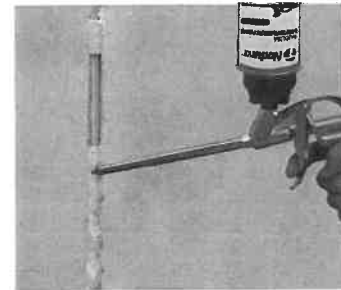

## Foam Gun (Metal Handle)

Qty.	1 GUN
Code #	NUS-AGUNM-00

The metal handle Foam Gun is compatible with the Nudura Low Expansion Foam 24oz (680g) cans. The Nudura Low Expansion Foam can be used for a number of different tasks on site.



## Foam Gun Cleaner - 21oz (340g)

Qty./Box	12 PCS
Code #	NUS-AFOCL-00

The Foam Gun Cleaner is used to clean the internal chamber of the foam gun from any hardened foam. Also used on the external surfaces for cleaning the guns.



## T-Form Support Strap

Qty./Bundle	30 PCS
Code #	NUS-ATSTP-00

Created to aid in installation and support on-site cut T-connections. The steel straps are designed to hook over the internal reinforcing on the main wall of a T-Wall connection and be secured to the fastening strips of the "T" portion of the wall.

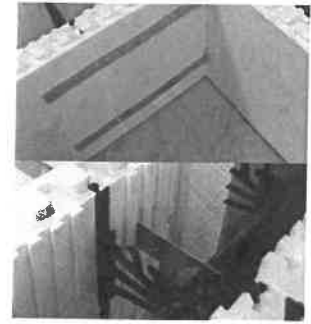

## Folding Saw

Qty.	1 SAW / 12 Per Box
Code #	NUS-AFSAW-00

A great combination of cutting power and comfort, whether you're cutting overhand or making undercuts in the form. The soft grip handle provides a secure grip and the saw folds and locks for space-saving storage and safe transportation.

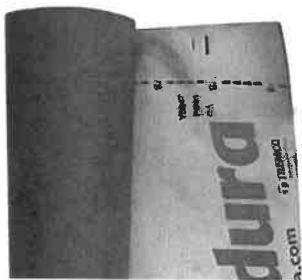

## Waterproofing Membrane - 225 sq. ft. (21m<sup>2</sup>)

A. Summer Grade		B. Winter Grade	
Qty.	1 ROLL	Qty.	1 ROLL
Code #	NUS-AWPRF-00	Code #	NUS-AWPRF-02

The Peel & Stick Waterproofing Membrane is used for below grade dampproofing of the Nudura walls. Other uses for the Waterproofing Membrane include drain flashings around window and door openings and brick ledge through wall flashings. Available in summer and winter grades.



## Membrane Primer

Qty.	1 PAIL
Code #	NUS-AWPRM-00

The Membrane Primer is designed for use with Nudura's peel and stick waterproof membranes. This polymer emulsion-based primer is available in a 19L (5 gallon) pail, with a coverage of approximately 1020 sq. ft. (95m<sup>2</sup>) of wall area per pail. The membrane primer can help improve adhesion of Nudura's Waterproofing Membrane in specific areas.



## Rebar Bender Cutter

Qty.	1 Bender/Cutter
Code #	NUS-AREBC-00

The Rebar Bender Cutter is used for cutting and bending reinforcing steel used in the Nudura wall system. Comes with two cutting heads which will cut up to #5 (15M) reinforcing steel. The rollers used for bending the steel are capable of handling up to a #5 (15M) bar.

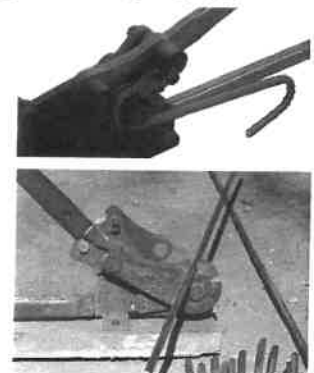

# Nudura Alignment System

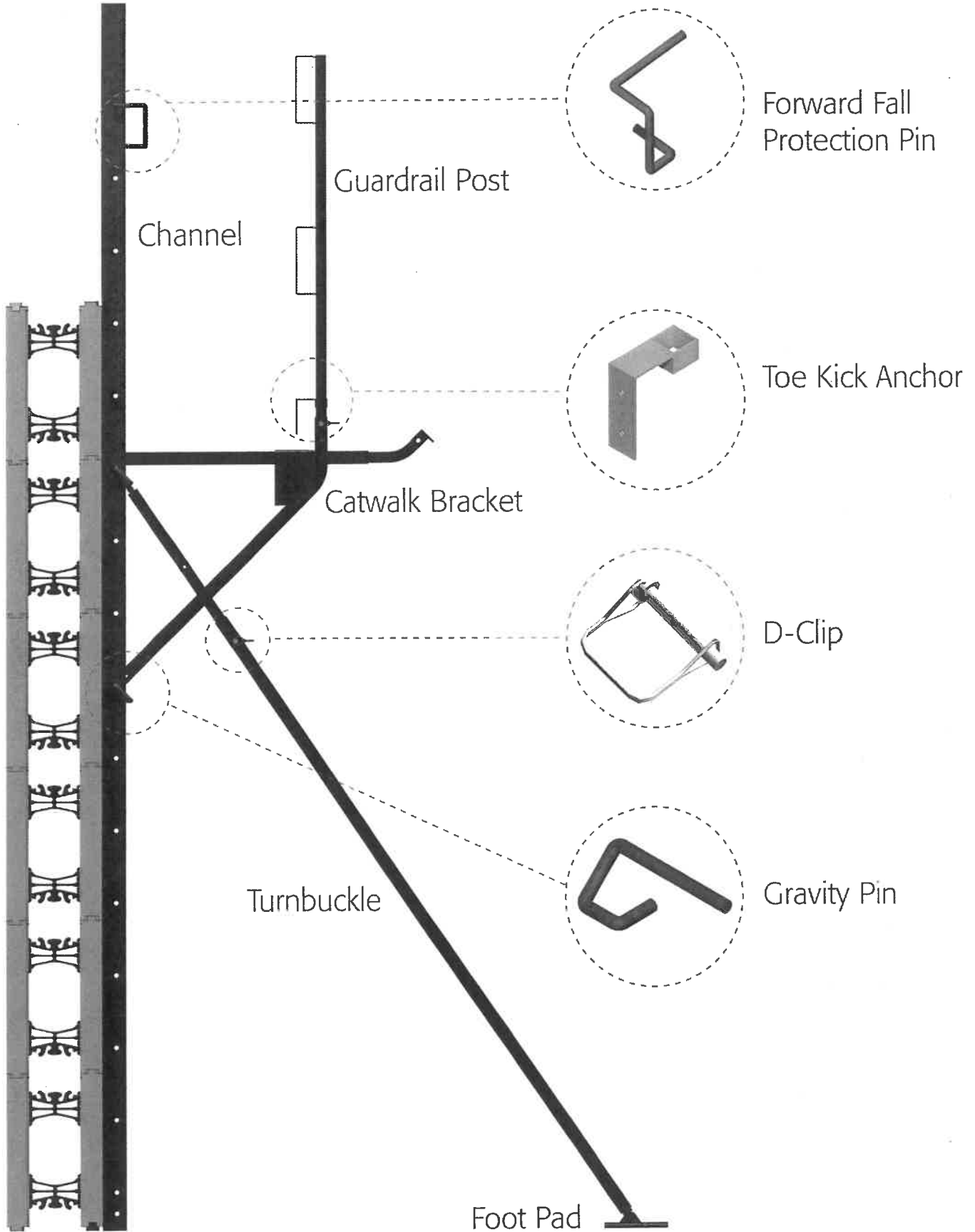

Diagram above illustrates both Square & Round Tube Bracing. For reference only.

# Nudura Alignment System

## Square Tube Bracing - No Wall Channels

<b>Includes</b>	20 Guardrail Post 20 Catwalk Brackets 20 Turnbuckles 40 Gravity Pins
-----------------	---

<b>Code #</b>	NUS-BRACN-00
---------------	--------------

Packaged on a wooden skid.

↔Metal Bracing Rack available to order separately.

Wall Channels ordered separately. See right.

## Wall Channels (Bracing Not Included)

8' (2m)	NUS-BSCHA-08*
10' (3m)	NUS-BSCHA-10
12' (4m)	NUS-BSCHA-12

<b>Channels/Bdl</b>	20
---------------------	----

## Square Tube Bracing w/10' Wall Channels

<b>Includes</b>	20 - 10' Wall Channels 20 Guardrail Post 20 Catwalk Brackets 20 Turnbuckles 40 Gravity Pins
-----------------	---

<b>Code #</b>	NUS-BSTRN-10**
---------------	----------------

↔Packaged in Metal Bracing Rack

## Square Tube Bracing w/12' Wall Channels

<b>Includes</b>	20 - 12' Wall Channels 20 Guardrail Post 20 Catwalk Brackets 20 Turnbuckles 40 Gravity Pins
-----------------	---

<b>Code #</b>	NUS-BSTRN-12*
---------------	---------------

↔Packaged in Metal Bracing Rack

## Round Tube Bracing w/10' Wall Channels

<b>Includes</b>	20 - 10' Wall Channels 20 Guardrail Post 20 Catwalk Brackets 20 Turnbuckles 40 Gravity Pins
-----------------	---

<b>Code #</b>	NUS-BRTRN-10*
---------------	---------------

↔Packaged in Metal Bracing Rack

## Round Tube Bracing w/12' Wall Channels

<b>Includes</b>	20 - 12' Wall Channels 20 Guardrail Post 20 Catwalk Brackets 20 Turnbuckles 40 Gravity Pins
-----------------	---

<b>Code #</b>	NUS-BRTRN-12*
---------------	---------------

↔Packaged in Metal Bracing Rack

## D Clip

<b>Includes</b>	100/Box
<b>Code #</b>	NUS-BDCLP-00

## Gravity Pins - 6" (152mm)

<b>Includes</b>	50/Box
<b>Code #</b>	NUS-BSGPN-00

## Forward Fall Protection Pin

<b>Includes</b>	40/Box
<b>Code #</b>	NUS-BFFPN-00

## Toe Kick Anchor

<b>Includes</b>	40/Box
<b>Code #</b>	NUS-BSTTK-00

\*Special Order - production time required to fulfill order.

\*Also available assembled as a European version NUS-BSTRE-10



↔Metal Bracing Rack - Code # NUS-BRCKS-10

# Nudura Tall Wall Adapter

## Nudura Tall Wall Adapter Kit

Includes	20 Scaffold to Turnbuckle Adapters
	20 Channel to Scaffold Adapters
	20 Scaffold to Scaffold Adapters

Code # NUS-BTWKT-00\*

## Tall Wall Nut & Cross Tie Kit

Includes	50 Cross Ties
	100 Nuts

Code # NUS-BNTCR-00

## Tall Wall Connector Wires - 14" (356mm)

Includes	100 Connector Wires
----------	---------------------

Code # BTWCW-00

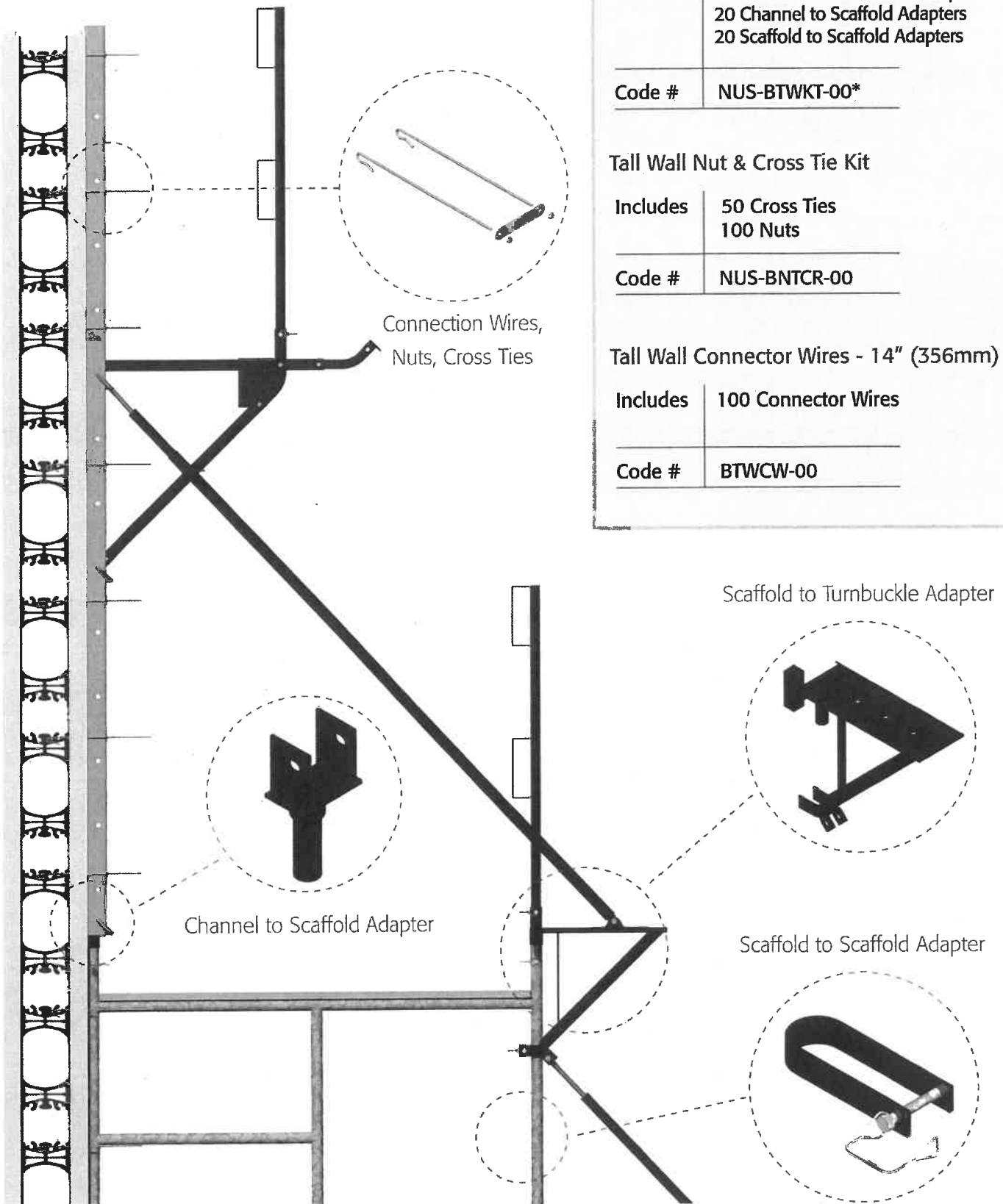

Diagram above illustrates Tall Wall Adapter Kit on Bracing. For reference only.

**\*Special Order** - production time required to fulfill order.  
**NOTE:** Tall Wall only compatible with square tube bracing.







visit nudura.com to find a distributor near you.



Over 50 years of building experience.

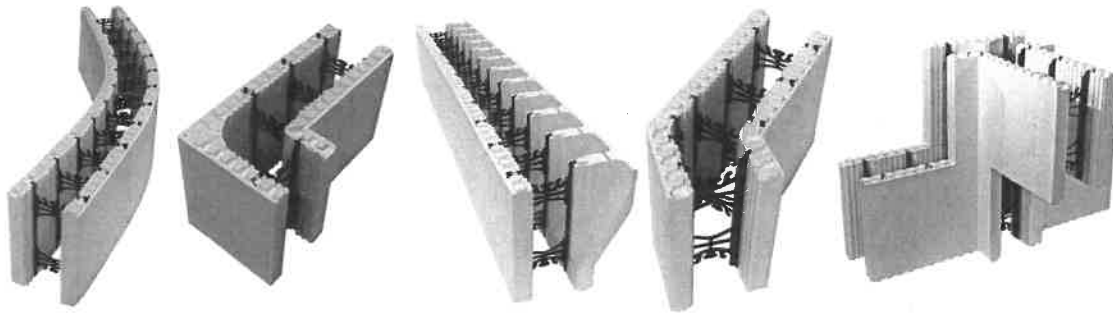

By using Nudura Insulated Concrete Forms to build your next structure you can ensure you are choosing the best building solution available today.

Scan to learn more about the innovation behind NUDURA ICFs



The information contained in this Nudura® Product Catalogue is presented only for the purpose of providing information on the various products composing the Nudura Integrated Building Technologies and any associated accessories (the "Nudura Products"). This Product Catalogue SHOULD NOT be used as a substitute for professional engineering consultation. Nudura makes no general warranties to the specific applicability of any of the products to any or all situations for which a designer may elect their use. Final amendment or modification to suit the exact circumstance of employment of any such products is the responsibility of the project designer. Nudura does not have any control over the installation or workmanship used in the assembly or installation of the Nudura Products. Nudura and its affiliated entities shall not be held liable for any general, special, direct, indirect or consequential damages, including bodily harm, which may be suffered by any person including, without limitation, an installer, contractor, subcontractor, architect, engineer, homeowner or building owner due to the use, assembly or installation of the Nudura Products. The Nudura Products are sold subject to the Nudura 30-Year Limited Warranty. Nudura®, N Design®, Integrated Building Technology®, Building Has Evolved®, DURALOK Technology®, DURAFOLD Technology®, DURAMAX Technology® and DURA MULTI-LINK® are trademarks of Nudura Inc.

All other trademarks cited herein are the property of their respective owners.

Follow us on:

[tremcocpg.com](http://tremcocpg.com)



*Construction Products Group*