



Department of Administration
 Purchasing Division
 2019 Washington Street East
 Post Office Box 50130
 Charleston, WV 25305-0130

State of West Virginia
 Centralized Request for Quote
 Construction

Proc Folder: 1278664		Reason for Modification:	
Doc Description: Hawks Nest State Park New Sewage Lift Station		Addendum #1 issued to publish project Q&A, pre-bid sign in, and extend bid due date until 10/5/2023.	
Proc Type: Central Purchase Order			
Date Issued	Solicitation Closes	Solicitation No	Version
2023-09-21	2023-10-05 13:30	CRFQ 0310 DNR2400000004	2

BID RECEIVING LOCATION

BID CLERK
 DEPARTMENT OF ADMINISTRATION
 PURCHASING DIVISION
 2019 WASHINGTON ST E
 CHARLESTON WV 25305
 US

10/05/23 10:37:55
 WV Purchasing Division

VENDOR

Vendor Customer Code:

Vendor Name : ALL Pumps Sales + Service, INC.

Address :

Street : 2182 Rt 75

City : ARNOVA

State : WV **Country :** U.S. **Zip :** 25530

Principal Contact : Tom Fellure

Vendor Contact Phone: 304-453-5610 **Extension:**

FOR INFORMATION CONTACT THE BUYER

Joseph E Hager III
 (304) 558-2306
 joseph.e.hageriii@wv.gov

Vendor Signature X *Thomas J. Fellure* **FEIN#** 46-0859517 **DATE** 10/4/23

All offers subject to all terms and conditions contained in this solicitation

ADDITIONAL INFORMATION

The West Virginia Purchasing Division is soliciting bids on behalf of the Division of Natural Resources to establish a contract for construction of replacement of the wastewater lift station at Hawks Nest State Park in Ansted, West Virginia per the attached specifications and terms and conditions.

INVOICE TO	SHIP TO
DIVISION OF NATURAL RESOURCES PARKS & RECREATION-PEM SECTION 324 4TH AVE SOUTH CHARLESTON WV US	DIVISION OF NATURAL RESOURCES HAWKS NEST STATE PARK 49 HAWKS NEST PARK RD ANSTED WV US

Line	Comm Ln Desc	Qty	Unit Issue	Unit Price	Total Price
1	Heavy construction services	①		<i>\$135,000.00</i>	<i>\$135,000.00</i>

Comm Code	Manufacturer	Specification	Model #
72121504			

Extended Description:
Hawks Nest State Park Sewage Lift Station

SCHEDULE OF EVENTS

<u>Line</u>	<u>Event</u>	<u>Event Date</u>
-------------	--------------	-------------------

	Document Phase	Document Description	Page
DNR2400000004	Final	Hawks Nest State Park New Sewage Lift Station	3

ADDITIONAL TERMS AND CONDITIONS

See attached document(s) for additional Terms and Conditions

ADDENDUM ACKNOWLEDGEMENT FORM
SOLICITATION NO.: CRFQ DNR24*04

Instructions: Please acknowledge receipt of all addenda issued with this solicitation by completing this addendum acknowledgment form. Check the box next to each addendum received and sign below. Failure to acknowledge addenda may result in bid disqualification.

Acknowledgment: I hereby acknowledge receipt of the following addenda and have made the necessary revisions to my proposal, plans and/or specification, etc.

Addendum Numbers Received:

(Check the box next to each addendum received)

- | | |
|--|--|
| <input checked="" type="checkbox"/> Addendum No. 1 | <input type="checkbox"/> Addendum No. 6 |
| <input type="checkbox"/> Addendum No. 2 | <input type="checkbox"/> Addendum No. 7 |
| <input type="checkbox"/> Addendum No. 3 | <input type="checkbox"/> Addendum No. 8 |
| <input type="checkbox"/> Addendum No. 4 | <input type="checkbox"/> Addendum No. 9 |
| <input type="checkbox"/> Addendum No. 5 | <input type="checkbox"/> Addendum No. 10 |

I understand that failure to confirm the receipt of addenda may be cause for rejection of this bid. I further understand that any verbal representation made or assumed to be made during any oral discussion held between Vendor's representatives and any state personnel is not binding. Only the information issued in writing and added to the specifications by an official addendum is binding.

ALL Pumps Sales + Services, Inc.
Company
Tom Zeller
Authorized Signature
10/4/23
Date

NOTE: This addendum acknowledgment should be submitted with the bid to expedite document processing.
Revised 6/8/2012

SOLICITATION NUMBER: CRFQ 0310 DNR2400000004

Addendum Number: No.01

The purpose of this addendum is to modify the solicitation identified as (“Solicitation”) to reflect the change(s) identified and described below.

Applicable Addendum Category:

- Modify bid opening date and time
- Modify specifications of product or service being sought
- Attachment of vendor questions and responses
- Attachment of pre-bid sign-in sheet
- Correction of error
- Other

Description of Modification to Solicitation:

Addendum issued to publish and distribute the attached documentation to the vendor community.

1. To move the bid close date to 10/05/2023 @ 1:30 PM ET
2. To publish agency responses to all vendor submitted questions
3. To publish pre-bid sign in sheet

Additional Documentation: Documentation related to this Addendum (if any) has been included herewith as Attachment A and is specifically incorporated herein by reference.

Terms and Conditions:

1. All provisions of the Solicitation and other addenda not modified herein shall remain in full force and effect.
2. Vendor should acknowledge receipt of all addenda issued for this Solicitation by completing an Addendum Acknowledgment, a copy of which is included herewith. Failure to acknowledge addenda may result in bid disqualification. The addendum acknowledgement should be submitted with the bid to expedite document processing.

ATTACHMENT A

**WV Division of Natural Resources
Parks & Recreation Section**

**Hawks Nest State Park New Sewage Lift Station
CRFQ 0310 DNR2400000004**

The following is issued as Addendum No. 1 for the above-referenced project. This forms a part of the Contract Documents and modifies the original documents as noted below.

Attachments

1. Pre-bid meeting sign-in sheet.
2. Technical Questions with responses.
3. Digital file containing construction plans

Correction of Error

The following items were found to contain errors in the bidding documents as originally published:

The original digital file for the construction drawings was found to be corrupt and was not included in the attachments as published in the original solicitation. The construction drawings have been included herein as an attachment in digital format.

Pre-Bid Sign-In Sheet

Solicitation Number: CRFQ DNR2400000004

Date of Pre-Bid Meeting: September 7, 2023

Location of Prebid Meeting: Hawks Nest SP

Please Note:

Vendors must sign-in on this sheet to verify attendance at the Pre-Bid meeting. Failure to legibly sign in may be grounds for declaring a vendor ineligible to bid. For further verification, please also provide a business card if possible.

Firm Represented:*	Rep Name (Printed):	Firm Address:	Telephone #:	Fax #:	Email:
FAMCO, INC.	R. RICHMOND	P.O. Box 1577 HUNTINGTON, WV 25716	304-529-3328	304-529-3325	r.richmond.famco@gmail.com
BLUE TANK & PUMP	JARED STRATTON	US 23 LOUISA KY	304-690-2185		JSTRATTON@BLUETANKANDPUMP.COM
FOSTER SUPPLY	DERRICK SEARS	PO Box 488 SCOTT DEPOT WV 25560	304-553-6565	304-755-8280	dsears@fostersupply.com
BPI, Inc.	Christian Wells	PO Box 315 Teays, W.V. 25562 25569	304-760-8909	N/A	cwells@bpi-gc.com
ALL-Pumps, S&S Sq IPS + Service	TOM FRILLUP	2182 Rt 75 HARRISBURG WV 25533	304-453-5610	304-453-5640	tfrillup,pspp@zoominternet.net
Green River Group, LLC	Tracy Curtis	714 Venture Drive #18C Morgantown, WV 26508	304-203-4623	304-594-3992	tracyscurtis@yahoo.com

***One Vendor Per Representative - No one individual is permitted to represent more than one vendor at the pre-bid meeting. Any individual that does attempt to represent two or more vendors will be required to select one vendor to which the individual's attendance will be attributed. The vendors not selected will be deemed to have not attended the pre-bid meeting unless another individual attended on their behalf.**

Pre-Bid Sign-In Sheet

Solicitation Number: CRFQ DNR2400000004

Date of Pre-Bid Meeting: September 7, 2023

Location of Prebid Meeting: Hawks Nest SP

Please Note:

Vendors must sign-in on this sheet to verify attendance at the Pre-Bid meeting. Failure to legibly sign in may be grounds for declaring a vendor ineligible to bid. For further verification, please also provide a business card if possible.

<u>Firm Represented:*</u>	<u>Rep Name (Printed):</u>	<u>Firm Address:</u>	<u>Telephone #:</u>	<u>Fax #:</u>	<u>Email:</u>
Bear Contracting, LLC	Brian Henderson	1 Columbi-Blvd. Clarksburg, WV, 26301	304-326-0160	304-326-0054	estimating@bear-contracting.com
PREMIER GROUP	JEREMIAH TUGGLE	447 MARKET ST. PETERSTOWN, WV 24963	304-646-0115		jtuggle@premiergroupLP.com
Central Supply of WV	Matt Bostic	7900 Webster Rd Summersville, WV	304-646-4484		Matt.bostic@ Centralsupplywv.com
Alpha Assoc. Inc	Rick Colobank	209 Prairie Ave Morgantown, WV 26501	304-216-8324		nick.colobank@ thinkalphafirst.com
WVDNR	Don Bailey, III	324 4th Ave. S. Chas., WV 25303	(304) 558-2764		Donald.E.Baileyiii@wv.gov
WVDNR	DON BAILEY, JR	324 4TH AVE. So. CHAS., WV 25303	(304) 558-2764		donald.e.bailey@ wv.gov.

***One Vendor Per Representative - No one individual is permitted to represent more than one vendor at the pre-bid meeting. Any individual that does attempt to represent two or more vendors will be required to select one vendor to which the individual's attendance will be attributed. The vendors not selected will be deemed to have not attended the pre-bid meeting unless another individual attended on their behalf.**

HAWKS NEST NEW SEWAGE LIFT STATION

CRFQ DNR 24*04

RFI: Vendor Questions

September 19, 2023

Q.1. Inset 1 references 6" PVC gravity entering the wet-well. The SSMH upstream of the wet-well references 10" TC leaving the manhole and entering the wet-well. Please confirm the diameter and pipe type entering the wet-well from the east.

A. *Existing Pipe from the lodge is a 10" TC. The new pipe will be a 10" SDR35 to the new pump station. All elevations will be maintained as per the plans.*

Q.2. Confirm if aggregate backfill is required in trenches.

A. *Trench Detail for variable grade sanitary sewer and force main requires only satisfactory soil material excavated from the trench free of stones larger than 3 inches in size and free of wet, frozen, or organic material. Trench Detail for gravity sanitary sewer, storm sewer + culvert requires WVDOH Aggregate Base Course, Class 1 to a depth of at least 6 inches above the crown of the pipe followed by satisfactory soil material excavated from the trench free of stones larger than 3 inches in size and free of wet, frozen, or organic material. This applies to all trenches.*

Q.3. Do the bid documents assume no rock excavation is required?

A. *It is not anticipated that rock excavation will be required during installation of sewer lines. However, if rock requiring excavation is encountered, it will be addressed in a change order.*

Q.4. The Lift Station and Valve Vault Section illustrated on Plan Sheet C500 note a 60" diameter wet well. However, there is a wet well dimension illustrating a 48" diameter. Please confirm the diameter of the new wet well.

A. *48" Diameter Wet Well*

Q.5. Can you confirm that the diameter of the wet well is 4ft?

A. *48" Diameter Wet Well*

Q.6. Is there a B&O tax? What is the rate? Business license? Construction License?

A. *Contractors will be responsible for contacting the Town of Ansted for the information on B&O tax rate and any licenses required.*

Q.7. Will rock excavation be paid as extra, if encountered? This was brought up at the pre-bid meeting.

A. *It is not anticipated that rock excavation will be required during installation of sewer lines. However, if rock requiring excavation is encountered, it will be addressed in a change order.*

Q.8. Are there any restrictions on accessing the lift station site?

A. *There are no restrictions on accessing the existing lift station. The only requirement is that the Contractor must make every effort to maintain operation of the existing lift station during peak flow.*

Q.9. What are the flows to the existing lift station?

A. *Average Daily Flow of 850 Gal/Day*

Q.10. What material is the existing force-main constructed from?

A. *It is anticipated the existing Force Main is construction of either Ductile or Cast Iron.*

Q.11. Can you confirm that the new gravity sewer is to be SDR 35?

A. *Confirmed*

Q.12. Can you confirm that the new force-main is to be SDR21?

A. *Confirmed*

Q.13. Can the brush from clearing be chipped and the logs left on-site?

A. *Removal of brush should be minimal and can be chipped and left on-site. Removal of trees should not be required.*

Q.14. Can you confirm that the existing electrical will be used for the new lift station?

A. *Power will be from the power at the existing station. Contractor shall provide shut off and panels as per electric code with NEMA 3 watertight enclosures as necessary.*

Q.15. Must aggregate material be used for the abandonment of the existing station, if abandoned in place?

A. *Contractor shall provide either aggregate or acceptable soil material in backfill when demolishing the existing pump station. If Concrete from the pump station is utilized, it must be crushed/broken to a maximum size of 8" and properly compacted to insure minimal settlement.*

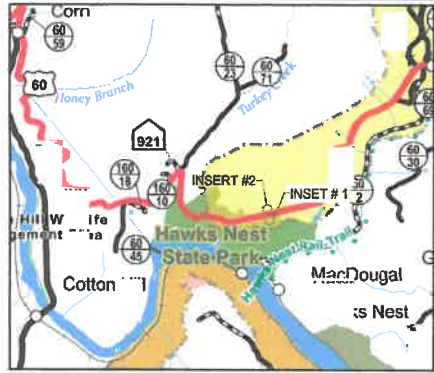

VICINITY MAP 1" = 2000'
FAYETTE COUNTY, WV

EXISTING PUMP STATION DATA:

- PUMP MODEL # S4 MX 750 JC
 - PANEL NUMBER S3117-000-7
- PLEASE REVIEW PICTURE OF STATION INFORMATION. THESE NUMBERS ARE TO CLARIFY WHAT CAN NOT BE READ IN THE PICTURE

LEGEND

- ⊙ SANITARY MANHOLE
- ⊕ SEWER VALVE
- ⊖ SANITARY CLEAN-OUT
- ⊗ EDGE OF GRAVEL
- 6" CONTOUR INTERVAL
- 1' CONTOUR INTERVAL
- SANITARY SEWER LINE

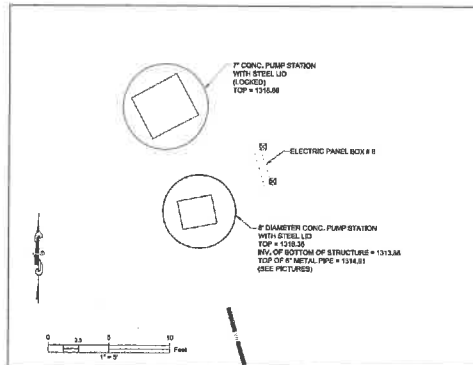
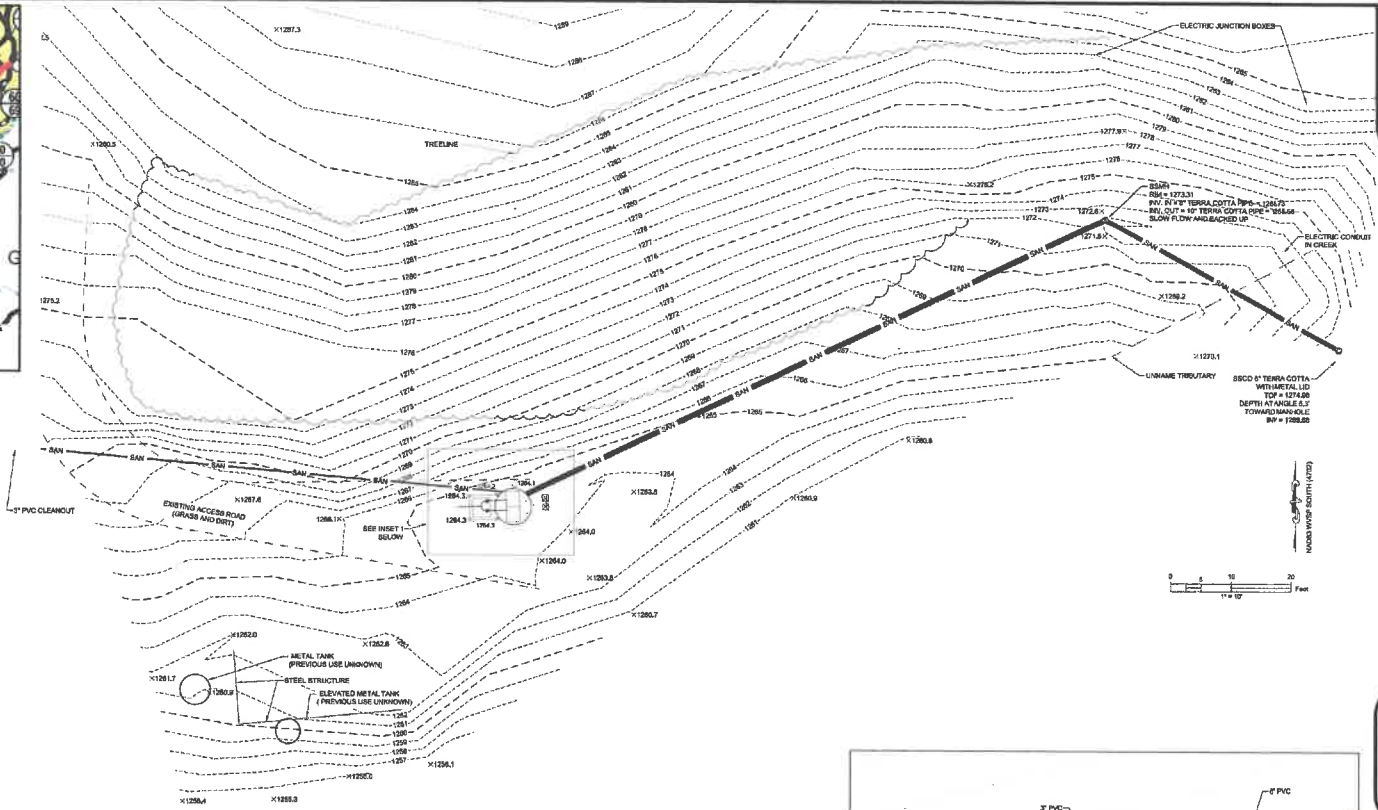

INSET 2 - EXISTING PUMP STATION # 8

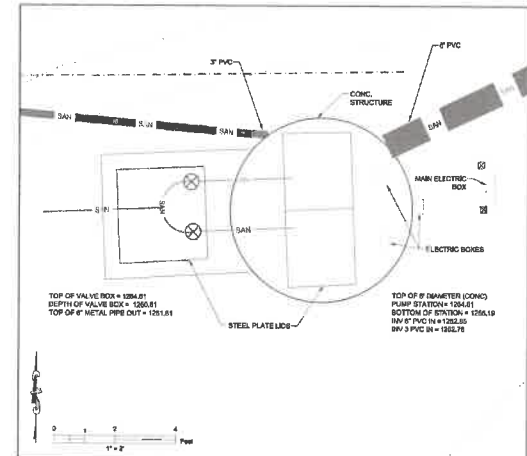

INSET 1
EXISTING PUMP STATION BELOW LODGE



**HAWKS NEST STATE PARK
PUMP STATION REPLACEMENT PROJECT**
NEW HAVEN DISTRICT
FAYETTE COUNTY, WEST VIRGINIA

KEYPLAN

REVISIONS

NO.	ITEM	DATE

PROJ. NO.: 2208101.00
DATE: 02/14/2023
SHEET NO.:

C100

ALPHA ASSOCIATES, INC. ALL RIGHTS RESERVED

EXISTING CONDITIONS

NO.	ITEM	DATE

PROJ. NO.: 2206101.00
DATE: 02/14/2023
SHEET NO.:

C102

Copyright © 2023 Alpha Associates, Inc. All rights reserved.

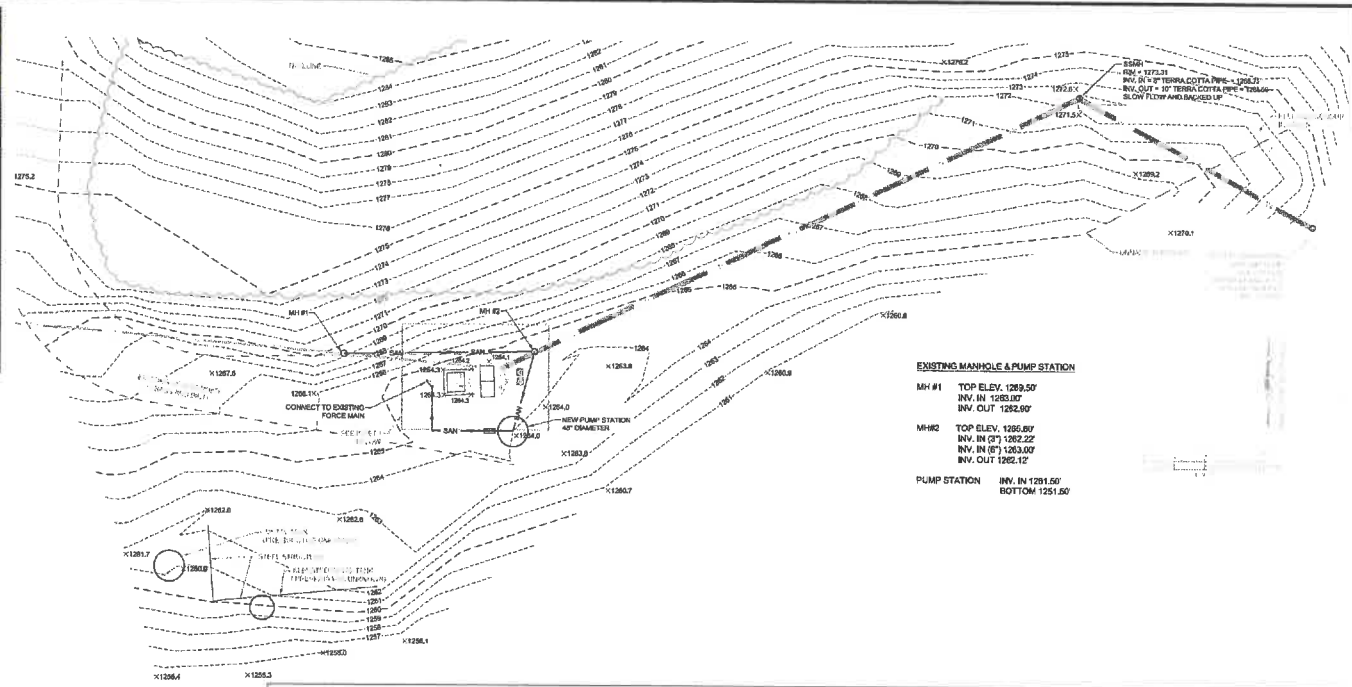

EXISTING MANHOLE & PUMP STATION

MH #1	TOP ELEV. 1269.50
	INV. IN 1263.07
	INV. OUT 1262.60
MH#2	TOP ELEV. 1266.80
	INV. IN (8") 1263.22
	INV. IN (6") 1263.00
	INV. OUT 1262.12
PUMP STATION	INV. IN 1261.50
	BOTTOM 1251.50

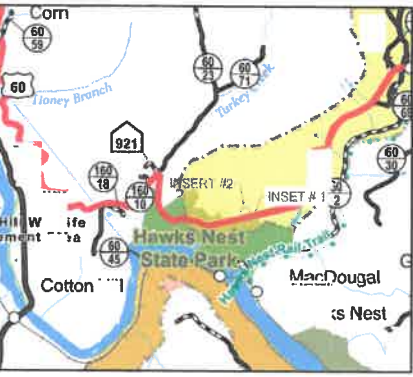

VICINITY MAP 1" = 2000'
FAYETTE COUNTY, WV

EXISTING PUMP STATION DATA

- * PUMP STATION # 2 IS MAXIMUM SIZE
- * PUMP STATION # 1 IS 17' DIAMETER
- * PLEASE REFER TO PICTURE OF STATION INFORMATION
- * THESE NUMBERS ARE TO CLARIFY WHAT CANNOT BE READ IN THE PICTURE

LEGEND

- ⊙ SANITARY MANHOLE
- ⊙ SEWER VALVE
- ⊙ SANITARY CLEAN-OUT
- - - EDGE OF GRAVEL
- - - 6" CONTROL INTERVAL
- - - 12" CONTROL INTERVAL
- - - SANITARY SEWER LINE - EXISTING
- - - SANITARY SEWER LINE - PROPOSED

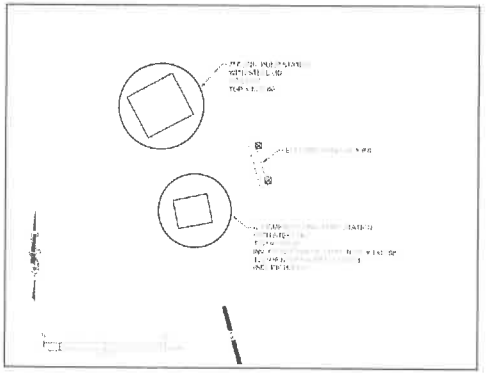

INSET 2 - EXISTING PUMP STATION # 8

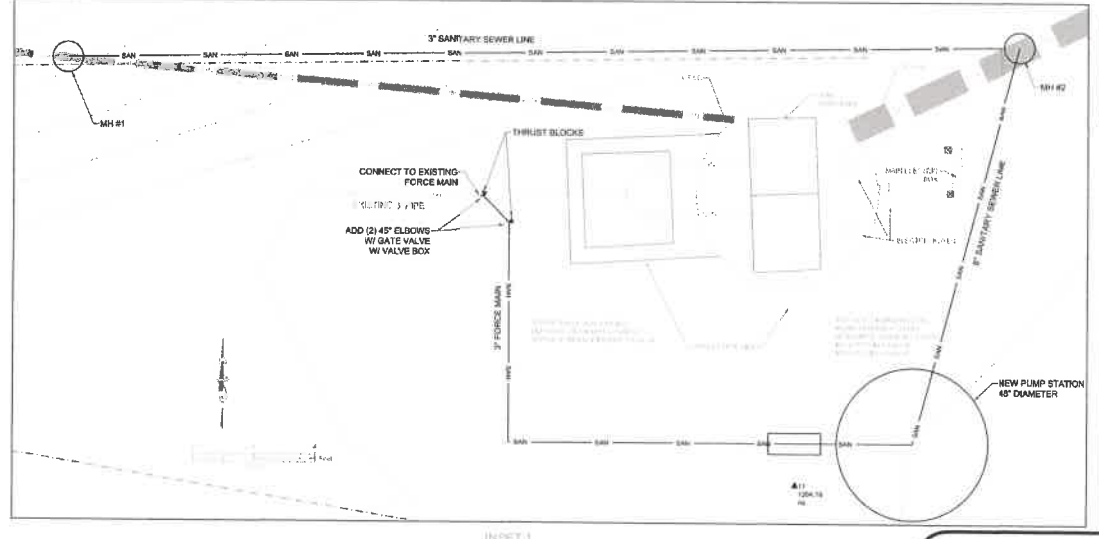

INSET 1 - EXISTING PUMP STATION BELOW LODGE

Z:\Projects\2022_Job\12206101\000\Current\Construction\C102.dwg SITE PLAN - Feb 14 2023 04:44:09 pm PLOTTED BY: jfrazee



ALPHA ASSOCIATES, INC.
500 PRAIRIE AVENUE
INDIANAPOLIS, IN 46201
PHONE/FAC: 316-278-8216
TOLL FREE: 800-340-8315
WWW.ALPHAINC.COM

**HAWKS NEST STATE PARK
PUMP STATION REPLACEMENT PROJECT**
NEW HAVEN DISTRICT
FAYETTE COUNTY, WEST VIRGINIA

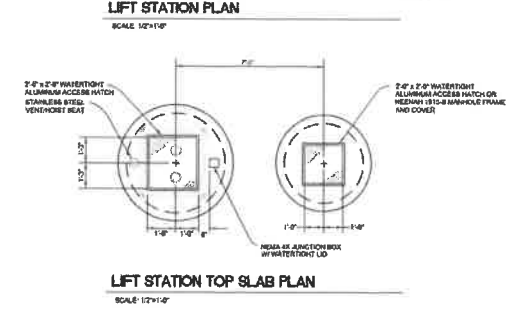
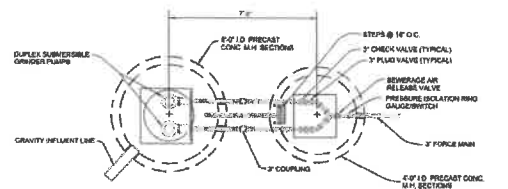
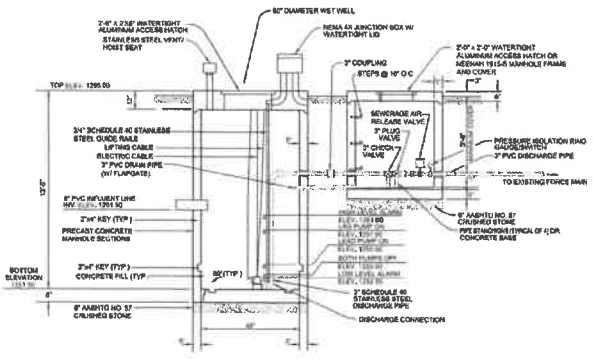

NOTES:

1. ALL CONCRETE SHALL MEET OR EXCEED ASTM C475 AND SHALL HAVE A MINIMUM 28-DAY STRENGTH OF 4000 PSI. ALL REINFORCING STEEL SHALL BE GRADE 60. ALL SECTIONS SHALL BE JOINED WITH BUTYLMASTIC AND SHALL BE ADEQUATELY CURBED. ALL INTERNAL JOINT SURFACES SHALL BE TRIMMED SMOOTH USING A BITUMINOUS WATERPROOFING MATERIAL. ALL OF THE INTERIOR SHALL BE COATED WITH CS-55 SEALANT. ALL TEARS SET IN PLACE DURING POURING SHALL BE ANCHORED WITH 4000 PSI STAINLESS STEEL ANCHOR BOLTS. RESILIENT PIPE-TO-MANHOLE CONNECTIONS (ASTM C923) SHALL BE PROVIDED AT ALL PIPE PENETRATIONS.
2. THE CHECK VALVES SHALL BE BALL CHECK VALVES OF CAST IRON CONSTRUCTION WITH HOLLOW STEEL BALL COATED WITH VULCANIZED NITRIL RUBBER. THE BALL CHECK VALVES SHALL BE RATED FOR A MINIMUM PRESSURE OF 150 PSI.
3. FLDG VALVES ARE TO BE OF THE NON-LUBRICATED ECCENTRIC PLUG TYPE. VALVES ARE TO BE RATED FOR 175 LB. WOG AND CAST IN ASTM A126 CLASS B CAST IRON. ALL VALVES MUST HAVE A FULL ROUND PORT TO ASSURE MINIMUM TURBULENCE AND MINIMUM PRESSURE DROP. VALVES ARE TO HAVE A BALANCE PLUG, COATED WITH BUNA-N NEOPRENE OR OTHER MATERIAL AS REQUIRED TO ASSURE LOW TORQUE AND BUBBLE-TIGHT SHUT-OFF. VALVES TO BE CORROSION RESISTANT. SEAT IS TO BE RAISED, WELDED NICKEL.
4. STEPS IN THE VALVE PIT SHALL BE PREFORMED STEEL REINFORCED BAR ENCAPSULATED WITH INJECTION MOLDED POLYPROPYLENE WITH SERATED TRAPEZOIDAL END LUGS TO PREVENT FEET FROM SLIPPING.
5. THE MANUFACTURER SHALL PROVIDE THE SERVICES OF A FACTORY TRAINED TECHNICIAN FOR ONE (1) DAY FOR INITIAL START-UP OF THE STATION AND FOR INSTRUCTION OF THE OWNERS OPERATION AND MAINTENANCE PERSONNEL.
6. SUBMERSIBLE GRINDER PUMPS SHALL OPERATE ON 1 HP 230 VOLT SINGLE PHASE POWER. EACH SHALL BE CAPABLE OF DELIVERING A MINIMUM OF 12 GPM AT 70 FEET OF TOTAL DYNAMIC HEAD. EACH SHALL ALSO OPERATE AT A TOTAL DYNAMIC HEAD AS LOW AS 48 FEET, WITHOUT CAVITATION. 300 GALLONS OF STORAGE SHALL BE PROVIDED BETWEEN THE "BOTH PUMPS OFF" LEVEL AND THE "HIGH LEVEL ALARM" LEVEL. PUMPS SHALL BE AN E-1 DUPLEX GRINDER PUMPS 1 HP 1725 RPM OR APPROVED EQUAL.
7. THE AUTOMATIC CONTROL CENTER SHALL BE MANUFACTURED BY THE PUMP STATION MANUFACTURER AND SHALL BE MOUNTED AT THE PUMP STATION. THE PANEL SHALL BE NEMA 4X. THE POWER SUPPLY SHALL BE 200 VOLTS 3 PHASE 60 HERTZ. THE CONTROL PANEL SHALL CONTROL THE PUMPS BASED ON LIQUID LEVEL AND THE PRESSURE SWITCH LOCATED IN THE VALVE PIT. PUMPING SHALL BEGIN WHEN THE "LEAD PUMP ON" LEVEL IS REACHED. PUMPING SHALL STOP WHEN THE "BOTH PUMPS OFF" LEVEL IS REACHED. THE PANEL SHALL INCLUDE APPROPRIATE MOLDED CASE INDUSTRIAL BREAKERS, MAGNETIC MOTOR STARTERS, AND A HAND/OFF/AUTOMATIC SELECTOR SWITCH. PUMPS SHALL ALTERNATE AFTER EACH PUMPING CYCLE. THE CONTROL PANEL SHALL ALSO PROVIDE FOR EACH PUMP A TEMPERATURE SENSOR ALARM/SHUTDOWN, OVERLOAD RELAY ALARM/SHUTDOWN WITH MANUAL RESET, A PUMP FAILURE ALARM, RUN LIGHTS, NON-RESETTABLE ELAPSED TIME METER, AND MOISTURE SENSOR ALARM. A LOW LEVEL, ALARM AND A HIGH LEVEL ALARM WITH A FLASHING RED LIGHT SHALL BE PROVIDED. DRY CONTACTS SHALL BE PROVIDED FOR THE ALARM MONITOR AT A REMOTE LOCATION. EACH MERCURY FLOAT SHALL HAVE PANEL LIGHTS TO INDICATE POSITION. AN ACKNOWLEDGED PUSH-BUTTON SWITCH SHALL BE PROVIDED TO DEACTIVATE AND RESET THE LOCAL ALARM. A LIGHTNING ARRESTOR SHALL BE PROVIDED. A POWER MONITOR ALARM SHALL BE PROVIDED TO INDICATE LOW VOLTAGE, HIGH VOLTAGE, PHASE UNBALANCE, OR SINGLE PHASE. RELAYS SHALL BE PROVIDED TO STOP START PUMPS IN THE EVENT OF POWER FAILURE. A TEMPERATURE SELF-LIMITING CONDENSATION HEATER SHALL BE PROVIDED. EXTERNAL QUICK DISCONNECT SWITCHES SHALL BE PROVIDED.
8. THE MANUFACTURER OF THE LIFT STATION SHALL GUARANTEE FOR ONE (1) YEAR FROM THE DATE OF INSTALLATION, OR 18 MONTHS FROM THE DATE OF SHIPMENT, THAT THE STRUCTURE AND ALL EQUIPMENT WILL BE FREE FROM DEFECTS IN DESIGN, MATERIAL, AND WORKMANSHIP. WARRANTIES AND GUARANTEES BY THE SUPPLIER OF VARIOUS COMPONENTS IN LIEU OF A SINGLE SOURCE RESPONSIBILITY BY THE MANUFACTURER WILL NOT BE ACCEPTED. THE MANUFACTURER SHALL BE SOLELY RESPONSIBLE FOR THE GUARANTEE OF THE STATION AND ALL COMPONENTS. IN THE EVENT A COMPONENT FAILS TO PERFORM AS SPECIFIED OR IS PROVIDED DEFECTIVE IN SERVICE DURING THE GUARANTEE PERIOD, THE MANUFACTURER SHALL PROVIDE A REPLACEMENT PART, WITHOUT COST, TO THE OWNER. HE SHALL FURTHER PROVIDE, WITHOUT COST, SUCH LABOR AS MAY BE REQUIRED TO REPLACE, REPAIR OR MODIFY MAJOR COMPONENTS SUCH AS THE STATION STRUCTURE, PUMPS, PUMP MOTORS, SEWAGE PIPING MANIFOLD, ETC.
9. ALL EXCAVATION/BACKFILL SHALL BE DONE IN ACCORDANCE WITH THE LATEST WVDON SPECIFICATIONS.
10. ALL WORKMANSHIP AND MATERIALS SHALL CONFORM TO CURRENT WV DEPARTMENT OF HEALTH DEPARTMENT REQUIREMENTS.

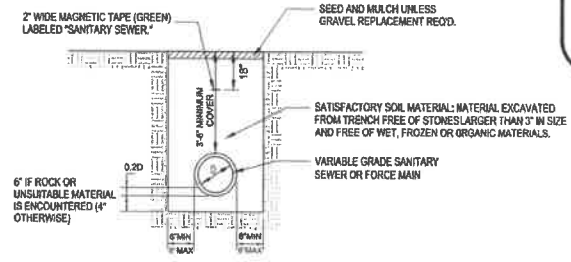

TRENCH DETAIL A FOR VARIABLE GRADE SANITARY SEWER AND FOR FORCE MAIN
NOT TO SCALE

NOTES:

1. THE CONTRACTOR SHALL BACKFILL ALL TRENCHES IN LIFTS NOT MORE THAN 8 INCHES IN LOOSE DEPTH FOR MATERIAL COMPACTED BY HEAVY COMPACTION EQUIPMENT AND NOT MORE THAN 4 INCHES BELOW BOTTOM FOR MATERIAL COMPACTED BY HAND OPERATED TAMPERS. ALL TRENCH BACKFILL SHALL BE COMPACTED TO AT LEAST 90% OF THE MAXIMUM DRY UNIT WEIGHT ACCORDING TO THE STANDARD PROCTOR METHOD (ASTM D998). THE CONTRACTOR SHALL ENGAGE A QUALIFIED INDEPENDENT GEOTECHNICAL ENGINEERING TESTING AGENCY TO PERFORM FIELD QUALITY CONTROL TESTS. TESTS SHALL BE PERFORMED EVERY 100 LINEAR FEET OF TRENCH EVERY LAYER, THREE (3) LAYERS OF ALL TEST RESULTS SHALL BE PROVIDED BY THE INDEPENDENT TESTING AGENCY DIRECTLY TO THE ENGINEER. ALL BACKFILLS NOT MEETING THE DEGREE OF COMPACTION SPECIFIED SHALL BE REMOVED, RECOMPACTED, AND RETESTED UNTIL THE SPECIFIED COMPACTION IS OBTAINED.
2. THE CONTRACTOR SHALL REMOVE AND LEGALLY DISPOSE OF ALL SURPLUS EXCAVATED MATERIAL.

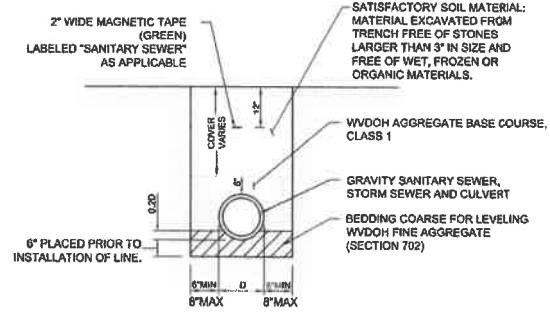

TRENCH DETAIL FOR GRAVITY SANITARY SEWER, STORM SEWER + CULVERT
NO SCALE

DEMOLITION NOTES:

1. UPON COMPLETION OF NEW PUMP STATION, CONTRACTOR SHALL DEMOLISH EXISTING PUMP STATION BY EITHER TOTALLY REMOVING WET WELL AND VALVE BOX OR BREAKING UP BOTTOMS AND BACKFILLING WITH ACCEPTABLE MATERIAL. BACKFILL SHALL BE APPROVED BY THE ENGINEER. ALL ITEMS DEMOLISHED SHALL BE DISPOSED OF IN A LEGAL MANNER. PROOF OF DISPOSAL SHALL BE SUPPLIED.

KEYPLAN

REVISIONS

NO.	ITEM	DATE

PROJ. NO.: 2208101.00
DATE: 02/14/2023
SHEET NO.:

C500
CONSTRUCTION SOFTWARE INC.
ALL RIGHTS RESERVED

DETAILS

20230215 10:02:26 Job: 220810101 Current Construction Details - Details - 1/23/23 09:14:44 AM PLOTTED BY: JFRANK

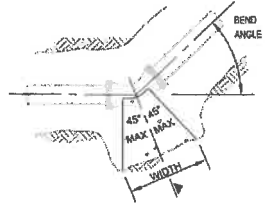

TYPICAL BEND



TYPICAL SECTION

NOTE: BEARING AREAS ARE BASED ON 100 P.S.I. TEST PRESSURE, A SOIL RESISTANCE OF 1000 P.S.F., AND A SAFETY FACTOR OF 1.5. IF WEAK (LESS THAN 1000 P.S.F. RESISTANCE) SOIL POCKETS ARE ENCOUNTERED, INCREASE THE BEARING AREAS SHOWN TO PREVENT MOVEMENT UNDER TEST OR OPERATING PRESSURES.

PIPE SIZE	MINIMUM BEARING AREA (S.F.) = WIDTH X HEIGHT				TEE, CAP, OR PLUG
	90° BEND	45° BEND	22-1/2° BEND	11-1/4° BEND	
2"	0.7	0.4	0.2	0.1	0.5
2 1/2"	1.5	0.8	0.5	0.3	1.1
3"	1.8	0.9	0.5	0.3	1.2
4"	2.7	1.5	0.8	0.4	1.8
6"	6.0	3.3	1.7	0.9	4.3

THRUST BLOCKS SHALL BE CLASS 3000 M CONCRETE

NOTES:

- (1) BEARING SURFACE SHALL BE PLACED AGAINST UNDISTURBED SOIL. WHERE THIS IS NO POSSIBLE, COMPACT FILL BETWEEN BEARING SURFACE AN UNDISTURBED SOIL TO AT LEAST 90% STANDARD PROCTOR DENSITY.
- (2) BLOCK HEIGHT SHALL NOT EXCEED 1/2 OF THE TOTAL DEPTH TO THE BOTTOM OF THE BLOCK, BUT NOT LESS THAN THE PIPE DIAMETER.
- (3) BLOCK WIDTH SHALL BE 1 TO 2 TIMES THE BLOCK HEIGHT.
- (4) PROVIDE CLEARANCE FOR BOLT REMOVAL.

FORCE MAIN AND VARIABLE GRADE SEWER THRUST BLOCKING

KEYPLAN

REVISIONS

NO.	TYPE	DATE

PROJ. NO.: 2208101.00
DATE: 02/14/2023
SHEET NO.:

C501

ALPHA ASSOCIATES, INC. ALL RIGHTS RESERVED

DETAILS

INSTRUCTIONS TO VENDORS SUBMITTING BIDS

1. REVIEW DOCUMENTS THOROUGHLY: The attached documents contain a solicitation for bids. Please read these instructions and all documents attached in their entirety. These instructions provide critical information about requirements that if overlooked could lead to disqualification of a Vendor's bid. All bids must be submitted in accordance with the provisions contained in these instructions and the Solicitation. Failure to do so may result in disqualification of Vendor's bid.

2. MANDATORY TERMS: The Solicitation may contain mandatory provisions identified by the use of the words "must," "will," and "shall." Failure to comply with a mandatory term in the Solicitation will result in bid disqualification.

3. PREBID MEETING: The item identified below shall apply to this Solicitation.

A pre-bid meeting will not be held prior to bid opening

A **MANDATORY PRE-BID** meeting will be held at the following place and time:

Hawks Nest State Park
49 Hawks Nest Park Road
Ansted, WV 25812

On 09/07/2023 at 10:00 A.M.
Meet at the lodge parking lot.

All Vendors submitting a bid must attend the mandatory pre-bid meeting. Failure to attend the mandatory pre-bid meeting shall result in disqualification of the Vendor's bid. No one individual is permitted to represent more than one vendor at the pre-bid meeting. Any individual that does attempt to represent two or more vendors will be required to select one vendor to which the individual's attendance will be attributed. The vendors not selected will be deemed to have not attended the pre-bid meeting unless another individual attended on their behalf.

An attendance sheet provided at the pre-bid meeting shall serve as the official document verifying attendance. Any person attending the pre-bid meeting on behalf of a Vendor must list on the attendance sheet his or her name and the name of the Vendor he or she is representing.

Additionally, the person attending the pre-bid meeting should include the Vendor's E-Mail address, phone number, and Fax number on the attendance sheet. It is the Vendor's responsibility to locate the attendance sheet and provide the required information. Failure to complete the attendance sheet as required may result in disqualification of Vendor's bid.

All Vendors should arrive prior to the starting time for the pre-bid. Vendors who arrive after the starting time but prior to the end of the pre-bid will be permitted to sign in but are charged with knowing all matters discussed at the pre-bid.

Questions submitted at least five business days prior to a scheduled pre-bid will be discussed at the pre-bid meeting if possible. Any discussions or answers to questions at the pre-bid meeting are preliminary in nature and are non-binding. Official and binding answers to questions will be published in a written addendum to the Solicitation prior to bid opening.

4. VENDOR QUESTION DEADLINE: Vendors may submit questions relating to this Solicitation to the Purchasing Division. Questions must be submitted in writing. All questions must be submitted on or before the date listed below and to the address listed below to be considered. A written response will be published in a Solicitation addendum if a response is possible and appropriate. Non-written discussions, conversations, or questions and answers regarding this Solicitation are preliminary in nature and are nonbinding.

Submitted emails should have the solicitation number in the subject line.

Question Submission Deadline: 09/14/2023 @ 4:00 PM ET

Submit Questions to: Josh Hager
2019 Washington Street, East
Charleston, WV 25305
Fax: (304) 558-3970
Email: Joseph.E.HagerIII@wv.gov

5. VERBAL COMMUNICATION: Any verbal communication between the Vendor and any State personnel is not binding, including verbal communication at the mandatory pre-bid conference. Only information issued in writing and added to the Solicitation by an official written addendum by the Purchasing Division is binding.

6. BID SUBMISSION: All bids must be submitted on or before the date and time of the bid opening listed in section 7 below. Vendors can submit bids electronically through wvOASIS, in paper form delivered to the Purchasing Division at the address listed below either in person or by courier, or in facsimile form by faxing to the Purchasing Division at the number listed below. Notwithstanding the foregoing, the Purchasing Division may prohibit the submission of bids electronically through wvOASIS at its sole discretion. Such a prohibition will be contained and communicated in the wvOASIS system resulting in the Vendor's inability to submit bids through wvOASIS. The Purchasing Division will not accept bids, modification of bids, or addendum acknowledgment forms via email. Bids submitted in paper or facsimile form must contain a signature. Bids submitted in wvOASIS are deemed to be electronically signed.

Any bid received by the Purchasing Division staff is considered to be in the possession of the Purchasing Division and will not be returned for any reason.

For Request for Proposal ("RFP") Responses Only: Submission of a response to a Request for Proposal is not permitted in wvOASIS. In the event that Vendor is responding to a request for proposal, the Vendor shall submit one original technical and one original cost proposal prior to the bid opening date and time identified in Section 7 below, plus ^{NA} _____ convenience copies of each to the Purchasing Division at the address shown below. Additionally, the Vendor should clearly identify and segregate the cost proposal from the technical proposal in a separately sealed envelope.

Bid Delivery Address and Fax Number:

Department of Administration, Purchasing Division
2019 Washington Street East
Charleston, WV 25305-0130
Fax: 304-558-3970

A bid submitted in paper or facsimile form should contain the information listed below on the face of the submission envelope or fax cover sheet. Otherwise, the bid may be rejected by the Purchasing Division.

VENDOR NAME:

BUYER: Josh Hager

SOLICITATION NO.: CRFQ 0310 DNR2400000004

BID OPENING DATE: See next page

BID OPENING TIME: See next page

FAX NUMBER: 304-558-3970

7. BID OPENING: Bids submitted in response to this Solicitation will be opened at the location identified below on the date and time listed below. Delivery of a bid after the bid opening date and time will result in bid disqualification. For purposes of this Solicitation, a bid is considered delivered when confirmation of delivery is provided by wvOASIS (in the case of electronic submission) or when the bid is time stamped by the official Purchasing Division time clock (in the case of hand delivery).

Bid Opening Date and Time: ~~09/26/2022 @ 1:00 PM ET~~

Bid Opening Location: Department of Administration, Purchasing Division
2019 Washington Street East
Charleston, WV 25305-0130

8. ADDENDUM ACKNOWLEDGEMENT: Changes or revisions to this Solicitation will be made by an official written addendum issued by the Purchasing Division. Vendor should acknowledge receipt of all addenda issued with this Solicitation by completing an Addendum Acknowledgment Form, a copy of which is included herewith. Failure to acknowledge addenda may result in bid disqualification. The addendum acknowledgement should be submitted with the bid to expedite document processing.

9. BID FORMATTING: Vendor should type or electronically enter the information onto its bid to prevent errors in the evaluation. Failure to type or electronically enter the information may result in bid disqualification.

10. ALTERNATE MODEL OR BRAND: Unless the box below is checked, any model, brand, or specification listed in this Solicitation establishes the acceptable level of quality only and is not intended to reflect a preference for, or in any way favor, a particular brand or vendor. Vendors may bid alternates to a listed model or brand provided that the alternate is at least equal to the model or brand and complies with the required specifications. The equality of any alternate being bid shall be determined by the State at its sole discretion. Any Vendor bidding an alternate model or brand should clearly identify the alternate items in its bid and should include manufacturer's specifications, industry literature, and/or any other relevant documentation demonstrating the equality of the alternate items. Failure to provide information for alternate items may be grounds for rejection of a Vendor's bid.

This Solicitation is based upon a standardized commodity established under W. Va. Code § 5A-3-61. Vendors are expected to bid the standardized commodity identified. Failure to bid the standardized commodity will result in your firm's bid being rejected.

11. EXCEPTIONS AND CLARIFICATIONS: The Solicitation contains the specifications that shall form the basis of a contractual agreement. Vendor shall clearly mark any exceptions, clarifications, or other proposed modifications in its bid. Exceptions to, clarifications of, or modifications of a requirement or term and condition of the Solicitation may result in bid disqualification.

12. COMMUNICATION LIMITATIONS: In accordance with West Virginia Code of State Rules § 148-1-6.6, communication with the State of West Virginia or any of its employees regarding this Solicitation during the solicitation, bid, evaluation or award periods, except through the Purchasing Division, is strictly prohibited without prior Purchasing Division approval. Purchasing Division approval for such communication is implied for all agency delegated and exempt purchases.

13. REGISTRATION: Prior to Contract award, the apparent successful Vendor must be properly registered with the West Virginia Purchasing Division and must have paid the \$125 fee, if applicable.

14. UNIT PRICE: Unit prices shall prevail in cases of a discrepancy in the Vendor's bid.

15. PREFERENCE: Vendor Preference may be requested in purchases of motor vehicles or construction and maintenance equipment and machinery used in highway and other infrastructure projects. Any request for preference must be submitted in writing with the bid, must specifically identify the preference requested with reference to the applicable subsection of West Virginia Code § 5A-3-37, and must include with the bid any information necessary to evaluate and confirm the applicability of the requested preference. A request form to help facilitate the request can be found at:

www.state.wv.us/admin/purchase/vrc/Venpref.pdf.

15A. RECIPROCAL PREFERENCE: The State of West Virginia applies a reciprocal preference to all solicitations for commodities and printing in accordance with W. Va. Code § 5A-3-37(b). In effect, non-resident vendors receiving a preference in their home states, will see that same preference granted to West Virginia resident vendors bidding against them in West Virginia. Any request for reciprocal preference must include with the bid any information necessary to evaluate and confirm the applicability of the preference. A request form to help facilitate the request can be found at: www.state.wv.us/admin/purchase/vrc/Venpref.pdf.

16. SMALL, WOMEN-OWNED, OR MINORITY-OWNED BUSINESSES: For any solicitations publicly advertised for bid, in accordance with West Virginia Code §5A-3-37 and W. Va. CSR § 148-22-9, any non-resident vendor certified as a small, women-owned, or minority-owned business under W. Va. CSR § 148-22-9 shall be provided the same preference made available to any resident vendor. Any non-resident small, women-owned, or minority-owned business must identify itself as such in writing, must submit that writing to the Purchasing Division with its bid, and must be properly certified under W. Va. CSR § 148-22-9 prior to contract award to receive the preferences made available to resident vendors. Preference for a non-resident small, women-owned, or minority owned business shall be applied in accordance with W. Va. CSR § 148-22-9.

17. WAIVER OF MINOR IRREGULARITIES: The Director reserves the right to waive minor irregularities in bids or specifications in accordance with West Virginia Code of State Rules § 148-1-4.6.

18. ELECTRONIC FILE ACCESS RESTRICTIONS: Vendor must ensure that its submission in wvOASIS can be accessed and viewed by the Purchasing Division staff immediately upon bid opening. The Purchasing Division will consider any file that cannot be immediately accessed and viewed at the time of the bid opening (such as, encrypted files, password protected files, or incompatible files) to be blank or incomplete as context requires and are therefore unacceptable. A vendor will not be permitted to unencrypt files, remove password protections, or resubmit documents after bid opening to make a file viewable if those documents are required with the bid. A Vendor may be required to provide document passwords or remove access restrictions to allow the Purchasing Division to print or electronically save documents provided that those documents are viewable by the Purchasing Division prior to obtaining the password or removing the access restriction.

19. NON-RESPONSIBLE: The Purchasing Division Director reserves the right to reject the bid of any vendor as Non-Responsible in accordance with W. Va. Code of State Rules § 148-1-5.3, when the Director determines that the vendor submitting the bid does not have the capability to fully perform or lacks the integrity and reliability to assure good-faith performance.”

20. ACCEPTANCE/REJECTION: The State may accept or reject any bid in whole, or in part in accordance with W. Va. Code of State Rules § 148-1-4.5. and § 148-1-6.4.b.”

21. YOUR SUBMISSION IS A PUBLIC DOCUMENT: Vendor's entire response to the Solicitation and the resulting Contract are public documents. As public documents, they will be disclosed to the public following the bid/proposal opening or award of the contract, as required by the competitive bidding laws of West Virginia Code §§ 5A-3-1 et seq., 5-22-1 et seq., and 5G-1-1 et seq. and the Freedom of Information Act West Virginia Code §§ 29B-1-1 et seq.

DO NOT SUBMIT MATERIAL YOU CONSIDER TO BE CONFIDENTIAL, A TRADE SECRET, OR OTHERWISE NOT SUBJECT TO PUBLIC DISCLOSURE.

Submission of any bid, proposal, or other document to the Purchasing Division constitutes your explicit consent to the subsequent public disclosure of the bid, proposal, or document. The Purchasing Division will disclose any document labeled "confidential," "proprietary," "trade secret," "private," or labeled with any other claim against public disclosure of the documents, to include any "trade secrets" as defined by West Virginia Code § 47-22-1 et seq. All submissions are subject to public disclosure without notice.

22. WITH THE BID REQUIREMENTS: In instances where these specifications require documentation or other information with the bid, and a vendor fails to provide it with the bid, the Director of the Purchasing Division reserves the right to request those items after bid opening and prior to contract award pursuant to the authority to waive minor irregularities in bids or specifications under W. Va. CSR § 148-1-4.6. This authority does not apply to instances where state law mandates receipt with the bid.

23. EMAIL NOTIFICATION OF AWARD: The Purchasing Division will attempt to provide bidders with e-mail notification of contract award when a solicitation that the bidder participated in has been awarded. For notification purposes, bidders must provide the Purchasing Division with a valid email address in the bid response. Bidders may also monitor wvOASIS or the Purchasing Division's website to determine when a contract has been awarded.

24. ISRAEL BOYCOTT CERTIFICATION: Vendor's act of submitting a bid in response to this solicitation shall be deemed a certification from bidder to the State that bidder is not currently engaged in, and will not for the duration of the contract, engage in a boycott of Israel. This certification is required by W. Va. Code § 5A-3-63.

GENERAL TERMS AND CONDITIONS:

1. CONTRACTUAL AGREEMENT: Issuance of an Award Document signed by the Purchasing Division Director, or his designee, and approved as to form by the Attorney General's office constitutes acceptance by the State of this Contract made by and between the State of West Virginia and the Vendor. Vendor's signature on its bid, or on the Contract if the Contract is not the result of a bid solicitation, signifies Vendor's agreement to be bound by and accept the terms and conditions contained in this Contract.

2. DEFINITIONS: As used in this Solicitation/Contract, the following terms shall have the meanings attributed to them below. Additional definitions may be found in the specifications included with this Solicitation/Contract.

2.1. "Agency" or "Agencies" means the agency, board, commission, or other entity of the State of West Virginia that is identified on the first page of the Solicitation or any other public entity seeking to procure goods or services under this Contract.

2.2. "Bid" or "Proposal" means the vendors submitted response to this solicitation.

2.3. "Contract" means the binding agreement that is entered into between the State and the Vendor to provide the goods or services requested in the Solicitation.

2.4. "Director" means the Director of the West Virginia Department of Administration, Purchasing Division.

2.5. "Purchasing Division" means the West Virginia Department of Administration, Purchasing Division.

2.6. "Award Document" means the document signed by the Agency and the Purchasing Division, and approved as to form by the Attorney General, that identifies the Vendor as the contract holder.

2.7. "Solicitation" means the official notice of an opportunity to supply the State with goods or services that is published by the Purchasing Division.

2.8. "State" means the State of West Virginia and/or any of its agencies, commissions, boards, etc. as context requires.

2.9. "Vendor" or "Vendors" means any entity submitting a bid in response to the Solicitation, the entity that has been selected as the lowest responsible bidder, or the entity that has been awarded the Contract as context requires.

3. CONTRACT TERM; RENEWAL; EXTENSION: The term of this Contract shall be determined in accordance with the category that has been identified as applicable to this Contract below:

Term Contract

Initial Contract Term: The Initial Contract Term will be for a period of _____ . The Initial Contract Term becomes effective on the effective start date listed on the first page of this Contract, identified as the State of West Virginia contract cover page containing the signatures of the Purchasing Division, Attorney General, and Encumbrance clerk (or another page identified as _____), and the Initial Contract Term ends on the effective end date also shown on the first page of this Contract.

Renewal Term: This Contract may be renewed upon the mutual written consent of the Agency, and the Vendor, with approval of the Purchasing Division and the Attorney General's office (Attorney General approval is as to form only). Any request for renewal should be delivered to the Agency and then submitted to the Purchasing Division thirty (30) days prior to the expiration date of the initial contract term or appropriate renewal term. A Contract renewal shall be in accordance with the terms and conditions of the original contract. Unless otherwise specified below, renewal of this Contract is limited to _____ successive one (1) year periods or multiple renewal periods of less than one year, provided that the multiple renewal periods do not exceed the total number of months available in all renewal years combined. Automatic renewal of this Contract is prohibited. Renewals must be approved by the Vendor, Agency, Purchasing Division and Attorney General's office (Attorney General approval is as to form only)

Alternate Renewal Term – This contract may be renewed for _____ successive _____ year periods or shorter periods provided that they do not exceed the total number of months contained in all available renewals. Automatic renewal of this Contract is prohibited. Renewals must be approved by the Vendor, Agency, Purchasing Division and Attorney General's office (Attorney General approval is as to form only)

Delivery Order Limitations: In the event that this contract permits delivery orders, a delivery order may only be issued during the time this Contract is in effect. Any delivery order issued within one year of the expiration of this Contract shall be effective for one year from the date the delivery order is issued. No delivery order may be extended beyond one year after this Contract has expired.

Fixed Period Contract: This Contract becomes effective upon Vendor's receipt of the notice to proceed and must be completed within 180 days.

Fixed Period Contract with Renewals: This Contract becomes effective upon Vendor's receipt of the notice to proceed and part of the Contract more fully described in the attached specifications must be completed within _____ days. Upon completion of the work covered by the preceding sentence, the vendor agrees that:

the contract will continue for _____ years;

the contract may be renewed for _____ successive _____ year periods or shorter periods provided that they do not exceed the total number of months contained in all available renewals. Automatic renewal of this Contract is prohibited. Renewals must be approved by the Vendor, Agency, Purchasing Division and Attorney General's Office (Attorney General approval is as to form only).

One-Time Purchase: The term of this Contract shall run from the issuance of the Award Document until all of the goods contracted for have been delivered, but in no event will this Contract extend for more than one fiscal year.

Construction/Project Oversight: This Contract becomes effective on the effective start date listed on the first page of this Contract, identified as the State of West Virginia contract cover page containing the signatures of the Purchasing Division, Attorney General, and Encumbrance clerk (or another page identified as _____), and continues until the project for which the vendor is providing oversight is complete.

Other: Contract Term specified in _____

4. AUTHORITY TO PROCEED: Vendor is authorized to begin performance of this contract on the date of encumbrance listed on the front page of the Award Document unless either the box for "Fixed Period Contract" or "Fixed Period Contract with Renewals" has been checked in Section 3 above. If either "Fixed Period Contract" or "Fixed Period Contract with Renewals" has been checked, Vendor must not begin work until it receives a separate notice to proceed from the State. The notice to proceed will then be incorporated into the Contract via change order to memorialize the official date that work commenced.

5. QUANTITIES: The quantities required under this Contract shall be determined in accordance with the category that has been identified as applicable to this Contract below.

Open End Contract: Quantities listed in this Solicitation/Award Document are approximations only, based on estimates supplied by the Agency. It is understood and agreed that the Contract shall cover the quantities actually ordered for delivery during the term of the Contract, whether more or less than the quantities shown.

Service: The scope of the service to be provided will be more clearly defined in the specifications included herewith.

Combined Service and Goods: The scope of the service and deliverable goods to be provided will be more clearly defined in the specifications included herewith.

One-Time Purchase: This Contract is for the purchase of a set quantity of goods that are identified in the specifications included herewith. Once those items have been delivered, no additional goods may be procured under this Contract without an appropriate change order approved by the Vendor, Agency, Purchasing Division, and Attorney General's office.

Construction: This Contract is for construction activity more fully defined in the specifications.

6. EMERGENCY PURCHASES: The Purchasing Division Director may authorize the Agency to purchase goods or services in the open market that Vendor would otherwise provide under this Contract if those goods or services are for immediate or expedited delivery in an emergency. Emergencies shall include, but are not limited to, delays in transportation or an unanticipated increase in the volume of work. An emergency purchase in the open market, approved by the Purchasing Division Director, shall not constitute of breach of this Contract and shall not entitle the Vendor to any form of compensation or damages. This provision does not excuse the State from fulfilling its obligations under a One-Time Purchase contract.

7. REQUIRED DOCUMENTS: All of the items checked in this section must be provided to the Purchasing Division by the Vendor as specified:

LICENSE(S) / CERTIFICATIONS / PERMITS: In addition to anything required under the Section of the General Terms and Conditions entitled Licensing, the apparent successful Vendor shall furnish proof of the following licenses, certifications, and/or permits upon request and in a form acceptable to the State. The request may be prior to or after contract award at the State's sole discretion.

The apparent successful Vendor shall also furnish proof of any additional licenses or certifications contained in the specifications regardless of whether or not that requirement is listed above.

8. INSURANCE: The apparent successful Vendor shall furnish proof of the insurance identified by a checkmark below prior to Contract award. The insurance coverages identified below must be maintained throughout the life of this contract. Thirty (30) days prior to the expiration of the insurance policies, Vendor shall provide the Agency with proof that the insurance mandated herein has been continued. Vendor must also provide Agency with immediate notice of any changes in its insurance policies, including but not limited to, policy cancelation, policy reduction, or change in insurers. The apparent successful Vendor shall also furnish proof of any additional insurance requirements contained in the specifications prior to Contract award regardless of whether that insurance requirement is listed in this section.

Vendor must maintain:

Commercial General Liability Insurance in at least an amount of: \$1,000,000 per occurrence.

Automobile Liability Insurance in at least an amount of: \$500,000 per occurrence.

Professional/Malpractice/Errors and Omission Insurance in at least an amount of: _____ per occurrence. Notwithstanding the forgoing, Vendor's are not required to list the State as an additional insured for this type of policy.

Commercial Crime and Third Party Fidelity Insurance in an amount of: _____ per occurrence.

Cyber Liability Insurance in an amount of: _____ per occurrence.

Builders Risk Insurance in an amount equal to 100% of the amount of the Contract.

Pollution Insurance in an amount of: _____ per occurrence.

Aircraft Liability in an amount of: _____ per occurrence.

9. WORKERS' COMPENSATION INSURANCE: Vendor shall comply with laws relating to workers compensation, shall maintain workers' compensation insurance when required, and shall furnish proof of workers' compensation insurance upon request.

10. VENUE: All legal actions for damages brought by Vendor against the State shall be brought in the West Virginia Claims Commission. Other causes of action must be brought in the West Virginia court authorized by statute to exercise jurisdiction over it.

11. LIQUIDATED DAMAGES: This clause shall in no way be considered exclusive and shall not limit the State or Agency's right to pursue any other available remedy. Vendor shall pay liquidated damages in the amount specified below or as described in the specifications:

\$250 per day _____ for Each calendar day beyond the end of the contract period .

Liquidated Damages Contained in the Specifications.

Liquidated Damages Are Not Included in this Contract.

12. ACCEPTANCE: Vendor's signature on its bid, or on the certification and signature page, constitutes an offer to the State that cannot be unilaterally withdrawn, signifies that the product or service proposed by vendor meets the mandatory requirements contained in the Solicitation for that product or service, unless otherwise indicated, and signifies acceptance of the terms and conditions contained in the Solicitation unless otherwise indicated.

13. PRICING: The pricing set forth herein is firm for the life of the Contract, unless specified elsewhere within this Solicitation/Contract by the State. A Vendor's inclusion of price adjustment provisions in its bid, without an express authorization from the State in the Solicitation to do so, may result in bid disqualification. Notwithstanding the foregoing, Vendor must extend any publicly advertised sale price to the State and invoice at the lower of the contract price or the publicly advertised sale price.

14. PAYMENT IN ARREARS: Payments for goods/services will be made in arrears only upon receipt of a proper invoice, detailing the goods/services provided or receipt of the goods/services, whichever is later. Notwithstanding the foregoing, payments for software maintenance, licenses, or subscriptions may be paid annually in advance.

15. PAYMENT METHODS: Vendor must accept payment by electronic funds transfer and P-Card. (The State of West Virginia's Purchasing Card program, administered under contract by a banking institution, processes payment for goods and services through state designated credit cards.)

16. TAXES: The Vendor shall pay any applicable sales, use, personal property or any other taxes arising out of this Contract and the transactions contemplated thereby. The State of West Virginia is exempt from federal and state taxes and will not pay or reimburse such taxes.

17. ADDITIONAL FEES: Vendor is not permitted to charge additional fees or assess additional charges that were not either expressly provided for in the solicitation published by the State of West Virginia, included in the Contract, or included in the unit price or lump sum bid amount that Vendor is required by the solicitation to provide. Including such fees or charges as notes to the solicitation may result in rejection of vendor's bid. Requesting such fees or charges be paid after the contract has been awarded may result in cancellation of the contract.

18. FUNDING: This Contract shall continue for the term stated herein, contingent upon funds being appropriated by the Legislature or otherwise being made available. In the event funds are not appropriated or otherwise made available, this Contract becomes void and of no effect beginning on July 1 of the fiscal year for which funding has not been appropriated or otherwise made available. If that occurs, the State may notify the Vendor that an alternative source of funding has been obtained and thereby avoid the automatic termination. Non-appropriation or non-funding shall not be considered an event of default.

19. CANCELLATION: The Purchasing Division Director reserves the right to cancel this Contract immediately upon written notice to the vendor if the materials or workmanship supplied do not conform to the specifications contained in the Contract. The Purchasing Division Director may also cancel any purchase or Contract upon 30 days written notice to the Vendor in accordance with West Virginia Code of State Rules § 148-1-5.2.b.

20. TIME: Time is of the essence regarding all matters of time and performance in this Contract.

21. APPLICABLE LAW: This Contract is governed by and interpreted under West Virginia law without giving effect to its choice of law principles. Any information provided in specification manuals, or any other source, verbal or written, which contradicts or violates the West Virginia Constitution, West Virginia Code, or West Virginia Code of State Rules is void and of no effect.

22. COMPLIANCE WITH LAWS: Vendor shall comply with all applicable federal, state, and local laws, regulations and ordinances. By submitting a bid, Vendor acknowledges that it has reviewed, understands, and will comply with all applicable laws, regulations, and ordinances.

SUBCONTRACTOR COMPLIANCE: Vendor shall notify all subcontractors providing commodities or services related to this Contract that as subcontractors, they too are required to comply with all applicable laws, regulations, and ordinances. Notification under this provision must occur prior to the performance of any work under the contract by the subcontractor.

23. ARBITRATION: Any references made to arbitration contained in this Contract, Vendor's bid, or in any American Institute of Architects documents pertaining to this Contract are hereby deleted, void, and of no effect.

24. MODIFICATIONS: This writing is the parties' final expression of intent. Notwithstanding anything contained in this Contract to the contrary no modification of this Contract shall be binding without mutual written consent of the Agency, and the Vendor, with approval of the Purchasing Division and the Attorney General's office (Attorney General approval is as to form only). Any change to existing contracts that adds work or changes contract cost, and were not included in the original contract, must be approved by the Purchasing Division and the Attorney General's Office (as to form) prior to the implementation of the change or commencement of work affected by the change.

25. WAIVER: The failure of either party to insist upon a strict performance of any of the terms or provision of this Contract, or to exercise any option, right, or remedy herein contained, shall not be construed as a waiver or a relinquishment for the future of such term, provision, option, right, or remedy, but the same shall continue in full force and effect. Any waiver must be expressly stated in writing and signed by the waiving party.

26. SUBSEQUENT FORMS: The terms and conditions contained in this Contract shall supersede any and all subsequent terms and conditions which may appear on any form documents submitted by Vendor to the Agency or Purchasing Division such as price lists, order forms, invoices, sales agreements, or maintenance agreements, and includes internet websites or other electronic documents. Acceptance or use of Vendor's forms does not constitute acceptance of the terms and conditions contained thereon.

27. ASSIGNMENT: Neither this Contract nor any monies due, or to become due hereunder, may be assigned by the Vendor without the express written consent of the Agency, the Purchasing Division, the Attorney General's office (as to form only), and any other government agency or office that may be required to approve such assignments.

28. WARRANTY: The Vendor expressly warrants that the goods and/or services covered by this Contract will: (a) conform to the specifications, drawings, samples, or other description furnished or specified by the Agency; (b) be merchantable and fit for the purpose intended; and (c) be free from defect in material and workmanship.

29. STATE EMPLOYEES: State employees are not permitted to utilize this Contract for personal use and the Vendor is prohibited from permitting or facilitating the same.

30. PRIVACY, SECURITY, AND CONFIDENTIALITY: The Vendor agrees that it will not disclose to anyone, directly or indirectly, any such personally identifiable information or other confidential information gained from the Agency, unless the individual who is the subject of the information consents to the disclosure in writing or the disclosure is made pursuant to the Agency's policies, procedures, and rules. Vendor further agrees to comply with the Confidentiality Policies and Information Security Accountability Requirements, set forth in <http://www.state.wv.us/admin/purchase/privacy/default.html>.

31. YOUR SUBMISSION IS A PUBLIC DOCUMENT: Vendor's entire response to the Solicitation and the resulting Contract are public documents. As public documents, they will be disclosed to the public following the bid/proposal opening or award of the contract, as required by the competitive bidding laws of West Virginia Code §§ 5A-3-1 et seq., 5-22-1 et seq., and 5G-1-1 et seq. and the Freedom of Information Act West Virginia Code §§ 29B-1-1 et seq.

DO NOT SUBMIT MATERIAL YOU CONSIDER TO BE CONFIDENTIAL, A TRADE SECRET, OR OTHERWISE NOT SUBJECT TO PUBLIC DISCLOSURE.

Submission of any bid, proposal, or other document to the Purchasing Division constitutes your explicit consent to the subsequent public disclosure of the bid, proposal, or document. The Purchasing Division will disclose any document labeled "confidential," "proprietary," "trade secret," "private," or labeled with any other claim against public disclosure of the documents, to include any "trade secrets" as defined by West Virginia Code § 47-22-1 et seq. All submissions are subject to public disclosure without notice.

32. LICENSING: In accordance with West Virginia Code of State Rules § 148-1-6.1.e, Vendor must be licensed and in good standing in accordance with any and all state and local laws and requirements by any state or local agency of West Virginia, including, but not limited to, the West Virginia Secretary of State's Office, the West Virginia Tax Department, West Virginia Insurance Commission, or any other state agency or political subdivision. Obligations related to political subdivisions may include, but are not limited to, business licensing, business and occupation taxes, inspection compliance, permitting, etc. Upon request, the Vendor must provide all necessary releases to obtain information to enable the Purchasing Division Director or the Agency to verify that the Vendor is licensed and in good standing with the above entities.

SUBCONTRACTOR COMPLIANCE: Vendor shall notify all subcontractors providing commodities or services related to this Contract that as subcontractors, they too are required to be licensed, in good standing, and up-to-date on all state and local obligations as described in this section. Obligations related to political subdivisions may include, but are not limited to, business licensing, business and occupation taxes, inspection compliance, permitting, etc. Notification under this provision must occur prior to the performance of any work under the contract by the subcontractor.

33. ANTITRUST: In submitting a bid to, signing a contract with, or accepting a Award Document from any agency of the State of West Virginia, the Vendor agrees to convey, sell, assign, or transfer to the State of West Virginia all rights, title, and interest in and to all causes of action it may now or hereafter acquire under the antitrust laws of the United States and the State of West Virginia for price fixing and/or unreasonable restraints of trade relating to the particular commodities or services purchased or acquired by the State of West Virginia. Such assignment shall be made and become effective at the time the purchasing agency tenders the initial payment to Vendor.

34. VENDOR NON-CONFLICT: Neither Vendor nor its representatives are permitted to have any interest, nor shall they acquire any interest, direct or indirect, which would compromise the performance of its services hereunder. Any such interests shall be promptly presented in detail to the Agency.

Revised 11/1/2022

35. VENDOR RELATIONSHIP: The relationship of the Vendor to the State shall be that of an independent contractor and no principal-agent relationship or employer-employee relationship is contemplated or created by this Contract. The Vendor as an independent contractor is solely liable for the acts and omissions of its employees and agents. Vendor shall be responsible for selecting, supervising, and compensating any and all individuals employed pursuant to the terms of this Solicitation and resulting contract. Neither the Vendor, nor any employees or subcontractors of the Vendor, shall be deemed to be employees of the State for any purpose whatsoever. Vendor shall be exclusively responsible for payment of employees and contractors for all wages and salaries, taxes, withholding payments, penalties, fees, fringe benefits, professional liability insurance premiums, contributions to insurance and pension, or other deferred compensation plans, including but not limited to, Workers' Compensation and Social Security obligations, licensing fees, etc. and the filing of all necessary documents, forms, and returns pertinent to all of the foregoing.

Vendor shall hold harmless the State, and shall provide the State and Agency with a defense against any and all claims including, but not limited to, the foregoing payments, withholdings, contributions, taxes, Social Security taxes, and employer income tax returns.

36. INDEMNIFICATION: The Vendor agrees to indemnify, defend, and hold harmless the State and the Agency, their officers, and employees from and against: (1) Any claims or losses for services rendered by any subcontractor, person, or firm performing or supplying services, materials, or supplies in connection with the performance of the Contract; (2) Any claims or losses resulting to any person or entity injured or damaged by the Vendor, its officers, employees, or subcontractors by the publication, translation, reproduction, delivery, performance, use, or disposition of any data used under the Contract in a manner not authorized by the Contract, or by Federal or State statutes or regulations; and (3) Any failure of the Vendor, its officers, employees, or subcontractors to observe State and Federal laws including, but not limited to, labor and wage and hour laws.

37. NO DEBT CERTIFICATION: In accordance with West Virginia Code §§ 5A-3-10a and 5-22-1(i), the State is prohibited from awarding a contract to any bidder that owes a debt to the State or a political subdivision of the State. By submitting a bid, or entering into a contract with the State, Vendor is affirming that (1) for construction contracts, the Vendor is not in default on any monetary obligation owed to the state or a political subdivision of the state, and (2) for all other contracts, neither the Vendor nor any related party owe a debt as defined above, and neither the Vendor nor any related party are in employer default as defined in the statute cited above unless the debt or employer default is permitted under the statute.

38. CONFLICT OF INTEREST: Vendor, its officers or members or employees, shall not presently have or acquire an interest, direct or indirect, which would conflict with or compromise the performance of its obligations hereunder. Vendor shall periodically inquire of its officers, members and employees to ensure that a conflict of interest does not arise. Any conflict of interest discovered shall be promptly presented in detail to the Agency.

39. REPORTS: Vendor shall provide the Agency and/or the Purchasing Division with the following reports identified by a checked box below:

Such reports as the Agency and/or the Purchasing Division may request. Requested reports may include, but are not limited to, quantities purchased, agencies utilizing the contract, total contract expenditures by agency, etc.

Quarterly reports detailing the total quantity of purchases in units and dollars, along with a listing of purchases by agency. Quarterly reports should be delivered to the Purchasing Division via email at purchasing.division@wv.gov.

40. BACKGROUND CHECK: In accordance with W. Va. Code § 15-2D-3, the State reserves the right to prohibit a service provider's employees from accessing sensitive or critical information or to be present at the Capitol complex based upon results addressed from a criminal background check. Service providers should contact the West Virginia Division of Protective Services by phone at (304) 558-9911 for more information.

41. PREFERENCE FOR USE OF DOMESTIC STEEL PRODUCTS: Except when authorized by the Director of the Purchasing Division pursuant to W. Va. Code § 5A-3-56, no contractor may use or supply steel products for a State Contract Project other than those steel products made in the United States. A contractor who uses steel products in violation of this section may be subject to civil penalties pursuant to W. Va. Code § 5A-3-56. As used in this section:

- a. "State Contract Project" means any erection or construction of, or any addition to, alteration of or other improvement to any building or structure, including, but not limited to, roads or highways, or the installation of any heating or cooling or ventilating plants or other equipment, or the supply of and materials for such projects, pursuant to a contract with the State of West Virginia for which bids were solicited on or after June 6, 2001.
- b. "Steel Products" means products rolled, formed, shaped, drawn, extruded, forged, cast, fabricated or otherwise similarly processed, or processed by a combination of two or more or such operations, from steel made by the open heath, basic oxygen, electric furnace, Bessemer or other steel making process.
- c. The Purchasing Division Director may, in writing, authorize the use of foreign steel products if:
 1. The cost for each contract item used does not exceed one tenth of one percent (.1%) of the total contract cost or two thousand five hundred dollars (\$2,500.00), whichever is greater. For the purposes of this section, the cost is the value of the steel product as delivered to the project; or
 2. The Director of the Purchasing Division determines that specified steel materials are not produced in the United States in sufficient quantity or otherwise are not reasonably available to meet contract requirements.

42. PREFERENCE FOR USE OF DOMESTIC ALUMINUM, GLASS, AND STEEL: In Accordance with W. Va. Code § 5-19-1 et seq., and W. Va. CSR § 148-10-1 et seq., for every contract or subcontract, subject to the limitations contained herein, for the construction, reconstruction, alteration, repair, improvement or maintenance of public works or for the purchase of any item of machinery or equipment to be used at sites of public works, only domestic aluminum, glass or steel products shall be supplied unless the spending officer determines, in writing, after the receipt of offers or bids, (1) that the cost of domestic aluminum, glass or steel products is unreasonable or inconsistent with the public interest of the State of West Virginia, (2) that domestic aluminum, glass or steel products are not produced in sufficient quantities to meet the contract requirements, or (3) the available domestic aluminum, glass, or steel do not meet the contract specifications. This provision only applies to public works contracts awarded in an amount more than fifty thousand dollars (\$50,000) or public works contracts that require more than ten thousand pounds of steel products.

The cost of domestic aluminum, glass, or steel products may be unreasonable if the cost is more than twenty percent (20%) of the bid or offered price for foreign made aluminum, glass, or steel products. If the domestic aluminum, glass or steel products to be supplied or produced in a “substantial labor surplus area”, as defined by the United States Department of Labor, the cost of domestic aluminum, glass, or steel products may be unreasonable if the cost is more than thirty percent (30%) of the bid or offered price for foreign made aluminum, glass, or steel products. This preference shall be applied to an item of machinery or equipment, as indicated above, when the item is a single unit of equipment or machinery manufactured primarily of aluminum, glass or steel, is part of a public works contract and has the sole purpose or of being a permanent part of a single public works project. This provision does not apply to equipment or machinery purchased by a spending unit for use by that spending unit and not as part of a single public works project.

All bids and offers including domestic aluminum, glass or steel products that exceed bid or offer prices including foreign aluminum, glass or steel products after application of the preferences provided in this provision may be reduced to a price equal to or lower than the lowest bid or offer price for foreign aluminum, glass or steel products plus the applicable preference. If the reduced bid or offer prices are made in writing and supersede the prior bid or offer prices, all bids or offers, including the reduced bid or offer prices, will be reevaluated in accordance with this rule.

43. INTERESTED PARTY SUPPLEMENTAL DISCLOSURE: W. Va. Code § 6D-1-2 requires that for contracts with an actual or estimated value of at least \$1 million, the Vendor must submit to the Agency a disclosure of interested parties prior to beginning work under this Contract. Additionally, the Vendor must submit a supplemental disclosure of interested parties reflecting any new or differing interested parties to the contract, which were not included in the original pre-work interested party disclosure, within 30 days following the completion or termination of the contract. A copy of that form is included with this solicitation or can be obtained from the WV Ethics Commission. This requirement does not apply to publicly traded companies listed on a national or international stock exchange. A more detailed definition of interested parties can be obtained from the form referenced above.

44. PROHIBITION AGAINST USED OR REFURBISHED: Unless expressly permitted in the solicitation published by the State, Vendor must provide new, unused commodities, and is prohibited from supplying used or refurbished commodities, in fulfilling its responsibilities under this Contract.

45. VOID CONTRACT CLAUSES: This Contract is subject to the provisions of West Virginia Code § 5A-3-62, which automatically voids certain contract clauses that violate State law.

46. ISRAEL BOYCOTT: Bidder understands and agrees that, pursuant to W. Va. Code § 5A-3-63, it is prohibited from engaging in a boycott of Israel during the term of this contract.

ADDITIONAL TERMS AND CONDITIONS (Construction Contracts Only)

1. CONTRACTOR'S LICENSE: Until June 15, 2021, West Virginia Code § 21-11-2, and after that date, § 30-42-2, requires that all persons desiring to perform contracting work in this state be licensed. The West Virginia Contractors Licensing Board is empowered to issue the contractor's license. Applications for a contractor's license may be made by contacting the West Virginia Contractor Licensing Board.

The apparent successful Vendor must furnish a copy of its contractor's license prior to the issuance of a contract award document.

2. BONDS: The following bonds must be submitted:

- a. **BID BOND:** Pursuant to the requirements contained in W. Va. Code § 5-22-1(c), All Vendors submitting a bid on a construction project shall furnish a valid bid bond in the amount of five percent (5%) of the total amount of the bid protecting the State of West Virginia. **THE BID BOND MUST BE SUBMITTED WITH THE BID OR VENDOR'S BID WILL BE DISQUALIFIED.**
- b. **PERFORMANCE BOND:** The apparent successful Vendor shall provide a performance bond in the amount of 100% of the contract. The performance bond must be received by the Purchasing Division prior to Contract award. (Attorney General requires use of the State approved bond forms found at: www.state.wv.us/admin/purchase/forms2.html)
- c. **LABOR/MATERIAL PAYMENT BOND:** The apparent successful Vendor shall provide a labor/material payment bond in the amount of 100% of the Contract value. The labor/material payment bond must be delivered to the Purchasing Division prior to Contract award. (Attorney General requires use of the State approved bond forms found at: www.state.wv.us/admin/purchase/forms2.html)
- d. **MAINTENANCE BOND:** The apparent successful Vendor shall provide a two (2) year maintenance bond covering the roofing system if the work impacts an existing roof. The amount of the bond must be equal to the price associated with the percentage of the project impacting the roof. The maintenance bond must be issued and delivered to the Purchasing Division prior to Contract award. (Attorney General requires use of the State approved bond forms found at: www.state.wv.us/admin/purchase/forms2.html)

In lieu of the Bid Bond, the Vendor may provide certified checks, cashier's checks, or irrevocable letters of credit. Any certified check, cashier's check, or irrevocable letter of credit provided in lieu of the bid bond must be of the same amount required of the Bid Bond and delivered with the bid.

3. DRUG-FREE WORKPLACE AFFIDAVIT: W. Va. Code § 21-1D-5 provides that any solicitation for a public improvement contract requires each Vendor that submits a bid for the work to submit an affidavit that the Vendor has a written plan for a drug-free workplace policy. If the affidavit is not submitted with the bid submission, the Purchasing Division shall promptly request by telephone and electronic mail that the low bidder and second low bidder provide the affidavit within one business day of the request. Failure to submit the affidavit within one business day of receiving the request shall result in disqualification of the bid. To comply with this law, Vendor should complete the enclosed drug-free workplace affidavit and submit the same with its bid. Failure to submit the signed and notarized drugfree workplace affidavit or a similar affidavit that fully complies with the requirements of the applicable code, within one business day of being requested to do so shall result in disqualification of Vendor's bid. Pursuant to W. Va. Code 21-1D-2(b) and (k), this provision does not apply to public improvement contracts the value of which is \$100,000 or less or temporary or emergency repairs.

3.1. DRUG-FREE WORKPLACE POLICY: Pursuant to W. Va. Code § 21-1D-4, Vendor and its subcontractors must implement and maintain a written drug-free workplace policy that complies with said article. The awarding public authority shall cancel this contract if: (1) Vendor fails to implement and maintain a written drug-free workplace policy described in the preceding paragraph, (2) Vendor fails to provide information regarding implementation of its drug-free workplace policy at the request of the public authority; or (3) Vendor provides to the public authority false information regarding the contractor's drug-free workplace policy.

Pursuant to W. Va. Code 21-1D-2(b) and (k), this provision does not apply to public improvement contracts the value of which is \$100,000 or less or temporary or emergency repairs.

4. DRUG FREE WORKPLACE REPORT: Pursuant to W. Va. Code § 21-1D-7b, no less than once per year, or upon completion of the project, every contractor shall provide a certified report to the public authority which let the contract. For contracts over \$25,000, the public authority shall be the West Virginia Purchasing Division. For contracts of \$25,000 or less, the public authority shall be the agency issuing the contract. The report shall include:

- (1) Information to show that the education and training service to the requirements of West Virginia Code § 21-1D-5 was provided;
- (2) The name of the laboratory certified by the United States Department of Health and Human Services or its successor that performs the drug tests;
- (3) The average number of employees in connection with the construction on the public improvement;
- (4) Drug test results for the following categories including the number of positive tests and the number of negative tests: (A) Pre-employment and new hires; (B) Reasonable suspicion; (C) Post-accident; and (D) Random.

Vendor should utilize the attached Certified Drug Free Workplace Report Coversheet when submitting the report required hereunder. Pursuant to W. Va. Code 21-1D-2(b) and (k), this provision does not apply to public improvement contracts the value of which is \$100,000 or less or temporary or emergency repairs.

5. AIA DOCUMENTS: All construction contracts that will be completed in conjunction with architectural services procured under Chapter 5G of the West Virginia Code will be governed by the attached AIA documents, as amended by the Supplementary Conditions for the State of West Virginia, in addition to the terms and conditions contained herein.

6. PROHIBITION AGAINST GENERAL CONDITIONS: Notwithstanding anything contained in the AIA Documents or the Supplementary Conditions, the State of West Virginia will not pay for general conditions, or winter conditions, or any other condition representing a delay in the contracts. The Vendor is expected to mitigate delay costs to the greatest extent possible and any costs associated with Delays must be specifically and concretely identified. The state will not consider an average daily rate multiplied by the number of days extended to be an acceptable charge.

7. GREEN BUILDINGS MINIMUM ENERGY STANDARDS: In accordance with § 22-29-4, all new building construction projects of public agencies that have not entered the schematic design phase prior to July 1, 2012, or any building construction project receiving state grant funds and appropriations, including public schools, that have not entered the schematic design phase prior to July 1, 2012, shall be designed and constructed complying with the ICC International Energy Conservation Code, adopted by the State Fire Commission, and the ANSI/ASHRAE/IESNA Standard 90.1-2007: Provided, That if any construction project has a commitment of federal funds to pay for a portion of such project, this provision shall only apply to the extent such standards are consistent with the federal standards.

8. LOCAL LABOR MARKET HIRING REQUIREMENT: Pursuant to West Virginia Code §21-1C-1 et seq., Employers shall hire at least seventy-five percent of employees for public improvement construction projects from the local labor market, to be rounded off, with at least two employees from outside the local labor market permissible for each employer per project.

Any employer unable to employ the minimum number of employees from the local labor market shall inform the nearest office of Workforce West Virginia of the number of qualified employees needed and provide a job description of the positions to be filled.

If, within three business days following the placing of a job order, Workforce West Virginia is unable to refer any qualified job applicants to the employer or refers less qualified job applicants than the number requested, then Workforce West Virginia shall issue a waiver to the employer stating the unavailability of applicant and shall permit the employer to fill any positions covered by the waiver from outside the local labor market. The waiver shall be in writing and shall be issued within the prescribed three days. A waiver certificate shall be sent to both the employer for its permanent project records and to the public authority.

Any employer who violates this requirement is subject to a civil penalty of \$250 per each employee less than the required threshold of seventy-five percent per day of violation after receipt of a notice of violation.

Any employer that continues to violate any provision of this article more than fourteen calendar days after receipt of a notice of violation is subject to a civil penalty of \$500 per each employee less than the required threshold of seventy-five percent per day of violation.

The following terms used in this section have the meaning shown below.

(1) The term “construction project” means any construction, reconstruction, improvement, enlargement, painting, decorating or repair of any public improvement let to contract in an amount equal to or greater than \$500,000. The term “construction project” does not include temporary or emergency repairs;

(2) The term “employee” means any person hired or permitted to perform hourly work for wages by a person, firm or corporation in the construction industry; The term “employee” does not include:(i) Bona fide employees of a public authority or individuals engaged in making temporary or emergency repairs;(ii) Bona fide independent contractors; or(iii) Salaried supervisory personnel necessary to assure efficient execution of the employee's work;

(3) The term “employer” means any person, firm or corporation employing one or more employees on any public improvement and includes all contractors and subcontractors;

(4) The term “local labor market” means every county in West Virginia and any county outside of West Virginia if any portion of that county is within fifty miles of the border of West Virginia;

(5) The term “public improvement” includes the construction of all buildings, roads, highways, bridges, streets, alleys, sewers, ditches, sewage disposal plants, waterworks, airports and all other structures that may be let to contract by a public authority, excluding improvements funded, in whole or in part, by federal funds.

9. DAVIS-BACON AND RELATED ACT WAGE RATES:

The work performed under this contract is federally funded in whole, or in part. Pursuant to _____, Vendors are required to pay applicable Davis-Bacon wage rates.

The work performed under this contract is not subject to Davis-Bacon wage rates.

10. SUBCONTRACTOR LIST SUBMISSION: In accordance with W. Va. Code § 5-22-1, the apparent low bidder on a contract valued at more than \$250,000.00 for the construction, alteration, decoration, painting or improvement of a new or existing building or structure shall submit a list of all subcontractors who will perform more than \$25,000.00 of work on the project including labor and materials. (This section does not apply to any other construction projects, such as highway, mine reclamation, water or sewer projects.) The subcontractor list shall be provided to the Purchasing Division within one business day of the opening of bids for review. If the apparent low bidder fails to submit the subcontractor list, the Purchasing Division shall promptly request by telephone and electronic mail that the low bidder and second low bidder provide the subcontractor list within one business day of the request. Failure to submit the subcontractor list within one business day of receiving the request shall result in disqualification of the bid.

If no subcontractors who will perform more than \$25,000.00 of work are to be used to complete the project, the apparent low bidder must make this clear on the subcontractor list, in the bid itself, or in response to the Purchasing Division's request for the subcontractor list.

a. Required Information. The subcontractor list must contain the following information:

i. Bidder's name

ii. Name of each subcontractor performing more than \$25,000 of work on the project.

iii. The license number of each subcontractor, as required by W. Va. Code § 21-11-1 et. seq.

iv. If applicable, a notation that no subcontractor will be used to perform more than \$25,000.00 of work. (This item iv. is not required if the vendor makes this clear in the bid itself or in documentation following the request for the subcontractor list.)

b. Subcontractor List Submission Form: The subcontractor list may be submitted in any form, including the attached form, as long as the required information noted above is included. If any information is missing from the bidder's subcontractor list submission, it may be obtained from other documents such as bids, emails, letters, etc. that accompany the subcontractor list submission.

c. Substitution of Subcontractor. Written approval must be obtained from the State Spending Unit before any subcontractor substitution is permitted. Substitutions are not permitted unless:

i. The subcontractor listed in the original bid has filed for bankruptcy;

ii. The subcontractor in the original bid has been debarred or suspended; or

iii. The contractor certifies in writing that the subcontractor listed in the original bid fails, is unable, or refuses to perform his subcontract.

Subcontractor List Submission (Construction Contracts Only)

Bidder's Name: ALL-Pumps Sales + Service, INC.

Check this box if no subcontractors will perform more than \$25,000.00 of work to complete the project.

Subcontractor Name	License Number if Required by W. Va. Code § 21-11-1 et. seq.

Attach additional pages if necessary

DESIGNATED CONTACT: Vendor appoints the individual identified in this Section as the Contract Administrator and the initial point of contact for matters relating to this Contract.

(Printed Name and Title) Tom Fellure President
(Address) 2182 Rt 75 Herndon WV 25530
(Phone Number) / (Fax Number) 304-453-5610 304-453-564
(Email address) tfellure,rspe@zoominternet.net

CERTIFICATION AND SIGNATURE: By signing below, or submitting documentation through wvOASIS, I certify that: I have reviewed this Solicitation/Contract in its entirety; that I understand the requirements, terms and conditions, and other information contained herein; that this bid, offer or proposal constitutes an offer to the State that cannot be unilaterally withdrawn; that the product or service proposed meets the mandatory requirements contained in the Solicitation/Contract for that product or service, unless otherwise stated herein; that the Vendor accepts the terms and conditions contained in the Solicitation, unless otherwise stated herein; that I am submitting this bid, offer or proposal for review and consideration; that this bid or offer was made without prior understanding, agreement, or connection with any entity submitting a bid or offer for the same material, supplies, equipment or services; that this bid or offer is in all respects fair and without collusion or fraud; that this Contract is accepted or entered into without any prior understanding, agreement, or connection to any other entity that could be considered a violation of law; that I am authorized by the Vendor to execute and submit this bid, offer, or proposal, or any documents related thereto on Vendor's behalf; that I am authorized to bind the vendor in a contractual relationship; and that to the best of my knowledge, the vendor has properly registered with any State agency that may require registration.

By signing below, I further certify that I understand this Contract is subject to the provisions of West Virginia Code § 5A-3-62, which automatically voids certain contract clauses that violate State law; and that pursuant to W. Va. Code 5A-3-63, the entity entering into this contract is prohibited from engaging in a boycott against Israel.

ALL Pumps Saks + Service, INC.
(Company)
Thomas G Fellure
(Signature of Authorized Representative)
Thomas G Fellure President 10/4/23
(Printed Name and Title of Authorized Representative) (Date)
304-453-5610 304-453-5640
(Phone Number) (Fax Number)
tfellure,rspe@zoominternet.net
(Email Address)

REQUEST FOR QUOTATION
WVDNR
Hawks Nest State Park
Sewage Lift Station Replacement

GENERAL CONSTRUCTION SPECIFICATIONS

1. **PURPOSE AND SCOPE:** The West Virginia Purchasing Division is soliciting bids on behalf of the Division of Natural Resources to establish a contract for construction of replacement of the wastewater lift station at Hawks Nest State Park in Ansted, West Virginia.

2. **DEFINITIONS:** The terms listed below shall have the meanings assigned to them below. Additional definitions can be found in section 2 of the General Terms and Conditions and in the Specification's Manual as defined below.
 - 2.1 **"Construction Services"** means construction of a new wastewater lift station while maintaining the current operational function of the existing wastewater lift station. The project also includes other incidental construction as more fully described in these specifications and the Specifications/Project Manual.

 - 2.2 **"Pricing Page"** means the pages contained in wvOASIS, attached hereto, or included in the Specifications/Project Manual upon which Vendor should list its proposed price for the Construction Services.

 - 2.3 **"Solicitation"** means the official notice of an opportunity to supply the State with Construction Services that is published by the Purchasing Division.

 - 2.4 **"Specifications/Project Manual"** means the American Institute of Architect forms, specifications, plans, drawings, and related documents developed by the architect, engineer, or Agency that provide detailed instructions on how the Construction Services are to be performed along with any American Institute of Architects documents ("AIA documents") attached thereto.

3. **ORDER OF PRECEDENCE:** This General Construction Specifications document will have priority over, and supersede, anything contained in the Specifications/Project Manual.

4. **QUALIFICATIONS:** Vendor, or Vendor's staff if requirements are inherently limited to individuals rather than corporate entities, shall have the following minimum qualifications:
 - 4.1. **Experience:** Vendor, or Vendor's supervisory staff assigned to this project, must have successfully completed at least [insert number of projects] projects that involved work similar to that described in the Specifications/Project Manual. Compliance with this experience requirement will be determined prior to contract

REQUEST FOR QUOTATION
WVDNR
Hawks Nest State Park
Sewage Lift Station Replacement

award by the State through references provided by the Vendor upon request, through knowledge or documentation of the Vendor's past projects, through confirmation of experience requirements from the architect assisting the State in this project, or some other method that the State determines to be acceptable. Vendor must provide any documentation requested by the State to assist in confirmation of compliance with this provision. References, documentation, or other information to confirm compliance with this experience requirement may be requested after bid opening and prior to contract award.

5. **CONTRACT AWARD:** The Contract is intended to provide Agency with a purchase price for the Construction Services. The Contract will be awarded to the lowest qualified responsible bidder meeting the required specifications. If the Pricing Pages contain alternates/add-ons, the Contract will be awarded based on the grand total of the base bid and any alternates/add-ons selected.
6. **SELECTION OF ALTERNATES:** Pursuant to W. Va. Code § 5-22-1(f), any solicitation of bids shall include no more than five alternates. Alternates, if accepted, shall be accepted in the order in which they are listed on the bid form. Any unaccepted alternate contained within a bid shall expire 90 days after the date of the opening of bids for review. Determination of the lowest qualified responsible bidder shall be based on the sum of the base bid and any alternates accepted. Alternate selection will be identified in the Purchase Order.
7. **PROGRESS PAYMENTS:** The Vendor will be paid in the form of periodic progress payments for work completed. Payment requests along with documentation supporting the request will be submitted to and reviewed by the Architect. If approved, the Architect will communicate approval to the Owner and Owner will process payment. The Owner reserves the right to withhold liquidated damages from progress payments. Progress payments will be made no more than monthly.

Approval and payment of progress payments will be based on Contractor's submission of a payment allocation schedule which allocates the entire contract sum to payment milestones. Architect and Owner will review the payment allocation and may mandate changes that they believe are necessary.
8. **RETAINAGE:** Agency is entitled to withhold ten percent (10%) from each progress payment made as retainage. Agency will partially release retainage upon certification of substantial completion by the Architect in accordance with this Contract but will continue to retain amounts sufficient to cover activities needed to reach final completion.
9. **PERFORMANCE:** Vendor shall perform the Construction Services in accordance with this document and the Specifications/Project Manual.

**REQUEST FOR QUOTATION
WVDNR
Hawks Nest State Park
Sewage Lift Station Replacement**

10. SUBSTANTIAL AND FINAL COMPLETION: Vendor shall achieve substantial completion by [insert date] and final completion by [insert date]. Failure to meet the deadlines established herein, unless extended by change order authorizing additional time free of liquidated damages, will result in liquidated damages being applied.

11. PROJECT PLANS: Copies of the project plans can be obtained by contacting the entity identified below.

Alpha Associates, Inc.
209 Prairie Ave, Suite 209
Morgantown, WV 26501
304-296-8216
Or via email at chuck.branch@thinkalphafirst.com

For a fee of \$100.00 for Paper Plans and Specifications

Copies of project plans can be examined at the following locations:

Contractors Association of West Virginia
2114 Kanawha Boulevard East
Charleston, WV 25311
Phone: 304-342-1166
Fax: 304-342-1074

Kanawha Valley Builders Association
1627 Bigley Avenue
Charleston, WV 25302
Phone: 304-342-7141
Fax: 304-343-8014

Construction Employers Association NCWV
2794 White Hall Blvd
White Hall, WV 26554
Phone: 304-367-1290
Fax: 304-367-0126

Parkersburg Marietta Contractors Association
2905 Emerson Avenue
Parkersburg, WV 26104
Phone: 304-485-6485
Fax: 304-428-7622

REQUEST FOR QUOTATION
WVDNR
Hawks Nest State Park
Sewage Lift Station Replacement

12. SUBSTITUTIONS: Any substitution requests must be submitted in accordance with the official question and answer period described in the INSTRUCTIONS TO VENDORS SUBMITTING BIDS, Paragraph 4. Vendor Question Deadline.

13. FACILITIES ACCESS: Performance of Contract Services may require access cards and/or keys to gain entrance to Agency's facilities. In the event that access cards and/or keys are required:

13.1. Vendor must identify principal service personnel which will be issued access cards and/or keys to perform service.

13.2. Vendor will be responsible for controlling cards and keys and will pay replacement fee, if the cards or keys become lost or stolen.

13.3. Vendor shall notify Agency immediately of any lost, stolen, or missing card or key.

13.4. Anyone performing under this Contract will be subject to Agency's security protocol and procedures.

13.5. Vendor shall inform all staff of Agency's security protocol and procedures.

14. MISCELLANEOUS:

14.1. Contract Manager: During its performance of this Contract, Vendor must designate and maintain a primary contract manager responsible for overseeing Vendor's responsibilities under this Contract. The Contract manager must be available during normal business hours to address any customer service or other issues related to this Contract. Vendor should list its Contract manager and his or her contact information below.

Contract Manager: Tom Fellurp

Telephone Number: 304-453-5610

Fax Number: 304-453-5640

Email Address: tfellurp.rspr@zcominternet.net

REQUEST FOR QUOTATION
WVDNR
Hawks Nest State Park
Sewage Lift Station Replacement

14.2. Owner's Representative: Owner's representative for notice purposes is

Name: Donald Bailey, Jr.

Telephone Number: 304-558-2764

Fax Number: _____

Email Address: donald.e.bailey@wv.gov

15. Initial Decision Maker: Richard Colebank, the Architect, shall serve as the Initial Decision Maker in matters relating to this contract.

REQUEST FOR QUOTATION
Hawks Nest State Park
Sewage Lift Station

EXHIBIT A – Pricing Page

Name of Bidder:

ALL- Pumps Sinks + Service, Inc

Address of Bidder:

2182 Rt 75
HARLOW WV 25530

Phone Number of Bidder:

304-453-5610

WV Contractors License No.

WV 059831

We, the undersigned, having examined the site and being familiar with the local conditions affecting the cost of the work and also being familiar with the general conditions to bidders, drawings, and specifications, hereby propose to furnish all materials, equipment, and labor to complete all work in a workmanlike manner, as described in the Bidding Documents.

Base Bid

The Base Bid shall consist of all the work described and specified in the Bidding Documents, Construction Plans, and Project Manual/Construction Specifications as Base Bid.

Total Base Bid:

Lump sum for all labor, materials, and equipment as defined in the Bidding Documents.

Written in numbers.

\$135,000.00

Total Base Bid:

Lump sum for all labor, materials, and equipment as defined in the Bidding Documents.

Written in words.

One Hundred And
Thirty Five Thousand
Dollar and zero cents

The Bidder understands that the successful Bidder will be determined based upon the lowest Base Bid.

Authorized Vendor Signature:

Thomas J. Fellers



State of West Virginia
PURCHASING DIVISION
Construction Bid Submission Review Form

This list has been provided for informational purposes only and is not to be construed as a complete list of request for quotation or bidding requirements for any individual construction project. This list does not and cannot include every item, mistake or oversight that could cause a contractor's bid to be disqualified. Rather, this list is intended to draw attention to some of the most common problems that the Purchasing Division encounters in the bidding process for construction projects. All potential bidders must read the request for quotation, all additional documents, and all instructions relating thereto ("Bid Documents") in their entirety to identify the actual request for quotation and bidding requirements. Failure to read the Bid Documents in their entirety and comply with the stated requirements contained therein may result in bid disqualification.

Errors That Shall Be Reason for Immediate Bid Disqualification

1. Failure to attend a mandatory pre-bid meeting
2. Failure to sign the bid
3. Failure to supply a valid bid bond or other surety approved by the state of West Virginia
4. Failure to meet any mandatory requirement of the solicitation
5. Failure to submit bid prior to the bid opening date and time
6. Federal debarment
7. State of West Virginia debarment or suspension

Errors that May Be Reason for Bid Disqualification Before Contract Award

1. Failure to acknowledge receipt of Addenda (only if stipulated as mandatory)
2. Debt to the state or political subdivision (must be cured prior to award)
3. Workers' Compensation or Unemployment Compensation delinquency (must be cured prior to award)
4. Not registered as a vendor with the state of West Virginia (must be cured prior to award)
5. Failure to obtain required bonds and/or insurance
6. Failure to provide the sub-contractor listing within one business day of bid opening or one business day of the request to do so by the Purchasing Division
7. Failure to supply West Virginia contractor's license number with bid or within one day of Purchasing Division request to do so
8. Failure to supply a signed drug-free workplace affidavit with bid or within one day of Purchasing Division request to do so
9. Failure to use the provided solicitation form (only if stipulated as mandatory)



**State of West Virginia
DRUG FREE WORKPLACE CONFORMANCE AFFIDAVIT
West Virginia Code §21-1D-5**

I, Thomas G Fellner, after being first duly sworn, depose and state as follows:

- 1. I am an employee of ALL-Pumps Saks + Service, Inc. and,
(Company Name)
- 2. I do hereby attest that ALL-Pumps Saks + Service, Inc.
(Company Name)

maintains a written plan for a drug-free workplace policy and that such plan and policy are in compliance with **West Virginia Code §21-1D**.

The above statements are sworn to under the penalty of perjury.

Printed Name: Thomas G Fellner
 Signature: Thomas G Fellner
 Title: President
 Company Name: ALL-Pumps Saks + Service, Inc.
 Date: 10/4/23

STATE OF WEST VIRGINIA,

COUNTY OF Wayne, TO-WIT:

Taken, subscribed and sworn to before me this 4 day of Oct., 2023.

By Commission expires Oct. 28, 2024

(Seal)

Joann Hayton
(Notary Public)

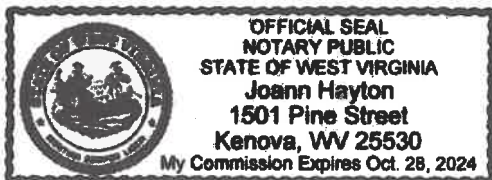



CONTRACTOR LICENSE

AUTHORIZED BY THE
West Virginia Contractor
Licensing Board

NUMBER: **WV059831**

CLASSIFICATION:
GENERAL BUILDING
SPECIALTY

ALL PUMPS SALES & SERVICE INC
DBA ALL PUMPS SALES & SERVICE INC
2182 RT 75
KENOVA, WV 25530

DATE ISSUED

EXPIRATION DATE

JUNE 30, 2023

JUNE 30, 2024

Authorized Signature

Chair, West Virginia Contractor
Licensing Board



A copy of this license must be readily available for inspection by the Board on every job site where contracting work is being performed. This license number must appear in all advertisements, on all bid submissions, and on all fully executed and binding contracts. This license is non-transferable. This license is being issued under the provisions of West Virginia Code, Chapter 30, Article 42.



CERTIFICATE OF LIABILITY INSURANCE

DATE (MM/DD/YYYY)
10/3/2023

THIS CERTIFICATE IS ISSUED AS A MATTER OF INFORMATION ONLY AND CONFERS NO RIGHTS UPON THE CERTIFICATE HOLDER. THIS CERTIFICATE DOES NOT AFFIRMATIVELY OR NEGATIVELY AMEND, EXTEND OR ALTER THE COVERAGE AFFORDED BY THE POLICIES BELOW. THIS CERTIFICATE OF INSURANCE DOES NOT CONSTITUTE A CONTRACT BETWEEN THE ISSUING INSURER(S), AUTHORIZED REPRESENTATIVE OR PRODUCER, AND THE CERTIFICATE HOLDER.

IMPORTANT: If the certificate holder is an ADDITIONAL INSURED, the policy(les) must be endorsed. If SUBROGATION IS WAIVED, subject to the terms and conditions of the policy, certain policies may require an endorsement. A statement on this certificate does not confer rights to the certificate holder in lieu of such endorsement(s).

PRODUCER AssuredPartners of West Virginia, LLC P O Box 2627 Huntington WV 25726		CONTACT NAME: Kim Woods PHONE (A/C No. Ext): (304) 736-2222 E-MAIL ADDRESS: kim.woods@assuredpartners.com FAX (A/C No): (304) 302-3401	
INSURED All Pumps Sales & Service, Inc 2182 Rt 75 Kenova WV 25530		INSURER(S) AFFORDING COVERAGE INSURER A: Motorists Insurance NAIC # 13331 INSURER B: Employers Preferred Insurance Company 10346 INSURER C: INSURER D: INSURER E: INSURER F:	

COVERAGES **CERTIFICATE NUMBER: 22/23 Master** **REVISION NUMBER:**

THIS IS TO CERTIFY THAT THE POLICIES OF INSURANCE LISTED BELOW HAVE BEEN ISSUED TO THE INSURED NAMED ABOVE FOR THE POLICY PERIOD INDICATED. NOTWITHSTANDING ANY REQUIREMENT, TERM OR CONDITION OF ANY CONTRACT OR OTHER DOCUMENT WITH RESPECT TO WHICH THIS CERTIFICATE MAY BE ISSUED OR MAY PERTAIN, THE INSURANCE AFFORDED BY THE POLICIES DESCRIBED HEREIN IS SUBJECT TO ALL THE TERMS, EXCLUSIONS AND CONDITIONS OF SUCH POLICIES. LIMITS SHOWN MAY HAVE BEEN REDUCED BY PAID CLAIMS.

INSR LTR	TYPE OF INSURANCE	ADDL INSD	SUBR WVD	POLICY NUMBER	POLICY EFF (MM/DD/YYYY)	POLICY EXP (MM/DD/YYYY)	LIMITS
A	<input checked="" type="checkbox"/> COMMERCIAL GENERAL LIABILITY <input type="checkbox"/> CLAIMS-MADE <input checked="" type="checkbox"/> OCCUR GEN'L AGGREGATE LIMIT APPLIES PER: <input checked="" type="checkbox"/> POLICY <input type="checkbox"/> PRO-JECT <input type="checkbox"/> LOC OTHER:			5000146277	10/19/2022	10/19/2023	EACH OCCURRENCE \$ 1,000,000 DAMAGE TO RENTED PREMISES (Ea occurrence) \$ 100,000 MED EXP (Any one person) \$ 5,000 PERSONAL & ADV INJURY \$ 1,000,000 GENERAL AGGREGATE \$ 2,000,000 PRODUCTS - COMP/OP AGG \$ 2,000,000
	AUTOMOBILE LIABILITY <input type="checkbox"/> ANY AUTO <input type="checkbox"/> ALL OWNED AUTOS <input type="checkbox"/> SCHEDULED AUTOS <input type="checkbox"/> HIRED AUTOS <input type="checkbox"/> NON-OWNED AUTOS						COMBINED SINGLE LIMIT (Ea accident) \$ BODILY INJURY (Per person) \$ BODILY INJURY (Per accident) \$ PROPERTY DAMAGE (Per accident) \$
A	<input checked="" type="checkbox"/> UMBRELLA LIAB <input checked="" type="checkbox"/> OCCUR <input type="checkbox"/> EXCESS LIAB <input type="checkbox"/> CLAIMS-MADE DED RETENTION \$			5000148767	10/19/2022	10/19/2023	EACH OCCURRENCE \$ 1,000,000 AGGREGATE \$ 1,000,000
B	WORKERS COMPENSATION AND EMPLOYERS' LIABILITY ANY PROPRIETOR/PARTNER/EXECUTIVE OFFICER/MEMBER EXCLUDED? (Mandatory in NH) If yes, describe under DESCRIPTION OF OPERATIONS below		Y/N N/A	EIG4618457	10/19/2022	10/19/2023	<input checked="" type="checkbox"/> PER STATUTE <input type="checkbox"/> OTH-ER E.L. EACH ACCIDENT \$ 1,000,000 E.L. DISEASE - EA EMPLOYEE \$ 1,000,000 E.L. DISEASE - POLICY LIMIT \$ 1,000,000

DESCRIPTION OF OPERATIONS / LOCATIONS / VEHICLES (ACORD 101, Additional Remarks Schedule, may be attached if more space is required)
Evidence of Insurance

CERTIFICATE HOLDER Division of Natural Resources Hawks Nest State Park 9 Hawks Nest Park Road Ansted, WV 25812	CANCELLATION SHOULD ANY OF THE ABOVE DESCRIBED POLICIES BE CANCELLED BEFORE THE EXPIRATION DATE THEREOF, NOTICE WILL BE DELIVERED IN ACCORDANCE WITH THE POLICY PROVISIONS. AUTHORIZED REPRESENTATIVE Kim Woods/KIMWOO <i>Kim Woods</i>
---	---



CERTIFICATE OF LIABILITY INSURANCE

DATE (MM/DD/YYYY)

10/03/2023

THIS CERTIFICATE IS ISSUED AS A MATTER OF INFORMATION ONLY AND CONFERS NO RIGHTS UPON THE CERTIFICATE HOLDER. THIS CERTIFICATE DOES NOT AFFIRMATIVELY OR NEGATIVELY AMEND, EXTEND OR ALTER THE COVERAGE AFFORDED BY THE POLICIES BELOW. THIS CERTIFICATE OF INSURANCE DOES NOT CONSTITUTE A CONTRACT BETWEEN THE ISSUING INSURER(S), AUTHORIZED REPRESENTATIVE OR PRODUCER, AND THE CERTIFICATE HOLDER.

IMPORTANT: If the certificate holder is an ADDITIONAL INSURED, the policy(ies) must have ADDITIONAL INSURED provisions or be endorsed. If SUBROGATION IS WAIVED, subject to the terms and conditions of the policy, certain policies may require an endorsement. A statement on this certificate does not confer rights to the certificate holder in lieu of such endorsement(s).

PRODUCER Highland Insurance Agency 1526 3rd Ave Huntington WV 25701		CONTACT NAME: Sharon Rees PHONE (A/C, No, Ext): (304)529-3381 E-MAIL ADDRESS: srrhighlandins@wvdsi.net		FAX (A/C, No): (304)529-6623	
INSURED All Pumps Sales & Service, Inc 2182 Route 75 Kenova WV 25530-9576		INSURER(S) AFFORDING COVERAGE INSURER A : Erie Insurance Company		NAIC # 26263	
		INSURER B :			
		INSURER C :			
		INSURER D :			
		INSURER E :			
		INSURER F :			

COVERAGES**CERTIFICATE NUMBER:****REVISION NUMBER:**

THIS IS TO CERTIFY THAT THE POLICIES OF INSURANCE LISTED BELOW HAVE BEEN ISSUED TO THE INSURED NAMED ABOVE FOR THE POLICY PERIOD INDICATED. NOTWITHSTANDING ANY REQUIREMENT, TERM OR CONDITION OF ANY CONTRACT OR OTHER DOCUMENT WITH RESPECT TO WHICH THIS CERTIFICATE MAY BE ISSUED OR MAY PERTAIN, THE INSURANCE AFFORDED BY THE POLICIES DESCRIBED HEREIN IS SUBJECT TO ALL THE TERMS, EXCLUSIONS AND CONDITIONS OF SUCH POLICIES. LIMITS SHOWN MAY HAVE BEEN REDUCED BY PAID CLAIMS.

INSR LTR	TYPE OF INSURANCE	ADDL INSD	SUBR WVD	POLICY NUMBER	POLICY EFF (MM/DD/YYYY)	POLICY EXP (MM/DD/YYYY)	LIMITS
	COMMERCIAL GENERAL LIABILITY <input type="checkbox"/> CLAIMS-MADE <input type="checkbox"/> OCCUR GEN'L AGGREGATE LIMIT APPLIES PER. <input type="checkbox"/> POLICY <input type="checkbox"/> PRO-JECT <input type="checkbox"/> LOC OTHER:						EACH OCCURRENCE \$ DAMAGE TO RENTED PREMISES (Ea occurrence) \$ MED EXP (Any one person) \$ PERSONAL & ADV INJURY \$ GENERAL AGGREGATE \$ PRODUCTS - COMP/OP AGG \$ \$
A	AUTOMOBILE LIABILITY <input checked="" type="checkbox"/> ANY AUTO <input type="checkbox"/> OWNED AUTOS ONLY <input type="checkbox"/> HIRED AUTOS ONLY <input type="checkbox"/> SCHEDULED AUTOS <input type="checkbox"/> NON-OWNED AUTOS ONLY			Q016830217	01/18/2023	01/18/2024	COMBINED SINGLE LIMIT (Ea accident) \$ 1,000,000 BODILY INJURY (Per person) \$ BODILY INJURY (Per accident) \$ PROPERTY DAMAGE (Per accident) \$ \$
	UMBRELLA LIAB <input type="checkbox"/> OCCUR EXCESS LIAB <input type="checkbox"/> CLAIMS-MADE DED RETENTION \$						EACH OCCURRENCE \$ AGGREGATE \$ \$
	WORKERS COMPENSATION AND EMPLOYERS' LIABILITY ANY PROPRIETOR/PARTNER/EXECUTIVE OFFICER/MEMBER EXCLUDED? (Mandatory in NH) If yes, describe under DESCRIPTION OF OPERATIONS below						PER STATUTE OTH-ER E.L. EACH ACCIDENT \$ E.L. DISEASE - EA EMPLOYEE \$ E.L. DISEASE - POLICY LIMIT \$

DESCRIPTION OF OPERATIONS / LOCATIONS / VEHICLES (ACORD 101, Additional Remarks Schedule, may be attached if more space is required)

CERTIFICATE HOLDER**CANCELLATION**

Division of Natural Resources
Hawks Nest State Park
49 Hawks Nest Park Road
Ansted, WV 25812

SHOULD ANY OF THE ABOVE DESCRIBED POLICIES BE CANCELLED BEFORE THE EXPIRATION DATE THEREOF, NOTICE WILL BE DELIVERED IN ACCORDANCE WITH THE POLICY PROVISIONS.

AUTHORIZED REPRESENTATIVE

Sharon Rees

Fax:
ACORD 25 (2016/03)

Email:

© 1988-2015 ACORD CORPORATION. All rights reserved.

The ACORD name and logo are registered marks of ACORD

Pumps
To Be
Used in
New
Station

Performance for Keen Pump

Pump Model	1HP PROGRESSIVE CAVITY GRINDER		
Speed	1750 RPM	Discharge	1-1/4"

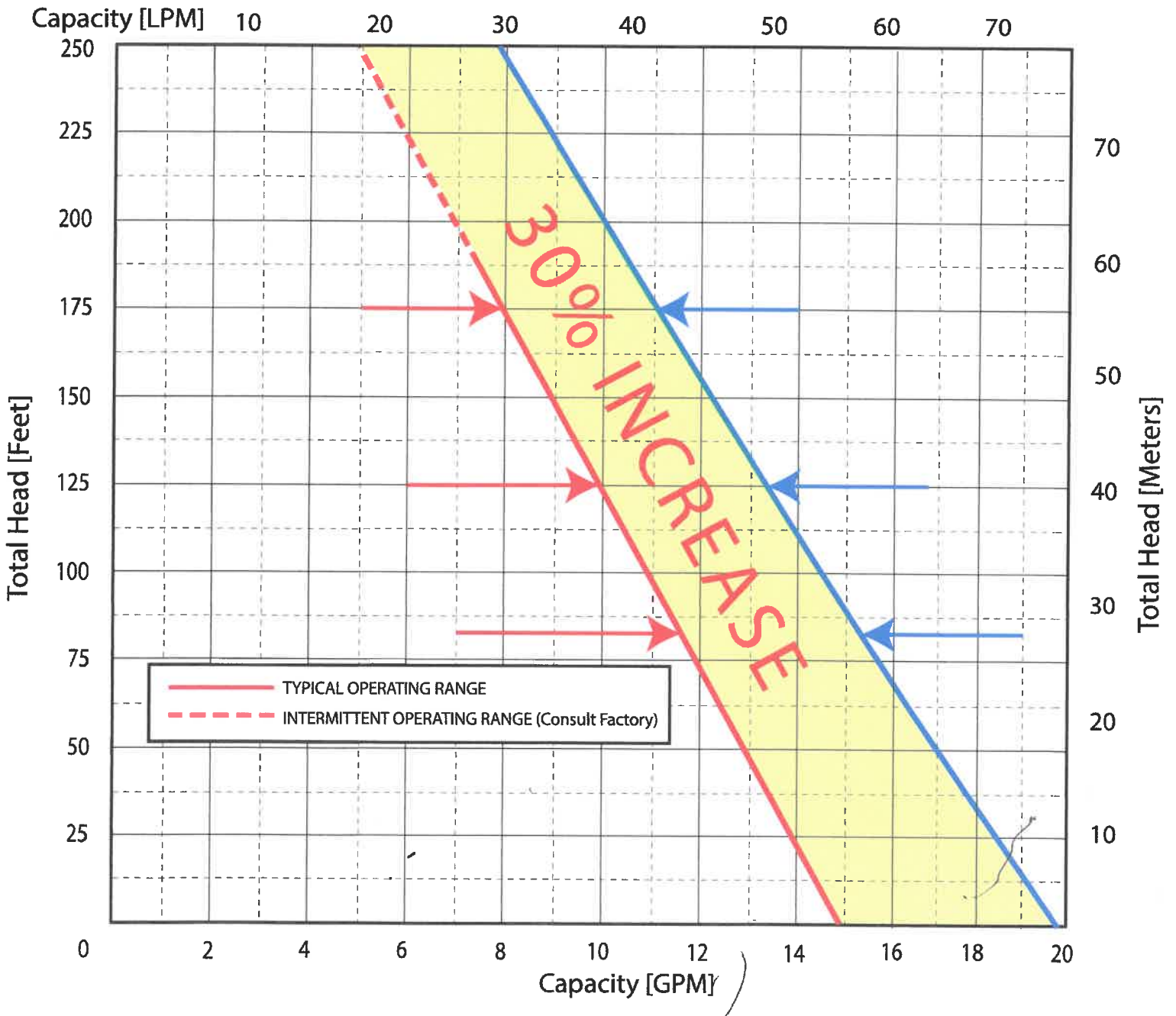

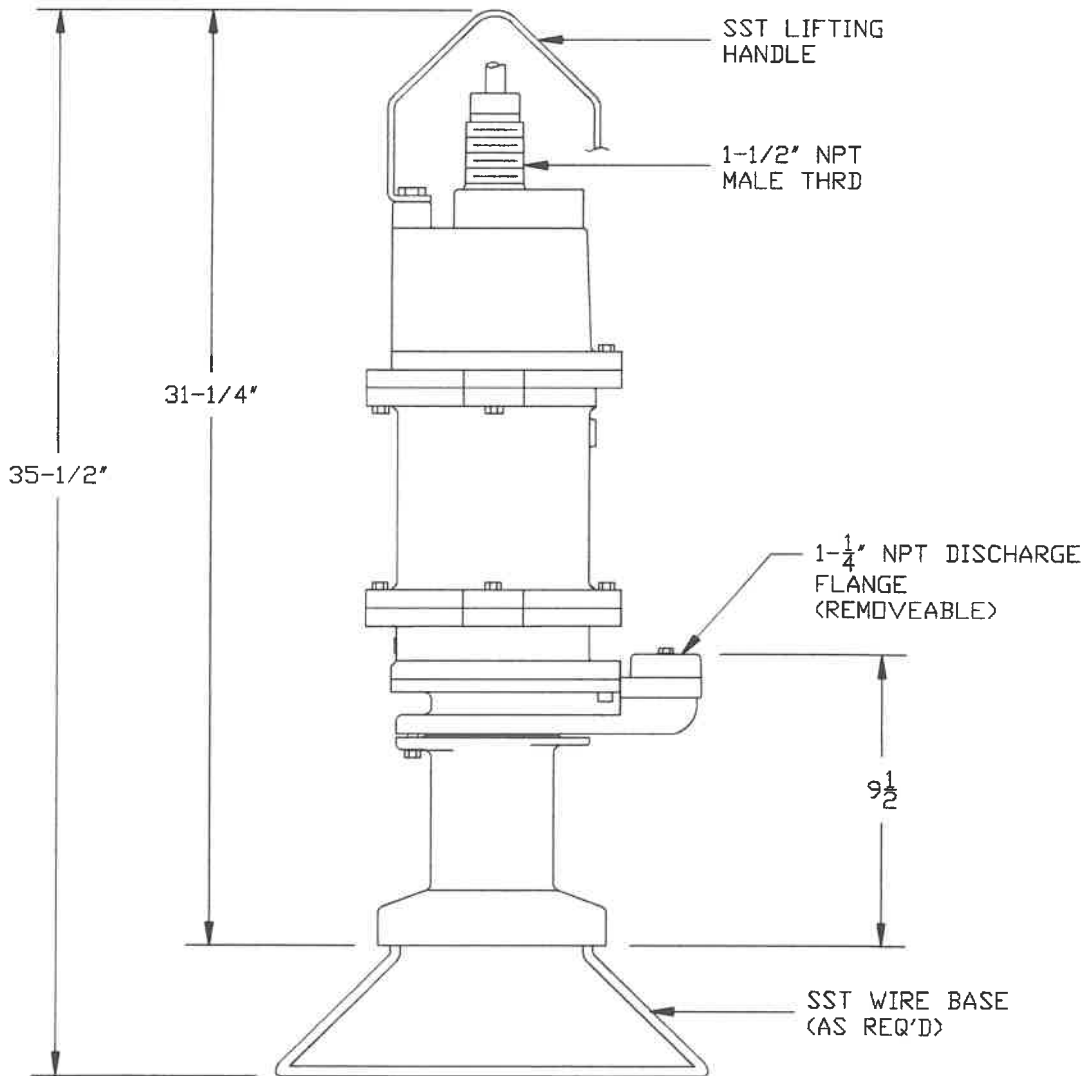
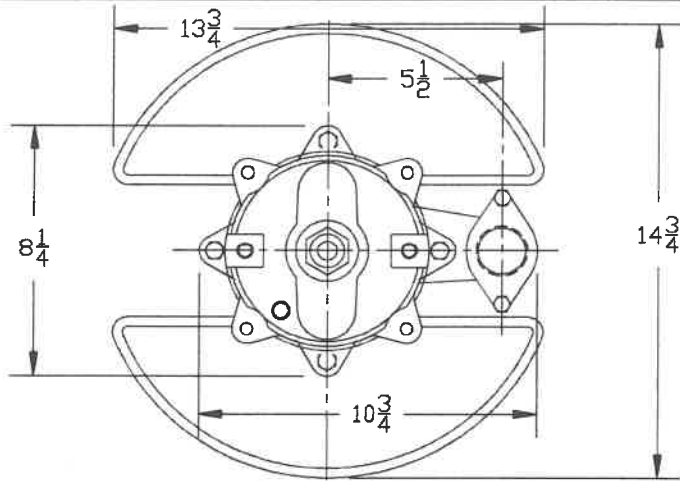

NOTE: ALL DIMENSIONS FOR REFERENCE ONLY

C	SE	03/13/2015
REV	INITIALS	DATE

KEEN PUMP COMPANY KEEN PUMP CO.
 471E ST ROUTE 250 EAST 471E ST ROUTE 250 EAST
 ASHLAND, OHIO 44805 ASHLAND, OHIO 44805
 PHONE: 419-207-9400
 FAX: 419-207-8031

TITLE KPCG 1HP GRINDER PUMP DIMENSIONS			REV.
SCALE NTS	DWG. #	KN-313	
DWG. BY SE	DATE 01/15/2013	C	



Pump Model: KPCG(X)-(C), KPCG(X)-(C)SL

Physical Data:

Discharge Size	1-1/4" NPT or 2-Bolt Flange Vertical
Impeller Type	Progressive Cavity – Rotor w/ Stator
Power/Control Cable Length	30' Standard
Paint	Blue, Waterborne Acrylic, High Build – (1) One Coat, Corrosion-Resistant, Air-Dried

Motor Construction:

Motor Type	Enclosed Submersible Oil Filled
NEMA Insulation Code	Class F
Service Factor	1.0
Motor Protection	Thermal Sensors Embedded in the Windings
Maximum Stator Temperature	266°F (130°C)
Power Cord "C" Pump	14-3 SOOW - 600V, 90° C
Power Cord (Remote Start Kit)	14-5 SOOW – 600V, 90° C
Std. Third Party Approval	FM 3615

Materials of Construction:

Cord Entry	Cast Iron, ASTM A48, Class 35
Motor Housing	Cast Iron, ASTM A48, Class 35
Bearing Housing	Cast Iron, ASTM A48, Class 35
Volute	Cast Iron, ASTM A48, Class 35
Rotor, Wobble	Stainless Steel
Stator, Full Lobe	EPDM
Stator Liner	Nylon
Shaft	ANSI 400 Stainless Steel
*Opt. Rotating "Axial" Slicer	440 SST Hardened 58-60 Rockwell C
*Opt. Stationary "Axial" Slicer	440 SST Hardened 58-60 Rockwell C
Rotating "Radial" Cutter	440 SST Hardened 58-60 Rockwell C
Stationary "Radial" Cutter	440 SST Hardened 58-60 Rockwell C
Inboard Mechanical Seal	Silicon Carbide / Silicon Carbide, Viton® Elastomers
Outboard Mechanical Seal	Silicon Carbide / Silicon Carbide, Viton® Elastomers
Fasteners	ANSI 18-8 or 304 Stainless Steel
O-Rings	Nitrile Rubber
Upper Bearing	Conrad Style Single Row Deep Groove Ball Bearing 100,000 Hours, L-10
Lower Bearing	Conrad Style Single Row Deep Groove Ball Bearing 100,000 Hours, L-10
Sleeve Bearing	Bronze, Sintered



Pump Model: KPCG(X)-(C), KPCG(X)-(C)SL

Thermal Data:

Maximum Liquid	140° F (60° C) Intermittent
Maximum Stator	266° F (130° C)
Heat Sensor	Open: 275° F (135° C) Max. / 257° F (125° C) Min.
	Closed: 205° F (96° C) Max. / 154° F (68° C) Min.
Oil Flash Point	390° F (199° C)

Electrical Data:

RPM	1750			
Electrical Ratings	Heat Sensor	24VDC 5AMPS	115VAC 5AMPS	230VAC 5AMPS
	Seal Fail	300VAC 5mAMPS		
Voltage Tolerance	± 10%			
Internal Start Kit	Start Capacitor = 216 ufd, 250 VAC			
	Run Capacitor = 50 ufd, 370 VAC			

<u>Model "C"</u> Internal Caps (Slicer)	<u>Model "C"</u> Internal Caps (Radial Cutter)	HP	Volts	Phase	NEC Code	Service Factor	Full Load Amps	SF Amps	Start Amps	Full Load KW	Full Load KVA
KPCG-01CSL	KPCG-01C	1	208	1	G	1.0	9.0	9.0	40.5	1.87	2.34
KPCG-21CSL	KPCG-21C	1	230	1	G	1.0	8.0	8.0	37.0	1.84	2.30
<u>Model</u> External Caps (Slicer)	<u>Model</u> External Caps (Radial Cutter)										
KPCG-01SL	KPCG-01	1	208	1	G	1.0	9.0	9.0	40.5	1.87	2.34
KPCG-21SL	KPCG-21	1	230	1	G	1.0	8.0	8.0	37.0	1.84	2.30



SPECIFICATIONS

1 HP Grinder Pumps

Model No. KPCG(X)-C(SL)

Pump Model – Pump shall be of the progressive cavity type, KPCG(SL), with an integrally built-in grinder unit and submersible type motor. KPCG(X)-C or KPCG(X)-C(SL) Series pump and motor assembly shall be FM3615 listed for Class 1, Division 1, Groups C & D hazardous location service. KPCG(X)-C(SL) shall have internal start components (Start capacitor, Run Capacitor, Start switch). **Pumps not manufactured complete in the USA shall not be considered equal.**

Operating Conditions – The pump shall have a non-overloading maximum capacity of 15 GPM, a maximum total dynamic head of 70 feet, and shall use a motor rated at 1 HP and 1750 RPM. The grinder unit shall be capable of macerating all material in typical domestic and commercial sewage, including reasonable amounts of foreign objects such as sanitary napkins, disposable diapers, thin rubber, sanitary wipes, floor pads, small wood, plastic and the like to fine slurry that will easily pass through the pump and 1-1/4" NPT discharge.

Construction – All castings must be manufactured and supplied by a domestic source located in the USA. Major pump components shall be of gray cast iron, ASTM A-48, Class 35, with smooth surfaces devoid of blowholes or other irregularities. All exposed nuts or bolts shall be 304 stainless steel. All metal surfaces coming into contact with the pumpage, other than stainless steel, shall be protected by a factory applied spray coating of primer and an air dry acrylic paint finish to the exterior of the pump.

Sealing design shall incorporate metal-to-metal contact between machined surfaces. Critical mating surfaces where watertight sealing is required shall be machined and fitted with O-rings, designed and constructed to meet FM3615 for Class 1, Division 1, Groups C & D standards. Fittings will be the result of controlled compression of rubber O-rings in two planes and O-ring contact of four sides (rabbet joint construction) without the requirement of a specific torque limit. **No secondary sealing compounds, elliptical O-rings, grease or other devices shall be used.**

Rotor - Progressive cavity full lobe rotor to be hardened and polished stainless steel construction.

Stator – Progressive cavity design stator that has a full lobe. Material shall be ethylene propylene synthetic. Stator material to be acceptable for wastewater, having good resistance properties to heat, weather, grease, detergents, and abrasive materials.

Stator Liner - Stator to be encapsulated by stator liner. Liner material shall be high density polyethylene. Liner to stabilize stator when in use, allowing for improved wear resistance and longer stator life.

Radial Cutter Grinder Construction – Provided as a proven cutting method both grinder impeller and shredding ring shall be of 440 stainless steel hardened to 58-60 Rockwell C. The grinder assembly shall consist of a grinder impeller and shredding ring mounted directly below the volute passage. The grinder impeller is threaded to a stainless steel shaft, locked with a stainless steel screw and washer. The shredding ring shall be secured by a retaining ring which is bolted into the cast iron volute for easy removal. All grinding of solids shall be from the action of the grinder impeller against the shredding ring. There shall be 7,400 cuts / second. **Note: Model number to REMOVE "SL" if specifying radial cutter construction**
Ex. KPCG (Standard pump, external capacitors)



OPTIONAL: Slicer Grinder Construction – Maceration is accomplished by a combination of a rotary slicer and stationary slicer plate. Rotary slicer shall consist of (3) blades which protrude away from the inlet. Rotary slicer shall be bolted to shaft within close tolerance of grinding slicer plate. The stationary slicer plate shall consist of engineered-shaped holes for optimum cutting of debris. A slicer plate shall contain grooved slots to eject pump media away from underside of rotary cutter. Slicer plate shall be fastened with countersunk head screws that are flush with surface of plate. **Pumps with protruded or exposed head fasteners shall be considered not equal.** Both rotary slicer and slicer plate shall be 440C stainless steel hardened to 58-60 Rockwell C.

Seals – Type 21, domestic manufactured, dual mechanical seal construction mounted in tandem, shall protect the motor. Standard construction of primary seal shall be silicon / carbide with Viton® elastomers. Standard construction of secondary seal shall be silicon / carbide with Viton® elastomers. The seal face shall be lapped to a flatness of one light band. **For remote start/run capacitor pumps ONLY**, an electrode shall be mounted in the seal chamber to detect water entering the chamber through the lower seal. Water in the chamber shall cause a red light to turn on at the control box. This signal shall not stop the motor, but shall act as a warning only, indicating service is required. **Lip seal arrangements shall not be considered equal.**

Motor – The pump motor construction shall be per NEMA MG-1 1.15 standard and shall be of the submersible type, rated 1 HP, 1750 RPM. The motor shall be for 60 Hz, either 208 or 230 volt, single-phase operation. Single-phase motors shall be capacitor start, capacitor run type for high starting torque. "C" model pump shall contain both capacitors and start switch housed "internally", below the cord entry. Start and run capacitors, and starting switch will be found remotely in a control box for standard pump model. Major motor operating temperature must not exceed Class B ratings.

The stator winding shall be of the open type with Class F insulation. **Any other construction shall not be considered equal.** The stator shall be pressed into the cast iron motor housing. Winding housing shall be filled with clean, high dielectric oil that lubricates bearings and seals, transferring heat from windings and rotor to the outer cast housing.

Single phase motors shall have automatic reset overload protection attached to the top end of the motor windings to stop the motor if the motor winding temperature reaches 130 degrees C. The high temperature shut-off will cause the pump to cease operation should a control failure cause the pump to run in a dry wet well or any condition that may cause the pump to run outside of the specified operating temperature range.

Internal Start Kit ("C" Model Only) – Start/Run capacitor with start switch securely positioned in dry compartment. A total of (4) bolts quickly removes cord cap for easy servicing.

Bearings / Shaft - The motor shall have two heavy-duty ball bearings and one sleeve bearing to support the pump shaft, taking radial and thrust loadings. Bearings shall be designed to an ABEC® System 1 or better. The upper bearing shall be a Conrad type, single-row, deep groove ball bearing designed to adequately handle the required radial loads. The lower bearing shall be a single-row deep groove ball bearing designed to adequately compensate for the axial loads and radial forces. Bearings shall be designed to deliver a minimum L-10 bearing life of 100,000 hours when operation is within the limitations of the manufacturer's performance curve. The bearings shall be lubricated in oil and will not require maintenance as described in ANSI/HI 1.4-2010 A.6.

Power Cord – The motor power cord shall be 12 Ga. Type SOOW, UL listed, CSA approved cable. The cable jacket shall be sealed at the motor entrance by means of an agency-approved rubber compression washer and compression nut. An epoxy-filled cord cap seals the outer cable jacket and individual leads to prevent water from entering the motor housing. **Compression fittings with quick disconnect molded pins shall not be considered equal.** Cord shall withstand a pull strain to meet FM requirements.

Bond No.: CIC1945046

Agency _____

REQ.P.O# _____

BID BOND

KNOW ALL MEN BY THESE PRESENTS, That we, the undersigned, All Pumps Sales & Service, Inc.
of 2182 Route 75, Kenova, WV 25530, as Principal, and Capitol Indemnity Corporation
of P.O. Box 5900, Madison, WI 53705-0900 a corporation organized and existing under the laws of the State of Wisconsin
with its principal office in the City of Madison, as Surety, are held and firmly bound unto the State of West Virginia, as Obligee, in the penal sum of Five Percent (5%) of Amount Bid (\$ 5% of Amount Bid) for the payment of which, well and truly to be made, we jointly and severally bind ourselves, our heirs, administrators, executors, successors and assigns.

The Condition of the above obligation is such that whereas the Principal has submitted to the Purchasing Section of the Department of Administration a certain bid or proposal, attached hereto and made a part hereof, to enter into a contract in writing for Hawks Nest State Park New Sewage Lift Station

NOW THEREFORE,

(a) If said bid shall be rejected, or

(b) If said bid shall be accepted and the Principal shall enter into a contract in accordance with the bid or proposal attached hereto and shall furnish any other bonds and insurance required by the bid or proposal, and shall in all other respects perform the agreement created by the acceptance of said bid, then this obligation shall be null and void, otherwise this obligation shall remain in full force and effect. It is expressly understood and agreed that the liability of the Surety for any and all claims hereunder shall, in no event, exceed the penal amount of this obligation as herein stated.

The Surety, for the value received, hereby stipulates and agrees that the obligations of said Surety and its bond shall be in no way impaired or affected by any extension of the time within which the Obligee may accept such bid, and said Surety does hereby waive notice of any such extension.

WITNESS, the following signatures and seals of Principal and Surety, executed and sealed by a proper officer of Principal and Surety, or by Principal individually if Principal is an individual, this 27th day of September, 2023.

Principal Seal



All Pumps Sales & Service, Inc.

(Name of Principal)

By

Thomas J. Fellure
(Must be President, Vice President, or Duly Authorized Agent)

President
(Title)

Capitol Indemnity Corporation

(Name of Surety)

Rita Jorgenson
Rita Jorgenson, Attorney-In-Fact

IMPORTANT – Surety executing bonds must be licensed in West Virginia to transact surety insurance, must affix its seal, and must attach a power of attorney with its seal affixed.

When this Bond has been furnished to comply with a statutory or other legal requirement in the location of the Project, any provision in this Bond conflicting with said statutory or legal requirement shall be deemed deleted herefrom and provisions conforming to such statutory or other legal requirement shall be deemed incorporated herein. When so furnished, the intent is that this Bond shall be construed as a statutory bond and not as a common law bond.

Signed and sealed this 27th day of September, 2023.

All Pumps Sales & Service, Inc.

(Principal)

(Seal)

Sherry Feltner (Witness) Thomas J. Feltner

President

(Title)

Capitol Indemnity Corporation

(Surety)

(Seal)

Shelley Shultz
Underwriting Assistant (Witness)

Rita Jorgenson
Rita Jorgenson, Attorney-in-Fact



ACKNOWLEDGMENT OF PRINCIPAL (Individual)

State of _____ }
County of _____ }

On this _____ day of _____, in the year _____, before me personally comes _____, to me known and known to me to be the person who is described in and executed the foregoing instrument, and acknowledges to me that he/she executed the same.

Notary Public

ACKNOWLEDGMENT OF PRINCIPAL (Partnership)

State of _____ }
County of _____ }

On this _____ day of _____, in the year _____, before me personally come(s) _____, a member of the co-partnership of _____, to me known and known to me to be the person who is described in and executed the foregoing instrument, and acknowledges to me that he/she executed the same as the act and deed of the said co-partnership.

Notary Public

ACKNOWLEDGMENT OF PRINCIPAL (Corporation/LLC)

State of WV }
County of Wayne }

On this 5 day of Oct, in the year 2023, before me personally come(s) Thomas Jellure, to me known, who being duly sworn, deposes and says that (he/she resides in the City of Kenova that he/she is the President of the All Pumps Sales & Services Inc., the corporation described in and which executed the foregoing instrument, and that he/she signed his/her name thereto by like order.

Joann Hayton
Notary Public



**CAPITOL INDEMNITY CORPORATION
POWER OF ATTORNEY**

CIC1945046

Bond Number

KNOW ALL MEN BY THESE PRESENTS, That the CAPITOL INDEMNITY CORPORATION, a corporation of the State of Wisconsin, having its principal offices in the City of Middleton, Wisconsin, does make, constitute and appoint

----- JACK ANDERSON; RONALD KAIHOI; RITA JORGENSON -----

its true and lawful Attorney(s)-in-fact, to make, execute, seal and deliver for and on its behalf, as surety, and as its act and deed, any and all bonds, undertakings and contracts of suretyship, provided that no bond or undertaking or contract of suretyship executed under this authority shall exceed in amount the sum of

-----ALL WRITTEN INSTRUMENTS IN AN AMOUNT NOT TO EXCEED: \$20,000,000.00-----

This Power of Attorney is granted and is signed and sealed by facsimile under and by the authority of the following Resolution adopted by the Board of Directors of CAPITOL INDEMNITY CORPORATION at a meeting duly called and held on the 15th day of May, 2002.

"RESOLVED, that the President, Executive Vice President, Vice President, Secretary or Treasurer, acting individually or otherwise, be and they hereby are granted the power and authorization to appoint by a Power of Attorney for the purposes only of executing and attesting bonds and undertakings, and other writings obligatory in the nature thereof, one or more resident vice-presidents, assistant secretaries and attorney(s)-in-fact, each appointee to have the powers and duties usual to such offices to the business of this company; the signature of such officers and seal of the Company may be affixed to any such power of attorney or to any certificate relating thereto by facsimile, and any such power of attorney or certificate bearing such facsimile signatures or facsimile seal shall be valid and binding upon the Company, and any such power so executed and certified by facsimile signatures and facsimile seal shall be valid and binding upon the Company in the future with respect to any bond or undertaking or other writing obligatory in the nature thereof to which it is attached. Any such appointment may be revoked, for cause, or without cause, by any of said officers, at any time."

In connection with obligations in favor of the Florida Department of Transportation only, it is agreed that the power and authority hereby given to the Attorney-in-Fact includes any and all consents for the release of retained percentages and/or final estimates on engineering and construction contracts required by the State of Florida Department of Transportation. It is fully understood that consenting to the State of Florida Department of Transportation making payment of the final estimate to the Contractor and/or its assignee, shall not relieve this surety company of any of its obligations under its bond.

In connection with obligations in favor of the Kentucky Department of Highways only, it is agreed that the power and authority hereby given to the Attorney-in-Fact cannot be modified or revoked unless prior written personal notice of such intent has been given to the Commissioner - Department of Highways of the Commonwealth of Kentucky at least thirty (30) days prior to the modification or revocation.

IN WITNESS WHEREOF, the CAPITOL INDEMNITY CORPORATION has caused these presents to be signed by its officer undersigned and its corporate seal to be hereto affixed duly attested, this 1st day of January, 2020.

Attest:

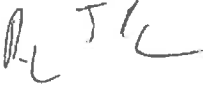
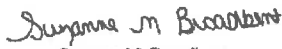
Ryan J. Byrnes
Senior Vice President,
Chief Financial Officer and Treasurer

Suzanne M. Broadbent
Assistant Secretary



CAPITOL INDEMNITY CORPORATION

John L. Sennott, Jr.
Chief Executive Officer and President

STATE OF WISCONSIN }
COUNTY OF DANE } S.S.:

On the 1st day of January, 2020 before me personally came John L. Sennott, Jr., to me known, who being by me duly sworn, did depose and say: that he resides in the County of Hartford, State of Connecticut; that he is Chief Executive Officer and President of CAPITOL INDEMNITY CORPORATION, the corporation described in and which executed the above instrument; that he knows the seal of the said corporation; that the seal affixed to said instrument is such corporate seal: that it was so affixed by order of the Board of Directors of said corporation and that he signed his name thereto by like order.

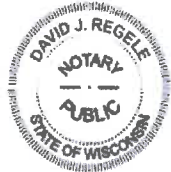

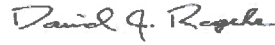

David J. Regele
Notary Public, Dane Co., WI
My Commission Is Permanent

STATE OF WISCONSIN }
COUNTY OF DANE } S.S.:

I, the undersigned, duly elected to the office stated below, now the incumbent in CAPITOL INDEMNITY CORPORATION, a Wisconsin Corporation, authorized to make this certificate, DO HEREBY CERTIFY that the foregoing attached Power of Attorney remains in full force and has not been revoked; and furthermore, that the Resolution of the Board of Directors, set forth in the Power of Attorney is now in force.

Signed and sealed at the City of Middleton, State of Wisconsin this 27th day of September, 2023



Andrew B. Diaz-Matos
Senior Vice President, General Counsel and Secretary

ACKNOWLEDGEMENT OF SURETY

STATE OF MINNESOTA

COUNTY OF CHIPPEWA



On this 27th day of September, 2023, before me, a Notary Public within and for said County, personally appeared **Rita Jorgenson** to me personally known, who being by me duly sworn he/she did say that he/she is the attorney-in-fact of **Capitol Indemnity Corporation**, the corporation named in the foregoing instrument, and the seal affixed to said instrument is the corporation seal of said corporation, and sealed on behalf of said corporation by authority of its Board of Directors and said **Rita Jorgenson** acknowledged said instrument to be the free act and deed of said corporation.

NOTARY PUBLIC

My Commission Expires

1/31/2028

