



The following documentation is an electronically-submitted vendor response to an advertised solicitation from the *West Virginia Purchasing Bulletin* within the Vendor Self-Service portal at wvOASIS.gov. As part of the State of West Virginia's procurement process, and to maintain the transparency of the bid-opening process, this documentation submitted online is publicly posted by the West Virginia Purchasing Division at WVPurchasing.gov with any other vendor responses to this solicitation submitted to the Purchasing Division in hard copy format.

Header @ 3

List View

- General Information**
- Contact
- Default Values
- Discount
- Document Information
- Clarification Request

<p>Procurement Folder: 1214017</p> <p>Procurement Type: Central Purchase Order</p> <p>Vendor ID: VS0000037280 </p> <p>Legal Name: All Around Access LLC</p> <p>Alias/DBA:</p> <p>Total Bid: \$21,892.00</p> <p>Response Date: 05/03/2023 </p> <p>Response Time: 11:17</p> <p>Responded By User ID: allaroundaccess </p> <p>First Name: Rick</p> <p>Last Name: Mellert</p> <p>Email: rick@allaroundaccess.com</p> <p>Phone: 239-206-7594</p>	<p>SO Doc Code: CRFQ</p> <p>SO Dept: 1400</p> <p>SO Doc ID: AGR2300000025</p> <p>Published Date: 4/17/23</p> <p>Close Date: 5/4/23</p> <p>Close Time: 13:30</p> <p>Status: Closed</p> <p>Solicitation Description: ELECTRIC MANLIFT AERIAL WORK PLATFORM </p> <p>Total of Header Attachments: 3</p> <p>Total of All Attachments: 3</p>
--	--



Department of Administration
 Purchasing Division
 2019 Washington Street East
 Post Office Box 50130
 Charleston, WV 25305-0130

**State of West Virginia
 Solicitation Response**

Proc Folder: 1214017		
Solicitation Description: ELECTRIC MANLIFT AERIAL WORK PLATFORM		
Proc Type: Central Purchase Order		
Solicitation Closes	Solicitation Response	Version
2023-05-04 13:30	SR 1400 ESR05032300000005555	1

VENDOR
VS0000037280 All Around Access LLC

Solicitation Number: CRFQ 1400 AGR2300000025
Total Bid: 21892 **Response Date:** 2023-05-03 **Response Time:** 11:17:03
Comments:

FOR INFORMATION CONTACT THE BUYER
 Crystal G Husted
 (304) 558-2402
 crystal.g.husted@wv.gov

Vendor Signature X	FEIN#	DATE
-------------------------------	--------------	-------------

All offers subject to all terms and conditions contained in this solicitation

Line	Comm Ln Desc	Qty	Unit Issue	Unit Price	Ln Total Or Contract Amount
1	Electric Manlift Aerial Work Platform	1.00000	EA	21892.000000	21892.00

Comm Code	Manufacturer	Specification	Model #
22101801			

Commodity Line Comments: New Snorkel S3226E Electric Scissor Lift. Current lead time is 90 days or less. Lead time is subject to change.

Extended Description:

Electric Manlift Aerial Work Platform



Department of Administration
 Purchasing Division
 2019 Washington Street East
 Post Office Box 50130
 Charleston, WV 25305-0130

State of West Virginia
 Centralized Request for Quote
 Equipment

Proc Folder: 1214017		Reason for Modification:	
Doc Description: ELECTRIC MANLIFT AERIAL WORK PLATFORM			
Proc Type: Central Purchase Order			
Date Issued	Solicitation Closes	Solicitation No	Version
2023-04-17	2023-05-04 13:30	CRFQ 1400 AGR2300000025	1

BID RECEIVING LOCATION

BID CLERK
 DEPARTMENT OF ADMINISTRATION
 PURCHASING DIVISION
 2019 WASHINGTON ST E
 CHARLESTON WV 25305
 US

VENDOR

Vendor Customer Code:
 Vendor Name: ALL AROUND ACCESS LLC
 Address: 2095
 Street: 47th AVE NE
 City: NAPLES
 State: FL Country: USA Zip: 34120
 Principal Contact: Rick Mueller
 Vendor Contact Phone: 239-206-7594 Extension:

FOR INFORMATION CONTACT THE BUYER
 Crystal G Husted
 (304) 558-2402
 crystal.g.husted@wv.gov

Vendor Signature X *Rick Mueller* FEIN# 27-3987945 DATE 5/3/2023

All offers subject to all terms and conditions contained in this solicitation

All Around Access LLC

ADDITIONAL INFORMATION

THE STATE OF WEST VIRGINIA PURCHASING DIVISION FOR THE AGENCY, WEST VIRGINIA DEPARTMENT OF AGRICULTURE, IS SOLICITING BIDS TO ESTABLISH A CONTRACT FOR THE ONE-TIME PURCHASE OF A ELECTRIC MANLIFT AERIAL WORK PLATFORM PER THE ATTACHED DOCUMENTS.

***QUESTIONS REGARDING THE SOLICITATION MUST BE SUBMITTED IN WRITING TO CRYSTAL.G.HUSTEAD@WV.GOV PRIOR TO THE QUESTION

INVOICE TO	SHIP TO
------------	---------

AGRICULTURE DEPARTMENT OF ADMINISTRATIVE SERVICES 1900 KANAWHA BLVD E CHARLESTON WV US	AGRICULTURE DEPARTMENT OF FOOD DISTRIBUTION PROGRAM 4496 CEDAR LAKES RD RIPLEY WV US
---	--

Line	Comm Ln Desc	Qty	Unit Issue	Unit Price	Total Price
1	Electric Manlift Aerial Work Platform	1.00000	EA	\$21,892 ⁰⁰	\$21,892 ⁰⁰

Comm Code	Manufacturer	Specification	Model #
22101801	SNORKEL	ELECTRIC SCISSOR LIFT	53226 E

Extended Description:
 Electric Manlift Aerial Work Platform

SCHEDULE OF EVENTS

Line	Event	Event Date
1	VENDOR QUESTION DEADLINE	2023-04-24

ADDENDUM ACKNOWLEDGEMENT FORM
SOLICITATION NO.: CRFQ AGR2300000025

Instructions: Please acknowledge receipt of all addenda issued with this solicitation by completing this addendum acknowledgment form. Check the box next to each addendum received and sign below. Failure to acknowledge addenda may result in bid disqualification.

Acknowledgment: I hereby acknowledge receipt of the following addenda and have made the necessary revisions to my proposal, plans and/or specification, etc.

Addendum Numbers Received:

(Check the box next to each addendum received)

- | | |
|---|--|
| <input type="checkbox"/> Addendum No. 1 | <input type="checkbox"/> Addendum No. 6 |
| <input type="checkbox"/> Addendum No. 2 | <input type="checkbox"/> Addendum No. 7 |
| <input type="checkbox"/> Addendum No. 3 | <input type="checkbox"/> Addendum No. 8 |
| <input type="checkbox"/> Addendum No. 4 | <input type="checkbox"/> Addendum No. 9 |
| <input type="checkbox"/> Addendum No. 5 | <input type="checkbox"/> Addendum No. 10 |

I understand that failure to confirm the receipt of addenda may be cause for rejection of this bid. I further understand that any verbal representation made or assumed to be made during any oral discussion held between Vendor's representatives and any state personnel is not binding. Only the information issued in writing and added to the specifications by an official addendum is binding.

ALL AROUND ACCESS LLC

Company

Paul Muller

Authorized Signature

5/3/2023

Date

NOTE: This addendum acknowledgment should be submitted with the bid to expedite document processing.

DESIGNATED CONTACT: Vendor appoints the individual identified in this Section as the Contract Administrator and the initial point of contact for matters relating to this Contract.

(Printed Name and Title) Rick MELLERT MANAGER
(Address) 2095 47th AVE NE
(Phone Number) / (Fax Number) P# 239-206-7594
(Email address) rick@allaroundaccess.com

CERTIFICATION AND SIGNATURE: By signing below, or submitting documentation through wvOASIS, I certify that: I have reviewed this Solicitation/Contract in its entirety; that I understand the requirements, terms and conditions, and other information contained herein; that this bid, offer or proposal constitutes an offer to the State that cannot be unilaterally withdrawn; that the product or service proposed meets the mandatory requirements contained in the Solicitation/Contract for that product or service, unless otherwise stated herein; that the Vendor accepts the terms and conditions contained in the Solicitation, unless otherwise stated herein; that I am submitting this bid, offer or proposal for review and consideration; that this bid or offer was made without prior understanding, agreement, or connection with any entity submitting a bid or offer for the same material, supplies, equipment or services; that this bid or offer is in all respects fair and without collusion or fraud; that this Contract is accepted or entered into without any prior understanding, agreement, or connection to any other entity that could be considered a violation of law; that I am authorized by the Vendor to execute and submit this bid, offer, or proposal, or any documents related thereto on Vendor's behalf; that I am authorized to bind the vendor in a contractual relationship; and that to the best of my knowledge, the vendor has properly registered with any State agency that may require registration.

By signing below, I further certify that I understand this Contract is subject to the provisions of West Virginia Code § 5A-3-62, which automatically voids certain contract clauses that violate State law; and that pursuant to W. Va. Code 5A-3-63, the entity entering into this contract is prohibited from engaging in a boycott against Israel.

ALL AROUND ACCESS LLC
(Company)
Rick Mellert
(Signature of Authorized Representative)
Rick MELLERT 5/3/2023
(Printed Name and Title of Authorized Representative) (Date)
239-206-7594
(Phone Number) (Fax Number)
rick@allaroundaccess.com
(Email Address)

S3220E/S3226E

ELECTRIC SLAB SCISSOR LIFTS



- Self-propelled electric scissor lifts
- Compact & nimble
- Drives through a standard doorway
- Suitable for indoor and outdoor use
- Easy to use

 **snorkel**™
www.snorkellifts.com

ELECTRIC SLAB SCISSOR LIFTS

S3220E/S3226E

DIMENSIONS	S3220E	S3226E
Max. working height	26 ft	32 ft
Max. platform height (A)	20 ft	26 ft
Platform size (stowed)	28.25 in x 84.38 in	28.25 in x 84.38 in
Platform size (extended)	28.25 in x 102.38 in	28.25 in x 102.38 in
Deck extension length (B)	36 in	36 in
Overall length (D) (with step)	90.6 in	90.6 in
Overall length (D) (step removed)	88.75 in	88.75 in
Overall width (C)	32 in	32 in
Stowed height (E)	85.25 in	90.5 in
Min. height (guard rails folded)	67.75 in	73.13 in
Ground clearance (stowed)	3.75 in	3.75 in
Ground clearance (elevated)	0.75 in	0.75 in

PERFORMANCE		
Platform capacity	900 lbs	500 lbs
Max. wind speed	28 mph	28 mph
Max. drive height	20 ft	26 ft
Max. drive speed (stowed)	2.0 mph	2.0 mph
Max. drive speed (elevated)	0.4 mph	0.4 mph
Raise/lower time	34/43 sec	50/56 sec
Gradeability	25%	25%
Inside turning radius	30 in	30 in
Outside turning radius	93 in	93 in
Tires	15 x 4 non-marking rubber	
Controls	proportional	
Drive system	2-wheel drive	

POWER		
Power source	24V DC battery electric	
Charger	90-240V, 25amp	

WEIGHT		
Weight	4,500 lbs	5,000 lbs

TURNING RADIUS

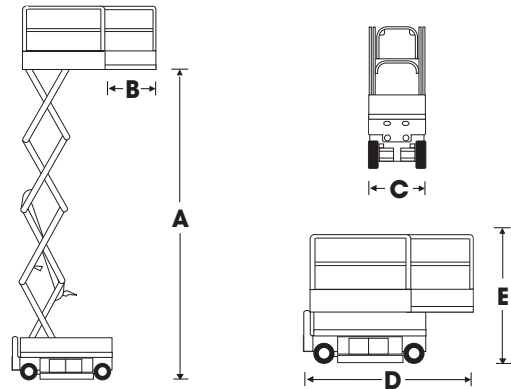
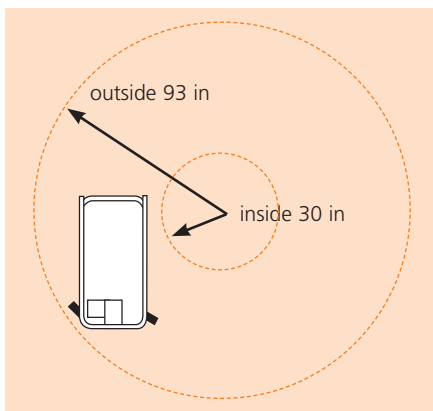

STANDARD FEATURES

- Roll-out deck extension with dual locks
- Non-marking tires
- Swing-out service trays
- Saloon-door style entry gates
- Descent alarm
- All motion alarm
- Proportional controls, including descent
- 2 persons indoor
- 1 person outdoor
- Loading pendant
- Power line to platform
- Platform overload system
- Hour meter & on-board diagnostics display
- Flashing amber light
- Integrated battery charger
- Battery condition indicator
- Crane & forklift points
- Dual lanyard attachment points
- Scissor stack roller slide plates (set of 2)
- 2 year parts & labor, 5 year structural warranty
- ANSI compliant

OPTIONS

- Special paint colors
- 110V AC 800W inverter
- Airline to platform
- Aircraft bumpguard package
- Environmental hydraulic oil
- Snorkel Guard™ secondary guarding system
- Snorkel OnSite™ telematics
- Panel carrier (S3220E only)
- Top rail



P.O. Box 1160
 St. Joseph, MO 64502-1160, USA
 Tel: 1 (785) 989-3000
 Toll-free: 1 (800) 255-0317
 Fax: 1 (785) 989-3070
 Email: sales.usa@snorkellifts.com

www.snorkellifts.com



Snorkel Product Warranty Policy

- 1) **Snorkel** warrants, its authorized sales and service centers (herein referred to as “SSC”), each new machine manufactured and sold by it to be free from defects in material and workmanship for a period of two (2) years from date of delivery to any customer. The warranty will apply subject to the machine being operated in accordance with the rules, precautions, instructions and maintenance requirements outlined in the relevant Snorkel Operator and Parts/Service manuals. Snorkel further warrants the structural components, specifically the mainframe chassis, turntable, booms and/or scissor arms of each new machine manufactured by it to be free from defects in material and workmanship for an additional period of three (3) years. Any such part or parts which, upon examination by the Snorkel Warranty Department or appointed representative, are found to be defective will be replaced or repaired by Snorkel through local authorized Dealers. The structural warranty specifically excludes adverse effects on the machine structure arising from damage, abuse or misuse of the equipment.
- 2) Machines may be held in an authorized Distributor/ SSC’s stock for a maximum period of six (6) months from the date of shipment from Snorkel, before the warranty period is automatically initiated on each machine.
- 3) It is the responsibility of the Distributor/SSC to complete and return to Snorkel a Pre-delivery Inspection Record, Warranty Registration Form, before the act of rental / loan / demonstration of the machine or delivery to an end user. In the case of direct sale to end customers the same responsibility lies with the end customer.
- 4) Any end customer, SSC, distributor or dealer shall not be entitled to the benefits of this warranty and Snorkel shall have no obligations here under unless the “Pre-Delivery and Inspection Record” has been properly completed and returned to the Snorkel Warranty department within fifteen (15) days after delivery of the Snorkel product to the Customer or Dealer’s demonstration / rental fleet. Snorkel must be notified, in writing, within ten (10) days, of any machine sold to a Customer from a Dealer/SSC’s rental fleet during the warranty period.
- 5) Any part or parts which upon examination by the Snorkel Product Support Department are found to be defective within the specified warranty period, will be replaced or repaired at the sole discretion of Snorkel through its local Authorized Distributor/SSC, at no charge. Any parts replaced under warranty must be original Snorkel parts obtained through an authorized Snorkel Distributor/SSC unless expressly agreed otherwise in writing and in advance by Snorkel’s warranty department.



Snorkel Product Warranty Policy

6) All parts claimed under warranty must be held available for return and inspection upon request for a period of 90 days from date of claim submission, it is necessary that all parts are individually tagged or marked with their part number and the warranty claim number. All parts returning should be still in a factory state, free of any alteration to the original design. If the parts are subject to repair it will need to be pre authorized by the Snorkel Product Support Group and or Warranty Department prior to the repair being completed. After 90 days all parts replaced under warranty which have not been returned, to Snorkel should be destroyed. Failure to produce parts requested by the Warranty Administrator for inspection within a period of 14 days will result in the claim being automatically rejected in full. Materials returned for warranty inspection must have the following procedure:

- Carefully packaged to prevent additional damage during shipping
- Drained of all contents and all open ports capped or plugged
- Shipped in a container tagged or marked with the RMA number
- Shipped PREPAID (ground service only). Any item(s) returned for warranty by any other means may be refused and returned, unless prior approval is agreed with Snorkel.

7) At the direction of the Snorkel Warranty department, any component part(s) of Snorkel products to be replaced or repaired under this warranty program must be returned freight prepaid for inspection. An RMA (Returns material authorization) must be requested from Snorkel Warranty department, a copy to be placed with the returning component part(s).

8) All warranty replacement parts will be shipped freight prepaid (standard charges, ground shipping only) from the Snorkel Parts department, Service Department or from the Vendor to Dealer/SSC or Customer. Any other shipping method is the customer responsibility.

9) All warranty claims are subject to approval by Snorkel Service department. Snorkel reserves the right to limit or adjust claims with regard to defective parts, labor or travel time based on usual and customary guidelines.

10) Reimbursement policy, labor will be paid at 75% of posted hourly shop rate. Travel time will be paid at \$50 per hour up to a maximum of 3 hours. Snorkel will pay 1 hour of troubleshooting time per warranty claim, unless expressly agreed otherwise in writing and in advance by Snorkel's Warranty Department. An annual rate declaration must to be supplied to the Snorkel Warranty administrator by January 31st and will be used as the reimbursable rate for that calendar year.



Snorkel Product Warranty Policy

REPLACEMENT PARTS WARRANTY

1. Any part replaced under this limited warranty is not subject to further warranty cover beyond the normal warranty period of the machine upon which the part was installed.
2. Any replacement parts sold (not delivered under a warranty claim) will be subject to a warranty period of (6) six months from the date of invoice.
3. Parts held by an authorized Distributor/SSC are covered under warranty for a period of (12) twelve months from the date of invoice, provided that those parts have been subject to appropriate storage to prevent damage and deterioration (conditional on Snorkel review).

CLAIM PROCEDURE

The Snorkel Warranty department must be notified within forty-eight hours (48) of any possible warranty situation during the applicable warranty period. Personnel performing major warranty repair or parts replacement must obtain specific approval by the Snorkel Warranty department prior to performing the warranty repair or replacement.

When a Distributor/SSC / Customer perceive a warranty issue to exist the following steps must be adhered to:

- Customer/SSC / Distributor to place a purchase order for genuine Snorkel replacement parts.
- Snorkel to dispatch parts via the requested method (in line with the required response time).
- Confirmation that a qualified technician is available to replace the part and that this person has been accepted by Snorkel to carry out such work under the warranty of the machine. Failure to do this may nullify the warranty.
- Customer /SSC / Distributor to allocate a warranty claim number to the repair.
- All correspondence in respect of the claim to be on an official Snorkel warranty claim form as supplied by Snorkel's warranty department.
- All warranty claims must be submitted within 30 days of the date of the machine repair.

FREIGHT DAMAGE

- If a machine is received in a damaged condition, then the damage must be noted on the bill of lading and /or delivery documents and photographs must be taken at the point of delivery, prior to signing acceptance of the consignment.
- The freight company & Snorkel must be contacted by the Distributor and a damage claim registered by either party immediately.



Snorkel Product Warranty Policy

- The above requirements apply only to freight damage associated with equipment supplied by Snorkel transport. Customer freight issues are excluded from this warranty policy.

THIS PRODUCT WARRANTY POLICY SPECIFICALLY EXCLUDES:

- 1.** Engines, motors, tires and batteries are manufactured by specialist suppliers to Snorkel, who furnish their own warranty policies. Snorkel will, however, to the extent permitted pass through any such warranty protection to the Distributor/SSC / Customer.
- 2.** Any Snorkel products which has been modified or altered outside Snorkel factories without written approval, if such modification or alteration, in the sole judgment of Snorkel Engineering and/or Service Departments, adversely affects the stability, reliability or service life of the Snorkel product or any component thereof.
- 3.** Any Snorkel product which has been subject to misuse and abuse, improper maintenance or accident. “Misuse” includes but is not limited to operation beyond the factory-rated load capacity and speeds. “Improper maintenance” includes but is not limited to failure to follow the recommendations contained in the Snorkel Operation, Maintenance, and repair Parts Manuals.
- 4.** Normal wear of any Snorkel component part(s). Normal wear of component parts may vary with the type, application or type of environment in which the machine may be used; such as, but not limited to sandblasting applications.
- 5.** Routine maintenance, routine maintenance items and minor adjustments are not covered by this warranty, including but not limited to hydraulic fluid, filters and lubrication, paint and decals engine tune-up, brake adjustments etc. Snorkel will not cover leaks from fittings, hoses and any other connection points after the unit has been in service for 90 days or 150 hours of operation which ever comes first.
- 6.** Any Snorkel product that has come into direct contact with any chemical or abrasive material.
- 7.** Incidental or consequential expenses, losses, or damages related to any part or equipment failure, including but not limited to freight cost to transport the machine to a repair facility, downtime of the machine, lost time for workers, lost orders, lost rental revenue, lost profits, expenses or increased cost. This warranty is expressly in lieu of all other warranties, representations or liabilities of Snorkel either expressed or implied, unless otherwise amended in writing by Snorkel.
- 8.** Snorkel warranty policy does not cover any duties, taxes, environmental fees including without limitation, disposal or handling of tires, batteries and petrochemical items.
- 9.** Items specifically excluded are: fuel injectors, motor brushes, glow plugs, contactor tips and springs, filters, lamp bulbs, lamp lenses, coolants, lubricants, brake pads and cleaning materials.



Snorkel Product Warranty Policy

10. Failure of replacement parts due to fault misdiagnosis or incorrect fitting by the Distributor/SSC / Customer.

SNORKEL MAKES NO WARRANTIES WHICH EXTEND BEYOND THE DESCRIPTION OF THIS LIMITED WARRANTY. SNORKEL MAKES NO IMPLIED WARRANTY OF MERCHANTABILITY OR FITNESS FOR A PARTICULAR PURPOSE AND DISCLAIMS ALL LIABILITY FOR INCIDENTAL OR CONSEQUENTIAL DAMAGES, INCLUDING BUT NOT LIMITED TO INJURY TO PERSONS OR PROPERTY.

Wherever possible the end customer shall obtain all warranty support & make all warranty claims through the local Snorkel authorized Distributor /SSC / Dealer. Warranty support should be from the Distributor /SSC / Dealer from whom the Snorkel product was purchased. Where Snorkel equipment is supplied directly from the factory the end customer, if unable to contact a Distributor/SSC / Dealer, may contact the Snorkel Warranty Department for further assistance.

APPEAL

The buyer may appeal in writing against a rejected or adjusted claim to Snorkel warranty department within a period of 21 days of receiving the rejection or adjustment notice. The appeal should be grounded on express reasons and supported by relevant evidence. Appeals received outside of this time limit will not be considered.



Snorkel Product Warranty Policy

SNORKEL WARRANTY SCHEDULE

Limited Warranty Periods

<u>Item</u>	<u>Warranty Period</u>
New machine materials and workmanship	2 year parts replacement
Structural components (Chassis, Turntable, Booms, Scissors)	5 years parts replacement or repair
Parts held in a Distributor's stock	12 months from date of invoice, subject to adequate storage / protection.
Parts sold (non warranty)	6 months from date of invoice
Batteries supplied on new machines	6 months from warranty registration date
Other specifically excluded parts: Fuel injectors Motor brushes Glow plugs Contactor tips and springs Oils Filters Lamp bulbs Lamp lenses Coolants Lubricants Cleaning materials All consumable / wear parts.	Not covered by Warranty