



The following documentation is an electronically-submitted vendor response to an advertised solicitation from the *West Virginia Purchasing Bulletin* within the Vendor Self-Service portal at *wvOASIS.gov*. As part of the State of West Virginia's procurement process, and to maintain the transparency of the bid-opening process, this documentation submitted online is publicly posted by the West Virginia Purchasing Division at *WVPurchasing.gov* with any other vendor responses to this solicitation submitted to the Purchasing Division in hard copy format.

Header @ 3

List View

General Information | Contact | Default Values | Discount | Document Information | Clarification Request

Procurement Folder: 1047522

Procurement Type: Central Purchase Order

Vendor ID: VS0000039427

Legal Name: NetZero USA Holdings Inc

Alias/DBA: NetZero USA

Total Bid: \$27,471.60

Response Date: 06/15/2022

Response Time: 16:26

Responded By User ID: NZUSAWV

First Name: Drew

Last Name: Sinclair

Email: drew@netzero-usa.com

Phone: 7707540200

SO Doc Code: CRFQ

SO Dept: 0803

SO Doc ID: DOT2200000176

Published Date: 6/3/22

Close Date: 6/16/22

Close Time: 13:30

Status: Closed

Solicitation Description: Flood Lights and Mounts 1022B180

Total of Header Attachments: 3

Total of All Attachments: 3



Department of Administration
 Purchasing Division
 2019 Washington Street East
 Post Office Box 50130
 Charleston, WV 25305-0130

**State of West Virginia
 Solicitation Response**

Proc Folder: 1047522
Solicitation Description: Flood Lights and Mounts 1022B180
Proc Type: Central Purchase Order

Solicitation Closes	Solicitation Response	Version
2022-06-16 13:30	SR 0803 ESR06092200000007775	1

VENDOR
 VS0000039427
 NetZero USA Holdings Inc

Solicitation Number: CRFQ 0803 DOT2200000176
Total Bid: 27471.59999999999854480847716 **Response Date:** 2022-06-15 **Response Time:** 16:26:22

Comments: In business since 2009, NetZero USA® is the lighting industry s first and only vertically integrated energy reduction company. From product design and manufacturing, to financing, installation, and service and everything in between we exercise full control over our products and services. We partner with global industry leaders to bring the latest technology to market and facilitate our best-in-class programs and services.
 Our mission is to be a trusted partner, delivering the right amount of light with the most amount of life, while reducing energy waste, at a net-zero cost to our customers.
 Thank you for your consideration.

FOR INFORMATION CONTACT THE BUYER
 John W Estep
 304-558-2566
 john.w.estep@wv.gov

--

All offers subject to all terms and conditions contained in this solicitation

Line	Comm Ln Desc	Qty	Unit Issue	Unit Price	Ln Total Or Contract Amount
1	Large Square Double LED Flood Lights	60.00000	EA	283.590000	17015.40

Comm Code	Manufacturer	Specification	Model #
39111611			

Commodity Line Comments: Please see included spec sheet.

Extended Description:

Large Square Double LED Flood Lights

Line	Comm Ln Desc	Qty	Unit Issue	Unit Price	Ln Total Or Contract Amount
2	Hardware Mounting Kit	60.00000	EA	11.460000	687.60

Comm Code	Manufacturer	Specification	Model #
31162300			

Commodity Line Comments: Please see included spec sheet.

Extended Description:

Hardware Mounting Kit for Large Square Double LED Flood Lights

Line	Comm Ln Desc	Qty	Unit Issue	Unit Price	Ln Total Or Contract Amount
3	Large Square Single LED Flood Lights	60.00000	EA	155.050000	9303.00

Comm Code	Manufacturer	Specification	Model #
39111611			

Commodity Line Comments:

Extended Description:

Large Square Single LED Flood Lights

Line	Comm Ln Desc	Qty	Unit Issue	Unit Price	Ln Total Or Contract Amount
4	Hardware Mounting Kit	60.00000	EA	7.760000	465.60

Comm Code	Manufacturer	Specification	Model #
31162300			

Commodity Line Comments:

Extended Description:

Hardware Mounting Kit for Large Square Single Flood LED Lights



SERIES FEATURES

- ✓ American Designed & Engineered
- ✓ Interchangeable Mounting Options
- ✓ Multiple Outdoor Applications
- ✓ 0-10V Dimmable
- ✓ Control Systems Compatible
- ✓ DLC Certified
- ✓ UL 1598C Listed
- ✓ Non-prorated Warranty
- ✓ Performance Guarantee



SERIES OVERVIEW

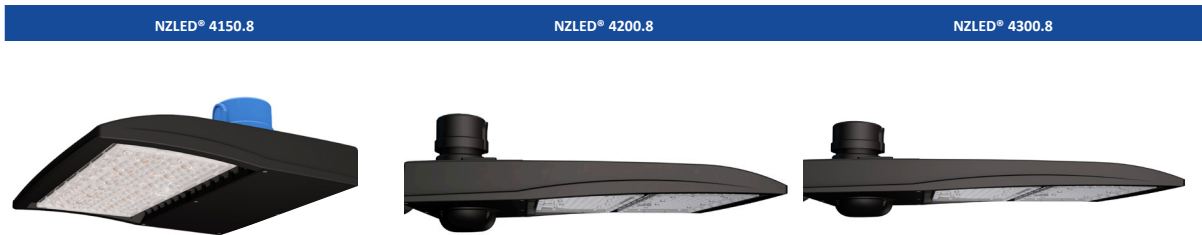

	NZLED [®] 4150.8	NZLED [®] 4200.8	NZLED [®] 4300.8
Part Number	NZ-4150.8-CT3A2-BR10SPA&D50	NZ-4200.8-CT3A2-BR10SPA&D50	NZ-4300.8WCT3B1-BRSA&D50
Description	150W Multi-Mount Area Light	200W Multi-Mount Area Light	300W Multi-Mount Area Light
Type	Replacement / New Construction	Replacement / New Construction	Replacement / New Construction
Applications	Exterior Flood / Parking	Exterior Flood / Parking	Exterior Flood / Parking
CCT	5000K	5000K	5000K
Input Power	150W	200W	298.86W
Lumen Output	21000	26819	40856
Certifications	DLC, UL 1598C	DLC, UL 1598C	DLC, UL 1598C
Dimensions	13.1" x 20.2" x 3.2"	13.1" x 27" x 3.5"	13.1" x 27" x 3.5"
Driver	Meanwell	Meanwell	Meanwell
Grounded	YES	YES	YES
Housing Color	Brown	Brown	Brown

SERIES WARRANTY

	NZLED [®] 4150.8	NZLED [®] 4200.8	NZLED [®] 4300.8
Warranty	5 Years	5 Years	5 Years
L70 Lifetime	>100K Hours	>100K Hours	>100K Hours



SERIES INFO

	NZLED [®] 4150.8	NZLED [®] 4200.8	NZLED [®] 4300.8
Input Voltage	AC100-277V	AC100-277V	AC100-277V
Operating Temp.	-4°F TO 113°F	-4°F TO 113°F	-4°F TO 113°F
IP Rating	IP65	IP65	IP65
0-10V Dimmable	YES	YES	YES
User-Tunable	-	-	-
Controls Compatible	-	-	-
Dark Sky Compliant	-	-	-
Accessories	4150-FM, 4000-PC	4200-FM, 4000-PC	4300-FM, 4000-PC
Options	-	-	-
Ordering Notes	Includes AM/DM mount, others available separately	Includes AM/DM mount, others available separately	Includes AM/DM mount, others available separately

SERIES CERTIFICATIONS

	NZLED [®] 4150.8	NZLED [®] 4200.8	NZLED [®] 4300.8
DLC Model No.	NZ-4150.8-CT3A2-abcdef	NZ-4200.8-CT3A2-abcdef	NZ-4300.8-CT3A3-50
DLC ID	PL60CUD61ZRM	PL7S9JLD32VC	PL369365C2ZR
UL No.	E498108	E498108	E498108

SERIES TESTING DATA

	NZLED [®] 4150.8	NZLED [®] 4200.8	NZLED [®] 4300.8
Lumens	19431.7	25474.5	40856
Wattage	149.01	199.31	298.86
Efficacy	130.41	127.81	136.71
Power Factor	0.9	0.9	0.9
CCT	5000	5000	5000
CRI	75	76	70
Harmonic Distortion	15 %	15 %	15 %

SERIES DIAGRAM

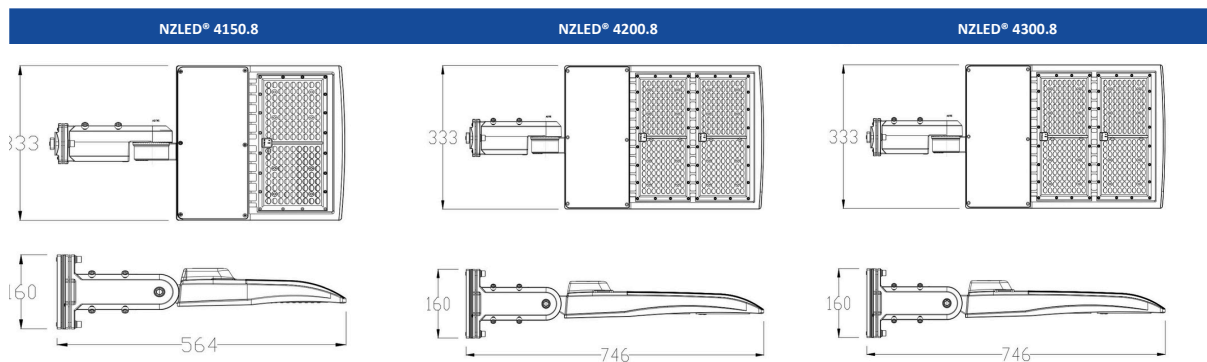



SERIES ACCESSORIES

	ACC 4000-FM	ACC 4000-AM/DM	ACC 4000-PC
			
Part Number	NZ-4150/4200/4300-FM	NZ-4000-AM/DM	NZ-4000.PC
Description	Flood Light Mount	Area Light Universal Arm / Direct Mount	Area Light / Flood Light Photo Cell
Fits Products	4150.8, 4200.8, 4300.8	4150.8, 4200.8, 4300.8	4150, 4200.8, 4300.8
Ordering Notes	Included with 4150-F Flood Light	Included with 4150.8, 4200.8, 4300.8 Area Lights	-



EXCLUSIVE LIMITED WARRANTY

In consideration of the repairs and work (the "Property Improvement Work") to the property located at the below listed address (the "Improved Property") and the sale of lighting adaptors, hardware and fixtures bearing the NetZero USA name and installed in connection with same (the "Lighting Products"), the undersigned Lighting Owner(s) hereby accept and agree to the terms of this Exclusive Limited Warranty.

Warranty and Liability Limitation

NetZero USA hereby warrants to the below listed Lighting Owner(s) that; (i) all Lighting Products shall substantially conform within industry tolerances to their published specifications for the period(s) listed under "Product Warranty Period Enumeration" on page two of this document, provided they are installed in accordance with the manufacturer's instructions and specifications, from and after the date on which the Property Improvement Work is completed (the "Warranty Date") by NetZero USA, or from and after the date on which the Lighting Products were sold to the Lighting Owner (in cases where NetZero USA did not install the Lighting Products). NetZero USA further warrants that it will repair or replace, at no cost to the Lighting Owner(s), any Lighting Product that does not comply with this warranty, subject to the terms and conditions herein. In lieu of repair or replacement, NetZero USA may, at its option, refund the purchase price of the Lighting Products that do not conform to this warranty. THIS WARRANTY IS EXCLUSIVE AND IS IN LIEU OF ALL OTHER WARRANTIES, EXPRESSED OR IMPLIED, INCLUDING, BUT NOT LIMITED TO, ANY IMPLIED WARRANTIES OF MERCHANTABILITY, FITNESS FOR A PARTICULAR USE AND/OR NON-INFRINGEMENT, AND NetZero USA HEREBY EXPRESSLY DISCLAIMS ALL SUCH OTHER WARRANTIES. This warranty does not extend to the following: (a) nonconformities, loss or damage not reported by the Lighting Owner(s) to NetZero USA in writing within six months after they discovered, or should have discovered, the loss or damage, (b) nonconformities, loss or damage caused by defects in project design, installation or materials which the Lighting Owner(s) supplied, installed or had installed under their direction, (c) secondary loss or damage, such as personal injury, death or property damage, (d) nonconformities, loss or damage from normal wear and tear, (e) nonconformities, loss or damage from normal shrinkage caused by drying of the improvements within tolerances of building standards, (f) nonconformities, loss or damages from dampness and condensation due to insufficient ventilation after occupancy, (g) nonconformities, loss or damage from negligence, improper maintenance or alteration of the improvements by parties other than NetZero USA, (h) nonconformities, loss or damage from failure to maintain the improvements in good repair; (i) nonconformities, loss or damage that the Lighting Owner(s), whenever feasible, have not taken timely action to minimize; (j) nonconformities, loss or damage due to acts of God, including, but not limited to: fire, explosion, smoke, water escape, windstorm, hail or lightning, falling trees, aircraft and vehicles, flood, and earthquake; (k) nonconformities, loss or damage from soil movement which is compensated by legislation or covered by insurance; (l) nonconformities, loss or damage due to defects in the existing structure where the Lighting Products are installed; (m) nonconformities, loss or damage due to exposure of the Lighting Products to abnormal electrical conditions, including but not limited to electrical surges or swells; and (n) nonconformities, loss or damage caused by exposure of the Lighting Products to environmental or electrical conditions outside the specified tolerances for the Lighting Products, including but not limited to tolerances for ambient temperature and power factor. Lighting Owner's sole and exclusive remedy and NetZero USA's sole liability for any claim shall be limited to the repair, replacement or purchase price refund set forth herein for the Lighting Products shown to be defective or other than as warranted, and NetZero USA shall not be liable otherwise, including for indirect, special, exemplary, punitive, incidental or consequential damages or for business interruption, lost profits or injury to goodwill, whether arising out of breach of warranty, negligence, strict liability in tort or other causes.

Lighting Owner

Company Name: _____ Executed: (Month) _____, (Day) _____, 20____

Address: _____ Print Name: _____

City: _____ Title: _____

State/Region: _____

Zip: _____ Signature: _____

NetZero USA Holdings Inc, 7565 Industrial Ct., Alpharetta, GA 30004



EXCLUSIVE LIMITED WARRANTY

Product Warranty Periods

P/N	Description	Warranty Period	P/N	Description	Warranty Period
0325	NZLED® 2ft Level III Kit 30W	5 Years	6208.2	NZLED® 8 Inch Down Light 20W	5 Years
0327	NZLED® 2ft Level III Kit 30W	7 Years	6258	NZLED® 8 Inch Down Light 25W	5 Years
0345	NZLED® 4ft Level III Kit 30W	5 Years	8150	NZLED® Canopy Light 150W	7 Years
0347	NZLED® 4ft Level III Kit 30W	7 Years	8240	NZLED® 2x2 Flat Panel 40W	7 Years
0445	NZLED® 4ft Level III Kit 40W	5 Years	8240-MK	NZLED® 2x2 Multi-Kelvin Flat Panel 40W	7 Years
0447	NZLED® 4ft Level III Kit 40W	7 Years	8450	NZLED® 2x4 Flat Panel 50W	7 Years
1230	NZLED® 2x2 Center Basket Retrofit 30W	7 Years	8450-MK	NZLED® 2x4 Multi-Kelvin Flat Panel 50W	7 Years
1436	NZLED® 2x4 Center Basket Retrofit 36W	7 Years	9006	NZLED® Dual Head - CU2	5 Years
2750	NZLED® Ground Mount Flood 50W	5 Years	9008	NZLED® Exit Sign - CER	5 Years
3230	NZLED® 2x2 Center Basket Troffer 30W	7 Years	9010	NZLED® Exit Combo - CCR	5 Years
3234	NZLED® 2x4 Center Basket Troffer 34W	7 Years	9035	NZLED® HID Retrofit 35W	7 Years
3364	NZLED® 4ft. Vaportite 36W	5 Years	9080	NZLED® HID Retrofit 80W	7 Years
4010	NZLED® Wall Pack 100W	7 Years	9081	NZLED® Lowbay 80W	7 Years
4010-DS	NZLED® Full Cut-Off Wall Pack 100W	7 Years	9110	NZLED® Highbay 110W	7 Years
4020	NZLED® Mini Wall Pack 20W	5 Years	9120	NZLED® HID Retrofit 120W	7 Years
40255	NZLED® Parking Garage Light 55W	5 Years	9150	NZLED® HID Retrofit 150W	7 Years
4060	NZLED® Wall Pack 60W	7 Years	9160	NZLED® Highbay 160W	7 Years
4060-DS	NZLED® Full Cut-Off Wall Pack 60W	7 Years	9200	NZLED® HID Retrofit 200W	7 Years
4060-R	NZLED® Rotating Wall Pack 60W	5 Years	9220	NZLED® Highbay 220W	7 Years
4150	NZLED® Shoebox/Flood 150W	5 Years	9320	NZLED® HID Retrofit 320W	7 Years
4200	NZLED® Shoebox/Flood 200W	5 Years	9321	NZLED® Highbay 320W	7 Years
4300	NZLED® Shoebox/Flood 300W	5 Years	9400	NZLED® HID Retrofit 400W	7 Years
4315	NZLED® Flood 150W	5 Years	9432	NZLED® 4ft Shop Light 32W	5 Years
4336	NZLED® Pole Mount Shoebox 400W	7 Years	9822	NZLED® Strip Kit 20W	10 Years
6009	NZLED® Cobb Light 9W	5 Years	9834	NZLED® Strip Kit 30W	10 Years
6030	NZLED® Cobb Light 30W	5 Years	9844	NZLED® Strip Kit 40W	10 Years
6080	NZLED® Cobb Light 80W	5 Years	9844-D	NZLED® Strip Kit 40W Dimmable	10 Years
6100	NZLED® Cobb Light 100W	5 Years	9844-IO	NZLED® Strip Kit 40W In/Outboard	10 Years
6156	NZLED® 6 Inch Down Light 15W	5 Years	9865	NZLED® 8ft Shop Light 65W	5 Years
6156.2	NZLED® 6 Inch Down Light 15W	5 Years	9866	NZLED® Strip Kit 60W (6 Strip)	10 Years
6158.2	NZLED® 8 Inch Down Light 15W	5 Years	9868	NZLED® Strip Kit 60W (8 Strip)	10 Years
6206.2	NZLED® 8 Inch Down Light 20W	5 Years			

Lighting Owner

Print Name: _____

Signature: _____

Title: _____

Date: _____

NetZero USA Holdings Inc, 7565 Industrial Ct., Alpharetta, GA 30004



Better Quality, Healthier Light at a Net-Zero Cost



NetZero USA® & Equalis Group

Publicly Procured Contract Vehicle

NetZero USA® Contract Highlights

- Expert team of lighting professionals with a **proven track record** in implementing municipal projects nationwide. We handle every aspect from start to finish – on time and on budget in a turn-key solution.
- Below-market pricing for Equalis Group Members, which – combined with available utility incentives – allows members to upgrade with little to no out-of-pocket cost.
- Products are backed by our industry-exclusive Non-Prorated Warranty. If a product fails, we will repair or replace it at no additional charge for the full life of the warranty.

Who is NetZero USA®?

In business since 2009, NetZero USA® is the lighting industry's first – and only – vertically integrated energy reduction company. From product design and manufacturing, to financing, installation, and service – and everything in between – we exercise full control over our products and services. We partner with global industry leaders to bring the latest technology to market and facilitate our best-in-class programs and services. Our mission is to be a trusted partner, delivering the right amount of light with the most amount of life, while reducing energy waste, at a net-zero cost to our customers.

Save Time... we've done the procurement work so you don't have to.

Save Money... your dollar goes further with the collective buying power of Equalis Group.

Stay Legal... our competitive procurement process delivers statutory compliance in every state.

Contract #: R10-1133C

Lead Agency: Region 10 ESC

Initial Term: 05.01.2022 – 04.30.2025

Renewable Through: 04.30.2027

Get Started



Learn more about how we can help you achieve your procurement goals while Saving Time, Saving Money & Staying Legal. Email Engage@EqualisGroup.org or visit EqualisGroup.org/Map to connect with your dedicated Member Engagement Resource today.

Created by Public Sector Organizations for Public Sector Organizations



Who is Equalis Group?

Equalis Group is a Member-Driven, Supplier-Centric organization that embodies the power of partnership. Equalis Group operates with the guiding principle that when the objectives of buyers and sellers are aligned, sustainable value is created, transcending that of the typical short-term transactional relationship. With this differentiated approach, Equalis Group is not just a cooperative purchasing organization; we are a family.

We leverage Equalis Group members' combined buying power to command better pricing and favorable contract

terms from suppliers. We develop and administer a diverse portfolio of cooperative purchasing programs that cover a wide range of products and services and provide our members with a legal and compliant exemption to the bid/request for proposals (RFP) process.

Each program in our rapidly growing portfolio provides our members with contracting compliance and the ability to configure the solution that best meets their individual needs while achieving the lowest Total Cost of Ownership.

Time Saved through Equalis Group = More Resources for You to Invest

How many hours and over how many weeks or months does your team invest in a typical solicitation process? How many solicitations does your organization publish each year? How much time and effort can your organization save by leveraging Equalis Group's already-procured portfolio of programs? In what ways can you re-invest that saved time and energy to fulfill your organization's purpose?

Your Solicitation Process Today



Your Implementation Process with Equalis Group



Become a Member of Equalis Group

If you are not already a member, you can join Equalis Group in just minutes and immediately access our portfolio of cooperative purchasing programs. Simply visit www.equalisgroup.org/member-registration to get started. There are no dues, fees, or obligations.