



The following documentation is an electronically-submitted vendor response to an advertised solicitation from the *West Virginia Purchasing Bulletin* within the Vendor Self-Service portal at wvOASIS.gov. As part of the State of West Virginia's procurement process, and to maintain the transparency of the bid-opening process, this documentation submitted online is publicly posted by the West Virginia Purchasing Division at WVPurchasing.gov with any other vendor responses to this solicitation submitted to the Purchasing Division in hard copy format.

Header 1

List View

General Information | [Contact](#) | [Default Values](#) | [Discount](#) | [Document Information](#) | [Clarification Request](#)

Procurement Folder: 929602

Procurement Type: Central Purchase Order

Vendor ID: VS0000002427

Legal Name: Technology International Inc

Alias/DBA:

Total Bid: \$209,134.00

Response Date: 10/12/2021

Response Time: 13:25

Responded By User ID: tii123

First Name: Michael

Last Name: Rosenberg

Email: tii@tii-usa.com

Phone: 4073592373

SO Doc Code: CRFQ

SO Dept: 0803

SO Doc ID: DOT2200000048

Published Date: 9/23/21

Close Date: 10/12/21

Close Time: 13:30

Status: Closed

Solicitation Description: 05220081 - PRESTRESSED
CONCRETE BEAMS FOR FALLS

Total of Header Attachments: 1

Total of All Attachments: 1



Department of Administration
 Purchasing Division
 2019 Washington Street East
 Post Office Box 50130
 Charleston, WV 25305-0130

**State of West Virginia
 Solicitation Response**

Proc Folder: 929602
Solicitation Description: 05220081 - PRESTRESSED CONCRETE BEAMS FOR FALLS BRIDGE
Proc Type: Central Purchase Order

Solicitation Closes	Solicitation Response	Version
2021-10-12 13:30	SR 0803 ESR10122100000002362	1

VENDOR
 VS0000002427
 Technology International Inc

Solicitation Number: CRFQ 0803 DOT2200000048
Total Bid: 209134
Response Date: 2021-10-12
Response Time: 13:25:44
Comments:

FOR INFORMATION CONTACT THE BUYER

Jessica L Hovanec
 304-558-2314
 jessica.l.hovanec@wv.gov

Vendor Signature X **FEIN#** **DATE**

All offers subject to all terms and conditions contained in this solicitation

Line	Comm Ln Desc	Qty	Unit Issue	Unit Price	Ln Total Or Contract Amount
1	EXTERIOR BEAMS	2.00000	EA	23213.000000	46426.00

Comm Code	Manufacturer	Specification	Model #
30103619			

Commodity Line Comments:

Extended Description:

33" DEPTH X 36" WIDTH BY 51'-6" OVERALL LEGTH (SHIP WITH GUARDRAIL & HARDWARE ATTACHED)

Line	Comm Ln Desc	Qty	Unit Issue	Unit Price	Ln Total Or Contract Amount
2	INTERIOR BEAMS	7.00000	EA	23213.000000	162491.00

Comm Code	Manufacturer	Specification	Model #
30103619			

Commodity Line Comments:

Extended Description:

33" DEPTH X 336" WIDTH BY 61'-6" OVERALL LENGTH

Line	Comm Ln Desc	Qty	Unit Issue	Unit Price	Ln Total Or Contract Amount
3	ELASTOMERIC BEARING PADS	18.00000	EA	1.000000	18.00

Comm Code	Manufacturer	Specification	Model #
30103619			

Commodity Line Comments: included

Extended Description:

B1 (14) = 1-13/16" HEIGHT BY 28" WIDTH BY 4 3/4" LENGTH
 B2 (4) = 1-13/16" HEIGHT BY 15 1/2" WIDTH BY 4 3/4" LENGTH

Line	Comm Ln Desc	Qty	Unit Issue	Unit Price	Ln Total Or Contract Amount
4	DEFORMED ANCHOR BOLTS	18.00000	EA	1.000000	18.00

Comm Code	Manufacturer	Specification	Model #
30103619			

Commodity Line Comments: included

Extended Description:

1" DIAMETER BY 2'-0" LENGTH

Line	Comm Ln Desc	Qty	Unit Issue	Unit Price	Ln Total Or Contract Amount
5	PREFORMED JOINT FILLER	176.00000	LF	1.000000	176.00

Comm Code	Manufacturer	Specification	Model #
30103619			

Commodity Line Comments: included

Extended Description:

1" THICK BY 33" WIDTH (56 LF)
 1-1/2" THICK BY 6" WIDTH (56 LF)
 1-1/2" THICK BY 4-3/4" WIDTH (14 LF)

Line	Comm Ln Desc	Qty	Unit Issue	Unit Price	Ln Total Or Contract Amount
6	POST TENSIONING BARS	5.00000	EA	1.000000	5.00

Comm Code	Manufacturer	Specification	Model #
30103619			

Commodity Line Comments: included

Extended Description:

1" DIAMETER BY 30'-6" LENGTH WITH HARDWARE, THREADED

ADDITIONAL INFORMATION

The West Virginia Purchasing Division is soliciting bids on behalf of Division of Highways to establish a contract for the one-time purchase of Prestressed Concrete Bridge Beams per the specifications and Terms & Conditions as attached hereto.

INVOICE TO		SHIP TO	
DIVISION OF HIGHWAYS DISTRICT FIVE		STATE OF WEST VIRGINIA JOBSITE - SEE SPECIFICATIONS	
PO BOX 99 BURLINGTON US	WV	No City US	WV

Line	Comm Ln Desc	Qty	Unit Issue	Unit Price	Total Price
1	EXTERIOR BEAMS	2.00000	EA	\$23,213.00	\$46,426.00

Comm Code	Manufacturer	Specification	Model #
30103619			

Extended Description:

33" DEPTH X 36" WIDTH BY 51'-6" OVERALL LEGTH (SHIP WITH GUARDRAIL & HARDWARE ATTACHED)

INVOICE TO		SHIP TO	
DIVISION OF HIGHWAYS DISTRICT FIVE		STATE OF WEST VIRGINIA JOBSITE - SEE SPECIFICATIONS	
PO BOX 99 BURLINGTON US	WV	No City US	WV

Line	Comm Ln Desc	Qty	Unit Issue	Unit Price	Total Price
2	INTERIOR BEAMS	7.00000	EA	\$23,213.00	\$162,491.00

Comm Code	Manufacturer	Specification	Model #
30103619			

Extended Description:

33" DEPTH X 336" WIDTH BY 61'-6" OVERALL LENGTH

INVOICE TO			SHIP TO		
DIVISION OF HIGHWAYS DISTRICT FIVE			STATE OF WEST VIRGINIA JOBSITE - SEE SPECIFICATIONS		
PO BOX 99 BURLINGTON US	WV		No City US	WV	

Line	Comm Ln Desc	Qty	Unit Issue	Unit Price	Total Price
3	ELASTOMERIC BEARING PADS	18.00000	EA	Included	Included

Comm Code	Manufacturer	Specification	Model #
30103619			

Extended Description:
 B1 (14) = 1-13/16" HEIGHT BY 28" WIDTH BY 4 3/4" LENGTH
 B2 (4) = 1-13/16" HEIGHT BY 15 1/2" WIDTH BY 4 3/4" LENGTH

INVOICE TO			SHIP TO		
DIVISION OF HIGHWAYS DISTRICT FIVE			STATE OF WEST VIRGINIA JOBSITE - SEE SPECIFICATIONS		
PO BOX 99 BURLINGTON US	WV		No City US	WV	

Line	Comm Ln Desc	Qty	Unit Issue	Unit Price	Total Price
4	DEFORMED ANCHOR BOLTS	18.00000	EA	Included	Included

Comm Code	Manufacturer	Specification	Model #
30103619			

Extended Description:
 1" DIAMETER BY 2'-0" LENGTH

INVOICE TO			SHIP TO		
DIVISION OF HIGHWAYS DISTRICT FIVE			STATE OF WEST VIRGINIA JOBSITE - SEE SPECIFICATIONS		
PO BOX 99 BURLINGTON US	WV		No City US	WV	

Line	Comm Ln Desc	Qty	Unit Issue	Unit Price	Total Price
5	PREFORMED JOINT FILLER	176.00000	LF	Included	Included

Comm Code	Manufacturer	Specification	Model #
30103619			

Extended Description:
1" THICK BY 33" WIDTH (56 LF)
1-1/2" THICK BY 6" WIDTH (56 LF)
1-1/2" THICK BY 4-3/4" WIDTH (14 LF)

INVOICE TO			SHIP TO		
DIVISION OF HIGHWAYS DISTRICT FIVE			STATE OF WEST VIRGINIA JOBSITE - SEE SPECIFICATIONS		
PO BOX 99 BURLINGTON US	WV		No City US	WV	

Line	Comm Ln Desc	Qty	Unit Issue	Unit Price	Total Price
6	POST TENSIONING BARS	5.00000	EA	Included	Included

Comm Code	Manufacturer	Specification	Model #
30103619			

Extended Description:
1" DIAMETER BY 30'-6" LENGTH WITH HARDWARE, THREADED

SCHEDULE OF EVENTS

Line	Event	Event Date
1	Technical Questions Due on September 30, 2021 at 10:00 AM	2021-09-30

INSTRUCTIONS TO VENDORS SUBMITTING BIDS

1. REVIEW DOCUMENTS THOROUGHLY: The attached documents contain a solicitation for bids. Please read these instructions and all documents attached in their entirety. These instructions provide critical information about requirements that if overlooked could lead to disqualification of a Vendor's bid. All bids must be submitted in accordance with the provisions contained in these instructions and the Solicitation. Failure to do so may result in disqualification of Vendor's bid.

2. MANDATORY TERMS: The Solicitation may contain mandatory provisions identified by the use of the words "must," "will," and "shall." Failure to comply with a mandatory term in the Solicitation will result in bid disqualification.

3. PREBID MEETING: The item identified below shall apply to this Solicitation.

A pre-bid meeting will not be held prior to bid opening

A **MANDATORY PRE-BID** meeting will be held at the following place and time:

All Vendors submitting a bid must attend the mandatory pre-bid meeting. Failure to attend the mandatory pre-bid meeting shall result in disqualification of the Vendor's bid. No one individual is permitted to represent more than one vendor at the pre-bid meeting. Any individual that does attempt to represent two or more vendors will be required to select one vendor to which the individual's attendance will be attributed. The vendors not selected will be deemed to have not attended the pre-bid meeting unless another individual attended on their behalf.

An attendance sheet provided at the pre-bid meeting shall serve as the official document verifying attendance. Any person attending the pre-bid meeting on behalf of a Vendor must list on the attendance sheet his or her name and the name of the Vendor he or she is representing.

Additionally, the person attending the pre-bid meeting should include the Vendor's E-Mail address, phone number, and Fax number on the attendance sheet. It is the Vendor's responsibility to locate the attendance sheet and provide the required information. Failure to complete the attendance sheet as required may result in disqualification of Vendor's bid.

All Vendors should arrive prior to the starting time for the pre-bid. Vendors who arrive after the starting time but prior to the end of the pre-bid will be permitted to sign in but are charged with knowing all matters discussed at the pre-bid.

Questions submitted at least five business days prior to a scheduled pre-bid will be discussed at the pre-bid meeting if possible. Any discussions or answers to questions at the pre-bid meeting
Revised 07/01/2021

are preliminary in nature and are non-binding. Official and binding answers to questions will be published in a written addendum to the Solicitation prior to bid opening.

4. VENDOR QUESTION DEADLINE: Vendors may submit questions relating to this Solicitation to the Purchasing Division. Questions must be submitted in writing. All questions must be submitted on or before the date listed below and to the address listed below to be considered. A written response will be published in a Solicitation addendum if a response is possible and appropriate. Non-written discussions, conversations, or questions and answers regarding this Solicitation are preliminary in nature and are nonbinding.

Submitted e-mails should have solicitation number in the subject line.

Question Submission Deadline: September 30, 2021 at 10:00 AM

Submit Questions to: Jessica Hovanec, Senior Buyer
2019 Washington Street, East
Charleston, WV 25305
Email: Jessica.L.Hovanec@wv.gov

5. VERBAL COMMUNICATION: Any verbal communication between the Vendor and any State personnel is not binding, including verbal communication at the mandatory pre-bid conference. Only information issued in writing and added to the Solicitation by an official written addendum by the Purchasing Division is binding.

6. BID SUBMISSION: All bids must be submitted electronically through wvOASIS or signed and delivered by the Vendor to the Purchasing Division at the address listed below on or before the date and time of the bid opening. Any bid received by the Purchasing Division staff is considered to be in the possession of the Purchasing Division and will not be returned for any reason. The Purchasing Division will not accept bids, modification of bids, or addendum acknowledgment forms via e-mail. Acceptable delivery methods include electronic submission via wvOASIS, hand delivery, delivery by courier, or facsimile.

The bid delivery address is:
Department of Administration, Purchasing Division
2019 Washington Street East
Charleston, WV 25305-0130

A bid that is not submitted electronically through wvOASIS should contain the information listed below on the face of the envelope or the bid may be rejected by the Purchasing Division.:

SEALED BID:
BUYER:
SOLICITATION NO.:
BID OPENING DATE:
BID OPENING TIME:
FAX NUMBER:

Revised 07/01/2021

The Purchasing Division may prohibit the submission of bids electronically through wvOASIS at its sole discretion. Such a prohibition will be contained and communicated in the wvOASIS system resulting in the Vendor's inability to submit bids through wvOASIS. Submission of a response to a Request for Proposal is not permitted in wvOASIS.

For Request For Proposal (“RFP”) Responses Only: In the event that Vendor is responding to a request for proposal, the Vendor shall submit one original technical and one original cost proposal prior to the bid opening date and time identified in Section 7 below, plus N/A convenience copies of each to the Purchasing Division at the address shown above. Additionally, the Vendor should clearly identify and segregate the cost proposal from the technical proposal in a separately sealed envelope.

7. BID OPENING: Bids submitted in response to this Solicitation will be opened at the location identified below on the date and time listed below. Delivery of a bid after the bid opening date and time will result in bid disqualification. For purposes of this Solicitation, a bid is considered delivered when confirmation of delivery is provided by wvOASIS (in the case of electronic submission) or when the bid is time stamped by the official Purchasing Division time clock (in the case of hand delivery).

Bid Opening Date and Time: October 12, 2021 at 1:30 PM

Bid Opening Location: Department of Administration, Purchasing Division
2019 Washington Street East
Charleston, WV 25305-0130

8. ADDENDUM ACKNOWLEDGEMENT: Changes or revisions to this Solicitation will be made by an official written addendum issued by the Purchasing Division. Vendor should acknowledge receipt of all addenda issued with this Solicitation by completing an Addendum Acknowledgment Form, a copy of which is included herewith. Failure to acknowledge addenda may result in bid disqualification. The addendum acknowledgement should be submitted with the bid to expedite document processing.

9. BID FORMATTING: Vendor should type or electronically enter the information onto its bid to prevent errors in the evaluation. Failure to type or electronically enter the information may result in bid disqualification.

10. ALTERNATE MODEL OR BRAND: Unless the box below is checked, any model, brand, or specification listed in this Solicitation establishes the acceptable level of quality only and is not intended to reflect a preference for, or in any way favor, a particular brand or vendor. Vendors may bid alternates to a listed model or brand provided that the alternate is at least equal to the model or brand and complies with the required specifications. The equality of any alternate being bid shall be determined by the State at its sole discretion. Any Vendor bidding an alternate model or brand should clearly identify the alternate items in its bid and should include manufacturer's specifications, industry literature, and/or any other relevant documentation demonstrating the equality of the alternate items. Failure to provide information for alternate items may be grounds for rejection of a Vendor's bid.

This Solicitation is based upon a standardized commodity established under W. Va. Code § 5A-3-61. Vendors are expected to bid the standardized commodity identified. Failure to bid the standardized commodity will result in your firm's bid being rejected.

11. EXCEPTIONS AND CLARIFICATIONS: The Solicitation contains the specifications that shall form the basis of a contractual agreement. Vendor shall clearly mark any exceptions, clarifications, or other proposed modifications in its bid. Exceptions to, clarifications of, or modifications of a requirement or term and condition of the Solicitation may result in bid disqualification.

12. COMMUNICATION LIMITATIONS: In accordance with West Virginia Code of State Rules §148-1-6.6, communication with the State of West Virginia or any of its employees regarding this Solicitation during the solicitation, bid, evaluation or award periods, except through the Purchasing Division, is strictly prohibited without prior Purchasing Division approval. Purchasing Division approval for such communication is implied for all agency delegated and exempt purchases.

13. REGISTRATION: Prior to Contract award, the apparent successful Vendor must be properly registered with the West Virginia Purchasing Division and must have paid the \$125 fee, if applicable.

14. UNIT PRICE: Unit prices shall prevail in cases of a discrepancy in the Vendor's bid.

15. PREFERENCE: Vendor Preference may be requested in purchases of motor vehicles or construction and maintenance equipment and machinery used in highway and other infrastructure projects. Any request for preference must be submitted in writing with the bid, must specifically identify the preference requested with reference to the applicable subsection of West Virginia Code § 5A-3-37, and must include with the bid any information necessary to evaluate and confirm the applicability of the requested preference. A request form to help facilitate the request can be found at:

<http://www.state.wv.us/admin/purchase/vrc/Venpref.pdf>.

15A. RECIPROCAL PREFERENCE: The State of West Virginia applies a reciprocal preference to all solicitations for commodities and printing in accordance with W. Va. Code § 5A-3-37(b). In effect, non-resident vendors receiving a preference in their home states, will see that same preference granted to West Virginia resident vendors bidding against them in West Virginia. Any request for reciprocal preference must include with the bid any information necessary to evaluate and confirm the applicability of the preference. A request form to help facilitate the request can be found at: <http://www.state.wv.us/admin/purchase/vrc/Venpref.pdf>.

16. SMALL, WOMEN-OWNED, OR MINORITY-OWNED BUSINESSES: For any solicitations publicly advertised for bid, in accordance with West Virginia Code §5A-3-37(a)(7) and W. Va. CSR § 148-22-9, any non-resident vendor certified as a small, women-owned, or minority-owned business under W. Va. CSR § 148-22-9 shall be provided the same preference made available to any resident vendor. Any non-resident small, women-owned, or minority-owned business must identify itself as such in writing, must submit that writing to the Purchasing Division with its bid, and must be properly certified under W. Va. CSR § 148-22-9 prior to contract award to receive the preferences made available to resident vendors. Preference

for a non-resident small, women-owned, or minority owned business shall be applied in accordance with W. Va. CSR § 148-22-9.

17. WAIVER OF MINOR IRREGULARITIES: The Director reserves the right to waive minor irregularities in bids or specifications in accordance with West Virginia Code of State Rules § 148-1-4.6.

18. ELECTRONIC FILE ACCESS RESTRICTIONS: Vendor must ensure that its submission in wvOASIS can be accessed and viewed by the Purchasing Division staff immediately upon bid opening. The Purchasing Division will consider any file that cannot be immediately accessed and viewed at the time of the bid opening (such as, encrypted files, password protected files, or incompatible files) to be blank or incomplete as context requires, and are therefore unacceptable. A vendor will not be permitted to unencrypt files, remove password protections, or resubmit documents after bid opening to make a file viewable if those documents are required with the bid. A Vendor may be required to provide document passwords or remove access restrictions to allow the Purchasing Division to print or electronically save documents provided that those documents are viewable by the Purchasing Division prior to obtaining the password or removing the access restriction.

19. NON-RESPONSIBLE: The Purchasing Division Director reserves the right to reject the bid of any vendor as Non-Responsible in accordance with W. Va. Code of State Rules § 148-1-5.3, when the Director determines that the vendor submitting the bid does not have the capability to fully perform or lacks the integrity and reliability to assure good-faith performance.”

20. ACCEPTANCE/REJECTION: The State may accept or reject any bid in whole, or in part in accordance with W. Va. Code of State Rules § 148-1-4.5. and § 148-1-6.4.b.”

21. YOUR SUBMISSION IS A PUBLIC DOCUMENT: Vendor’s entire response to the Solicitation and the resulting Contract are public documents. As public documents, they will be disclosed to the public following the bid/proposal opening or award of the contract, as required by the competitive bidding laws of West Virginia Code §§ 5A-3-1 et seq., 5-22-1 et seq., and 5G-1-1 et seq. and the Freedom of Information Act West Virginia Code §§ 29B-1-1 et seq.

DO NOT SUBMIT MATERIAL YOU CONSIDER TO BE CONFIDENTIAL, A TRADE SECRET, OR OTHERWISE NOT SUBJECT TO PUBLIC DISCLOSURE.

Submission of any bid, proposal, or other document to the Purchasing Division constitutes your explicit consent to the subsequent public disclosure of the bid, proposal, or document. The Purchasing Division will disclose any document labeled “confidential,” “proprietary,” “trade secret,” “private,” or labeled with any other claim against public disclosure of the documents, to include any “trade secrets” as defined by West Virginia Code § 47-22-1 et seq. All submissions are subject to public disclosure without notice.

22. INTERESTED PARTY DISCLOSURE: West Virginia Code § 6D-1-2 requires that the vendor submit to the Purchasing Division a disclosure of interested parties to the contract for all contracts with an actual or estimated value of at least \$1 million. That disclosure must occur on the form prescribed and approved by the WV Ethics Commission prior to contract award.

A copy of that form is included with this solicitation or can be obtained from the WV Ethics Commission. This requirement does not apply to publicly traded companies listed on a national or international stock exchange. A more detailed definition of interested parties can be obtained from the form referenced above.

23. WITH THE BID REQUIREMENTS: In instances where these specifications require documentation or other information with the bid, and a vendor fails to provide it with the bid, the Director of the Purchasing Division reserves the right to request those items after bid opening and prior to contract award pursuant to the authority to waive minor irregularities in bids or specifications under W. Va. CSR § 148-1-4.6. This authority does not apply to instances where state law mandates receipt with the bid.

24. E-MAIL NOTIFICATION OF AWARD: The Purchasing Division will attempt to provide bidders with e-mail notification of contract award when a solicitation that the bidder participated in has been awarded. For notification purposes, bidders must provide the Purchasing Division with a valid email address in the bid response. Bidders may also monitor wvOASIS or the Purchasing Division's website to determine when a contract has been awarded.

GENERAL TERMS AND CONDITIONS:

1. CONTRACTUAL AGREEMENT: Issuance of an Award Document signed by the Purchasing Division Director, or his designee, and approved as to form by the Attorney General's office constitutes acceptance by the State of this Contract made by and between the State of West Virginia and the Vendor. Vendor's signature on its bid, or on the Contract if the Contract is not the result of a bid solicitation, signifies Vendor's agreement to be bound by and accept the terms and conditions contained in this Contract.

2. DEFINITIONS: As used in this Solicitation/Contract, the following terms shall have the meanings attributed to them below. Additional definitions may be found in the specifications included with this Solicitation/Contract.

2.1. "Agency" or "Agencies" means the agency, board, commission, or other entity of the State of West Virginia that is identified on the first page of the Solicitation or any other public entity seeking to procure goods or services under this Contract.

2.2. "Bid" or "Proposal" means the vendors submitted response to this solicitation.

2.3. "Contract" means the binding agreement that is entered into between the State and the Vendor to provide the goods or services requested in the Solicitation.

2.4. "Director" means the Director of the West Virginia Department of Administration, Purchasing Division.

2.5. "Purchasing Division" means the West Virginia Department of Administration, Purchasing Division.

2.6. "Award Document" means the document signed by the Agency and the Purchasing Division, and approved as to form by the Attorney General, that identifies the Vendor as the contract holder.

2.7. "Solicitation" means the official notice of an opportunity to supply the State with goods or services that is published by the Purchasing Division.

2.8. "State" means the State of West Virginia and/or any of its agencies, commissions, boards, etc. as context requires.

2.9. "Vendor" or "Vendors" means any entity submitting a bid in response to the Solicitation, the entity that has been selected as the lowest responsible bidder, or the entity that has been awarded the Contract as context requires.

3. CONTRACT TERM; RENEWAL; EXTENSION: The term of this Contract shall be determined in accordance with the category that has been identified as applicable to this Contract below:

Term Contract

Initial Contract Term: This Contract becomes effective on _____ and the initial contract term extends until _____.

Renewal Term: This Contract may be renewed upon the mutual written consent of the Agency, and the Vendor, with approval of the Purchasing Division and the Attorney General's office (Attorney General approval is as to form only). Any request for renewal should be delivered to the Agency and then submitted to the Purchasing Division thirty (30) days prior to the expiration date of the initial contract term or appropriate renewal term. A Contract renewal shall be in accordance with the terms and conditions of the original contract. Unless otherwise specified below, renewal of this Contract is limited to _____ successive one (1) year periods or multiple renewal periods of less than one year, provided that the multiple renewal periods do not exceed the total number of months available in all renewal years combined. Automatic renewal of this Contract is prohibited. Renewals must be approved by the Vendor, Agency, Purchasing Division and Attorney General's office (Attorney General approval is as to form only)

Alternate Renewal Term – This contract may be renewed for _____ successive _____ year periods or shorter periods provided that they do not exceed the total number of months contained in all available renewals. Automatic renewal of this Contract is prohibited. Renewals must be approved by the Vendor, Agency, Purchasing Division and Attorney General's office (Attorney General approval is as to form only)

Delivery Order Limitations: In the event that this contract permits delivery orders, a delivery order may only be issued during the time this Contract is in effect. Any delivery order issued within one year of the expiration of this Contract shall be effective for one year from the date the delivery order is issued. No delivery order may be extended beyond one year after this Contract has expired.

Fixed Period Contract: This Contract becomes effective upon Vendor's receipt of the notice to proceed and must be completed within _____ days.

Fixed Period Contract with Renewals: This Contract becomes effective upon Vendor's receipt of the notice to proceed and part of the Contract more fully described in the attached specifications must be completed within _____ days. Upon completion of the work covered by the preceding sentence, the vendor agrees that maintenance, monitoring, or warranty services will be provided for _____ year(s) thereafter.

One Time Purchase: The term of this Contract shall run from the issuance of the Award Document until all of the goods contracted for have been delivered, but in no event will this Contract extend for more than one fiscal year.

Other: See attached _____
Revised 07/01/2021

4. AUTHORITY TO PROCEED: Vendor is authorized to begin performance of this contract on the date of encumbrance listed on the front page of the Award Document unless either the box for “Fixed Period Contract” or “Fixed Period Contract with Renewals” has been checked in Section 3 above. If either “Fixed Period Contract” or “Fixed Period Contract with Renewals” has been checked, Vendor must not begin work until it receives a separate notice to proceed from the State. The notice to proceed will then be incorporated into the Contract via change order to memorialize the official date that work commenced.

5. QUANTITIES: The quantities required under this Contract shall be determined in accordance with the category that has been identified as applicable to this Contract below.

Open End Contract: Quantities listed in this Solicitation/Award Document are approximations only, based on estimates supplied by the Agency. It is understood and agreed that the Contract shall cover the quantities actually ordered for delivery during the term of the Contract, whether more or less than the quantities shown.

Service: The scope of the service to be provided will be more clearly defined in the specifications included herewith.

Combined Service and Goods: The scope of the service and deliverable goods to be provided will be more clearly defined in the specifications included herewith.

One Time Purchase: This Contract is for the purchase of a set quantity of goods that are identified in the specifications included herewith. Once those items have been delivered, no additional goods may be procured under this Contract without an appropriate change order approved by the Vendor, Agency, Purchasing Division, and Attorney General’s office.

6. EMERGENCY PURCHASES: The Purchasing Division Director may authorize the Agency to purchase goods or services in the open market that Vendor would otherwise provide under this Contract if those goods or services are for immediate or expedited delivery in an emergency. Emergencies shall include, but are not limited to, delays in transportation or an unanticipated increase in the volume of work. An emergency purchase in the open market, approved by the Purchasing Division Director, shall not constitute of breach of this Contract and shall not entitle the Vendor to any form of compensation or damages. This provision does not excuse the State from fulfilling its obligations under a One Time Purchase contract.

7. REQUIRED DOCUMENTS: All of the items checked below must be provided to the Purchasing Division by the Vendor as specified below.

BID BOND (Construction Only): Pursuant to the requirements contained in W. Va. Code § 5-22-1(c), All Vendors submitting a bid on a construction project shall furnish a valid bid bond in the amount of five percent (5%) of the total amount of the bid protecting the State of West Virginia. The bid bond must be submitted with the bid.

PERFORMANCE BOND: The apparent successful Vendor shall provide a performance bond in the amount of 100% of the contract. The performance bond must be received by the Purchasing Division prior to Contract award.

LABOR/MATERIAL PAYMENT BOND: The apparent successful Vendor shall provide a labor/material payment bond in the amount of 100% of the Contract value. The labor/material payment bond must be delivered to the Purchasing Division prior to Contract award.

In lieu of the Bid Bond, Performance Bond, and Labor/Material Payment Bond, the Vendor may provide certified checks, cashier's checks, or irrevocable letters of credit. Any certified check, cashier's check, or irrevocable letter of credit provided in lieu of a bond must be of the same amount and delivered on the same schedule as the bond it replaces. A letter of credit submitted in lieu of a performance and labor/material payment bond will only be allowed for projects under \$100,000. Personal or business checks are not acceptable. Notwithstanding the foregoing, West Virginia Code § 5-22-1 (d) mandates that a vendor provide a performance and labor/material payment bond for construction projects. Accordingly, substitutions for the performance and labor/material payment bonds for construction projects is not permitted.

MAINTENANCE BOND: The apparent successful Vendor shall provide a two (2) year maintenance bond covering the roofing system. The maintenance bond must be issued and delivered to the Purchasing Division prior to Contract award.

LICENSE(S) / CERTIFICATIONS / PERMITS: In addition to anything required under the Section of the General Terms and Conditions entitled Licensing, the apparent successful Vendor shall furnish proof of the following licenses, certifications, and/or permits upon request and in a form acceptable to the State. The request may be prior to or after contract award at the State's sole discretion.

The apparent successful Vendor shall also furnish proof of any additional licenses or certifications contained in the specifications regardless of whether or not that requirement is listed above.

8. INSURANCE: The apparent successful Vendor shall furnish proof of the insurance identified by a checkmark below and must include the State as an additional insured on each policy prior to Contract award. The insurance coverages identified below must be maintained throughout the life of this contract. Thirty (30) days prior to the expiration of the insurance policies, Vendor shall provide the Agency with proof that the insurance mandated herein has been continued. Vendor must also provide Agency with immediate notice of any changes in its insurance policies, including but not limited to, policy cancelation, policy reduction, or change in insurers. The apparent successful Vendor shall also furnish proof of any additional insurance requirements contained in the specifications prior to Contract award regardless of whether that insurance requirement is listed in this section.

Vendor must maintain:

Commercial General Liability Insurance in at least an amount of: \$1,000,000 per occurrence.

Automobile Liability Insurance in at least an amount of: \$100,000 per occurrence.

Professional/Malpractice/Errors and Omission Insurance in at least an amount of: _____ per occurrence. Notwithstanding the forgoing, Vendor's are not required to list the State as an additional insured for this type of policy.

Commercial Crime and Third Party Fidelity Insurance in an amount of: _____ per occurrence.

Cyber Liability Insurance in an amount of: _____ per occurrence.

Builders Risk Insurance in an amount equal to 100% of the amount of the Contract.

Pollution Insurance in an amount of: _____ per occurrence.

Aircraft Liability in an amount of: _____ per occurrence.

Notwithstanding anything contained in this section to the contrary, the Director of the Purchasing Division reserves the right to waive the requirement that the State be named as an additional insured on one or more of the Vendor's insurance policies if the Director finds that doing so is in the State's best interest.

9. WORKERS' COMPENSATION INSURANCE: Vendor shall comply with laws relating to workers compensation, shall maintain workers' compensation insurance when required, and shall furnish proof of workers' compensation insurance upon request.

10. [Reserved]

11. LIQUIDATED DAMAGES: This clause shall in no way be considered exclusive and shall not limit the State or Agency's right to pursue any other available remedy. Vendor shall pay liquidated damages in the amount specified below or as described in the specifications:

_____ for _____.

Liquidated Damages Contained in the Specifications.

Liquidated Damages Are Not Included in this Contract.

12. ACCEPTANCE: Vendor's signature on its bid, or on the certification and signature page, constitutes an offer to the State that cannot be unilaterally withdrawn, signifies that the product or service proposed by vendor meets the mandatory requirements contained in the Solicitation for that product or service, unless otherwise indicated, and signifies acceptance of the terms and conditions contained in the Solicitation unless otherwise indicated.

13. PRICING: The pricing set forth herein is firm for the life of the Contract, unless specified elsewhere within this Solicitation/Contract by the State. A Vendor's inclusion of price adjustment provisions in its bid, without an express authorization from the State in the Solicitation to do so, may result in bid disqualification. Notwithstanding the foregoing, Vendor must extend any publicly advertised sale price to the State and invoice at the lower of the contract price or the publicly advertised sale price.

14. PAYMENT IN ARREARS: Payments for goods/services will be made in arrears only upon receipt of a proper invoice, detailing the goods/services provided or receipt of the goods/services, whichever is later. Notwithstanding the foregoing, payments for software maintenance, licenses, or subscriptions may be paid annually in advance.

15. PAYMENT METHODS: Vendor must accept payment by electronic funds transfer and P-Card. (The State of West Virginia's Purchasing Card program, administered under contract by a banking institution, processes payment for goods and services through state designated credit cards.)

16. TAXES: The Vendor shall pay any applicable sales, use, personal property or any other taxes arising out of this Contract and the transactions contemplated thereby. The State of West Virginia is exempt from federal and state taxes and will not pay or reimburse such taxes.

17. ADDITIONAL FEES: Vendor is not permitted to charge additional fees or assess additional charges that were not either expressly provided for in the solicitation published by the State of West Virginia, included in the Contract, or included in the unit price or lump sum bid amount that Vendor is required by the solicitation to provide. Including such fees or charges as notes to the solicitation may result in rejection of vendor's bid. Requesting such fees or charges be paid after the contract has been awarded may result in cancellation of the contract.

18. FUNDING: This Contract shall continue for the term stated herein, contingent upon funds being appropriated by the Legislature or otherwise being made available. In the event funds are not appropriated or otherwise made available, this Contract becomes void and of no effect beginning on July 1 of the fiscal year for which funding has not been appropriated or otherwise made available. If that occurs, the State may notify the Vendor that an alternative source of funding has been obtained and thereby avoid the automatic termination. Non-appropriation or non-funding shall not be considered an event of default.

19. CANCELLATION: The Purchasing Division Director reserves the right to cancel this Contract immediately upon written notice to the vendor if the materials or workmanship supplied do not conform to the specifications contained in the Contract. The Purchasing Division Director may also cancel any purchase or Contract upon 30 days written notice to the Vendor in accordance with West Virginia Code of State Rules § 148-1-5.2.b.

20. TIME: Time is of the essence regarding all matters of time and performance in this Contract.

21. APPLICABLE LAW: This Contract is governed by and interpreted under West Virginia law without giving effect to its choice of law principles. Any information provided in specification manuals, or any other source, verbal or written, which contradicts or violates the West Virginia Constitution, West Virginia Code, or West Virginia Code of State Rules is void and of no effect.

22. COMPLIANCE WITH LAWS: Vendor shall comply with all applicable federal, state, and local laws, regulations and ordinances. By submitting a bid, Vendor acknowledges that it has reviewed, understands, and will comply with all applicable laws, regulations, and ordinances.

SUBCONTRACTOR COMPLIANCE: Vendor shall notify all subcontractors providing commodities or services related to this Contract that as subcontractors, they too are required to comply with all applicable laws, regulations, and ordinances. Notification under this provision must occur prior to the performance of any work under the contract by the subcontractor.

23. ARBITRATION: Any references made to arbitration contained in this Contract, Vendor's bid, or in any American Institute of Architects documents pertaining to this Contract are hereby deleted, void, and of no effect.

24. MODIFICATIONS: This writing is the parties' final expression of intent. Notwithstanding anything contained in this Contract to the contrary no modification of this Contract shall be binding without mutual written consent of the Agency, and the Vendor, with approval of the Purchasing Division and the Attorney General's office (Attorney General approval is as to form only). Any change to existing contracts that adds work or changes contract cost, and were not included in the original contract, must be approved by the Purchasing Division and the Attorney General's Office (as to form) prior to the implementation of the change or commencement of work affected by the change.

25. WAIVER: The failure of either party to insist upon a strict performance of any of the terms or provision of this Contract, or to exercise any option, right, or remedy herein contained, shall not be construed as a waiver or a relinquishment for the future of such term, provision, option, right, or remedy, but the same shall continue in full force and effect. Any waiver must be expressly stated in writing and signed by the waiving party.

26. SUBSEQUENT FORMS: The terms and conditions contained in this Contract shall supersede any and all subsequent terms and conditions which may appear on any form documents submitted by Vendor to the Agency or Purchasing Division such as price lists, order forms, invoices, sales agreements, or maintenance agreements, and includes internet websites or other electronic documents. Acceptance or use of Vendor's forms does not constitute acceptance of the terms and conditions contained thereon.

27. ASSIGNMENT: Neither this Contract nor any monies due, or to become due hereunder, may be assigned by the Vendor without the express written consent of the Agency, the Purchasing Division, the Attorney General's office (as to form only), and any other government agency or office that may be required to approve such assignments.

28. WARRANTY: The Vendor expressly warrants that the goods and/or services covered by this Contract will: (a) conform to the specifications, drawings, samples, or other description furnished or specified by the Agency; (b) be merchantable and fit for the purpose intended; and (c) be free from defect in material and workmanship.

29. STATE EMPLOYEES: State employees are not permitted to utilize this Contract for personal use and the Vendor is prohibited from permitting or facilitating the same.

30. PRIVACY, SECURITY, AND CONFIDENTIALITY: The Vendor agrees that it will not disclose to anyone, directly or indirectly, any such personally identifiable information or other confidential information gained from the Agency, unless the individual who is the subject of the information consents to the disclosure in writing or the disclosure is made pursuant to the Agency's policies, procedures, and rules. Vendor further agrees to comply with the Confidentiality Policies and Information Security Accountability Requirements, set forth in <http://www.state.wv.us/admin/purchase/privacy/default.html>.

31. YOUR SUBMISSION IS A PUBLIC DOCUMENT: Vendor's entire response to the Solicitation and the resulting Contract are public documents. As public documents, they will be disclosed to the public following the bid/proposal opening or award of the contract, as required by the competitive bidding laws of West Virginia Code §§ 5A-3-1 et seq., 5-22-1 et seq., and 5G-1-1 et seq. and the Freedom of Information Act West Virginia Code §§ 29B-1-1 et seq.

DO NOT SUBMIT MATERIAL YOU CONSIDER TO BE CONFIDENTIAL, A TRADE SECRET, OR OTHERWISE NOT SUBJECT TO PUBLIC DISCLOSURE.

Submission of any bid, proposal, or other document to the Purchasing Division constitutes your explicit consent to the subsequent public disclosure of the bid, proposal, or document. The Purchasing Division will disclose any document labeled "confidential," "proprietary," "trade secret," "private," or labeled with any other claim against public disclosure of the documents, to include any "trade secrets" as defined by West Virginia Code § 47-22-1 et seq. All submissions are subject to public disclosure without notice.

32. LICENSING: In accordance with West Virginia Code of State Rules § 148-1-6.1.e, Vendor must be licensed and in good standing in accordance with any and all state and local laws and requirements by any state or local agency of West Virginia, including, but not limited to, the West Virginia Secretary of State's Office, the West Virginia Tax Department, West Virginia Insurance Commission, or any other state agency or political subdivision. Obligations related to political subdivisions may include, but are not limited to, business licensing, business and occupation taxes, inspection compliance, permitting, etc. Upon request, the Vendor must provide all necessary releases to obtain information to enable the Purchasing Division Director or the Agency to verify that the Vendor is licensed and in good standing with the above entities.

SUBCONTRACTOR COMPLIANCE: Vendor shall notify all subcontractors providing commodities or services related to this Contract that as subcontractors, they too are required to be licensed, in good standing, and up-to-date on all state and local obligations as described in this section. Obligations related to political subdivisions may include, but are not limited to, business licensing, business and occupation taxes, inspection compliance, permitting, etc. Notification under this provision must occur prior to the performance of any work under the contract by the subcontractor.

33. ANTITRUST: In submitting a bid to, signing a contract with, or accepting a Award Document from any agency of the State of West Virginia, the Vendor agrees to convey, sell, assign, or transfer to the State of West Virginia all rights, title, and interest in and to all causes of action it may now or hereafter acquire under the antitrust laws of the United States and the State of West Virginia for price fixing and/or unreasonable restraints of trade relating to the particular commodities or services purchased or acquired by the State of West Virginia. Such assignment shall be made and become effective at the time the purchasing agency tenders the initial payment to Vendor.

34. VENDOR CERTIFICATIONS: By signing its bid or entering into this Contract, Vendor certifies (1) that its bid or offer was made without prior understanding, agreement, or connection with any corporation, firm, limited liability company, partnership, person or entity submitting a bid or offer for the same material, supplies, equipment or services; (2) that its bid or offer is in all respects fair and without collusion or fraud; (3) that this Contract is accepted or entered into without any prior understanding, agreement, or connection to any other entity that could be considered a violation of law; and (4) that it has reviewed this Solicitation in its entirety; understands the requirements, terms and conditions, and other information contained herein.

Vendor's signature on its bid or offer also affirms that neither it nor its representatives have any interest, nor shall acquire any interest, direct or indirect, which would compromise the performance of its services hereunder. Any such interests shall be promptly presented in detail to the Agency. The individual signing this bid or offer on behalf of Vendor certifies that he or she is authorized by the Vendor to execute this bid or offer or any documents related thereto on Vendor's behalf; that he or she is authorized to bind the Vendor in a contractual relationship; and that, to the best of his or her knowledge, the Vendor has properly registered with any State agency that may require registration.

35. VENDOR RELATIONSHIP: The relationship of the Vendor to the State shall be that of an independent contractor and no principal-agent relationship or employer-employee relationship is contemplated or created by this Contract. The Vendor as an independent contractor is solely liable for the acts and omissions of its employees and agents. Vendor shall be responsible for selecting, supervising, and compensating any and all individuals employed pursuant to the terms of this Solicitation and resulting contract. Neither the Vendor, nor any employees or subcontractors of the Vendor, shall be deemed to be employees of the State for any purpose whatsoever. Vendor shall be exclusively responsible for payment of employees and contractors for all wages and salaries, taxes, withholding payments, penalties, fees, fringe benefits, professional liability insurance premiums, contributions to insurance and pension, or other deferred compensation plans, including but not limited to, Workers' Compensation and Social Security obligations, licensing fees, etc. and the filing of all necessary documents, forms, and returns pertinent to all of the foregoing.

Vendor shall hold harmless the State, and shall provide the State and Agency with a defense against any and all claims including, but not limited to, the foregoing payments, withholdings, contributions, taxes, Social Security taxes, and employer income tax returns.

36. INDEMNIFICATION: The Vendor agrees to indemnify, defend, and hold harmless the State and the Agency, their officers, and employees from and against: (1) Any claims or losses for services rendered by any subcontractor, person, or firm performing or supplying services, materials, or supplies in connection with the performance of the Contract; (2) Any claims or losses resulting to any person or entity injured or damaged by the Vendor, its officers, employees, or subcontractors by the publication, translation, reproduction, delivery, performance, use, or disposition of any data used under the Contract in a manner not authorized by the Contract, or by Federal or State statutes or regulations; and (3) Any failure of the Vendor, its officers, employees, or subcontractors to observe State and Federal laws including, but not limited to, labor and wage and hour laws.

37. PURCHASING AFFIDAVIT: In accordance with West Virginia Code §§ 5A-3-10a and 5-22-1(i), the State is prohibited from awarding a contract to any bidder that owes a debt to the State or a political subdivision of the State, Vendors are required to sign, notarize, and submit the Purchasing Affidavit to the Purchasing Division affirming under oath that it is not in default on any monetary obligation owed to the state or a political subdivision of the state.

38. CONFLICT OF INTEREST: Vendor, its officers or members or employees, shall not presently have or acquire an interest, direct or indirect, which would conflict with or compromise the performance of its obligations hereunder. Vendor shall periodically inquire of its officers, members and employees to ensure that a conflict of interest does not arise. Any conflict of interest discovered shall be promptly presented in detail to the Agency.

39. REPORTS: Vendor shall provide the Agency and/or the Purchasing Division with the following reports identified by a checked box below:

Such reports as the Agency and/or the Purchasing Division may request. Requested reports may include, but are not limited to, quantities purchased, agencies utilizing the contract, total contract expenditures by agency, etc.

Quarterly reports detailing the total quantity of purchases in units and dollars, along with a listing of purchases by agency. Quarterly reports should be delivered to the Purchasing Division via email at purchasing.division@wv.gov.

40. BACKGROUND CHECK: In accordance with W. Va. Code § 15-2D-3, the State reserves the right to prohibit a service provider's employees from accessing sensitive or critical information or to be present at the Capitol complex based upon results addressed from a criminal background check. Service providers should contact the West Virginia Division of Protective Services by phone at (304) 558-9911 for more information.

41. PREFERENCE FOR USE OF DOMESTIC STEEL PRODUCTS: Except when authorized by the Director of the Purchasing Division pursuant to W. Va. Code § 5A-3-56, no contractor may use or supply steel products for a State Contract Project other than those steel products made in the United States. A contractor who uses steel products in violation of this section may be subject to civil penalties pursuant to W. Va. Code § 5A-3-56. As used in this section:

- a. "State Contract Project" means any erection or construction of, or any addition to, alteration of or other improvement to any building or structure, including, but not limited to, roads or highways, or the installation of any heating or cooling or ventilating plants or other equipment, or the supply of and materials for such projects, pursuant to a contract with the State of West Virginia for which bids were solicited on or after June 6, 2001.
- b. "Steel Products" means products rolled, formed, shaped, drawn, extruded, forged, cast, fabricated or otherwise similarly processed, or processed by a combination of two or more or such operations, from steel made by the open heath, basic oxygen, electric furnace, Bessemer or other steel making process.
- c. The Purchasing Division Director may, in writing, authorize the use of foreign steel products if:

1. The cost for each contract item used does not exceed one tenth of one percent (.1%) of the total contract cost or two thousand five hundred dollars (\$2,500.00), whichever is greater. For the purposes of this section, the cost is the value of the steel product as delivered to the project; or
2. The Director of the Purchasing Division determines that specified steel materials are not produced in the United States in sufficient quantity or otherwise are not reasonably available to meet contract requirements.

42. PREFERENCE FOR USE OF DOMESTIC ALUMINUM, GLASS, AND STEEL: In Accordance with W. Va. Code § 5-19-1 et seq., and W. Va. CSR § 148-10-1 et seq., for every contract or subcontract, subject to the limitations contained herein, for the construction, reconstruction, alteration, repair, improvement or maintenance of public works or for the purchase of any item of machinery or equipment to be used at sites of public works, only domestic aluminum, glass or steel products shall be supplied unless the spending officer determines, in writing, after the receipt of offers or bids, (1) that the cost of domestic aluminum, glass or steel products is unreasonable or inconsistent with the public interest of the State of West Virginia, (2) that domestic aluminum, glass or steel products are not produced in sufficient quantities to meet the contract requirements, or (3) the available domestic aluminum, glass, or steel do not meet the contract specifications. This provision only applies to public works contracts awarded in an amount more than fifty thousand dollars (\$50,000) or public works contracts that require more than ten thousand pounds of steel products.

The cost of domestic aluminum, glass, or steel products may be unreasonable if the cost is more than twenty percent (20%) of the bid or offered price for foreign made aluminum, glass, or steel products. If the domestic aluminum, glass or steel products to be supplied or produced in a “substantial labor surplus area”, as defined by the United States Department of Labor, the cost of domestic aluminum, glass, or steel products may be unreasonable if the cost is more than thirty percent (30%) of the bid or offered price for foreign made aluminum, glass, or steel products. This preference shall be applied to an item of machinery or equipment, as indicated above, when the item is a single unit of equipment or machinery manufactured primarily of aluminum, glass or steel, is part of a public works contract and has the sole purpose or of being a permanent part of a single public works project. This provision does not apply to equipment or machinery purchased by a spending unit for use by that spending unit and not as part of a single public works project.

All bids and offers including domestic aluminum, glass or steel products that exceed bid or offer prices including foreign aluminum, glass or steel products after application of the preferences provided in this provision may be reduced to a price equal to or lower than the lowest bid or offer price for foreign aluminum, glass or steel products plus the applicable preference. If the reduced bid or offer prices are made in writing and supersede the prior bid or offer prices, all bids or offers, including the reduced bid or offer prices, will be reevaluated in accordance with this rule.

43. INTERESTED PARTY SUPPLEMENTAL DISCLOSURE: W. Va. Code § 6D-1-2 requires that for contracts with an actual or estimated value of at least \$1 million, the vendor must submit to the Agency a supplemental disclosure of interested parties reflecting any new or differing interested parties to the contract, which were not included in the original pre-award interested party disclosure, within 30 days following the completion or termination of the contract. A copy of that form is included with this solicitation or can be obtained from the WV Ethics Commission. This requirement does not apply to publicly traded companies listed on a national or international stock exchange. A more detailed definition of interested parties can be obtained from the form referenced above.

44. PROHIBITION AGAINST USED OR REFURBISHED: Unless expressly permitted in the solicitation published by the State, Vendor must provide new, unused commodities, and is prohibited from supplying used or refurbished commodities, in fulfilling its responsibilities under this Contract.

45. VOID CONTRACT CLAUSES – This Contract is subject to the provisions of West Virginia Code § 5A-3-62, which automatically voids certain contract clauses that violate State law.

DESIGNATED CONTACT: Vendor appoints the individual identified in this Section as the Contract Administrator and the initial point of contact for matters relating to this Contract.

Shaji Habib Sales Manager

(Name, Title) See above

(Printed Name and Title)
1349 S. International Parwkay, Suite 2411, Lake Mary, FL 32746

(Address)
407-359-2373

(Phone Number) / (Fax Number)
tii@tii-usa.com

(email address)

CERTIFICATION AND SIGNATURE: By signing below, or submitting documentation through wvOASIS, I certify that: I have reviewed this Solicitation in its entirety; that I understand the requirements, terms and conditions, and other information contained herein; that this bid, offer or proposal constitutes an offer to the State that cannot be unilaterally withdrawn; that the product or service proposed meets the mandatory requirements contained in the Solicitation for that product or service, unless otherwise stated herein; that the Vendor accepts the terms and conditions contained in the Solicitation, unless otherwise stated herein; that I am submitting this bid, offer or proposal for review and consideration; that I am authorized by the vendor to execute and submit this bid, offer, or proposal, or any documents related thereto on vendor's behalf; that I am authorized to bind the vendor in a contractual relationship; and that to the best of my knowledge, the vendor has properly registered with any State agency that may require registration.

By signing below, I further certify that I understand this Contract is subject to the provisions of West Virginia Code § 5A-3-62, which automatically voids certain contract clauses that violate State law.

Technology International, Inc.

(Company)
Shaji Habib Shaji Habib - Sales Manager

(Authorized Signature) (Representative Name, Title)
See above

(Printed Name and Title of Authorized Representative)
10/12/21

(Date)
407-359-2373

(Phone Number) (Fax Number)

REQUEST FOR QUOTATION
05220081- PRESTRESSED CONCRETE BEAMS

SPECIFICATIONS

1. **PURPOSE AND SCOPE:** The West Virginia Purchasing Division is soliciting bids on behalf of Division of Highways to establish a contract for the one-time purchase of Prestressed Concrete Bridge Beams.

2. **DEFINITIONS:** The terms listed below shall have the meanings assigned to them below. Additional definitions can be found in section 2 of the General Terms and Conditions.
 - 2.1 **“Contract Item”** means Prestressed Concrete Bridge Beams as more fully described by these specifications.

 - 2.2 **“Pricing Page”** means the pages, contained in wvOASIS or attached as Exhibit A, upon which Vendor should list its proposed price for the Contract Items.

 - 2.3 **“Solicitation”** means the official notice of an opportunity to supply the State with goods or services that is published by the Purchasing Division.

3. **GENERAL REQUIREMENTS:**
 - 3.1 **Mandatory Contract Item Requirements:** Contract Item must meet or exceed the mandatory requirements listed below.
 - 3.1.1 **Contract Item #1 – Exterior Beams**
 - 3.1.1.1 Exterior Beams must be 33” depth by 36” width by 51’-6” overall length. (50’-0” c-c bearing anchor bolt holes).

 - 3.1.1.2 Exterior beams must be compatible with all guardrail, inserts, guardrail posts, and guardrail attached.

REQUEST FOR QUOTATION
05220081- PRESTRESSED CONCRETE BEAMS

3.1.2 Contract Item #2 – Interior Beams

3.1.2.1 Interior beams must be 33” depth by 36” width by 51’-6” overall length. (50’-0” c-c bearing anchor bolt holes).

3.1.3 Contract Item #3 – Elastomeric Bearing Pads

3.1.3.1 Elastomeric Bearing Pads must be: B1 =1-13/16” height by 28” wide by 4-3/4” length. B2 =1-13/16” height by 15-1/2” wide by 4-3/4” length.

3.1.4 Contract Item #4 – Deformed Anchor Bolts

3.1.4.1 Deformed Anchor Bolts must be No. 8 Grade 60 bar, 1” diameter by 2’-0” length.

3.1.5 Contract Item #5 – Preformed Joint Filler

3.1.5.1 Preformed Joint Filler must be 1” thick by 33” width, 1-1/2” thick by 6” width, and 1-1/2” thick by 4-3/4” width.

3.1.6 Contract Item #6 – Post Tensioning Bars

3.1.6.1 Post Tensioning Bars must be 1” diameter by 30’-6” length.

3.1.6.2 Post Tensioning Bars must be threaded, and supplied with all plates, hex nuts, and other hardware as required in plans.

3.2 Mandatory Requirements: Vendor must meet or exceed the mandatory requirements as shown below:

3.2.1 The West Virginia Department of Transportation, Division of Highways Standard Specifications Road and Bridges, adopted 2017 as modified by any Supplemental Specifications shall apply to the administration of this requisition.

All items supplied under this requisition shall meet the requirements of the “West Virginia Department of Transportation, Division of Highways Standard Specifications Road and Bridges, adopted 2017, as modified by the most recent Supplemental Specifications.

REQUEST FOR QUOTATION
05220081- PRESTRESSED CONCRETE BEAMS

3.2.2 All Prestressed Concrete Box Shaped Beams shall be manufactured in accordance with the attached West Virginia Department of Transportation, Division of Highways **Standard Bridge Plan Sheets dated 7/07** for State Project No. S319-17/1-3.29 as follows:

<u>Item Description</u>	<u>Standard Sheet No</u>	<u>Revision Date</u>
33" Box Beam	BR-B33A & BR-B33B	7/07
Beam Details	3000GN1, 3000GN2, 3000FR3, 3000MB2 & 3000MB3	8/20
Post-Tensioning/ Lifting Details	3000MB1	8/20

3.2.3 Alternates to the above Division of Highways standards will be permitted if approved by the District Five Bridge Engineer. Alternate designs must be submitted for approval based on the Design Data Charts provided as a part of this requisition and must be approved prior to award of this requisition purchase order. In addition to the design criteria contained on the Division of Highways Standard Bridge Plan Sheets referenced above, all alternate designs must be based on the following criteria:

3.2.3.1 Two lane bridge with a deck width of 27'-6" out to out and roadway width of 27'-6" rail to rail.

3.2.3.2 Guardrail superimposed dead load of 30 pounds per linear foot assumed to be applied equally to all beams.

3.2.3.3 Future wearing surface superimposed dead load of 50 psf applied equally to all beams.

3.2.3.4 Live loading of HL-93.

3.2.4 The terms "Contractor" and "Vendor" used in the above specifications or this requisition are interchangeable. Contractor shall mean Vendor and Vendor shall mean Contractor.

3.2.5 West Virginia Department of Transportation, Division of Highways Standard Specifications Road and Bridges, adopted 2017 and any Supplemental Specifications may be obtained from:

REQUEST FOR QUOTATION
05220081- PRESTRESSED CONCRETE BEAMS

http://www.transportation.wv.gov/highways/contractadmin/specifications/2017StandSpec/Documents/2017_Standard.pdf

West Virginia Department of Transportation, Division of Highways Standard Bridge Plan Sheets may be obtained from:

<http://www.transportation.wv.gov/highways/engineering/StandardDetails/Vol3/1999SD3.pdf>

3.2.6 Cracks developing in a beam may be cause for rejection of the beam. Cracks that are not detrimental to the structural integrity of the beam, as determined by the Division of Highways, may be accepted under the following conditions:

3.2.6.1 Cracks of 0.004 inch or less shall be treated with a coat of a Division of Highways approved concrete sealer.

3.2.6.2 Cracks of more than 0.004 inch shall be treated with a second coat of a Division of Highways approved concrete sealer, or epoxy injected.

All concrete sealer and epoxy injection required for acceptance shall be performed at no additional cost to the Division of Highways

4. CONTRACT AWARD:

4.1 Contract Award: The Contract is intended to provide Agencies with a purchase price for the Contract Items. The Contract shall be awarded to the Vendor that provides the Contract Items meeting the required specifications for the lowest overall total cost as shown on the Pricing Pages.

4.2 Pricing Page: Vendor should complete the Pricing Page by filling in the Unit Price for each item, the Amount for the specified Quantity for that item, and the Total Amount for all items. Vendor should complete the Pricing Page in full as failure to complete the Pricing Page in its entirety may result in Vendor's bid being disqualified.

REQUEST FOR QUOTATION
05220081- PRESTRESSED CONCRETE BEAMS

Vendor should type or electronically enter the information into the Pricing Page to prevent errors in the evaluation.

5. PAYMENT:

5.1 Payment: Vendor shall accept payment in accordance with the payment procedures of the State of West Virginia.

6. DELIVERY AND RETURN:

6.1 Shipment and Delivery: Vendor shall ship the Contract Items immediately after being awarded this Contract and receiving a purchase order or notice to proceed. Vendor shall deliver the Contract Items within 60 working days after receiving a purchase order or notice to proceed. Contract Items must be delivered to Agency at the Project Location.

6.2 Late Delivery: The Agency placing the order under this Contract must be notified in writing if the shipment of the Contract Items will be delayed for any reason. Any delay in delivery that could cause harm to an Agency will be grounds for cancellation of the Contract, and/or obtaining the Contract Items from a third party.

Any Agency seeking to obtain the Contract Items from a third party under this provision must first obtain approval of the Purchasing Division.

6.3 Delivery Payment/Risk of Loss: Vendor shall deliver the Contract Items F.O.B. destination to the Agency's location.

6.4 Return of Unacceptable Items: If the Agency deems the Contract Items to be unacceptable, the Contract Items shall be returned to Vendor at Vendor's expense and with no restocking charge. Vendor shall either make arrangements for the return within five (5) days of being notified that items are unacceptable, or permit the Agency to arrange for the return and reimburse Agency for delivery expenses. If the original packaging cannot be utilized for the return, Vendor will supply the Agency with appropriate return packaging upon request. All returns of unacceptable items shall be F.O.B. the Agency's location. The returned product shall either be replaced, or the Agency shall receive a full credit or refund for the purchase price, at the Agency's discretion.

6.5 Return Due to Agency Error: Items ordered in error by the Agency will be returned for credit within 30 days of receipt, F.O.B. Vendor's location. Vendor shall not charge a restocking fee if returned products are in a resalable condition. Items shall

REQUEST FOR QUOTATION
05220081- PRESTRESSED CONCRETE BEAMS

be deemed to be in a resalable condition if they are unused and in the original packaging. Any restocking fee for items not in a resalable condition shall be the lower of the Vendor's customary restocking fee or 5% of the total invoiced value of the returned items.

7 VENDOR DEFAULT:

7.1 The following shall be considered a vendor default under this Contract.

- 7.1.1 Failure to provide Contract Items in accordance with the requirements contained herein.
- 7.1.2 Failure to comply with other specifications and requirements contained herein.
- 7.1.3 Failure to comply with any laws, rules, and ordinances applicable to the Contract Services provided under this Contract.
- 7.1.4 Failure to remedy deficient performance upon request.

7.2 The following remedies shall be available to Agency upon default.

- 7.2.1 Immediate cancellation of the Contract.
- 7.2.2 Immediate cancellation of one or more release orders issued under this Contract.
- 7.2.3 Any other remedies available in law or equity.

Federal Project No.	State Project No.	County	Year	Sheet No.	Total Sheets
—	5312-3-5.10	GRANT	2022	1	10

FALLS BRIDGE S312-3-5.10

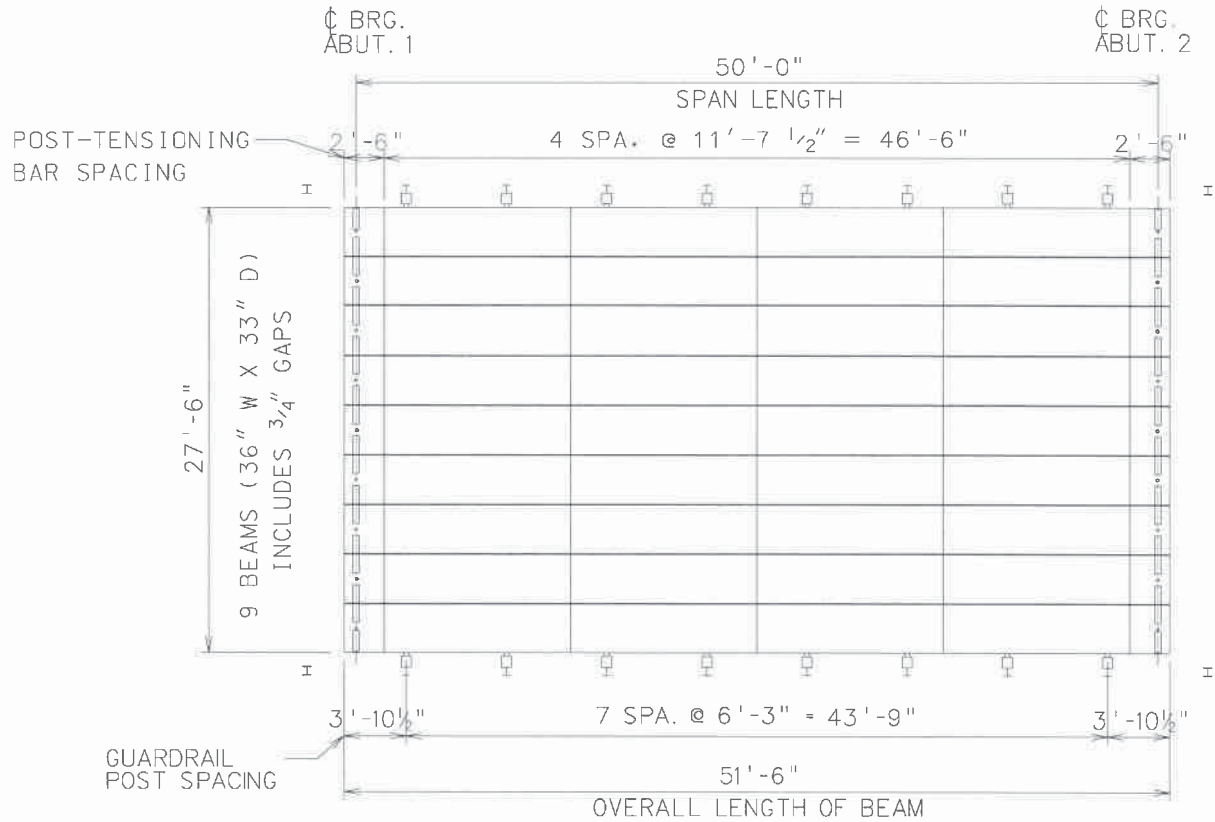

PLAN

SCALE : 0 7.5 ft.

REVISION NUMBER	SHEET NUMBER	REVISION	DATE	BY

THE WEST VIRGINIA DEPARTMENT OF TRANSPORTATION
DIVISION OF HIGHWAYS
FALLS BRIDGE
OVER
NORTH FORK PATTERSON CREEK
IN
GRANT COUNTY

DESIGNED KBR 08/21	DRAWN KBR 08/21	CHECKED	CHECKED
--------------------------	-----------------------	---------	---------

SHEET 1 OF 1
BRIDGE NO. 12-3-5.10

PROJECT NUMBERS		DISTRICT	COUNTY	SHEET NO.	TOTAL
STATE	FEDERAL	05	GRANT	2	10
S312-3-5.10	-----				

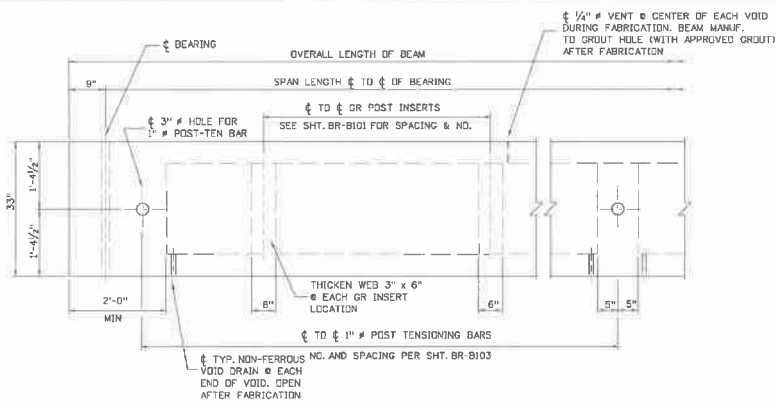

GENERAL ELEVATION VIEW

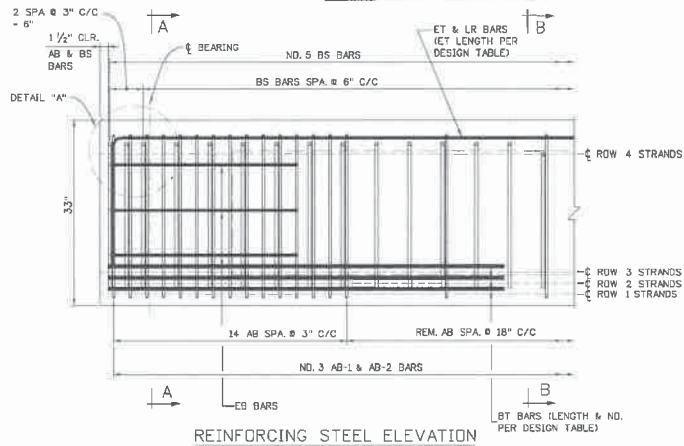

REINFORCING STEEL ELEVATION

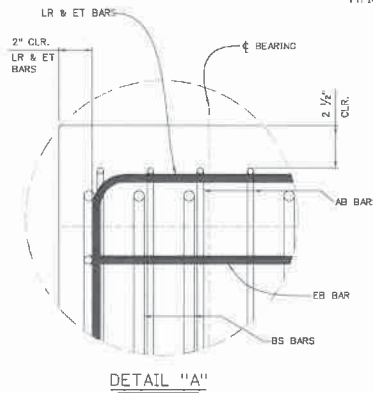

DETAIL "A"

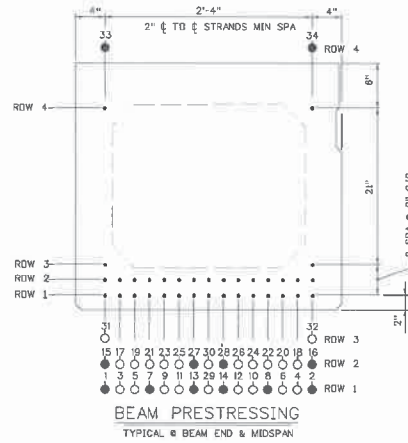

BEAM PRESTRESSING
TYPICAL @ BEAM END & MIDSPAN

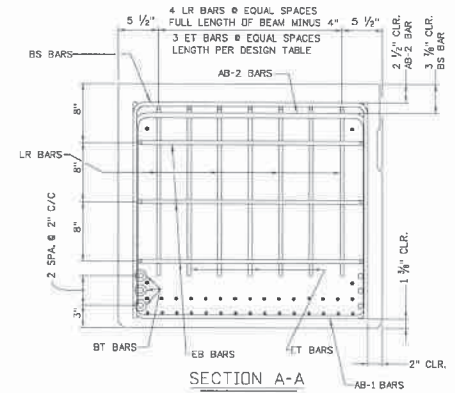

SECTION A-A

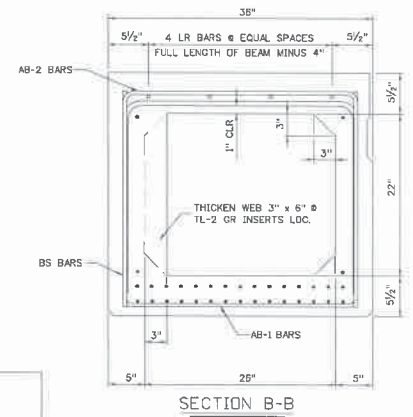

SECTION B-B

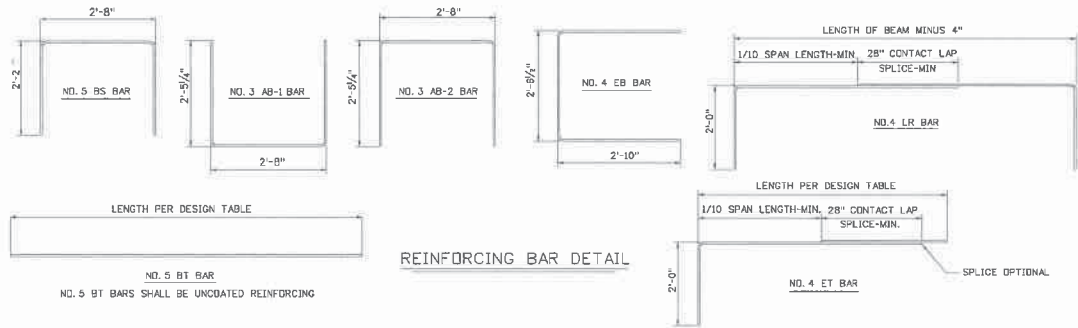

REINFORCING BAR DETAIL

- NOTES:**
- REFER TO SHEET BR-B102A FOR SHEAR KEY DETAILS.
 - DESIGNER SHALL USE THE FOLLOWING KEY TO INDICATE STRAND AND DEBONDING PATTERN ON "BEAM PRESTRESSING VIEW", THIS SHEET.
 - ACTIVE STRAND
 - ▽ DEBOND STRAND: LENGTH FROM END OF BEAM
 - △ DEBOND STRAND: LENGTH FROM END OF BEAM
 - DEBOND STRAND: LENGTH FROM END OF BEAM
 - THIS SHEET SHALL BE USED IN CONJUNCTION WITH STANDARD SHEETS BR-B338, BR-B100, BR-B101, BR-B102A & B, BR-B103, BR-B104, BR-B105A & B AND BR-B106 AS APPLICABLE.

WHEN A POST-TENSION ACCESS POCKET IS USED AS DETAILED ON SHEET BR-103 STRANDS IN ROWS 3 AND 4 SHALL BE ELIMINATED. THE BEAM SHALL BE REDESIGNED AS NECESSARY.

APPROVED: _____ DATE: 07-25-07

DIRECTOR, ENGINEERING DIVISION

WEST VIRGINIA DEPARTMENT OF TRANSPORTATION
DIVISION OF HIGHWAYS
ENGINEERING DIVISION

33" PRESTRESSED CONCRETE
BOX BEAMS
DESIGN AND ASSEMBLY DETAILS

STANDARD SHEET BR-B33A

PREPARED: 07-02-07

REVISION:

WEST VIRGINIA DEPARTMENT OF TRANSPORTATION
DIVISION OF HIGHWAYS
ENGINEERING DIVISION

FALLS BRIDGE
OVER
NORTH FORK OF PATTERSON CREEK
IN
GRANT COUNTY

33" PRESTRESSED BOX BEAM
DESIGN AND ASSEMBLY DETAILS

DESIGNED BY: TW/KBB
DRAWN BY: BH/KBB
CHECKED BY: TW/KDL
REVIEWED BY: THM/
DATE: 8/16/2021
SCALE:
SHEET OF
BRIDGE NO.
5312-3-5.10

STATE PROJECT NUMBER	FEDERAL PROJECT NUMBER	STATE DIST. NO.	COUNTY	SHEET NO.	TOTAL SHEETS
S312-3-5.10	-----	05	GRANT	3	10

MIN. CONCRETE STRENGTH @ RELEASE - 6000 PSI
 MIN. CONCRETE STRENGTH @ 28 DAYS - 8000 PSI
 INITIAL PULL/STRAND - 33,820 LBS
 CROSS-SECTION AREA/STRAND - 0.167 SQ. IN.

DESIGN DATA FOR 33" DEPTH ADJACENT BOX BEAM												
SPAN LENGTH ϕ TO ϕ BEARING	50'-0"	52'-0"	54'-0"	56'-0"	58'-0"	60'-0"	62'-0"	64'-0"	66'-0"	68'-0"	70'-0"	
OVERALL LENGTH OF BEAM	51'-8"	53'-6"	55'-6"	57'-6"	59'-6"	61'-6"	63'-6"	65'-6"	67'-6"	69'-6"	71'-6"	
NO. OF 270 KSI, 1/2" ϕ LDW-RELAXATION STRANDS, AREA/STRAND - 0.167 SQ. IN.	12	12	12	14	14	14	16	16	18	18	18	
STRAND POSITION NUMBER	RDW 1	1,2,7,8,13,14	1,2,7,8,13,14	1,2,7,8,13,14	1,2,7,8,13,14	1,2,7,8,13,14	1,2,5,6,9,10,13,14	1,2,5,6,9,10,13,14	1,2,5,6,9,10,13,14	1,2,5,6,9,10,13,14	1,2,5,6,9,10,13,14	
	RDW 2	15,16,27,28	15,16,27,28	15,16,27,28	15,16,21,22,27,28	15,16,21,22,27,28	15,16,21,22,27,28	15,16,21,22,27,28	15,16,19,20,23,24,27,28	15,15,19,20,23,24,27,28	15,16,19,20,23,24,27,28	
	RDW 3	-----	-----	-----	-----	-----	-----	-----	-----	-----	-----	
	RDW 4	33,34	33,34	33,34	33,34	33,34	33,34	33,34	33,34	33,34	33,34	33,34
PRESTRESSING FORCE IMMEDIATELY AFTER STRAND RELEASE, PpL (KIPS/BEAM)	394	394	394	457	458	458	521	521	583	584	585	
EFFECTIVE PRESTRESSING FORCE AFTER ALL LOSSES, Ppe (KIPS/BEAM)	359	360	361	414	416	417	468	470	521	522	524	
REQUIRED FACTORED MOMENT ϕ STRENGTH I, Mu (FT-KIPS/BEAM)	658	918	979	1042	1107	1173	1244	1312	1383	1454	1527	
FACTORED FLEXURAL RESISTANCE, Mr (FT-KIPS/BEAM)	1092	1092	1092	1280	1280	1280	1478	1478	1656	1656	1656	
TOTAL NO. DEBONDED STRANDS	-----	-----	-----	-----	-----	-----	-----	-----	-----	-----	-----	
DEBONDED STRAND POSITION NUMBER & SHIELDING LENGTH FROM EACH END	RDW 1	-----	-----	-----	-----	-----	-----	-----	-----	-----	-----	
	RDW 2	-----	-----	-----	-----	-----	-----	-----	-----	-----	-----	
NUMBER & LENGTH *4 ET TOP TENSION BARS ϕ EACH END	3 - *4 x 8'-6"	3 - *4 x 8'-6"	3 - *4 x 7'-0"	3 - *4 x 7'-0"	3 - *4 x 7'-0"	3 - *4 x 7'-6"	3 - *4 x 7'-6"	3 - *4 x 8'-0"	3 - *4 x 8'-0"	3 - *4 x 8'-0"	3 - *4 x 8'-6"	
NUMBER & LENGTH *6 BT BOTTOM TENSION BARS ϕ EACH END	6 - *6 x 7'-0"	6 - *6 x 6'-0"	6 - *6 x 7'-0"	6 - *6 x 8'-0"	6 - *6 x 8'-0"	6 - *6 x 8'-0"	6 - *6 x 8'-0"	6 - *6 x 8'-0"	4 - *6 x 9'-0"	4 - *6 x 9'-0"	4 - *6 x 9'-0"	
DESIGN CAMBER + = POSITIVE (UP) (INCHES)	ϕ RELEASE	0.19	0.18	0.17	0.21	0.26	0.25	0.39	0.38	0.51	0.50	0.48
	ϕ ERECTION	0.25	0.22	0.19	0.35	0.32	0.27	0.49	0.44	0.66	0.59	0.52
	ϕ FINAL	0.17	0.10	0.03	0.21	0.12	0.01	0.27	0.14	0.38	0.23	0.06
NUMBER & SPACING OF TL-2 GUARDRAIL INSERTS SEE NOTE 6	NO OF INSERTS REQD.											
	END OF BEAM TO ϕ OF FIRST INSERT EA. END ϕ OF 1st INSERT TO ϕ 2nd INSERT EA. END											
WEIGHT OF TYPICAL BEAM INCLUDING DIAPHRAGM (TONS)	19.9	20.6	21.3	22.0	22.7	23.4	24.4	25.1	25.8	26.5	27.2	

NOTES

- BEAM WEIGHTS LISTED IN THE DESIGN TABLE ARE BASED ON ZERO SKEW, 2 FT. LONG ENDBLOCK AND DIAPHRAGMS SPACED @ 15 FT C/C. WEIGHTS FOR SKEWED BEAMS, LONGER ENDBLOCKS AND ADDITIONAL DIAPHRAGMS SHOULD BE ADJUSTED ACCORDINGLY.
 FOR ADDITIONAL DIAPHRAGMS, ADD 497 LBS/DIAPHRAGM.
 FOR SKEW ADD 33 LBS/DEGREE OF SKEW/END.
 FOR LONGER ENDBLOCK, ADD 586 LBS/L'/END.
- DESIGNERS SHOULD NOTE THAT DATA IN STANDARD TABLE IS BASED ON EVEN SPAN LENGTHS, A TWO LANE STRUCTURE, 8 BEAMS WIDE AND ZERO SKEW. SUPERIMPOSED DEAD LOADS INCLUDE TYPE F PARAPET (321 PLF) AND A FWS OF 50 PSF. FOR NON-STANDARD BRIDGES DATA SHOULD BE VERIFIED AND IF REQUIRED NEW DESIGN DATA ENTERED INTO BLANK COLUMNS. IN NO CASE SHALL THE STANDARD DESIGN TABLE BE ALTERED.
- PREDICTED DESIGN CAMBER VALUES LISTED IN THE TABLE ARE BASED ON EMPIRICAL FORMULAS AND AS SUCH ARE APPROXIMATE. FOR MEMBERS WITH SPAN-TO-DEPTH RATIOS AT OR EXCEEDING 25, THE TOLERANCE VALUES LISTED IN APPENDIX B OF PCI MANUAL FOR QUALITY CONTROL, MNL-116, MAY NOT APPLY. MEASUREMENT OF CAMBER FOR COMPARISON TO PREDICTED DESIGN VALUES SHOULD BE COMPLETED WITHIN 72 HOURS OF RELEASE. ADDITIONALLY, CAMBER SHOULD BE EVALUATED UNDER CONDITIONS THAT MINIMIZE THE EFFECT OF TEMPERATURE VARIATION.

- DESIGNER, FABRICATOR, AND ERECTOR SHALL BE AWARE THAT SKEWED END BEAMS MAY TWIST OR WARP, CAUSING UNEVEN BEAM SEATING AT THE BEARINGS. THE CONTRACTOR IS REQUIRED TO CORRECT AT THE TIME OF ERECTION, BEFORE THE BEAMS ARE SECURED IN PLACE. METHOD OF CORRECTION SHALL PROVIDE AN EVEN, TOTAL BEARING AND A LEVEL TOP BEAM SURFACE. TOLERANCE, AFTER CORRECTION, SHALL BE (+/-) 1/8" INCH. THE FABRICATOR SHALL NOTIFY THE CONTRACTOR AND DESIGNER IF CORRECTIONS ARE REQUIRED PRIOR TO SHIPMENT.
- MAXIMUM BEAM SKEW SHALL BE 30 DEGREES.
- DESIGNER INPUT VALUES OF NUMBER OF INSERTS, DISTANCE FROM END OF BEAM TO ϕ FIRST INSERT, AND ϕ FIRST INSERT TO ϕ SECOND INSERT. ABOVE VALUES SHALL BE BASED ON THE REQUIRED 6'-3" GUARDRAIL POST SPACING ACROSS THE BRIDGE.
- THIS SHEET SHALL BE USED IN CONJUNCTION WITH STANDARD SHEETS BR-B33A, BR-B100, BR-B101, BR-B102A & B, BR-B103, BR-B104, BR-B105A & B AND BR-B106 AS APPLICABLE.

APPROVED: *Stephan Bailey* DIRECTOR, DESIGNER DIVISION DATE: 10-25-07

WEST VIRGINIA DEPARTMENT OF TRANSPORTATION
 DIVISION OF HIGHWAYS
 ENGINEERING DIVISION

DESIGN TABLE FOR 33"
 PRESTRESSED BOX BEAM
 STANDARD SHEET BR-B33B

PREPARED: 07-02-07

WEST VIRGINIA DEPARTMENT OF TRANSPORTATION
 DIVISION OF HIGHWAYS
 ENGINEERING DIVISION

FALLS BRIDGE
 OVER
 NORTH FORK PATTERSON CREEK
 IN
 GRANT COUNTY

DESIGN TABLE FOR 33"
 PRESTRESSED BOX BEAM

DESIGNED BY: TW/KBR
 DRAWN BY: TW/KBR
 CHECKED BY: TW/KBR
 REVIEWED BY: TW/KBR
 DATE: 06/18/2001
 SCALE:
 SHEET NO. OF
 BRIDGE NUMBER
 S312-3-510

PROJECT NUMBERS		DISTRICT	COUNTY	SHEET NO.	TOTAL
STATE	FEDERAL				
S312-3-5.10		05	GRANT	4	10

GOVERNING SPECIFICATIONS

THE WEST VIRGINIA DEPARTMENT OF TRANSPORTATION, DIVISION OF HIGHWAYS STANDARD SPECIFICATION FOR ROADS AND BRIDGES, ADOPTED 2017 AS AMENDED BY THE CURRENT SUPPLEMENTAL SPECIFICATIONS. THE CONTRACT PLANS AND CONTRACT SPECIAL PROVISIONS ARE THE GOVERNING PROVISIONS APPLICABLE TO THIS PROJECT.

ALL BEAMS ARE DESIGNED IN ACCORDANCE WITH THE AASHTO LRFD BRIDGE DESIGN SPECIFICATIONS, DATED 1998 AS AMENDED BY THE 2003 INTERIM SPECIFICATIONS.

DESIGN NOTES

ALL STANDARD ADJACENT PRESTRESSED CONCRETE BRIDGE BEAMS ARE DESIGNED TO MEET THE FOLLOWING CRITERIA:

1. DESIGN LOADS:

HL-93 LIVE LOAD IN ACCORDANCE WITH THE AASHTO LRFD BRIDGE DESIGN SPECIFICATIONS.

FUTURE WEARING SURFACE OF 50 PSF OF ROADWAY.

DIAPHRAGM DEAD LOAD, NUMBER REQUIRED BASED ON 15'-0" MAX. SPACING.

2. TWO LANE BRIDGE WITH AN OVERALL WIDTH OF 24'-5" (INCL. " GAP BETWEEN ADJ. BEAMS), A CURB-TO-CURB WIDTH OF 22'-1", TRANSVERSE POST-TENSIONING, AND ZERO SKEW.

3. DESIGN STRENGTH AND UNIT STRESSES:

MINIMUM CONCRETE STRENGTH @ STRAND RELEASE 6000 PSI
 MINIMUM CONCRETE STRENGTH @ 28 DAYS 8000 PSI

TEMPORARY STRESS LIMITS IN CONCRETE BEFORE LOSSES:

COMPRESSION STRESS LIMIT @ STRAND RELEASE 3600 PSI
 TENSION STRESS LIMIT @ STRAND RELEASE -200 PSI

COMPRESSIVE STRESS LIMITS IN CONCRETE @ SERVICE I AFTER LOSSES:

@ FINAL 1 (PS-DL+LL) 4800 PSI
 @ FINAL 2 (PS-DL) 3600 PSI
 @ FINAL 3 [50%(PS-DL)+LL] 3200 PSI

TENSILE STRESS LIMIT IN CONCRETE @ SERVICE III AFTER LOSSES:

@ FINAL 1 (PS-DL+LL) -270 PSI
 TENDON STRESS LIMIT PRIOR TO TRANSFER: 202.5 KSI
 TENDON STRESS LIMIT AFTER ALL LOSSES: 194.4 KSI

4. DEBONDING OR SHIELDING OF STRANDS TO REDUCE TEMPORARY TENSILE STRESSES IS PERMITTED, HOWEVER DEBONDING IS LIMITED TO 40% PER ROW AND 25% TOTAL. IN NO INSTANCES SHALL OUTER STRANDS BE DEBONDED. DEBONDED STRANDS SHALL BE SEPARATED BY AT LEAST ONE FULLY BONDED STRAND AND SHALL BE SYMMETRICAL ABOUT THE C OF THE BEAM. SHIELDING OF STRANDS SHALL BE ACCOMPLISHED BY TAPING OR TIGHTFITTING PLASTIC TUBES TAPED AT EACH END.

5. THE ELASTOMERIC BEARING PADS PROVIDED IN THE STANDARD DESIGNS ARE BASED ON ZERO GRADE AND ARE LIMITED TO A MAXIMUM OF 5% GRADE. IN INSTANCES OF GRADES EXCEEDING THIS LIMIT, PADS SHALL BE SPECIFICALLY DESIGNED. INDIVIDUAL PAD DESIGNS SHALL BE IN ACCORDANCE WITH SECTION 14, AASHTO LRFD. BEVELED SOLE PLATES ARE PERMITTED.

6. MAXIMUM BEAM SKEW SHALL BE 30 DEGREES.

7. WHEN ALTERNATE DESIGNS OR SITE SPECIFIC DESIGNS ARE PROVIDED, CRITERIA SET FORTH IN THESE STANDARDS SHALL APPLY.

8. NEGATIVE DESIGN CAMBER AFTER ALL LOSSES IS NOT PERMITTED.

9. EACH BEAM PROVIDED IN THESE STANDARD DESIGNS HAS BEEN LOAD RATED IN ACCORDANCE WITH SECTION 3.15 OF THE WEST VIRGINIA DIVISION OF HIGHWAYS BRIDGE DESIGN MANUAL. ADDITIONALLY, LOAD RATING PROCEDURES ARE IN ACCORDANCE WITH THE AASHTO MANUAL FOR CONDITION EVALUATION AND LOAD AND RESISTANCE FACTOR RATING OF HIGHWAY BRIDGES, 2003.

MATERIAL AND FABRICATION NOTES (CONT'D)

THE PRESTRESSED CONCRETE BEAMS SHALL CONFORM TO ALL APPLICABLE PROVISIONS OF SECTION 603 OF THE STANDARD SPECIFICATIONS.

MILD REINFORCEMENT:

ALL MILD REINFORCING STEEL SHALL BE GRADE 60, DEFORMED BILLET STEEL AND SHALL BE EPOXY COATED EXCEPT WHERE NOTED. ALL UNCOATED REINFORCING SHALL MEET THE REQUIREMENTS OF AASHTO M31. ALL EPOXY COATED REINFORCING SHALL MEET THE REQUIREMENTS OF AASHTO M284, EXCEPT WHERE AMENDED BY SECTION 709.1 OF THE STANDARD SPECIFICATIONS.

ALL TENSION LAP SPLICES SHALL BE A CLASS B, CONTACT TYPE. MINIMUM LAP SPlice LENGTHS SHALL BE AS GIVEN IN THE "LAP SPlice TABLE", THIS SHEET. ADDITIONALLY, IF LAP SPlicing OF ET, LR, AND BT BARS IS USED, TERMINATION OF THE SPlice SHALL BE NO CLOSER TO THE END OF THE BEAM THAN 1/10 OF THE SPAN LENGTH.

MINIMUM BAR BENDING DIAMETER SHALL BE 6 BAR DIAMETERS, EXCEPT THAT NO. 4 AB BARS MAY HAVE A MINIMUM BEND DIAMETER OF 4 BAR DIAMETERS.

MINIMUM CONCRETE COVER SHALL BE AS SPECIFIED IN SECTION 603.5 OF THE STANDARD SPECIFICATIONS, EXCEPT WHERE NOTED ON THE PLANS.

PRESTRESSING STRAND:

ALL PRESTRESSING STEEL SHALL BE 1/2" (SPECIAL) DIAMETER, GRADE 270, 7 WIRE UNCOATED, LOW-RELAXATION STRAND MEETING THE REQUIREMENTS OF AASHTO M203, SUPPLEMENT S1.

ALL BEAMS DESIGNED IN THESE STANDARDS UTILIZE STRANDS WITH A NOMINAL AREA OF 0.167 SQ. IN.

STRANDS WITH A NOMINAL AREA OF 0.153 SQ. IN. IS PERMITTED FOR INDIVIDUAL OR ALTERNATE DESIGNS,

HOWEVER THE DESIGNER IS ENCOURAGED TO USE THE LARGER STRAND FOR UNIFORMITY REASONS. IN NO CASES WILL STRESS-RELIEVED STRAND BE PERMITTED.

ALL STRANDS SHALL BE ENCLOSED INSIDE THE STIRRUP CAGE FOR THE FULL LENGTH OF THE BEAM.

ALL EXPOSED PRESTRESSING STRAND AT EACH BEAM END SHALL BE SHOP COATED WITH A LIQUID COLD-APPLIED BITUMINOUS ELASTOMERIC WATERPROOFING MEMBRANE. MATERIAL SHALL MEET ASTM C836-84.

CONCRETE:

ALL CONCRETE USED IN MANUFACTURING PRESTRESSED CONCRETE BEAMS SHALL MEET THE REQUIREMENTS OF SECTION 603.6 OF THE STANDARD SPECIFICATIONS.

DESIGN STRENGTHS SHALL MEET OR EXCEED THE MINIMUM VALUES SET FORTH IN THESE PLANS.

ELASTOMERIC BEARING PADS:

ALL BEARING PADS SHALL MEET THE APPLICABLE REQUIREMENTS AS SET FORTH IN SECTION 18.2 OF THE AASHTO LRFD BRIDGE CONSTRUCTION SPECIFICATIONS, 1998 EDITION WITH CURRENT INTERMS. ALL BEARINGS SHALL BE STEEL REINFORCED LAMINATED BEARINGS.

THE ELASTOMER MATERIAL SHALL BE 60 DUROMETERS WITH A MINIMUM LOW TEMPERATURE GRADE OF 3 (ZONE C).

ALL STEEL REINFORCING SHALL MEET THE REQUIREMENTS OF AASHTO M270, GRADE 36.

WELDING:

TACK WELDING OF REINFORCEMENT IS NOT PERMITTED. REINFORCING CAGES AND LONGITUDINAL STEEL SHALL BE ADEQUATELY TIED WITH APPROVED MEANS TO PREVENT RACKING AND MISALIGNMENT.

ALL WELDING OF FABRICATED ITEMS, AS SHOWN IN THESE PLANS SHALL BE IN ACCORDANCE WITH ALL APPLICABLE PROVISIONS OF AASHTO/AWS D1.5, 2002.

BAR SIZE	NO. 3	NO. 4	NO. 5	NO. 6
SPlice LENGTH	21"	28"	34"	41"

PRINT DATE 16-AUG-2022 15:52

Page 34 of 44

				DESIGNED	DATE	CHECKED	DATE	FALLS BRIDGE OVER NORTH FORK PATTERSON CREEK IN GRANT COUNTY	STANDARD BRIDGE PLANS ADJACENT BOX BEAM STANDARD BEAM NOTES 1 OF 2 SHEET NUMBER 3000GNI
WEST VIRGINIA DEPARTMENT OF TRANSPORTATION DIVISION OF HIGHWAYS				KGB	08/21	KDL	08/21		
NO.	REVISION	DATE	BY	DRAWN	DATE	REVIEWED	DATE		
				KGB	08/21				

16-AUG-2022 15:52

PROJECT NUMBERS		DISTRICT	COUNTY	SHEET NO.	TOTAL
STATE	FEDERAL				
5312-3-5.1B		05	GRANT	5	10

MATERIAL AND FABRICATION NOTES (CONT'D)

GUARDRAIL GUARDRAIL POSTS, TUBING & INSERTS:

ALL W-BEAM GUARDRAIL AND ATTACHMENT HARDWARE SHALL BE IN ACCORDANCE WITH SECTION 712.4 OF THE STANDARD SPECIFICATIONS. GUARDRAIL POSTS, STRUCTURAL TUBING, POST ATTACHMENT INSERTS, AND HARDWARE SHALL MEET THE LISTED MATERIAL AND COATING SPECIFICATIONS:

ITEM	DESCRIPTION	MATERIAL SPEC.	COATING SPEC.
POST	W6x25	AASHTO M270, GR 36	AASHTO M111
PLATE	1/2" x 7"	AASHTO M270, GR 36	AASHTO M111
TUBING	TS 8x4x3/16	ASTM A500, GR B	AASHTO M111
CHANNEL	C7x9.8	AASHTO M270, GR 36	AASHTO M111
FERRULE] TYPE 2A] ANCHOR	1/4" ϕ x 2 1/2" MIN LEN.	ASTM A108 (M117 STEEL)
WIRE		3/8" ϕ	ASTM A510 (1018 STEEL)
STUDS	1/4" ϕ x 8" LONG	ASTM A108 (1045 C.D. STEEL)	AASHTO M232
NUTS	1/4" ϕ	ASTM A563 AASHTO-M291, CLASS C	AASHTO M232
COUPLERS] TYPE 1A] ANCHOR	1/4" ϕ x 5" LONG	ASTM A108 (12L14 STEEL)
BOLTS		1/4" ϕ x 12" LONG	ASTM AASHTO-M164 (TYPE 1, HHH) A325
BOLTS	3/8" ϕ x ALL LEN. F3125	AASHTO-M164 (TYPE 1, HHH) A325	AASHTO M232
NUTS	3/8" ϕ	ASTM A563 AASHTO-M291, CLASS C	AASHTO M232
WASHERS	ALL	ASTM F436 AASHTO-M293	AASHTO M232

POST-TENSIONING BARS:

POST - TENSIONING THREAD BARS SHALL BE ONE INCH DIAMETER, 150 KSI STEEL, AND SHALL CONFORM TO AASHTO M275, TYPE II. STEEL THREAD BARS SHALL BE DESIGNED TO ALLOW THE USE OF HEAVY HEX NUTS AND COUPLERS THAT THREAD ONTO THE END OF THE DEFORMATIONS. HEAVY HEX NUTS AND COUPLERS SHALL BE OF A DESIGN AND MATERIAL RECOMMENDED BY THE BAR MANUFACTURER TO DEVELOP THE FULL TENSILE STRENGTH OF THE BAR. PROPERLY DOCUMENTED CERTIFIED MILL TEST REPORTS SHALL BE PROVIDED FOR EACH HEAT OF STEEL THREAD BARS.

ALL POST-TENSIONING THREAD BARS, NUTS, BEARING PLATES, COUPLERS, AND ANCILLARY HARDWARE SHALL BE HOT-DIPPED GALVANIZED IN ACCORDANCE WITH AASHTO M111. THE GALVANIZING PLANT SHALL ADMINISTER ADEQUATE QUALITY CONTROL MEASURES TO SAFEGUARD AGAINST HYDROGEN EMBRITTELEMENT. QUALITY CONTROL MEASURES SHALL COMPLY WITH ASTM A-143. CERTIFICATION FOR HOT-DIP GALVANIZING SHALL BE PROVIDED BY THE GALVANIZING PLANT.

ALL POST-TENSIONING BEARING PLATES SHALL CONFORM TO AASHTO M270, GRADE 36.

SHEAR KEY GROUT:

SHEAR KEY GROUT SHALL BE A GROUT THAT IS RECOMMENDED BY THE MANUFACTURER FOR A POURABLE GROUT APPLICATION AND THAT BASED ON THE MANUFACTURER'S TEST DATA WILL ATTAIN A MINIMUM OF 4500 PSI COMPRESSIVE STRENGTH IN 3 DAYS UNDER CONDITIONS REPRESENTATIVE OF THE CONDITIONS TO BE EXPERIENCED AT THE SITE. THE GROUT MUST BE LISTED ON THE APPROVED LIST OF GROUTS PUBLISHED BY THE WEST VIRGINIA DIVISION OF HIGHWAYS, MATERIALS CONTROL, SOIL AND TESTING DIVISION. THE CONTRACTOR SHALL PRE-TEST THE PROPOSED GROUT FOR COMPRESSIVE STRENGTH AT 3 AND 7 DAYS AND SUBMIT THE RESULTS TO THE BRIDGE PROJECT MANAGER FOR APPROVAL PRIOR TO INSTALLATION OF THE GROUT IN THE STRUCTURE. THE TESTS WILL BE BASED ON A POURABLE CONSISTENCY WITH THE SAME WATER/GROUT MIXTURE RATIO TO BE USED IN THE STRUCTURE.

THE CONTRACTOR SHALL BE REQUIRED TO SUBMIT FOR EACH PROJECT, THE GROUT PRE-TEST RESULTS OBTAINED IN THE NOTE ABOVE. THE CONTRACTOR SHALL BE REQUIRED TO PERFORM A NEW PRE-TEST AND SUBMISSION FOR APPROVAL UNDER ANY OF THE FOLLOWING CONDITIONS:
 -A PERIOD OF 18 MONTHS HAS ELAPSED SINCE LAST PRE-APPROVAL TESTING.
 -GROUT MANUFACTURER HAS REVISED OR CHANGED THE GROUT SPECIFICATIONS.
 -THE CONTRACTOR ALTERS THE WATER/GROUT MIXTURE RATIO.
 -THE CONTRACTOR CHANGES GROUT MANUFACTURER.
 -THE CONTRACTOR IS REQUIRED TO COMPLETE THE GROUT STRENGTH TABLE ON BR-B103.

TEST PROCEDURE FOR DETERMINING THE COMPRESSIVE STRENGTH OF GROUT SHALL USE CUBE SPECIMENS IN ACCORDANCE WITH ASTM C109, AS MODIFIED BY ASTM C1107. GROUT TESTING IN ACCORDANCE WITH AASHTO T23 (STANDARD CYLINDER TEST) IS NOT ACCEPTABLE.

MATERIAL AND FABRICATION NOTES (CONT'D)

PROTECTIVE SURFACE TREATMENT:

EACH PRESTRESSED CONCRETE BEAM SHALL BE TREATED BY THE MANUFACTURER AT THE FABRICATION PLANT WITH AN APPROVED CONCRETE SEALER (SILANE). AN APPROVED LIST OF CONCRETE SEALERS ARE ON FILE AT THE WEST VIRGINIA DIVISION OF HIGHWAYS, MATERIALS, CONTROL, SOIL AND TESTING DIVISION. COVERAGE SHALL INCLUDE TOP AND BOTTOM OF INTERIOR BEAMS, AND TOP, BOTTOM AND EXTERIOR SIDE OF EXTERIOR BEAM. APPLICATION RATE SHALL BE PER TREATMENT MANUFACTURER'S RECOMMENDATION. AFTER COMPLETION OF THE SILANE TREATMENT BY FABRICATOR AND A MAXIMUM OF FIVE WORKING DAYS PRIOR TO SHIPMENT OF THE BEAMS, THE FABRICATOR SHALL BE RESPONSIBLE FOR ABRASIVE BLAST CLEANING TO CLEAN WHITE CONCRETE THE INTERIOR SIDES OF BEAMS FOR THE FULL LENGTH. CLEAN WHITE CONCRETE SHALL MEAN REMOVAL OF ALL DIRT, GREASE, OIL, AND LOOSE CONCRETE LAITANCE AND PROVIDE A ROUGHENED CONCRETE SURFACE. BLASTING MEDIUM SHALL BE APPROVED BY THE DIVISION OF HIGHWAYS.

SHOP DRAWINGS:

THE FABRICATOR SHALL BE RESPONSIBLE FOR THE PREPARATION OF SHOP DRAWINGS IN ACCORDANCE WITH THE WEST VIRGINIA DIVISION OF HIGHWAYS DOCUMENTS, DD-102 AND THE STANDARD SPECIFICATIONS.

PROCEDURE NOTES

- INSTALL ONE INCH THICK SPACER AND GROUT STOP BY GLUING TO ONE SIDE, FOR THE ENTIRE LENGTH OF EACH BEAM PRIOR TO SETTING BEAMS. GLUE SHALL BE AN APPROVED CONSTRUCTION TYPE GLUE OR EPOXY ADHESIVE. GROUT STOP MAY BE INSTALLED AFTER BEAMS ARE SET. GLUE A 3/4" x 2" x 2" PIECE OF PRESSURE TREATED PLYWOOD AT EACH THREAD-BAR LOCATION TO ENSURE THAT A 3/4" GAP IS OBTAINED. PLYWOOD SPACERS TO BE OFFSET APPROXIMATELY 2 FEET FROM THE THREAD-BAR HOLE AND CENTERED ON THE HOLE DEPTH. PLYWOOD SPACERS ARE REQUIRED ON ONLY ONE BEAM EDGE FACE OF ABUTTING BEAMS. AFTER THE BEAMS ARE SET AND THE THREAD-BARS INSTALLED, PULL THE ENTIRE SUPERSTRUCTURE TOGETHER BY APPLYING A POST-TENSIONING FORCE OF APPROXIMATELY 3000 POUNDS. AT THIS STAGE THE GAP BETWEEN BEAMS SHALL BE A UNIFORM 3/4" WITH ALL SWEEP REMOVED. RECORD THE ACTUAL FORCE APPLIED.
- FILL THE GAP BETWEEN BEAMS AND SHEAR KEY FULL DEPTH WITH THE PRE-APPROVED, PRE-TESTED GROUT MIXTURE. FROM EACH BATCH, PREPARE JOB CONTROL GROUT CUBES FOR THREE AND SEVEN DAY TESTS. THESE JOB CONTROL SAMPLES WILL BE USED TO DETERMINE WHEN THE GROUT HAS ATTAINED A MINIMUM COMPRESSIVE STRENGTH OF 4500 PSI. A MINIMUM OF THREE SPECIMENS PER TEST SHALL BE OBTAINED, AND THE AVERAGE OF THE TEST RESULTS USED. ACCEPTANCE SAMPLING AND TESTING OF THE GROUT IS THE RESPONSIBILITY OF THE CONTRACTOR; HOWEVER, A REPRESENTATIVE OF THE WVDOT SHALL WITNESS ALL OF THE ACCEPTANCE SAMPLING AND TESTING.
- IN NO INSTANCE SHALL THE CONTRACTOR PROCEED WITH POST-TENSIONING OR OTHER BEAM ERECTION PROCEDURES UNTIL THE REQUIRED MINIMUM GROUT STRENGTH IS ATTAINED AND VERIFIED BY THE ENGINEER. IN THE EVENT THAT THE MINIMUM GROUT STRENGTH IS NOT ATTAINED, THE ENGINEER SHALL BE NOTIFIED AND CORRECTIVE ACTION TAKEN AT THE DIRECTION OF THE ENGINEER. SEE SHEAR KEY GROUT NOTE.
- AFTER THE GROUT HAS REACHED AN INITIAL SET CONDITION AND PRIOR TO ANY FINAL POST-TENSIONING PROCEDURES, THE CONTRACTOR SHALL REMOVE THE GROUT STOP AND INSPECT THE GROUT FOR VOIDS OR OTHER IRREGULARITIES. ANY VOIDS DEEPER THAN 2" FROM THE BOTTOM SHALL BE REGROUTED IN A MANNER ACCEPTABLE TO THE ENGINEER.
- AFTER GROUT AS BEEN PLACED AND REACHED MINIMUM COMPRESSIVE STRENGTH OF 4500 PSI AND HAS CURED A MINIMUM OF 3 DAYS, APPLY 50% OF THE FINAL POST-TENSIONING FORCE TO ALL THREAD-BARS, WORKING BEAM ENDS TO MIDSPAN. AFTER ALL THREAD-BARS HAVE BEEN TENSIONED TO 50%, APPLY THE REMAINING PERCENTAGE OF FINAL POST-TENSIONING FORCE, WORKING IN THE SAME SEQUENCE AS THE FIRST STAGE OF FINAL TENSIONING.
- MEASURE AND RECORD IN THE ELONGATION TABLE, THE ACTUAL TOTAL ELONGATION OF EACH THREAD-BAR. COMPARE THE MEASURED ELONGATION TO THE CALCULATED ELONGATION. A SIGNIFICANT DIFFERENCE BETWEEN MEASURED AND CALCULATED ELONGATIONS COULD INDICATE IMPROPER JACKING TECHNIQUES, FAULTY MATERIALS, FAULTY JACKS, OR IMPROPERLY CALIBRATED JACKS. IF THE DIFFERENCE IS GREATER THAN 15%, THEN THE JACK SHALL BE RE-CALIBRATED AND THE JACKING TECHNIQUES EVALUATED. IF, AFTER THE ABOVE STEPS ARE TAKEN, THE PERCENTAGE DIFFERENCE IS GREATER THAN 10%, THEN THE ENGINEER SHALL BE NOTIFIED AND CORRECTIVE ACTION TAKEN AT THE DIRECTION OF THE ENGINEER. ALL COSTS INVOLVED IN CORRECTION SHALL BE AT THE CONTRACTORS EXPENSE.
- USING SAW, TRIM EXCESS THREAD-BAR LEAVING 4" TO 6" PAST THE NUT. DO NOT TRIM THREAD-BARS BY TORCH CUTTING. TOUCH-UP TRIMMED ENDS WITH GALVICON OR EQUAL.
- INSTALL ANCHOR DOWELS

WEST VIRGINIA DEPARTMENT OF TRANSPORTATION
 DIVISION OF HIGHWAYS
 DISTRICT 5 BRIDGE DEPARTMENT

DESIGNED	DATE	CHECKED	DATE
KBB	08/21	KDL	08/21
DRAWN	DATE	REVIEWED	DATE
KBB	08/21		

FALLS BRIDGE
 OVER
 NORTH FORK PATTERSON CREEK
 IN GRANT COUNTY

STANDARD BRIDGE PLANS
 ADJACENT BOX BEAM STANDARD BEAM NOTES
 2 OF 2
 SHEET NUMBER 3000GN2

NO.	REVISION	DATE	BY

Public Road Dist.	State Dist.	State Project No.	Federal Project No.	Fiscal Year	County	Sheet No.	Total Sheets
W. V.	05	S512 3		2022	GRANT	6	10

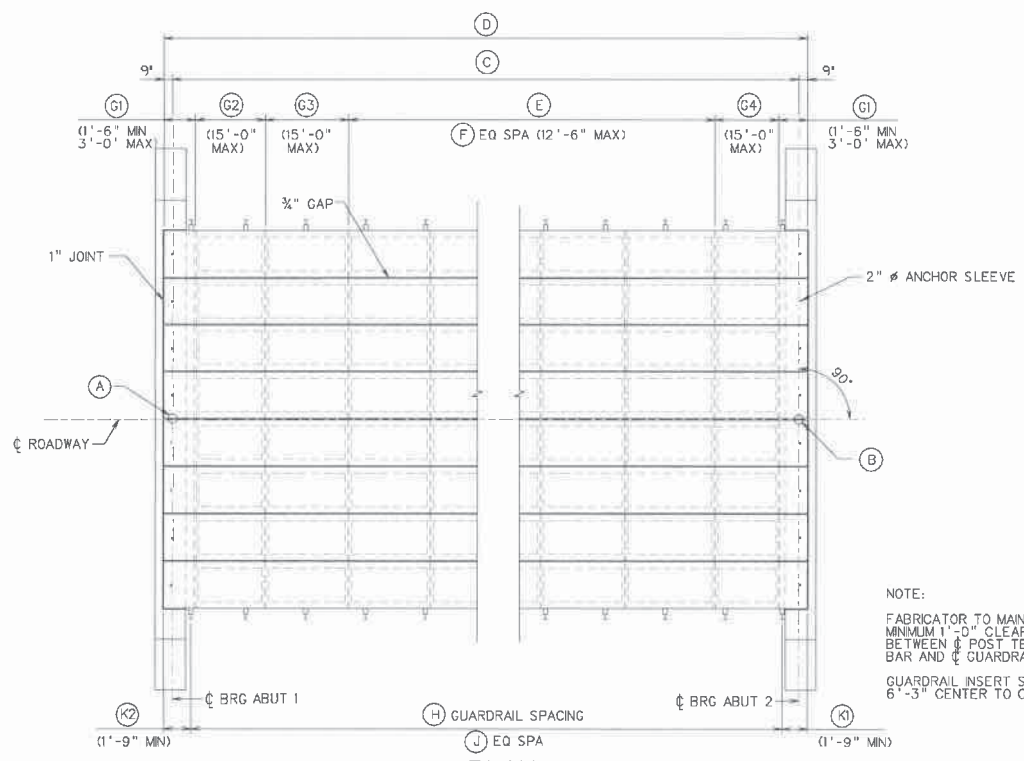

CONCRETE ADJACENT BOX BEAM CONTROL POINTS

CODE	DESCRIPTION	DIMENSION
A	WP STA	15+85.00
B	WP STA	16+35.00
C	BEARING TO BEARING LENGTH	50'-0"
D	OVERALL BEAM LENGTH	51'-6"
E	LENGTH POST TENSION SLEEVE SPACING (11'-7 1/2")	46'-6"
F	NUMBER OF EQUAL SPACING P. T. SLEEVE (11'-7 1/2")	4
G1	LENGTH FROM END OF BEAM TO FIRST SLEEVE	2'-6"
G2	LENGTH BETWEEN FIRST SLEEVE AND SECOND	11'-7 1/2"
G3	LENGTH BETWEEN SECOND AND THIRD SLEEVE	11'-7 1/2"
G4	LENGTH FROM LAST SLEEVE TO END OF BEAM	2'-6"
H	OVERALL LENGTH OF GUARDRAIL AT 6'-3" SPACING	56'-3"
J	NUMBER OF EQUAL SPACING GUARDRAIL INSERTS	7
K1	DISTANCE FROM END OF BEAM TO FIRST INSERT	3'-10 1/2"
K2	DISTANCE FROM LAST INSERT TO END OF BEAM	3'-10 1/2"
L	OVERALL WIDTH (INCLUDES 3/4" GAP)	27'-6"
M	THICKNESS OF WEARING AT CENTERLINE	3"
N	THICKNESS OF WEARING AT EDGE OF DECK	1"
O	NUMBER OF BEAMS	9
P	BEAM SIZE (WIDTH x DEPTH)	36" x 33"

NOTE:
FABRICATOR TO MAINTAIN MINIMUM 1'-0" CLEARANCE BETWEEN Ø POST TENSION BAR AND Ø GUARDRAIL INSERT
GUARDRAIL INSERT SPACING 6'-3" CENTER TO CENTER

GROUT STRENGTH TABLE

	3 DAY (PSI)	7 DAY (PSI)
PRE-TEST STRENGTH		
JOB CONTROL STRENGTH		
GROUT TYPE & MANUFACTURER		

POST-TENSIONING BAR LENGTH

BAR	FORMULA	LENGTH
VEVEN	3'-3"	30'-6"
VODDI	3'-4'-6"	

ELONGATION (INCHES)

BAR	CODE	CALC.	MEASURED															
			NO. 1	NO. 2	NO. 3	NO. 4	NO. 5	NO. 6	NO. 7	NO. 8	NO.	NO.						
Z	⊗	1.11																
V	⊗																	

CALCULATED ⊗ = $WF1.1 / 24.8$ ODD NO. BEAMS CALCULATED ⊗ = $(WF1.) \cdot 3 / 99.2$
 CALCULATED ⊗ = $WF1.1 / 99.2$

FINAL POST-TENSIONING FORCE
TYPE Z BARS = 80 KIPS
TYPE V BARS = 40 KIPS

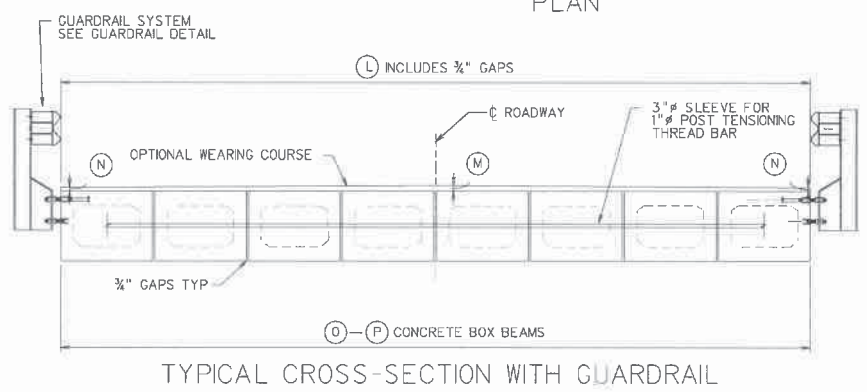

CHECK GUARDRAIL INSERT AND POST TENSION SLEEVE OVERLAP

LOCATION FROM END OF BEAM	1	2	3	4	5	6	7	8	9	10	11	12	13	14	15	16	17
GUARDRAIL INSERT LOCATION	3'-10 1/2"	10'-1 1/2"	16'-4 1/2"	22'-7 1/2"	28'-10 1/2"	35'-1 1/2"	40'-4 1/2"	47'-7 1/2"									
POST TENSIONING SLEEVE LOCATION	2'-6"	14'-1 1/2"	25'-9"	37'-4 1/2"	49'-0"												

NO SLEEVE ORDINATE SHOULD BE WITHIN 1'-0" OF GUARDRAIL INSERT
IT SHOULD BE VERIFIED BY THE DESIGNER THAT THERE IS NO CONFLICT BETWEEN THE GUARDRAIL INSERT, POST TENSIONING SLEEVE AND ANY SUBSTRUCTURE UNIT

PRINT DATE 17-AUG-2021 09:38
Page 36 of 44

DESIGNED KBB 08/21				CHECKED KDL 08/21				DATE 08/21				FALLS BRIDGE OVER NORTH FORK PATTERSON CREEK IN GRANT COUNTY				STANDARD BRIDGE PLANS CONCRETE ADJACENT BOX BEAM NO SKEW SHEET NUMBER 300QER1			
DRAWN KBB 08/21				DATE REVERSED				DATE				NOT TO SCALE							
NO.	REVISION	DATE	BY	WEST VIRGINIA DEPARTMENT OF TRANSPORTATION DIVISION OF HIGHWAYS DISTRICT 5 BRIDGE DEPARTMENT															

PROJECT NUMBERS		DISTRICT	COUNTY	SHEET NO.	TOTAL
STATE	FEDERAL				
5312-3-5-J0		05	GRANT	7	10

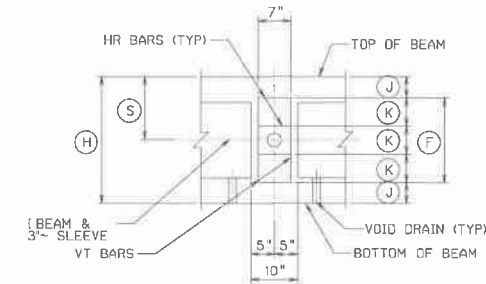
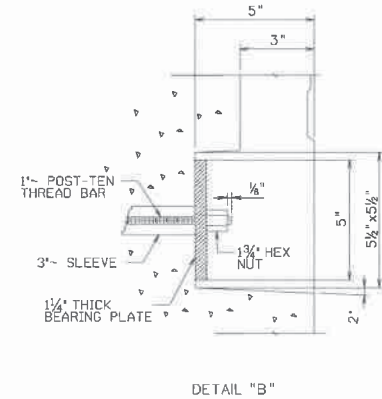
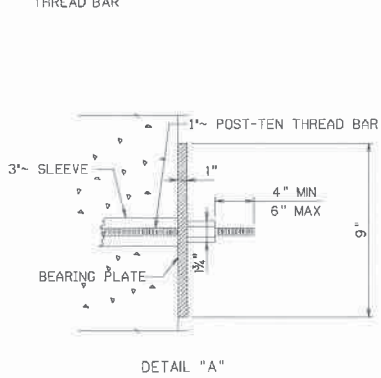
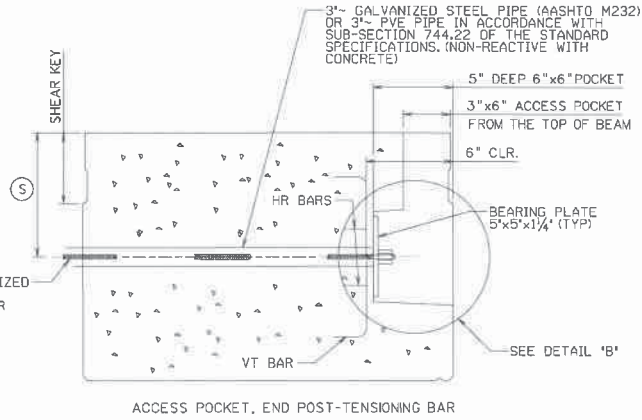
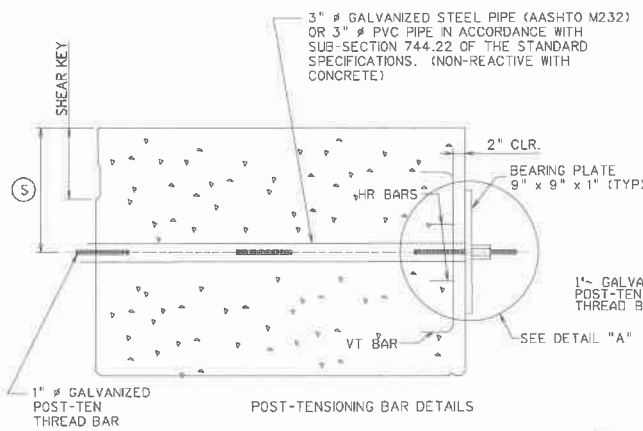

1/2" STRAND LIFTING LOOPS EMBEDDED FULL DEPTH OF BEAM MINUS COVER OF A MINIMUM OF 25 INCHES.
 NUMBER OF STRANDS PER SIDE SHALL BE DETERMINED BY THE FABRICATOR.
 2"- OF 3"- FOAM BLOCKOUT AFTER ERECTION CUT STRANDS FLUSH WITH BOTTOM OF VOID AND FILL WITH GROUT MEETING THE REQUIREMENTS OF SUB-SECT. 715.5

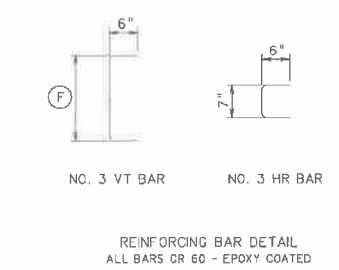
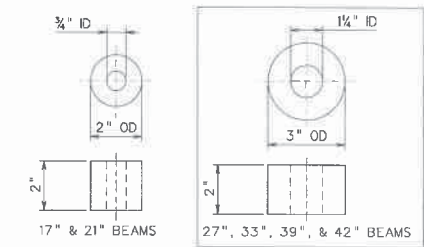
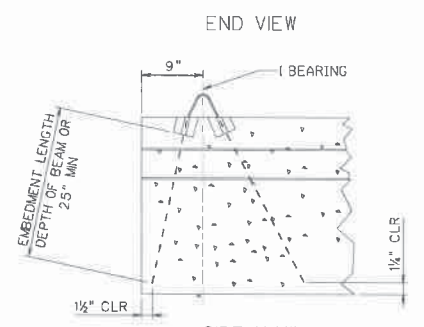
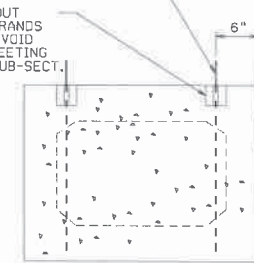

DIMENSIONS					
BEAM SIZE	REINFORCEMENT DIA	BAR SPACING	BAR DIST		
H	F	J	K	S	
IN.	IN.	IN.	IN.	IN.	IN.
17	12	2 1/2	4	8 1/2	
21	12	4 1/4	4	10 1/2	
27	18	4 1/4	6	13 1/2	
33	24	4 1/4	8	16 1/2	
39	30	4 1/4	10	19 1/2	
42	33	4 1/4	11	21	

NOTE:
 SPACE POST-TENSIONING THREAD BARS TO AVOID CONFLICT WITH GUARDRAIL INSERTS.

FINAL POST-TENSIONING FORCE
 TYPE Z BARS = 80 KIPS
 TYPE V BARS = 40 KIPS

SPECIAL WARNING NOTES
 1. DO NOT STAND IN LINE WITH THE POST-TENSIONING BAR DURING TENSIONING PROCEDURES.
 2. NUTS, COUPLERS AND EXTENSION RODS USED IN THE POST-TENSIONING WORK SHALL BE THE MATERIAL APPROVED BY THE MANUFACTURER OF THE HIGH STRENGTH POST-TENSIONING RODS. IN NO CASE SHALL THE CONTRACTOR USE NON-APPROVED MATERIAL OR MATERIAL FROM TWO DIFFERENT SOURCES.

PRINT DATE
 16-AUG-2021 16:22

Page 37 of 44

16-AUG-2021 16:32

WEST VIRGINIA DEPARTMENT OF TRANSPORTATION DIVISION OF HIGHWAYS DISTRICT 5 BRIDGE DEPARTMENT				DESIGNED KBB	DATE 08/21	CHECKED KDL	DATE 08/21	FALLS BRIDGE OVER NORTH FORK PATTERSON CREEK IN GRANT COUNTY		STANDARD BRIDGE PLANS CONCRETE ADJACENT BOX BEAM MISCELLANEOUS BEAM DETAIL 1 OF 3 SHEET NUMBER 3000MB1	
NO.	REVISION	DATE	BY	DRAWN KBB	DATE 08/21	REVIEWED	DATE	NOT TO SCALE			

PROJECT NUMBERS		DISTRICT	COUNTY	SHEET NO.	TOTAL
STATE	FEDERAL				
5312-3-5.10		05	GRANT	8	10

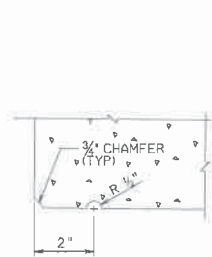

DRIP GROOVE DETAIL
EXTERIOR BEAMS

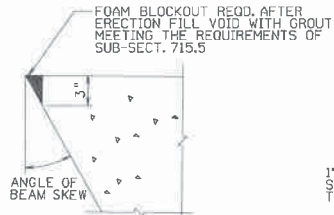

SKEW BLOCKOUT DETAIL

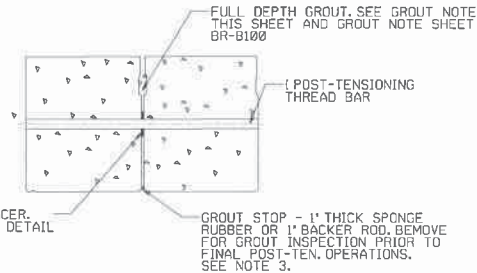

GROUT DETAILS

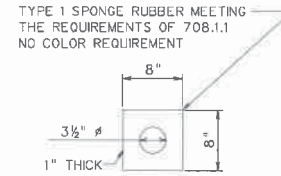

SPACER DETAIL

BEAM DEPTH	A
17"	1'-3 3/4"
21"	1'-4 3/4"
27"	1'-10 1/2"
33"	2'-4 3/4"
39"	2'-10 3/4"
42"	3'-1 3/4"

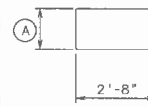

NO. 4 SS BAR

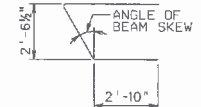

NO. 4 EB BAR

REINFORCING BAR DETAIL
SKEWED BEAMS

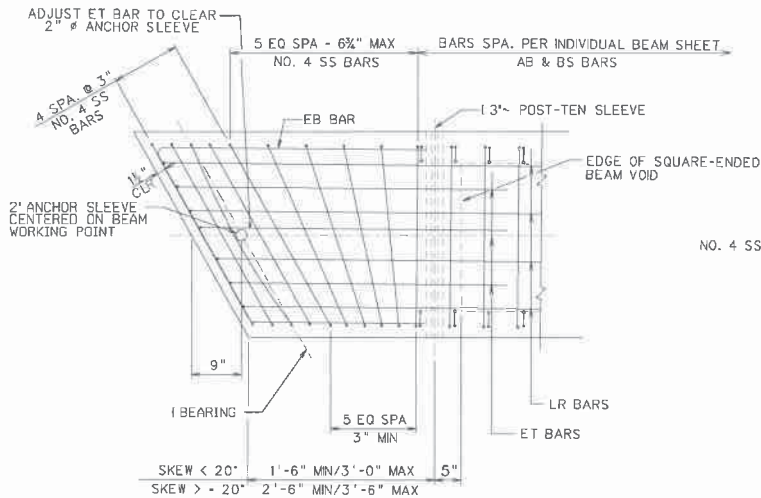

END BLOCK DETAIL - SKEWED BEAMS
WO/POST-TEN. ACCESS POCKET

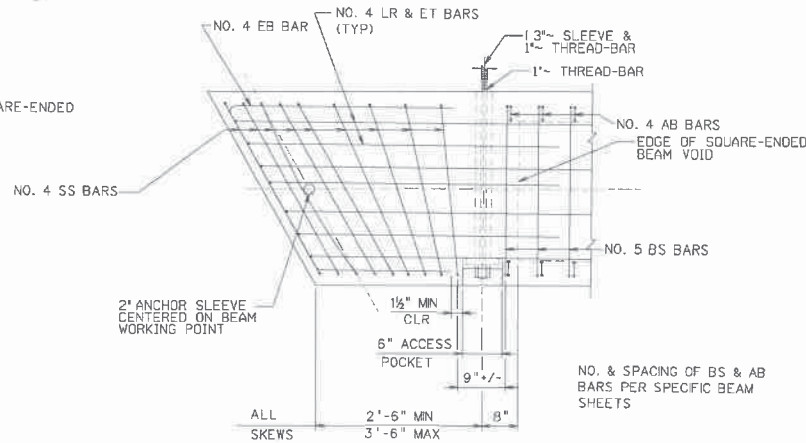

SHEAR REINFORCEMENT DETAIL
BEAMS WITH ACCESS POCKETS

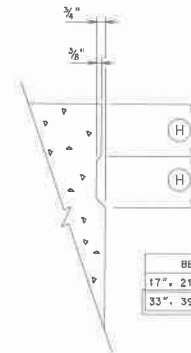

SHEAR KEY DETAIL

NO. & SPACING OF BS & AB
BARS PER SPECIFIC BEAM
SHEETS

BEAM DEPTH	H
17" - 21" & 27" BARS	4"
33" - 39" & 42" BARS	6"

PRINT DATE
16-AUG-2021 16:28

Page 38 of 44

NOT TO SCALE

WEST VIRGINIA DEPARTMENT OF TRANSPORTATION
DIVISION OF HIGHWAYS
DISTRICT 5 BRIDGE DEPARTMENT

DESIGNED	DATE	CHECKED	DATE
KBB	08/21	KDL	08/21
DRAWN	DATE	REVIEWED	DATE
KBB	08/21		

FALLS BRIDGE
OVER
NORTH FORK PATTERSON CREEK
IN GRANT COUNTY

STANDARD BRIDGE PLANS
CONCRETE ADJACENT BOX BEAM
MISCELLANEOUS BEAM DETAIL 2 OF 3
SHEET NUMBER 3000MB2

PROJECT NUMBERS		DISTRICT	COUNTY	SHEET NO.	TOTAL
STATE	FEDERAL				
S3/2-3-5-10		05	GRANT	9	10

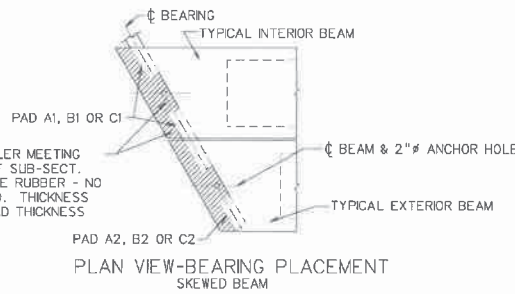
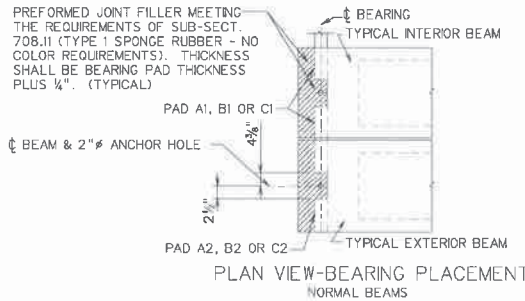
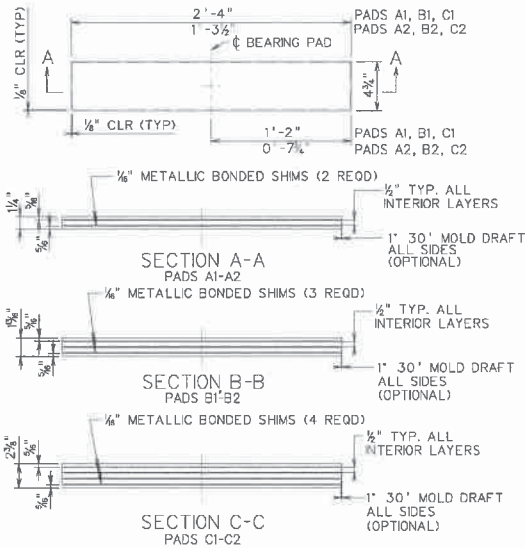

NOTES:

- ELASTOMERIC BEARING PADS ARE DESIGNED IN ACCORDANCE WITH DESIGN METHOD B CONTAINED IN SECTION 14 OF THE AASHTO LRFD BRIDGE DESIGN SPECIFICATIONS. FABRICATION SHALL BE IN ACCORDANCE WITH SECTION 18 OF THE AASHTO LRFD BRIDGE CONSTRUCTION SPECIFICATIONS.
- ALL BEARINGS ARE DESIGNED FOR A LOW TEMPERATURE ZONE C AND SHALL HAVE A DUREMETER HARDNESS OF 60. METALLIC REINFORCEMENT SHALL HAVE A MINIMUM YIELD STRENGTH OF 36 KSI.
- BEARING PADS ARE DESIGNED FOR ZERO BRIDGE GRADE. FOR BRIDGE GRADES GREATER THAN 5%, PADS SHALL BE SPECIFICALLY DESIGNED FOR THE GRADE. AS AN ALTERNATE, CAST-IN-PLACE BEVELED SOLE PLATES MAY BE USED.
- DESIGNER, FABRICATOR AND ERECTOR SHALL BE AWARE THAT SKEWED END BEAMS MAY TWIST OR WARP, CAUSING UNEVEN BEAM SEATING AT THE BEARINGS. THE CONTRACTOR IS REQUIRED TO CORRECT AT THE TIME OF ERECTION, BEFORE THE BEAMS ARE SECURED IN PLACE. METHOD OF CORRECTION SHALL PROVIDE AN EVEN, TOTAL BEARING AND A LEVEL TOP BEAM SURFACE. TOLERANCE AFTER CORRECTION SHALL BE 1/8 INCH. THE FABRICATOR SHALL NOTIFY THE CONTRACTOR AND DESIGNER IF CORRECTIONS ARE REQUIRED PRIOR TO SHIPMENT.
- FOR BEAMS WITH STEPPED ENDS USE PADS A2, B2, OR C2 ON BOTH SIDES OF EACH BEAM.
- ELASTOMERIC BEARING PADS SHALL BE INCLUDED IN THE PRICE OF THE BEAMS.

BOX BEAM BEARING PAD CONTROL DIMENSIONS								
PAD	LENGTH	WIDTH	HEIGHT	NO. SHMS	SHM SIZE	SPAN RANGES	MAXIMUM REACTION	MAXIMUM MOVEMENT ONE DIRECTION
A1	4 1/2"	28"	1 1/4"	2	1/2" x 4 1/2" x 2'-3 3/4"	20' - 38'	55 KIPS	0.39"
B1	4 1/2"	28"	1 3/4"	3	1/2" x 4 1/2" x 2'-3 3/4"	40' - 78'	75 KIPS	0.80"
C1	4 1/2"	28"	2 3/4"	4	1/2" x 4 1/2" x 2'-3 3/4"	80' - 100'	89 KIPS	1.02"
A2	4 1/2"	15 1/2"	1 1/4"	2	1/2" x 4 1/2" x 1'-3 3/4"	20' - 38'	28 KIPS	0.39"
B2	4 1/2"	15 1/2"	1 3/4"	3	1/2" x 4 1/2" x 1'-3 3/4"	40' - 78'	38 KIPS	0.80"
C2	4 1/2"	15 1/2"	2 3/4"	4	1/2" x 4 1/2" x 1'-3 3/4"	80' - 100'	45 KIPS	1.02"

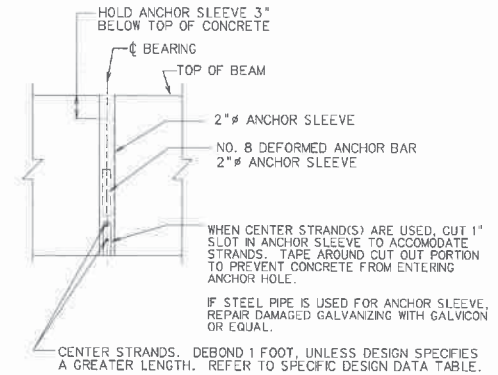
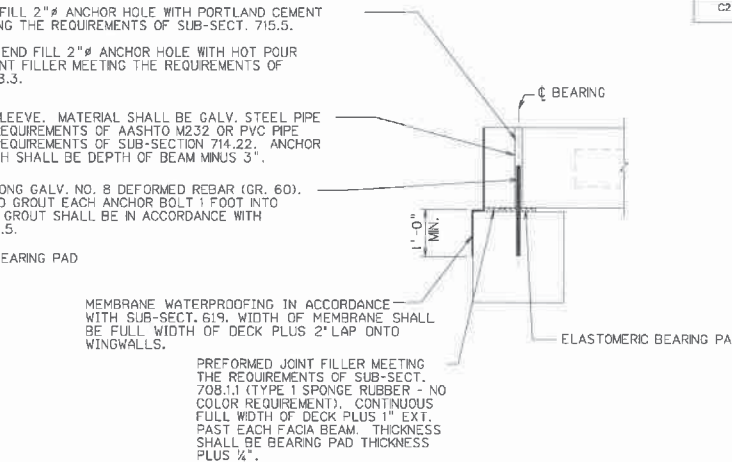
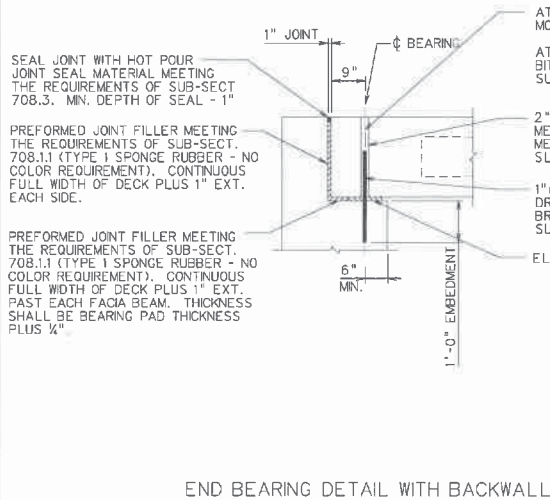

END BEARING DETAIL WITH BACKWALL

END BEARING DETAIL WITHOUT BACKWALL

ANCHOR SLEEVE DETAIL

NOT TO SCALE

WEST VIRGINIA DEPARTMENT OF TRANSPORTATION
DIVISION OF HIGHWAYS
DISTRICT 5 BRIDGE DEPARTMENT

DESIGNED	DATE	CHECKED	DATE
KBB	08/21	KDL	08/21
DRAWN	DATE	REVIEWED	DATE
KBB	08/21		

FALLS BRIDGE
OVER
NORTH FORK PATTERSON CREEK
IN GRANT COUNTY

STANDARD BRIDGE PLANS
CONCRETE ADJACENT BOX BEAM
MISCELLANEOUS BEAM DETAIL 3 OF 3
SHEET NUMBER 3000MB3

Pricing Page
05220081
EXHIBIT A

Item Number	Quantity	Unit of Measure	Description	Unit Price	Total
1	2	EACH	Exterior Beams 33" Depth x 36" Width by 51'-6" Overall Length (Ship with Guardrail & Hardware attached)	\$23,213.00	\$46,426.00
2	7	EACH	Interior Beams 33" Depth x 36" Width by 51'-6" Overall Length	\$23,213.00	\$162,491.00
3	18	EACH	Elastomeric Bearing Pads B1 (14) = 1-13/16" Height by 28" Width by 4 3/4" Length B2 (4) = 1-13/16" Height by 15 1/2" Width by 4 3/4" Length	Included	Included
4	18	EACH	Deformed Anchor Bolts 1" Diameter by 2' -0" Length	Included	Included
5	176	LF	Preformed Joint Filler 1" thick by 33" Width (56 LF) 1-1/2" thick by 6" Width (56 LF) 1-1/2" thick by 4-3/4" Width (14 LF)	Included	Included
6	5	EACH	Post Tensioning Bars 1" Diameter by 30'-6" Length with Hardware, Threaded	Included	Included
				GRAND TOTAL	\$208,917.00

VENDOR NAME	Technology International, Inc.
VENDOR ADDRESS	1349 South International Pkwy, Suite 2411, Lake Mary, Florida 32746
PHONE #	(407) 359-2373
EMAIL	tii@tii-usa.com
SIGNATURE	



Technology International, Inc.
 1349 South International Pkwy, Suite 2411
 Lake Mary, FL 32746
 Tel: (407) 359-2373
 Fax: (407) 359-2372
 E-mail: tii@tii-usa.com
 Website: www.tii-usa.com

Equipment Proposal

Description: Prestressed Concrete Beams for Falls Bridge

Solicitation #: CRFQ-0803-DOT2200000048

Agency: State of West Virginia

TII Ref: TII/WV/1021/19479

Date: 10/12/2021

In response to your quote request for Prestressed Concrete Beams for Falls Bridge, Technology International, Inc. is pleased to submit the following for consideration:

ITEM NO.	QTY	DESCRIPTION/ MODEL NO.	UNIT PRICE	EXTD. PRICE
1	2	Prestressed Concrete Box Beam Members 33" Deep x 3' wide x 61'-6", 90° Skew, estimated weight 52,000#)	\$23,213.00	\$46,426.00
2	7	Prestressed Concrete Box Beam Members 33" Deep x 3' wide x 61'-6", 90° Skew, estimated weight 52,000#)	\$23,213.00	\$162,491.00
3	18	Elastomeric Bearing Pads	Included	Included
4	18	Deformed Anchor Bolts	Included	Included
5	176	Performed Joint Filler	Included	Included
6	5	Post Tensioning Bars	Included	Included
Total.....			\$208,917.00	

Complete package consists of the following:

- Bearing pads, anchor bolts and rebounded sponge rubber at beam seat and backwalls.
- Post-tensioning system consisting of Dywidag bolts, plates, washers and sponge washers. 270ksi galvanized steel. Stressing tool provided upon request at additional rate. To be returned to EVCO after use by contractor.
- Structure mounted guardrail package: posts, tubing and rails, installed prior to shipment when applicable.
- Backer rod for keyway and hot pour joint sealer.
- Delivery to Job Site. Contractor Unloads and Sets.
- Shop drawings to be prepared and submitted to design engineer for approval. Independent WV PE stamp, if required, is by others.

A. Inclusions:

- Delivery to the project site on tractors/trailers of stretch and/or dolly configurations, unless otherwise noted.
- Beam delivery assumed to be two day delivery for each span.
- Site must be accessible to tractors/trailers of stretch and/or dolly configurations.

B. Exclusions:

- Unloading, setting or installing any components not quoted herein.
- Any Items not specifically called out or mentioned in the above proposal.
- Exterior or interior concrete coating, or mix additives not specifically identified in above proposal and description.

Warranty: Manufacturer's standard warranty applies.

Delivery:

- Estimated delivery is **28 Weeks** after receipt of order and approved submittal.
- Please note, due to COVID-19 there may be unanticipated disruptions and delays in the supply chains globally, for parts, components, equipment and internal manufacturing services such as engineering, production allocation, and logistics. This may result in manufacturing & delivery delays out of our control. We will do our best to communicate all such impacts and reduce the effects of any such delays.
- All delivery dates quoted are subject to manufacturer's confirmation at time of order.
- Submittal data will be provided for approval after receipt of order (if applicable)
- Customer to provide equipment and personnel to unload
- TII will provide MSO at time of payment confirmation. Customer is responsible for all titling and registration of trailer (If Applicable)

Freight: Included to Charleston, WV 25305.

Payment Terms: NET 30

Prompt Payment discount: 1/4 % 10 days

Quote Validity: 30 days.

***** Notes:**

- Quoted price is not available on a line item basis. This is an offer for a lump sum contract.

Technology International, Inc. Corporate data:

We are a small business and our Tax Payer Identification Number (TIN): 650342335. The price quoted does not include any sales, excise or similar taxes.

We trust that this proposal will meet your requirements and we look forward to hearing from you.

If you have any questions or need more information, please contact us by phone at 407-359-2373, fax at 407-359-2372 or email us at tii@tii-usa.com

Respectfully submitted,



Rifat Habib
Business Development Exec.
Technology International, Inc.