



Department of Administration  
 Purchasing Division  
 2019 Washington Street East  
 Post Office Box 50130  
 Charleston, WV 25305-0130

State of West Virginia  
 Centralized Request for Quote  
 Equipment

RECEIVED  
 08/18/21 08:54:33  
 WV Purchasing Division

<b>Proc Folder:</b> 896701		<b>Reason for Modification:</b>	
<b>Doc Description:</b> ADDENDUM NO_3 Double Drum Roller		Addendum No_3 To attach Vendor questions and responses	
<b>Proc Type:</b> Central Master Agreement			
<b>Date Issued</b>	<b>Solicitation Closes</b>	<b>Solicitation No</b>	<b>Version</b>
2021-08-09	2021-08-18 13:30	CRFQ 0803 DOT2200000014	4

**BID RECEIVING LOCATION**

BID CLERK  
 DEPARTMENT OF ADMINISTRATION  
 PURCHASING DIVISION  
 2019 WASHINGTON ST E  
 CHARLESTON WV 25305  
 US

**VENDOR**

**Vendor Customer Code:** 000000204452  
**Vendor Name :** West Virginia Tractor Company  
**Address :** P.O. Box 473  
**Street :** 214 Virginia Street West  
**City :** Charleston  
**State :** WV **Country :** USA **Zip :** 25322  
**Principal Contact :** Gary W. Grady  
**Vendor Contact Phone:** 304-346-5301 **Extension:**

**FOR INFORMATION CONTACT THE BUYER**  
 John W Estep  
 304-558-2566  
 john.w.estep@wv.gov

Vendor Signature X *Gary W. Grady* FEIN# 550621655 DATE 8-17-21

All offers subject to all terms and conditions contained in this solicitation

**ADDITIONAL INFORMATION**

ADDENDUM NO\_3

Addendum No\_3 issued to publish and distribute the attached information to the vendor community.

**REQUEST FOR QUOTATION:**

The West Virginia Purchasing Division is soliciting bids On behalf of the West Virginia Division of Highways, Department of Transportation to establish an open-end contract for a Double drum roller Caterpillar CB36B or equal. Per the Bid Requirements, Specifications, Terms and Conditions attached to this Solicitation.

**INVOICE TO****SHIP TO**

DIVISION OF HIGHWAYS  
EQUIPMENT DIVISION RT 33  
83 BRUSHY ROAD  
CROSSING, PO BOX 610  
BUCKHANNON WV  
US

DIVISION OF HIGHWAYS  
EQUIPMENT DIVISION  
83 BRUSHY FORK RD  
CROSSING  
BUCKHANNON WV  
US

Line	Comm Ln Desc	Qty	Unit Issue	Unit Price	Total Price
1	Double Drum Roller	10.00000	EA		

**Comm Code****Manufacturer****Specification****Model #**

22101505

**Extended Description:**

Class 591 Double Drum Roller

**SCHEDULE OF EVENTS**

<u>Line</u>	<u>Event</u>	<u>Event Date</u>
1	Pre-bid meeting - Buckhannon @10:00am	2021-07-28
2	Tech Questions due by 10:00am	2021-08-03

# SOLICITATION NUMBER: CRFQ DOT2200000014

## Addendum Number: 3

The purpose of this addendum is to modify the solicitation identified as CRFQ DOT2200000014 ("Solicitation") to reflect the change(s) identified and described below.

### Applicable Addendum Category:

- Modify bid opening date and time
- Modify specifications of product or service being sought
- Attachment of vendor questions and responses
- Attachment of pre-bid sign-in sheet
- Correction of error
- Other

### Additional Documentation:

Attach vendor questions and responses

Bid Opening moves to 08/18/21 at 1:30pm

### Terms and Conditions:

1. All provisions of the Solicitation and other addenda not modified herein shall remain in full force and effect.
2. Vendor should acknowledge receipt of all addenda issued for this Solicitation by completing an Addendum Acknowledgment, a copy of which is included herewith. Failure to acknowledge addenda may result in bid disqualification. The addendum acknowledgement should be submitted with the bid to expedite document processing.

**ADDENDUM ACKNOWLEDGEMENT FORM**  
**SOLICITATION NO.: CRFO DOT2200000014**

**Instructions:** Please acknowledge receipt of all addenda issued with this solicitation by completing this addendum acknowledgment form. Check the box next to each addendum received and sign below. Failure to acknowledge addenda may result in bid disqualification.

**Acknowledgment:** I hereby acknowledge receipt of the following addenda and have made the necessary revisions to my proposal, plans and/or specification, etc.

**Addendum Numbers Received:**

(Check the box next to each addendum received)

- |  |  |
|--|--|
| <input checked="" type="checkbox"/> Addendum No. 1 | <input type="checkbox"/> Addendum No. 6  |
| <input checked="" type="checkbox"/> Addendum No. 2 | <input type="checkbox"/> Addendum No. 7  |
| <input checked="" type="checkbox"/> Addendum No. 3 | <input type="checkbox"/> Addendum No. 8  |
| <input type="checkbox"/> Addendum No. 4            | <input type="checkbox"/> Addendum No. 9  |
| <input type="checkbox"/> Addendum No. 5            | <input type="checkbox"/> Addendum No. 10 |

I understand that failure to confirm the receipt of addenda may be cause for rejection of this bid. I further understand that that any verbal representation made or assumed to be made during any oral discussion held between Vendor's representatives and any state personnel is not binding. Only the information issued in writing and added to the specifications by an official addendum is binding.

West Virginia Tractor Company

\_\_\_\_\_  
Company

  
\_\_\_\_\_  
Authorized Signature

8-17-21

\_\_\_\_\_  
Date

**NOTE:** This addendum acknowledgement should be submitted with the bid to expedite document processing.

REQUEST FOR QUOTATION  
**591 Class Double Drum Roller Caterpillar CB36B or Equal.**

---

7.2 The following remedies shall be available to Agency upon default.

7.2.1 Immediate cancellation of the Contract.

7.2.2 Immediate cancellation of one or more release orders issued under this Contract.

7.2.3 Any other remedies available in law or equity.

**8. MISCELLANEOUS:**

**8.1 No Substitutions:** Vendor shall supply only Contract Items submitted in Response to the Solicitation unless a contract modification is approved in accordance with the provisions contained in this Contract.

**8.2 Reports:** Vendor shall provide quarterly reports and annual summaries to the Agency showing the Agency's items purchased, quantities of items purchased, and total dollar value of the items purchased. Vendor shall also provide reports, upon request, showing the items purchased during the term of this Contract, the quantity purchased for each of those items, and the total value of purchases for each of those items. Failure to supply such reports may be grounds for cancellation of this Contract.

**8.3 Contract Manager:** During its performance of this Contract, Vendor must designate and maintain a primary contract manager responsible for overseeing Vendor's responsibilities under this Contract. The Contract manager must be available during normal business hours to address any customer service or other issues related to this Contract. Vendor should list its Contract manager and his or her contact information below.

**Contract Manager:** Gary W. Grady  
**Telephone Number:** 304-346-5301  
**Fax Number:** 304-346-5305  
**Email Address:** wvtractor@msn.com

## West Virginia Ethics Commission



### Disclosure of Interested Parties to Contracts

Pursuant to *W. Va. Code* § 6D-1-2, a state agency may not enter into a contract, or a series of related contracts, that has/have an actual or estimated value of \$1 million or more until the business entity submits to the contracting state agency a Disclosure of Interested Parties to the applicable contract. In addition, the business entity awarded a contract is obligated to submit a supplemental Disclosure of Interested Parties reflecting any new or differing interested parties to the contract within 30 days following the completion or termination of the applicable contract.

For purposes of complying with these requirements, the following definitions apply:

*"Business entity"* means any entity recognized by law through which business is conducted, including a sole proprietorship, partnership or corporation, but does not include publicly traded companies listed on a national or international stock exchange.

*"Interested party" or "Interested parties"* means:

- (1) A business entity performing work or service pursuant to, or in furtherance of, the applicable contract, including specifically sub-contractors;
- (2) the person(s) who have an ownership interest equal to or greater than 25% in the business entity performing work or service pursuant to, or in furtherance of, the applicable contract. (This subdivision does not apply to a publicly traded company); and
- (3) the person or business entity, if any, that served as a compensated broker or intermediary to actively facilitate the applicable contract or negotiated the terms of the applicable contract with the state agency. (This subdivision does not apply to persons or business entities performing legal services related to the negotiation or drafting of the applicable contract.)

*"State agency"* means a board, commission, office, department or other agency in the executive, judicial or legislative branch of state government, including publicly funded institutions of higher education: Provided, that for purposes of *W. Va. Code* § 6D-1-2, the West Virginia Investment Management Board shall not be deemed a state agency nor subject to the requirements of that provision.

The contracting business entity must complete this form and submit it to the contracting state agency prior to contract award and to complete another form within 30 days of contract completion or termination.

*This form was created by the State of West Virginia Ethics Commission, 210 Brooks Street, Suite 300, Charleston, WV 25301-1804. Telephone: (304)558-0664; fax: (304)558-2169; e-mail: [ethics@wv.gov](mailto:ethics@wv.gov); website: [www.ethics.wv.gov](http://www.ethics.wv.gov).*

West Virginia Ethics Commission  
**Disclosure of Interested Parties to Contracts**

(Required by W. Va. Code § 6D-1-2)

Name of Contracting Business Entity: West Virginia Tractor Company Address: P.O. Box 473

Charleston, WV 25322

Name of Authorized Agent: Gary W. Grady Address: Charleston, WV

Contract Number: DOT22\*14 Contract Description: Double Drum Roller

Governmental agency awarding contract: DOT Division of highways

Check here if this is a Supplemental Disclosure

List the Names of Interested Parties to the contract which are known or reasonably anticipated by the contracting business entity for each category below (attach additional pages if necessary):

**1. Subcontractors or other entities performing work or service under the Contract**

Check here if none, otherwise list entity/individual names below.

**2. Any person or entity who owns 25% or more of contracting entity (not applicable to publicly traded entities)**

Check here if none, otherwise list entity/individual names below.

Gary and Christine Grady  
Steven Basham  
Susan Martin

**3. Any person or entity that facilitated, or negotiated the terms of, the applicable contract (excluding legal services related to the negotiation or drafting of the applicable contract)**

Check here if none, otherwise list entity/individual names below.

Signature: 

Date Signed: 8-17-2021

**Notary Verification**

State of West Virginia, County of Kanawha

I, Gary W. Grady, the authorized agent of the contracting business entity listed above, being duly sworn, acknowledge that the Disclosure herein is being made under oath and under the penalty of perjury.

Taken, sworn to and subscribed before me this 17th day of August, \_\_\_\_\_.

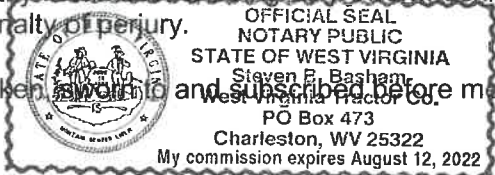

  
Notary Public's Signature

**To be completed by State Agency:**

Date Received by State Agency: \_\_\_\_\_

Date submitted to Ethics Commission: \_\_\_\_\_

Governmental agency submitting Disclosure: \_\_\_\_\_

STATE OF WEST VIRGINIA  
Purchasing Division

# PURCHASING AFFIDAVIT

**CONSTRUCTION CONTRACTS:** Under W. Va. Code § 5-22-1(i), the contracting public entity shall not award a construction contract to any bidder that is known to be in default on any monetary obligation owed to the state or a political subdivision of the state, including, but not limited to, obligations related to payroll taxes, property taxes, sales and use taxes, fire service fees, or other fines or fees.

**ALL CONTRACTS:** Under W. Va. Code §5A-3-10a, no contract or renewal of any contract may be awarded by the state or any of its political subdivisions to any vendor or prospective vendor when the vendor or prospective vendor or a related party to the vendor or prospective vendor is a debtor and: (1) the debt owed is an amount greater than one thousand dollars in the aggregate; or (2) the debtor is in employer default.

**EXCEPTION:** The prohibition listed above does not apply where a vendor has contested any tax administered pursuant to chapter eleven of the W. Va. Code, workers' compensation premium, permit fee or environmental fee or assessment and the matter has not become final or where the vendor has entered into a payment plan or agreement and the vendor is not in default of any of the provisions of such plan or agreement.

**DEFINITIONS:**

**"Debt"** means any assessment, premium, penalty, fine, tax or other amount of money owed to the state or any of its political subdivisions because of a judgment, fine, permit violation, license assessment, defaulted workers' compensation premium, penalty or other assessment presently delinquent or due and required to be paid to the state or any of its political subdivisions, including any interest or additional penalties accrued thereon.

**"Employer default"** means having an outstanding balance or liability to the old fund or to the uninsured employers' fund or being in policy default, as defined in W. Va. Code § 23-2c-2, failure to maintain mandatory workers' compensation coverage, or failure to fully meet its obligations as a workers' compensation self-insured employer. An employer is not in employer default if it has entered into a repayment agreement with the Insurance Commissioner and remains in compliance with the obligations under the repayment agreement.

**"Related party"** means a party, whether an individual, corporation, partnership, association, limited liability company or any other form or business association or other entity whatsoever, related to any vendor by blood, marriage, ownership or contract through which the party has a relationship of ownership or other interest with the vendor so that the party will actually or by effect receive or control a portion of the benefit, profit or other consideration from performance of a vendor contract with the party receiving an amount that meets or exceeds five percent of the total contract amount.

**AFFIRMATION:** By signing this form, the vendor's authorized signer affirms and acknowledges under penalty of law for false swearing (W. Va. Code §61-5-3) that: (1) for construction contracts, the vendor is not in default on any monetary obligation owed to the state or a political subdivision of the state, and (2) for all other contracts, that neither vendor nor any related party owe a debt as defined above and that neither vendor nor any related party are in employer default as defined above, unless the debt or employer default is permitted under the exception above.

**WITNESS THE FOLLOWING SIGNATURE:**

Vendor's Name: West Virginia Tractor Company

Authorized Signature: *Tracy Inady* Date: 8-017-2021

State of West Virginia

County of Kanawha, to-wit:

Taken, subscribed, and sworn to before me this 17 day of August, 2021.

My Commission expires August 12, 2022.

**AFFIX SEAL HERE**

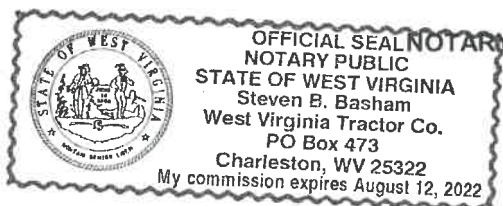

*Steven B. Basham*



**DESIGNATED CONTACT:** Vendor appoints the individual identified in this Section as the Contract Administrator and the initial point of contact for matters relating to this Contract.

Gary W. Grady PRES  
(Name, Title)  
Gary W. Grady, President .  
\_\_\_\_\_  
(Printed Name and Title)  
P.O. Box 473 Charleston, WV 25322  
\_\_\_\_\_  
(Address)  
304-346-5301 304-346-5305  
\_\_\_\_\_  
(Phone Number) / (Fax Number)  
wvtractor@msn.com  
\_\_\_\_\_  
(email address)

**CERTIFICATION AND SIGNATURE:** By signing below, or submitting documentation through wvOASIS, I certify that: I have reviewed this Solicitation in its entirety; that I understand the requirements, terms and conditions, and other information contained herein; that this bid, offer or proposal constitutes an offer to the State that cannot be unilaterally withdrawn; that the product or service proposed meets the mandatory requirements contained in the Solicitation for that product or service, unless otherwise stated herein; that the Vendor accepts the terms and conditions contained in the Solicitation, unless otherwise stated herein; that I am submitting this bid, offer or proposal for review and consideration; that I am authorized by the vendor to execute and submit this bid, offer, or proposal, or any documents related thereto on vendor's behalf; that I am authorized to bind the vendor in a contractual relationship; and that to the best of my knowledge, the vendor has properly registered with any State agency that may require registration.

By signing below, I further certify that I understand this Contract is subject to the provisions of West Virginia Code § 5A-3-62, which automatically voids certain contract clauses that violate State law.

West Virginia Tractor Company  
\_\_\_\_\_  
(Company)  
Gary W. Grady PRES  
\_\_\_\_\_  
(Authorized Signature) (Representative Name, Title)  
Gary W. Grady President  
\_\_\_\_\_  
(Printed Name and Title of Authorized Representative)  
8-17-21  
\_\_\_\_\_  
(Date)  
304-346-5301 304-346-5305  
\_\_\_\_\_  
(Phone Number) (Fax Number)

# State of West Virginia

## VENDOR PREFERENCE CERTIFICATE

Certification and application is hereby made for Preference in accordance with **West Virginia Code**, §5A-3-37. (Does not apply to construction contracts). **West Virginia Code**, §5A-3-37, provides an opportunity for qualifying vendors to request (at the time of bid) preference for their residency status. Such preference is an evaluation method only and will be applied only to the cost bid in accordance with the **West Virginia Code**. This certificate for application is to be used to request such preference. The Purchasing Division will make the determination of the Vendor Preference, if applicable.

**1. Application is made for 2.5% vendor preference for the reason checked:**

- Bidder is an individual resident vendor and has resided continuously in West Virginia, or bidder is a partnership, association or corporation resident vendor and has maintained its headquarters or principal place of business continuously in West Virginia, for four (4) years immediately preceding the date of this certification; **or**,
- Bidder is a resident vendor partnership, association, or corporation with at least eighty percent of ownership interest of bidder held by another entity that meets the applicable four year residency requirement; **or**,
- Bidder is a nonresident vendor which has an affiliate or subsidiary which employs a minimum of one hundred state residents and which has maintained its headquarters or principal place of business within West Virginia continuously for the four (4) years immediately preceding the date of this certification; **or**,

**2. Application is made for 2.5% vendor preference for the reason checked:**

- Bidder is a resident vendor who certifies that, during the life of the contract, on average at least 75% of the employees working on the project being bid are residents of West Virginia who have resided in the state continuously for the two years immediately preceding submission of this bid; **or**,

**3. Application is made for 2.5% vendor preference for the reason checked:**

- Bidder is a nonresident vendor that employs a minimum of one hundred state residents, or a nonresident vendor which has an affiliate or subsidiary which maintains its headquarters or principal place of business within West Virginia and employs a minimum of one hundred state residents, and for purposes of producing or distributing the commodities or completing the project which is the subject of the bidder's bid and continuously over the entire term of the project, on average at least seventy-five percent of the bidder's employees or the bidder's affiliate's or subsidiary's employees are residents of West Virginia who have resided in the state continuously for the two immediately preceding years and the vendor's bid; **or**,

**4. Application is made for 5% vendor preference for the reason checked:**

- Bidder meets either the requirement of both subdivisions (1) and (2) or subdivision (1) and (3) as stated above; **or**,

**5. Application is made for 3.5% vendor preference who is a veteran for the reason checked:**

- Bidder is an individual resident vendor who is a veteran of the United States armed forces, the reserves or the National Guard and has resided in West Virginia continuously for the four years immediately preceding the date on which the bid is submitted; **or**,

**6. Application is made for 3.5% vendor preference who is a veteran for the reason checked:**

- Bidder is a resident vendor who is a veteran of the United States armed forces, the reserves or the National Guard, if, for purposes of producing or distributing the commodities or completing the project which is the subject of the vendor's bid and continuously over the entire term of the project, on average at least seventy-five percent of the vendor's employees are residents of West Virginia who have resided in the state continuously for the two immediately preceding years.

**7. Application is made for preference as a non-resident small, women- and minority-owned business, in accordance with West Virginia Code §5A-3-59 and West Virginia Code of State Rules.**

- Bidder has been or expects to be approved prior to contract award by the Purchasing Division as a certified small, women- and minority-owned business.

**8. Application is made for reciprocal preference.**

- Bidder is a West Virginia resident and is requesting reciprocal preference to the extent that it applies.

Bidder understands if the Secretary of Revenue determines that a Bidder receiving preference has failed to continue to meet the requirements for such preference, the Secretary may order the Director of Purchasing to: (a) rescind the contract or purchase order; or (b) assess a penalty against such Bidder in an amount not to exceed 5% of the bid amount and that such penalty will be paid to the contracting agency or deducted from any unpaid balance on the contract or purchase order.

By submission of this certificate, Bidder agrees to disclose any reasonably requested information to the Purchasing Division and authorizes the Department of Revenue to disclose to the Director of Purchasing appropriate information verifying that Bidder has paid the required business taxes, provided that such information does not contain the amounts of taxes paid nor any other information deemed by the Tax Commissioner to be confidential.

**Bidder hereby certifies that this certificate is true and accurate in all respects; and that if a contract is issued to Bidder and if anything contained within this certificate changes during the term of the contract, Bidder will notify the Purchasing Division in writing immediately.**

Bidder: West Virginia Tractor Company

Signed: 

Date: 8-17-21

Title: President

\*Check any combination of preference consideration(s) indicated above, which you are entitled to receive.

**VENDOR:** West Virginia Tractor Co **Class 591**

Item No.	Description:	Model & Part Number Being Bid	Estimated Unit Quantity	Unit Price	Item Total Cost
1	Caterpillar CB36B or equal	BOMAG BW138 AD-5	10	\$57,990.00	\$579,900.00
<b>Total Bid Cost</b>					\$579,900.00

**Bid Will Be Awarded To The Lowest Overall Bid Total For All Items**

**Vendor Information**

<b>Company Name:</b>	West Virginia Tractor Company
<b>Contact Manager:</b>	Gary W. Grady
<b>Address:</b>	P.O. Box 473 Charleston, WV 25322
<b>Phone:</b>	304-346-5301
<b>Fax:</b>	304-346-5305
<b>E-mail:</b>	wvtractor@msn.com
<b>Signature:</b>	<i>Gary W. Grady</i>



# TECHNICAL DATA

TANDEM ROLLERS

BW 135 AD-5, BW 138 AD-5



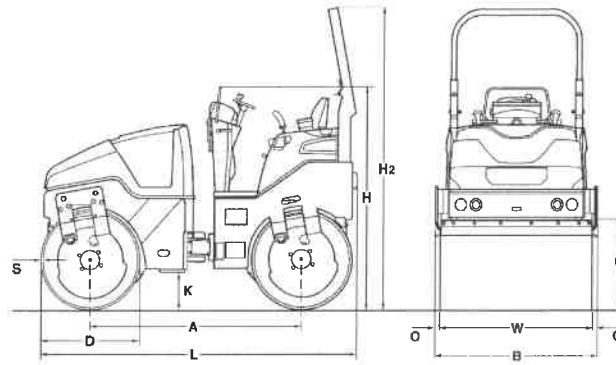

**Dimensions in mm**

	<b>A</b>	<b>B</b>	<b>C</b>	<b>D</b>	<b>H</b>	<b>H2</b>	<b>K</b>	<b>L</b>	<b>O</b>	<b>S</b>	<b>W</b>
<b>BW 135 AD-5</b>	1900	1390	700	900	1895	2703	340	2840	44	16	1300
<b>BW 138 AD-5</b>	1900	1468	700	900	1895	2703	340	2840	44	18	1380

**Shipping dimensions in m3**

**BW 135 AD-5**  
**BW 138 AD-5**

**without ROPS**

7,481  
7,900

**with ROPS**

10,670  
11,269

<b>Machine type</b>	<b>Compaction output (m3/h) at recommended soil layer thicknesses</b>		
	<b>Gravel, sand</b>	<b>Mixed soil</b>	<b>Silt, clay</b>
BW 135 AD-5	90-180	70-140	40-80
BW 138 AD-5	100-200	80-160	40-80

<b>Machine type</b>	<b>Compaction output (t/h) at different asphalt layer thicknesses</b>		
	<b>2-4 cm</b>	<b>6-8 cm</b>	<b>10-14 cm</b>
BW 135 AD-5	30-55	50-85	75-130
BW 138 AD-5	30-55	50-90	75-135

**Technical Data****BOMAG  
BW 135 AD-5****BOMAG  
BW 138 AD-5****Weights**

Operating weight w. ROPS CECE .....	kg	4.000	4.450
Average static linear load CECE .....	kg/cm	15,4	16,1
Grossweight .....	kg	5.500	5.500

**Dimensions**

Working width .....	mm	1.300	1.380
Track radius, inner .....	mm	2.665	2.616

**Driving Characteristics**

Speed .....	km/h	0- 10,0	0- 10,0
Working speed with vibration .....	km/h	0- 10,0	0- 10,0
Max. gradeability without/with vibr. ....	%	40/30	40/30

**Drive**

Engine manufacturer .....		Kubota	Kubota
Type .....		V 2203	V 2203
Emission stage .....		Stage IIIa / TIER4i	Stage IIIa / TIER4i
Cooling .....		water	water
Number of cylinders .....		4	4
Performance ISO 14396 .....	kW	33,3	33,3
Performance SAE J 1995 .....	hp	44,7	44,7
Speed .....	min-1		2.600
Speed adjustment 1 .....	min-1	2.140	2.770
Speed adjustment 2 .....	min-1	2.770	2.140
Electric equipment .....	V	12	12
Driven drum .....		front + rear	front + rear

**Brakes**

Service brake .....		hydrost.	hydrost.
Parking brake .....		hydromec.	hydromec.

**Steering**

Steering system .....		oscil.artic.	oscil.artic.
Steering method .....		hydrost.	hydrost.
Steering / oscillating angle +/- .....	grad	32/10	32/10
Crab walk .....	mm	0- 50	0- 50

**Exciter system**

Vibrating drum .....		front + rear	front + rear
Drive system .....		hydrost.	hydrost.
Frequency .....	Hz	50/56	50/56
Amplitude .....	mm	0,50	0,50
Centrifugal force .....	kN	39/48	45/57

**Sprinkler System**

Type of sprinkling .....		pressure	pressure
--------------------------	--	----------	----------

**Capacities**

Fuel .....	l	55,0	55,0
Water .....	l	310,0	310,0

Technical modifications reserved. Machines may be shown with options.

### Standard Equipment

- Hydrostatic travel and vibration drive
- 2 scrapers per drum, spring loaded and tiltable
- Pressure sprinkler system with interval switch
- Multi function travel lever
- Multi-function display incl. operating hour meter
- Water level
- Electronic fuel gauge
- Emergency STOP
- Individual control, vibration
- Intelligent Vibration Control (IVC)
- Integrated storage compartment
- Sliding seat incl. double travel lever
- Seat contact switch
- 12V socket
- Working lights front and rear
- Vandalism protection
- Lockable engine hood made of composite material
- Lashing eyes, galvanized
- Single point lifting device
- Back-up alarm

### Optional Equipment

- \*Foldable ROPS incl. seat belt
- Sun roof, rigid
- Sun roof, foldable with ROPS
- Weather protection for sun roof
- Weather protection cabin
- Seat heating
- ECONOMIZER with asphalt temperature display
- Temperature display
- BOMAG TELEMATIC
- Indicator and hazard lights
- Rotary beacon
- Optional lighting on ROPS
- Lighting for drum edge
- Battery disconnect switch
- Environmentally compliant hydraulic oil
- Theft protection
- Edge cutter-right/left
- Gravel scatterer
- Hydraulically adjustable crabwalk (50mm)
- Pointer
- Special painting
- Backup warning buzzer with broadband technology
- Flow divider
- 2. Amplitude:0,2mm
- ECOSTOP
- Outside mirrors
- Tablet holder set

\* Standard delivery with CE conformity  
(valid within European Union)



PRE 650 30 010

130220 Sa05

**BOMAG**  
Hellerwald  
D-56154 Boppard  
P.O. Box 5162  
Tel. (0)6742 - 1000  
Fax (0)6742 - 3090





# LEADERS IN COMPACTION.

ARTICULATED TANDEM ROLLERS, UP TO 5 T.





# MILLIONS OF KILOMETRES BEAR OUR SIGNATURE.

You build the finest roads so we can all move forward faster. And to ensure that you can progress faster, we build the best machines. As a member of the leading international FAYAT group, we supply machines for all areas of road construction – from soil compactors to cold planers and recyclers, from asphalt rollers to road pavers. For over 60 years, the history of our company has been synonymous with the history of road construction.

With our accumulated know-how, we are an innovation driver that sets the pace for an entire industry. BOMAG has developed a huge number of technologies, from systems for measuring and controlling compaction, such as ECONOMIZER and ASPHALT MANAGER, to technologies for reducing operating costs, such as ECOMODE and the most effective screed

heating in the market: MAGMALIFE. We offer solutions for a wide range of applications.

Our global network of experts and partners in over 120 countries is there to support you, from the configuration of the machines to providing solutions for the most challenging of tasks.

We owe our innovative strength to our more than 2,500 employees worldwide, their commitment and their unique wealth of experience. A source of know-how which has propelled us to worldwide market leadership in this sector. The reason for this is our unconditional commitment to quality: in product development and production, in the qualification of our employees, and in a service that guarantees optimal on-site support.

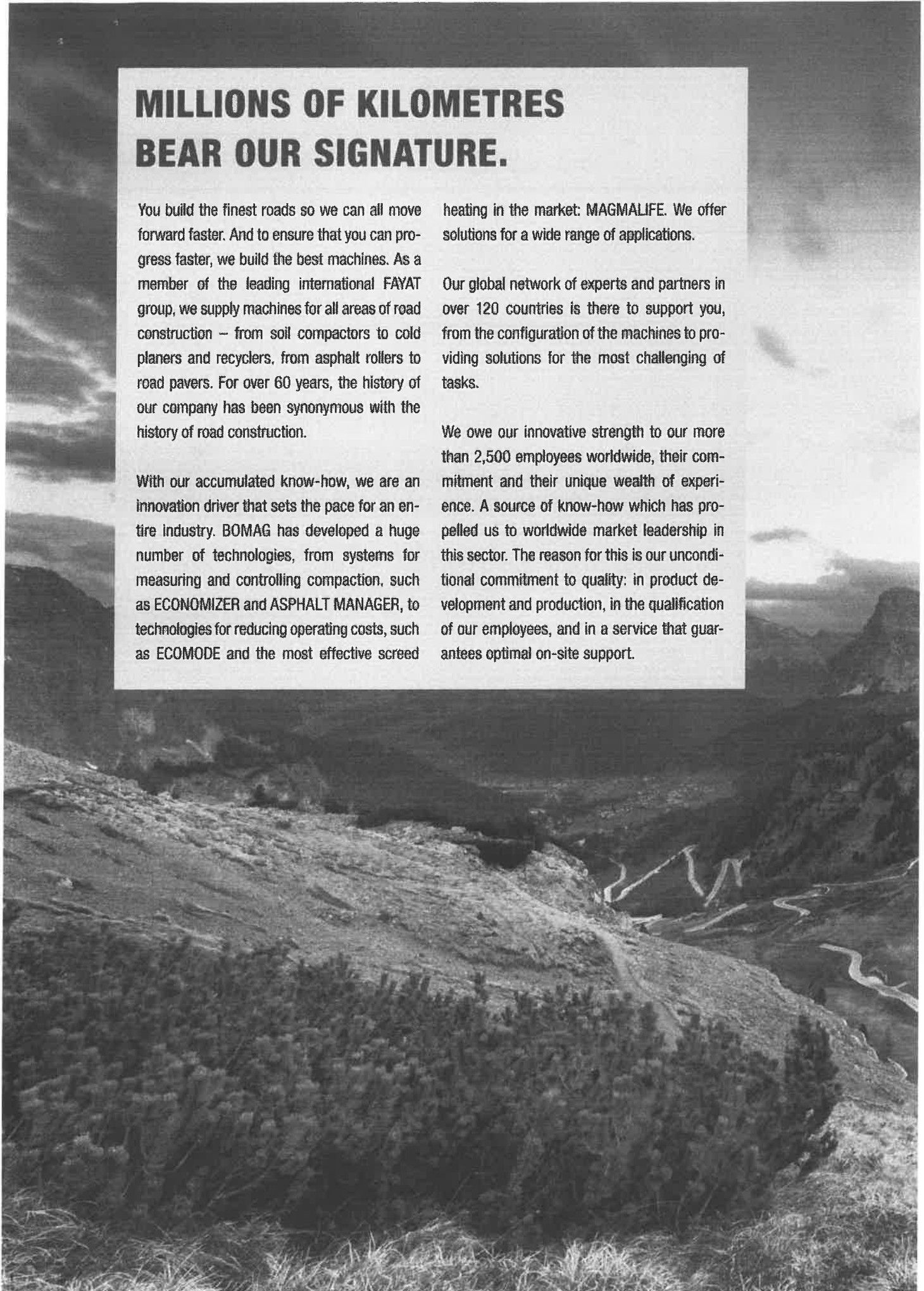

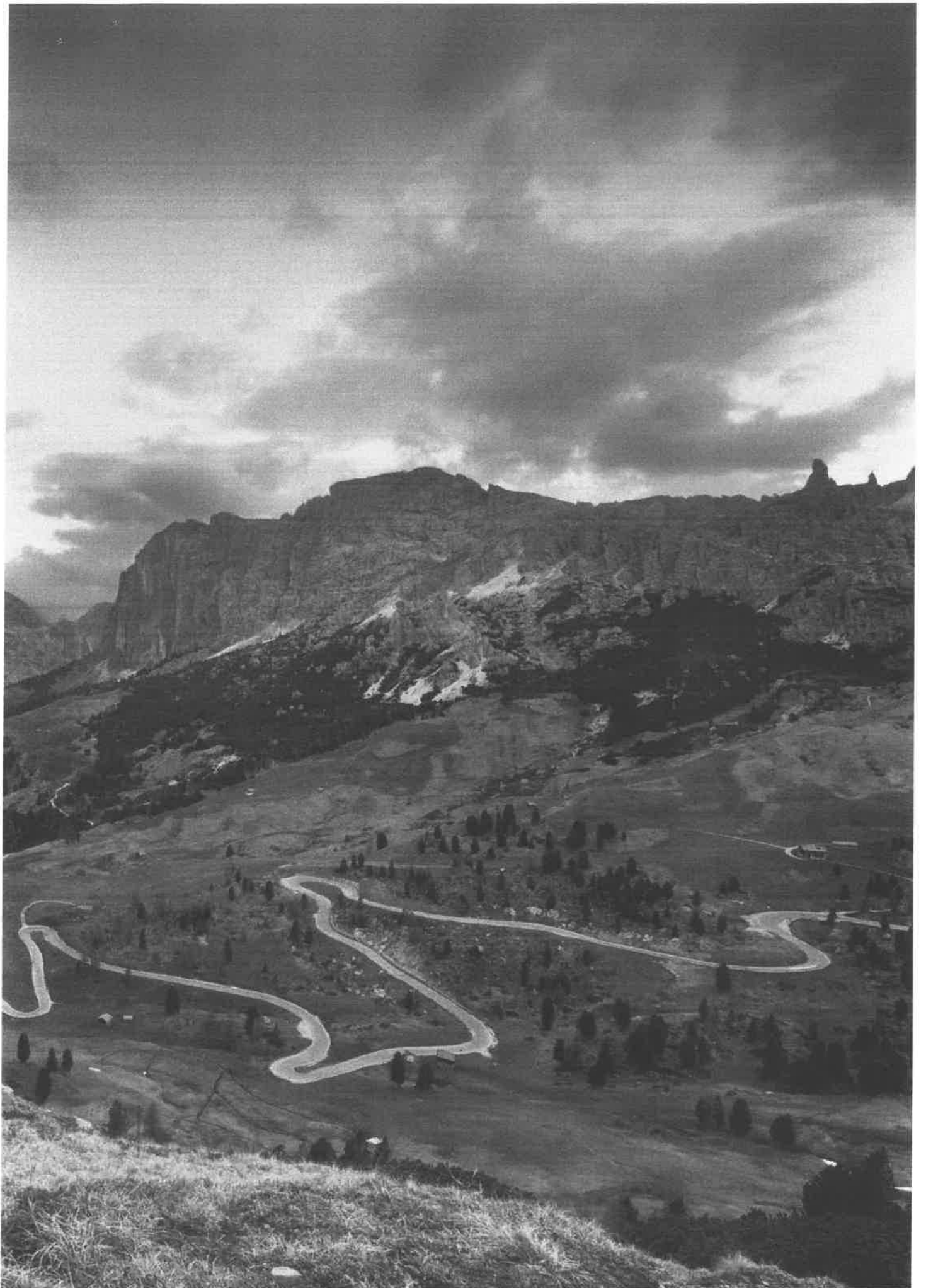

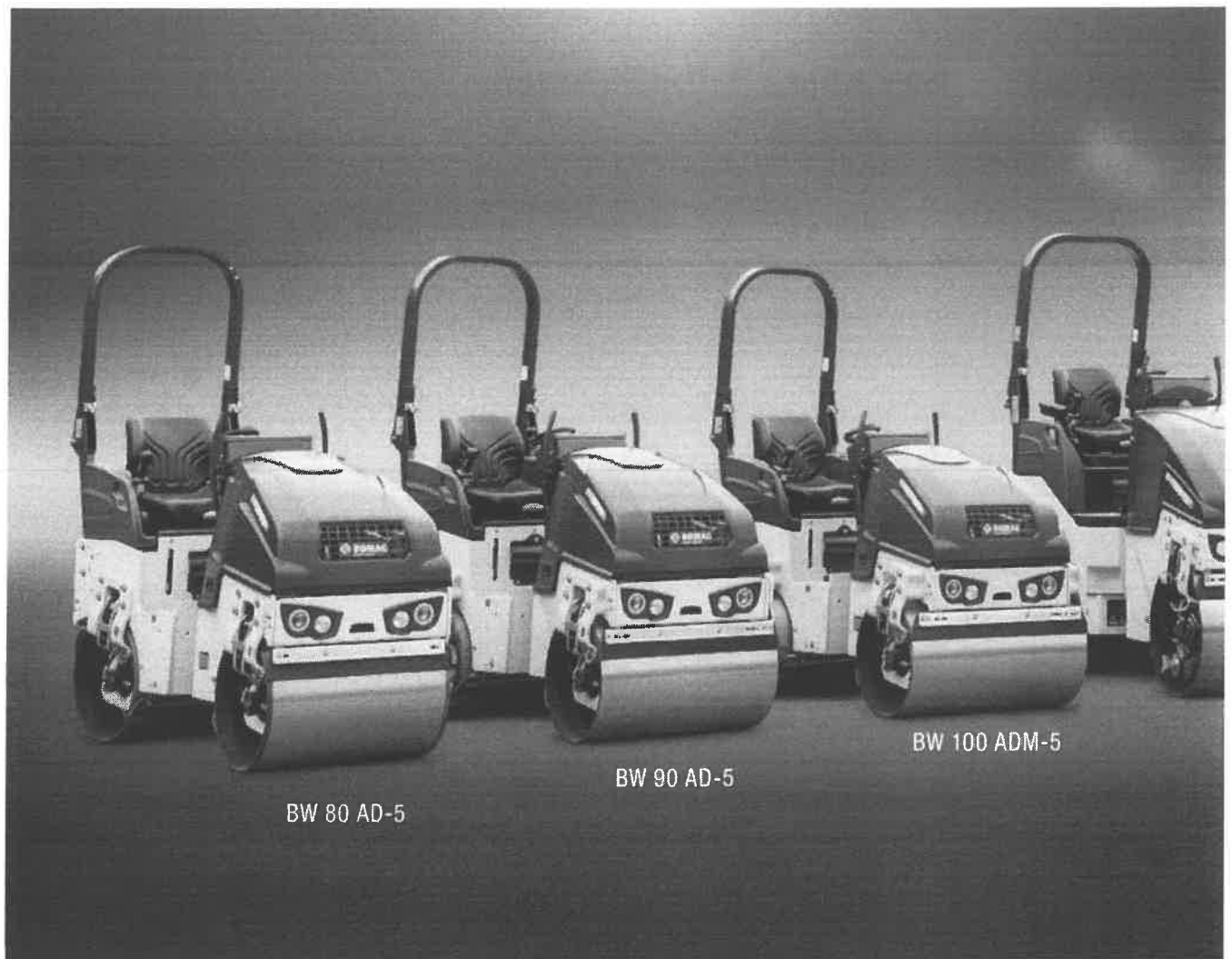

## THE WHOLE WORKS FOR EVERY PURPOSE.

### **ASPHALT COMPACTION IS A MATTER FOR BOMAG PROFESSIONALS.**

Just because you're using a compact machine doesn't mean you should miss out on productivity, operator comfort, performance and innovation. This is why our engineers do all they can to make each new generation even better, more economical and more productive. In doing so, they have only one goal in mind: Every BOMAG must

make our customers' work more efficient, more comfortable and more professional. Our close contact to you, our customers, helps us find solutions that result in real productivity gains, and make it possible for you to perform your wide-ranging tasks perfectly and productively. For light tandem rollers up to 5 tonnes operating weight, we also set the industry standard.

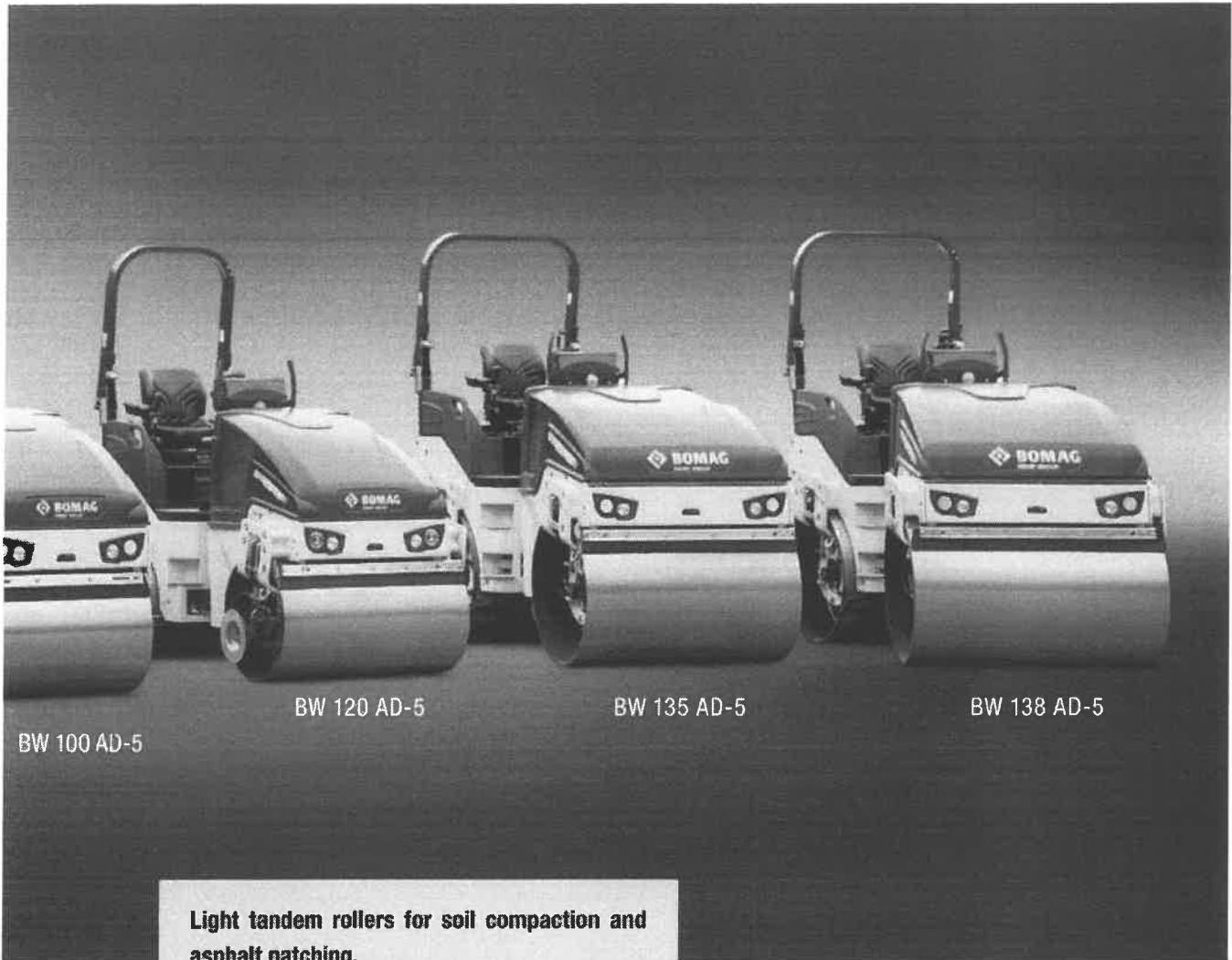

BW 100 AD-5

BW 120 AD-5

BW 135 AD-5

BW 138 AD-5

**Light tandem rollers for soil compaction and asphalt patching.**

Ideal for footpaths and repair work as well as finishing work in road construction. Compact BOMAG tandem rollers have also acquired an excellent reputation in landscaping.

In doing so, BOMAG focuses on closely matching your requirements. So trust our engineers' expertise and the service philosophy of our distribution network. Trust in proverbial BOMAG quality. Because we have only one goal at BOMAG: Making your work more productive.

## ALL ABOUT BOMAG.

### QUICK TO SERVICE

BOMAG has dispensed with lubrication nipples. The articulated joint is also maintenance free. The motor, central electrics and water pump are easily accessible. This saves time and simplifies daily maintenance.

### ROBUSTLY PRODUCED

The articulation joint is not welded to the frame and is easily accessible in case of emergency. All machines are equipped with the crabwalk function.

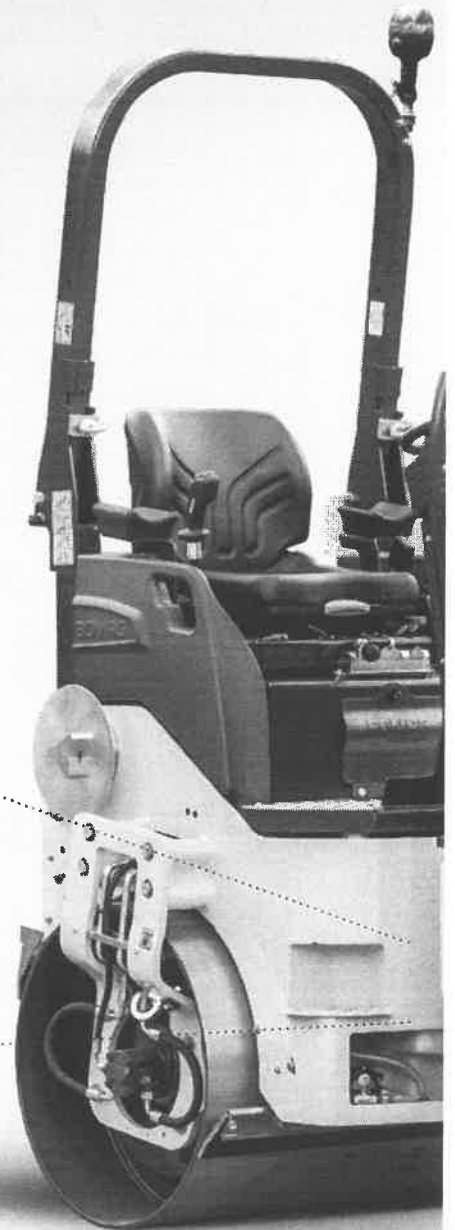

### COMFORTABLE TO OPERATE

The spacious operator's platform with a compact steering wheel has a robust dashboard with large switches. Intuitive operation via a soft-responsive control lever and an excellent view of the drum edges ensure a relaxed working environment.

### CLEARLY SEPARATED

Wind-protected sprinkler nozzles ensure even wetting of the bandages in all conditions.

### EFFECTIVE WORK

Thanks to the ECONOMIZER, compaction is simple and reliable. Unnecessary passes are **avoided**, saving time and money.





**COMFORTABLE WORKING GUARANTEED.**

Ample space and legroom on the operator platform ensure a pleasant workday. The compact steering wheel and the large access steps make getting on and off simple and safe.

## EVERY OPERATOR IS HAPPY TO WORK HERE.

*Light tandem rollers are frequently used by many different operators on a wide variety of construction sites. Therefore, it is particularly important that they intuitively feel at home with the machine and the controls. By developing an abundance of user-oriented features and paying great attention to detail, our engineers make sure that your operators enjoy working with a BOMAG. Because a contented operator is a productive operator.*

### **EASE OF USE COMES AS STANDARD.**

Every function is self-explanatory and intuitive to operate after a very short time. As with every BOMAG tandem roller, the main functions can be selected precisely and error-free by the ergonomic control lever.



Large switches, a compact steering wheel and clearly arranged controls make it easy for any operator to work with a light BOMAG tandem roller.

### **COMFORTABLE COMPACTION WORK.**

The response of the control lever is very pleasant; reversing is modulated and very precise. Drum vibration can be activated selectively for the front or rear only, or for both drums. In tandem with the IVC (Intelligent Vibration Control) system, the exciter system guarantees consistent compaction and reliable operation at all times.



Ample leg room for the operator ensures a comfortable working environment.



## **POWERFUL, ECONOMIC AND EASY TO MAINTAIN.**

*A high level of in-house production, strict quality controls and the enormous demands we place on the longevity of our machines, make BOMAG light tandem rollers uncomplicated endurance runners on your construction site.*



**HIGHEST QUALITY FOR TOUGH EVERYDAY ON-SITE OPERATION.**

- BOMAG-vibration system with proverbial operating reliability.
- Bonnet made of special impact-resistant plastic.
- Reliable and economical Kubota engines.
- Braided cables ensure trouble-free electrics.

**SIMPLE DAILY MAINTENANCE.**

- No lubrication requirements for the entire machine.
- Generous access to the engine compartment, central electrics and water pump.
- Central water and emulsion outlet with filling valve.

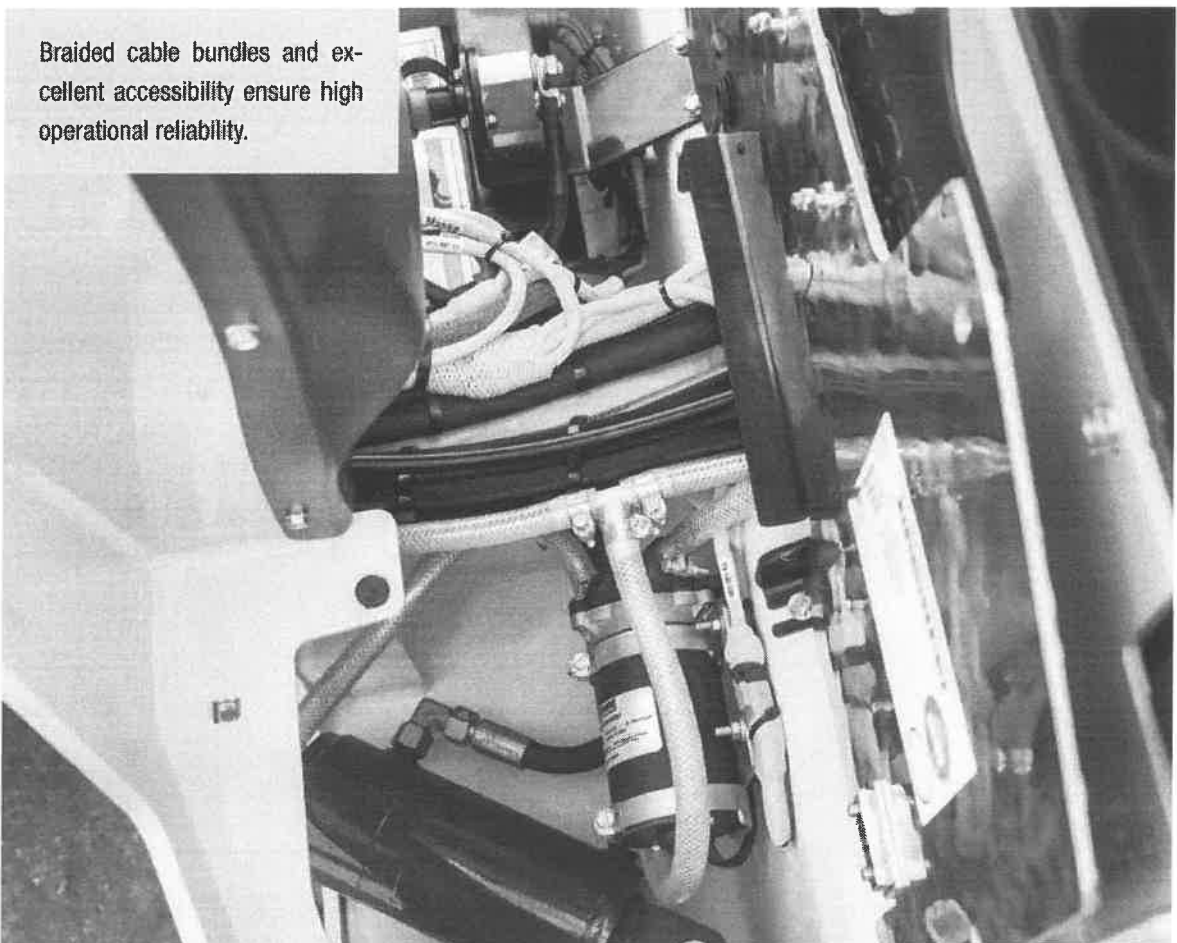

Braided cable bundles and excellent accessibility ensure high operational reliability.

## THE DETAILS MAKE THE DIFFERENCE.

*Impossible is not possible! BOMAG developed their lightweight tandem rollers in collaboration with experienced construction site personnel. Every detail of the machine is well-thought out and tailored to the harsh conditions of construction sites all over the globe. And every single one will make your and your operators' work easier.*

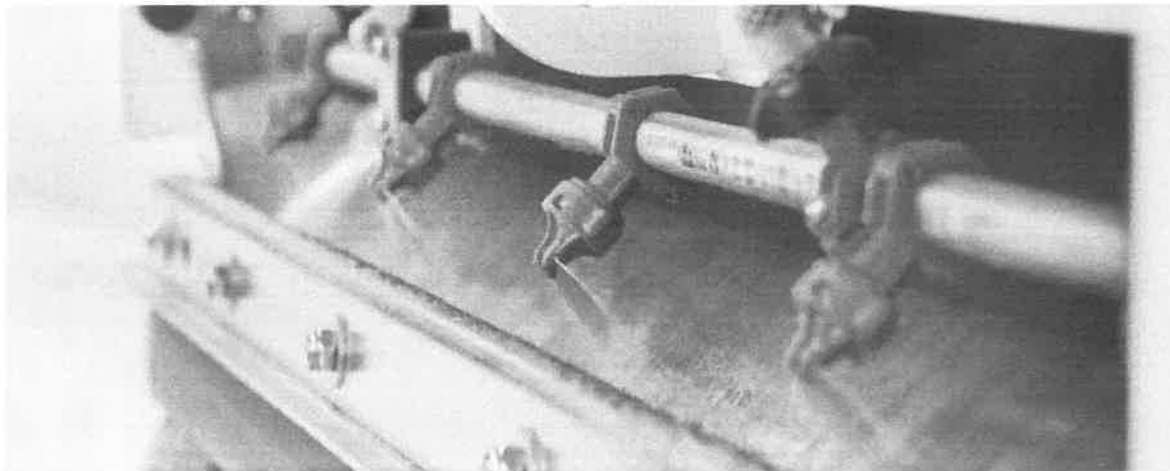

### **FAILSAFE.**

- Pressure sprinkler system with high quality pump, 5-step interval system and large water tank.
- Up to five wind-protected spray nozzles per drum are easily accessible and replaceable.
- 2-filter system to protect against clogged nozzles.

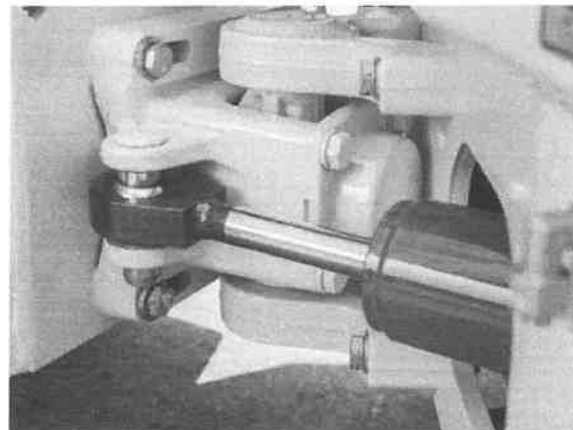
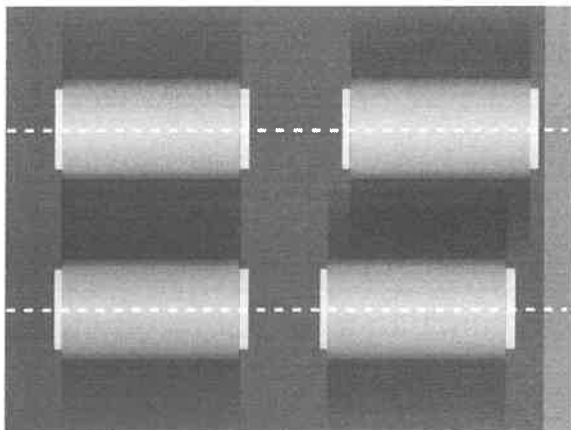

### **AFFORDABLE AND FLEXIBLE.**

- Cost savings with maintenance-free articulated joint without lubrication nipple.
- No welding of articulated joint to frame – easy service access.
- Standard crabwalk with a stepless offset of up to 5 cm to the right for simpler work on edges and corners.



Every machine is supplied with stable and practical lashing rings in sufficient numbers to facilitate securing for transportation.



The single lifting point on each roller is always located at the machine's centre of gravity, simplifying loading and unloading.

## ANYTHING ELSE WE CAN DO FOR YOU?

*If you're in the mood for a few extras, we are more than happy to customize the machine to your individual needs. With a variety of options and packages.*



### **CLEAN EDGES.**

The edge cutting unit can be equipped with various tools for cutting and pressing, and operated with the control lever. Thanks to the quick release connector, the cutter requires no special tools for assembly or disassembly.



### **SPREAD EVENLY.**

Only a unique BOMAG chip spreader offers a uniform distribution pattern with a precisely defined width. Your benefit: No overlap, no wastage, no insufficiency. The spreader can be mounted and removed swiftly and simply with the quick attachment system and laterally adjusted by +/- 20 cm.



#### **OPTIMALLY COMPACTED.**

The BOMAG ECONOMIZER shows the operator the current degree of compaction at all times. LEDs provide permanent information and effectively prevent under or over-compaction. The assistance system saves time and money by avoiding unnecessary passes.

#### **WELL-SHADED.**

The optional folding canopy provides protection from the sun and enhanced safety in tandem with the ROPS, which is then supplied as standard. Folding and unfolding is simple, requiring no operator tools.



#### **EVERYTHING UNDER CONTROL.**

The optionally available double control levers ensure enhanced driving and operating comfort. In conjunction with the robust seat sliding function, they simplify manoeuvring and the operator's work. Both control levers are equipped with operation switches for the horn, vibration and, when required, for edge cutters.

## EFFORTLESS COMPETENCE EVERY TIME.



Whether for asphalt or earthworks – compaction is a breeze with BOMAG tandem rollers. The self-explanatory operation of all the functions and optimal performance of the machine are decisive in ensuring the highest quality at every construction site.



#### **EASY AND SMOOTH COMPACTION.**

In order to increase flexibility in tight spaces, BOMAG offers rollers with clear-sided drums. The drums are only suspended on one side and off-centre. As a result, they can compact cleanly right up to high walls of e.g. buildings and other boundaries.

#### **SURFACES OF THE HIGHEST QUALITY.**

The asphalt surface quality can be improved considerably by the use of BOMAG light combination rollers on the site. The rolling and kneading effect of the rubber wheels pulls bitumen to the surface and achieves maximum sealing of the asphalt layer. The tyres' adaptability also make clean compaction on transitions and edges possible.





## **ALWAYS THE RIGHT CHOICE. BOMAG ORIGINAL PARTS AND SERVICE.**

*When deciding on your machine, you deliberately opted for a BOMAG. To ensure the long-term performance of your equipment, you can also rely on the tried and trusted quality of BOMAG's service and genuine parts.*

### **ALWAYS RELIABLE.**

When you purchase a BOMAG machine, professional service and high availability of genuine parts come as standard. With 12 foreign subsidiaries and more than 500

dealers in over 120 countries, we are reliably at your service throughout the world. No matter where your machine is in use, we won't let you down!



The optimised access to all machine components makes daily maintenance easy for the operator. And when maintenance is straightforward it gets done regularly.

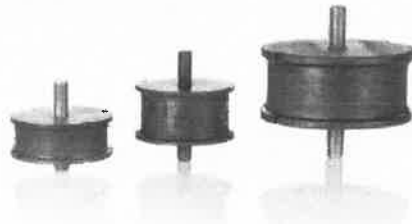

#### **INIMITABLY BOMAG.**

BOMAG Genuine Parts are tailored precisely to your machine and characterised by their outstanding reliability and proven quality. Unlike replicas, they fulfil the highest quality standards in terms of functionality and durability, so your BOMAG stays a BOMAG.



#### **WHAT ARE YOU WAITING FOR?**

BOMAG Service Kits are configured individually for your BOMAG by our service professionals, and contain all the components necessary for a professional service in one convenient package. This not only saves you time, but money as well – up to 15% savings compared to single part orders.



#### **ALWAYS AT THE READY.**

BOMAG Water Spray Kits are specially designed for BOMAG tandem rollers to replace sprinkler parts quickly and efficiently on site. In their handy transport case they can be taken anywhere, and components immediately be replaced as necessary so the machine is quickly up and running again.



#### **YOUR PLUS IN RELIABILITY.**

BOMAG PartnerPlus for peace of mind at a calculable price. You decide on the scope of service yourself, and select from a comprehensive range of maintenance, repair, and optional expansion packages. With the BOMAG PartnerPlus program, you stay flexible and increase the operational reliability of your BOMAG.

## MODEL OVERVIEW.

*BOMAG offers the right machine for every application. Select the roller and equipment that is perfectly suited to you, your requirements and your company from 14 different models.*



BW 100/120: The multi-talents from 2.3 to 3.7 t.



BW 80/90/100: The light line up to 1.8 t.

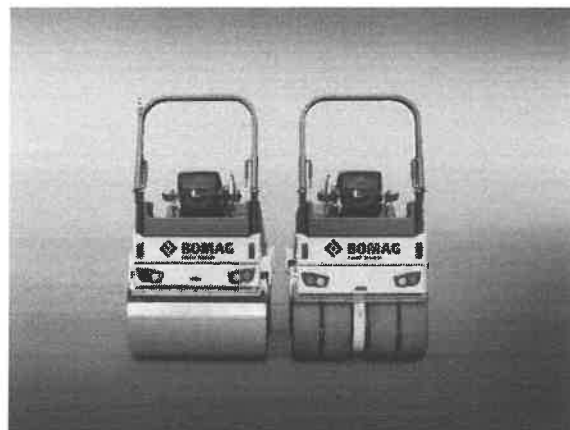

BW 135/138: The heavyweights from 3.9 to 4.3 t.

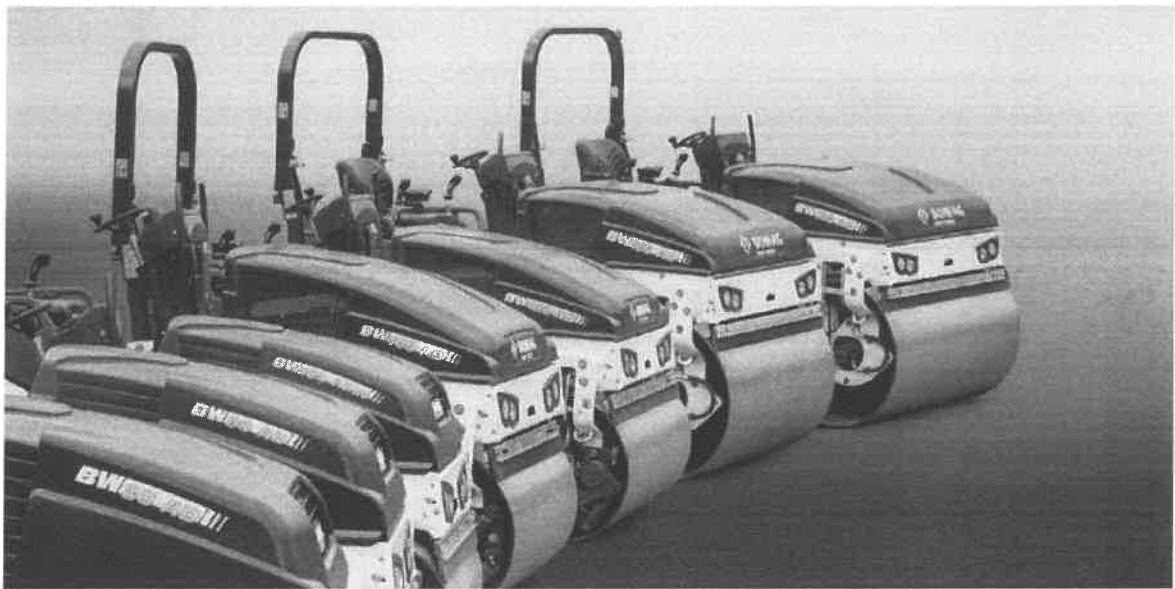

Modelltypen	Operating weight approx. [t]*	Working width [mm]	Power [kW]
<b>BW 80 AD</b>	1.550	800	15,1
<b>BW 90 AD</b>	1.600	900	15,1
<b>BW 90 SC (side clearance)</b>	1.650	960	15,1
<b>BW 100 ADM</b>	1.650	1.000	15,1
<b>BW 100 SC (side clearance)</b>	1.700	1.060	15,1
<b>BW 100 ACM (combination roller)</b>	1.700	1.000	15,1
<b>BW 100 SCC (combination roller, side clearance)</b>	1.700	1.060	15,1
<b>BW 100 AD</b>	2.500	1.000	24,3
<b>BW 100 AC (combination roller)</b>	2.300	1.000	24,3
<b>BW 120 AD</b>	2.700	1.200	24,3
<b>BW 120 AC (combination roller)</b>	2.500	1.200	24,3
<b>BW 135 AD</b>	3.900	1.300	33,3
<b>BW 138 AD</b>	4.300	1.380	33,3
<b>BW 138 AC (combination roller)</b>	4.100	1.380	33,3

\*) Approximate operating weights with basic equipment. The actual weight subject to specification. Subject to technical alterations. Machines may be shown with optional equipment.



## **PERFECTION IS NO ACCIDENT.**

Our entire expertise is also embodied in every light BOMAG tandem roller. Down to the tiniest detail. So that you can put all your experience into your work. The result: Visible success, every time.



**Head Office:**

**BOMAG**  
Hellerwald  
56154 Boppard  
GERMANY  
Tel. +49 6742 100-0  
info@bomag.com

**BOMAG Maschinen-  
handels-gesellschaft m.b.H.**  
Klausenweg 664  
2534 Alland  
AUSTRIA  
Tel. +43 2258 20202  
austria@bomag.com

**BOMAG MARINI EQUIPAMENTOS LTDA.**  
Avenida Clemente Cifali, 530  
Distrito Industrial Ritter  
Cachoeirinha - RS  
BRAZIL  
ZIP code 94835-225  
Tel. +55 51 2125-6642  
brasil@bomag.com

**BOMAG (CANADA), INC.**  
2233 Argenta Road, East Tower  
Suites 302  
LSN 2X7 Mississauga, ON  
CANADA  
Tel. +1 800 782 6624  
canada@bomag.com

**BOMAG (CHANGZHOU)**  
Construction Machinery Co., Ltd.  
No. 66 Bopa Road  
Xuejia Town  
Xinbei District  
Changzhou 213125  
CHINA  
Tel: +86 519 88585566  
china@bomag.com

**BOMAG India Pvt Ltd**  
Unit No. 614, B Wing, 6th Floor  
Kanakia Wall Street  
Chakala Andheri Kuria Road Andheri East  
Mumbai 400 093 Maharashtra  
INDIA  
Tel.: +91 8657492418  
india@bomag.com

**BOMAG France S.A.S.**  
2, Avenue du Général de Gaulle  
91170 Viry-Châtillon  
FRANCE  
Tel. +33 1 69578600  
france@bomag.com

**BOMAG (GREAT BRITAIN), LTD.**  
Sheldon Way  
Larkfield, Aylesford  
Kent ME20 6SE  
GREAT BRITAIN  
Tel. +44 1622 716611  
gb@bomag.com

**BOMAG Italia Srl.**  
Via Roma 50  
48011 Alfonsine  
ITALY  
Tel. +39 0544 864235  
italy@bomag.com

**FAYAT BOMAG Polska Sp. z o.o.**  
Ul. Szyszkowa 62  
02-285 Warszawa  
POLAND  
Tel. +48 22 482 04 00  
poland@bomag.com

**FAYAT BOMAG RUS OOO**  
141400, RF, Moscow region  
Khimki, Klayaznia block, h. 1-g  
RUSSIA  
Tel. +7 (495) 287 92 90  
russia@bomag.com

**BOMAG GmbH**  
300 Beach Road  
The Concourse, #18-06  
Singapore 199555  
SINGAPORE  
Tel. +65 6 284 1277  
singapore@bomag.com

**BOMAG Americas, Inc.**  
125 Blue Granite Parkway  
Ridgeway SC 29130  
U.S.A.  
Tel. +1 803 3370700  
usa@bomag.com

