

09/23/21 12:30:02  
MV Purchasing Division

## **Sealed Bid: Meal Delivery Carts**

**Buyer: Jessica Hovanec**

**Solicitation No.: CRFQ 0613 VNF2200000005**

**Bid Opening Date: September 23, 2021**

**Bid Opening Time: 1:30 pm**

**Fax Number: 719-542-8857**



Department of Administration  
Purchasing Division  
2019 Washington Street East  
Post Office Box 50130  
Charleston, WV 25305-0130

State of West Virginia  
Centralized Request for Quote  
Equipment

Proc Folder: 935182		Reason for Modification:	
Doc Description: Meal Delivery Carts			
Proc Type: Central Purchase Order			
Date issued	Solicitation Closes	Solicitation No	Version
2021-09-09	2021-09-23 13:30	CRFQ 0613 VNF2200000005	1

**BID RECEIVING LOCATION**

BID CLERK  
DEPARTMENT OF ADMINISTRATION  
PURCHASING DIVISION  
2019 WASHINGTON ST E  
CHARLESTON WV 25305  
US

**VENDOR**

Vendor Customer Code:  
Vendor Name: Pueblo Hotel Supply  
Address: 170  
Street: Greenhorn Dr  
City: Pueblo  
State: CO Country: USA Zip: 81004  
Principal Contact: Kayla Price  
Vendor Contact Phone: 719-755-0792 Extension:

**FOR INFORMATION CONTACT THE BUYER**  
Jessica L Hovanec  
304-558-2314  
jessica.l.hovanec@wv.gov

Vendor Signature X *Kayla Price* FEIN# 84-0702763 DATE 9/23/21

All offers subject to all terms and conditions contained in this solicitation

**ADDITIONAL INFORMATION**  
The West Virginia Purchasing Division is soliciting bids on behalf of the West Virginia Veterans Nursing Facility located at 1 Freedoms Way, Clarksburg, WV 26301, to establish a one-time purchase of four (4) Meal Delivery Carts per the Specifications and Terms and Conditions as attached hereto.

INVOICE TO		SHIP TO	
DIVISION OF VETERANS AFFAIRS 1 FREEDOMS WAY CLARKSBURG WV US		VETERAN'S NURSING FACILITY 1 FREEDOMS WAY CLARKSBURG WV US	

Line	Comm Ln Desc	Qty	Unit Issue	Unit Price	Total Price
1	Dish Carts	4.00000	EA	\$3,963.25	\$15,853.00

Comm Code	Manufacturer	Specification	Model #
48100000	Lakeside	Tray Delivery Cart	5620

**Extended Description:**  
Meal Delivery Carts, stainless steel, 20-Tray single door, Alluserv TC12-20 Elite 480TC1220 or equal.

INVOICE TO		SHIP TO	
DIVISION OF VETERANS AFFAIRS 1 FREEDOMS WAY CLARKSBURG WV US		VETERAN'S NURSING FACILITY 1 FREEDOMS WAY CLARKSBURG WV US	

Line	Comm Ln Desc	Qty	Unit Issue	Unit Price	Total Price
2	Delivery	4.00000	EA	\$0.00	\$0.00

Comm Code	Manufacturer	Specification	Model #
78121603	Delivery		

**Extended Description:**  
Delivery to 1 Freedom Way, Clarksburg WV 26301

**SCHEDULE OF EVENTS**

Line	Event	Event Date
1	Technical Questions due on September 14, 2021 at 10:00 AM	2021-09-14

	Document Phase	Document Description	Page
VNF2200000005	Draft	Meal Delivery Carts	3

**ADDITIONAL TERMS AND CONDITIONS**

See attached document(s) for additional Terms and Conditions

**DESIGNATED CONTACT:** Vendor appoints the individual identified in this Section as the Contract Administrator and the initial point of contact for matters relating to this Contract.

Kayla Price - Sales Representative  
 (Name, Title)  
 Kayla Price - Sales Representative

170 Greenhorn Dr Pueblo, CO 81004  
 (Printed Name and Title)  
 170 Greenhorn Dr Pueblo, CO 81004

719-755-0792 / 719-542-8857  
 (Address)  
 719-755-0792 / 719-542-8857

kayla@gogradys.com  
 (Phone Number) / (Fax Number)  
 kayla@gogradys.com

(email address)

**CERTIFICATION AND SIGNATURE:** By signing below, or submitting documentation through wvOASIS, I certify that: I have reviewed this Solicitation in its entirety; that I understand the requirements, terms and conditions, and other information contained herein; that this bid, offer or proposal constitutes an offer to the State that cannot be unilaterally withdrawn; that the product or service proposed meets the mandatory requirements contained in the Solicitation for that product or service, unless otherwise stated herein; that the Vendor accepts the terms and conditions contained in the Solicitation, unless otherwise stated herein; that I am submitting this bid, offer or proposal for review and consideration; that I am authorized by the vendor to execute and submit this bid, offer, or proposal, or any documents related thereto on vendor's behalf; that I am authorized to bind the vendor in a contractual relationship; and that to the best of my knowledge, the vendor has properly registered with any State agency that may require registration.

By signing below, I further certify that I understand this Contract is subject to the provisions of West Virginia Code § 5A-3-62, which automatically voids certain contract clauses that violate State law.

Pueblo Hotel Supply  
(Company)

Kayla Price - Sales Representative  
(Authorized Signature) (Representative Name, Title)

Kayla Price - Sales Representative  
(Printed Name and Title of Authorized Representative)

9/23/21  
(Date)

Phone: 719-755-0792 / Fax: 719-542-8857  
(Phone Number) (Fax Number)

**Exhibit A  
Pricing Page**

LINE	DESCRIPTION	UNIT PRICE	TOTAL COST
1	Four (4) Dish Carts, per specifications. <u>(INSERT MAKE AND MODEL HERE):</u> Lakeside Model# 5620	\$3,963.25	\$15,853.00
2	Delivery of All Four (4) Dish Carts	\$0.00	\$0.00
<b>OVERALL TOTAL COST:</b>			<b>\$15,853.00</b>

Vendor:	Pueblo Hotel Supply		
Address:	170 Greenhorn Dr		
	Pueblo, CO 81004		
Phone:	Office: 719-755-0792	Cell:	719-542-8853
Email:	kayla@gogradys.com		
Name:	Kayla Price		
Signature:	<i>Kayla Price</i>		

STATE OF WEST VIRGINIA  
Purchasing Division  
**PURCHASING AFFIDAVIT**

**CONSTRUCTION CONTRACTS:** Under W. Va. Code § 5-22-1(i), the contracting public entity shall not award a construction contract to any bidder that is known to be in default on any monetary obligation owed to the state or a political subdivision of the state, including, but not limited to, obligations related to payroll taxes, property taxes, sales and use taxes, fire service fees, or other fines or fees.

**ALL CONTRACTS:** Under W. Va. Code §5A-3-10a, no contract or renewal of any contract may be awarded by the state or any of its political subdivisions to any vendor or prospective vendor when the vendor or prospective vendor or a related party to the vendor or prospective vendor is a debtor and: (1) the debt owed is an amount greater than one thousand dollars in the aggregate; or (2) the debtor is in employer default.

**EXCEPTION:** The prohibition listed above does not apply where a vendor has contested any tax administered pursuant to chapter eleven of the W. Va. Code, workers' compensation premium, permit fee or environmental fee or assessment and the matter has not become final or where the vendor has entered into a payment plan or agreement and the vendor is not in default of any of the provisions of such plan or agreement.

**DEFINITIONS:**

**"Debt"** means any assessment, premium, penalty, fine, tax or other amount of money owed to the state or any of its political subdivisions because of a judgment, fine, permit violation, license assessment, defaulted workers' compensation premium, penalty or other assessment presently delinquent or due and required to be paid to the state or any of its political subdivisions, including any interest or additional penalties accrued thereon.

**"Employer default"** means having an outstanding balance or liability to the old fund or to the uninsured employers' fund or being in policy default, as defined in W. Va. Code § 23-2c-2, failure to maintain mandatory workers' compensation coverage, or failure to fully meet its obligations as a workers' compensation self-insured employer. An employer is not in employer default if it has entered into a repayment agreement with the Insurance Commissioner and remains in compliance with the obligations under the repayment agreement.

**"Related party"** means a party, whether an individual, corporation, partnership, association, limited liability company or any other form or business association or other entity whatsoever, related to any vendor by blood, marriage, ownership or contract through which the party has a relationship of ownership or other interest with the vendor so that the party will actually or by effect receive or control a portion of the benefit, profit or other consideration from performance of a vendor contract with the party receiving an amount that meets or exceeds five percent of the total contract amount.

**AFFIRMATION:** By signing this form, the vendor's authorized signer affirms and acknowledges under penalty of law for false swearing (W. Va. Code §61-5-3) that: (1) for construction contracts, the vendor is not in default on any monetary obligation owed to the state or a political subdivision of the state, and (2) for all other contracts, that neither vendor nor any related party owe a debt as defined above and that neither vendor nor any related party are in employer default as defined above, unless the debt or employer default is permitted under the exception above.

**WITNESS THE FOLLOWING SIGNATURE:**

Vendor's Name: Pueblo Hotel Supply

Authorized Signature: Kayla Price Date: 9/23/21

State of Colorado

County of Pueblo, to-wit:

Taken, subscribed, and sworn to before me this 23<sup>rd</sup> day of September, 2021.

My Commission expires May 3<sup>rd</sup>, 2024.

HEIDI S GOLIK  
NOTARY PUBLIC  
STATE OF COLORADO  
NOTARY ID# 20184016655  
MY COMMISSION EXPIRES MAY 03, 2024



NOTARY PUBLIC Heidi S Golik



# Quote

09/23/2021

**To:**  
West Virginia Department of  
Administration  
Jessica Hovanec  
304-558-2314 (Contact)

**Project:**  
West Virginia Dept of  
Administration - CRFQ 0613  
VNF2200000005

**From:**  
Pueblo Hotel Supply  
Kayla Price  
170 Greenhorn Drive  
170 Greenhorn Drive.  
Pueblo, CO 81004  
(719)542-8853  
719-924-3198 (Contact)

Job Reference Number: OPP3896

All quotes are valid for 15 days. If ordering after 15 days, quote may be subject to price increases.

**NOTES:**

**THIS QUOTE INCLUDES STANDARD DELIVERY TO LOADING DOCK ONLY.  
THIS QUOTE DOES NOT INCLUDE LIFTGATE, INSIDE DELIVERY, ASSEMBLY,  
OR INSTALLATION.  
WE ARE NOT RESPONSIBLE FOR VERIFYING MEASUREMENTS OR UTILITIES  
PRIOR TO PURCHASE.  
LEAD TIMES ARE SUBJECT TO CHANGE BASED UPON FACTORY  
PRODUCTION.**

Item	Qty	Description	Sell	Sell Total
1	4 ea	<b>MEAL TRAY DELIVERY CART</b> Lakeside Manufacturing Model No. 5620 Elite Series™ Tray Delivery Cart, enclosed-type, single door, single compartment, (20) 14" x 18" or 15" x 20" tray capacity, (2) trays per ledge, 5-1/4" spacing, 270° door swing, corner bumpers, (2) 6" fixed and (2) 6" swivel Lake-Glide® casters, 2" wide cushion tread tires, 200/300 stainless steel construction, NSF, Made in USA Dimensions 64(h) x 33(w) x 36.75(d)	\$3,655.88	\$14,623.52
	4 ea	6" casters (2 swivel, 2 fixed), standard		
	4 ea	09303 Transport door latch	\$102.74	\$410.96
	4 ea	Full perimeter bumper	\$204.63	\$818.52
<b>THE CURRENT LEAD TIME FOR THIS ITEM IS 4-6 WEEKS.</b>				
Class 125		Weight: 1056 lbs total		Cube: 166.4
			<b>ITEM TOTAL:</b>	<b>\$15,853.00</b>
			Merchandise	\$15,853.00
			Freight	
			Total	\$15,853.00



**Pueblo Hotel Supply**

**09/23/2021**

Any and all damaged item(s) should be marked as such on delivery ticket and or refused and Grady's Restaurant and Bar Equipment should be notified immediately as to the extent of the damage so that we can address and work toward a solution immediately.

All packaging materials must be retained from damaged item(s) for freight inspector/adjuster claim.

Custom fabricated item(s) are not returnable. Buy-out item(s) may be returnable less the manufacturer's restocking fee, freight too and from, as well as any damages that may be incurred. The returned item(s) must be new and unused.

Credits for returned item(s) will only be given once the factory has issued credit to Grady's Restaurant and Bar Equipment

Freight is not included unless otherwise specified.

Price does not included fees, taxes, bond, permit, or licenses unless otherwise specified.

**WOSB**

Woman-Owned  
Small Business

Acceptance: \_\_\_\_\_ Date: \_\_\_\_\_

Printed Name: \_\_\_\_\_

Project Grand Total: \$15,853.00



Item # \_\_\_\_\_  
Quantity \_\_\_\_\_

# Enclosed Tray Trucks

## Elite Series™ High Capacity - Stainless Steel



Model 5628



Models 5618, 5620, 5624  
5628, 5632

### Designed For Delivery Of Insulated Meal Trays.

- Accommodates 14" x 18" or 15" x 20" size trays, two per ledge.
- Doors open 270° for unobstructed access.
- Paddle latch door catch assures positive door closure and convenient one-hand opening.
- Sturdy welded tubular push handle for increased maneuverability.
- Cart body and removable stainless steel ledge panels are easily cleaned and sanitized.
- Base corner bumpers protect walls, furnishings and doors.
- Compartment floor drains facilitate interior cleaning.
- Increased capacity and visibility during transport.

Spec. #

A/A #

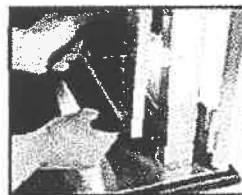
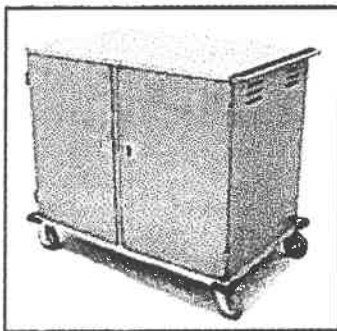

Removable Ledge Panels

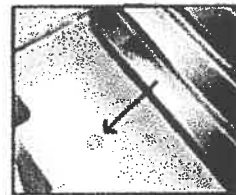

Compartment Floor Drain



Two Trays Per Ledge

### Specifications

Unit shall be of stainless steel welded and riveted construction to accommodate 14" x 18" (356 x 457 mm) or 15" x 20" (381 x 508 mm) trays. Material thickness shall be of 16 gauge for top and floor/base, 20 gauge for sides and back. Doors shall be of 20 gauge insulated double-pan design, and shall be mounted to unit frame with two each 3" (76 mm) heavy-duty stainless steel hinges. Hinges shall be welded to door and unit frame. Doors shall swing 270° to provide full access to tray compartments, and shall be easily removable by lifting off of hinges. Door latches shall be recessed paddle design. Tray ledges shall be 18 gauge stainless steel angle, welded to an 18 gauge stainless steel frame panel at 5 1/2" (133 mm) spacing. Ledge panels shall be shall accommodate both 14" x 18" or 15" x 20" trays (two trays per ledge), and shall be removable for easy cleaning. Tray compartments shall have vents on end panels and shall have perforated center floor drains. Unit base shall have 1 1/2" (32 mm) thick extruded PVC rounded bumpers mounted to corners. A 1" tubular push handle shall be welded to one end of the unit. Unit shall have four each extra-load plate type casters, two fixed and two swivel, mounted to a 14 gauge stainless steel dolly on unit base. Swivel casters shall have shielded ball bearing races and zerk fittings for lubrication of bearings. Caster wheels shall be 6" (152 mm) diameter with 2" wide, non-marking, rounded cushion tread. Unit shall be NSF listed.

Lakeside Manufacturing, Inc.

4900 West Electric Avenue • West Milwaukee, WI 53219 U.S.A.

800-558-8565 • 414-902-6400 • Fax 414-902-6446 • info@eLakeside.com • www.eLakesideFoodservice.com

**Models**  
5618, 5620  
5624, 5628  
5632

# Enclosed Tray Trucks

## Elite Series™ High Capacity - Stainless Steel

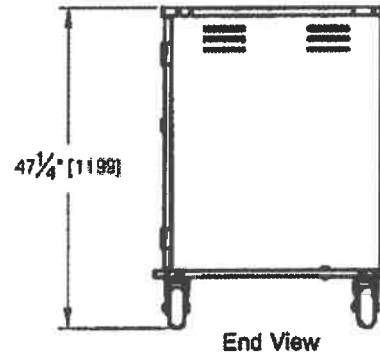
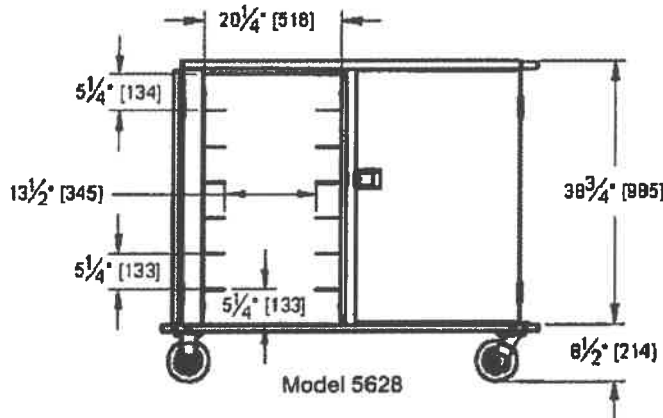
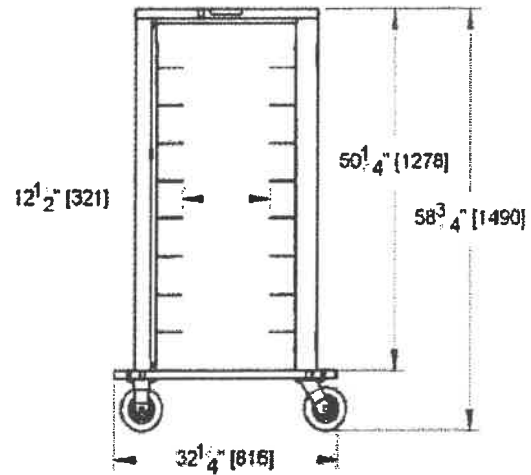
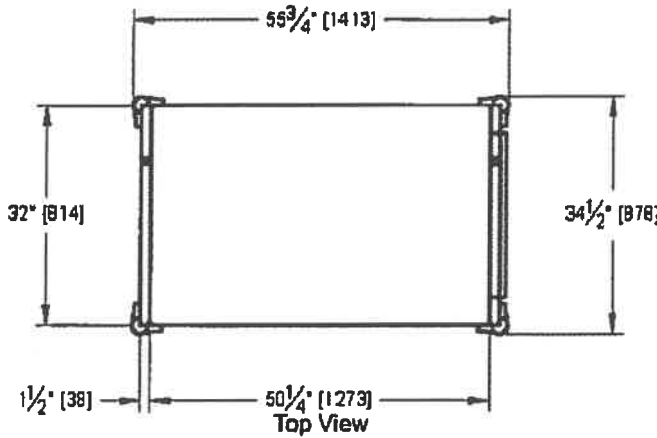

Spec. #

AIA #

**Model Information:**

Model	Tray Capacity	Ledge Spacing	Compartments/Trays Per Ledge	Overall Size			Casters		Ship Wt. Lbs. (Kg)
				W	D	H	Type	Dia.	
5618	18	5 1/4 (133)	1 / 2	33" (838)	36 1/2" (933)	58 3/4" (1492)	2 Fixed 2 Swivel	6" (152)	198 (90)
5620	20	5 1/4 (133)	1 / 2	33" (838)	36 1/2" (933)	64" (1626)	2 Fixed 2 Swivel	6" (152)	218 (99)
5624	24	5 1/4 (133)	2 / 2	55 3/4" (1416)	34 3/4" (876)	42" (1094)	2 Fixed 2 Swivel	6" (152)	305 (139)
5628	28	5 1/4 (133)	2 / 2	55 3/4" (1416)	34 3/4" (876)	47 1/4" (1213)	2 Fixed 2 Swivel	6" (152)	335 (152)
5632	32	5 1/4 (133)	2 / 2	55 3/4" (1416)	34 3/4" (876)	52 1/2" (1334)	2 Fixed 2 Swivel	6" (152)	365 (166)

*Dimensions in ( ) denote metric millimeters, unless otherwise noted.*

**Optional Accessories**

- Custom ledge spacing
- Transport door latch
- Full perimeter bumper
- 8" casters
- 2" top rail (3 sides)
- 6 each 6" casters (4 swivel, 2 fixed)
- Creased compartment floor (for drain)
- Menu card holder
- Towing hitch



**Lakeside Manufacturing, Inc.**  
4900 West Electric Avenue • West Milwaukee, WI 53219 U.S.A.  
800-558-8565 • 414-902-6400 • Fax 414-902-6448  
info@eLakeside.com • www.eLakesideFoodservice.com