



The following documentation is an electronically-submitted vendor response to an advertised solicitation from the *West Virginia Purchasing Bulletin* within the Vendor Self-Service portal at wvOASIS.gov. As part of the State of West Virginia's procurement process, and to maintain the transparency of the bid-opening process, this documentation submitted online is publicly posted by the West Virginia Purchasing Division at WVPurchasing.gov with any other vendor responses to this solicitation submitted to the Purchasing Division in hard copy format.

Header

List View

General Information | [Contact](#) | [Default Values](#) | [Discount](#) | [Document Information](#) | [Clarification Request](#)

Procurement Folder: 846036

SO Doc Code: CRFQ

Procurement Type: Central Master Agreement

SO Dept: 0803

Vendor ID: VS0000037852

SO Doc ID: DOT2100000108

Legal Name: SANY America, Inc

Published Date: 4/12/21

Alias/DBA:

Close Date: 4/14/21

Total Bid: \$1,905,170.00

Close Time: 13:30

Response Date: 04/14/2021

Status: Closed

Response Time: 12:30

Solicitation Description: ADDENDUM NO_4 Motor grader
all wheel dr.

Responded By User ID: tschanz

Total of Header Attachments: 1

Total of All Attachments: 1

First Name: Tom

Last Name: Schanz

Email: tschanz@sanyamerica.c

Phone: 404-230-3728



Department of Administration
 Purchasing Division
 2019 Washington Street East
 Post Office Box 50130
 Charleston, WV 25305-0130

**State of West Virginia
 Solicitation Response**

Proc Folder: 846036
Solicitation Description: ADDENDUM NO_4 Motor grader all wheel dr.
Proc Type: Central Master Agreement

Solicitation Closes	Solicitation Response	Version
2021-04-14 13:30	SR 0803 ESR04122100000006984	1

VENDOR
 VS0000037852
 SANY America, Inc

Solicitation Number: CRFQ 0803 DOT2100000108
Total Bid: 1905170
Response Date: 2021-04-14
Response Time: 12:30:45
Comments: N/A

FOR INFORMATION CONTACT THE BUYER
 John W Estep
 304-558-2566
 john.w.estep@wv.gov

Vendor Signature X	FEIN#	DATE
---------------------------	--------------	-------------

All offers subject to all terms and conditions contained in this solicitation

Line	Comm Ln Desc	Qty	Unit Issue	Unit Price	Ln Total Or Contract Amount
1	Motor grader articulated all wheel drive	10.00000	EA	190517.000000	1905170.00

Comm Code	Manufacturer	Specification	Model #
22101502			

Commodity Line Comments: SANY America currently has all 10 motor graders available for delivery. 90 day lead time due to attachment supplier constraints

SANY America does not comply with the following restrictions:

Extended Description:

Motor grader articulated all wheel drive w/reversible front mounted trip/plow



Department of Administration
 Purchasing Division
 2019 Washington Street East
 Post Office Box 50130
 Charleston, WV 25305-0130

State of West Virginia
 Centralized Request for Quote
 Equipment

Proc Folder: 846036		Reason for Modification:	
Doc Description: ADDENDUM NO_1 Motor grader all wheel dr.		ADDENDUM NO_1 Attach Pre-Bid Sign in Sheets	
Proc Type: Central Master Agreement			
Date Issued	Solicitation Closes	Solicitation No	Version
2021-03-25	2021-04-08 13:30	CRFQ 0803 DOT2100000108	2

BID RECEIVING LOCATION

BID CLERK
 DEPARTMENT OF ADMINISTRATION
 PURCHASING DIVISION
 2019 WASHINGTON ST E
 CHARLESTON WV 25305
 US

VENDOR

Vendor Customer Code: VS0000037852
Vendor Name :SANY America Inc
Address : 318 Cooper Circle
Street :
City : Peachtree City
State : GA **Country :** USA **Zip :** 30269
Principal Contact : Tom Schanz
Vendor Contact Phone: 404-230-3728 **Extension:**

FOR INFORMATION CONTACT THE BUYER
 John W Estep
 304-558-2566
 john.w.estep@wv.gov

Vendor Signature X  **FEIN#** 20-5048542 **DATE** 4/14/21

All offers subject to all terms and conditions contained in this solicitation

ADDITIONAL INFORMATION

ADDENDUM NO_1

Addendum No_1 issued to publish and distribute the attached information to the vendor Community

REQUEST FOR QUOTATION:

The West Virginia Purchasing Division is soliciting bids on behalf of West Virginia Division of Highways to establish an open-end contract for a Motor Grader Articulated All Wheel Drive w/ Reversible Front Mounted Trip/Plow John Deere 672 AWD or equal. Per the bid requirements, specifications, terms and conditions attached to this solicitation.

INVOICE TO	SHIP TO
DIVISION OF HIGHWAYS EQUIPMENT DIVISION RT 33 83 BRUSHY ROAD CROSSING, PO BOX 610 BUCKHANNON WV 26201 US	DIVISION OF HIGHWAYS EQUIPMENT DIVISION 83 BRUSHY FORK RD CROSSING BUCKHANNON WV 26201 US

Line	Comm Ln Desc	Qty	Unit Issue	Unit Price	Total Price
1	Motor grader articulated all wheel drive	10.00000	EA		

Comm Code	Manufacturer	Specification	Model #
22101502			

Extended Description:

Motor grader articulated all wheel drive w/reversible front mounted trip/plow

SCHEDULE OF EVENTS

<u>Line</u>	<u>Event</u>	<u>Event Date</u>
1	Pre-Bid Meeting at 12:00pm @ Buckhannon	2021-03-24
2	Tech Questions due by 10:00am	2021-04-01

SOLICITATION NUMBER: CRFQ DOT2100000108

Addendum Number: 1

The purpose of this addendum is to modify the solicitation identified as CRFQ DOT2100000108 (“Solicitation”) to reflect the change(s) identified and described below.

Applicable Addendum Category:

- Modify bid opening date and time
- Modify specifications of product or service being sought
- Attachment of vendor questions and responses
- Attachment of pre-bid sign-in sheet
- Correction of error
- Other

Additional Documentation:

1. Attach Pre-Bid Sign in Sheets

Terms and Conditions:

1. All provisions of the Solicitation and other addenda not modified herein shall remain in full force and effect.
2. Vendor should acknowledge receipt of all addenda issued for this Solicitation by completing an Addendum Acknowledgment, a copy of which is included herewith. Failure to acknowledge addenda may result in bid disqualification. The addendum acknowledgement should be submitted with the bid to expedite document processing.

Pre-Bid Sign-In Sheet

Solicitation Number: CRFQ I

Date of Pre-Bid Meeting: March 2

Location of Prebid Meeting: Buck

Please Note:

Vendors must sign-in on this sheet to verify attendance at the Pre-Bid meeting.

Failure to legibly sign in may be grounds for declaring a vendor ineligible to bid.

For further verification, please also provide a business card if possible.

Firm Represented:*	Rep. Name (Printed):	Firm Address:	Telephone #:	Fax #:
WVDOH	Pam Hall	83 Brushy Fork Rd. Crossin Buckhannon	304-471-0139	
WVDOH	JD Haller		304-471-0141	
WVDOH	Kristy James	1900 Kanawha Blvd E. Bldg 5 Rm 220 Charleston, WV 25305	304-44-7104	
WVDOH	Todd Campbell	83 Brushy Fork Rd. Crossin Buckhannon	304-997-5916	

***One Vendor Per Representative - No one individual is permitted to represent more than one vendor at the pre-bid meeting. If an individual attempts to represent two or more vendors, they will be required to select one vendor to which their attendance will be attributed. If an individual is selected to represent a vendor but does not attend the pre-bid meeting, their attendance will be deemed to have not attended the pre-bid meeting unless another individual attended on their behalf.**

Pre-Bid Sign-In Sheet

Solicitation Number: CRFQ 1
 Date of Pre-Bid Meeting: March 2
 Location of Prebid Meeting: Buck

Please Note:

Vendors must sign-in on this sheet to verify attendance at the Pre-Bid meeting.
 Failure to legibly sign in may be grounds for declaring a vendor ineligible to bid.
 For further verification, please also provide a business card if possible.

Firm Represented:*	Rep Name (Printed):	Firm Address:	Telephone #:	Fax #:
Boyd CAT	MATT CONNOR	P.O. Box 2427 CHARLESTON, WV 25329	(304) 543-5406	(304) 59-4406
UN TRACTOR COMPANY	GARY GRADE	P.O. BOX 473 CHARLESTON WV 25302	304-346 5301	304-346 5305
Leslie Equipment Co.	Bo Kester	2098 Lillian Lane Pleasant Valley WV 26554	304-534-5454	304-534-5888
Appalachian Equipment Solutions	Justin Phillip	1750 Harbors Creek Rd Jane Lee WV 26378	304-786-9587	
SANY America	TOM Scharz	318 Cooper Circle Decatur City, GA 30219	404-230-3227	
Henke Manufacturing	Paul Refo	3070 Wilson Ave Waverly KS 66167	717-891-4725	

***One Vendor Per Representative - No one individual is permitted to represent more than one vendor at the pre-bid meeting. If an individual attempts to represent two or more vendors, they will be required to select one vendor to which their attendance will be attributed. Failure to do so will be deemed to have not attended the pre-bid meeting unless another individual attended on their behalf.**

Pre-Bid Sign-In Sheet

Solicitation Number: CRFQ

Date of Pre-Bid Meeting: March 2

Location of Prebid Meeting: Buck

Please Note:

Vendors must sign-in on this sheet to verify attendance at the Pre-Bid meeting. Failure to legibly sign in may be grounds for declaring a vendor ineligible to bid. For further verification, please also provide a business card if possible.

Firm Represented:*	Rep Name (Printed):	Firm Address:	Telephone #:	Fax #:
Cleveland Brothers Equip.	Josh Hinkle	6286 W. Veteran Mem. Hwy. Bridgeport, W. Va 26338	304 644-2060	304-842-6806

**One Vendor Per Representative - No one individual is permitted to represent more than one vendor at the pre-bid meeting. If an individual attempts to represent two or more vendors, they will be required to select one vendor to which their attendance will be attributed. If no selection is made, the individual's attendance will be deemed to have not attended the pre-bid meeting unless another individual attended on their behalf.*



Tom Schanz
 Manager, Municipal Sales

318 Cooper Circle
 Peachtree City, GA 30269
 Direct: 470-278-2404
 Cell: 404-230-3728
 tschanz@sanyamerica.com
 www.sanyamerica.com



Matt Conner
 Sales Representative
 Construction

Boyd Company
 3 Park Drive
 Hub Industrial Park
 Nitro, WV 25143
 304.759.6400

304.543.5406 mobile

MatthewConner@boydcat.com
 www.boydcat.com



OFFICE (304) 346-5301
 (800) 640-8245

**WEST VIRGINIA
 TRACTOR COMPANY**
 CONSTRUCTION, MINING, MUNICIPAL & INDUSTRIAL EQUIPMENT

www.wvtractor.com

GARY W. GRADY
 PRESIDENT
 Cell (304) 549-6088

P. O. BOX 473
 214 VIRGINIA ST. W.
 CHAS., WV 25322/25302

wvtractor@msn.com



"Run with the Best"

Bo Kesler

Corporate

2098 Lillian Lane
 Pleasant Valley, WV 26554
 keslerbo@lecl.com
 www.lecl.com



JOHN DEERE

Office: 304-534-5454
 Fax: 304-534-5888
 Cell: 304-642-9991

**APPALACHIAN
 EQUIPMENT
 SOLUTIONS**

www.aesolutionswv.com

Justin Phillips

**Cleveland
 Brothers**



Joshua J. Hinkle
 Account Manager

Cleveland Brothers Equipment Co., Inc.

Route 76 East
 Bridgeport, WV 26330
 304-842-2222 tel
 304-842-6806 fax
 jhinkle@clevelandbrothers.com
 www.clevelandbrothers.com

mobile: 304-641-2060
 home: 304-269-5232

Pete Rufo
 Regional Sales Manager

HENKE
 AN ALAMO GROUP COMPANY

913.297.7830 Office
 913.680.9467 Mobile
 prufu@henkemfg.com

www.henkemfg.com

ADDENDUM ACKNOWLEDGEMENT FORM
SOLICITATION NO.: CRFQ DOT2100000108

Instructions: Please acknowledge receipt of all addenda issued with this solicitation by completing this addendum acknowledgment form. Check the box next to each addendum received and sign below. Failure to acknowledge addenda may result in bid disqualification.

Acknowledgment: I hereby acknowledge receipt of the following addenda and have made the necessary revisions to my proposal, plans and/or specification, etc.

Addendum Numbers Received:

(Check the box next to each addendum received)

- | | |
|----------------------------------------------------|------------------------------------------|
| <input checked="" type="checkbox"/> Addendum No. 1 | <input type="checkbox"/> Addendum No. 6 |
| <input type="checkbox"/> Addendum No. 2 | <input type="checkbox"/> Addendum No. 7 |
| <input type="checkbox"/> Addendum No. 3 | <input type="checkbox"/> Addendum No. 8 |
| <input type="checkbox"/> Addendum No. 4 | <input type="checkbox"/> Addendum No. 9 |
| <input type="checkbox"/> Addendum No. 5 | <input type="checkbox"/> Addendum No. 10 |

I understand that failure to confirm the receipt of addenda may be cause for rejection of this bid. I further understand that that any verbal representation made or assumed to be made during any oral discussion held between Vendor's representatives and any state personnel is not binding. Only the information issued in writing and added to the specifications by an official addendum is binding.

Company

Authorized Signature

Date

NOTE: This addendum acknowledgment should be submitted with the bid to expedite document processing.



Department of Administration
 Purchasing Division
 2019 Washington Street East
 Post Office Box 50130
 Charleston, WV 25305-0130

State of West Virginia
 Centralized Request for Quote
 Equipment

Proc Folder: 846036		Reason for Modification:	
Doc Description: ADDENDUM NO_2 Motor grader all wheel dr.		ADDENDUM NO_2 To move bid opening Bid Opening moves to 04/14/21	
Proc Type: Central Master Agreement			
Date Issued	Solicitation Closes	Solicitation No	Version
2021-04-01	2021-04-14 13:30	CRFQ 0803 DOT2100000108	3

BID RECEIVING LOCATION

BID CLERK
 DEPARTMENT OF ADMINISTRATION
 PURCHASING DIVISION
 2019 WASHINGTON ST E
 CHARLESTON WV 25305
 US

VENDOR

Vendor Customer Code: VS0000037852

Vendor Name : SANY America Inc

Address : 318 Cooper Circle

Street :

City : Peachtree City

State : GA **Country :** USA **Zip :** 30269

Principal Contact : Tom Schanz

Vendor Contact Phone: 404-230-3728 **Extension:**

FOR INFORMATION CONTACT THE BUYER

John W Estep
 304-558-2566
 john.w.estep@wv.gov

Vendor Signature X  **FEIN#** 20-5048542 **DATE** 4/14/21

All offers subject to all terms and conditions contained in this solicitation

ADDITIONAL INFORMATION

ADDENDUM NO_2

Addendum No_2 issued to publish and distribute the attached information to the vendor Community

REQUEST FOR QUOTATION:

The West Virginia Purchasing Division is soliciting bids on behalf of West Virginia Division of Highways to establish an open-end contract for a Motor Grader Articulated All Wheel Drive w/ Reversible Front Mounted Trip/Plow John Deere 672 AWD or equal. Per the bid requirements, specifications, terms and conditions attached to this solicitation.

INVOICE TO	SHIP TO
DIVISION OF HIGHWAYS EQUIPMENT DIVISION RT 33 83 BRUSHY ROAD CROSSING, PO BOX 610 BUCKHANNON WV 26201 US	DIVISION OF HIGHWAYS EQUIPMENT DIVISION 83 BRUSHY FORK RD CROSSING BUCKHANNON WV 26201 US

Line	Comm Ln Desc	Qty	Unit Issue	Unit Price	Total Price
1	Motor grader articulated all wheel drive	10.00000	EA		

Comm Code	Manufacturer	Specification	Model #
22101502			

Extended Description:

Motor grader articulated all wheel drive w/reversible front mounted trip/plow

SCHEDULE OF EVENTS

<u>Line</u>	<u>Event</u>	<u>Event Date</u>
1	Pre-Bid Meeting at 12:00pm @ Buckhannon	2021-03-24
2	Tech Questions due by 10:00am	2021-04-01

SOLICITATION NUMBER: CRFQ DOT2100000108

Addendum Number: 2

The purpose of this addendum is to modify the solicitation identified as CRFQ DOT2100000108 (“Solicitation”) to reflect the change(s) identified and described below.

Applicable Addendum Category:

- [X] Modify bid opening date and time
- [] Modify specifications of product or service being sought
- [] Attachment of vendor questions and responses
- [] Attachment of pre-bid sign-in sheet
- [] Correction of error
- [] Other

Additional Documentation:

1. To Move Bid Opening to 04/14/21 at 1:30 pm

Terms and Conditions:

1. All provisions of the Solicitation and other addenda not modified herein shall remain in full force and effect.
2. Vendor should acknowledge receipt of all addenda issued for this Solicitation by completing an Addendum Acknowledgment, a copy of which is included herewith. Failure to acknowledge addenda may result in bid disqualification. The addendum acknowledgement should be submitted with the bid to expedite document processing.

ADDENDUM ACKNOWLEDGEMENT FORM
SOLICITATION NO.: CRFQ DOT2100000108

Instructions: Please acknowledge receipt of all addenda issued with this solicitation by completing this addendum acknowledgment form. Check the box next to each addendum received and sign below. Failure to acknowledge addenda may result in bid disqualification.

Acknowledgment: I hereby acknowledge receipt of the following addenda and have made the necessary revisions to my proposal, plans and/or specification, etc.

Addendum Numbers Received:

(Check the box next to each addendum received)

- | | |
|----------------------------------------------------|------------------------------------------|
| <input type="checkbox"/> Addendum No. 1 | <input type="checkbox"/> Addendum No. 6 |
| <input checked="" type="checkbox"/> Addendum No. 2 | <input type="checkbox"/> Addendum No. 7 |
| <input type="checkbox"/> Addendum No. 3 | <input type="checkbox"/> Addendum No. 8 |
| <input type="checkbox"/> Addendum No. 4 | <input type="checkbox"/> Addendum No. 9 |
| <input type="checkbox"/> Addendum No. 5 | <input type="checkbox"/> Addendum No. 10 |

I understand that failure to confirm the receipt of addenda may be cause for rejection of this bid. I further understand that that any verbal representation made or assumed to be made during any oral discussion held between Vendor's representatives and any state personnel is not binding. Only the information issued in writing and added to the specifications by an official addendum is binding.

Company

Authorized Signature

Date

NOTE: This addendum acknowledgement should be submitted with the bid to expedite document processing.



Department of Administration
 Purchasing Division
 2019 Washington Street East
 Post Office Box 50130
 Charleston, WV 25305-0130

**State of West Virginia
 Centralized Request for Quote
 Equipment**

Proc Folder: 846036		Reason for Modification: ADDENDUM NO_3	
Doc Description: ADDENDUM NO_3 Motor grader all wheel dr.		Addendum No_3 - to attach Vendor Questions and Responses	
Proc Type: Central Master Agreement			
Date Issued	Solicitation Closes	Solicitation No	Version
2021-04-06	2021-04-14 13:30	CRFQ 0803 DOT2100000108	4

BID RECEIVING LOCATION

BID CLERK
 DEPARTMENT OF ADMINISTRATION
 PURCHASING DIVISION
 2019 WASHINGTON ST E
 CHARLESTON WV 25305
 US

VENDOR

Vendor Customer Code: VS000003 7852
Vendor Name : SANY America Inc
Address : 318 Cooper Circle
Street :
City : Peachtree City
State : GA **Country :** USA **Zip** 30269
Principal Contact : Tom Schanz
Vendor Contact Phone: 404-230-3 728 **Extension:**

FOR INFORMATION CONTACT THE BUYER
 John W Estep
 304-558-2566
 john.w.estep@wv.gov

Vendor Signature X  **FEIN#** 20-5048542 **DATE** 4/14/21

All offers subject to all terms and conditions contained in this solicitation

ADDITIONAL INFORMATION

ADDENDUM NO_3

Addendum No_3 issued to publish and distribute the attached information to the vendor Community

REQUEST FOR QUOTATION:

The West Virginia Purchasing Division is soliciting bids on behalf of West Virginia Division of Highways to establish an open-end contract for a Motor Grader Articulated All Wheel Drive w/ Reversible Front Mounted Trip/Plow John Deere 672 AWD or equal. Per the bid requirements, specifications, terms and conditions attached to this solicitation.

INVOICE TO	SHIP TO
DIVISION OF HIGHWAYS EQUIPMENT DIVISION RT 33 83 BRUSHY ROAD CROSSING, PO BOX 610 BUCKHANNON WV 26201 US	DIVISION OF HIGHWAYS EQUIPMENT DIVISION 83 BRUSHY FORK RD CROSSING BUCKHANNON WV 26201 US

Line	Comm Ln Desc	Qty	Unit Issue	Unit Price	Total Price
1	Motor grader articulated all wheel drive	10.00000	EA		

Comm Code	Manufacturer	Specification	Model #
22101502			

Extended Description:

Motor grader articulated all wheel drive w/reversible front mounted trip/plow

SCHEDULE OF EVENTS

Line	Event	Event Date
1	Pre-Bid Meeting at 12:00pm @ Buckhannon	2021-03-24
2	Tech Questions due by 10:00am	2021-04-01

State of West Virginia
Purchasing Division

Jeffery M. Pifer



PURCHASE REQUISITION

Requisition No. 7021E009/ CRFQ 0803 DOT2100000108	Buyer	Requisition Date 4/5/2021
Agency/Invoice To: WV Division of Highways Equipment Division PO Box 610 Buckhannon, WV 26201	TEAM Code _____	WVFIMS Document # 9017 2021 0803 276 076
Agency/Ship To: Jeffery M. Pifer P.E. Director WV Division of Highways 83 Brushy Fork Rd. Crossing Buckhannon, WV 26201	TEAM Code _____	Suggested Vendors: 1. 2. 3. <i>Additional Vendors on Reverse Side</i>
This Section Only For: Releases, Direct Purchases, Emergency Purchases & Agreements Vendor Name & Address:		PURCHASING DIVISION'S USE ONLY Commodity Code: _____ Instructions: _____
WVFIMS Vendor #	TEAM Vendor #	
Terms	F.O.B.	

Item No.	Quantity	Description	Unit Price	Amount
		Addendum <i>Type of Purchase</i> Technical questions and answers for CRFQ 0803 DOT2100000108.		
0070/EXP001/023/076				

Authorized Signature _____
 Title _____ Deputy Commissioner
 Telephone _____ 304-558-0444

Total Estimated Value of this Requisition: _____
 Maximum Budgeted Amount: _____

SOLICITATION NUMBER: CRFQ DOT2100000108

Addendum Number: 3

The purpose of this addendum is to modify the solicitation identified as CRFQ DOT2100000108 (“Solicitation”) to reflect the change(s) identified and described below.

Applicable Addendum Category:

- Modify bid opening date and time
- Modify specifications of product or service being sought
- Attachment of vendor questions and responses
- Attachment of pre-bid sign-in sheet
- Correction of error
- Other

Additional Documentation:

1. Vendor Questions and responses

Bid Opening remains 04/14/21 at 1:30pm

Terms and Conditions:

1. All provisions of the Solicitation and other addenda not modified herein shall remain in full force and effect.
2. Vendor should acknowledge receipt of all addenda issued for this Solicitation by completing an Addendum Acknowledgment, a copy of which is included herewith. Failure to acknowledge addenda may result in bid disqualification. The addendum acknowledgement should be submitted with the bid to expedite document processing.

ADDENDUM FOR PRE-BID

CRFQ 0803 DOT2100000108

MOTOR GRADER ARTICULATED AWD

The original language in contract will be listed first with question and answer to follow below.

1. 3.1.2.6 The size grader covered by this specification shall have a basic operating weight of not less than 40,000 lbs. minimum.

Question: Does the 40,000 lb. operating weight include all equipment required in the specifications?

Answer: The 40,000 lb operating weight does not include the weight of the front mounted blade.

2. 3.1.3 Engine

Question: Does the engine need to be manufactured by the motor grader manufacturer, or can an engine like Cummins power the grader?

Answer: The engine must be manufactured by the grader manufacturer.

3. 3.1.9.5 Unit bid shall produce a minimum of 250 NET HP in both the 7th and 8th forward gear.

Question: Will you accept 245 HP in 8th gear?

Answer: Yes. Will accept.

4. 3.1.10.1 Lowest gear speed – forward (maximum) 2.5 MPH

Question : We would like to request that this be raised to a maximum of 2.6 MPH?

Answer: Will accept 2.6 MPH

5. 3.1.10.4 Highest gear speed – reverse (minimum) 27.5 MPH

Question: We would like to request that this be changed to 23.2 MPH? A speed of 27.5 MPH in reverse is not necessary in a motor grader.

Answer: Will accept 23.2 MPH.

6. 3.1.13.2 Shall have dual 100 amp alternators.

Question: We would like to request that this be changed to a single 115 amp alternator- or we can provide a single 150 amp alternator.

Answer: Will accept a single 150 amp alternator or dual 100 amp only.

7. 3.1.13.5 Unit shall be equipped with a 24-to-12 volt converter to provide additional 12 volt, 25 amp continuous power sources for CB radios.

Question: We would like to request that it be revised to accept a 10 amp continuous power source- this is CAT standard and handles the task well.

Answer: No. Leave as written.

8. 3.1.18.1 Controls for steering and operating the grader, including the leaning of the front wheels, shall be of the full hydraulic type.

Question: We would like further clarification on what full hydraulic type means. Our machine is a full hydraulic machine, however it utilizes mechanical levers to actuate the hydraulic controls from the cab.

Answer: Movements such as steering or leaning of the wheels shall be accomplished by hydraulic cylinders.

9. 3.2.3.2 These cylinders shall be capable of reversing the plow from 35° right and 35° left minimum

Question # 1: Our snowplow is capable of reversing the plow from 30 degrees right and 30 degrees left. Could this be reduced?

Question # 2: Would you accept the plow at a 30 degree reversing capability as opposed to the 35 degree specified?

Answer: Will accept 30 degree left and right.

10. 3.2.8.1 Must have front mounted, Stainless Steel quick coupler, coupling system.

Question: We would like to request that the Stainless steel requirement be removed.

Answer: Leave as written.

11. 3.3.1.5 Inspection: WVDOH requires unit shall have a West Virginia State inspection sticker upon delivery.

The WVDOH will remove this line.

ADDENDUM ACKNOWLEDGEMENT FORM
SOLICITATION NO.: CRFO DOT2100000108

Instructions: Please acknowledge receipt of all addenda issued with this solicitation by completing this addendum acknowledgment form. Check the box next to each addendum received and sign below. Failure to acknowledge addenda may result in bid disqualification.

Acknowledgment: I hereby acknowledge receipt of the following addenda and have made the necessary revisions to my proposal, plans and/or specification, etc.

Addendum Numbers Received:

(Check the box next to each addendum received)

- | | |
|----------------------------------------------------|------------------------------------------|
| <input type="checkbox"/> Addendum No. 1 | <input type="checkbox"/> Addendum No. 6 |
| <input type="checkbox"/> Addendum No. 2 | <input type="checkbox"/> Addendum No. 7 |
| <input checked="" type="checkbox"/> Addendum No. 3 | <input type="checkbox"/> Addendum No. 8 |
| <input type="checkbox"/> Addendum No. 4 | <input type="checkbox"/> Addendum No. 9 |
| <input type="checkbox"/> Addendum No. 5 | <input type="checkbox"/> Addendum No. 10 |

I understand that failure to confirm the receipt of addenda may be cause for rejection of this bid. I further understand that that any verbal representation made or assumed to be made during any oral discussion held between Vendor's representatives and any state personnel is not binding. Only the information issued in writing and added to the specifications by an official addendum is binding.

Company

Authorized Signature

Date

NOTE: This addendum acknowledgement should be submitted with the bid to expedite document processing.



Department of Administration
 Purchasing Division
 2019 Washington Street East
 Post Office Box 50130
 Charleston, WV 25305-0130

State of West Virginia
 Centralized Request for Quote
 Equipment

Proc Folder: 846036		Reason for Modification:	
Doc Description: ADDENDUM NO_4 Motor grader all wheel dr.		ADDENDUM NO_4 VENDOR QUESTIONS AND RESPONSES	
Proc Type: Central Master Agreement			
Date Issued	Solicitation Closes	Solicitation No	Version
2021-04-12	2021-04-14 13:30	CRFQ 0803 DOT2100000108	5

BID RECEIVING LOCATION

BID CLERK
 DEPARTMENT OF ADMINISTRATION
 PURCHASING DIVISION
 2019 WASHINGTON ST E
 CHARLESTON WV 25305
 US

VENDOR

Vendor Customer Code: VS0000037852

Vendor Name : SANY America Inc

Address : 318 Cooper Circle

Street :

City : Peachtree City

State : GA **Country :** USA **Zip :** 30269

Principal Contact : Tom Schanz

Vendor Contact Phone: 404-230-3728 **Extension:**

FOR INFORMATION CONTACT THE BUYER

John W Estep
 304-558-2566
 john.w.estep@wv.gov

Vendor Signature X  **FEIN#** 20-5048542 **DATE** 4/14/21

All offers subject to all terms and conditions contained in this solicitation

ADDITIONAL INFORMATION

ADDENDUM NO_4

Addendum No_4 issued to publish and distribute the attached information to the vendor Community

REQUEST FOR QUOTATION:

The West Virginia Purchasing Division is soliciting bids on behalf of West Virginia Division of Highways to establish an open-end contract for a Motor Grader Articulated All Wheel Drive w/ Reversible Front Mounted Trip/Plow John Deere 672 AWD or equal. Per the bid requirements, specifications, terms and conditions attached to this solicitation.

INVOICE TO

DIVISION OF HIGHWAYS
EQUIPMENT DIVISION RT 33
83 BRUSHY ROAD
CROSSING, PO BOX 610
BUCKHANNON WV
US

SHIP TO

DIVISION OF HIGHWAYS
EQUIPMENT DIVISION
83 BRUSHY FORK RD
CROSSING WV
BUCKHANNON WV
US

Line	Comm Ln Desc	Qty	Unit Issue	Unit Price	Total Price
1	Motor grader articulated all wheel drive	10.00000	EA		

Comm Code	Manufacturer	Specification	Model #
22101502			

Extended Description:

Motor grader articulated all wheel drive w/reversible front mounted trip/plow

SCHEDULE OF EVENTS

<u>Line</u>	<u>Event</u>	<u>Event Date</u>
1	Pre-Bid Meeting at 12:00pm @ Buckhannon	2021-03-24
2	Tech Questions due by 10:00am	2021-04-01

SOLICITATION NUMBER: CRFQ DOT2100000108

Addendum Number: 4

The purpose of this addendum is to modify the solicitation identified as CRFQ DOT2100000108 (“Solicitation”) to reflect the change(s) identified and described below.

Applicable Addendum Category:

- Modify bid opening date and time
- Modify specifications of product or service being sought
- Attachment of vendor questions and responses
- Attachment of pre-bid sign-in sheet
- Correction of error
- Other

Additional Documentation:

1. Vendor Questions and Responses

Bid Opening remains 04/14/21 at 1:30pm

Terms and Conditions:

1. All provisions of the Solicitation and other addenda not modified herein shall remain in full force and effect.
2. Vendor should acknowledge receipt of all addenda issued for this Solicitation by completing an Addendum Acknowledgment, a copy of which is included herewith. Failure to acknowledge addenda may result in bid disqualification. The addendum acknowledgement should be submitted with the bid to expedite document processing.

ADDENDUM FOR PRE-BID

CRFQ 0803 DOT2100000108

MOTOR GRADER ARTICULATED AWD

The original language in contract will be listed first with question and answer to follow below.

1. 3.2.8.1 Must have front mounted, Stainless Steel quick coupler, coupling system.

Question: We requested to have the Stainless steel requirement be removed, but it was left as originally written. Can you clarify what portion of the coupler they are requiring to be stainless steel? Is it the quick couplers or the hydraulic lines themselves?

Answer: The quick couplers themselves shall be stainless steel.

ADDENDUM ACKNOWLEDGEMENT FORM
SOLICITATION NO.: CRFQ DOT2100000108

Instructions: Please acknowledge receipt of all addenda issued with this solicitation by completing this addendum acknowledgment form. Check the box next to each addendum received and sign below. Failure to acknowledge addenda may result in bid disqualification.

Acknowledgment: I hereby acknowledge receipt of the following addenda and have made the necessary revisions to my proposal, plans and/or specification, etc.

Addendum Numbers Received:

(Check the box next to each addendum received)

- | | |
|----------------------------------------------------|------------------------------------------|
| <input type="checkbox"/> Addendum No. 1 | <input type="checkbox"/> Addendum No. 6 |
| <input type="checkbox"/> Addendum No. 2 | <input type="checkbox"/> Addendum No. 7 |
| <input type="checkbox"/> Addendum No. 3 | <input type="checkbox"/> Addendum No. 8 |
| <input checked="" type="checkbox"/> Addendum No. 4 | <input type="checkbox"/> Addendum No. 9 |
| <input type="checkbox"/> Addendum No. 5 | <input type="checkbox"/> Addendum No. 10 |

I understand that failure to confirm the receipt of addenda may be cause for rejection of this bid. I further understand that that any verbal representation made or assumed to be made during any oral discussion held between Vendor's representatives and any state personnel is not binding. Only the information issued in writing and added to the specifications by an official addendum is binding.

Company

Authorized Signature

Date

NOTE: This addendum acknowledgment should be submitted with the bid to expedite document processing.

Exhibit A

Motor Grader

Item No.	Description:	Make/Model & Year	Estimated Unit Quantity	Unit Price	Item Total Cost
1	One Complete unit: Motor Grader Articulated All Wheel Drive w/Reversible Front Mounted Trip/Plow	2021 SANY SMG200C-8	10	\$190,517.00	\$1,905,170.00
Total Bid Cost					\$1,905,170.00

Vendor Information

Company Name: SANY America, Inc.
Contract Manager: Tom Schanz - Manager, Municipal Sales
Address: 318 Cooper Circle N
Peachtree City, GA 30269
Phone: 404-230-3728
Fax:
Email: tschanz@sanyamerica.com
Signature: 



INSTRUCTIONS TO VENDORS SUBMITTING BIDS

1. REVIEW DOCUMENTS THOROUGHLY: The attached documents contain a solicitation for bids. Please read these instructions and all documents attached in their entirety. These instructions provide critical information about requirements that if overlooked could lead to disqualification of a Vendor's bid. All bids must be submitted in accordance with the provisions contained in these instructions and the Solicitation. Failure to do so may result in disqualification of Vendor's bid.

2. MANDATORY TERMS: The Solicitation may contain mandatory provisions identified by the use of the words "must," "will," and "shall." Failure to comply with a mandatory term in the Solicitation will result in bid disqualification.

3. PREBID MEETING: The item identified below shall apply to this Solicitation.

A pre-bid meeting will not be held prior to bid opening

A **MANDATORY PRE-BID** meeting will be held at the following place and time:

Equipment Division
83 Brushy Fork Rd. Crossing
Buckhannon, WV 26201
March 24, 2021 @ 12:00pm

All Vendors submitting a bid must attend the mandatory pre-bid meeting. Failure to attend the mandatory pre-bid meeting shall result in disqualification of the Vendor's bid. No one individual is permitted to represent more than one vendor at the pre-bid meeting. Any individual that does attempt to represent two or more vendors will be required to select one vendor to which the individual's attendance will be attributed. The vendors not selected will be deemed to have not attended the pre-bid meeting unless another individual attended on their behalf.

An attendance sheet provided at the pre-bid meeting shall serve as the official document verifying attendance. Any person attending the pre-bid meeting on behalf of a Vendor must list on the attendance sheet his or her name and the name of the Vendor he or she is representing.

Additionally, the person attending the pre-bid meeting should include the Vendor's E-Mail address, phone number, and Fax number on the attendance sheet. It is the Vendor's responsibility to locate the attendance sheet and provide the required information. Failure to complete the attendance sheet as required may result in disqualification of Vendor's bid.

All Vendors should arrive prior to the starting time for the pre-bid. Vendors who arrive after the starting time but prior to the end of the pre-bid will be permitted to sign in but are charged with knowing all matters discussed at the pre-bid.

Questions submitted at least five business days prior to a scheduled pre-bid will be discussed at the pre-bid meeting if possible. Any discussions or answers to questions at the pre-bid meeting
Revised 02/10/2021

are preliminary in nature and are non-binding. Official and binding answers to questions will be published in a written addendum to the Solicitation prior to bid opening.

4. VENDOR QUESTION DEADLINE: Vendors may submit questions relating to this Solicitation to the Purchasing Division. Questions must be submitted in writing. All questions must be submitted on or before the date listed below and to the address listed below in order to be considered. A written response will be published in a Solicitation addendum if a response is possible and appropriate. Non-written discussions, conversations, or questions and answers regarding this Solicitation are preliminary in nature and are nonbinding.

Submitted e-mails should have solicitation number in the subject line.

Question Submission Deadline: April 1, 2021 by 10:00am

Submit Questions to: John Estep
2019 Washington Street, East
Charleston, WV 25305
Fax: (304) 558-4115 (Vendors should not use this fax number for bid submission)
Email: john.w.estep@wv.gov

5. VERBAL COMMUNICATION: Any verbal communication between the Vendor and any State personnel is not binding, including verbal communication at the mandatory pre-bid conference. Only information issued in writing and added to the Solicitation by an official written addendum by the Purchasing Division is binding.

6. BID SUBMISSION: All bids must be submitted electronically through wvOASIS or signed and delivered by the Vendor to the Purchasing Division at the address listed below on or before the date and time of the bid opening. Any bid received by the Purchasing Division staff is considered to be in the possession of the Purchasing Division and will not be returned for any reason. The Purchasing Division will not accept bids, modification of bids, or addendum acknowledgment forms via e-mail. Acceptable delivery methods include electronic submission via wvOASIS, hand delivery, delivery by courier, or facsimile.

The bid delivery address is:
Department of Administration, Purchasing Division
2019 Washington Street East
Charleston, WV 25305-0130

A bid that is not submitted electronically through wvOASIS should contain the information listed below on the face of the envelope or the bid may be rejected by the Purchasing Division.:

SEALED BID:	Motor Grader AWD
BUYER:	John Estep
SOLICITATION NO.:	CRFQ 0803 DOT2100000108
BID OPENING DATE:	April 8, 2021
BID OPENING TIME:	1:30 PM
FAX NUMBER:	304-558-3970

Revised 02/10/2021

The Purchasing Division may prohibit the submission of bids electronically through wvOASIS at its sole discretion. Such a prohibition will be contained and communicated in the wvOASIS system resulting in the Vendor's inability to submit bids through wvOASIS. Submission of a response to a Request for Proposal is not permitted in wvOASIS.

For Request For Proposal ("RFP") Responses Only: In the event that Vendor is responding to a request for proposal, the Vendor shall submit one original technical and one original cost proposal plus _____ convenience copies of each to the Purchasing Division at the address shown above. Additionally, the Vendor should identify the bid type as either a technical or cost proposal on the face of each bid envelope submitted in response to a request for proposal as follows:

BID TYPE: (This only applies to CRFP)

- Technical
- Cost

7. BID OPENING: Bids submitted in response to this Solicitation will be opened at the location identified below on the date and time listed below. Delivery of a bid after the bid opening date and time will result in bid disqualification. For purposes of this Solicitation, a bid is considered delivered when confirmation of delivery is provided by wvOASIS (in the case of electronic submission) or when the bid is time stamped by the official Purchasing Division time clock (in the case of hand delivery).

Bid Opening Date and Time: **APRIL 8, 2021 @ 1:30pm**

Bid Opening Location: Department of Administration, Purchasing Division
2019 Washington Street East
Charleston, WV 25305-0130

8. ADDENDUM ACKNOWLEDGEMENT: Changes or revisions to this Solicitation will be made by an official written addendum issued by the Purchasing Division. Vendor should acknowledge receipt of all addenda issued with this Solicitation by completing an Addendum Acknowledgment Form, a copy of which is included herewith. Failure to acknowledge addenda may result in bid disqualification. The addendum acknowledgement should be submitted with the bid to expedite document processing.

9. BID FORMATTING: Vendor should type or electronically enter the information onto its bid to prevent errors in the evaluation. Failure to type or electronically enter the information may result in bid disqualification.

10. ALTERNATE MODEL OR BRAND: Unless the box below is checked, any model, brand, or specification listed in this Solicitation establishes the acceptable level of quality only and is not intended to reflect a preference for, or in any way favor, a particular brand or vendor. Vendors may bid alternates to a listed model or brand provided that the alternate is at least equal to the model or brand and complies with the required specifications. The equality of any alternate being bid shall be determined by the State at its sole discretion. Any Vendor bidding an alternate model or brand should clearly identify the alternate items in its bid and should include manufacturer's specifications, industry literature, and/or any other relevant documentation demonstrating the

equality of the alternate items. Failure to provide information for alternate items may be grounds for rejection of a Vendor's bid.

This Solicitation is based upon a standardized commodity established under W. Va. Code § 5A-3-61. Vendors are expected to bid the standardized commodity identified. Failure to bid the standardized commodity will result in your firm's bid being rejected.

11. EXCEPTIONS AND CLARIFICATIONS: The Solicitation contains the specifications that shall form the basis of a contractual agreement. Vendor shall clearly mark any exceptions, clarifications, or other proposed modifications in its bid. Exceptions to, clarifications of, or modifications of a requirement or term and condition of the Solicitation may result in bid disqualification.

12. COMMUNICATION LIMITATIONS: In accordance with West Virginia Code of State Rules §148-1-6.6, communication with the State of West Virginia or any of its employees regarding this Solicitation during the solicitation, bid, evaluation or award periods, except through the Purchasing Division, is strictly prohibited without prior Purchasing Division approval. Purchasing Division approval for such communication is implied for all agency delegated and exempt purchases.

13. REGISTRATION: Prior to Contract award, the apparent successful Vendor must be properly registered with the West Virginia Purchasing Division and must have paid the \$125 fee, if applicable.

14. UNIT PRICE: Unit prices shall prevail in cases of a discrepancy in the Vendor's bid.

15. PREFERENCE: Vendor Preference may be requested in purchases of motor vehicles or construction and maintenance equipment and machinery used in highway and other infrastructure projects. Any request for preference must be submitted in writing with the bid, must specifically identify the preference requested with reference to the applicable subsection of West Virginia Code § 5A-3-37, and must include with the bid any information necessary to evaluate and confirm the applicability of the requested preference. A request form to help facilitate the request can be found at:

<http://www.state.wv.us/admin/purchase/vrc/Venpref.pdf>.

15A. RECIPROCAL PREFERENCE: The State of West Virginia applies a reciprocal preference to all solicitations for commodities and printing in accordance with W. Va. Code § 5A-3-37(b). In effect, non-resident vendors receiving a preference in their home states, will see that same preference granted to West Virginia resident vendors bidding against them in West Virginia. Any request for reciprocal preference must include with the bid any information necessary to evaluate and confirm the applicability of the preference. A request form to help facilitate the request can be found at: <http://www.state.wv.us/admin/purchase/vrc/Venpref.pdf>.

16. SMALL, WOMEN-OWNED, OR MINORITY-OWNED BUSINESSES: For any solicitations publicly advertised for bid, in accordance with West Virginia Code §5A-3-37(a)(7) and W. Va. CSR § 148-22-9, any non-resident vendor certified as a small, women-owned, or minority-owned business under W. Va. CSR § 148-22-9 shall be provided the same preference made available to any resident vendor. Any non-resident small, women-owned, or

minority-owned business must identify itself as such in writing, must submit that writing to the Purchasing Division with its bid, and must be properly certified under W. Va. CSR § 148-22-9 prior to contract award to receive the preferences made available to resident vendors. Preference for a non-resident small, women-owned, or minority owned business shall be applied in accordance with W. Va. CSR § 148-22-9.

17. WAIVER OF MINOR IRREGULARITIES: The Director reserves the right to waive minor irregularities in bids or specifications in accordance with West Virginia Code of State Rules § 148-1-4.6.

18. ELECTRONIC FILE ACCESS RESTRICTIONS: Vendor must ensure that its submission in wvOASIS can be accessed and viewed by the Purchasing Division staff immediately upon bid opening. The Purchasing Division will consider any file that cannot be immediately accessed and viewed at the time of the bid opening (such as, encrypted files, password protected files, or incompatible files) to be blank or incomplete as context requires, and are therefore unacceptable. A vendor will not be permitted to unencrypt files, remove password protections, or resubmit documents after bid opening to make a file viewable if those documents are required with the bid. A Vendor may be required to provide document passwords or remove access restrictions to allow the Purchasing Division to print or electronically save documents provided that those documents are viewable by the Purchasing Division prior to obtaining the password or removing the access restriction.

19. NON-RESPONSIBLE: The Purchasing Division Director reserves the right to reject the bid of any vendor as Non-Responsible in accordance with W. Va. Code of State Rules § 148-1-5.3, when the Director determines that the vendor submitting the bid does not have the capability to fully perform, or lacks the integrity and reliability to assure good-faith performance.”

20. ACCEPTANCE/REJECTION: The State may accept or reject any bid in whole, or in part in accordance with W. Va. Code of State Rules § 148-1-4.5. and § 148-1-6.4.b.”

21. YOUR SUBMISSION IS A PUBLIC DOCUMENT: Vendor’s entire response to the Solicitation and the resulting Contract are public documents. As public documents, they will be disclosed to the public following the bid/proposal opening or award of the contract, as required by the competitive bidding laws of West Virginia Code §§ 5A-3-1 et seq., 5-22-1 et seq., and 5G-1-1 et seq. and the Freedom of Information Act West Virginia Code §§ 29B-1-1 et seq.

DO NOT SUBMIT MATERIAL YOU CONSIDER TO BE CONFIDENTIAL, A TRADE SECRET, OR OTHERWISE NOT SUBJECT TO PUBLIC DISCLOSURE.

Submission of any bid, proposal, or other document to the Purchasing Division constitutes your explicit consent to the subsequent public disclosure of the bid, proposal, or document. The Purchasing Division will disclose any document labeled “confidential,” “proprietary,” “trade secret,” “private,” or labeled with any other claim against public disclosure of the documents, to include any “trade secrets” as defined by West Virginia Code § 47-22-1 et seq. All submissions are subject to public disclosure without notice.

22. INTERESTED PARTY DISCLOSURE: West Virginia Code § 6D-1-2 requires that the vendor submit to the Purchasing Division a disclosure of interested parties to the contract for all contracts with an actual or estimated value of at least \$1 Million. That disclosure must occur on the form prescribed and approved by the WV Ethics Commission prior to contract award. A copy of that form is included with this solicitation or can be obtained from the WV Ethics Commission. This requirement does not apply to publicly traded companies listed on a national or international stock exchange. A more detailed definition of interested parties can be obtained from the form referenced above.

23. WITH THE BID REQUIREMENTS: In instances where these specifications require documentation or other information with the bid, and a vendor fails to provide it with the bid, the Director of the Purchasing Division reserves the right to request those items after bid opening and prior to contract award pursuant to the authority to waive minor irregularities in bids or specifications under W. Va. CSR § 148-1-4.6. This authority does not apply to instances where state law mandates receipt with the bid.

WWREQUEST FOR QUOTATION
(Class 405) Motor Grader Articulated All Wheel Drive w/ Reversible Front Mounted
Trip/Plow John Deere 672 AWD or Equal

SPECIFICATIONS

1. **PURPOSE AND SCOPE:** The West Virginia Purchasing Division is soliciting bids on behalf of West Virginia Division of Highways to establish an open-end contract for a Motor Grader Articulated All Wheel Drive w/ Reversible Front Mounted Trip/Plow John Deere 672 AWD or equal.

2. **DEFINITIONS:** The terms listed below shall have the meanings assigned to them below. Additional definitions can be found in section 2 of the General Terms and Conditions.
 - 2.1 **“Contract Item” or “Contract Items”** means the list of items identified in Section 3.1 below and on the Pricing Pages.
 - 2.2 **“Pricing Pages”** means the schedule of prices, estimated order quantity, and totals contained in wvOASIS or attached hereto as Exhibit A and used to evaluate the Solicitation responses.
 - 2.3 **“Solicitation”** means the official notice of an opportunity to supply the State with goods or services that is published by the Purchasing Division.
 - 2.4 **“WVDOH”** means West Virginia Division of Highways.
 - 2.5 **“CCA”** means cold cranking amps.
 - 2.6 **“SAE”** means Society of Automotive Engineers.
 - 2.7 **“MPH”** means miles per hour.
 - 2.8 **“°”** means degrees.
 - 2.9 **“HP”** means horsepower.
 - 2.10 **“F”** means Fahrenheit.
 - 2.11 **“R.O.P.S”** means rollover protection system.
 - 2.10 **“AWD”** means All Wheel Drive.
 - 2.11 **“Class 405”**Internal use for WVDOH.
 - 2.12 **“LED”** means light-emitting diode.

WWREQUEST FOR QUOTATION
(Class 405) Motor Grader Articulated All Wheel Drive w/ Reversible Front Mounted
Trip/Plow John Deere 672 AWD or Equal

3. GENERAL REQUIREMENTS:

3.1 Contract Items and Mandatory Requirements: Vendor shall provide Agency with the Contract Items listed below on an open-end and continuing basis. Contract Items must meet or exceed the mandatory requirements as shown below.

3.1.1 Motor Grader mandatory requirements.

3.1.1.1 The unit specified herein and offered shall be manufactured on or after January 1, 2021 and will be clearly identified and marked with date of manufacture.

3.1.1.2 All daily service shall be done from ground level.

3.1.1.3 Motor Grader shall be of conventional design and heavy-duty construction. Units shall be delivered complete with all the manufacturers currently advertised standard features unless specifically addressed herein.

3.1.2 Operational Use:

3.1.2.1 The grader shall perform the following types of work under full control, completely free of conditions requiring undue operator effort.

- A. General maintenance and improvements to existing roads
- B. Coarse and fine grading and spreading
- C. High and low bank sloping
- D. Clearing slides
- E. Scarifying
- F. Ditching, including reconditioning old ditches and cutting new ditches, which at times will include deep ditching.
- G. Wind Rowing
- H. Snow and Ice removal

3.1.2.2 The grader shall be capable of carrying out any of the above operations under all types of conditions ranging from light soils to rocky materials.

WWREQUEST FOR QUOTATION
(Class 405) Motor Grader Articulated All Wheel Drive w/ Reversible Front Mounted
Trip/Plow John Deere 672 AWD or Equal

3.1.2.3 The grader shall be capable of operating on mountain roads of low construction standards having sustained grades in excess of 7% minimum and steep pitches up to 18% maximum.

3.1.2.4 The minimum blade Hp shall be 33,900 lbs. force with use of all wheel drive unit at a traction coefficient of 0.9.

3.1.2.5 The basic operating weight shall exclude: (A) Front Mounted Scarifier (B) Hydro-inflation and (C) Wheel or tire ballast.

3.1.2.6 The size grader covered by this specification shall have a basic operating weight of not less than 40,000 lbs. minimum.

3.1.2.7 Shall have minimum wheelbase of 232 inches. (Distance from the center of front axle to the center line of the rear main tandem drive axles).

3.1.3 Engine: Shall be designed and built by the manufacturer.

3.1.3.1 Shall be Tier 4 Final Compliant, 6-cylinder diesel engine.

3.1.3.2 Engine displacement shall not be less than 9.0L minimum.

3.1.3.3 Engine shall be equipped with an adequate and efficient lubrication system and fuel injection mechanism.

3.1.3.4 Engine shall have manufacturers' heavy-duty fuel filtering system with fuel heater contained in filter base.

3.1.3.5 Engine shall have manufacturers full flow type lubricating oil filter.

3.1.3.6 The air cleaner shall be the dual element type (primary and safety dry type element) with a built-in pre-cleaner section and automatic dust ejection.

3.1.3.7 Air cleaner hose shall be the metal or heavy duty flexible non-collapsible type, with metal or molded rubber elbows. (Wire reinforced hose is not acceptable).

3.1.3.8 All air cleaner connections shall be banded.

WWREQUEST FOR QUOTATION
(Class 405) Motor Grader Articulated All Wheel Drive w/ Reversible Front Mounted
Trip/Plow John Deere 672 AWD or Equal

3.1.3.9 Filter shall be located inside of hood or at location protected from contaminants thrown by tandem wheels.

3.1.4 Engine Governor

3.1.4.1 Engine shall be equipped with a variable speed governor of the mechanical or hydraulic type and shall be driven from the engine.

3.1.4.2 Provisions shall be made for permitting regulation of the governed speed-setting throughout the engine load range while the engine is in operation.

3.1.5 Cooling System

3.1.5.1 The engine cooling system shall be maximum available from the manufacturer and have an operating ambient temperature range of minimum -34° F. to +125°F. maximum.

3.1.5.2 Coolants system shall be filled with extended life permanent type anti-freeze with freeze protection to -34°F. minimum.

3.1.5.3 Cooling system shall include manufacturers heavy duty radiator protected by a guard, a rearward exhaust fan, a circulating water pump and a thermostat and by pass for warm up. Engine fan shall automatically adjust fan speed by a variable hydraulic fan pump to meet engine cooling requirements.

3.1.6 Engine Housing

3.1.6.1 The engine shall be protected with a metal hood and manufacturers lockable side panels (keyed alike).

3.1.7 Engine Starting System

3.1.7.1 The grader shall be provided with manufacturers heavy duty starting system and shall have keyed ignition system or push-button.

3.1.7.2 Starting system shall be capable of cranking the engine in ambient temperature of -30°F minimum.

**WWREQUEST FOR QUOTATION
(Class 405) Motor Grader Articulated All Wheel Drive w/ Reversible Front Mounted
Trip/Plow John Deere 672 AWD or Equal**

3.1.7.3 A concealed electrical disconnect switch to prevent unauthorized starting of the grader shall be provided.

3.1.8 Fuel Tank (s)

3.1.8.1 Manufacturers standard fuel tank(s) (minimum 90 gallon capacity) is (are) acceptable and shall be located so as not to be affected by heat from engine, exhaust piping, or muffler.

3.1.9 Power Shift Transmission: Transmission shall be designed and built by the machine manufacturer.

3.1.9.1 The transmission shall be direct drive, power shift, counter-shaft type. Transmission guard shall be included.

3.1.9.2 Transmission direction and gear shifting shall be electronically and proportionally controlled from forward to reverse and from gear to gear.

3.1.9.3 Transmission shall have no less than eight(8) forward speeds and six(6) reverse speeds.

3.1.9.4 Electronic throttle control shall be available.

3.1.9.5 Unit bid shall produce a minimum of 250 NET HP in both the 7th and 8th forward gear

3.1.10 Travel Speeds

3.1.10.1 Lowest gear speed – forward (maximum) 2.5 MPH

3.1.10.2 Highest gear speed – forward (minimum) 27.5 MPH

3.1.10.3 Lowest gear speed – reverse (maximum) 2.5 MPH

3.1.10.4 Highest gear speed – reverse (minimum) 27.5 MPH

WWREQUEST FOR QUOTATION
(Class 405) Motor Grader Articulated All Wheel Drive w/ Reversible Front Mounted
Trip/Plow John Deere 672 AWD or Equal

3.1.11 Final Drive

3.1.11.1 All shafts, gears, sprockets, chains, bearings, etc. shall be of sufficient strength and capacity to safely transmit full power of the engine to the driving wheels without component failure.

3.1.11.2 All gears and sprocket shall be machine cut.

3.1.11.3 Drive gears shall run in oil bath.

3.1.11.4 All driving mechanisms shall be fully enclosed and protected against lubricant leakage, dust, dirt, water, etc.

3.1.11.5 Tandem frames shall be mounted on and pivot about the axle so the equal weight is carried on all four (4) wheels when operating over rough terrain without effecting the evenness of the blade cut.

3.1.11.6 Tandem oscillation shall not be less than 15° upward from the horizontal and not less than 15° down.

3.1.11.7 A stop shall be permanently attached to the grader to limit or prevent tandem oscillation (or in lieu of a stop) lifting attachment may be located at the center of the tandem to prevent tandem case oscillation or damage during loading or shipment.

3.1.11.8 The differential lock/unlock shall be operator controlled.

3.1.11.9 The differential lock/unlock shall be electro-hydraulically controlled with no speed restrictions for engaging/disengaging.

3.1.11.10 Left and Right tandem case shall be covered with anti-slip walk platform for standing and walking.

3.1.12 Front Axle

3.1.12.1 The front axle shall be an arched design for maximum clearance.

3.1.12.2 Axle shall be fitted with leaning type wheels and operating mechanism.

WWREQUEST FOR QUOTATION
(Class 405) Motor Grader Articulated All Wheel Drive w/ Reversible Front Mounted
Trip/Plow John Deere 672 AWD or Equal

3.1.12.3 Maximum front wheel lean shall be no less than 18° to the right and left of vertical.

3.1.12.4 Positive means shall be provided to prevent tires from rubbing when in the extreme leaning position.

3.1.12.5 Front wheel hubs shall not extend beyond the tire line.

3.1.12.6 Unit shall be equipped with the manufacturers' all-wheel drive system in order to improve tractive effort and steering control in slippery conditions.

3.1.12.7 The all-wheel drive system shall produce a maximum stall torque of no less than 14,500 lb. ft.

3.1.12.8 All-wheel drive system engage/disengage shall be accessible at operator's station and without any manual connect/disconnect procedure.

3.1.12.9 Front axle shall be steered by steering wheel; **Joystick steering will not be accepted.**

3.1.13 Electrical

3.1.13.1 The voltage rating of the electrical system shall be what is regularly provided by the manufacturer as standard equipment.

3.1.13.2 Shall have dual 100 amp alternators.

3.1.13.2 Wiring shall be enclosed in a harness formed of non-metallic loom and securely anchored to the frame in protected locations.

3.1.13.3 Any wiring in exposed locations that are subject to damage in normal use shall be enclosed in conduit.

3.1.13.4 All electrical wiring between the engine and alternator to other parts of the unit shall be connected by a plug type disconnect block with a prong and a receptacle configuration such that it will fit together only one way and located convenient to the engine.

**WWREQUEST FOR QUOTATION
(Class 405) Motor Grader Articulated All Wheel Drive w/ Reversible Front Mounted
Trip/Plow John Deere 672 AWD or Equal**

3.1.13.5 Unit shall be equipped with a 24-to-12volt converter to provide additional 12volt, 25amp continuous power sources for CB radios.

3.1.14 Lighting Equipment

3.1.14.1 Shall have two (2) LED headlights with high/low beam switch operated from the cab.

3.1.14.2 Headlights shall be mounted within the width of the cab.

3.1.14.3 Separate front (amber) and rear (red) turn signals shall be provided.

3.1.14.4 Lamps shall be mounted within the width of the cab on the front and rear or rear lamps may be mounted within the width of the radiator or engine housing.

3.1.14.5 All lamp sockets shall be brass or other corrosion resistant material.

3.1.14.6 Turn signals shall incorporate a heavy duty flasher.

3.1.14.7 Shall have operator controlled four-way hazardous warning signal with convenient cab located switch.

3.1.14.8 Two LED work light shall be provided on each side of the front lower section of the cab.

3.1.14.9 Work lights shall be swivel mounted to facilitate lighting of the blade working area, shall be switched and marked at cab location.

3.1.14.10 Shall be a minimum of two LED mid-frame lights to illuminate moldboard and surrounding areas.

3.1.14.11 Shall have four LED corner cab lights, two LED front cab lights and two LED right side cab work lights.

3.1.14.12 Sealed beam back up light shall be provided.

WWREQUEST FOR QUOTATION
(Class 405) Motor Grader Articulated All Wheel Drive w/ Reversible Front Mounted
Trip/Plow John Deere 672 AWD or Equal

3.1.14.13 Manufacturers stop-tail lights shall be recessed, and shock mounted.

3.1.14.14 Shall have manufacturers standard instrument lighting package.

3.1.14.15 Interior cab light shall be manufacturers standard for proposed model.

3.1.14.16 All lights shall be controlled by manufacturers heavy duty switches mounted at instrumental panel.

3.1.14.17 Lighting circuits shall be wired so that if a short occurs engine shutdown will not occur.

3.1.14.18 All circuits shall be protected by re-set circuit breakers or fuses.

3.1.15 Batteries

3.1.15.1 Batteries shall be maintenance free heavy duty with minimum of 1125 CCA.

3.1.15.2 Manufacturers battery (ies) hold down device shall be provided.

3.1.15.3 Battery(ies) shall be easily accessible for servicing and be delivered with electrolyte installed.

3.1.16 Wheels/Tires

3.1.16.1 Graders shall be provided with six (6) wheels, two (2) wheels on the front axle and four (4) wheels arranged in tandem on the rear axle with manufacturers drive available at all six (6) wheels.

3.1.16.2 Both front and rear shall be tubeless type radial and 14.00 x 24, with correct ply rating for machine with snow plow blade attached.

3.1.16.3 Tires shall be mounted on 10 inch wide rims.

WWREQUEST FOR QUOTATION
(Class 405) Motor Grader Articulated All Wheel Drive w/ Reversible Front Mounted
Trip/Plow John Deere 672 AWD or Equal

3.1.17 Braking System

3.1.17.1 The service brakes shall be multi-disc, oil cooled and completely sealed.

3.1.17.2 Service brakes shall be hydraulically actuated, utilizing dual independent brake circuits.

3.1.17.3 Shall have wet disc type inboard on all wheels.

3.1.17.4 Parking brake shall be multi- disc, oil cooled, spring applied, hydraulically released, sealed, adjustment free and integrated into the transmission.

3.1.17.5 The service brake system shall incorporate a stored energy source, and accumulator, or other means to effectively allow full operator application of the brake system in the event any of the following fail; the engine, hydraulic, or air pump.

3.1.18 Controls

3.1.18.1 Controls for steering and operating the grader, including the leaning of the front wheels, shall be of the full hydraulic type.

3.1.18.2 Controls shall permit simultaneous operation of at least three (3) functional components without appreciable loss of component speed or power.

3.1.18.3 Links, cams, gears, etc. in the control mechanisms shall withstand the maximum stresses imposed upon them under normal operating conditions.

3.1.18.4 Hydraulic system shall be protected against the entrance of contamination and complete with the manufacturers recommended operating accessories and shall include an efficient filtering system easily accessible for cleaning and replacement.

3.1.18.5 The hydraulic control system shall be equipped with a pressure relief valve and an overload relief which will automatically reset when overload is cleared or pressure-compensated system.

**WWREQUEST FOR QUOTATION
(Class 405) Motor Grader Articulated All Wheel Drive w/ Reversible Front Mounted
Trip/Plow John Deere 672 AWD or Equal**

3.1.18.6 The hydraulic system shall be capable of providing a moldboard lift speed of 3 inches minimum per second.

3.1.18.7 Hydraulic system shall have double acting anti-drift check valves on blade lift, tilt, circle shift, articulation, leaning wheels, and scarifier.

3.1.19 Circle and Moldboard

3.1.19.1 The moldboard circle and drawbar assembly shall be such as to permit the grader to perform all operations specified herein and shall be attached to the frame by a swivel hitch mechanism.

3.1.19.2 Moldboard shall be equipped with a hydraulically operated side shift to the right and left of center position.

3.1.19.3 Moldboard controls shall provide a float position.

3.1.19.4 Moldboard shall be constructed of high carbon steel or alloy steel securely mounted and designed to give a rolling tumble of material.

3.1.19.5 Moldboard dimensions shall be as follows:

- A. Length – 12- feet minimum
- B. Width (measured along curve) 2- feet minimum
- C. Thickness – 7/8 inches minimum
- D. Maximum depth of cut – up to 28- inches
- E. Lift above ground level – 16.8 inches minimum
- F. Bank sloping angle - 90°left minimum and 90° right minimum.

3.1.19.6 Moldboard shall be punched for standard replaceable cutting blades and replaceable end bits.

3.1.19.7 All holes for cutting edges shall be drilled or punched to accommodate a standard ¾ inch plow bolt with hex nut.

3.1.19.8 The moldboard circle shall be provided with shims or other adequate means of adjustment for wear.

**WWREQUEST FOR QUOTATION
(Class 405) Motor Grader Articulated All Wheel Drive w/ Reversible Front Mounted
Trip/Plow John Deere 672 AWD or Equal**

3.1.19.9 A hydraulically operated power tilt moldboard shall be furnished.

3.1.19.10 The design of the moldboard shall be such that full 360° rotation can be accomplished with the blade slightly raised without manipulation of controls other than power shifting to clear tires, transmission or other integral parts of the machine.

3.1.19.11 Unit shall be equipped with manufacturers blade lift accumulators and side shift accumulators.

3.1.19.12 Unit shall be equipped with a blade impact absorption system to protect moldboard and draft frame from impact with stationary objects

3.1.20 Scarifier

3.1.20.1 A scarifier shall be furnished with each grader; front mounted.

3.1.20.2 Scarifier shall be of the V-type, power control operated, and must be equipped with removable teeth having replaceable points.

3.1.20.3 Scarifier cutting width 47.4 inches minimum.

3.1.20.4 Number of teeth – 5 minimum

3.1.20.5 Weight – 865 lbs. minimum.

3.1.20.6 Scarifier must allow grader to ditch when in raised position (Swinging Scarifier is not acceptable).

3.1.20.7 Scarifier shall be manufacturers standard for model bid, mounted on front of grader.

3.1.21 ROPS Cab (Low Profile)

3.1.21.1 The graders shall be furnished with R.O.P.S Cab.

3.1.21.2 Cabs shall be completely enclosed, with door on each side, constructed of heavy gauge material and shall be equipped

WWREQUEST FOR QUOTATION
(Class 405) Motor Grader Articulated All Wheel Drive w/ Reversible Front Mounted
Trip/Plow John Deere 672 AWD or Equal

with manufacturers tinted safety glass at all locations to provide 360° visibility.

3.1.21.3 All controls for operating and steering shall be mounted inside of cab.

3.1.21.4 The cab door shall be lockable, keyed alike, and provided with fasteners to hold doors open during operation.

3.1.21.5 Windshield and rear window shall be provided with manufacturers electrically operated windshield wipers and washers.

3.1.21.6 An adjustable review convex mirror shall be provided and mounted inside cab and heated exterior mounted rearview mirrors to afford a clear vision to the rear of the grader.

3.1.21.7 Cab shall have heat and air; and also, front and rear windshield defroster.

3.1.21.8 Instrument panel shall be located convenient to the seated operator.

3.1.21.9 A warning horn shall be furnished and mounted at the front of the operator's compartment with the horn switch within easy reach of the operator.

3.1.21.10 Manufacturers OSHA approved backup alarm shall be provided.

3.1.21.11 Manufacturers standard instrumentation shall be furnished but to include a positive means of monitoring vital systems. Shall include the following:

- A. Engine Oil Pressure
- B. Engine Coolant Temperature
- C. Electrical System
- D. Torque Converter Temperatures
- E. Transmission Pressure (If applicable)
- F. Hydraulic Oil Temperature

WWREQUEST FOR QUOTATION
(Class 405) Motor Grader Articulated All Wheel Drive w/ Reversible Front Mounted
Trip/Plow John Deere 672 AWD or Equal

3.1.21.12 Manufacturers warnings: Audio and/or lights shall be required on engine oil pressure, engine coolant temperature, and electrical system.

3.1.21.13 Seat shall be heated leather/fabric, with high wide back air-suspension seat with armrest.

3.1.22 Grader Equipment and Accessories

3.1.22.1 Vandalism protection kit shall include locking caps for all exposed filler caps.

3.1.22.2 Tool box shall be weather resistant, lockable.

3.1.22.3 Shall have articulation position indicator.

3.1.22.4 Shall have hour meter at dash board location (engine oil pressure activated).

3.1.22.5 Shall have air cleaner rain cap.

3.1.22.6 Shall have dash mounted air filter service indicator.

3.1.22.7 Shall have engine block heater; thermostat controlled.

3.1.22.8 Shall have deflector type exhaust stack.

3.1.22.9 Shall provide muffler.

3.1.22.10 Shall have fuel gauge dial type dash mounted.

3.1.22.11 Shall have AM/FM radio with wireless connectivity installed complete with antenna mounted in such a manner as to prevent being damaged by tree limbs, etc.

3.1.22.12 Shall have a manufacturer installed pressurized cab air conditioning system.

3.1.22.13 Shall include an amber LED high strobe beacon.

3.1.22.14 Shall have a rear view back up camera factory installed.

WWREQUEST FOR QUOTATION
(Class 405) Motor Grader Articulated All Wheel Drive w/ Reversible Front Mounted
Trip/Plow John Deere 672 AWD or Equal

3.1.22.15 Shall be equipped with a minimum of 5 -tie downs for transporting.

3.1.23 Paint

3.1.23.1 The motor grader and attachments shall be painted manufacturers standard color.

3.1.24 Safety

3.1.24.1 All exposed parts subject to high operating temperature or energized electrically shall be located, insulated, enclosed, or guarded so as to prevent hazards to operating personnel.

3.1.24.2 All moving parts which are of such nature or so located as to be a hazard to operating personnel shall be enclosed or guarded.

3.1.24.3 Protective devices shall not impair operating functions.

3.1.24.4 Handles and non-skid steps shall be of size, shape, and location to permit safe mounting and dismounting.

3.2 Hydraulically Controlled Reversible Front Mounted Snowplow

3.2.1 General

3.2.1.1 The hydraulically controlled reversible front mounted snow plows shall be designed to fit and be fully compatible with the proposed motor graders. The plow shall be designed for use in snow and light earthmoving, and blade must accept machine down pressure.

3.2.1.2 Blades shall be complete with all necessary cab controls and mounting hardware.

3.2.2 Specifications for Plow

3.2.2.1 Manufacturer's standard warranty shall be provided.

WWREQUEST FOR QUOTATION
(Class 405) Motor Grader Articulated All Wheel Drive w/ Reversible Front Mounted
Trip/Plow John Deere 672 AWD or Equal

3.2.2.2 Moldboard length shall be straight 12-feet minimum.

3.2.2.3 Moldboard height: 36-inches minimum.

3.2.2.4 Moldboard shall have a minimum of two heavy duty enclosed trip spring assemblies.

3.2.3 Reversing Cylinders

3.2.3.1 Plow shall consist of two (2) double acting hydraulic cylinders.

3.2.3.2 These cylinders shall be capable of reversing the plow from 35° right and 35° left minimum.

3.2.3.3 Cylinder mounting pins shall be minimum of one (1) inch diameter.

3.2.4 Cushion Valves

3.2.4.1 A cushion valve shall be included in the hydraulic reversing system as a safety factor to help protect the cylinder.

3.2.5 Cutting Edge

3.2.5.1 Cutting edge shall be 5/8 x 8 inches x 120 inches minimum and shall be compatible with the plow.

3.2.6 Wear Shoes

3.2.6.1 Wear shoes must number at least two (2).

3.2.7 Vertical Ribs

3.2.7.1 Must have a minimum of five (5) vertical ribs.

3.2.8 Hitch

3.2.8.1 Must have front mounted, Stainless Steel quick coupler, coupling system.

**WWREQUEST FOR QUOTATION
(Class 405) Motor Grader Articulated All Wheel Drive w/ Reversible Front Mounted
Trip/Plow John Deere 672 AWD or Equal**

3.3 Miscellaneous:

3.3.1 Vendor Responsibility

3.3.1.1 The vendor shall be responsible to furnish a Motor Grader Articulated All Wheel Drive w/Reversible Front Mounted Trip/Plow that is properly engineered and that conforms to all and any laws governing such equipment.

3.3.1.2 Unspecified Accessories & Features: All parts, equipment, accessories, material, design and performance characteristics not specified herein, but which are necessary to provide a complete unit, must be furnished with each unit and required to conform to strength, quality of material, and quality of workmanship to those which are advertised and provided to the market in general by the unit industry.

3.3.1.3 All parts and accessories advertised and regularly supplied as standard shall be included, except those which would represent duplication of these specified and except those which, by specification, are not to be furnished.

3.3.1.4 All standard safety features required by Federal and State Law, shall be included.

3.3.1.5 Inspection: WVDOH requires unit shall have a West Virginia State inspection sticker upon delivery.

3.3.1.6 Unit shall be delivered: to WVDOH with all manufacturers recommended safety related decals and safety features intact.

3.3.2 Representative Unit for Test:

3.3.2.1 The successful vendor must (if specified) provide the DOH one (1) completed represented unit to be observed and evaluated on each order to

**WWREQUEST FOR QUOTATION
(Class 405) Motor Grader Articulated All Wheel Drive w/ Reversible Front Mounted
Trip/Plow John Deere 672 AWD or Equal**

insure compliance with specification. If requested, the time period for testing and evaluation shall be seven (7) working days following receipt of the unit. DOH will incur no obligation for deterioration of surfaces, finishes, seals, and mechanical or electrical parts on the unit resulting from operation and testing within the limits of these specifications; nor will DOH incur obligation for damage to the unit resulting from failure to meet specifications when due care and attention is given by DOH and testing is done within the limits of these specifications. Failure of the pilot unit to satisfactorily meet specifications as bid may be cause for cancellation of the purchase order and return of the delivered unit along with all associated equipment to the vendor at the vendor's expense.

3.3.3 Operating and Service Manuals and Parts Lists:

3.3.3.1 An operator's manual must be included with each unit upon delivery. A "line sheet" (if applicable) and the "Equipment Preventative Maintenance Questionnaire", (Exhibit "B") must be with pilot unit upon delivery, Attn: Todd Campbell. There must be 12 service/shop/maintenance manuals and 14 parts manuals; USB storage drive is preferred in lieu of parts manuals. Manuals and USB storage drive shall be delivered upon completion of delivery of total units. Failure to do so will delay payment.

3.3.4 Training:

3.3.4.1 Manufacturers and/or dealers will be required to stage a thorough seminar on the subjects of Preventative Maintenance, Operator, and Mechanic Training. In order to keep operators and mechanics updated, the successful vendor shall conduct training sessions covering the operation, maintenance, trouble- shooting with each purchase order against this open end contract.

Manufacturers and/or dealers shall be required to furnish the Training Academy with one (1) Operator's Manual to be shipped direct to

WWREQUEST FOR QUOTATION
(Class 405) Motor Grader Articulated All Wheel Drive w/ Reversible Front Mounted
Trip/Plow John Deere 672 AWD or Equal

WVDOH
Training Academy
P.O. Box 610
Buckhannon, West Virginia 26201

Prior to delivery of the pilot unit. Training seminar to be held at the
WVDOT, Equipment Division, Buckhannon, WV.

3.3.5 Preventative Maintenance & Operator Procedures:

3.3.5.1 Manufacturers and/or dealers will be required to submit to the
Equipment Division, in addition to the operating and service manuals,
booklets and pamphlets explaining the Preventative Maintenance and
Operator Procedures to be used by the operators of this equipment, and
must include such things as daily prestart inspection procedure, service
schedule, and routine maintenance required, safety precautions, etc. The
successful vendor shall furnish all training aids; i.e. videos, projectors as
required in conducting the training.

3.3.6 Warranty and Service Policy:

3.3.6.1 The bid shall include a breakdown of the complete manufacturer's
warranty per section. The unit must be accompanied upon delivery by the
unit's manufacturers executed warranty and service policy.

4. CONTRACT AWARD:

4.1 Contract Award: The Contract is intended to provide Agencies with a
purchase price on all Contract Items. The Contract shall be awarded to the
Vendor that provides the Contract Items meeting the required specifications
for the lowest overall total cost as shown on the Pricing Pages.

4.2 Pricing Pages: Vendor should complete the Pricing Pages (Exhibit A) by
inserting the Year, Make, Model and inserting the quoted unit price. Vendor
should take Estimated Quantity and multiply by unit price to get grand total.

**WWREQUEST FOR QUOTATION
(Class 405) Motor Grader Articulated All Wheel Drive w/ Reversible Front Mounted
Trip/Plow John Deere 672 AWD or Equal**

Vendor should complete the Pricing Pages in their entirety as failure to do so may result in Vendor's bids being disqualified.

The Pricing Pages contain a list of the Contract Items and estimated purchase volume. The estimated purchase volume for each item represents the approximate volume of anticipated purchases only. No future use of the Contract or any individual item is guaranteed or implied.

Vendor should electronically enter the information into the Pricing Pages through wvOASIS, if available, or as an electronic document. In most cases, the Vendor can request an electronic copy of the Pricing Pages for bid purposes by sending an email request to the following address: john.w.estep@wv.gov.

5. ORDERING AND PAYMENT:

- 5.1 Ordering:** Vendor shall accept orders through wvOASIS, regular mail, facsimile, e-mail, or any other written form of communication. Vendor may, but is not required to, accept on-line orders through a secure internet ordering portal/website. If Vendor has the ability to accept on-line orders, it should include in its response a brief description of how Agencies may utilize the on-line ordering system. Vendor shall ensure that its on-line ordering system is properly secured prior to processing Agency orders on-line.
- 5.2 Payment:** Vendor shall accept payment in accordance with the payment procedures of the State of West Virginia.

6. DELIVERY AND RETURN:

- 6.1 Delivery Time:** A completed pilot model for inspection must be provided within **120** working day(s) after receipt of the pilot model order, by the successful vendor. Vendor shall deliver standard orders within **180** working days after orders are received Working day is defined as any week day, Monday thru Friday, excluding Federal and State Holidays. Vendor shall ship all orders until a minimum delivery quantity is met.
- 6.2 Late Delivery:** The Agency placing the order under this Contract must be notified in writing if orders will be delayed for any reason. Any delay in delivery that could cause harm to an Agency will be grounds for cancellation of the delayed order, and/or obtaining

WWREQUEST FOR QUOTATION
**(Class 405) Motor Grader Articulated All Wheel Drive w/ Reversible Front Mounted
Trip/Plow John Deere 672 AWD or Equal**

the items ordered from a third party.

Any Agency seeking to obtain items from a third party under this provision must first obtain approval of the Purchasing Division.

6.3 Delivery Payment/Risk of Loss: Standard order delivery shall be F.O.B. destination to the Agency's location. Vendor shall include the cost of standard order delivery charges in its bid pricing/discount and is not permitted to charge the Agency separately for such delivery.

6.4 Conditions of Unit(s) Upon Delivery: All units must arrive at the prescribed delivery point having been completely pre-serviced with oil, lubricants, and coolant. All prescribed precautions pertaining to first operations and break-in of the unit are to be posted conspicuously on the unit for ready observance by the operator. All units shall be delivered to WVDOH with all manufacturers recommended safety related decals and safety features intact.

6.5 Delivery Point: Delivery point of the completed representative unit will be the WVDOH, Equipment Division, 83 Brushy Fork Road Crossing, Buckhannon, WV 26201.

7. VENDOR DEFAULT:

7.1 The following shall be considered a vendor default under this Contract.

7.1.1 Failure to provide Contract Items in accordance with the requirements contained herein.

7.1.2 Failure to comply with other specifications and requirements contained herein.

7.1.3 Failure to comply with any laws, rules, and ordinances applicable to the Contract Services provided under this Contract.

7.1.4 Failure to remedy deficient performance upon request.

7.2 The following remedies shall be available to Agency upon default.

7.2.1 Immediate cancellation of the Contract.

7.2.2 Immediate cancellation of one or more release orders issued under this Contract.

WWREQUEST FOR QUOTATION
(Class 405) Motor Grader Articulated All Wheel Drive w/ Reversible Front Mounted
Trip/Plow John Deere 672 AWD or Equal

7.2.3 Any other remedies available in law or equity.

8. MISCELLANEOUS:

- 8.1 No Substitutions:** Vendor shall supply only Contract Items submitted in response to the Solicitation unless a contract modification is approved in accordance with the provisions contained in this Contract.
- 8.2 Reports:** Vendor shall provide quarterly reports and annual summaries to the Agency showing the Agency's items purchased, quantities of items purchased, and total dollar value of the items purchased. Vendor shall also provide reports, upon request, showing the items purchased during the term of this Contract, the quantity purchased for each of those items, and the total value of purchases for each of those items. Failure to supply such reports may be grounds for cancellation of this Contract.
- 8.3 Contract Manager:** During its performance of this Contract, Vendor must designate and maintain a primary contract manager responsible for overseeing Vendor's responsibilities under this Contract. The Contract manager must be available during normal business hours to address any customer service or other issues related to this Contract. Vendor should list its Contract manager and his or her contact information below.

Contract Manager: Tom Schanz
Telephone Number: 404-230-3728
Fax Number: N/A
Email Address: TSCCHANZ@sanymerica.com

GENERAL TERMS AND CONDITIONS:

1. CONTRACTUAL AGREEMENT: Issuance of a Award Document signed by the Purchasing Division Director, or his designee, and approved as to form by the Attorney General's office constitutes acceptance of this Contract made by and between the State of West Virginia and the Vendor. Vendor's signature on its bid signifies Vendor's agreement to be bound by and accept the terms and conditions contained in this Contract.

2. DEFINITIONS: As used in this Solicitation/Contract, the following terms shall have the meanings attributed to them below. Additional definitions may be found in the specifications included with this Solicitation/Contract.

2.1. "Agency" or "Agencies" means the agency, board, commission, or other entity of the State of West Virginia that is identified on the first page of the Solicitation or any other public entity seeking to procure goods or services under this Contract.

2.2. "Bid" or "Proposal" means the vendors submitted response to this solicitation.

2.3. "Contract" means the binding agreement that is entered into between the State and the Vendor to provide the goods or services requested in the Solicitation.

2.4. "Director" means the Director of the West Virginia Department of Administration, Purchasing Division.

2.5. "Purchasing Division" means the West Virginia Department of Administration, Purchasing Division.

2.6. "Award Document" means the document signed by the Agency and the Purchasing Division, and approved as to form by the Attorney General, that identifies the Vendor as the contract holder.

2.7. "Solicitation" means the official notice of an opportunity to supply the State with goods or services that is published by the Purchasing Division.

2.8. "State" means the State of West Virginia and/or any of its agencies, commissions, boards, etc. as context requires.

2.9. "Vendor" or "Vendors" means any entity submitting a bid in response to the Solicitation, the entity that has been selected as the lowest responsible bidder, or the entity that has been awarded the Contract as context requires.

4. AUTHORITY TO PROCEED: Vendor is authorized to begin performance of this contract on the date of encumbrance listed on the front page of the Award Document unless either the box for “Fixed Period Contract” or “Fixed Period Contract with Renewals” has been checked in Section 3 above. If either “Fixed Period Contract” or “Fixed Period Contract with Renewals” has been checked, Vendor must not begin work until it receives a separate notice to proceed from the State. The notice to proceed will then be incorporated into the contract via change order to memorialize the official date that work commenced.

5. QUANTITIES: The quantities required under this Contract shall be determined in accordance with the category that has been identified as applicable to this Contract below.

Open End Contract: Quantities listed in this Solicitation are approximations only, based on estimates supplied by the Agency. It is understood and agreed that the Contract shall cover the quantities actually ordered for delivery during the term of the Contract, whether more or less than the quantities shown.

Service: The scope of the service to be provided will be more clearly defined in the specifications included herewith.

Combined Service and Goods: The scope of the service and deliverable goods to be provided will be more clearly defined in the specifications included herewith.

One Time Purchase: This Contract is for the purchase of a set quantity of goods that are identified in the specifications included herewith. Once those items have been delivered, no additional goods may be procured under this Contract without an appropriate change order approved by the Vendor, Agency, Purchasing Division, and Attorney General’s office.

6. EMERGENCY PURCHASES: The Purchasing Division Director may authorize the Agency to purchase goods or services in the open market that Vendor would otherwise provide under this Contract if those goods or services are for immediate or expedited delivery in an emergency. Emergencies shall include, but are not limited to, delays in transportation or an unanticipated increase in the volume of work. An emergency purchase in the open market, approved by the Purchasing Division Director, shall not constitute of breach of this Contract and shall not entitle the Vendor to any form of compensation or damages. This provision does not excuse the State from fulfilling its obligations under a One Time Purchase contract.

7. REQUIRED DOCUMENTS: All of the items checked below must be provided to the Purchasing Division by the Vendor as specified below.

BID BOND (Construction Only): Pursuant to the requirements contained in W. Va. Code § 5-22-1(c), All Vendors submitting a bid on a construction project shall furnish a valid bid bond in the amount of five percent (5%) of the total amount of the bid protecting the State of West Virginia. The bid bond must be submitted with the bid.

PERFORMANCE BOND: The apparent successful Vendor shall provide a performance bond in the amount of 100% of the contract. The performance bond must be received by the Purchasing Division prior to Contract award.

LABOR/MATERIAL PAYMENT BOND: The apparent successful Vendor shall provide a labor/material payment bond in the amount of 100% of the Contract value. The labor/material payment bond must be delivered to the Purchasing Division prior to Contract award.

In lieu of the Bid Bond, Performance Bond, and Labor/Material Payment Bond, the Vendor may provide certified checks, cashier's checks, or irrevocable letters of credit. Any certified check, cashier's check, or irrevocable letter of credit provided in lieu of a bond must be of the same amount and delivered on the same schedule as the bond it replaces. A letter of credit submitted in lieu of a performance and labor/material payment bond will only be allowed for projects under \$100,000. Personal or business checks are not acceptable. Notwithstanding the foregoing, West Virginia Code § 5-22-1 (d) mandates that a vendor provide a performance and labor/material payment bond for construction projects. Accordingly, substitutions for the performance and labor/material payment bonds for construction projects is not permitted.

MAINTENANCE BOND: The apparent successful Vendor shall provide a two (2) year maintenance bond covering the roofing system. The maintenance bond must be issued and delivered to the Purchasing Division prior to Contract award.

LICENSE(S) / CERTIFICATIONS / PERMITS: In addition to anything required under the Section of the General Terms and Conditions entitled Licensing, the apparent successful Vendor shall furnish proof of the following licenses, certifications, and/or permits upon request and in a form acceptable to the State. The request may be prior to or after contract award at the State's sole discretion.

The apparent successful Vendor shall also furnish proof of any additional licenses or certifications contained in the specifications regardless of whether or not that requirement is listed above.

8. INSURANCE: The apparent successful Vendor shall furnish proof of the insurance identified by a checkmark below and must include the State as an additional insured on each policy prior to Contract award. The insurance coverages identified below must be maintained throughout the life of this contract. Thirty (30) days prior to the expiration of the insurance policies, Vendor shall provide the Agency with proof that the insurance mandated herein has been continued. Vendor must also provide Agency with immediate notice of any changes in its insurance policies, including but not limited to, policy cancelation, policy reduction, or change in insurers. The apparent successful Vendor shall also furnish proof of any additional insurance requirements contained in the specifications prior to Contract award regardless of whether or not that insurance requirement is listed in this section.

Vendor must maintain:

Commercial General Liability Insurance in at least an amount of: \$1,000,000.00 per occurrence.

Automobile Liability Insurance in at least an amount of: \$1,000,000.00 per occurrence.

Professional/Malpractice/Errors and Omission Insurance in at least an amount of: _____ per occurrence. Notwithstanding the forgoing, Vendor's are not required to list the State as an additional insured for this type of policy.

Commercial Crime and Third Party Fidelity Insurance in an amount of: _____ per occurrence.

Cyber Liability Insurance in an amount of: _____ per occurrence.

Builders Risk Insurance in an amount equal to 100% of the amount of the Contract.

Pollution Insurance in an amount of: _____ per occurrence.

Aircraft Liability in an amount of: _____ per occurrence.

*****Please make insurance certificate to read as follows:**
State of WV, 1900 Kanawha Blvd E, Bldg 5, Charleston, WV 25305

*****State of WV must be listed as additional insured.**

Notwithstanding anything contained in this section to the contrary, the Director of the Purchasing Division reserves the right to waive the requirement that the State be named as an additional insured on one or more of the Vendor's insurance policies if the Director finds that doing so is in the State's best interest.

9. WORKERS' COMPENSATION INSURANCE: The apparent successful Vendor shall comply with laws relating to workers compensation, shall maintain workers' compensation insurance when required, and shall furnish proof of workers' compensation insurance upon request.

10. [Reserved]

11. LIQUIDATED DAMAGES: This clause shall in no way be considered exclusive and shall not limit the State or Agency's right to pursue any other available remedy. Vendor shall pay liquidated damages in the amount specified below or as described in the specifications:

_____ for _____

Liquidated Damages Contained in the Specifications

12. ACCEPTANCE: Vendor's signature on its bid, or on the certification and signature page, constitutes an offer to the State that cannot be unilaterally withdrawn, signifies that the product or service proposed by vendor meets the mandatory requirements contained in the Solicitation for that product or service, unless otherwise indicated, and signifies acceptance of the terms and conditions contained in the Solicitation unless otherwise indicated.

13. PRICING: The pricing set forth herein is firm for the life of the Contract, unless specified elsewhere within this Solicitation/Contract by the State. A Vendor's inclusion of price adjustment provisions in its bid, without an express authorization from the State in the Solicitation to do so, may result in bid disqualification. Notwithstanding the foregoing, Vendor must extend any publicly advertised sale price to the State and invoice at the lower of the contract price or the publicly advertised sale price.

14. PAYMENT IN ARREARS: Payment in advance is prohibited under this Contract. Payment may only be made after the delivery and acceptance of goods or services. The Vendor shall submit invoices, in arrears.

15. PAYMENT METHODS: Vendor must accept payment by electronic funds transfer and P-Card. (The State of West Virginia's Purchasing Card program, administered under contract by a banking institution, processes payment for goods and services through state designated credit cards.)

16. TAXES: The Vendor shall pay any applicable sales, use, personal property or any other taxes arising out of this Contract and the transactions contemplated thereby. The State of West Virginia is exempt from federal and state taxes and will not pay or reimburse such taxes.

17. ADDITIONAL FEES: Vendor is not permitted to charge additional fees or assess additional charges that were not either expressly provided for in the solicitation published by the State of West Virginia or included in the unit price or lump sum bid amount that Vendor is required by the solicitation to provide. Including such fees or charges as notes to the solicitation may result in rejection of vendor's bid. Requesting such fees or charges be paid after the contract has been awarded may result in cancellation of the contract.

18. FUNDING: This Contract shall continue for the term stated herein, contingent upon funds being appropriated by the Legislature or otherwise being made available. In the event funds are not appropriated or otherwise made available, this Contract becomes void and of no effect beginning on July 1 of the fiscal year for which funding has not been appropriated or otherwise made available.

19. CANCELLATION: The Purchasing Division Director reserves the right to cancel this Contract immediately upon written notice to the vendor if the materials or workmanship supplied do not conform to the specifications contained in the Contract. The Purchasing Division Director may also cancel any purchase or Contract upon 30 days written notice to the Vendor in accordance with West Virginia Code of State Rules § 148-1-5.2.b.

20. TIME: Time is of the essence with regard to all matters of time and performance in this Contract.

21. APPLICABLE LAW: This Contract is governed by and interpreted under West Virginia law without giving effect to its choice of law principles. Any information provided in specification manuals, or any other source, verbal or written, which contradicts or violates the West Virginia Constitution, West Virginia Code or West Virginia Code of State Rules is void and of no effect.

22. COMPLIANCE WITH LAWS: Vendor shall comply with all applicable federal, state, and local laws, regulations and ordinances. By submitting a bid, Vendor acknowledges that it has reviewed, understands, and will comply with all applicable laws, regulations, and ordinances.

SUBCONTRACTOR COMPLIANCE: Vendor shall notify all subcontractors providing commodities or services related to this Contract that as subcontractors, they too are required to comply with all applicable laws, regulations, and ordinances. Notification under this provision must occur prior to the performance of any work under the contract by the subcontractor.

23. ARBITRATION: Any references made to arbitration contained in this Contract, Vendor's bid, or in any American Institute of Architects documents pertaining to this Contract are hereby deleted, void, and of no effect.

24. MODIFICATIONS: This writing is the parties' final expression of intent. Notwithstanding anything contained in this Contract to the contrary no modification of this Contract shall be binding without mutual written consent of the Agency, and the Vendor, with approval of the Purchasing Division and the Attorney General's office (Attorney General approval is as to form only). Any change to existing contracts that adds work or changes contract cost, and were not included in the original contract, must be approved by the Purchasing Division and the Attorney General's Office (as to form) prior to the implementation of the change or commencement of work affected by the change.

25. WAIVER: The failure of either party to insist upon a strict performance of any of the terms or provision of this Contract, or to exercise any option, right, or remedy herein contained, shall not be construed as a waiver or a relinquishment for the future of such term, provision, option, right, or remedy, but the same shall continue in full force and effect. Any waiver must be expressly stated in writing and signed by the waiving party.

26. SUBSEQUENT FORMS: The terms and conditions contained in this Contract shall supersede any and all subsequent terms and conditions which may appear on any form documents submitted by Vendor to the Agency or Purchasing Division such as price lists, order forms, invoices, sales agreements, or maintenance agreements, and includes internet websites or other electronic documents. Acceptance or use of Vendor's forms does not constitute acceptance of the terms and conditions contained thereon.

27. ASSIGNMENT: Neither this Contract nor any monies due, or to become due hereunder, may be assigned by the Vendor without the express written consent of the Agency, the Purchasing Division, the Attorney General's office (as to form only), and any other government agency or office that may be required to approve such assignments.

28. WARRANTY: The Vendor expressly warrants that the goods and/or services covered by this Contract will: (a) conform to the specifications, drawings, samples, or other description furnished or specified by the Agency; (b) be merchantable and fit for the purpose intended; and (c) be free from defect in material and workmanship.

29. STATE EMPLOYEES: State employees are not permitted to utilize this Contract for personal use and the Vendor is prohibited from permitting or facilitating the same.

30. PRIVACY, SECURITY, AND CONFIDENTIALITY: The Vendor agrees that it will not disclose to anyone, directly or indirectly, any such personally identifiable information or other confidential information gained from the Agency, unless the individual who is the subject of the information consents to the disclosure in writing or the disclosure is made pursuant to the Agency's policies, procedures, and rules. Vendor further agrees to comply with the Confidentiality Policies and Information Security Accountability Requirements, set forth in <http://www.state.wv.us/admin/purchase/privacy/default.html>.

31. YOUR SUBMISSION IS A PUBLIC DOCUMENT: Vendor's entire response to the Solicitation and the resulting Contract are public documents. As public documents, they will be disclosed to the public following the bid/proposal opening or award of the contract, as required by the competitive bidding laws of West Virginia Code §§ 5A-3-1 et seq., 5-22-1 et seq., and 5G-1-1 et seq. and the Freedom of Information Act West Virginia Code §§ 29B-1-1 et seq.

DO NOT SUBMIT MATERIAL YOU CONSIDER TO BE CONFIDENTIAL, A TRADE SECRET, OR OTHERWISE NOT SUBJECT TO PUBLIC DISCLOSURE.

Submission of any bid, proposal, or other document to the Purchasing Division constitutes your explicit consent to the subsequent public disclosure of the bid, proposal, or document. The Purchasing Division will disclose any document labeled "confidential," "proprietary," "trade secret," "private," or labeled with any other claim against public disclosure of the documents, to include any "trade secrets" as defined by West Virginia Code § 47-22-1 et seq. All submissions are subject to public disclosure without notice.

32. LICENSING: In accordance with West Virginia Code of State Rules § 148-1-6.1.e, Vendor must be licensed and in good standing in accordance with any and all state and local laws and requirements by any state or local agency of West Virginia, including, but not limited to, the West Virginia Secretary of State's Office, the West Virginia Tax Department, West Virginia Insurance Commission, or any other state agency or political subdivision. Obligations related to political subdivisions may include, but are not limited to, business licensing, business and occupation taxes, inspection compliance, permitting, etc. Upon request, the Vendor must provide all necessary releases to obtain information to enable the Purchasing Division Director or the Agency to verify that the Vendor is licensed and in good standing with the above entities.

SUBCONTRACTOR COMPLIANCE: Vendor shall notify all subcontractors providing commodities or services related to this Contract that as subcontractors, they too are required to be licensed, in good standing, and up-to-date on all state and local obligations as described in this section. Obligations related to political subdivisions may include, but are not limited to, business licensing, business and occupation taxes, inspection compliance, permitting, etc. Notification under this provision must occur prior to the performance of any work under the contract by the subcontractor.

33. ANTITRUST: In submitting a bid to, signing a contract with, or accepting a Award Document from any agency of the State of West Virginia, the Vendor agrees to convey, sell, assign, or transfer to the State of West Virginia all rights, title, and interest in and to all causes of action it may now or hereafter acquire under the antitrust laws of the United States and the State of West Virginia for price fixing and/or unreasonable restraints of trade relating to the particular commodities or services purchased or acquired by the State of West Virginia. Such assignment shall be made and become effective at the time the purchasing agency tenders the initial payment to Vendor.

34. VENDOR CERTIFICATIONS: By signing its bid or entering into this Contract, Vendor certifies (1) that its bid or offer was made without prior understanding, agreement, or connection with any corporation, firm, limited liability company, partnership, person or entity submitting a bid or offer for the same material, supplies, equipment or services; (2) that its bid or offer is in all respects fair and without collusion or fraud; (3) that this Contract is accepted or entered into without any prior understanding, agreement, or connection to any other entity that could be considered a violation of law; and (4) that it has reviewed this Solicitation in its entirety; understands the requirements, terms and conditions, and other information contained herein.

Vendor's signature on its bid or offer also affirms that neither it nor its representatives have any interest, nor shall acquire any interest, direct or indirect, which would compromise the performance of its services hereunder. Any such interests shall be promptly presented in detail to the Agency. The individual signing this bid or offer on behalf of Vendor certifies that he or she is authorized by the Vendor to execute this bid or offer or any documents related thereto on Vendor's behalf; that he or she is authorized to bind the Vendor in a contractual relationship; and that, to the best of his or her knowledge, the Vendor has properly registered with any State agency that may require registration.

35. VENDOR RELATIONSHIP: The relationship of the Vendor to the State shall be that of an independent contractor and no principal-agent relationship or employer-employee relationship is contemplated or created by this Contract. The Vendor as an independent contractor is solely liable for the acts and omissions of its employees and agents. Vendor shall be responsible for selecting, supervising, and compensating any and all individuals employed pursuant to the terms of this Solicitation and resulting contract. Neither the Vendor, nor any employees or subcontractors of the Vendor, shall be deemed to be employees of the State for any purpose whatsoever. Vendor shall be exclusively responsible for payment of employees and contractors for all wages and salaries, taxes, withholding payments, penalties, fees, fringe benefits, professional liability insurance premiums, contributions to insurance and pension, or other deferred compensation plans, including but not limited to, Workers' Compensation and Social Security obligations, licensing fees, etc. and the filing of all necessary documents, forms, and returns pertinent to all of the foregoing.

Vendor shall hold harmless the State, and shall provide the State and Agency with a defense against any and all claims including, but not limited to, the foregoing payments, withholdings, contributions, taxes, Social Security taxes, and employer income tax returns.

36. INDEMNIFICATION: The Vendor agrees to indemnify, defend, and hold harmless the State and the Agency, their officers, and employees from and against: (1) Any claims or losses for services rendered by any subcontractor, person, or firm performing or supplying services, materials, or supplies in connection with the performance of the Contract; (2) Any claims or losses resulting to any person or entity injured or damaged by the Vendor, its officers, employees, or subcontractors by the publication, translation, reproduction, delivery, performance, use, or disposition of any data used under the Contract in a manner not authorized by the Contract, or by Federal or State statutes or regulations; and (3) Any failure of the Vendor, its officers, employees, or subcontractors to observe State and Federal laws including, but not limited to, labor and wage and hour laws.

37. PURCHASING AFFIDAVIT: In accordance with West Virginia Code §§ 5A-3-10a and 5-22-1(i), the State is prohibited from awarding a contract to any bidder that owes a debt to the State or a political subdivision of the State, Vendors are required to sign, notarize, and submit the Purchasing Affidavit to the Purchasing Division affirming under oath that it is not in default on any monetary obligation owed to the state or a political subdivision of the state.

38. ADDITIONAL AGENCY AND LOCAL GOVERNMENT USE: This Contract may be utilized by other agencies, spending units, and political subdivisions of the State of West Virginia; county, municipal, and other local government bodies; and school districts (“Other Government Entities”), provided that both the Other Government Entity and the Vendor agree. Any extension of this Contract to the aforementioned Other Government Entities must be on the same prices, terms, and conditions as those offered and agreed to in this Contract, provided that such extension is in compliance with the applicable laws, rules, and ordinances of the Other Government Entity. A refusal to extend this Contract to the Other Government Entities shall not impact or influence the award of this Contract in any manner.

39. CONFLICT OF INTEREST: Vendor, its officers or members or employees, shall not presently have or acquire an interest, direct or indirect, which would conflict with or compromise the performance of its obligations hereunder. Vendor shall periodically inquire of its officers, members and employees to ensure that a conflict of interest does not arise. Any conflict of interest discovered shall be promptly presented in detail to the Agency.

40. REPORTS: Vendor shall provide the Agency and/or the Purchasing Division with the following reports identified by a checked box below:

Such reports as the Agency and/or the Purchasing Division may request. Requested reports may include, but are not limited to, quantities purchased, agencies utilizing the contract, total contract expenditures by agency, etc.

Quarterly reports detailing the total quantity of purchases in units and dollars, along with a listing of purchases by agency. Quarterly reports should be delivered to the Purchasing Division via email at purchasing.division@wv.gov.

41. BACKGROUND CHECK: In accordance with W. Va. Code § 15-2D-3, the Director of the Division of Protective Services shall require any service provider whose employees are regularly employed on the grounds or in the buildings of the Capitol complex or who have access to sensitive or critical information to submit to a fingerprint-based state and federal background inquiry through the state repository. The service provider is responsible for any costs associated with the fingerprint-based state and federal background inquiry.

After the contract for such services has been approved, but before any such employees are permitted to be on the grounds or in the buildings of the Capitol complex or have access to sensitive or critical information, the service provider shall submit a list of all persons who will be physically present and working at the Capitol complex to the Director of the Division of Protective Services for purposes of verifying compliance with this provision. The State reserves the right to prohibit a service provider’s employees from accessing sensitive or critical information or to be present at the Capitol complex based upon results addressed from a criminal background check.

Revised 02/10/2021

Service providers should contact the West Virginia Division of Protective Services by phone at (304) 558-9911 for more information.

42. PREFERENCE FOR USE OF DOMESTIC STEEL PRODUCTS: Except when authorized by the Director of the Purchasing Division pursuant to W. Va. Code § 5A-3-56, no contractor may use or supply steel products for a State Contract Project other than those steel products made in the United States. A contractor who uses steel products in violation of this section may be subject to civil penalties pursuant to W. Va. Code § 5A-3-56. As used in this section:

- a. “State Contract Project” means any erection or construction of, or any addition to, alteration of or other improvement to any building or structure, including, but not limited to, roads or highways, or the installation of any heating or cooling or ventilating plants or other equipment, or the supply of and materials for such projects, pursuant to a contract with the State of West Virginia for which bids were solicited on or after June 6, 2001.
- b. “Steel Products” means products rolled, formed, shaped, drawn, extruded, forged, cast, fabricated or otherwise similarly processed, or processed by a combination of two or more or such operations, from steel made by the open heath, basic oxygen, electric furnace, Bessemer or other steel making process. The Purchasing Division Director may, in writing, authorize the use of foreign steel products if:
- c. The cost for each contract item used does not exceed one tenth of one percent (.1%) of the total contract cost or two thousand five hundred dollars (\$2,500.00), whichever is greater. For the purposes of this section, the cost is the value of the steel product as delivered to the project; or
- d. The Director of the Purchasing Division determines that specified steel materials are not produced in the United States in sufficient quantity or otherwise are not reasonably available to meet contract requirements.

43. PREFERENCE FOR USE OF DOMESTIC ALUMINUM, GLASS, AND STEEL: In Accordance with W. Va. Code § 5-19-1 et seq., and W. Va. CSR § 148-10-1 et seq., for every contract or subcontract, subject to the limitations contained herein, for the construction, reconstruction, alteration, repair, improvement or maintenance of public works or for the purchase of any item of machinery or equipment to be used at sites of public works, only domestic aluminum, glass or steel products shall be supplied unless the spending officer determines, in writing, after the receipt of offers or bids, (1) that the cost of domestic aluminum, glass or steel products is unreasonable or inconsistent with the public interest of the State of West Virginia, (2) that domestic aluminum, glass or steel products are not produced in sufficient quantities to meet the contract requirements, or (3) the available domestic aluminum, glass, or steel do not meet the contract specifications. This provision only applies to public works contracts awarded in an amount more than fifty thousand dollars (\$50,000) or public works contracts that require more than ten thousand pounds of steel products.

The cost of domestic aluminum, glass, or steel products may be unreasonable if the cost is more than twenty percent (20%) of the bid or offered price for foreign made aluminum, glass, or steel products. If the domestic aluminum, glass or steel products to be supplied or produced in a

“substantial labor surplus area”, as defined by the United States Department of Labor, the cost of domestic aluminum, glass, or steel products may be unreasonable if the cost is more than thirty percent (30%) of the bid or offered price for foreign made aluminum, glass, or steel products. This preference shall be applied to an item of machinery or equipment, as indicated above, when the item is a single unit of equipment or machinery manufactured primarily of aluminum, glass or steel, is part of a public works contract and has the sole purpose or of being a permanent part of a single public works project. This provision does not apply to equipment or machinery purchased by a spending unit for use by that spending unit and not as part of a single public works project.

All bids and offers including domestic aluminum, glass or steel products that exceed bid or offer prices including foreign aluminum, glass or steel products after application of the preferences provided in this provision may be reduced to a price equal to or lower than the lowest bid or offer price for foreign aluminum, glass or steel products plus the applicable preference. If the reduced bid or offer prices are made in writing and supersede the prior bid or offer prices, all bids or offers, including the reduced bid or offer prices, will be reevaluated in accordance with this rule.

44. INTERESTED PARTY SUPPLEMENTAL DISCLOSURE: W. Va. Code § 6D-1-2 requires that for contracts with an actual or estimated value of at least \$1 million, the vendor must submit to the Agency a supplemental disclosure of interested parties reflecting any new or differing interested parties to the contract, which were not included in the original pre-award interested party disclosure, within 30 days following the completion or termination of the contract. A copy of that form is included with this solicitation or can be obtained from the WV Ethics Commission. This requirement does not apply to publicly traded companies listed on a national or international stock exchange. A more detailed definition of interested parties can be obtained from the form referenced above.

45. PROHIBITION AGAINST USED OR REFURBISHED: Unless expressly permitted in the solicitation published by the State, Vendor must provide new, unused commodities, and is prohibited from supplying used or refurbished commodities, in fulfilling its responsibilities under this Contract.

DESIGNATED CONTACT: Vendor appoints the individual identified in this Section as the Contract Administrator and the initial point of contact for matters relating to this Contract.

THOMAS SCHANZ - MANAGER MUNICIPAL SALES

(Name, Title)

Thomas Schanz Jr.

(Printed Name and Title)

318 Cooper circle, Peachtree City, GA 30269

(Address)

404-230-3728

(Phone Number) / (Fax Number)

T.SCHANZ@SanyAmerica.com

(email address)

CERTIFICATION AND SIGNATURE: By signing below, or submitting documentation through wvOASIS, I certify that I have reviewed this Solicitation in its entirety; that I understand the requirements, terms and conditions, and other information contained herein; that this bid, offer or proposal constitutes an offer to the State that cannot be unilaterally withdrawn; that the product or service proposed meets the mandatory requirements contained in the Solicitation for that product or service, unless otherwise stated herein; that the Vendor accepts the terms and conditions contained in the Solicitation, unless otherwise stated herein; that I am submitting this bid, offer or proposal for review and consideration; that I am authorized by the vendor to execute and submit this bid, offer, or proposal, or any documents related thereto on vendor's behalf; that I am authorized to bind the vendor in a contractual relationship; and that to the best of my knowledge, the vendor has properly registered with any State agency that may require registration.

SANY America, Inc.

(Company)

Thomas Schanz Jr. - Manager Municipal Sales

(Authorized Signature) (Representative Name, Title)

Thomas Schanz - Manager Municipal Sales

(Printed Name and Title of Authorized Representative)

4/14/21

(Date)

404-230-3728

(Phone Number) (Fax Number)

West Virginia Ethics Commission



Disclosure of Interested Parties to Contracts

Pursuant to *W. Va. Code* § 6D-1-2, a state agency may not enter into a contract, or a series of related contracts, that has/have an actual or estimated value of \$1 million or more until the business entity submits to the contracting state agency a Disclosure of Interested Parties to the applicable contract. In addition, the business entity awarded a contract is obligated to submit a supplemental Disclosure of Interested Parties reflecting any new or differing interested parties to the contract within 30 days following the completion or termination of the applicable contract.

For purposes of complying with these requirements, the following definitions apply:

"Business entity" means any entity recognized by law through which business is conducted, including a sole proprietorship, partnership or corporation, but does not include publicly traded companies listed on a national or international stock exchange.

"Interested party" or *"Interested parties"* means:

- (1) A business entity performing work or service pursuant to, or in furtherance of, the applicable contract, including specifically sub-contractors;
- (2) the person(s) who have an ownership interest equal to or greater than 25% in the business entity performing work or service pursuant to, or in furtherance of, the applicable contract. (This subdivision does not apply to a publicly traded company); and
- (3) the person or business entity, if any, that served as a compensated broker or intermediary to actively facilitate the applicable contract or negotiated the terms of the applicable contract with the state agency. (This subdivision does not apply to persons or business entities performing legal services related to the negotiation or drafting of the applicable contract.)

"State agency" means a board, commission, office, department or other agency in the executive, judicial or legislative branch of state government, including publicly funded institutions of higher education: Provided, that for purposes of *W. Va. Code* § 6D-1-2, the West Virginia Investment Management Board shall not be deemed a state agency nor subject to the requirements of that provision.

The contracting business entity must complete this form and submit it to the contracting state agency prior to contract award and to complete another form within 30 days of contract completion or termination.

This form was created by the State of West Virginia Ethics Commission, 210 Brooks Street, Suite 300, Charleston, WV 25301-1804. Telephone: (304)558-0664; fax: (304)558-2169; e-mail: ethics@wv.gov; website: www.ethics.wv.gov.

West Virginia Ethics Commission
Disclosure of Interested Parties to Contracts

(Required by *W. Va. Code* § 6D-1-2)

Name of Contracting Business Entity: SANY America, Inc. Address: 318 Cooper Circle
Peachtree City, GA 30269

Name of Authorized Agent: Tom Schanz Address: _____

Contract Number: _____ Contract Description: Motor Graders

Governmental agency awarding contract: WV DOH

Check here if this is a Supplemental Disclosure

List the Names of Interested Parties to the contract which are known or reasonably anticipated by the contracting business entity for each category below (*attach additional pages if necessary*):

1. Subcontractors or other entities performing work or service under the Contract

Check here if none, otherwise list entity/individual names below.

2. Any person or entity who owns 25% or more of contracting entity (not applicable to publicly traded entities)

Check here if none, otherwise list entity/individual names below.

3. Any person or entity that facilitated, or negotiated the terms of, the applicable contract (excluding legal services related to the negotiation or drafting of the applicable contract)

Check here if none, otherwise list entity/individual names below.

Signature: 

Date Signed: 4/14/21

Notary Verification

State of Georgia, County of Fayette:

I, Thomas P Schanz Jr, the authorized agent of the contracting business entity listed above, being duly sworn, acknowledge that the Disclosure herein is being made under oath and under the penalty of perjury.

Taken, sworn to and subscribed before me this 14 day of April, 2021.

Notary Public's Signature

To be completed by State Agency:

Date Received by State Agency: _____

Date submitted to Ethics Commission: _____

Governmental agency submitting Disclosure: _____



Department of Administration
 Purchasing Division
 2019 Washington Street East
 Post Office Box 50130
 Charleston, WV 25305-0130

State of West Virginia
 Centralized Request for Quote
 Equipment

Proc Folder: 846036			Reason for Modification:
Doc Description: Motor grader all wheel dr.w/reversible frt.mtd. trip plow			
Proc Type: Central Master Agreement			
Date Issued	Solicitation Closes	Solicitation No	Version
2021-03-08	2021-04-08 13:30	CRFQ 0803 DOT2100000108	1

BID RECEIVING LOCATION

BID CLERK
 DEPARTMENT OF ADMINISTRATION
 PURCHASING DIVISION
 2019 WASHINGTON ST E
 CHARLESTON WV 25305
 US

VENDOR

Vendor Customer Code:VS0000037852

Vendor Name :SANY America Inc

Address :318 Cooper Circle

Street :

City :Peachtree City

State :GA Country :USA Zip :30269

Principal Contact : Tom Schanz

Vendor Contact Phone:404-430-3728 Extension:

FOR INFORMATION CONTACT THE BUYER

John W Estep
 304-558-2566
 john.w.estep@wv.gov

Vendor Signature X  FEIN# 20-5048542 DATE 4/14/21

All offers subject to all terms and conditions contained in this solicitation

ADDITIONAL INFORMATION**REQUEST FOR QUOTATION:**

The West Virginia Purchasing Division is soliciting bids on behalf of West Virginia Division of Highways to establish an open-end contract for a Motor Grader Articulated All Wheel Drive w/ Reversible Front Mounted Trip/Plow John Deere 672 AWD or equal. Per the bid requirements, specifications, terms and conditions attached to this solicitation.

INVOICE TO	SHIP TO
DIVISION OF HIGHWAYS EQUIPMENT DIVISION RT 33 83 BRUSHY ROAD CROSSING, PO BOX 610 BUCKHANNON WV 26201 US	DIVISION OF HIGHWAYS EQUIPMENT DIVISION 83 BRUSHY FORK RD CROSSING BUCKHANNON WV 26201 US

Line	Comm Ln Desc	Qty	Unit Issue	Unit Price	Total Price
1	Motor grader articulated all wheel drive	10.00000	EA		

Comm Code	Manufacturer	Specification	Model #
22101502			

Extended Description:

Motor grader articulated all wheel drive w/reversible front mounted trip/plow

SCHEDULE OF EVENTS

<u>Line</u>	<u>Event</u>	<u>Event Date</u>
1	Pre-Bid Meeting at 12:00pm @ Buckhannon	2021-03-24
2	Tech Questions due by 10:00am	2021-04-01

	Document Phase	Document Description	Page
DOT2100000108	Final	Motor grader all wheel dr.w/ reversible frt.mtd. trip plow	3

ADDITIONAL TERMS AND CONDITIONS

See attached document(s) for additional Terms and Conditions



Department of Administration
 Purchasing Division
 2019 Washington Street East
 Post Office Box 50130
 Charleston, WV 25305-0130

State of West Virginia
 Centralized Request for Quote
 Equipment

Proc Folder: 846036		Reason for Modification:	
Doc Description: ADDENDUM NO_1 Motor grader all wheel dr.		ADDENDUM NO_1 Attach Pre-Bid Sign in Sheets	
Proc Type: Central Master Agreement			
Date Issued	Solicitation Closes	Solicitation No	Version
2021-03-25	2021-04-08 13:30	CRFQ 0803 DOT2100000108	2

BID RECEIVING LOCATION

BID CLERK
 DEPARTMENT OF ADMINISTRATION
 PURCHASING DIVISION
 2019 WASHINGTON ST E
 CHARLESTON WV 25305
 US

VENDOR

Vendor Customer Code:VS0000037852

Vendor Name : Address :SANY America Inc

Street :318 Cooper Circle

City :Peachtree City

State :GA

Principal Contact : Tom Schanz Country : USA Zip :30269

Vendor Contact Phone: 404-230-3728

Extension:

FOR INFORMATION CONTACT THE BUYER

John W Estep
 304-558-2566
 john.w.estep@wv.gov

Vendor Signature X  FEIN# 20-5048542 DATE 4/14/21

All offers subject to all terms and conditions contained in this solicitation

ADDITIONAL INFORMATION

ADDENDUM NO_1

Addendum No_1 issued to publish and distribute the attached information to the vendor Community

REQUEST FOR QUOTATION:

The West Virginia Purchasing Division is soliciting bids on behalf of West Virginia Division of Highways to establish an open-end contract for a Motor Grader Articulated All Wheel Drive w/ Reversible Front Mounted Trip/Plow John Deere 672 AWD or equal. Per the bid requirements, specifications, terms and conditions attached to this solicitation.

INVOICE TO	SHIP TO
DIVISION OF HIGHWAYS EQUIPMENT DIVISION RT 33 83 BRUSHY ROAD CROSSING, PO BOX 610 BUCKHANNON WV 26201 US	DIVISION OF HIGHWAYS EQUIPMENT DIVISION 83 BRUSHY FORK RD CROSSING BUCKHANNON WV 26201 US

Line	Comm Ln Desc	Qty	Unit Issue	Unit Price	Total Price
1	Motor grader articulated all wheel drive	10.00000	EA		

Comm Code	Manufacturer	Specification	Model #
22101502			

Extended Description:

Motor grader articulated all wheel drive w/reversible front mounted trip/plow

SCHEDULE OF EVENTS

<u>Line</u>	<u>Event</u>	<u>Event Date</u>
1	Pre-Bid Meeting at 12:00pm @ Buckhannon	2021-03-24
2	Tech Questions due by 10:00am	2021-04-01

	Document Phase	Document Description	Page
DOT2100000108	Final	ADDENDUM NO_1 Motor grader all wheel dr.	3

ADDITIONAL TERMS AND CONDITIONS

See attached document(s) for additional Terms and Conditions



Department of Administration
 Purchasing Division
 2019 Washington Street East
 Post Office Box 50130
 Charleston, WV 25305-0130

State of West Virginia
 Centralized Request for Quote
 Equipment

Proc Folder: 846036		Reason for Modification:	
Doc Description: ADDENDUM NO_2 Motor grader all wheel dr.		ADDENDUM NO_2 To move bid opening Bid Opening moves to 04/14/21	
Proc Type: Central Master Agreement			
Date Issued	Solicitation Closes	Solicitation No	Version
2021-04-01	2021-04-14 13:30	CRFQ 0803 DOT2100000108	3

BID RECEIVING LOCATION

BID CLERK
 DEPARTMENT OF ADMINISTRATION
 PURCHASING DIVISION
 2019 WASHINGTON ST E
 CHARLESTON WV 25305
 US

VENDOR

Vendor Customer Code: VS0000037852

Vendor Name : SANY America Inc

Address :318 Cooper Circle

Street :

City :Peachtree City

State :GA Country :USA Zip :30269

Principal Contact : Tom Schanz

Vendor Contact Phone:404-230-3728 Extension:

FOR INFORMATION CONTACT THE BUYER

John W Estep
 304-558-2566
 john.w.estep@wv.gov

Vendor Signature X  FEIN#20-5048542 DATE4/14/21

All offers subject to all terms and conditions contained in this solicitation

	Document Phase	Document Description	Page
DOT2100000108	Final	ADDENDUM NO_2 Motor grader all wheel dr.	3

ADDITIONAL TERMS AND CONDITIONS

See attached document(s) for additional Terms and Conditions



Department of Administration
 Purchasing Division
 2019 Washington Street East
 Post Office Box 50130
 Charleston, WV 25305-0130

State of West Virginia
 Centralized Request for Quote
 Equipment

Proc Folder: 846036		Reason for Modification:	
Doc Description: ADDENDUM NO_3 Motor grader all wheel dr.		ADDENDUM NO_3	
Proc Type: Central Master Agreement		Addendum No_3 - to attach Vendor Questions and Responses	
Date Issued	Solicitation Closes	Solicitation No	Version
2021-04-06	2021-04-14 13:30	CRFQ 0803 DOT2100000108	4

BID RECEIVING LOCATION

BID CLERK
 DEPARTMENT OF ADMINISTRATION
 PURCHASING DIVISION
 2019 WASHINGTON ST E
 CHARLESTON WV 25305
 US

VENDOR

Vendor Customer Code:VS0000037852

Vendor Name : SANY America Inc

Address : 318 Cooper Circle

Street :

City :Peachtree City

State : GA Country :USA Zip :30269

Principal Contact : Tom Schanz

Vendor Contact Phone:404-230-3728 Extension:

FOR INFORMATION CONTACT THE BUYER

John W Estep
 304-558-2566
 john.w.estep@wv.gov

Vendor Signature X  FEIN# 20-5048542 DATE 4/14/21

All offers subject to all terms and conditions contained in this solicitation

ADDITIONAL INFORMATION

ADDENDUM NO_3

Addendum No_3 issued to publish and distribute the attached information to the vendor Community

REQUEST FOR QUOTATION:

The West Virginia Purchasing Division is soliciting bids on behalf of West Virginia Division of Highways to establish an open-end contract for a Motor Grader Articulated All Wheel Drive w/ Reversible Front Mounted Trip/Plow John Deere 672 AWD or equal. Per the bid requirements, specifications, terms and conditions attached to this solicitation.

INVOICE TO	SHIP TO
DIVISION OF HIGHWAYS EQUIPMENT DIVISION RT 33 83 BRUSHY ROAD CROSSING, PO BOX 610 BUCKHANNON WV 26201 US	DIVISION OF HIGHWAYS EQUIPMENT DIVISION 83 BRUSHY FORK RD CROSSING BUCKHANNON WV 26201 US

Line	Comm Ln Desc	Qty	Unit Issue	Unit Price	Total Price
1	Motor grader articulated all wheel drive	10.00000	EA		

Comm Code	Manufacturer	Specification	Model #
22101502			

Extended Description:

Motor grader articulated all wheel drive w/reversible front mounted trip/plow

SCHEDULE OF EVENTS

<u>Line</u>	<u>Event</u>	<u>Event Date</u>
1	Pre-Bid Meeting at 12:00pm @ Buckhannon	2021-03-24
2	Tech Questions due by 10:00am	2021-04-01

	Document Phase	Document Description	Page
DOT2100000108	Final	ADDENDUM NO_3 Motor grader all wheel dr.	3

ADDITIONAL TERMS AND CONDITIONS

See attached document(s) for additional Terms and Conditions



Department of Administration
 Purchasing Division
 2019 Washington Street East
 Post Office Box 50130
 Charleston, WV 25305-0130

State of West Virginia
 Centralized Request for Quote
 Equipment

Proc Folder: 846036		Reason for Modification:	
Doc Description: ADDENDUM NO_4 Motor grader all wheel dr.		ADDENDUM NO_4 VENDOR QUESTIONS AND RESPONSES	
Proc Type: Central Master Agreement			
Date Issued	Solicitation Closes	Solicitation No	Version
2021-04-12	2021-04-14 13:30	CRFQ 0803 DOT2100000108	5

BID RECEIVING LOCATION

BID CLERK
 DEPARTMENT OF ADMINISTRATION
 PURCHASING DIVISION
 2019 WASHINGTON ST E
 CHARLESTON WV 25305
 US

VENDOR

Vendor Customer Code: VS0000037852

Vendor Name : SANY America Inc

Address :318 Cooper Circle

Street :

City :Peachtree City

State :GA Country : USA Zip : 30269

Principal Contact : Tom Schanz

Vendor Contact Phone: 404-230-3728 Extension:

FOR INFORMATION CONTACT THE BUYER

John W Estep
 304-558-2566
 john.w.estep@wv.gov

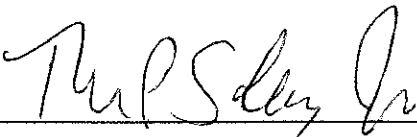
Vendor
 Signature X  FEIN# 20-5048542 DATE 4/14/21

All offers subject to all terms and conditions contained in this solicitation

ADDITIONAL INFORMATION

ADDENDUM NO_4

Addendum No_4 issued to publish and distribute the attached information to the vendor Community

REQUEST FOR QUOTATION:

The West Virginia Purchasing Division is soliciting bids on behalf of West Virginia Division of Highways to establish an open-end contract for a Motor Grader Articulated All Wheel Drive w/ Reversible Front Mounted Trip/Plow John Deere 672 AWD or equal. Per the bid requirements, specifications, terms and conditions attached to this solicitation.

INVOICE TO		SHIP TO	
DIVISION OF HIGHWAYS EQUIPMENT DIVISION RT 33 83 BRUSHY ROAD CROSSING, PO BOX 610 BUCKHANNON WV US		DIVISION OF HIGHWAYS EQUIPMENT DIVISION 83 BRUSHY FORK RD CROSSING BUCKHANNON WV US	

Line	Comm Ln Desc	Qty	Unit Issue	Unit Price	Total Price
1	Motor grader articulated all wheel drive	10.00000	EA		

Comm Code	Manufacturer	Specification	Model #
22101502			

Extended Description:

Motor grader articulated all wheel drive w/reversible front mounted trip/plow

SCHEDULE OF EVENTS

Line	Event	Event Date
1	Pre-Bid Meeting at 12:00pm @ Buckhannon	2021-03-24
2	Tech Questions due by 10:00am	2021-04-01

	Document Phase	Document Description	Page
DOT2100000108	Final	ADDENDUM NO_4 Motor grader all wheel dr.	3

ADDITIONAL TERMS AND CONDITIONS

See attached document(s) for additional Terms and Conditions

STATE OF WEST VIRGINIA
Purchasing Division

PURCHASING AFFIDAVIT

CONSTRUCTION CONTRACTS: Under W. Va. Code § 5-22-1(j), the contracting public entity shall not award a construction contract to any bidder that is known to be in default on any monetary obligation owed to the state or a political subdivision of the state, including, but not limited to, obligations related to payroll taxes, property taxes, sales and use taxes, fire service fees, or other fines or fees.

ALL CONTRACTS: Under W. Va. Code §5A-3-10a, no contract or renewal of any contract may be awarded by the state or any of its political subdivisions to any vendor or prospective vendor when the vendor or prospective vendor or a related party to the vendor or prospective vendor is a debtor and: (1) the debt owed is an amount greater than one thousand dollars in the aggregate; or (2) the debtor is in employer default.

EXCEPTION: The prohibition listed above does not apply where a vendor has contested any tax administered pursuant to chapter eleven of the W. Va. Code, workers' compensation premium, permit fee or environmental fee or assessment and the matter has not become final or where the vendor has entered into a payment plan or agreement and the vendor is not in default of any of the provisions of such plan or agreement.

DEFINITIONS:

"Debt" means any assessment, premium, penalty, fine, tax or other amount of money owed to the state or any of its political subdivisions because of a judgment, fine, permit violation, license assessment, defaulted workers' compensation premium, penalty or other assessment presently delinquent or due and required to be paid to the state or any of its political subdivisions, including any interest or additional penalties accrued thereon.

"Employer default" means having an outstanding balance or liability to the old fund or to the uninsured employers' fund or being in policy default, as defined in W. Va. Code § 23-2c-2, failure to maintain mandatory workers' compensation coverage, or failure to fully meet its obligations as a workers' compensation self-insured employer. An employer is not in employer default if it has entered into a repayment agreement with the Insurance Commissioner and remains in compliance with the obligations under the repayment agreement.

"Related party" means a party, whether an individual, corporation, partnership, association, limited liability company or any other form or business association or other entity whatsoever, related to any vendor by blood, marriage, ownership or contract through which the party has a relationship of ownership or other interest with the vendor so that the party will actually or by effect receive or control a portion of the benefit, profit or other consideration from performance of a vendor contract with the party receiving an amount that meets or exceeds five percent of the total contract amount.

AFFIRMATION: By signing this form, the vendor's authorized signer affirms and acknowledges under penalty of law for false swearing (*W. Va. Code §61-5-3*) that: (1) for construction contracts, the vendor is not in default on any monetary obligation owed to the state or a political subdivision of the state, and (2) for all other contracts, that neither vendor nor any related party owe a debt as defined above and that neither vendor nor any related party are in employer default as defined above, unless the debt or employer default is permitted under the exception above.

WITNESS THE FOLLOWING SIGNATURE:

Vendor's Name: _____

Authorized Signature: _____ Date: _____

State of _____

County of _____, to-wit:

Taken, subscribed, and sworn to before me this ____ day of _____, 20__.

My Commission expires _____, 20__.

AFFIX SEAL HERE

NOTARY PUBLIC _____

SMG200C-8

PRODUCT SPECIFICATIONS



STANDARD FEATURES

- 14-foot blade to quickly handle even large jobs
 - Joystick controls for grading and steering wheel for roading offer simple-to-learn operation
 - Air-conditioned cab and heated air ride seat standard for operator comfort
 - Open cab design with rear-view camera maximizes line of sight and visibility
- ➔ **Engine Output - Net**
186 kW / 253 hp
 - ➔ **Operating Weight**
20 760 kg / 45,768 lb
 - ➔ **Moldboard Width**
4 270 mm / 14 ft

PRODUCT SPECIFICATIONS

MODEL: **SMG200C-8** Motor Grader

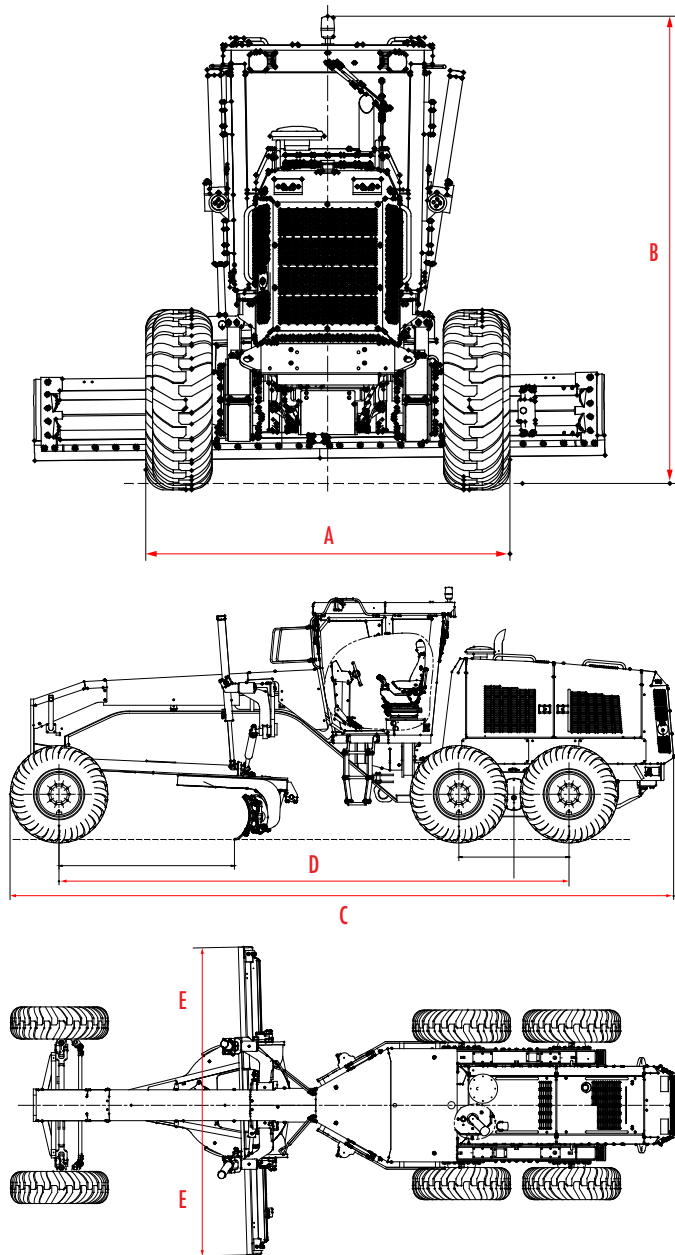

OVERALL DIMENSIONS

	METRIC	STANDARD
A Width Over Std Tires	2 725 mm	107.28"
B Height Over ROPS	3 498 mm	137.72"
C Overall Length	9 187 mm	361.69"
D Wheelbase (F/R)	6 300 mm	248.03"
E Width - Moldboard	4 270 mm	14'

In the interest of continual equipment development, SANY America, Inc. reserves the right to change these specifications at any time without prior notification.

Machine Parameters

Engine

Engine Model	Cummins QSL9-C250	
Engine Net Power	186 kW	253 hp
Torque Rated Speed	1,500 rpm	
Displacement	8.9 L	543.1 in ³
Turbo Charged with Intercooler	Yes	

Operating

Frame Type	Articulated	
Moldboard	4 270 mm	14 ft
Moldboard - Cutting Depth	715 mm	28.15 in
Moldboard Height	620 mm	24.41 in
Moldboard - Lift Above Ground	480 mm	18.9 in
Frame Articulation	22°	
Front Wheel Lean	17°	
Axle Oscillation	16°	
Turning Radius - Minimum	7.5 m	295.28 in
Transport Width	2 725 mm	107.28 in
Fuel Tank	340 L	89.82 gal
Telematics Available	Yes	

Powertrain

Drive Configuration	6 x 4	
Traction Aid	Manual Differential Lock	
Service Brake Type	Wet Multiple-Disc	
Number of Axles	2	
Tire Size - Standard	17.5-25	

Transmission

Transmission Type	Direct-Drive, Power Shift	
Number of Speeds	8-Forward	

Weight

Operating Weight	20 460 kg	45,107 lb
Operating Weight - Maximum	20 760 kg	45,768 lb
Loading - Rear Axle / Tandem	15 335 kg	33,808 lb
Blade Down Pressure	9 038 kgf	19,925 lbf

SANY America, Inc.

318 Cooper Circle • Peachtree City, GA 30269 • T: 470-552-SANY • sanyamerica.com



©2020 SANY America, Inc.