



Department of Administration
 Purchasing Division
 2019 Washington Street East
 Post Office Box 50130
 Charleston, WV 25305-0130

State of West Virginia
 Centralized Request for Quote
 Construction

RECEIVED
 03/25/21 11:10:24
 WV PURCHASING DIVISION

Proc Folder: 814205		Reason for Modification:	
Doc Description: ADDENDUM NO.2 ROOFING SYSTEM		ADDENDUM NO.2 To attach Vendor Questions and responses	
Proc Type: Central Purchase Order			
Date Issued	Solicitation Closes	Solicitation No	Version
2021-03-11	2021-03-25 13:30	CRFQ 0803 DOT2100000098	3

BID RECEIVING LOCATION

BID CLERK
 DEPARTMENT OF ADMINISTRATION
 PURCHASING DIVISION
 2019 WASHINGTON ST E
 CHARLESTON WV 25305
 US

VENDOR

Vendor Customer Code:

Vendor Name :

Address : R & T ENTERPRISES, INC.
 P.O. BOX 727
Street : BRIDGEPORT, WV 26330
City : 304-623-4827

State : **Country :** **Zip :**

Principal Contact : Nathaniel G. Rohrig

Vendor Contact Phone: 304-623-4827 **Extension:**

FOR INFORMATION CONTACT THE BUYER
 John W Estep
 304-558-2566
 john.w.estep@wv.gov

Vendor Signature X  **FEIN#** 55-057-4291 **DATE** 3-24-2021

All offers subject to all terms and conditions contained in this solicitation

ADDITIONAL INFORMATION

ADDENDUM NO_2

Addendum No.2 issued to publish and distribute the attached information to the Vendor Community.

REQUEST FOR QUOTATION:

The West Virginia Purchasing Division is soliciting bids on behalf of West Virginia Division of Highways (WVDOH) to establish a contract for the following:

Installation of a roof system for the Sugar Grove Salt Shed in Pendleton County, West Virginia. The roof system would be designed and installed to consist of a single span truss arch, fabric covered, steel framed building roof system, to clear span the 42 ft. OD x 32 ft. OD structure, as per the attached Project Plans and documents.

The Vendor shall furnish all materials, labor, and equipment necessary to complete all Construction Services. The Vendor shall furnish any incidental work, materials, labor, and equipment that are necessary to complete the Construction Services, even if such incidental work is not explicitly included in the Project Plans.

Per the Bid Requirements, Specifications, Terms and Conditions attached to this Solicitation.

INVOICE TO	SHIP TO
DIVISION OF HIGHWAYS DISTRICT EIGHT - ALL LOCATIONS PO BOX 1516 ELKINS WV 26241 US	WV DIVISION OF HIGHWAYS SUGAR GROVE SUBSTATION 9315 SUGAR GROVE RD SUGAR GROVE WV 26815 US

Line	Comm Ln Desc	Qty	Unit Issue	Unit Price	Total Price
1	Roofing System	1.00000	EA		48,766.68

Comm Code	Manufacturer	Specification	Model #
25174100	Brite span		Atlas

Extended Description:

32' x 42' Roofing System for the Sugar Grove Salt Shed

SCHEDULE OF EVENTS

Line	Event	Event Date
1	Mandatory Pre-bid 11:00am	2021-03-09
2	Tech Questions due by : 10:00am	2021-03-16

SOLICITATION NUMBER: CRFQ DOT2100000098

Addendum Number: 2

The purpose of this addendum is to modify the solicitation identified as CRFQ DOT2100000098 ("Solicitation") to reflect the change(s) identified and described below.

Applicable Addendum Category:

- Modify bid opening date and time
- Modify specifications of product or service being sought
- Attachment of vendor questions and responses
- Attachment of pre-bid sign-in sheet
- Correction of error
- Other

Additional Documentation:

1. Attach Vendor Questions and responses

Bid Opening remains 03/25/21 at 1:30pm

Terms and Conditions:

1. All provisions of the Solicitation and other addenda not modified herein shall remain in full force and effect.
2. Vendor should acknowledge receipt of all addenda issued for this Solicitation by completing an Addendum Acknowledgment, a copy of which is included herewith. Failure to acknowledge addenda may result in bid disqualification. The addendum acknowledgement should be submitted with the bid to expedite document processing.

**CRFQ DOT 21*98
Vendor Questions – Responses**

Question: Can a fabric roll-up door be used as an alternative?

Answer: A fabric roll-up door will be accepted.

Question: Can a 220 fabric termination be used instead of a 320 termination?

Per the attachment, a "220 fabric termination" will be accepted if all metallic materials are galvanized in accordance with the contract documents at III. Steel Frame Requirements, Section E. (See Attached)

Question: Who is responsible for the 36" fan?

Answer: Per the contract documents at III. Steel Frame Requirements, Section K.: "The 36"x36" exhaust fan will be supplied and installed and tested in place by the contractor and it will be suitable for use in the corrosive salt shed environment and will be incidental to the Roof System Line Item no. 1 bid price. WVDOT will complete the electrical connections necessary for the permanent exhaust fan operation."

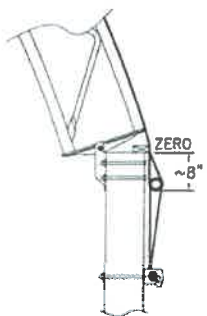

**INCLUSIVE
POCKET**

(220 fabric - std 8" drop below zero)

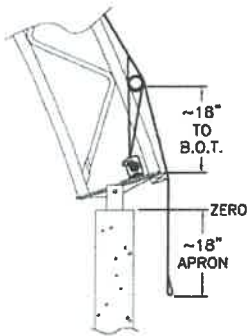

**INTERIOR
TENSION POCKET**

(320 fabric - std 18" drop below zero)

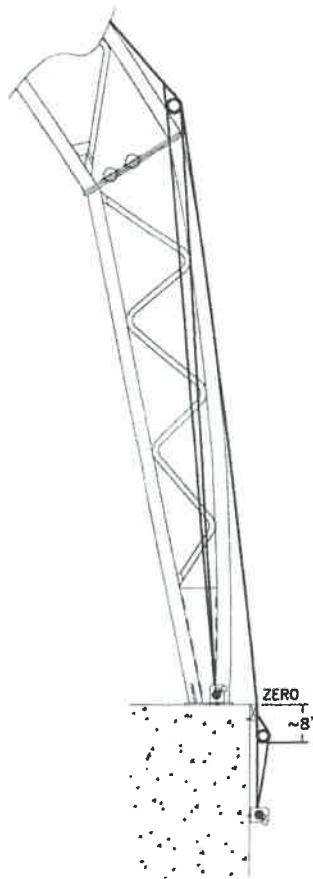

**UPPER INTERIOR
TENSION POCKET
w/ INCLUSIVE
POCKET**

(420 fabric - std 8" drop
below zero)

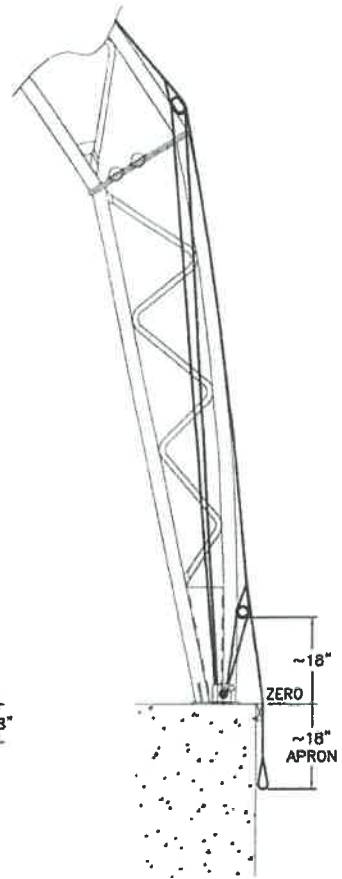

**DUAL INTERIOR
TENSION POCKETS**

(420 fabric - std 18" drop
below zero)

ADDENDUM ACKNOWLEDGEMENT FORM
SOLICITATION NO.: CRFO DOT2100000098

Instructions: Please acknowledge receipt of all addenda issued with this solicitation by completing this addendum acknowledgment form. Check the box next to each addendum received and sign below. Failure to acknowledge addenda may result in bid disqualification.

Acknowledgment: I hereby acknowledge receipt of the following addenda and have made the necessary revisions to my proposal, plans and/or specification, etc.

Addendum Numbers Received:

(Check the box next to each addendum received)

- | | |
|--|--|
| <input type="checkbox"/> Addendum No. 1 | <input type="checkbox"/> Addendum No. 6 |
| <input checked="" type="checkbox"/> Addendum No. 2 | <input type="checkbox"/> Addendum No. 7 |
| <input type="checkbox"/> Addendum No. 3 | <input type="checkbox"/> Addendum No. 8 |
| <input type="checkbox"/> Addendum No. 4 | <input type="checkbox"/> Addendum No. 9 |
| <input type="checkbox"/> Addendum No. 5 | <input type="checkbox"/> Addendum No. 10 |

I understand that failure to confirm the receipt of addenda may be cause for rejection of this bid. I further understand that that any verbal representation made or assumed to be made during any oral discussion held between Vendor's representatives and any state personnel is not binding. Only the information issued in writing and added to the specifications by an official addendum is binding.

R+E Enterprises, Inc.
Company

Authorized Signature

3-24-2021
Date

NOTE: This addendum acknowledgement should be submitted with the bid to expedite document processing.

REQUEST FOR QUOTATION

Pendleton County, Sugar Grove,
Salt Shed Building Roof System

GENERAL CONSTRUCTION SPECIFICATIONS (No AIA Documents)

- 1. PURPOSE AND SCOPE:** The West Virginia Purchasing Division is soliciting bids on behalf of West Virginia Division of Highways (WVDOH) to establish a contract for the following: Installation of a roof system for the Sugar Grove Salt Shed in Pendleton County, West Virginia. The roof system would be designed and installed to consist of a single span truss arch, fabric covered, steel framed building roof system, to clear span the 42 ft. OD x 32 ft. OD structure, as per the attached Project Plans and documents.

The Vendor shall furnish all materials, labor, and equipment necessary to complete all Construction Services. The Vendor shall furnish any incidental work, materials, labor, and equipment that are necessary to complete the Construction Services, even if such incidental work is not explicitly included in the Project Plans.

- 2. DEFINITIONS:** The terms listed below shall have the meanings assigned to them below. Additional definitions can be found in section 2 of the General Terms and Conditions and in the Project Plans as defined below.

2.1 "Construction Services" means design and installation of any and all aspects of the building roof system, as more fully described in the Project Plans.

2.2 "Pricing Page" means the pages contained in WVOASIS, attached hereto as Exhibit A, or included in the Project Plans upon which Vendor should list its proposed price for the Construction Services.

2.3 "Solicitation" means the official notice of an opportunity to supply the State with Construction Services that is published by the Purchasing Division.

2.4 "WVDOH" means the West Virginia Division of Highways.

2.5 "Roof System" means all components comprised in a single span truss arch fabric Covered steel framed building roof system which will be used to cover the Sugar Grove Salt Shed.

2.6 "ASCE" means the American Society of Civil Engineers. Reference: www.asce.org

2.7 "ANSI" means the American National Standards Institute. Reference: www.ansi.org.

2.8 "AISC" means the American Institute of Steel Construction. Reference: www.aisc.org.

2.9 "AASHTO" means the American Association of State Highway and Transportation Officials. Reference: www.astm.org.

2.10 "ASTM" means the American Society for Testing and Materials. Reference: www.astm.org.

REQUEST FOR QUOTATION

Pendleton County, Sugar Grove,
Salt Shed Building Roof System

2.11 "HSS" means Hollow Structural Steel.

2.12 "PSI" means Pounds per Square Inch.

2.13 "PSF" means per Square Foot.

2.14 "Contractor" or "Vendor" or "Bidder" used throughout this Solicitation and in any cited sections of the West Virginia Department of Transportation, Division of Highways Standard Specifications, Roads, and Bridges, most recent edition, as modified by all subsequent annual supplemental Specifications, are interchangeable.

2.15 "Project Plans" means documents developed by an architect, an engineer, the Agency, or another design professional, which are attached hereto as Exhibit B, that provide detailed instructions on how the Construction Services are to be performed. In the event that Project Plans contain drawings or other documents too large to attach in Exhibit B, Vendors can obtain copies in accordance with Section 9 of these Specifications.

- 3. ORDER OF PRECEDENCE:** This General Construction Specifications document will have priority over, and supersede, anything contained in the Project Plans.
- 4. QUALIFICATIONS:** Vendor, or Vendor's staff if requirements are inherently limited to individuals rather than corporate entities, shall have the following minimum qualifications:
 - 4.1. Experience:** Vendor, or Vendor's supervisory staff assigned to this project, must have successfully completed at least six projects that involved work similar to that described in these specifications or the Project Plans. Compliance with this experience requirement will be determined prior to contract award by the State through references provided by the Vendor upon request, through knowledge or documentation of the Vendor's past projects, through confirmation of experience requirements from the architect assisting the State in this project, or some other method that the State determines to be acceptable. Vendor must provide any documentation requested by the State to assist in confirmation of compliance with this provision. References, documentation, or other information to confirm compliance with this experience requirement may be requested after bid opening and prior to contract award.
- 5. CONTRACT AWARD:** The Contract is intended to provide Agency with a purchase price for the Construction Services. The Contract will be awarded to the lowest qualified responsible bidder meeting the required specifications. If the Pricing Pages contain alternates/add-ons, the Contract will be awarded based on the grand total of the base bid and any alternates/add-ons selected.
- 6. SELECTION OF ALTERNATES:** Pursuant to W. Va. Code § 5-22-1(f), any solicitation of bids shall include no more than five alternates. Alternates, if accepted, shall be accepted in the order in which they are listed on the bid form. Any unaccepted alternate contained within a bid

REQUEST FOR QUOTATION

Pendleton County, Sugar Grove,
Salt Shed Building Roof System

shall expire 90 days after the date of the opening of bids for review. Determination of the lowest qualified responsible bidder shall be based on the sum of the base bid and any alternates accepted.

7. **PERFORMANCE:** Vendor shall perform the Construction Services in accordance with this document and the Project Plans.
8. **SUBSTITUTIONS:** Any substitution requests must be submitted in accordance with the official question and answer period described in the INSTRUCTIONS TO VENDORS SUBMITTING BIDS, Paragraph 4. Vendor Question Deadline. Vendors submitting substitution requests should submit product brochures and product specifications during the official question and answer period.
9. **PROJECT PLANS:** The checked box will apply to Project Plans for this solicitation.
 - No Additional Project Plan Documents:** There are no additional Project Plans other than those attached hereto as Exhibit B or any subsequent addenda modifying Exhibit B.
 - Additional Project Plan Documents:** There are additional Project Plan documents other than those attached as Exhibit B. Copies of the additional Project Plan documents not attached as Exhibit B can be obtained by contacting the entity identified below.

Copies of project plans can be examined at the following locations

10. CONDITIONS OF THE WORK

- 10.1. **Permits:** The Vendor shall procure all necessary permits and licenses to comply with all applicable Federal, State, or Local laws, regulations and ordinances of any regulating body.
- 10.2. **Existing Conditions:** If discrepancies are discovered between the existing conditions and those noted in the specifications, Vendor must immediately notify the Agency's representative. Vendor must also immediately notify the Agency if suspected hazardous materials are encountered.
- 10.3. **Standard Work Hours:** The standard hours of work for this Contract will be Monday – Friday 7 AM – 5 PM excluding holidays recognized by the State of West Virginia. Any work outside of the standard hours of work must be approved in advance at the Agency's sole discretion. Authorization of work outside of the standard hours of work will not entitle Vendor to additional compensation.
- 10.4. **Project Closeout:** Project Closeout shall include the following:
 - 10.4.1. **Final Cleanup:** Vendor shall perform the final cleanup activities listed below, along with any other final cleanup activities normally associated with the work performed under this Contract, prior to final inspection:

REQUEST FOR QUOTATION

Pendleton County, Sugar Grove,
Salt Shed Building Roof System

10.4.1.1 Removal of all construction incidental materials from the project site
Is required.

10.4.1.2. Final Inspection: Vendor shall participate in a final inspection with the Agency's project manager. The purpose of the final inspection will be to identify deficiencies that need to be remedied prior to Agency's final acceptance of the work. Vendor shall at all times be obligated to perform in accordance with the Contract and must take all actions necessary to ensure that work complies with requirements of Contract prior to final acceptance. Final acceptance does not waive or release Vendor from its obligation to ensure that work complies with the Contract requirements. Vendor shall submit any warranty documents to the Agency project manager at final inspection.

11. FACILITIES ACCESS: Performance of Contract Services may require access cards and/or keys to gain entrance to Agency's facilities. In the event that access cards and/or keys are required:

11.1. Vendor must identify principal service personnel which will be issued access cards and/or keys to perform service.

11.2. Vendor will be responsible for controlling cards and keys and will pay replacement fee, if the cards or keys become lost or stolen.

11.3. Vendor shall notify Agency immediately of any lost, stolen, or missing card or key.

11.4. Anyone performing under this Contract will be subject to Agency's security protocol and procedures.

11.5. Vendor shall inform all staff of Agency's security protocol and procedures.

12. MISCELLANEOUS:

12.1. Contract Manager: During its performance of this Contract, Vendor must designate and maintain a primary contract manager responsible for overseeing Vendor's responsibilities under this Contract. The Contract manager must be available during normal business hours to address any customer service or other issues related to this Contract. Vendor should list its Contract manager and his or her contact information below.

Contract Manager: Nathaniel G. Rohrig

Telephone Number: 304-623-4827

Fax Number: 304-622-5546

Email Address: N.Rohrig@col.com

STATE OF WEST VIRGINIA
Purchasing Division

PURCHASING AFFIDAVIT

CONSTRUCTION CONTRACTS: Under W. Va. Code § 5-22-1(i), the contracting public entity shall not award a construction contract to any bidder that is known to be in default on any monetary obligation owed to the state or a political subdivision of the state, including, but not limited to, obligations related to payroll taxes, property taxes, sales and use taxes, fire service fees, or other fines or fees.

ALL CONTRACTS: Under W. Va. Code §5A-3-10a, no contract or renewal of any contract may be awarded by the state or any of its political subdivisions to any vendor or prospective vendor when the vendor or prospective vendor or a related party to the vendor or prospective vendor is a debtor and: (1) the debt owed is an amount greater than one thousand dollars in the aggregate; or (2) the debtor is in employer default.

EXCEPTION: The prohibition listed above does not apply where a vendor has contested any tax administered pursuant to chapter eleven of the W. Va. Code, workers' compensation premium, permit fee or environmental fee or assessment and the matter has not become final or where the vendor has entered into a payment plan or agreement and the vendor is not in default of any of the provisions of such plan or agreement.

DEFINITIONS:

"Debt" means any assessment, premium, penalty, fine, tax or other amount of money owed to the state or any of its political subdivisions because of a judgment, fine, permit violation, license assessment, defaulted workers' compensation premium, penalty or other assessment presently delinquent or due and required to be paid to the state or any of its political subdivisions, including any interest or additional penalties accrued thereon.

"Employer default" means having an outstanding balance or liability to the old fund or to the uninsured employers' fund or being in policy default, as defined in W. Va. Code § 23-2c-2, failure to maintain mandatory workers' compensation coverage, or failure to fully meet its obligations as a workers' compensation self-insured employer. An employer is not in employer default if it has entered into a repayment agreement with the Insurance Commissioner and remains in compliance with the obligations under the repayment agreement.

"Related party" means a party, whether an individual, corporation, partnership, association, limited liability company or any other form or business association or other entity whatsoever, related to any vendor by blood, marriage, ownership or contract through which the party has a relationship of ownership or other interest with the vendor so that the party will actually or by effect receive or control a portion of the benefit, profit or other consideration from performance of a vendor contract with the party receiving an amount that meets or exceeds five percent of the total contract amount.

AFFIRMATION: By signing this form, the vendor's authorized signer affirms and acknowledges under penalty of law for false swearing (W. Va. Code §61-5-3) that: (1) for construction contracts, the vendor is not in default on any monetary obligation owed to the state or a political subdivision of the state, and (2) for all other contracts, that neither vendor nor any related party owe a debt as defined above and that neither vendor nor any related party are in employer default as defined above, unless the debt or employer default is permitted under the exception above.

WITNESS THE FOLLOWING SIGNATURE:

Vendor's Name: R&T Enterprises, Inc

Authorized Signature: [Signature] Date: 3-23-2021

State of WV

County of Harrison, to-wit:

Taken, subscribed, and sworn to before me this 23 day of March, 2021.

My Commission expires November 17, 2025.

NOTARY PUBLIC [Signature]

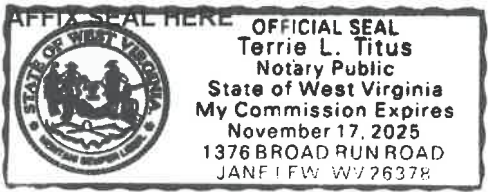

Q & A

Deadline

03/22/2021 03:00 PM EDT

Remarks

REQUEST FOR QUOTATION

Pendleton County, Sugar Grove,
Salt Shed Building Roof System

EXHIBIT A – Pricing Page

DATE: 3-24-2021

NAME OF VENDOR: R-T Enter Prices, Inc.

The aforementioned, hereinafter called Vendor, being familiar with and understanding the Bidding Documents and also having examined the sites and being familiar with all local conditions affecting the project hereby proposes to furnish all labor, material, equipment, supplies and transportation and to perform all Work in accordance with the Bidding Documents within the time set forth for the sum of:

TOTAL BID AMOUNT

For the sum of: Forty Eight Thousand Nine Hundred Sixty Six Dollars
and Sixty Eight Cents

(\$ 48,966.68)

(Show amount in both words and numbers)



Department of Administration
 Purchasing Division
 2019 Washington Street East
 Post Office Box 50130
 Charleston, WV 25305-0130

State of West Virginia
 Centralized Request for Quote
 Construction

Proc Folder: 814205 Doc Description: ROOFING SYSTEM Proc Type: Central Purchase Order			Reason for Modification:
Date Issued	Solicitation Closes	Solicitation No	
2021-02-23	2021-03-25 13:30	CRFQ 0803 DOT2100000098	1

BID RECEIVING LOCATION

BID CLERK
 DEPARTMENT OF ADMINISTRATION
 PURCHASING DIVISION
 2019 WASHINGTON ST E
 CHARLESTON WV 25305
 US

VENDOR

Vendor Customer Code:

Vendor Name : R & T ENTERPRISES, INC.
 P.O. BOX 727
 BRIDGEPORT, WV 26330
 304-623-4827

Address :

Street :

City :

State : **Country :** **Zip :**

Principal Contact : Nathaniel G. Roby

Vendor Contact Phone: 304-623-4827 **Extension:**

FOR INFORMATION CONTACT THE BUYER
 John W Estep
 304-558-2566
 john.w.estep@wv.gov

Vendor Signature X  **FEIN#** 55-057-4291 **DATE** 3-24-2021

All offers subject to all terms and conditions contained in this solicitation

ADDITIONAL INFORMATION**REQUEST FOR QUOTATION:**

The West Virginia Purchasing Division is soliciting bids on behalf of West Virginia Division of Highways (WVDOH) to establish a contract for the following:

Installation of a roof system for the Sugar Grove Salt Shed in Pendleton County, West Virginia. The roof system would be designed and installed to consist of a single span truss arch, fabric covered, steel framed building roof system, to clear span the 42 ft. OD x 32 ft. OD structure, as per the attached Project Plans and documents.

The Vendor shall furnish all materials, labor, and equipment necessary to complete all Construction Services. The Vendor shall furnish any incidental work, materials, labor, and equipment that are necessary to complete the Construction Services, even if such incidental work is not explicitly included in the Project Plans.

Per the Bid Requirements, Specifications, Terms and Conditions attached to this Solicitation.

INVOICE TO	SHIP TO
DIVISION OF HIGHWAYS DISTRICT EIGHT - ALL LOCATIONS PO BOX 1516 ELKINS WV 26241 US	WV DIVISION OF HIGHWAYS SUGAR GROVE SUBSTATION 9315 SUGAR GROVE RD SUGAR GROVE WV 26815 US

Line	Comm Ln Desc	Qty	Unit Issue	Unit Price	Total Price
1	Roofing System	1.00000	EA	48,966.68	

Comm Code	Manufacturer	Specification	Model #
25174100	Brite span		Atlas

Extended Description:

32' x 42' Roofing System for the Sugar Grove Salt Shed

SCHEDULE OF EVENTS

Line	Event	Event Date
1	Mandatory Pre-bid 11:00am	2021-03-09
2	Tech Questions due by : 10:00am	2021-03-16

	Document Phase	Document Description	Page
DOT2100000098	Final	ROOFING SYSTEM	3

ADDITIONAL TERMS AND CONDITIONS

- See attached document(s) for additional Terms and Conditions



Department of Administration
 Purchasing Division
 2019 Washington Street East
 Post Office Box 50130
 Charleston, WV 25305-0130

State of West Virginia
 Centralized Request for Quote
 Construction

Proc Folder: 814205			Reason for Modification: ADDENDUM NO.1 - To attached Pre-bid Sign-in sheets
Doc Description: ADDENDUM NO.1 ROOFING SYSTEM			
Proc Type: Central Purchase Order			
Date issued	Solicitation Closes	Solicitation No	Version
2021-03-11	2021-03-25 13:30	CRFQ 0803 DOT2100000098	2

BID RECEIVING LOCATION

BID CLERK
 DEPARTMENT OF ADMINISTRATION
 PURCHASING DIVISION
 2019 WASHINGTON ST E
 CHARLESTON WV 25305
 US

VENDOR

Vendor Customer Code:

Vendor Name :

Address : R & T ENTERPRISES, INC.
 P.O. BOX 727
Street : BRIDGEPORT, WV 26330
 304-623-4827
City :
State : **Country :** **Zip :**

Principal Contact : Nathaniel G. Rohrig
Vendor Contact Phone: 304-623-4827 **Extension:**

FOR INFORMATION CONTACT THE BUYER
 John W Estep
 304-558-2566
 john.w.estep@wv.gov

Vendor Signature X  **FEIN#** 55-057-4291 **DATE** 3-24-2021

ADDITIONAL INFORMATION

ADDENDUM NO_1

Addendum No.1 issued to publish and distribute the attached information to the Vendor Community.

REQUEST FOR QUOTATION:

The West Virginia Purchasing Division is soliciting bids on behalf of West Virginia Division of Highways (WVDOH) to establish a contract for the following:
 Installation of a roof system for the Sugar Grove Salt Shed in Pendleton County, West Virginia. The roof system would be designed and installed to consist of a single span truss arch, fabric covered, steel framed building roof system, to clear span the 42 ft. OD x 32 ft. OD structure, as per the attached Project Plans and documents.
 The Vendor shall furnish all materials, labor, and equipment necessary to complete all Construction Services. The Vendor shall furnish any incidental work, materials, labor, and equipment that are necessary to complete the Construction Services, even if such incidental work is not explicitly included in the Project Plans.
 Per the Bid Requirements, Specifications, Terms and Conditions attached to this Solicitation.

INVOICE TO	SHIP TO
DIVISION OF HIGHWAYS DISTRICT EIGHT - ALL LOCATIONS PO BOX 1516 ELKINS WV 26241 US	WV DIVISION OF HIGHWAYS SUGAR GROVE SUBSTATION 9315 SUGAR GROVE RD SUGAR GROVE WV 26815 US

Line	Comm Ln Desc	Qty	Unit Issue	Unit Price	Total Price
1	Roofing System	1.00000	EA	48,966.68	

Comm Code	Manufacturer	Specification	Model #
25174100	Brickspan		Atlas

Extended Description:

32' x 42' Roofing System for the Sugar Grove Salt Shed

SCHEDULE OF EVENTS

Line	Event	Event Date
1	Mandatory Pre-bid 11:00am	2021-03-09
2	Tech Questions due by : 10:00am	2021-03-16

SOLICITATION NUMBER: CRFQ DOT2100000098

Addendum Number: 1

The purpose of this addendum is to modify the solicitation identified as CRFQ DOT2100000098 (“Solicitation”) to reflect the change(s) identified and described below.

Applicable Addendum Category:

- Modify bid opening date and time
- Modify specifications of product or service being sought
- Attachment of vendor questions and responses
- Attachment of pre-bid sign-in sheet
- Correction of error
- Other

Additional Documentation:

1. Attach Pre-bid sign-in Sheet

Bid Opening remains 03/25/21 at 1:30pm

Terms and Conditions:

1. All provisions of the Solicitation and other addenda not modified herein shall remain in full force and effect.
2. Vendor should acknowledge receipt of all addenda issued for this Solicitation by completing an Addendum Acknowledgment, a copy of which is included herewith. Failure to acknowledge addenda may result in bid disqualification. The addendum acknowledgement should be submitted with the bid to expedite document processing.

Pre-Bid Sign-In Sheet

Solicitation Number: CRFQ DOT2100000098

Date of Pre-Bid Meeting: 03/09/2021

Location of Prebid Meeting: WV DDH-9315 Sugar Grove Road, Sugar Grove, WV 26815

Please Note:

Vendors must sign-in on this sheet to verify attendance at the Pre-Bid meeting. Failure to legibly sign in may be grounds for declaring a vendor ineligible to bid. For further verification, please also provide a business card if possible.

Firm Represented:*	Rep Name (Printed):	Firm Address:	Telephone #:	Fax #:	Email:
WV DOT Procurement	Kristy James	1900 Kanawha Blvd E Building 5, Rm A322 Charleston, WV	304-914-7104		kristy.e.james@wv.gov
K. Entapass	Diane Davis	PO Box 727 Berghart WV 26550	304-623-8227		WReising@aol.com
Shield Roofing	Tyler Kirkpatrick	3174 Earl I Cure Rd Morgantown, WV 26508	304-690-0319		tkirkpatrick@shieldroofing.biz
WUDCH DE	JEREMIAH KNAVENSHIRE	PO 1516 ELKENS, WV 26241	304-630-6075		Jeremiah.K.Knavenshires@wv.gov
WUDCH DE	Mary LEWIS	PO Box 1516 Elkins, WV 26241	304-637-0226		Mary-e.kwis@wv.gov

*One Vendor Per Representative - No one individual is permitted to represent more than one vendor at the pre-bid meeting. Any individual that does attempt to represent two or more vendors will be required to select one vendor to which the individual's attendance will be attributed. The vendors not selected will be deemed to have not attended the pre-bid meeting unless another individual attended on their behalf.

Pre-Bid Sign-In Sheet

Solicitation Number: CRFQ DOT2100000098

Date of Pre-Bid Meeting: 03/09/2021

Location of Prebid Meeting: WV DOH 9315 Sugar Grove Road, Sugar Grove, WV 26815

Please Note:

Vendors must sign-in on this sheet to verify attendance at the Pre-Bid meeting. Failure to legibly sign in may be grounds for declaring a vendor ineligible to bid. For further verification, please also provide a business card if possible.

Firm Represented:*	Rep Name (Printed):	Firm Address:	Telephone #:	Fax #:	Email:
WV DOH	MATT CANNON	1101 N. RANDOLPH AVE ELKINS, WV 26241	304-642-0449		Matthew.J.Cannon@WV.GOV
WV DOH	DYLAN STOUT	FRANKLIN WV 26807	304-358-2215		Dylan@stoutwv.com

**One Vendor Per Representative - No one individual is permitted to represent more than one vendor at the pre-bid meeting. Any individual that does attempt to represent two or more vendors will be required to select one vendor to which the individual's attendance will be attributed. The vendors not selected will be deemed to have not attended the pre-bid meeting unless another individual attended on their behalf.*

ADDENDUM ACKNOWLEDGEMENT FORM
SOLICITATION NO.: CRFO DOT2100000098

Instructions: Please acknowledge receipt of all addenda issued with this solicitation by completing this addendum acknowledgment form. Check the box next to each addendum received and sign below. Failure to acknowledge addenda may result in bid disqualification.

Acknowledgment: I hereby acknowledge receipt of the following addenda and have made the necessary revisions to my proposal, plans and/or specification, etc.

Addendum Numbers Received:

(Check the box next to each addendum received)

- | | |
|--|--|
| <input checked="" type="checkbox"/> Addendum No. 1 | <input type="checkbox"/> Addendum No. 6 |
| <input type="checkbox"/> Addendum No. 2 | <input type="checkbox"/> Addendum No. 7 |
| <input type="checkbox"/> Addendum No. 3 | <input type="checkbox"/> Addendum No. 8 |
| <input type="checkbox"/> Addendum No. 4 | <input type="checkbox"/> Addendum No. 9 |
| <input type="checkbox"/> Addendum No. 5 | <input type="checkbox"/> Addendum No. 10 |

I understand that failure to confirm the receipt of addenda may be cause for rejection of this bid. I further understand that that any verbal representation made or assumed to be made during any oral discussion held between Vendor's representatives and any state personnel is not binding. Only the information issued in writing and added to the specifications by an official addendum is binding.

RAT Enterprises, Inc
Company
[Signature]
Authorized Signature
3-24-2021
Date

NOTE: This addendum acknowledgment should be submitted with the bid to expedite document processing.

GENERAL TERMS AND CONDITIONS:

1. CONTRACTUAL AGREEMENT: Issuance of a Award Document signed by the Purchasing Division Director, or his designee, and approved as to form by the Attorney General's office constitutes acceptance of this Contract made by and between the State of West Virginia and the Vendor. Vendor's signature on its bid signifies Vendor's agreement to be bound by and accept the terms and conditions contained in this Contract.

2. DEFINITIONS: As used in this Solicitation/Contract, the following terms shall have the meanings attributed to them below. Additional definitions may be found in the specifications included with this Solicitation/Contract.

2.1. "Agency" or "Agencies" means the agency, board, commission, or other entity of the State of West Virginia that is identified on the first page of the Solicitation or any other public entity seeking to procure goods or services under this Contract.

2.2. "Bid" or "Proposal" means the vendors submitted response to this solicitation.

2.3. "Contract" means the binding agreement that is entered into between the State and the Vendor to provide the goods or services requested in the Solicitation.

2.4. "Director" means the Director of the West Virginia Department of Administration, Purchasing Division.

2.5. "Purchasing Division" means the West Virginia Department of Administration, Purchasing Division.

2.6. "Award Document" means the document signed by the Agency and the Purchasing Division, and approved as to form by the Attorney General, that identifies the Vendor as the contract holder.

2.7. "Solicitation" means the official notice of an opportunity to supply the State with goods or services that is published by the Purchasing Division.

2.8. "State" means the State of West Virginia and/or any of its agencies, commissions, boards, etc. as context requires.

2.9. "Vendor" or "Vendors" means any entity submitting a bid in response to the Solicitation, the entity that has been selected as the lowest responsible bidder, or the entity that has been awarded the Contract as context requires.

3. CONTRACT TERM; RENEWAL; EXTENSION: The term of this Contract shall be determined in accordance with the category that has been identified as applicable to this Contract below:

Term Contract

Initial Contract Term: **Initial Contract Term:** This Contract becomes effective on _____ and extends for a period of _____ year(s).

Renewal Term: This Contract may be renewed upon the mutual written consent of the Agency, and the Vendor, with approval of the Purchasing Division and the Attorney General's office (Attorney General approval is as to form only). Any request for renewal should be delivered to the Agency and then submitted to the Purchasing Division thirty (30) days prior to the expiration date of the initial contract term or appropriate renewal term. A Contract renewal shall be in accordance with the terms and conditions of the original contract. Unless otherwise specified below, renewal of this Contract is limited to _____ successive one (1) year periods or multiple renewal periods of less than one year, provided that the multiple renewal periods do not exceed the total number of months available in all renewal years combined. Automatic renewal of this Contract is prohibited. Renewals must be approved by the Vendor, Agency, Purchasing Division and Attorney General's office (Attorney General approval is as to form only)

Alternate Renewal Term – This contract may be renewed for _____ successive _____ year periods or shorter periods provided that they do not exceed the total number of months contained in all available renewals. Automatic renewal of this Contract is prohibited. Renewals must be approved by the Vendor, Agency, Purchasing Division and Attorney General's office (Attorney General approval is as to form only)

Delivery Order Limitations: In the event that this contract permits delivery orders, a delivery order may only be issued during the time this Contract is in effect. Any delivery order issued within one year of the expiration of this Contract shall be effective for one year from the date the delivery order is issued. No delivery order may be extended beyond one year after this Contract has expired.

Fixed Period Contract: This Contract becomes effective upon Vendor's receipt of the notice to proceed and must be completed within ³⁰ _____ days.

Fixed Period Contract with Renewals: This Contract becomes effective upon Vendor's receipt of the notice to proceed and part of the Contract more fully described in the attached specifications must be completed within _____ days. Upon completion of the work covered by the preceding sentence, the vendor agrees that maintenance, monitoring, or warranty services will be provided for _____ year(s) thereafter.

One Time Purchase: The term of this Contract shall run from the issuance of the Award Document until all of the goods contracted for have been delivered, but in no event will this Contract extend for more than one fiscal year.

Other: See attached.

4. NOTICE TO PROCEED: Vendor shall begin performance of this Contract immediately upon receiving notice to proceed unless otherwise instructed by the Agency. Unless otherwise specified, the fully executed Award Document will be considered notice to proceed.

5. QUANTITIES: The quantities required under this Contract shall be determined in accordance with the category that has been identified as applicable to this Contract below.

Open End Contract: Quantities listed in this Solicitation are approximations only, based on estimates supplied by the Agency. It is understood and agreed that the Contract shall cover the quantities actually ordered for delivery during the term of the Contract, whether more or less than the quantities shown.

Service: The scope of the service to be provided will be more clearly defined in the specifications included herewith.

Combined Service and Goods: The scope of the service and deliverable goods to be provided will be more clearly defined in the specifications included herewith.

One Time Purchase: This Contract is for the purchase of a set quantity of goods that are identified in the specifications included herewith. Once those items have been delivered, no additional goods may be procured under this Contract without an appropriate change order approved by the Vendor, Agency, Purchasing Division, and Attorney General's office.

6. EMERGENCY PURCHASES: The Purchasing Division Director may authorize the Agency to purchase goods or services in the open market that Vendor would otherwise provide under this Contract if those goods or services are for immediate or expedited delivery in an emergency. Emergencies shall include, but are not limited to, delays in transportation or an unanticipated increase in the volume of work. An emergency purchase in the open market, approved by the Purchasing Division Director, shall not constitute a breach of this Contract and shall not entitle the Vendor to any form of compensation or damages. This provision does not excuse the State from fulfilling its obligations under a One Time Purchase contract.

7. REQUIRED DOCUMENTS: All of the items checked below must be provided to the Purchasing Division by the Vendor as specified below.

BID BOND (Construction Only): Pursuant to the requirements contained in W. Va. Code § 5-22-1(c), All Vendors submitting a bid on a construction project shall furnish a valid bid bond in the amount of five percent (5%) of the total amount of the bid protecting the State of West Virginia. The bid bond must be submitted with the bid.

PERFORMANCE BOND: The apparent successful Vendor shall provide a performance bond in the amount of 100% of the contract. The performance bond must be received by the Purchasing Division prior to Contract award.

LABOR/MATERIAL PAYMENT BOND: The apparent successful Vendor shall provide a labor/material payment bond in the amount of 100% of the Contract value. The labor/material payment bond must be delivered to the Purchasing Division prior to Contract award.

In lieu of the Bid Bond, Performance Bond, and Labor/Material Payment Bond, the Vendor may provide certified checks, cashier's checks, or irrevocable letters of credit. Any certified check, cashier's check, or irrevocable letter of credit provided in lieu of a bond must be of the same amount and delivered on the same schedule as the bond it replaces. A letter of credit submitted in lieu of a performance and labor/material payment bond will only be allowed for projects under \$100,000. Personal or business checks are not acceptable. Notwithstanding the foregoing, West Virginia Code § 5-22-1 (d) mandates that a vendor provide a performance and labor/material payment bond for construction projects. Accordingly, substitutions for the performance and labor/material payment bonds for construction projects is not permitted.

MAINTENANCE BOND: The apparent successful Vendor shall provide a two (2) year maintenance bond covering the roofing system. The maintenance bond must be issued and delivered to the Purchasing Division prior to Contract award.

LICENSE(S) / CERTIFICATIONS / PERMITS: In addition to anything required under the Section of the General Terms and Conditions entitled Licensing, the apparent successful Vendor shall furnish proof of the following licenses, certifications, and/or permits upon request and in a form acceptable to the State. The request may be prior to or after contract award at the State's sole discretion.

WV General Contractors License

The apparent successful Vendor shall also furnish proof of any additional licenses or certifications contained in the specifications regardless of whether or not that requirement is listed above.

8. INSURANCE: The apparent successful Vendor shall furnish proof of the insurance identified by a checkmark below and must include the State as an additional insured on each policy prior to Contract award. The insurance coverages identified below must be maintained throughout the life of this contract. Thirty (30) days prior to the expiration of the insurance policies, Vendor shall provide the Agency with proof that the insurance mandated herein has been continued. Vendor must also provide Agency with immediate notice of any changes in its insurance policies, including but not limited to, policy cancelation, policy reduction, or change in insurers. The apparent successful Vendor shall also furnish proof of any additional insurance requirements contained in the specifications prior to Contract award regardless of whether or not that insurance requirement is listed in this section.

Vendor must maintain:

Commercial General Liability Insurance in at least an amount of: \$100,000 per occurrence.

Automobile Liability Insurance in at least an amount of: _____ per occurrence.

Professional/Malpractice/Errors and Omission Insurance in at least an amount of: _____ per occurrence. Notwithstanding the forgoing, Vendor's are not required to list the State as an additional insured for this type of policy.

Commercial Crime and Third Party Fidelity Insurance in an amount of: _____ per occurrence.

Cyber Liability Insurance in an amount of: _____ per occurrence.

Builders Risk Insurance in an amount equal to 100% of the amount of the Contract.

Pollution Insurance in an amount of: _____ per occurrence.

Aircraft Liability in an amount of: _____ per occurrence.

*** State of West Virginia must be listed as additional insured on insurance certificate ***

*** Certificate holder should read as follows: ***
State of WV
1900 Kanawha Blvd., E., Bldg. 5
Charleston, WV 25305

Notwithstanding anything contained in this section to the contrary, the Director of the Purchasing Division reserves the right to waive the requirement that the State be named as an additional insured on one or more of the Vendor's insurance policies if the Director finds that doing so is in the State's best interest.

9. WORKERS' COMPENSATION INSURANCE: The apparent successful Vendor shall comply with laws relating to workers compensation, shall maintain workers' compensation insurance when required, and shall furnish proof of workers' compensation insurance upon request.

10. [Reserved]

11. LIQUIDATED DAMAGES: This clause shall in no way be considered exclusive and shall not limit the State or Agency's right to pursue any other available remedy. Vendor shall pay liquidated damages in the amount specified below or as described in the specifications:

\$40 per day _____ for period of contract _____

Liquidated Damages Contained in the Specifications

12. ACCEPTANCE: Vendor's signature on its bid, or on the certification and signature page, constitutes an offer to the State that cannot be unilaterally withdrawn, signifies that the product or service proposed by vendor meets the mandatory requirements contained in the Solicitation for that product or service, unless otherwise indicated, and signifies acceptance of the terms and conditions contained in the Solicitation unless otherwise indicated.

13. PRICING: The pricing set forth herein is firm for the life of the Contract, unless specified elsewhere within this Solicitation/Contract by the State. A Vendor's inclusion of price adjustment provisions in its bid, without an express authorization from the State in the Solicitation to do so, may result in bid disqualification. Notwithstanding the foregoing, Vendor must extend any publicly advertised sale price to the State and invoice at the lower of the contract price or the publicly advertised sale price.

14. PAYMENT IN ARREARS: Payment in advance is prohibited under this Contract. Payment may only be made after the delivery and acceptance of goods or services. The Vendor shall submit invoices, in arrears.

15. PAYMENT METHODS: Vendor must accept payment by electronic funds transfer and P-Card. (The State of West Virginia's Purchasing Card program, administered under contract by a banking institution, processes payment for goods and services through state designated credit cards.)

16. TAXES: The Vendor shall pay any applicable sales, use, personal property or any other taxes arising out of this Contract and the transactions contemplated thereby. The State of West Virginia is exempt from federal and state taxes and will not pay or reimburse such taxes.

17. ADDITIONAL FEES: Vendor is not permitted to charge additional fees or assess additional charges that were not either expressly provided for in the solicitation published by the State of West Virginia or included in the unit price or lump sum bid amount that Vendor is required by the solicitation to provide. Including such fees or charges as notes to the solicitation may result in rejection of vendor's bid. Requesting such fees or charges be paid after the contract has been awarded may result in cancellation of the contract.

18. FUNDING: This Contract shall continue for the term stated herein, contingent upon funds being appropriated by the Legislature or otherwise being made available. In the event funds are not appropriated or otherwise made available, this Contract becomes void and of no effect beginning on July 1 of the fiscal year for which funding has not been appropriated or otherwise made available.

19. CANCELLATION: The Purchasing Division Director reserves the right to cancel this Contract immediately upon written notice to the vendor if the materials or workmanship supplied do not conform to the specifications contained in the Contract. The Purchasing Division Director may also cancel any purchase or Contract upon 30 days written notice to the Vendor in accordance with West Virginia Code of State Rules § 148-1-5.2.b.

20. TIME: Time is of the essence with regard to all matters of time and performance in this Contract.

21. APPLICABLE LAW: This Contract is governed by and interpreted under West Virginia law without giving effect to its choice of law principles. Any information provided in specification manuals, or any other source, verbal or written, which contradicts or violates the West Virginia Constitution, West Virginia Code or West Virginia Code of State Rules is void and of no effect.

22. COMPLIANCE WITH LAWS: Vendor shall comply with all applicable federal, state, and local laws, regulations and ordinances. By submitting a bid, Vendor acknowledges that it has reviewed, understands, and will comply with all applicable laws, regulations, and ordinances.

SUBCONTRACTOR COMPLIANCE: Vendor shall notify all subcontractors providing commodities or services related to this Contract that as subcontractors, they too are required to comply with all applicable laws, regulations, and ordinances. Notification under this provision must occur prior to the performance of any work under the contract by the subcontractor.

23. ARBITRATION: Any references made to arbitration contained in this Contract, Vendor's bid, or in any American Institute of Architects documents pertaining to this Contract are hereby deleted, void, and of no effect.

24. MODIFICATIONS: This writing is the parties' final expression of intent. Notwithstanding anything contained in this Contract to the contrary no modification of this Contract shall be binding without mutual written consent of the Agency, and the Vendor, with approval of the Purchasing Division and the Attorney General's office (Attorney General approval is as to form only). Any change to existing contracts that adds work or changes contract cost, and were not included in the original contract, must be approved by the Purchasing Division and the Attorney General's Office (as to form) prior to the implementation of the change or commencement of work affected by the change.

25. WAIVER: The failure of either party to insist upon a strict performance of any of the terms or provision of this Contract, or to exercise any option, right, or remedy herein contained, shall not be construed as a waiver or a relinquishment for the future of such term, provision, option, right, or remedy, but the same shall continue in full force and effect. Any waiver must be expressly stated in writing and signed by the waiving party.

26. SUBSEQUENT FORMS: The terms and conditions contained in this Contract shall supersede any and all subsequent terms and conditions which may appear on any form documents submitted by Vendor to the Agency or Purchasing Division such as price lists, order forms, invoices, sales agreements, or maintenance agreements, and includes internet websites or other electronic documents. Acceptance or use of Vendor's forms does not constitute acceptance of the terms and conditions contained thereon.

27. ASSIGNMENT: Neither this Contract nor any monies due, or to become due hereunder, may be assigned by the Vendor without the express written consent of the Agency, the Purchasing Division, the Attorney General's office (as to form only), and any other government agency or office that may be required to approve such assignments.

28. WARRANTY: The Vendor expressly warrants that the goods and/or services covered by this Contract will: (a) conform to the specifications, drawings, samples, or other description furnished or specified by the Agency; (b) be merchantable and fit for the purpose intended; and (c) be free from defect in material and workmanship.

29. STATE EMPLOYEES: State employees are not permitted to utilize this Contract for personal use and the Vendor is prohibited from permitting or facilitating the same.

30. PRIVACY, SECURITY, AND CONFIDENTIALITY: The Vendor agrees that it will not disclose to anyone, directly or indirectly, any such personally identifiable information or other confidential information gained from the Agency, unless the individual who is the subject of the information consents to the disclosure in writing or the disclosure is made pursuant to the Agency's policies, procedures, and rules. Vendor further agrees to comply with the Confidentiality Policies and Information Security Accountability Requirements, set forth in <http://www.state.wv.us/admin/purchase/privacy/default.html>.

31. YOUR SUBMISSION IS A PUBLIC DOCUMENT: Vendor's entire response to the Solicitation and the resulting Contract are public documents. As public documents, they will be disclosed to the public following the bid/proposal opening or award of the contract, as required by the competitive bidding laws of West Virginia Code §§ 5A-3-1 et seq., 5-22-1 et seq., and 5G-1-1 et seq. and the Freedom of Information Act West Virginia Code §§ 29B-1-1 et seq.

DO NOT SUBMIT MATERIAL YOU CONSIDER TO BE CONFIDENTIAL, A TRADE SECRET, OR OTHERWISE NOT SUBJECT TO PUBLIC DISCLOSURE.

Submission of any bid, proposal, or other document to the Purchasing Division constitutes your explicit consent to the subsequent public disclosure of the bid, proposal, or document. The Purchasing Division will disclose any document labeled "confidential," "proprietary," "trade secret," "private," or labeled with any other claim against public disclosure of the documents, to include any "trade secrets" as defined by West Virginia Code § 47-22-1 et seq. All submissions are subject to public disclosure without notice.

32. LICENSING: In accordance with West Virginia Code of State Rules § 148-1-6.1.e, Vendor must be licensed and in good standing in accordance with any and all state and local laws and requirements by any state or local agency of West Virginia, including, but not limited to, the West Virginia Secretary of State's Office, the West Virginia Tax Department, West Virginia Insurance Commission, or any other state agency or political subdivision. Obligations related to political subdivisions may include, but are not limited to, business licensing, business and occupation taxes, inspection compliance, permitting, etc. Upon request, the Vendor must provide all necessary releases to obtain information to enable the Purchasing Division Director or the Agency to verify that the Vendor is licensed and in good standing with the above entities.

SUBCONTRACTOR COMPLIANCE: Vendor shall notify all subcontractors providing commodities or services related to this Contract that as subcontractors, they too are required to be licensed, in good standing, and up-to-date on all state and local obligations as described in this section. Obligations related to political subdivisions may include, but are not limited to, business licensing, business and occupation taxes, inspection compliance, permitting, etc. Notification under this provision must occur prior to the performance of any work under the contract by the subcontractor.

33. ANTITRUST: In submitting a bid to, signing a contract with, or accepting a Award Document from any agency of the State of West Virginia, the Vendor agrees to convey, sell, assign, or transfer to the State of West Virginia all rights, title, and interest in and to all causes of action it may now or hereafter acquire under the antitrust laws of the United States and the State of West Virginia for price fixing and/or unreasonable restraints of trade relating to the particular commodities or services purchased or acquired by the State of West Virginia. Such assignment shall be made and become effective at the time the purchasing agency tenders the initial payment to Vendor.

34. VENDOR CERTIFICATIONS: By signing its bid or entering into this Contract, Vendor certifies (1) that its bid or offer was made without prior understanding, agreement, or connection with any corporation, firm, limited liability company, partnership, person or entity submitting a bid or offer for the same material, supplies, equipment or services; (2) that its bid or offer is in all respects fair and without collusion or fraud; (3) that this Contract is accepted or entered into without any prior understanding, agreement, or connection to any other entity that could be considered a violation of law; and (4) that it has reviewed this Solicitation in its entirety; understands the requirements, terms and conditions, and other information contained herein.

Vendor's signature on its bid or offer also affirms that neither it nor its representatives have any interest, nor shall acquire any interest, direct or indirect, which would compromise the performance of its services hereunder. Any such interests shall be promptly presented in detail to the Agency. The individual signing this bid or offer on behalf of Vendor certifies that he or she is authorized by the Vendor to execute this bid or offer or any documents related thereto on Vendor's behalf; that he or she is authorized to bind the Vendor in a contractual relationship; and that, to the best of his or her knowledge, the Vendor has properly registered with any State agency that may require registration.

35. VENDOR RELATIONSHIP: The relationship of the Vendor to the State shall be that of an independent contractor and no principal-agent relationship or employer-employee relationship is contemplated or created by this Contract. The Vendor as an independent contractor is solely liable for the acts and omissions of its employees and agents. Vendor shall be responsible for selecting, supervising, and compensating any and all individuals employed pursuant to the terms of this Solicitation and resulting contract. Neither the Vendor, nor any employees or subcontractors of the Vendor, shall be deemed to be employees of the State for any purpose whatsoever. Vendor shall be exclusively responsible for payment of employees and contractors for all wages and salaries, taxes, withholding payments, penalties, fees, fringe benefits, professional liability insurance premiums, contributions to insurance and pension, or other deferred compensation plans, including but not limited to, Workers' Compensation and Social Security obligations, licensing fees, etc. and the filing of all necessary documents, forms, and returns pertinent to all of the foregoing.

Vendor shall hold harmless the State, and shall provide the State and Agency with a defense against any and all claims including, but not limited to, the foregoing payments, withholdings, contributions, taxes, Social Security taxes, and employer income tax returns.

36. INDEMNIFICATION: The Vendor agrees to indemnify, defend, and hold harmless the State and the Agency, their officers, and employees from and against: (1) Any claims or losses for services rendered by any subcontractor, person, or firm performing or supplying services, materials, or supplies in connection with the performance of the Contract; (2) Any claims or losses resulting to any person or entity injured or damaged by the Vendor, its officers, employees, or subcontractors by the publication, translation, reproduction, delivery, performance, use, or disposition of any data used under the Contract in a manner not authorized by the Contract, or by Federal or State statutes or regulations; and (3) Any failure of the Vendor, its officers, employees, or subcontractors to observe State and Federal laws including, but not limited to, labor and wage and hour laws.

37. PURCHASING AFFIDAVIT: In accordance with West Virginia Code §§ 5A-3-10a and 5-22-1(i), the State is prohibited from awarding a contract to any bidder that owes a debt to the State or a political subdivision of the State, Vendors are required to sign, notarize, and submit the Purchasing Affidavit to the Purchasing Division affirming under oath that it is not in default on any monetary obligation owed to the state or a political subdivision of the state.

38. ADDITIONAL AGENCY AND LOCAL GOVERNMENT USE: This Contract may be utilized by other agencies, spending units, and political subdivisions of the State of West Virginia; county, municipal, and other local government bodies; and school districts (“Other Government Entities”), provided that both the Other Government Entity and the Vendor agree. Any extension of this Contract to the aforementioned Other Government Entities must be on the same prices, terms, and conditions as those offered and agreed to in this Contract, provided that such extension is in compliance with the applicable laws, rules, and ordinances of the Other Government Entity. A refusal to extend this Contract to the Other Government Entities shall not impact or influence the award of this Contract in any manner.

39. CONFLICT OF INTEREST: Vendor, its officers or members or employees, shall not presently have or acquire an interest, direct or indirect, which would conflict with or compromise the performance of its obligations hereunder. Vendor shall periodically inquire of its officers, members and employees to ensure that a conflict of interest does not arise. Any conflict of interest discovered shall be promptly presented in detail to the Agency.

40. REPORTS: Vendor shall provide the Agency and/or the Purchasing Division with the following reports identified by a checked box below:

Such reports as the Agency and/or the Purchasing Division may request. Requested reports may include, but are not limited to, quantities purchased, agencies utilizing the contract, total contract expenditures by agency, etc.

Quarterly reports detailing the total quantity of purchases in units and dollars, along with a listing of purchases by agency. Quarterly reports should be delivered to the Purchasing Division via email at purchasing.requisitions@wv.gov.

41. BACKGROUND CHECK: In accordance with W. Va. Code § 15-2D-3, the Director of the Division of Protective Services shall require any service provider whose employees are regularly employed on the grounds or in the buildings of the Capitol complex or who have access to sensitive or critical information to submit to a fingerprint-based state and federal background inquiry through the state repository. The service provider is responsible for any costs associated with the fingerprint-based state and federal background inquiry.

After the contract for such services has been approved, but before any such employees are permitted to be on the grounds or in the buildings of the Capitol complex or have access to sensitive or critical information, the service provider shall submit a list of all persons who will be physically present and working at the Capitol complex to the Director of the Division of Protective Services for purposes of verifying compliance with this provision. The State reserves the right to prohibit a service provider’s employees from accessing sensitive or critical information or to be present at the Capitol complex based upon results addressed from a criminal background check.

Revised 01/09/2020

Service providers should contact the West Virginia Division of Protective Services by phone at (304) 558-9911 for more information.

42. PREFERENCE FOR USE OF DOMESTIC STEEL PRODUCTS: Except when authorized by the Director of the Purchasing Division pursuant to W. Va. Code § 5A-3-56, no contractor may use or supply steel products for a State Contract Project other than those steel products made in the United States. A contractor who uses steel products in violation of this section may be subject to civil penalties pursuant to W. Va. Code § 5A-3-56. As used in this section:

- a. "State Contract Project" means any erection or construction of, or any addition to, alteration of or other improvement to any building or structure, including, but not limited to, roads or highways, or the installation of any heating or cooling or ventilating plants or other equipment, or the supply of and materials for such projects, pursuant to a contract with the State of West Virginia for which bids were solicited on or after June 6, 2001.
- b. "Steel Products" means products rolled, formed, shaped, drawn, extruded, forged, cast, fabricated or otherwise similarly processed, or processed by a combination of two or more or such operations, from steel made by the open heath, basic oxygen, electric furnace, Bessemer or other steel making process. The Purchasing Division Director may, in writing, authorize the use of foreign steel products if:
- c. The cost for each contract item used does not exceed one tenth of one percent (.1%) of the total contract cost or two thousand five hundred dollars (\$2,500.00), whichever is greater. For the purposes of this section, the cost is the value of the steel product as delivered to the project; or
- d. The Director of the Purchasing Division determines that specified steel materials are not produced in the United States in sufficient quantity or otherwise are not reasonably available to meet contract requirements.

43. PREFERENCE FOR USE OF DOMESTIC ALUMINUM, GLASS, AND STEEL: In Accordance with W. Va. Code § 5-19-1 et seq., and W. Va. CSR § 148-10-1 et seq., for every contract or subcontract, subject to the limitations contained herein, for the construction, reconstruction, alteration, repair, improvement or maintenance of public works or for the purchase of any item of machinery or equipment to be used at sites of public works, only domestic aluminum, glass or steel products shall be supplied unless the spending officer determines, in writing, after the receipt of offers or bids, (1) that the cost of domestic aluminum, glass or steel products is unreasonable or inconsistent with the public interest of the State of West Virginia, (2) that domestic aluminum, glass or steel products are not produced in sufficient quantities to meet the contract requirements, or (3) the available domestic aluminum, glass, or steel do not meet the contract specifications. This provision only applies to public works contracts awarded in an amount more than fifty thousand dollars (\$50,000) or public works contracts that require more than ten thousand pounds of steel products.

The cost of domestic aluminum, glass, or steel products may be unreasonable if the cost is more than twenty percent (20%) of the bid or offered price for foreign made aluminum, glass, or steel products. If the domestic aluminum, glass or steel products to be supplied or produced in a

“substantial labor surplus area”, as defined by the United States Department of Labor, the cost of domestic aluminum, glass, or steel products may be unreasonable if the cost is more than thirty percent (30%) of the bid or offered price for foreign made aluminum, glass, or steel products. This preference shall be applied to an item of machinery or equipment, as indicated above, when the item is a single unit of equipment or machinery manufactured primarily of aluminum, glass or steel, is part of a public works contract and has the sole purpose or of being a permanent part of a single public works project. This provision does not apply to equipment or machinery purchased by a spending unit for use by that spending unit and not as part of a single public works project.

All bids and offers including domestic aluminum, glass or steel products that exceed bid or offer prices including foreign aluminum, glass or steel products after application of the preferences provided in this provision may be reduced to a price equal to or lower than the lowest bid or offer price for foreign aluminum, glass or steel products plus the applicable preference. If the reduced bid or offer prices are made in writing and supersede the prior bid or offer prices, all bids or offers, including the reduced bid or offer prices, will be reevaluated in accordance with this rule.

44. INTERESTED PARTY SUPPLEMENTAL DISCLOSURE: W. Va. Code § 6D-1-2 requires that for contracts with an actual or estimated value of at least \$1 million, the vendor must submit to the Agency a supplemental disclosure of interested parties reflecting any new or differing interested parties to the contract, which were not included in the original pre-award interested party disclosure, within 30 days following the completion or termination of the contract. A copy of that form is included with this solicitation or can be obtained from the WV Ethics Commission. This requirement does not apply to publicly traded companies listed on a national or international stock exchange. A more detailed definition of interested parties can be obtained from the form referenced above.

45. PROHIBITION AGAINST USED OR REFURBISHED: Unless expressly permitted in the solicitation published by the State, Vendor must provide new, unused commodities, and is prohibited from supplying used or refurbished commodities, in fulfilling its responsibilities under this Contract.

ADDITIONAL TERMS AND CONDITIONS (Construction Contracts Only)

1. CONTRACTOR'S LICENSE: West Virginia Code § 21-11-2 requires that all persons desiring to perform contracting work in this state be licensed. The West Virginia Contractors Licensing Board is empowered to issue the contractor's license. Applications for a contractor's license may be made by contacting the West Virginia Division of Labor. West Virginia Code § 21-11-11 requires any prospective Vendor to include the contractor's license number on its bid. If an apparent low bidder fails to submit a license number in accordance with this section, the Purchasing Division will promptly request by telephone and electronic mail that the low bidder and the second low bidder provide the license number within one business day of the request. Failure of the bidder to provide the license number within one business day of receiving the request shall result in disqualification of the bid. Vendors should include a contractor's license number in the space provided below.

Contractor's Name: Reft Enterprises, Inc.
Contractor's License No.: WV- 033149

The apparent successful Vendor must furnish a copy of its contractor's license prior to the issuance of a contract award document.

2. DRUG-FREE WORKPLACE AFFIDAVIT: W. Va. Code § 21-1D-5 provides that any solicitation for a public improvement contract requires each Vendor that submits a bid for the work to submit an affidavit that the Vendor has a written plan for a drug-free workplace policy. If the affidavit is not submitted with the bid submission, the Purchasing Division shall promptly request by telephone and electronic mail that the low bidder and second low bidder provide the affidavit within one business day of the request. Failure to submit the affidavit within one business day of receiving the request shall result in disqualification of the bid. To comply with this law, Vendor should complete the enclosed drug-free workplace affidavit and submit the same with its bid. Failure to submit the signed and notarized drugfree workplace affidavit or a similar affidavit that fully complies with the requirements of the applicable code, within one business day of being requested to do so shall result in disqualification of Vendor's bid. Pursuant to W. Va. Code 21-1D-2(b) and (k), this provision does not apply to public improvement contracts the value of which is \$100,000 or less or temporary or emergency repairs.

2.1. DRUG-FREE WORKPLACE POLICY: Pursuant to W. Va. Code § 21-1D-4, Vendor and its subcontractors must implement and maintain a written drug-free workplace policy that complies with said article. The awarding public authority shall cancel this contract if: (1) Vendor fails to implement and maintain a written drug-free workplace policy described in the preceding paragraph, (2) Vendor fails to provide information regarding implementation of its drug-free workplace policy at the request of the public authority; or (3) Vendor provides to the public authority false information regarding the contractor's drug-free workplace policy.

Pursuant to W. Va. Code 21-1D-2(b) and (k), this provision does not apply to public improvement contracts the value of which is \$100,000 or less or temporary or emergency repairs.

3. DRUG FREE WORKPLACE REPORT: Pursuant to W. Va. Code § 21-1D-7b, no less than once per year, or upon completion of the project, every contractor shall provide a certified report to the public authority which let the contract. For contracts over \$25,000, the public authority shall be the West Virginia Purchasing Division. For contracts of \$25,000 or less, the public authority shall be the agency issuing the contract. The report shall include:

- (1) Information to show that the education and training service to the requirements of West Virginia Code § 21-1D-5 was provided;
- (2) The name of the laboratory certified by the United States Department of Health and Human Services or its successor that performs the drug tests;
- (3) The average number of employees in connection with the construction on the public improvement;
- (4) Drug test results for the following categories including the number of positive tests and the number of negative tests: (A) Pre-employment and new hires; (B) Reasonable suspicion; (C) Post-accident; and (D) Random.

Vendor should utilize the attached Certified Drug Free Workplace Report Coversheet when submitting the report required hereunder. Pursuant to W. Va. Code 21-1D-2(b) and (k), this provision does not apply to public improvement contracts the value of which is \$100,000 or less or temporary or emergency repairs.

4. AIA DOCUMENTS: All construction contracts that will be completed in conjunction with architectural services procured under Chapter 5G of the West Virginia Code will be governed by the attached AIA documents, as amended by the Supplementary Conditions for the State of West Virginia, in addition to the terms and conditions contained herein.

4A. PROHIBITION AGAINST GENERAL CONDITIONS: Notwithstanding anything contained in the AIA Documents or the Supplementary Conditions, the State of West Virginia will not pay for general conditions, or winter conditions, or any other condition representing a delay in the contracts. The Vendor is expected to mitigate delay costs to the greatest extent possible and any costs associated with Delays must be specifically and concretely identified. The state will not consider an average daily rate multiplied by the number of days extended to be an acceptable charge.

5. GREEN BUILDINGS MINIMUM ENERGY STANDARDS: In accordance with § 22-29-4, all new building construction projects of public agencies that have not entered the schematic design phase prior to July 1, 2012, or any building construction project receiving state grant funds and appropriations, including public schools, that have not entered the schematic design phase prior to July 1, 2012, shall be designed and constructed complying with the ICC International Energy Conservation Code, adopted by the State Fire Commission, and the ANSI/ASHRAE/IESNA Standard 90.1-2007: Provided, That if any construction project has a commitment of federal funds to pay for a portion of such project, this provision shall only apply to the extent such standards are consistent with the federal standards.

6. LOCAL LABOR MARKET HIRING REQUIREMENT: Pursuant to West Virginia Code §21-1C-1 et seq., Employers shall hire at least seventy-five percent of employees for public improvement construction projects from the local labor market, to be rounded off, with at least two employees from outside the local labor market permissible for each employer per project.

Any employer unable to employ the minimum number of employees from the local labor market shall inform the nearest office of Workforce West Virginia of the number of qualified employees needed and provide a job description of the positions to be filled.

If, within three business days following the placing of a job order, Workforce West Virginia is unable to refer any qualified job applicants to the employer or refers less qualified job applicants than the number requested, then Workforce West Virginia shall issue a waiver to the employer stating the unavailability of applicant and shall permit the employer to fill any positions covered by the waiver from outside the local labor market. The waiver shall be in writing and shall be issued within the prescribed three days. A waiver certificate shall be sent to both the employer for its permanent project records and to the public authority.

Any employer who violates this requirement is subject to a civil penalty of \$250 per each employee less than the required threshold of seventy-five percent per day of violation after receipt of a notice of violation.

Any employer that continues to violate any provision of this article more than fourteen calendar days after receipt of a notice of violation is subject to a civil penalty of \$500 per each employee less than the required threshold of seventy-five percent per day of violation.

The following terms used in this section have the meaning shown below.

(1) The term “construction project” means any construction, reconstruction, improvement, enlargement, painting, decorating or repair of any public improvement let to contract in an amount equal to or greater than \$500,000. The term “construction project” does not include temporary or emergency repairs;

(2) The term “employee” means any person hired or permitted to perform hourly work for wages by a person, firm or corporation in the construction industry; The term “employee” does not include:(i) Bona fide employees of a public authority or individuals engaged in making temporary or emergency repairs;(ii) Bona fide independent contractors; or(iii) Salaried supervisory personnel necessary to assure efficient execution of the employee's work;

(3) The term “employer” means any person, firm or corporation employing one or more employees on any public improvement and includes all contractors and subcontractors;

(4) The term “local labor market” means every county in West Virginia and any county outside of West Virginia if any portion of that county is within fifty miles of the border of West Virginia;

(5) The term “public improvement” includes the construction of all buildings, roads, highways, bridges, streets, alleys, sewers, ditches, sewage disposal plants, waterworks, airports and all other structures that may be let to contract by a public authority, excluding improvements funded, in whole or in part, by federal funds.

7. DAVIS-BACON AND RELATED ACT WAGE RATES:

- The work performed under this contract is federally funded in whole, or in part. Pursuant to _____, Vendors are required to pay applicable Davis-Bacon wage rates.
- The work performed under this contract is not subject to Davis-Bacon wage rates.

8. SUBCONTRACTOR LIST SUBMISSION: In accordance with W. Va. Code § 5-22-1, the apparent low bidder on a contract valued at more than \$250,000.00 for the construction, alteration, decoration, painting or improvement of a new or existing building or structure shall submit a list of all subcontractors who will perform more than \$25,000.00 of work on the project including labor and materials. (This section does not apply to any other construction projects, such as highway, mine reclamation, water or sewer projects.) The subcontractor list shall be provided to the Purchasing Division within one business day of the opening of bids for review. If the apparent low bidder fails to submit the subcontractor list, the Purchasing Division shall promptly request by telephone and electronic mail that the low bidder and second low bidder provide the subcontractor list within one business day of the request. Failure to submit the subcontractor list within one business day of receiving the request shall result in disqualification of the bid.

If no subcontractors who will perform more than \$25,000.00 of work are to be used to complete the project, the apparent low bidder must make this clear on the subcontractor list, in the bid itself, or in response to the Purchasing Division's request for the subcontractor list.

a. Required Information. The subcontractor list must contain the following information:

- i. Bidder's name
- ii. Name of each subcontractor performing more than \$25,000 of work on the project.
- iii. The license number of each subcontractor, as required by W. Va. Code § 21-11-1 et. seq.
- iv. If applicable, a notation that no subcontractor will be used to perform more than \$25,000.00 of work. (This item iv. is not required if the vendor makes this clear in the bid itself or in documentation following the request for the subcontractor list.)

b. Subcontractor List Submission Form: The subcontractor list may be submitted in any form, including the attached form, as long as the required information noted above is included. If any information is missing from the bidder's subcontractor list submission, it may be obtained from other documents such as bids, emails, letters, etc. that accompany the subcontractor list submission.

c. Substitution of Subcontractor. Written approval must be obtained from the State Spending Unit before any subcontractor substitution is permitted. Substitutions are not permitted unless:

- i. The subcontractor listed in the original bid has filed for bankruptcy;**
- ii. The subcontractor in the original bid has been debarred or suspended; or**
- iii. The contractor certifies in writing that the subcontractor listed in the original bid fails, is unable, or refuses to perform his subcontract.**

**ADDITIONAL TERMS AND CONDITIONS
(Architectural and Engineering Contracts Only)**

1. PLAN AND DRAWING DISTRIBUTION: All plans and drawings must be completed and available for distribution at least five business days prior to a scheduled pre-bid meeting for the construction or other work related to the plans and drawings.

2. PROJECT ADDENDA REQUIREMENTS: The Architect/Engineer and/or Agency shall be required to abide by the following schedule in issuing construction project addenda. The Architect/Engineer shall prepare any addendum materials for which it is responsible, and a list of all vendors that have obtained drawings and specifications for the project. The Architect/Engineer shall then send a copy of the addendum materials and the list of vendors to the State Agency for which the contract is issued to allow the Agency to make any necessary modifications. The addendum and list shall then be forwarded to the Purchasing Division buyer by the Agency. The Purchasing Division buyer shall send the addendum to all interested vendors and, if necessary, extend the bid opening date. Any addendum should be received by the Purchasing Division at least fourteen (14) days prior to the bid opening date.

3. PRE-BID MEETING RESPONSIBILITIES: The Architect/Engineer shall be available to attend any pre-bid meeting for the construction or other work resulting from the plans, drawings, or specifications prepared by the Architect/Engineer.

4. AIA DOCUMENTS: All construction contracts that will be completed in conjunction with architectural services procured under Chapter 5G of the West Virginia Code will be governed by the attached AIA documents, as amended by the Supplementary Conditions for the State of West Virginia, in addition to the terms and conditions contained herein. The terms and conditions of this document shall prevail over anything contained in the AIA Documents or the Supplementary Conditions.

5. GREEN BUILDINGS MINIMUM ENERGY STANDARDS: In accordance with West Virginia Code § 22-29-4, all new building construction projects of public agencies that have not entered the schematic design phase prior to July 1, 2012, or any building construction project receiving state grant funds and appropriations, including public schools, that have not entered the schematic design phase prior to July 1, 2012, shall be designed and constructed complying with the ICC International Energy Conservation Code, adopted by the State Fire Commission, and the ANSI/ASHRAE/IESNA Standard 90.1-2007: Provided, That if any construction project has a commitment of federal funds to pay for a portion of such project, this provision shall only apply to the extent such standards are consistent with the federal standards.

DESIGNATED CONTACT: Vendor appoints the individual identified in this Section as the Contract Administrator and the initial point of contact for matters relating to this Contract.

 President
(Name, Title)
Nathaniel G. Rohrig President
(Printed Name and Title)
P.O. Box 727, Bridgeport, WV 26330
(Address)
304-623-4827 304-622-5546
(Phone Number) / (Fax Number)
Nrohrig@901.com
(email address)

CERTIFICATION AND SIGNATURE: By signing below, or submitting documentation through wvOASIS, I certify that I have reviewed this Solicitation in its entirety; that I understand the requirements, terms and conditions, and other information contained herein; that this bid, offer or proposal constitutes an offer to the State that cannot be unilaterally withdrawn; that the product or service proposed meets the mandatory requirements contained in the Solicitation for that product or service, unless otherwise stated herein; that the Vendor accepts the terms and conditions contained in the Solicitation, unless otherwise stated herein; that I am submitting this bid, offer or proposal for review and consideration; that I am authorized by the vendor to execute and submit this bid, offer, or proposal, or any documents related thereto on vendor's behalf; that I am authorized to bind the vendor in a contractual relationship; and that to the best of my knowledge, the vendor has properly registered with any State agency that may require registration.

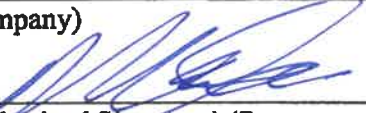
R&T Enterprises, Inc.
(Company)
 Nathaniel G. Rohrig, President
(Authorized Signature) (Representative Name, Title)
Nathaniel G. Rohrig, President
(Printed Name and Title of Authorized Representative)
3-24-2021
(Date)
304-623-4827 304-622-5546
(Phone Number) (Fax Number)



**State of West Virginia
DRUG FREE WORKPLACE CONFORMANCE AFFIDAVIT
West Virginia Code §21-1D-5**

I, Nathaniel G. Rohrig, after being first duly sworn, depose and state as follows:

1. I am an employee of R+T Enterprises, Inc; and,
(Company Name)
2. I do hereby attest that R+T Enterprises, Inc
(Company Name)

maintains a written plan for a drug-free workplace policy and that such plan and policy are in compliance with **West Virginia Code §21-1D**.

The above statements are sworn to under the penalty of perjury.

Printed Name: Nathaniel G. Rohrig
 Signature: [Signature]
 Title: President
 Company Name: R+T Enterprises, Inc
 Date: 3-23-2021

STATE OF WEST VIRGINIA,

COUNTY OF Harrison, TO-WIT:

Taken, subscribed and sworn to before me this 23 day of March, 2021.

By Commission expires November 17, 2025

(Seal)

[Signature]
(Notary Public)

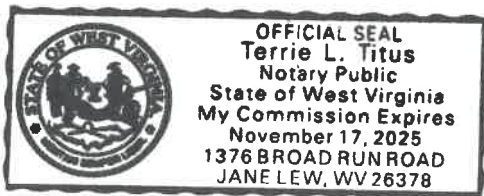

CONTRACTOR LICENSE

Authorized by the

West Virginia Contractor Licensing Board

Number: WV033149

Classification:

SPECIALTY

R & T ENTERPRISES INC
DBA R & T ENTERPRISES INC
PO BOX 727
BRIDGEPORT, WV 26330

Date Issued

Expiration Date

DECEMBER 07, 2020

DECEMBER 07, 2021

Authorized Company Signature

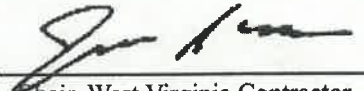

Chair, West Virginia Contractor
Licensing Board



**WEST VIRGINIA
CONTRACTOR
LICENSING
BOARD**

This license, or a copy thereof, must be posted in a conspicuous place at every construction site where work is being performed. This license number must appear in all advertisements, on all bid submissions and on all fully executed and binding contracts. This license cannot be assigned or transferred by licensee. Issued under provisions of West Virginia Code, Chapter 21, Article 11.

SYNERGY NON-FR FABRIC

RU88X-6 400 (IPG)



Strength & Durability

Synergy Non-FR Fabric is a heavy weight fabric with 4 mil coatings used for applications requiring minimally flame retardant material with ultraviolet stability. The scrim, which is the woven part of the material, is constructed of individual tapes. The unique composition of the tapes and how they are woven together gives Synergy Non-FR Fabric its tremendous rip, tear and puncture strength. The specialized 4 mil coatings are more resistant to abrasion damage during fabrication and installation of the fabric cover. Synergy Non-FR Fabric comes with a 20 year pro-rata warranty.

Safe & Environmentally Friendly

No toxic chemicals are used in the production of Synergy Non-FR Fabric. All scraps and used covers are 100% recyclable.

Bright Atmosphere

Synergy Non-FR Fabric covers provides an exceptionally bright and pleasant interior atmosphere. Natural light penetrates the fabric while the unique composition of the tapes ensures the cover remains pliable and resistant to ultraviolet damage. The Synergy Non-FR Fabric reduces the conduction of heat and cold, ensuring a building is warmer in the winter and cooler in the summer. The fabric is available in a variety of attractive colours all featuring a bright white underside that further enhances the interior brightness.

Patented double stack weave provides unmatched strength to weight ratios.



All covers feature a bright white underside that allows for maximum interior light.

Non-FR Fabric Specifications

Weave:	16 x 16 tapes/in (63 tapes/10 cm)	
Coating	4.0 mils average each side (95g/m ²)	
Thickness:		
Coating	Modified LDPE coating with UV protection	
Composition:		
Weight:	12 oz/yd ² (407 g/m ²) +/- 5%	
Thickness:	23 mils (0.59mm)	ASTM D1777
Grab Tensile:	Warp: 370lbs. (1664 N)	ASTM D5034
	Weft: 345 lbs. (1532 N)	ASTM D5034
Strip Tensile: (N/5cm)	Warp: 245 lbs. (2178 N)	ASTM D4851
	Weft: 235 lbs. (2086 N)	ASTM D4851
Tongue Tear:	Warp: 110 lbs. (488 N)	ASTM D2261
	Weft: 100 lbs. (444 N)	ASTM D2261
Trapezoidal Tear:	Warp: 95 lbs. (422 N)	ASTM D4533
	Weft: 90 lbs. (400 N)	ASTM D4533
Mullen Burst:	655 psi (4512 kPa)	ASTM D3786
Cold Crack:	Minus 60° C	ASTM D2136

Non-FR Fabric Fire Ratings

Test / Standard	Flame Spread	Smoke Developed	Char Length
ASTM E-84 (pass)	10	65	-----

SYNERGY NON-FR FABRIC



Colors may not be exactly as shown here. Contact your local BRITESPAN Dealer for actual fabric samples.

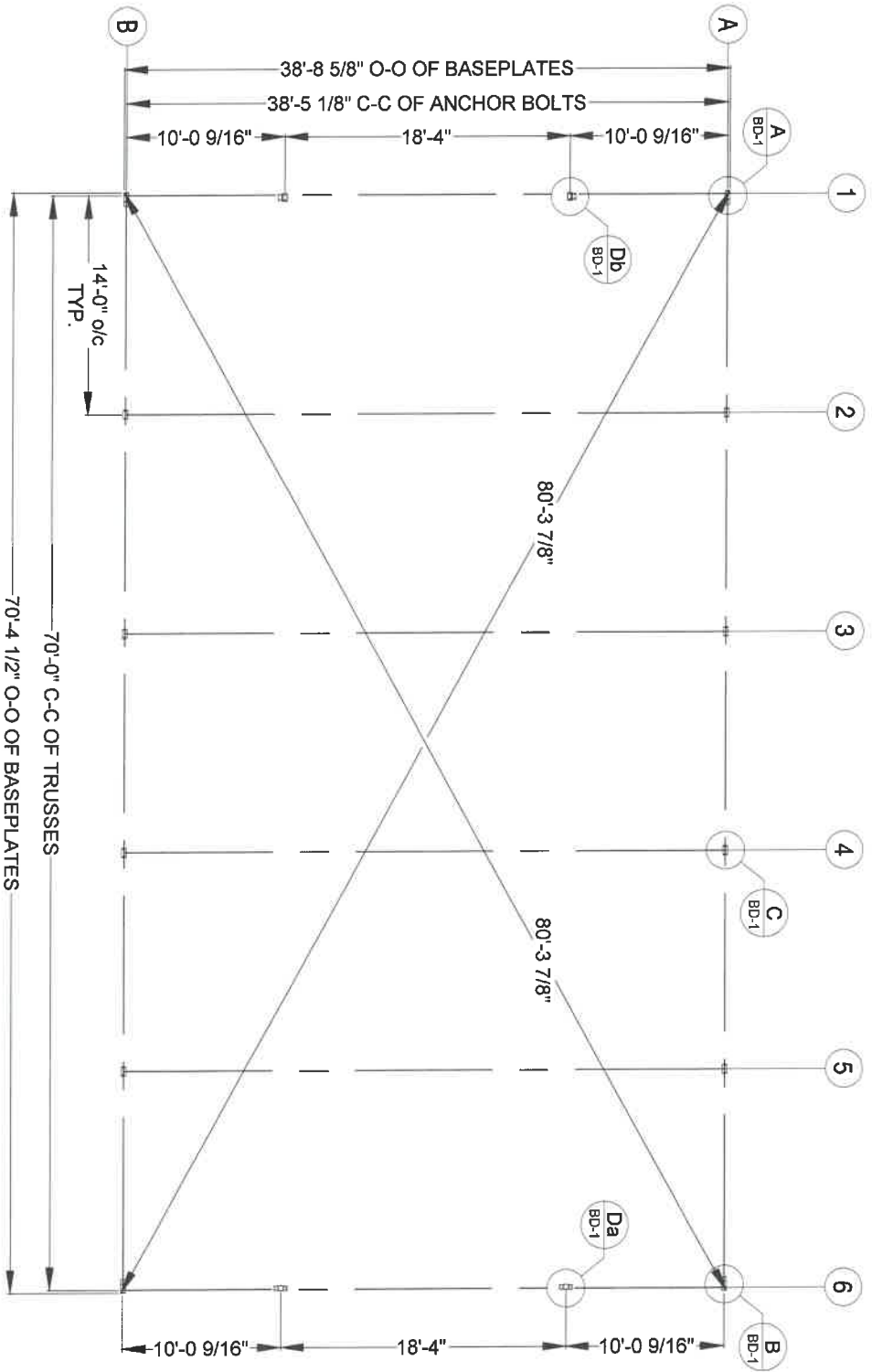

BRITESPAN
BUILDING SYSTEMS INC.

TF: 800-407-5846
www.britespanbuildings.com

THIS DRAWING IS PROPERTY OF BRITESPAN BUILDING SYSTEMS INC. ANY REPRODUCTION IN WHOLE OR IN PART WITHOUT THE EXPRESSED WRITTEN CONSENT OF BRITESPAN BUILDING SYSTEMS INC. IS PROHIBITED. THIS DRAWING IS NOT TO SCALE UNLESS OTHERWISE NOTED.

DRAWN BY: TWF
CHECKED BY: CJM

REV #	CR #	DESCRIPTION:	DATE:
0		ISSUED FOR CONSTRUCTION	02AUG.2019

DEALER: COVER-ALL BUILDINGS OF WV INC.
P.O. BOX 727
BRIDGEPORT, WV, 26330

PROJECT: ATLAS 18
40' X 70' - 320 GM
14' OC

ORDER ID: SO# 6855-01
WIDTH-HETU/FAHRES/ASSPROF: 40-320-220-18-11

CUSTOMER: WV DIVISION OF HIGHWAYS
BURNSVILLE HOTTS RT. 1 BOX 435
BURNSVILLE, WV, 26335

DRAWING TITLE: BASEPLATE LAYOUT
SHEET NO.: FB-2
PAGE NO.: 002 / 13

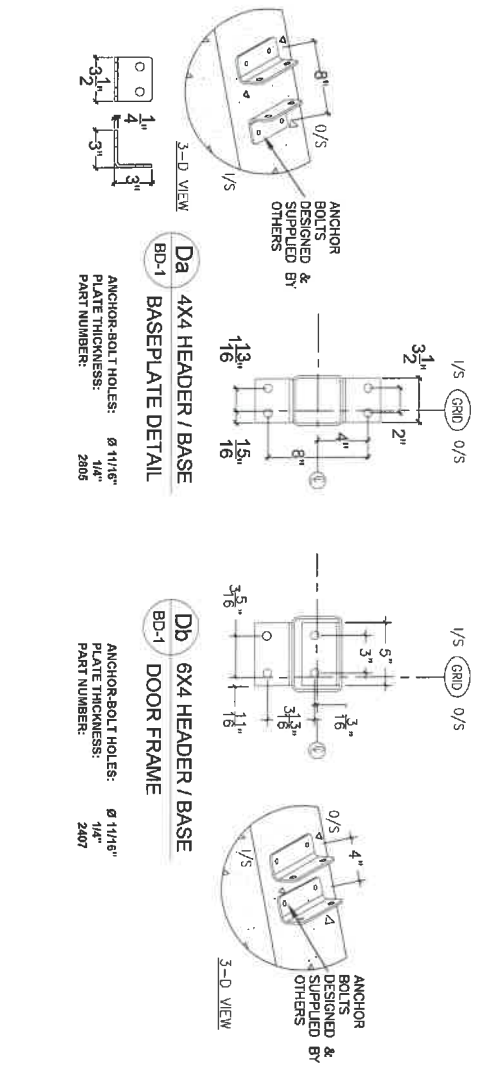
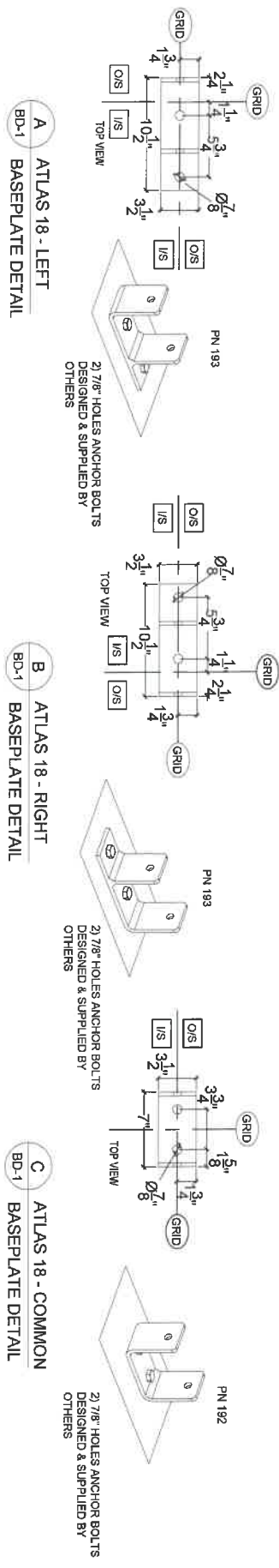

FOUNDATION DESIGNED & SUPPLIED BY OTHERS

		REV # CR # 0	DESCRIPTION: ISSUED FOR CONSTRUCTION	DATE: 02.AUG.2018	DEALER: COVER-ALL BUILDINGS OF WV INC. P.O. BOX 727 BRIDGEPORT, WV, 26330	ORDER ID: SO# 6895-01 WIDTH/STEEL-F49-HS-4830R	DRAWING TITLE: BASEPLATE DETAILS	PAGE NO.: 003 / 13
THIS DRAWING IS PROPERTY OF BRITESPAN BUILDING SYSTEMS INC. ANY REPRODUCTION, WHOLE OR IN PART WITHOUT THE EXPRESSED WRITTEN CONSENT OF BRITESPAN BUILDING SYSTEMS INC. IS PROHIBITED. THIS DRAWING IS NOT TO SCALE UNLESS OTHERWISE NOTED.		DRAWN BY: TWF	CHECKED BY: CJM	TF: 800-467-5846 www.britespanbuildings.com	CUSTOMER: WV DIVISION OF HIGHWAYS BURNSVILLE HQTS RT 1 BOX 435 BURNSVILLE, WV, 26335	PROJECT: ATLAS 18 40' X 70' - 320 GM 14' OC	SHEET NO.: BD-1	BRITESPAN BUILDING SYSTEMS INC.

NOTE:
 BUILDING IS DESIGNED AS EXPOSED
 (Ce=0.9) AND PARTIALLY ENCLOSED

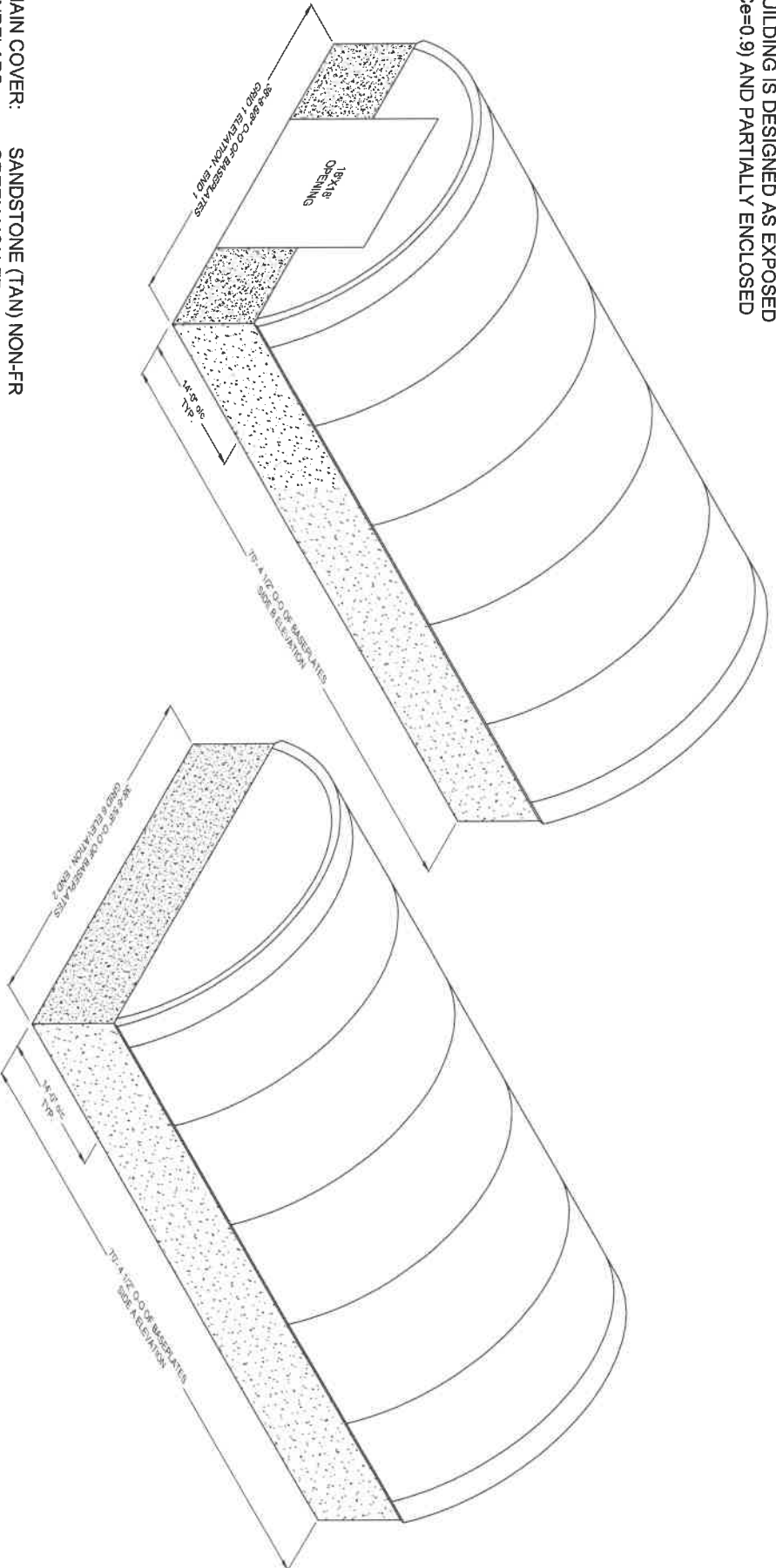

MAIN COVER: SANDSTONE (TAN) NON-FR
 ENDFLAPS: GREEN NON-FR
 ENDWALL(S): SANDSTONE (TAN) NON-FR

FOUNDATION DESIGNED
 & SUPPLIED BY OTHERS

		T: 800-407-5946 www.britespanbuildings.com	
THIS DRAWING IS PROPERTY OF BRITESPAN BUILDING SYSTEMS INC. ANY REPRODUCTION IN WHOLE OR IN PART WITHOUT THE WRITTEN CONSENT OF BRITESPAN BUILDING SYSTEMS INC. IS PROHIBITED. THIS DRAWING IS NOT TO SCALE UNLESS OTHERWISE NOTED.	DRAWN BY: TWF	CHECKED BY: CJM	
REV #	CR #	DESCRIPTION	DATE
0		ISSUED FOR CONSTRUCTION	02 AUG 2018
DEALER: COVER-ALL BUILDINGS OF WV, INC. P.O. BOX 727 BRIDGEPORT, WV, 26330		ORDER ID: SQ# 6855-01 WIDTH-STEEL-FAB-MSH-HSSBRCP: 40-320-220-18-//	CUSTOMER: WV DIVISION OF HIGHWAYS BURNSVILLE HOTTS RT. 1 BOX 435 BURNSVILLE, WV, 26335
PROJECT: ATLAS 18 40' X 70' - 320 GM 14' OC		DRAWING TITLE: PROJECT LAYOUT	PAGE NO.: 004 / 13

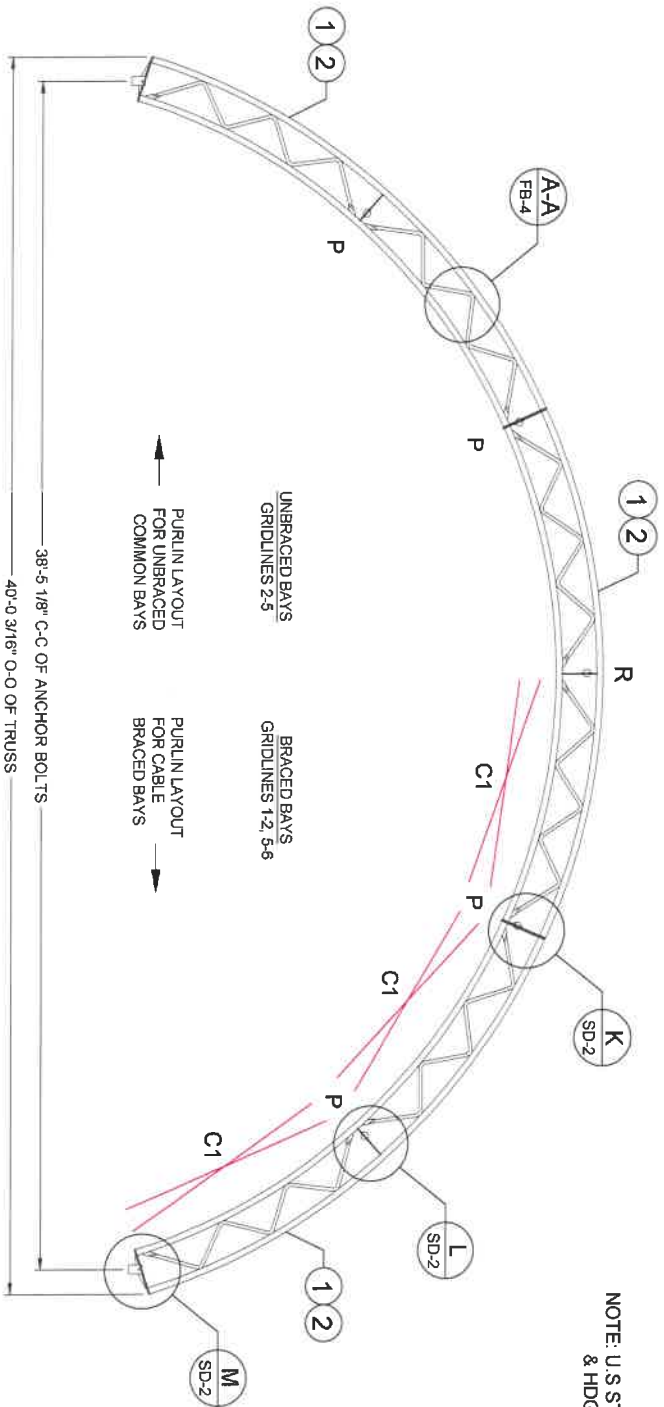

NOTE: U.S. STEEL CONTENT & HDG FASTENERS

ATLAS 18 - 40' WIDE

ZERO-TO-ZERO OF BASE PLATES = 84'-4 1/16"
 ASSEMBLED TRUSS WEIGHT W/ BASEPLATES ~ 350 lbs (each)

CABLE LEGEND	
ITEM	DESCRIPTION
	CROSS CABLE 5/16"
BRACING LEGEND	
ITEM	DESCRIPTION
X	CROSS CABLE 5/16"
P	PURLIN - 2-7/8" DIA. X 14 GA
P1	PURLIN - 2-7/8" DIA. X 14 GA

TRUSS COMPONENTS FOR ATLAS 18 - 40' GM			
LOCATION	ITEM #	PART #	QTY.
INTERIOR	1	104	3
END	2	105	3

ATLAS 18	14' BAY
40' GM	ITEM #
C1 CABLE	861200-9
	LENGTH
	200"

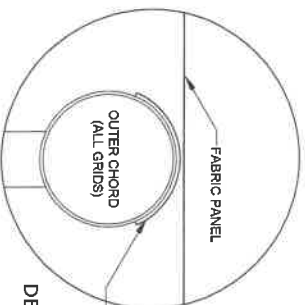

TERMA TAPE - APPLY GROUND TO GROUND, APPLY ON TOP OF COUPLER PROTECTORS

BRITESPAN BUILDING SYSTEMS INC. REPRODUCING THIS DRAWING WITHOUT THE EXPRESSED WRITTEN CONSENT OF BRITESPAN BUILDING SYSTEMS INC. IS PROHIBITED. THIS DRAWING IS NOT TO SCALE UNLESS OTHERWISE NOTED.

TE: 800-407-4846
www.britespanbuildings.com

PRM: TWV
CHK: CJM

REV #	CR #	DESCRIPTION:	DATE:
0		ISSUED FOR CONSTRUCTION	02.AUG.2016

DEALER: COVER-ALL BUILDINGS OF WV, INC.
 P.O. BOX 727
 BRIDGEPORT, WV, 26330

CUSTOMER: WV DIVISION OF HIGHWAYS
 BURNSVILLE HQS RT 1 BOX 435
 BURNSVILLE, WV, 26335

PROJECT: ATLAS 18
 40' X 70' - 320 GM
 14' OC

ORDER ID: SO# 6855-01
 WIDTH: 320'-220'-18'-1/2"

DRAWING TITLE: PURLIN & X-CABLE LAYOUT
 SHEET NO.: FB-4
 PAGE NO.: 005 / 13

NOTE: U.S STEEL CONTENT & HDG FASTENERS

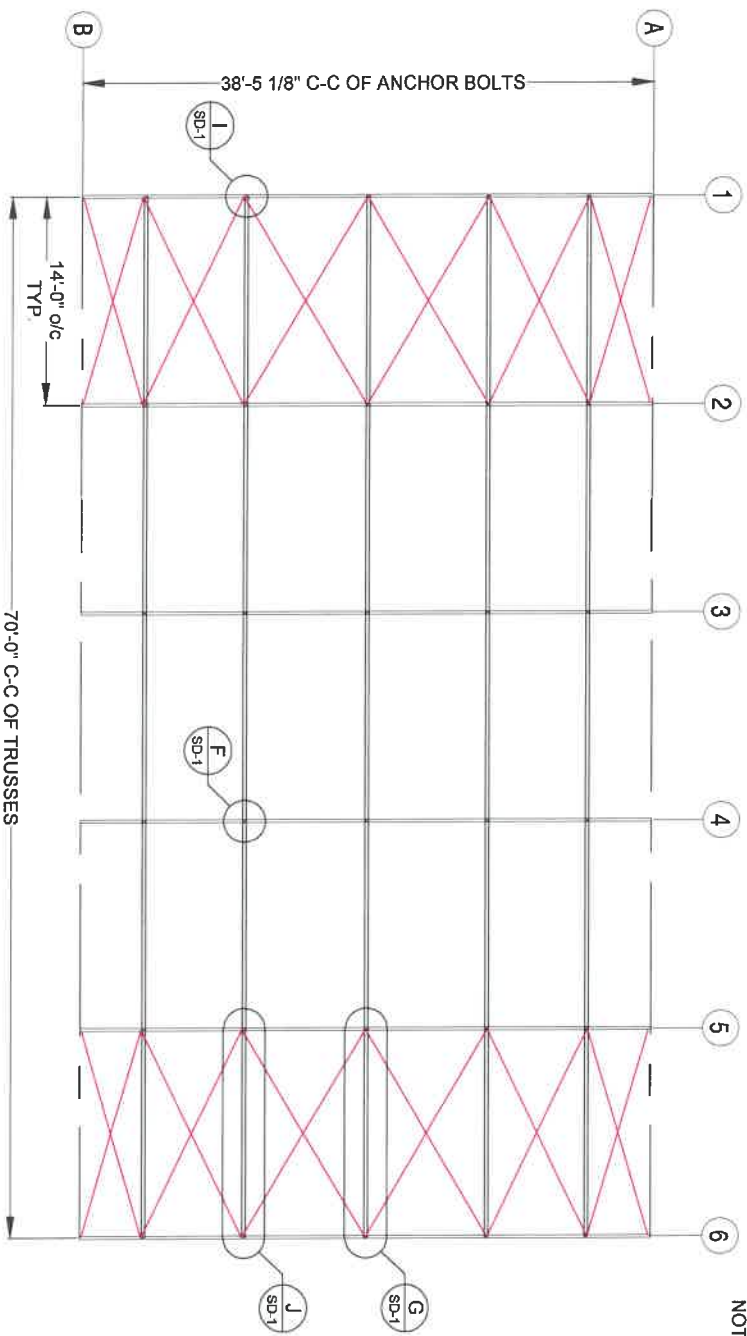

PLAN VIEW

FOR PURLIN DETAILS SEE: SD-1
FOR CABLE DETAILS SEE: SD-2

ITEM	DESCRIPTION
ALL BAYS - PURLINS - 2 7/8" DIA. X 14 GA.	
ITEM	DESCRIPTION
CROSS CABLE 5/16"	

TF: 800-407-4848
www.britespanbuildings.com

REV # 0 CR # 0

DESCRIPTION ISSUED FOR CONSTRUCTION

DATE 02.AUG.2019

DEALER: COVER-ALL BUILDINGS OF WV INC.
P.O. BOX 727
BRIDGEPORT, WV, 26330

CUSTOMER: WV DIVISION OF HIGHWAYS
BURNSVILLE HQTS RT. 1 BOX 435
BURNSVILLE, WV, 26335

PROJECT: ATLAS 18
40' X 70' - 320 GM
14' OC

ORDER ID: SO# 6855-01
WDRTR: STEEL-FABRHS-HSRORCP
40-320-220-18-//

DRAWN BY: TW/F
CHECKED BY: CJM

DRAWING TITLE: BRACING LAYOUT - PLAN VIEW
SHEET NO.: FB-5
PAGE NO.: 006 / 13

THIS DRAWING IS PROPERTY OF BRITESPAN BUILDING SYSTEMS INC. ANY REPRODUCTION IN WHOLE OR IN PART WITHOUT THE EXPRESSED WRITTEN CONSENT OF BRITESPAN BUILDING SYSTEMS INC. IS PROHIBITED. THIS DRAWING IS NOT TO SCALE UNLESS OTHERWISE NOTED.

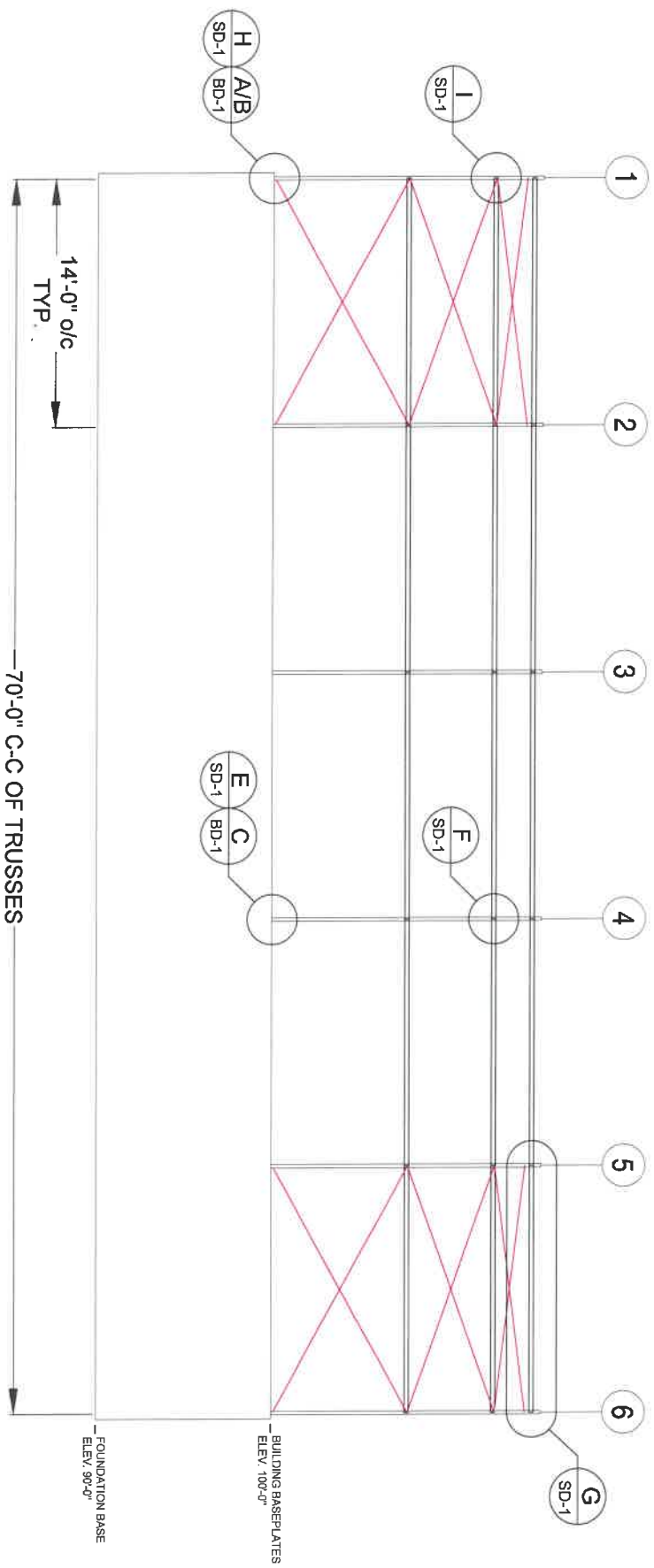

NOTE: U.S. STEEL CONTENT
& HDG FASTENERS

FOR PURLIN DETAILS SEE: SD-1
FOR CABLE DETAILS SEE: SD-2

ELEVATION

ITEM	PURLIN LEGEND	DESCRIPTION
ALL BAYS	PURLIN	- 2 7/8" DIA. X 14 GA
ITEM	CABLE LEGEND	DESCRIPTION
CROSS CABLE	5/16"	

BRITESPAN BUILDING SYSTEMS INC.
 TEL: 800-407-5946
 WWW.BRITESPANSYSTEMS.COM

REV # CR # DESCRIPTION: ISSUED FOR CONSTRUCTION DATE: 02AUG2019

DEALER: COVER-ALL BUILDINGS OF WV INC.
 P.O. BOX 727
 BRIDGEPORT WV, 26330

CUSTOMER: WV DIVISION OF HIGHWAYS
 BURNSVILLE HQTS RT 1 BOX 435
 BURNSVILLE, WV, 26335

PROJECT: ATLAS 18
 40' X 70' - 320 GM
 14 OC

ORDER ID: SO# 6855-01
 WOOD-STEEL-FAS-MS-AS-SC-CP-
 40-320-220-18-1/

DRAWING TITLE: BRACING LAYOUT - ELEVATION
 SHEET NO.: FB-6 PAGE NO.: 007 / 13

DRAWN BY: TWB
 CHECKED BY: CJM

THIS DRAWING IS PROPERTY OF BRITESPAN BUILDING SYSTEMS INC. ANY REPRODUCTION IN WHOLE OR IN PART WITHOUT THE EXPRESSED WRITTEN CONSENT OF BRITESPAN BUILDING SYSTEMS INC. IS PROHIBITED. THIS DRAWING IS NOT TO SCALE UNLESS OTHERWISE NOTED.

- NOTES:
- "H" DENOTES BLOCK WINCH & STRAP FOR FASTENING TUBE
 - EC VERTICAL LOCATION DIMENSIONS ARE TO THE CENTRELINE OF MEMBERS
 - FIELD DRILL HSS AS REQUIRED
 - FINAL FABRIC TERMINATION DESIGNED & SUPPLIED BY OTHERS FOR ALL APRONS

MARK #	QTY.	COMPONENTS (in)
EC-1	2	2408-HSS-VERTICAL-4" X 6" X 3/16"-3" CENTRES-136"
161	4	BRKT-6" DEEP HSS TOP SADDLE-2-3/8" CHORD
2407	12	HEADER/BASE ANGLE-4" X 6" HSS-3" CENTRES
HD-1	1	2409-HSS-HEADER-4" X 6" X 3/16"-3" CENTRES-215"
HD-2	2	2409-HSS-HEADER-4" X 6" X 3/16"-3" CENTRES-120"

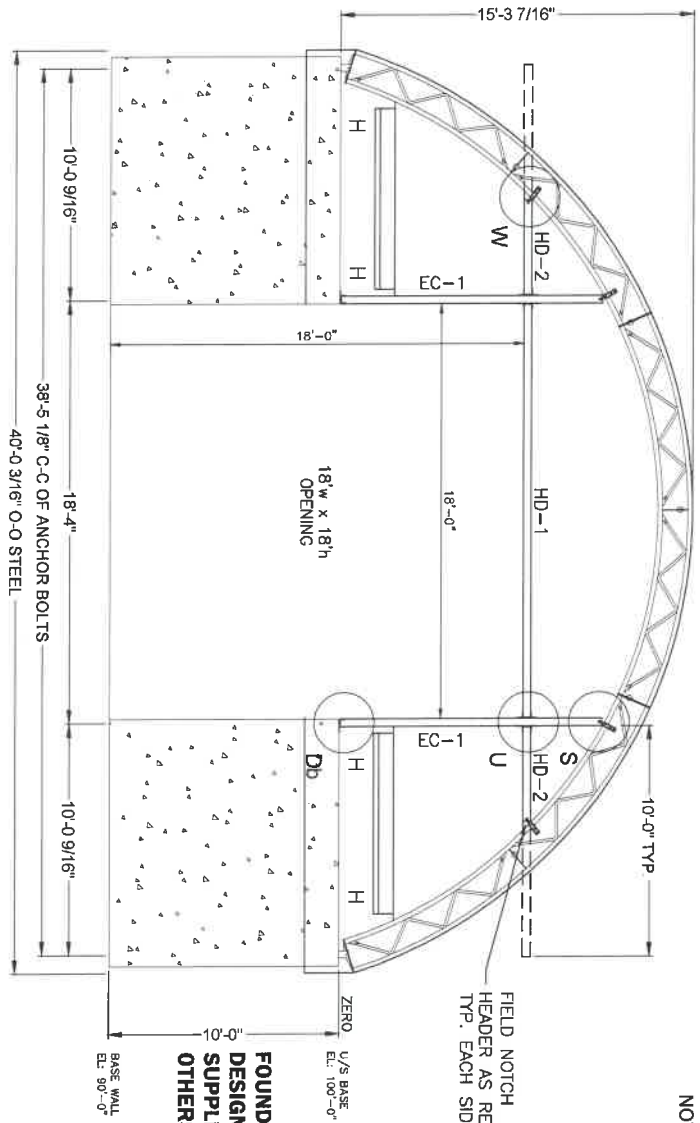
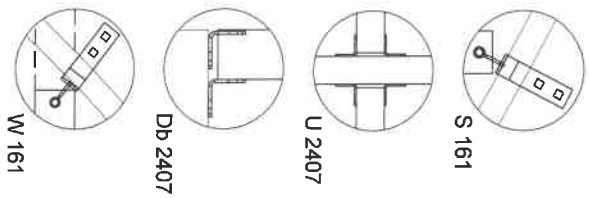

NOTE: U.S STEEL CONTENT & HDG FASTENERS

FOUNDATION DESIGNED & SUPPLIED BY OTHERS

GRIDLINE 1 - END 1

Britespan
BUILDING SYSTEMS INC.

TF: 800-407-5946
www.britespanbuildings.com

THIS DRAWING IS PROPERTY OF BRITESPAN BUILDING SYSTEMS INC. ANY REPRODUCTION IN WHOLE OR IN PART WITHOUT THE EXPRESSED WRITTEN CONSENT OF BRITESPAN BUILDING SYSTEMS INC. IS PROHIBITED. THIS DRAWING IS NOT TO SCALE UNLESS OTHERWISE NOTED.

DRAWN BY: TWFF
CHECKED BY: CJM

REV #	CR #	DESCRIPTION:	DATE:
0		ISSUED FOR CONSTRUCTION	02.AUG.2019

DEALER: COVERALL BUILDINGS OF WV, INC.
P.O. BOX 727
BRIDGEPORT, WV, 26330

CUSTOMER: WV DIVISION OF HIGHWAYS
BURNSVILLE HQTS RT 1 BOX 435
BURNSVILLE, WV, 26335

PROJECT:	ORDER ID:	DRAWING TITLE:
ATLAS 18 40' X 70' - 320 GM 14' OC	SO# 6855-01 WIDTH-STEEL-FAB-HSS-HSSRORP- 40-320-220-18-//	ENDWALL 1 LAYOUT

PAGE NO.:
008 /13

- NOTES:
1. "H" DENOTES BLOCK WINCH & STRAP FOR FASTENING TUBE
 2. EC VERTICAL LOCATION DIMENSIONS ARE TO THE CENTRELINE OF MEMBERS
 3. FIELD DRILL HSS AS REQUIRED
 4. FIELD CUT CEE CHANNEL AS REQUIRED

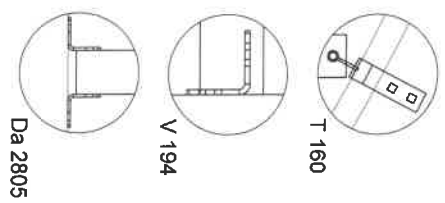

MARK #	QTY.	COMPONENTS (in)
EC-1	2	1518-HSS-VERTICAL-4" X 4" X 1/8" - 2" CENTRES - 136"
160	2	BRKT-4" DEEP HSS TOP SADDLE-2-3/8" CHORD
2805	4	HEADER/BASE ANGLE-4" X 4" HSS - 2" CENTRES
HZ-1/201	2	1538-240-CEE CHANNEL 6" - 14 ga - 240"/6096mm
HZ-1/200	1	1538-180-CEE CHANNEL 6" - 14 ga - 180"/4572mm
194	8	BRKT - CEE CHANNEL ANGLE

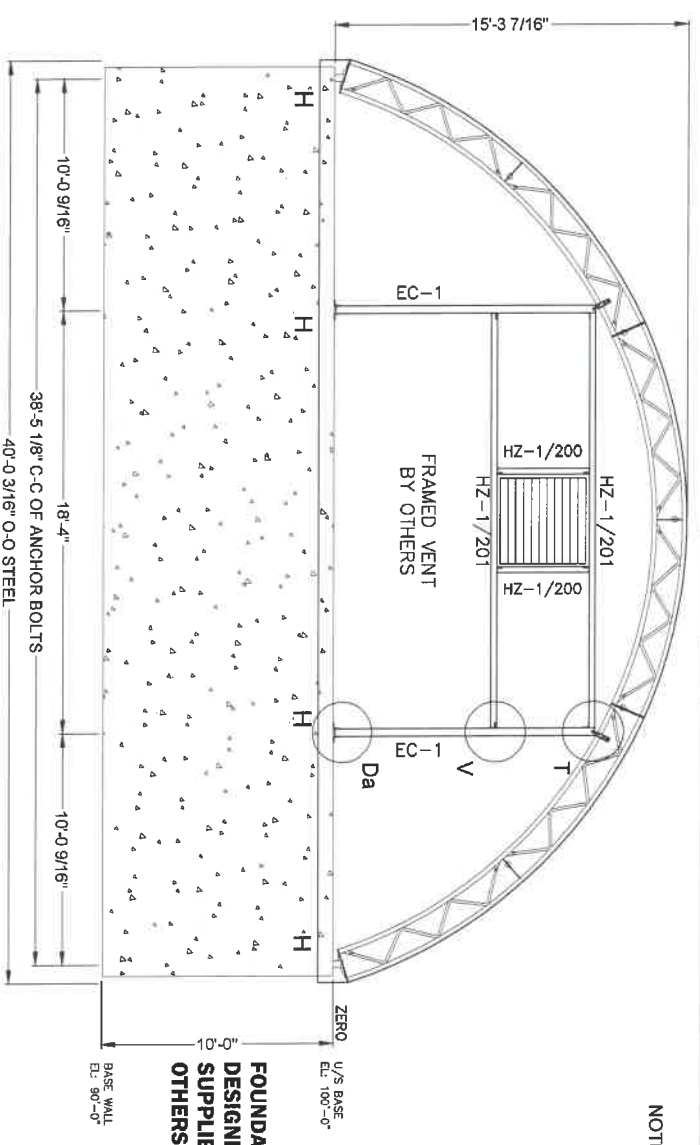

NOTE: U.S STEEL CONTENT & HDG FASTENERS

GRIDLINE 6 - END 2

TF: 800-407-8846
www.britespanbuildings.com

THIS DRAWING IS PROPERTY OF BRITESPAN BUILDING SYSTEMS INC. ANY REPRODUCTION IN WHOLE OR IN PART WITHOUT THE EXPRESSED WRITTEN CONSENT OF BRITESPAN BUILDING SYSTEMS INC. IS PROHIBITED. THIS DRAWING IS NOT TO SCALE UNLESS OTHERWISE NOTED.

DRAWN BY: TWJ
CHECKED BY: CJM

REV.#	CR.#	DESCRIPTION	DATE
0		ISSUED FOR CONSTRUCTION	02.AUG.2019

DEALER: COVER-ALL BUILDINGS OF W/ INC.
P.O. BOX 727
BRIDGEPORT, WV, 26330

CUSTOMER: W/ DIVISION OF HIGHWAYS
BURNSVILLE HQTS R1.1 BOX 435
BURNSVILLE, WV, 26335

PROJECT:	ORDER ID:	DRAWING TITLE:
ATLAS 18 40' X 70' - 320 GM 14' OC	SO# 6855-01 WIDTH-STEEL-FAD-HSS-HSSRCP 40-320-220-18-//	ENDWALL 2 LAYOUT

PAGE NO.:
EW-2

PAGE NO.: 009 /13

NOTE: U.S STEEL CONTENT
& HDG FASTENERS

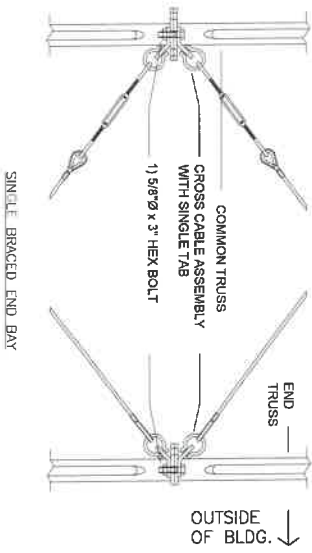

K CROSS CABLES AT DOGBONE
SD-2 CONNECTION DETAILS

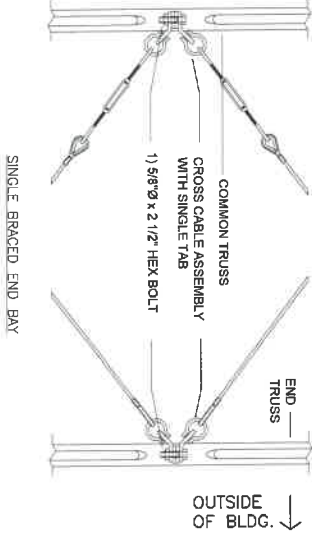

L CROSS CABLES AT KINGPIN
SD-2 CONNECTION DETAILS

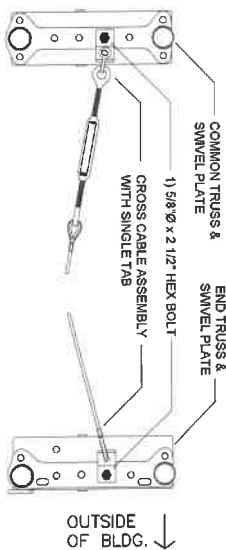

M CROSS CABLES AT SWIVEL PLATE
SD-2 CONNECTION DETAILS

		REV # CR # 0		DESCRIPTION: ISSUED FOR CONSTRUCTION		DATE: 02/JUN/2019		DEALER: COVER-ALL BUILDINGS OF WW, INC. P.O. BOX 727 BRIDGEPORT, WV, 26330		CUSTOMER: WW DIVISION OF HIGHWAYS BURNSVILLE HOTTS RT.1 BOX 435 BURNSVILLE, WV, 26335	
THIS DRAWING IS PROPERTY OF BRITESPAN BUILDING SYSTEMS, INC. ANY REPRODUCTION IN WHOLE OR IN PART WITHOUT THE EXPRESSED WRITTEN CONSENT OF BRITESPAN BUILDING SYSTEMS, INC. IS PROHIBITED. THIS DRAWING IS NOT TO SCALE UNLESS OTHERWISE NOTED.		DRAWN BY: TWF		PROJECT: ATLAS 18 40' x 70' - 320 GM 14' OC		ORDER ID: SQ# 6885-01		DRAWING TITLE: STANDARD DETAILS 2		PAGE NO.: 011 / 13	
BRITESPAN BUILDING SYSTEMS, INC. TEL: 800-407-6946 www.britespanbuildings.com		CHECKED BY: CJM		WIDTH-STEEL-PARISH-HSSDRCP-		SHEET NO.: SD-2		WIDTH-STEEL-PARISH-HSSDRCP-		SHEET NO.: SD-2	

NOTE: U.S. STEEL CONTENT & HDG FASTENERS

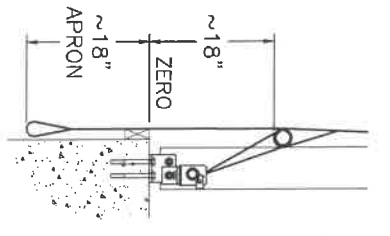

N ENDWALL #1 TERMINATION
SD-3 CONNECTION DETAIL

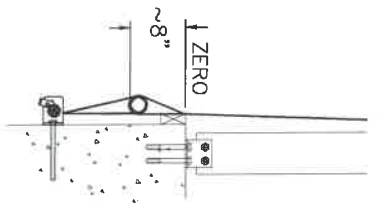

O ENDWALL #2 TERMINATION
SD-3 CONNECTION DETAIL

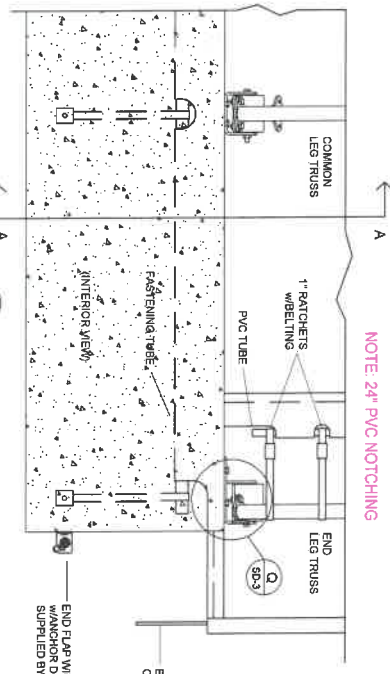

P 220 STANDARD COVER
SD-3 CONNECTION DETAIL

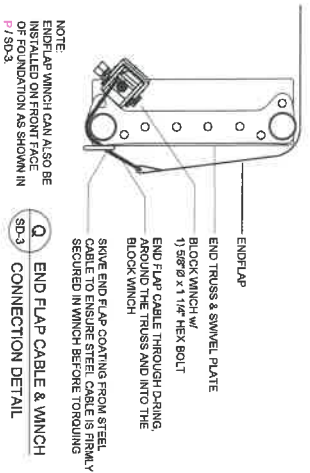

Q END FLAP CABLE & WINCH
CONNECTION DETAIL

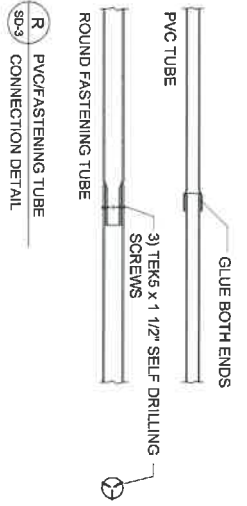

R PVC/FASTENING TUBE
CONNECTION DETAIL

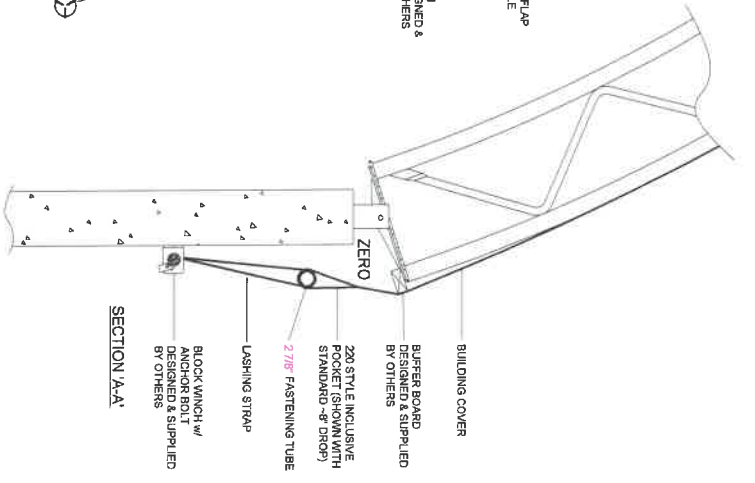

SECTION A-A

BRITESPAN BUILDING SYSTEMS INC.
 TEL: 800-407-5846
 WWW.BRITESPANBUILDINGS.COM

DEALER:
 COVER-ALL BUILDINGS OF WV, INC.
 P.O. BOX 727
 BRIDGEPORT, WV, 26330

CUSTOMER:
 WV DIVISION OF HIGHWAYS
 BURNSVILLE HQT'S RT. 1 BOX 435
 BURNSVILLE, WV, 26335

REV #	CR #	DESCRIPTION:	DATE:
0		ISSUED FOR CONSTRUCTION	02 AUG 2018

PROJECT:
 ATLAS 18
 40 x 70' - 320 GM
 14 OC

ORDER ID:
 SO# 6855-01
 WIDTH-STEEL-FAC-HSS-HSS-RMP-
 40-320-220-18-//

DRAWN BY:
 TWF

CHECKED BY:
 CJM

DRAWING TITLE:
 STANDARD DETAILS 3

SHEET NO.:
 SD-3

PAGE NO.:
 012 / 13

THIS DRAWING IS PROPERTY OF BRITESPAN BUILDING SYSTEMS INC. ANY REPRODUCTION IN WHOLE OR IN PART WITHOUT THE EXPRESSED WRITTEN CONSENT OF BRITESPAN BUILDING SYSTEMS INC. IS PROHIBITED. THIS DRAWING IS NOT TO SCALE UNLESS OTHERWISE NOTED.

NOTE: END FLAP WINCH CAN ALSO BE INSTALLED ON FRONT FACE OF FOUNDATION AS SHOWN IN P / SD-3

NOTE: END FLAP WINCH CAN ALSO BE INSTALLED ON FRONT FACE OF FOUNDATION AS SHOWN IN P / SD-3

NOTE: U.S STEEL CONTENT
& HDG FASTENERS

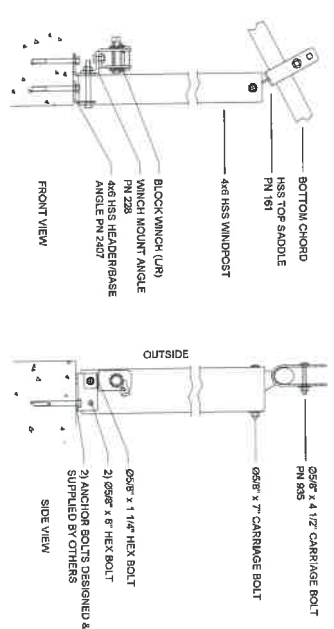

Db S 6x4 HSS WINDPOST - 2 3/8" CHORD
BD-1 ED-1 CONNECTION DETAILS

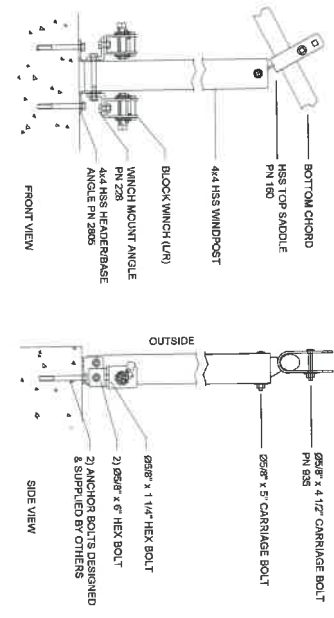

Da T 4x4 HSS WINDPOST - 2 3/8" CHORD
BD-1 ED-1 CONNECTION DETAILS

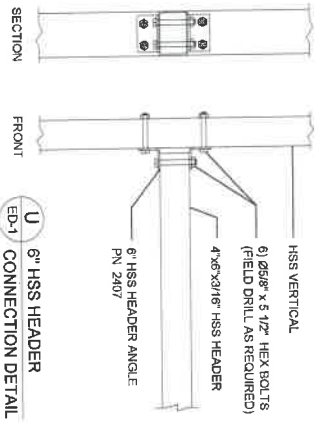

U 6" HSS HEADER
ED-1 CONNECTION DETAIL

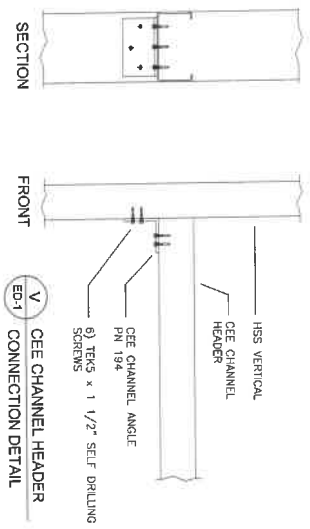

V CEE CHANNEL HEADER
ED-1 CONNECTION DETAIL

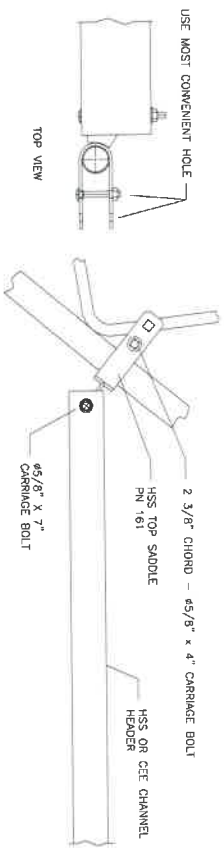

W HEADER / CEE CHANNEL TO TRUSS
ED-1 CONNECTION DETAIL

		THIS DRAWING IS PROPERTY OF BRITESPAN BUILDING SYSTEMS INC. ANY REPRODUCTION IN WHOLE OR IN PART WITHOUT THE EXPRESSED WRITTEN CONSENT OF BRITESPAN BUILDING SYSTEMS INC. IS PROHIBITED. THIS DRAWING IS NOT TO SCALE UNLESS OTHERWISE NOTED.	
DRAWN BY: TWF	CHECKED BY: CJM	REV # 0	CR #
TR: 800-447-5846 www.britespanbuildings.com	DESCRIPTION: ISSUED FOR CONSTRUCTION	DATE: 02.16.2019	PROJECT: COVER-ALL BUILDINGS OF WW INC. P.O. BOX 727 BRIDGEPORT, WV, 26330
ORDER ID: SQ# 6855-01	CUSTOMER: WW DIVISION OF HIGHWAYS BURNSVILLE HQ'S RT. 1 BOX 435 BURNSVILLE, WV, 26335	DRAWING TITLE: ENDWALL DETAILS	SHEET NO.: 013 / 13
PROJECT: ATLAS 18 40' x 70' - 320 GM 14' OC	ORDER ID: SQ# 6855-01 W/OT-S/TEL-748-HSS-HSS/NO-C	SHEET NO.: ED-1	PAGE NO.: 013 / 13

Certificate of Registration

This is to certify that CWB Registration has certified:



Plants: 688 Josephine Street North, RR1, Wingham, ON N0G 2W0
75 North Street West, Wingham, ON N0G 2W0 / 6 Kerr Crescent, Puslinch, ON N0B 1J0
Design Office: 688 Josephine Street North, RR1, Wingham, ON N0G 2W0

to the Certification Standard:

CSA A660-10

"Certification of Manufacturers of Steel Building Systems"

Initial Registration	Date of Issue	Date of Expiry	Certificate Number
September 24, 2010	January 15, 2021	September 24, 2021	OLYMP0
Scope: Design and manufacture steel building systems			



cwbregistration

Registrar



*Terms and Conditions governing registration and the use of this certificate are defined in the contract between CWB Registration and the Holder.
Contact the certificate holder for further information related to the scope and boundaries of the registration.*

A660 Cer / 2018-11

CWB Registration, 8260 Park Hill Drive, Milton, Ontario, Canada, L9T 5V7, Tel: 1-800-844-6790 / (905)-542-1312, Fax: (905) 542-1318, Web: www.cwbgroup.org

Britespan Building Systems Inc.



CONCRETE PIERS

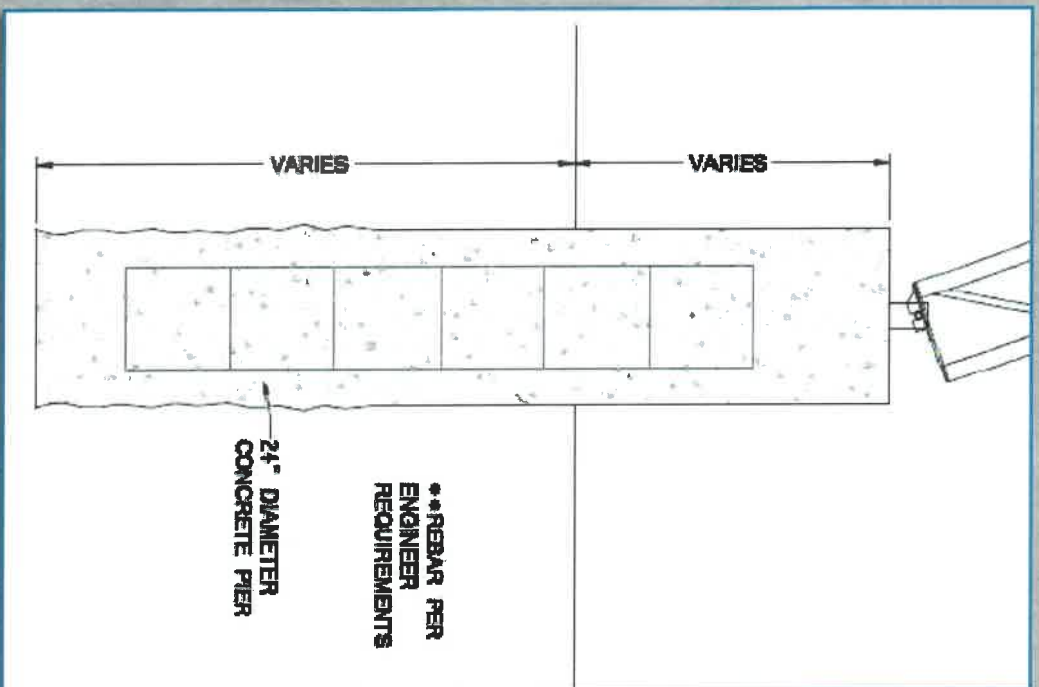

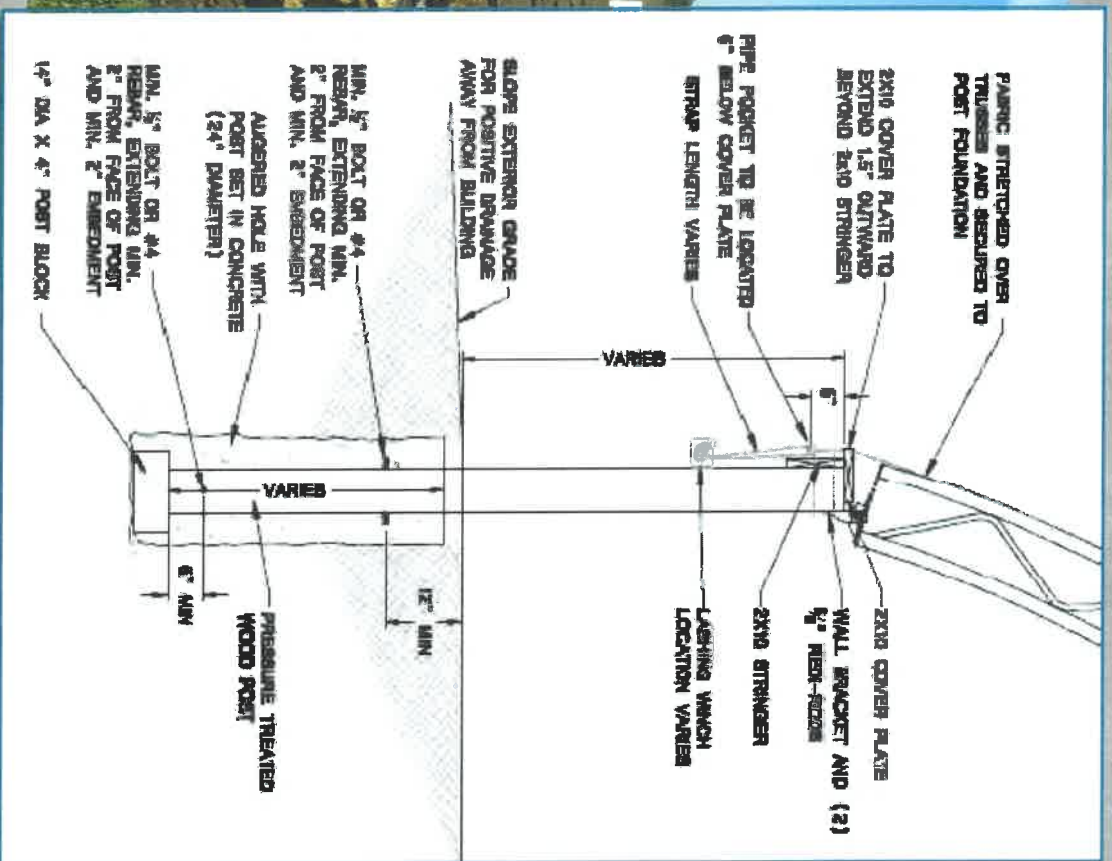

BRITESPAN
BUILDING SYSTEMS INC

POST MOUNT

POURED WALL

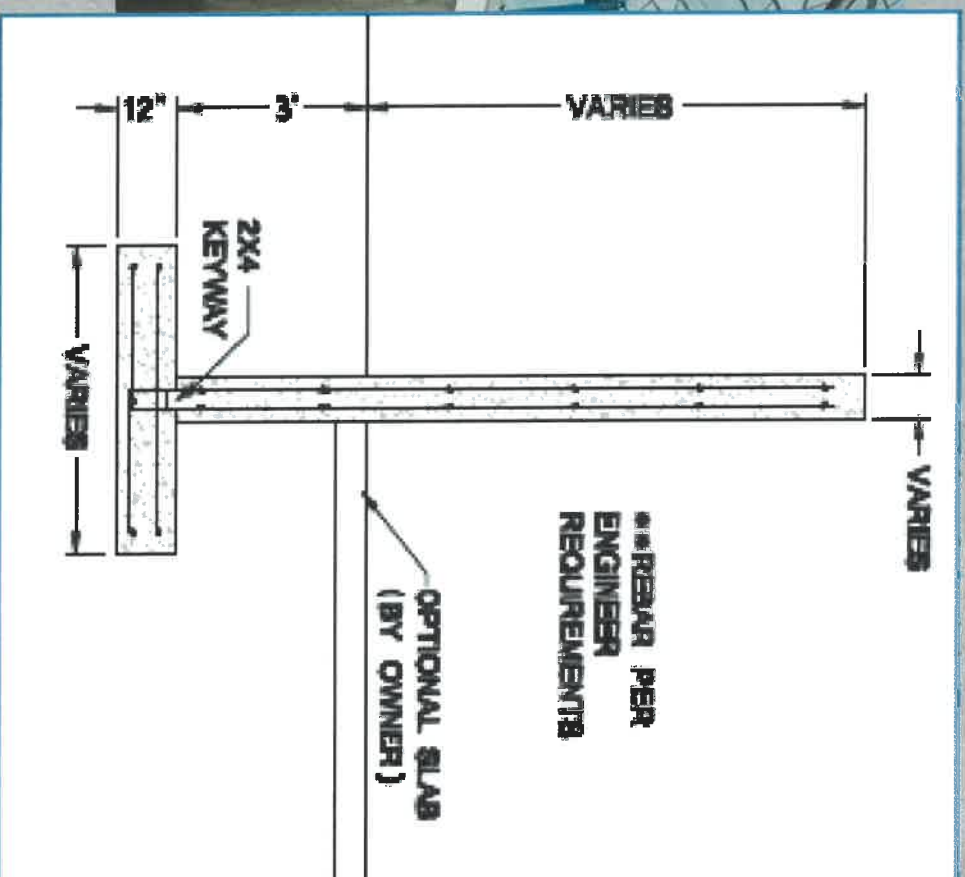

BRITESPAN™

BUILDING SYSTEMS INC.

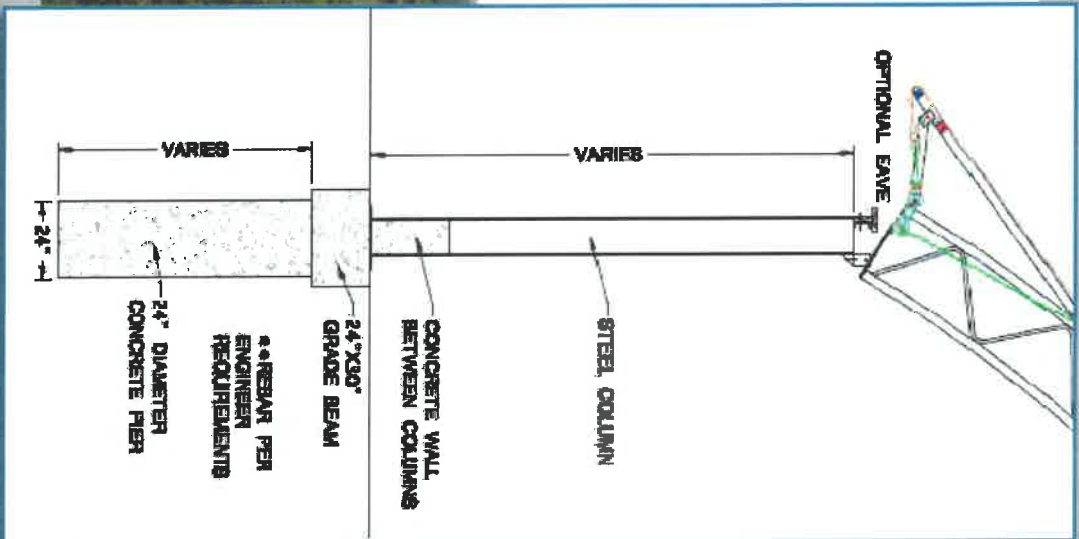

MEGA BLOCKS

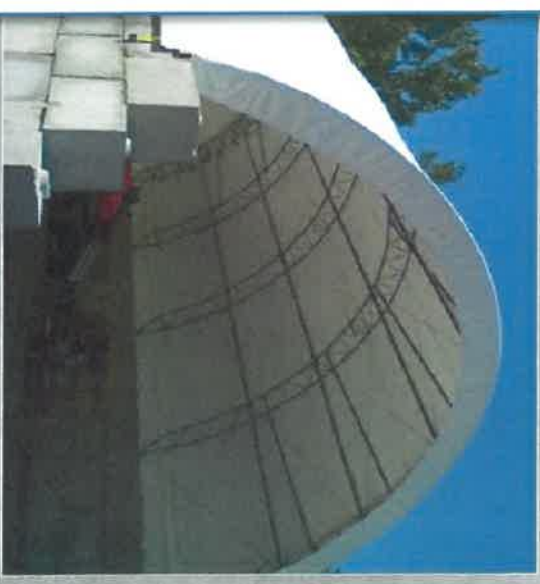
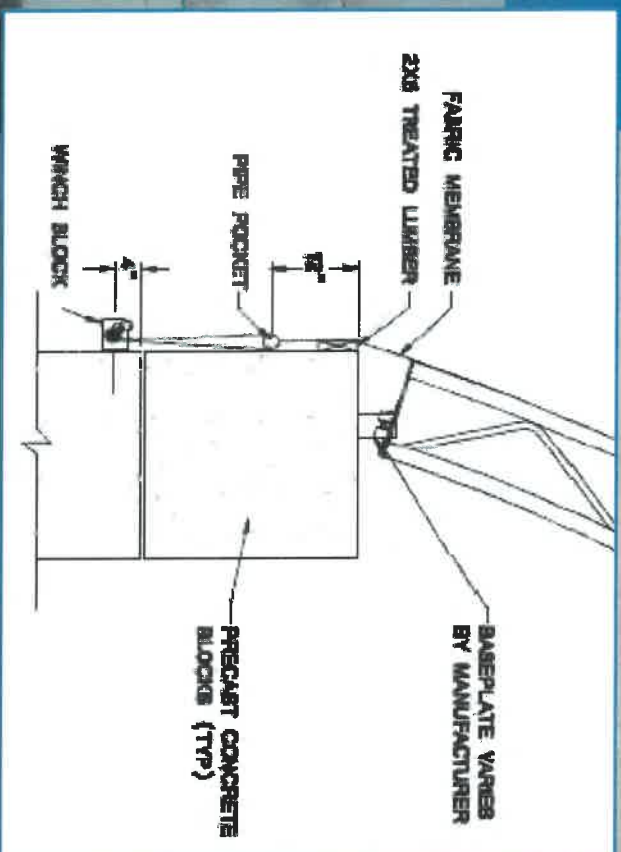
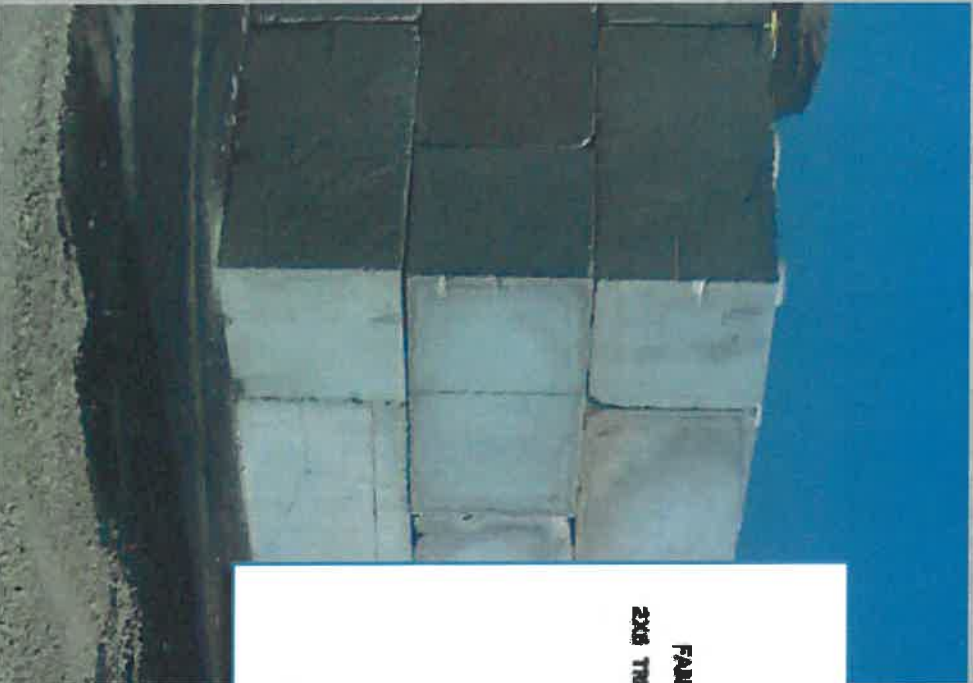

ENGINEERED T-PANEL

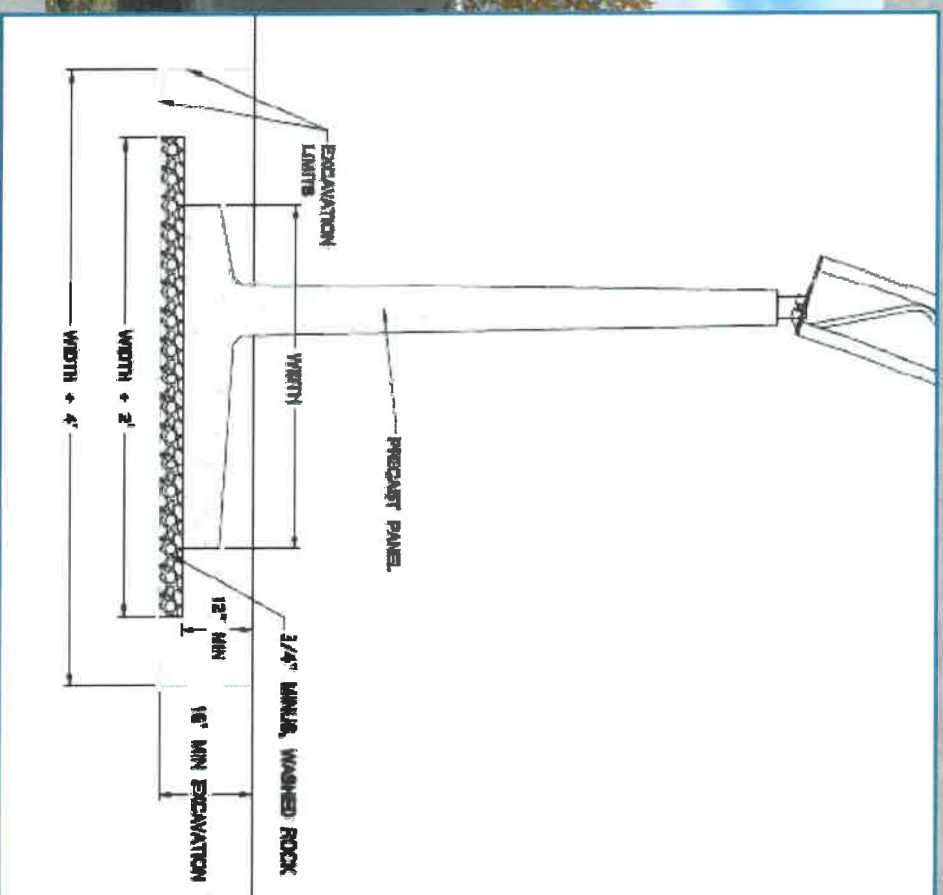

SHIPPING CONTAINERS

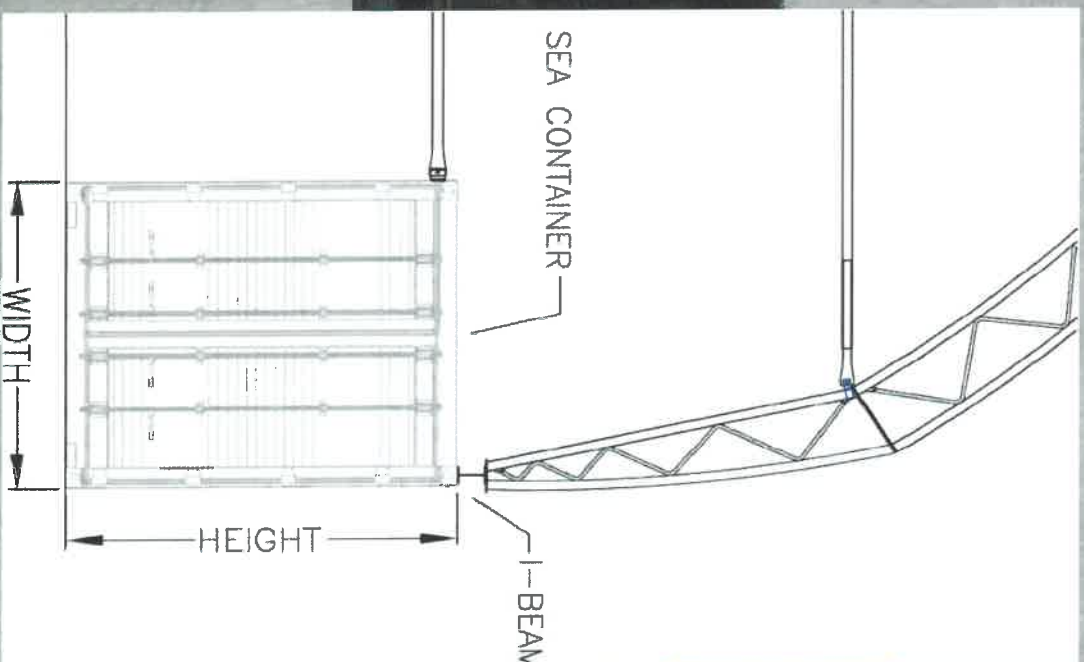

BASE RAIL SYSTEM

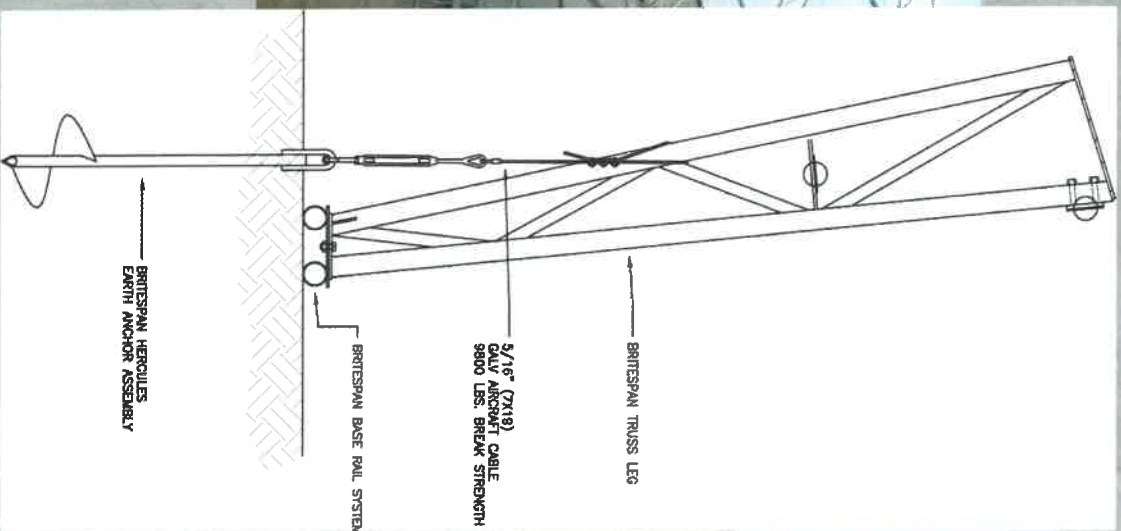

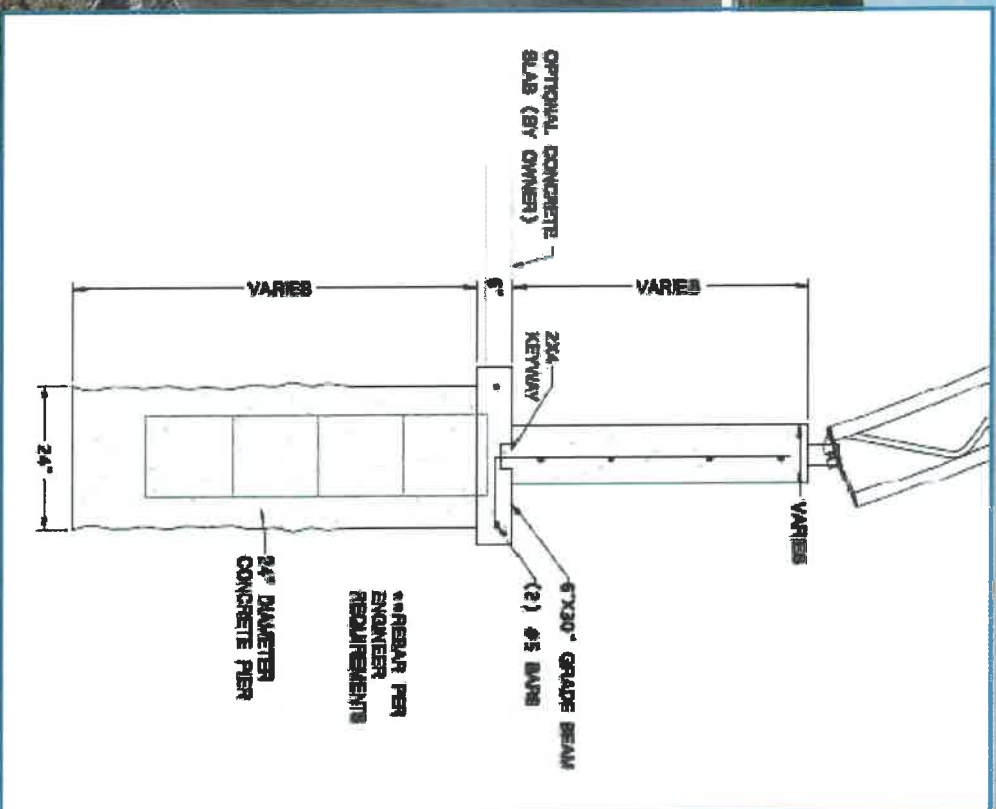

BRITESPAN™
BUILDING SYSTEMS INC.

PIER/GRADE BEAM

FLOATING SLAB

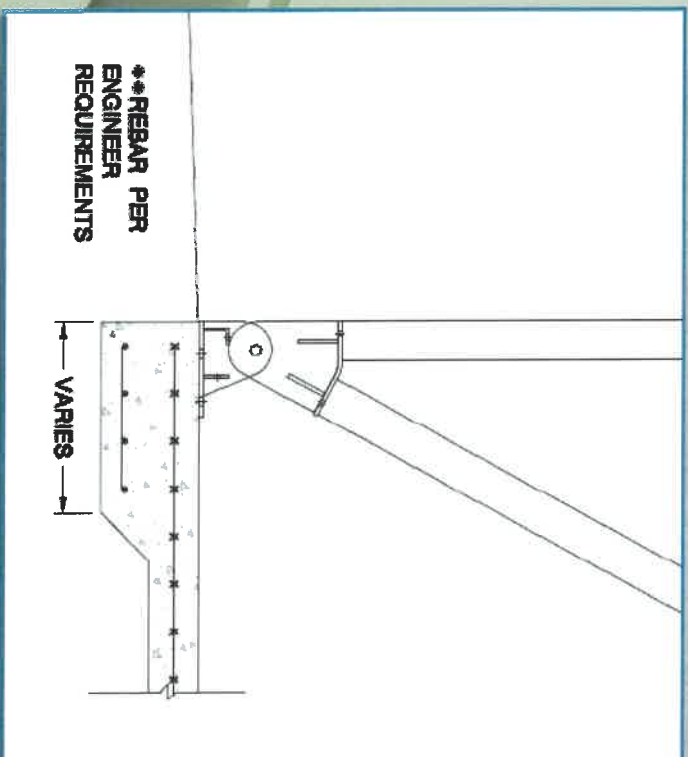

COVER TYPES

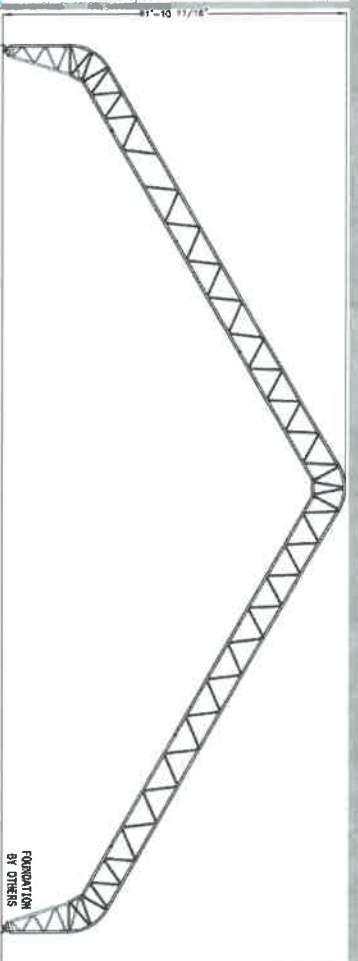
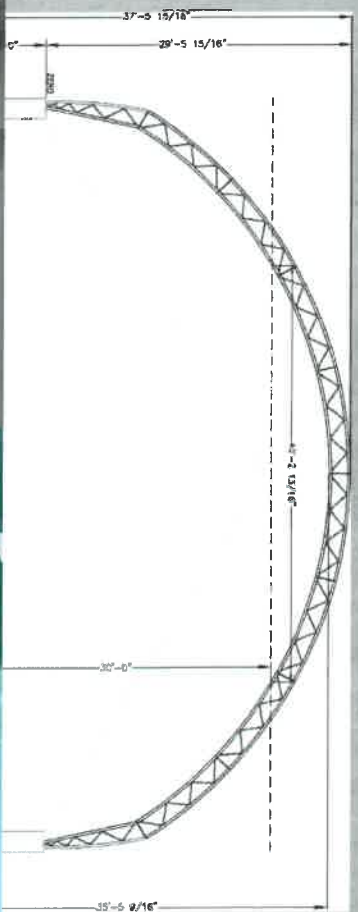

CONSTRUCTION
BY OTHERS



INSURABILITY

DON'T LET A COMPANY SELL YOU A BUILDING THAT DOES NOT COMPLY WITH THE BUILDING CODE JUST BECAUSE YOUR SITUATION DOES NOT MANDATE IT. MANY INSURANCE COMPANIES WILL SELL YOU A POLICY AND COLLECT YOUR PREMIUMS. THEN, WHEN THERE IS A CLAIM, THEY WILL REFUSE TO PAY IT IF THE BUILDING DOES NOT COMPLY WITH THE BUILDING CODE.

LIABILITY

YOU HAVE WORKED HARD FOR EVERYTHING YOU HAVE. WHY LOSE IT IF SOMETHING CATOSTROPHIC HAPPENS AND SOMEBODY IS INJURED OR KILLED. WOULD THAT BE WORTH THE FEW DOLLARS YOU MAY HAVE SAVED UP FRONT? JUST BECAUSE YOU DO NOT NEED TO BUY AN ENGINEERED BUILDING, SHOULD YOU?



BRITESPAN™
BUILDING SYSTEMS INC

DESIGNED OR ENGINEERED?

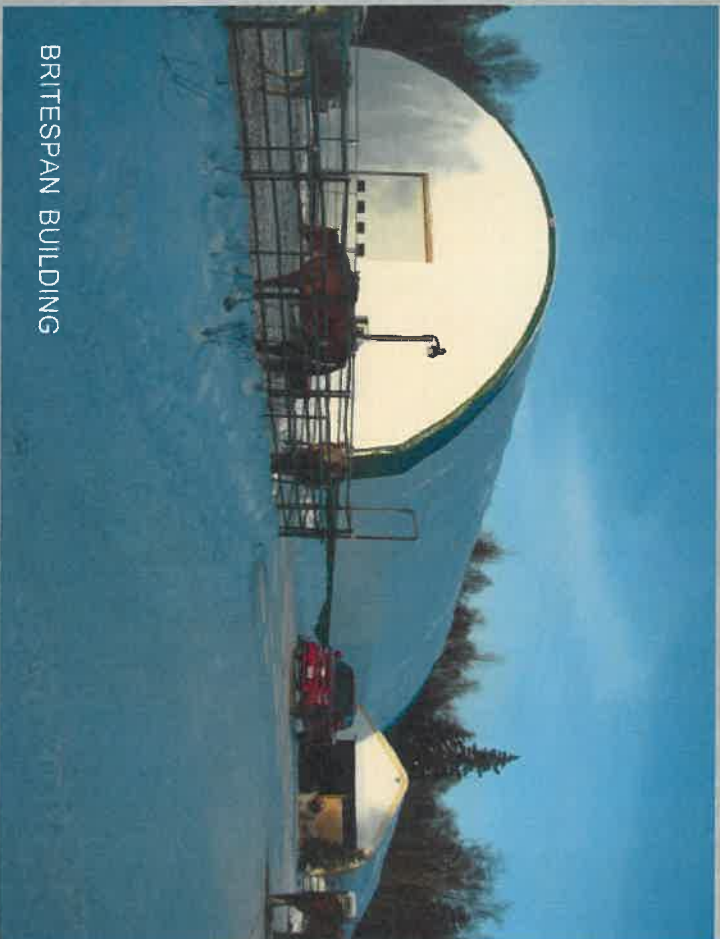

BRITESPAN BUILDING



COMPETITOR'S BUILDING

WHICH WOULD YOU PREFER?

ENGINEERED FOR THE SITE

OR DESIGNED FOR THE SITE

BRITESPAN
BUILDING SYSTEMS INC

SERVICE



WHICH WOULD YOU PREFER?

EXPERIENCED DEALER NETWORK OR COMPETITION'S CALL CENTER

BRITESPAN™
BUILDING SYSTEMS INC

GALVANIZING

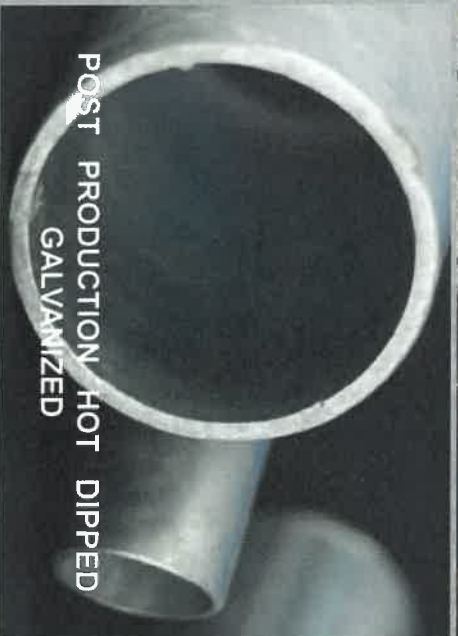

POST PRODUCTION HOT DIPPED GALVANIZED



COMPETITOR'S BUILDING



COMPETITOR'S BUILDING



IN-LINE OR TRIPLE COAT FINISH

ROUND OR SQUARE TUBING?

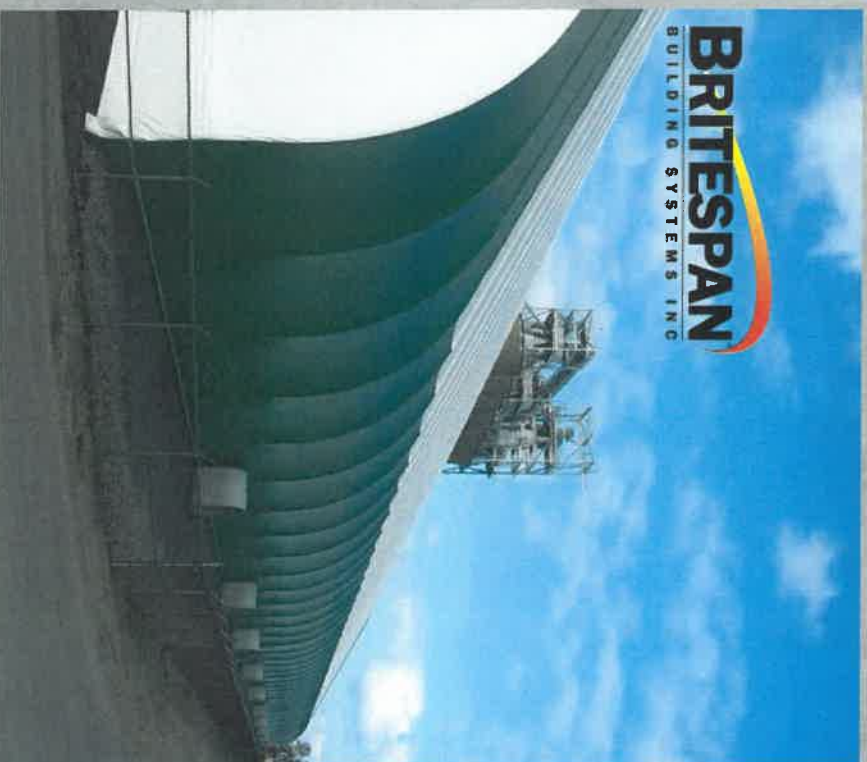

ROUND TUBING INCREASES THE
LIFE OF THE FABRIC AS THE EDGES
ARE BLUNT WHERE THE FABRIC RIDES

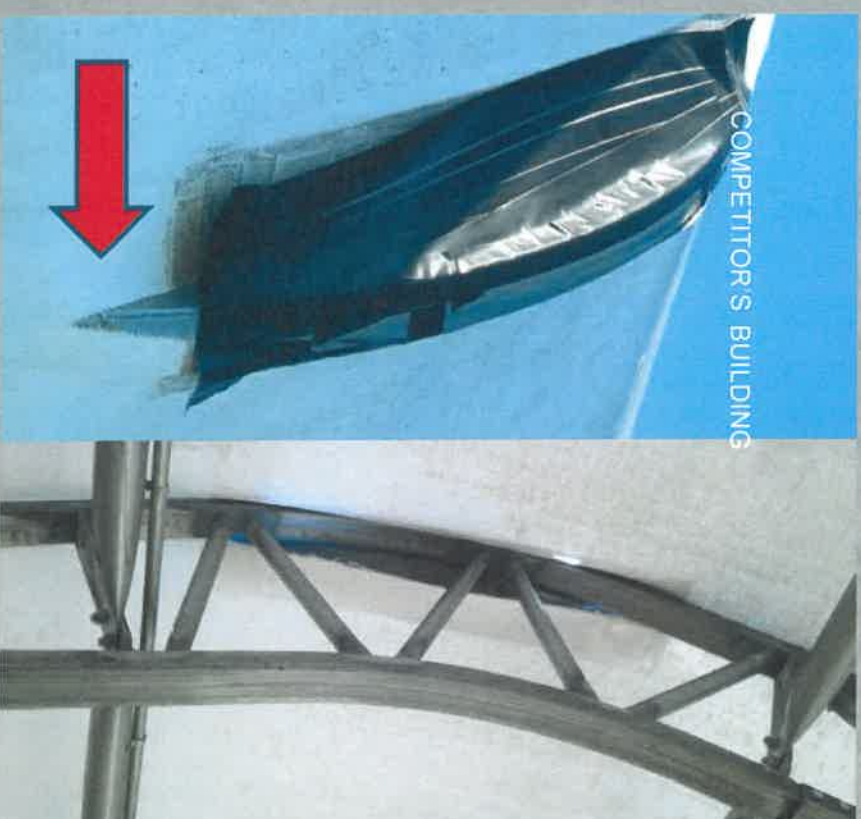

SQUARE TUBING ACTS LIKE A KNIFE
AND CUTS THROUGH THE FABRIC
UNDER TENSION

BRITESPAN
BUILDING SYSTEMS INC

CHORD PLASTIFICATION



TRUSSES WITH SQUARE CHORDS OR
TUBING THAT IS TOO THIN IS
SUSCEPTABLE TO CHORD PLASTIFICATION

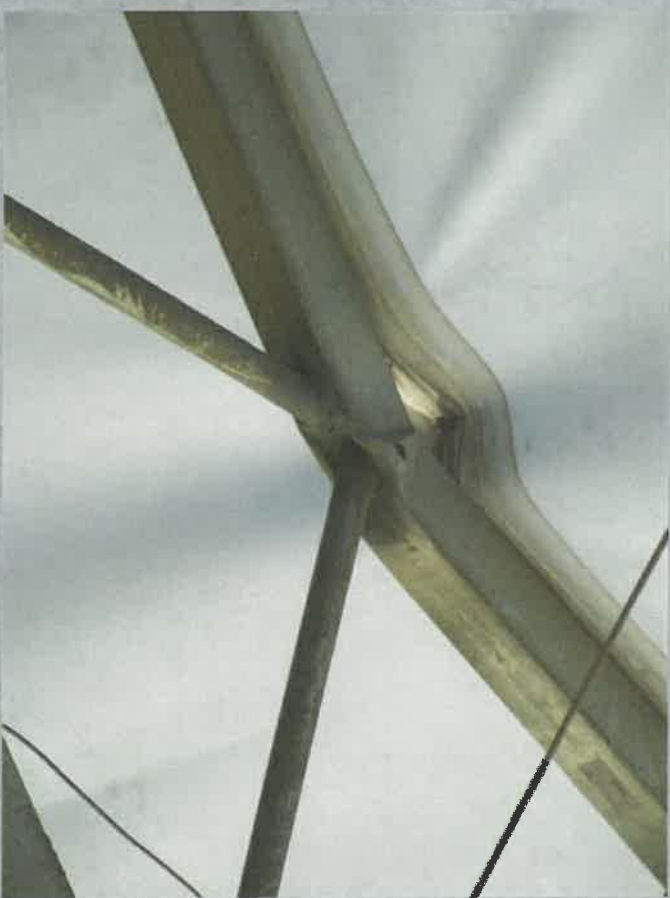

THIS IS WHEN THE WEBBING PUNCHES
THROUGH THE CHORD CAUSING CATASTROPHIC
FAILURE.

PURLIN ATTACHMENT



DOUBLE BOLTED TO AN ENGINEERED
STRUCTURAL MEMBER

Britespan
BUILDING SYSTEMS INC



COMPETITOR'S BUILDING

PURLIN SIZE AND CONSTRUCTION



**1 PIECE CONSTRUCTION FOR MAXIMUM
STRENGTH**



**UNIVERSAL 1 SIZE FITS ALL
CONSTRUCTION 3 TEK SCREWS OF
STRENGTH**

BRITESPAN™
BUILDING SYSTEMS INC.

CABLES



**BOLTED AND PINNED TO AN ENGINEERED
STRUCTURAL TRUSS MEMBER**



**CABLES WRAPPED AROUND SADDLE
BRACKETED PURRLINS**

CABLES



Britespan
BUILDING SYSTEMS INC.



WE USE CABLES THAT TERMINATE AT EVERY BAY WHICH ELIMINATES THE WEAR POINTS OF THE CABLES RUBBING THROUGH THE GALVANIZING ON THE TRUSS

COMPETITORS BUILDING



CONTINUOUS CABLES RUNNING THROUGH TRUSS WEBS WITH NO ATTACHMENT TO ANYTHING ASIDE FROM THE FOUNDATION



Britespan
BUILDING SYSTEMS INC.

WINCH OR RATCHET



BRITESPAN
BUILDING SYSTEMS INC

10,000 lb WINCH BLOCKS FOR
ALL COVER ATTACHMENT

BRITESPAN
BUILDING SYSTEMS INC

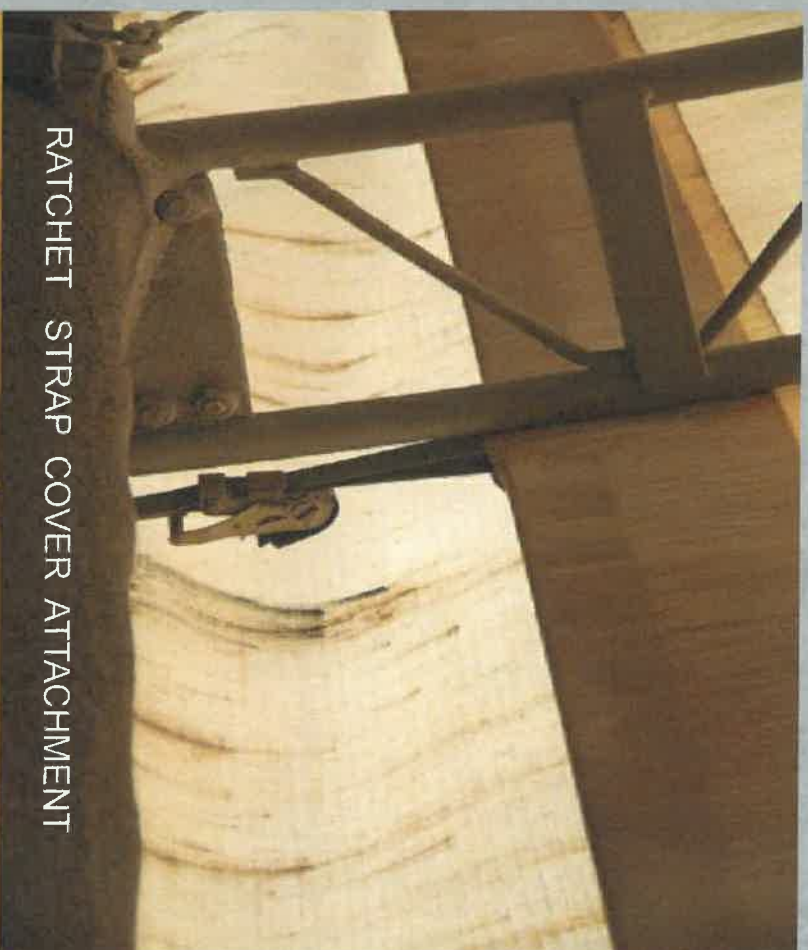

RATCHET STRAP COVER ATTACHMENT



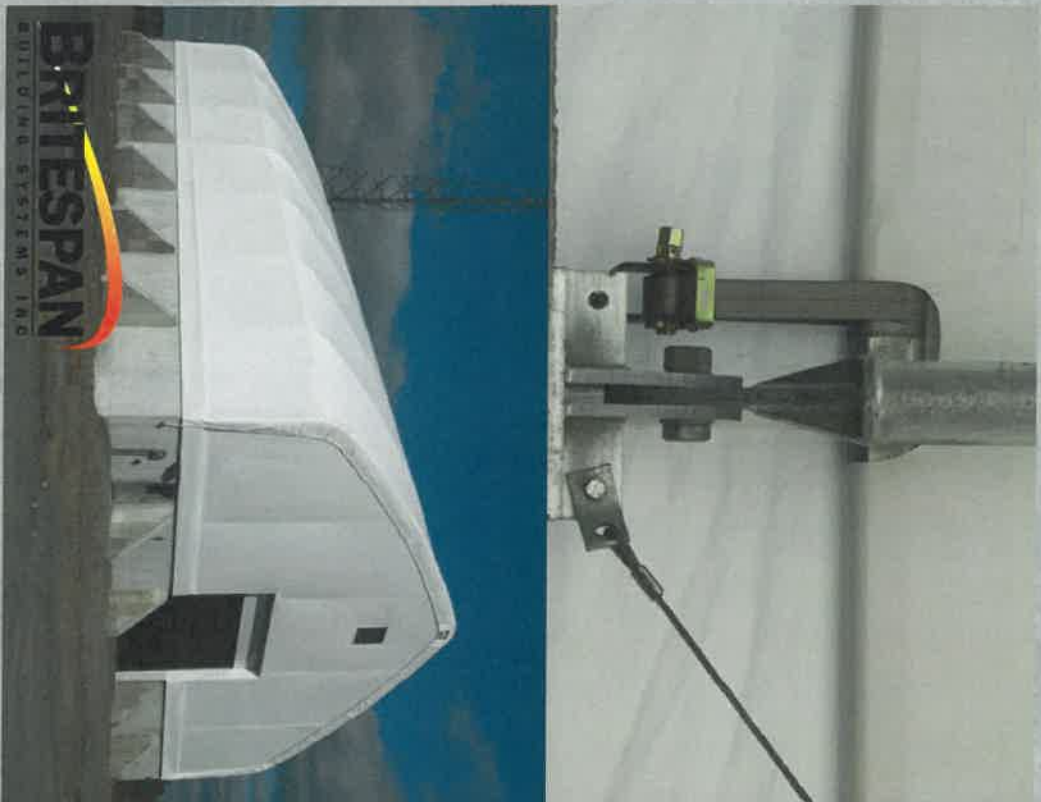

BRITTESPAN USES LARGE AND/OR OVAL
TENSION PIPE TO MAINTAIN PROPER
TENSION OF THE COVER

BRITTESPAN
BUILDING SYSTEMS INC



COMPETITOR'S BUILDING



COMPETITOR'S BUILDING

SOME OF OUR COMPETITION USES 1-1/4"
TENSION PIPE WHICH CAN RESULT IN
PREMATURE FABRIC FAILURE

TENSION PIPE SIZE

TRUSS DEPTH



BRITESPAN'S TRUSSES START AT 18" DEEP



COMPETITOR'S TRUSSES ARE OFTEN 12" DEEP OR LESS AT THE SAME SPAN

BRITESPAN
BUILDING SYSTEMS INC

TRUSS WEIGHT

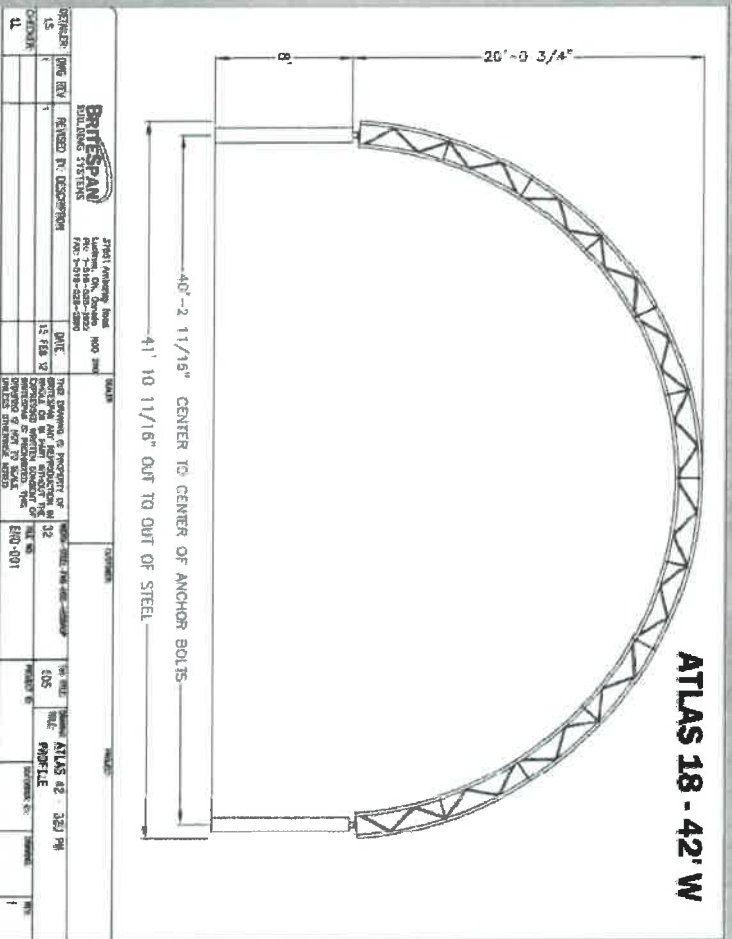

**BRITESPAN'S ATLAS 18-42' TRUSS
WEIGHS 560 POUNDS**

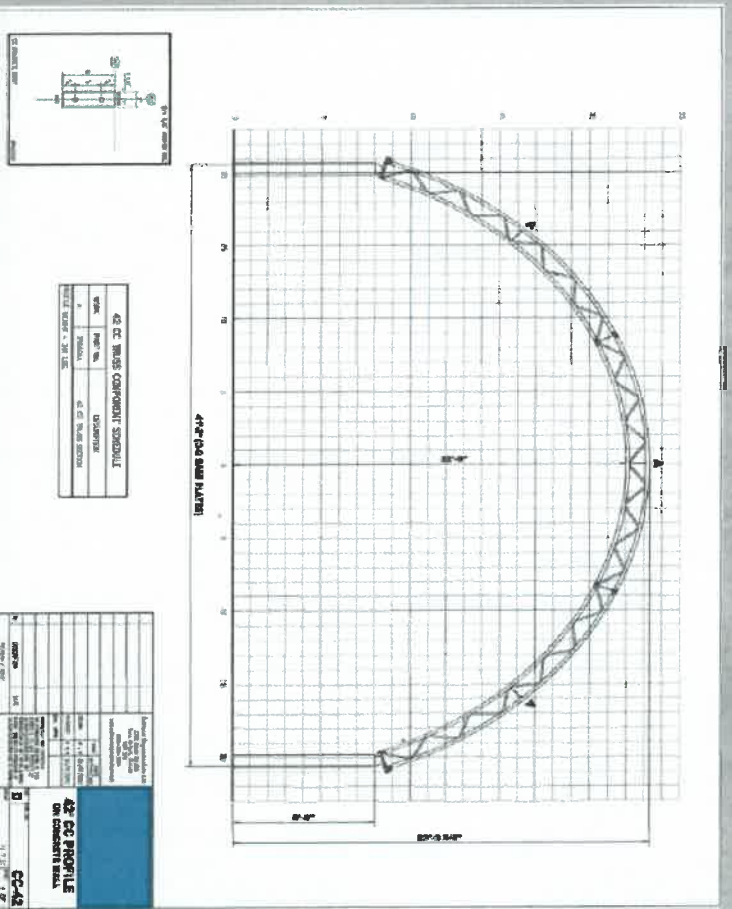

**A COMPETITOR'S 42' TRUSS
WEIGHS 361 POUNDS**



TRUSS CLEARANCE

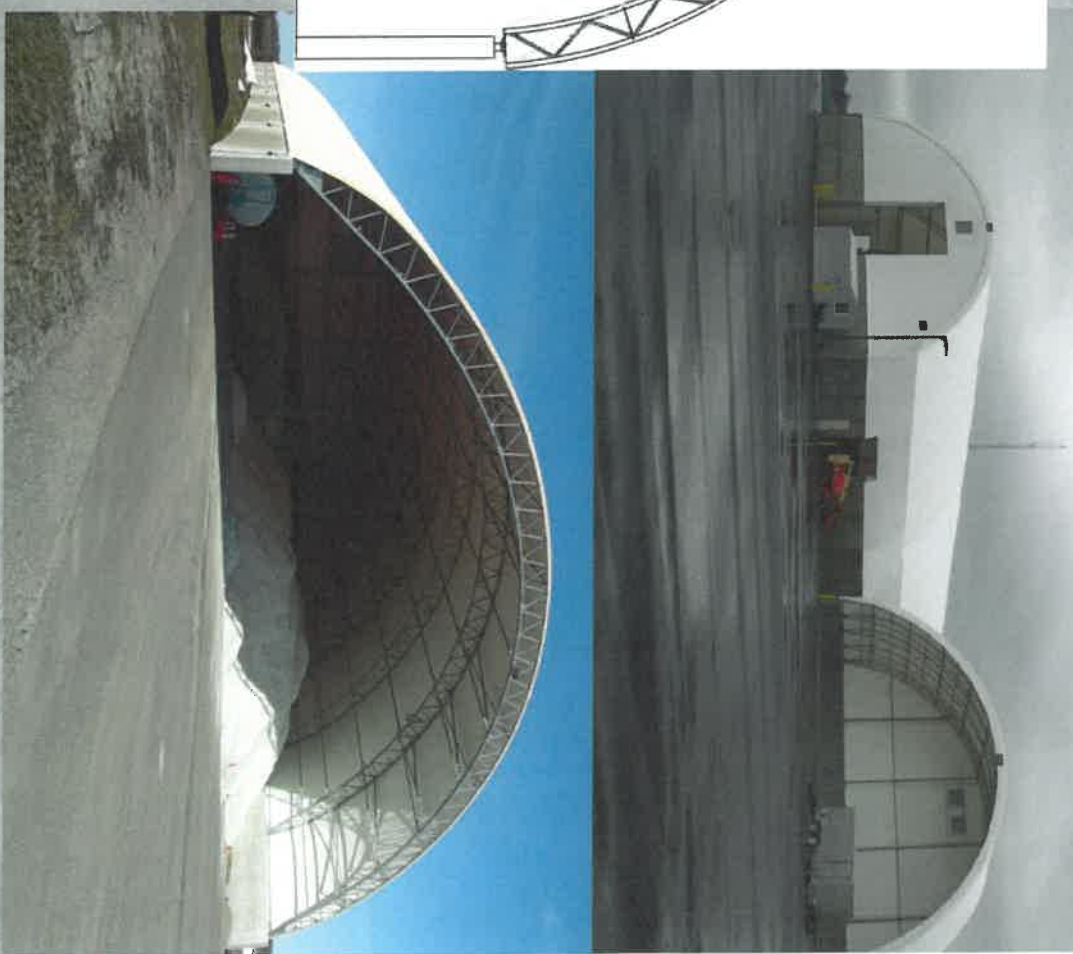
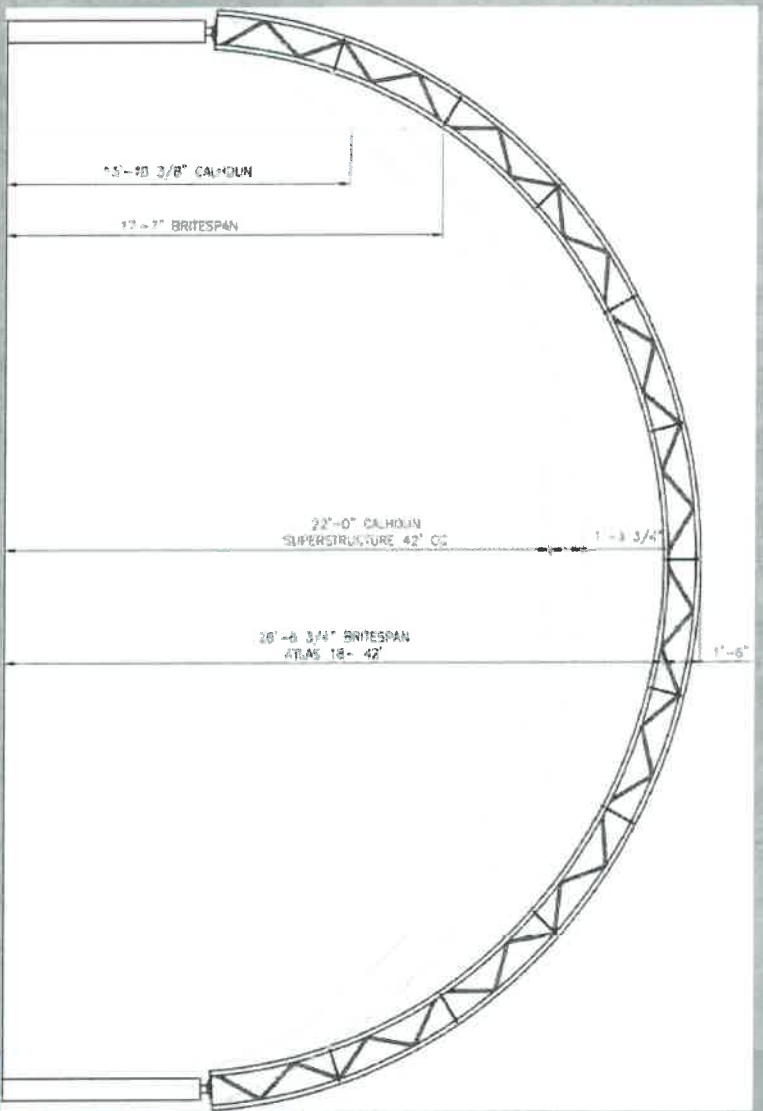

FABRIC CONSTRUCTION



EVERY BRITESPAN COVER IS HEAT WELDED
FOR UNMATCHED DURABILITY



SOME COMPANIES STITCH THEIR COVERS
TOGETHER WHICH PERFORATES THE
FABRIC LEAVING IT SUSEPTABLE TO
TEARING

BRITESPAN
BUILDING SYSTEMS INC

NATURAL LIGHT



**BRITESPAN BUILDING ON AN OVERCAST
DAY WITH LIGHTS TURNED OFF**

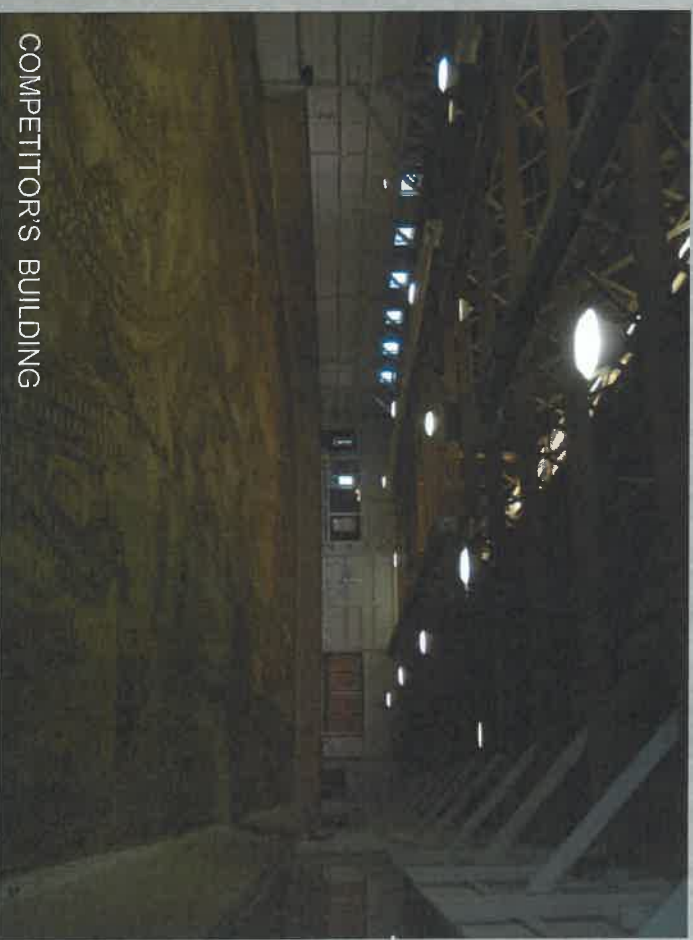

**COMPETITORS BUILDING
POLE BARN WITH SKYLIGHT AND WINDOWS
ON A SUNNY DAY WITH LIGHTS ON**

BRITESPAN
BUILDING SYSTEMS INC

CUSTOMIZATION



EAVES



RIDGE VENTS



CURTAINS





BRITESPAN™
BUILDING SYSTEMS INC.



BRITESPAN
BUILDING SYSTEMS INC



BRITESPAN
BUILDING SYSTEMS INC



BRITESPAN™
BUILDING SYSTEMS INC

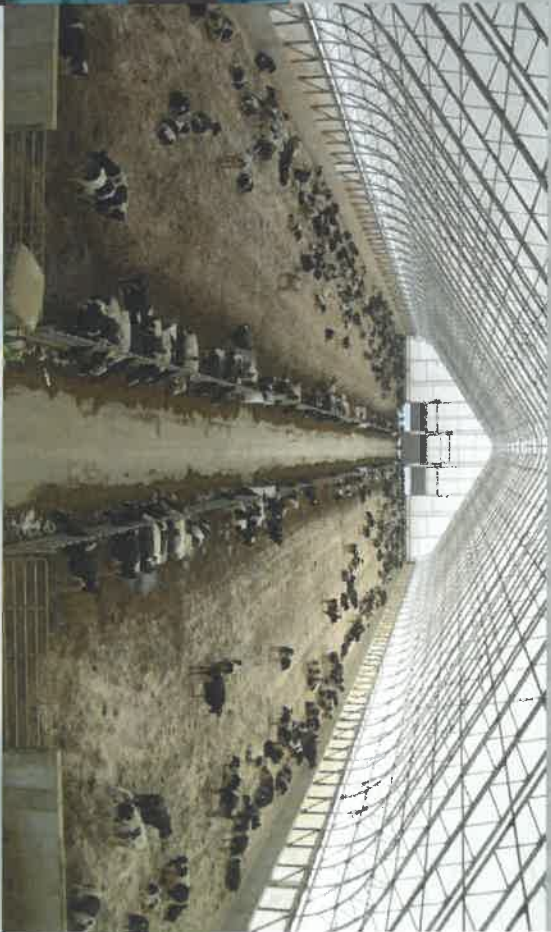



BRITESPAN™
BUILDING SYSTEMS INC.

