



Purchasing Division  
 2019 Washington Street East  
 Post Office Box 50130  
 Charleston, WV 25305-0130

State of West Virginia  
 Request for Quotation  
 13 — Equipment

Proc Folder: 754152

Doc Description: Articulated Boom with Jib for MCA-North (20MCA-548)

Proc Type: Central Purchase Order

Date Issued	Solicitation Closes	Solicitation No	Version
2020-07-15	2020-07-27 13:30:00	CRFQ 0603 ADJ2100000009	1

**BID RECEIVING LOCATION**

BID CLERK  
 DEPARTMENT OF ADMINISTRATION  
 PURCHASING DIVISION  
 2019 WASHINGTON ST E  
 CHARLESTON WV 25305  
 US

RECEIVED  
 2020 JUL 28 PM 1:27

**VENDOR**

Vendor Name, Address and Telephone Number:  
 STATE EQUIPMENT, INC.  
 560 NEW GOFF MOUNTAIN ROAD  
 CROSS LANES, WV 25313  
 (304)776-4405

WV PURCHASING  
 DIVISION

BID RECEIVED LATE  
 Buyer John W Estep  
 Witness Tarable  
 DISQUALIFIED

**FOR INFORMATION CONTACT THE BUYER**

John W Estep  
 (304) 558-7839  
 john.w.estep@wv.gov

Signature [Signature] FEIN # 550658298 DATE 7-24-2020

All offers subject to all terms and conditions contained in this solicitation

**ADDITIONAL INFORMATION:**

Request for Quotation: The West Virginia Purchasing Division is soliciting bids on behalf of West Virginia Adjutant General's Office to establish a contract for the one-time purchase of a Genie Z 45 XC RT Diesel Powered Articulated Boom or equal for Mountaineer Challenge Academy - North. Per the bid requirements, specifications, terms and conditions attached to this solicitation.

INVOICE TO		SHIP TO	
STATE FINANCE ADJUTANT GENERALS OFFICE 1703 COONSKIN DR		MOUNTAINEER CHALLENGE PROGRAM ADJUTANT GENERALS OFFICE 1001 ARMY RD	
CHARLESTON	WV25311-1085	KINGWOOD	WV 26537
US		US	

Line	Comm Ln Desc	Qty	Unit Issue	Unit Price	Total Price
1	Articulated Boom with Jib	1.00000	LS	\$65,951.00	\$65,951.00

Comm Code	Manufacturer	Specification	Model #
22101801	JLG	ARTICULATED BOOM WITH JIB	450AJ

**Extended Description :**

Please see Exhibit "A" pricing page- Genie Z45-ZC Articulated Boom with Job or Equal

**SCHEDULE OF EVENTS**

Line	Event	Event Date
1	Tech Questions due by 10:00am	2020-07-21

<b>ADJ210000009</b>	<b>Document Phase</b> Final	<b>Document Description</b> Articulated Boom with Jib for MCA-North (20MCA-548)	<b>Page 3</b> <b>of 3</b>
---------------------	--------------------------------	---	------------------------------

**ADDITIONAL TERMS AND CONDITIONS**

See attached document(s) for additional Terms and Conditions

Exhibit A Pricing Page

Articulated Boom for MCA North - CRFQ ADJ2100000009

Item	Item Description	Manufacturer for "or equal bids"	Manufacturer's Item Number for "or equal bids"	Quantity	Unit Price	Extended Price
3.1.1	Genie® Z®-45 ZC™ Articulated Boom with Jib	JLG	450AJ	1	\$65,951.00	\$65,951.00 -
					<b>Total Cost</b>	<b>\$65,951.00 -</b>

Bidder / Vendor Information:

Name: STATE EQUIPMENT, INC.  
 Address: 560 NEW GOFF MOUNTAIN ROAD  
 CROSS LANES, WV 25313  
 Phone: (304)776-4405  
 Fax: (304)776-4409  
 E-mail Address: eddie@stateequipment.com



Date: 7-24-2020

STATE OF WEST VIRGINIA  
Purchasing Division

# PURCHASING AFFIDAVIT

**CONSTRUCTION CONTRACTS:** Under W. Va. Code § 5-22-1(i), the contracting public entity shall not award a construction contract to any bidder that is known to be in default on any monetary obligation owed to the state or a political subdivision of the state, including, but not limited to, obligations related to payroll taxes, property taxes, sales and use taxes, fire service fees, or other fines or fees.

**ALL CONTRACTS:** Under W. Va. Code §5A-3-10a, no contract or renewal of any contract may be awarded by the state or any of its political subdivisions to any vendor or prospective vendor when the vendor or prospective vendor or a related party to the vendor or prospective vendor is a debtor and: (1) the debt owed is an amount greater than one thousand dollars in the aggregate; or (2) the debtor is in employer default.

**EXCEPTION:** The prohibition listed above does not apply where a vendor has contested any tax administered pursuant to chapter eleven of the W. Va. Code, workers' compensation premium, permit fee or environmental fee or assessment and the matter has not become final or where the vendor has entered into a payment plan or agreement and the vendor is not in default of any of the provisions of such plan or agreement.

**DEFINITIONS:**

**"Debt"** means any assessment, premium, penalty, fine, tax or other amount of money owed to the state or any of its political subdivisions because of a judgment, fine, permit violation, license assessment, defaulted workers' compensation premium, penalty or other assessment presently delinquent or due and required to be paid to the state or any of its political subdivisions, including any interest or additional penalties accrued thereon.

**"Employer default"** means having an outstanding balance or liability to the old fund or to the uninsured employers' fund or being in policy default, as defined in W. Va. Code § 23-2c-2, failure to maintain mandatory workers' compensation coverage, or failure to fully meet its obligations as a workers' compensation self-insured employer. An employer is not in employer default if it has entered into a repayment agreement with the Insurance Commissioner and remains in compliance with the obligations under the repayment agreement.

**"Related party"** means a party, whether an individual, corporation, partnership, association, limited liability company or any other form or business association or other entity whatsoever, related to any vendor by blood, marriage, ownership or contract through which the party has a relationship of ownership or other interest with the vendor so that the party will actually or by effect receive or control a portion of the benefit, profit or other consideration from performance of a vendor contract with the party receiving an amount that meets or exceeds five percent of the total contract amount.

**AFFIRMATION:** By signing this form, the vendor's authorized signer affirms and acknowledges under penalty of law for false swearing (W. Va. Code §61-5-3) that: (1) for construction contracts, the vendor is not in default on any monetary obligation owed to the state or a political subdivision of the state, and (2) for all other contracts, that neither vendor nor any related party owe a debt as defined above and that neither vendor nor any related party are in employer default as defined above, unless the debt or employer default is permitted under the exception above.

**WITNESS THE FOLLOWING SIGNATURE:**

Vendor's Name: STATE EQUIPMENT, INC.

Authorized Signature: [Signature] Date: 7-24-2020

State of WEST VIRGINIA

County of KANAWHA, to-wit:

Taken, subscribed, and sworn to before me this 24<sup>th</sup> day of July, 2020

My Commission expires March 27, 2021.

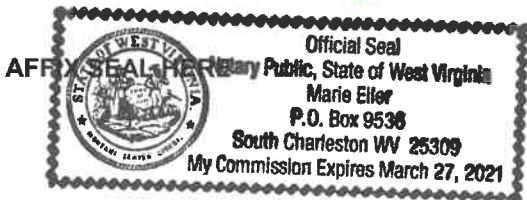

NOTARY PUBLIC [Signature]

**DESIGNATED CONTACT:** Vendor appoints the individual identified in this Section as the Contract Administrator and the initial point of contact for matters relating to this Contract.

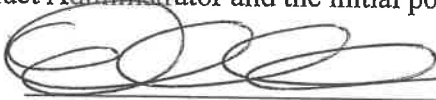
  
\_\_\_\_\_  
(Name, Title) GENERAL MANAGER  
EDDIE ROWAN, JR. GENERAL MANAGER  
(Printed Name and Title)  
\_\_\_\_\_  
560 NEW GOFF MOUNTAIN ROAD CROSS LANES, WV 25313  
(Address)  
\_\_\_\_\_  
(304) 776-4405 (304) 776-4409  
(Phone Number) / (Fax Number)  
\_\_\_\_\_  
eddie@stateequipment.com  
(email address)

**CERTIFICATION AND SIGNATURE:** By signing below, or submitting documentation through wvOASIS, I certify that I have reviewed this Solicitation in its entirety; that I understand the requirements, terms and conditions, and other information contained herein; that this bid, offer or proposal constitutes an offer to the State that cannot be unilaterally withdrawn; that the product or service proposed meets the mandatory requirements contained in the Solicitation for that product or service, unless otherwise stated herein; that the Vendor accepts the terms and conditions contained in the Solicitation, unless otherwise stated herein; that I am submitting this bid, offer or proposal for review and consideration; that I am authorized by the vendor to execute and submit this bid, offer, or proposal, or any documents related thereto on vendor's behalf; that I am authorized to bind the vendor in a contractual relationship; and that to the best of my knowledge, the vendor has properly registered with any State agency that may require registration.

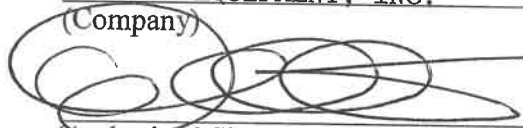
STATE EQUIPMENT, INC.  
(Company)  
  
\_\_\_\_\_  
(Authorized Signature) (Representative Name, Title) GENERAL MANAGER  
EDDIE ROWAN, JR. GENERAL MANAGER  
(Printed Name and Title of Authorized Representative)  
\_\_\_\_\_  
7-24-2020  
(Date)  
\_\_\_\_\_  
(304) 776-4405 (304) 776-4409  
(Phone Number) (Fax Number)

# JLG® ENGINE POWERED

Mobile Elevating Work Platforms



**JLG**®

## JLG® MOBILE ELEVATING WORK PLATFORMS

On the job site, days are measured by productivity. Your productivity. Which means you need equipment that stands up to the day's demands. JLG has what you need so you can put in the most productive day possible. Engine powered boom lifts that take you higher and farther. Scissor lifts that can handle more workers and supplies in one shot.

Whether you're treading on slab or off, JLG boom and scissor lifts provide superior performance and reliability. Our boom lifts feature larger work envelopes, enhanced capacities and reach heights that will let you rise to the challenge. Our engine powered scissor lifts deliver exceptional terrainability and gradeability. Carry all the workers, materials and tools you need, including our WorkStation in the Sky® accessories, to tackle difficult tasks at height.

Give your day's productivity a major boost with JLG engine powered mobile elevating work platforms.

*"JLG" machines give me all the power I need to get the job done on time and on budget."*





### NARROW DESIGN. EASY MOBILITY.

With standard four-wheel drive, rugged lug tread tires and 35% gradeability, you'll be able to keep work moving, on or off slab. The 260MRT midsize rough terrain scissor lift delivers exceptional mobility thanks to a narrow 69 in. (1.75 m) chassis that gets you into those challenging spots. A large work platform with a 4 ft (1.2 m) roll-out deck extension keeps everything you need within arm's reach. Simplified ground control wiring and built-in diagnostics are provided for serviceability.

*"Getting around crowded job sites is no problem."*

### HIGHER CAPACITIES. BIGGER PLATFORMS.

The powerful LRT Series lets you work more efficiently on the job, over a range of applications, with increased lift capacities and bigger platforms. This is critical when you have applications requiring multiple sheets of drywall or siding. When you want to finish on time and on budget, put the LRT Series to work for you.

Set up quickly and efficiently with the optional one-touch leveling jacks. With an average leveling time of 15 to 30 seconds, you can cut setup time by 100% compared to other scissor lifts.



**TRAVERSE ROUGH TERRAIN**  
Hydrostatic four-wheel drive delivers unmatched terrainability and up to 45% gradeability.



## 260MRT SERIES



### Room to Work

Larger deck space and 1,250 lb capacity so you can be more productive.



### Serviceability

Ease of service with built-in diagnostics.



## LRT SERIES

### Leveling Jacks

Meet uneven surfaces head-on with the push of a button. You get precise leveling when positioned on up to a five-degree angle from side to side and up to a four-degree angle from front to rear.



### More Capacity

Maximum 2,150 lb capacity for more workers and materials.

### TACKLE ANY JOB SITE CHALLENGE

With features that reduce your total cost of ownership, the 340AJ articulating boom provides industry-leading terrainability and an environmentally friendly Tier 4 diesel engine. Its versatility makes it ideal for general contractors, steel erectors, painters, stadium construction and more.

### IMPROVED ACCESS

A standard articulating jib and over 19 ft (5.79 m) of outreach on the 340AJ and 25 ft (7.62 m) of outreach on the 450AJ let you access hard-to-reach places.



### GO FARTHER WITH A WIDER RANGE OF MOTION

When you're working around tricky architecture or smaller spaces where access can be limited, the 450AJ helps you stay on track. With a larger work envelope, you can extend your reach and increase your productivity. The exclusive Control ADE® (Advanced Design Electronics) system improves your performance and serviceability. Our familiar control system, used on other JLG® engine powered boom lifts, means less time training and more time working.

### SKYGUARD® TECHNOLOGY COMES STANDARD

Boom lift operators experience enhanced control panel protection with SkyGuard. When activated by approximately 50 lb (23 kg) of force, SkyGuard technology stops all functions in use at the time, then momentarily reverses most functions that were in use.



### 340AJ



**Durability Built In**  
Steel needs no extra added durability on the most rugged job sites.



**45% Gradeability**  
Improved rough terrain capability has not equalled off-stab productivity.

### 450AJ



**More Capacity**  
Bring more loads to the job with a larger 350-lb platform capacity.



**Stay on the Job Longer**  
Provides better fuel efficiency to lower costs and increase uptime.

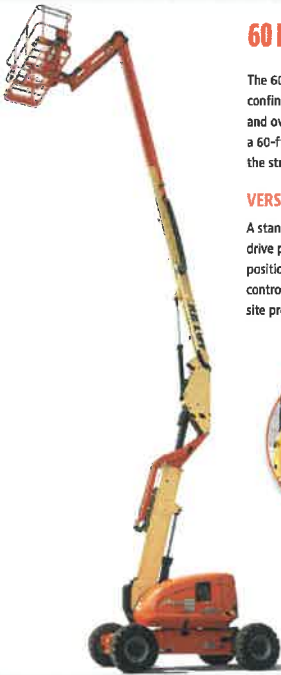

### 60 FT OF POWERFUL PERFORMANCE

The 600 Series articulating booms feature a narrow chassis option for access to confined areas and the industry's best work envelope—26 ft 7 in. (8.1 m) of up and over height and up to 39 ft 9 in. (12.12 m) of horizontal outreach. And with a 60-ft (18.29-m) platform height and a capacity of 500 lb (227 kg), you get all the strength and reach capacity you need, no matter what the job.

#### VERSATILE PERFORMER

A standard oscillating axle and optional four-wheel drive give you outstanding drive performance on rough terrain. Optional four-wheel steer with three-position switch provides unmatched agility in tight spaces. Improved platform controls have been redesigned for smoother, controlled operation and job site productivity.



**WORK IN CROWDED AREAS**  
Optional 7 ft (2.13 m) wide chassis fits in narrow spaces.



### GREATER PRODUCTIVITY—FROM THE GROUND UP

You can reach higher and get to your work faster with the 800 Series. Our exclusive QuikStik™ boom takes you from the ground to 80 ft (24.38 m) in less than 50 seconds. Whether you're venturing on or off rough terrain, the 800 Series has all the strength and versatility you need.

#### EXTRA REACH AND IMPROVED PERFORMANCE

With the industry's best reach envelope—32 ft (9.75 m) of up and over and 51 ft (15.54 m) of outreach, there's no obstacle you can't handle. Be the boss of rough terrain thanks to improved traction from the oscillating axle and 45% gradeability.



#### BETTER MACHINE PERFORMANCE

Advanced Design Electronics (Control AD2™) System provides smoother machine functions, improved fuel efficiency and reduced emissions.

## 600 SERIES



#### Better Access

110-degree models add 70 degrees of upswing and 40 degrees of downward motion.



#### Go Anywhere

Foot-wheel drive option and a standard oscillating axle provide superior terrainability.

## 800 SERIES



#### Added Versatility

Exclusive Work Station in the Sky™ options and accessories help extend the versatility of your machine.



#### Easier to Maintain

Swing-out engine tray allows for faster and easier access for routine maintenance.

## THE FASTEST LIFT AND DRIVE SPEEDS IN THEIR CLASS

Experience a productivity boost with the 400 Series. With a lift speed of 33 seconds, 4.25 mph (6.8 kph) drive speed and up to 3.5 ft (1.07 m) more reach, you can get to work quickly and efficiently. Customize your function speeds with the Control ADE® system.

### STAY IN CONTROL

Customer-preferred controls mean fewer buttons and switches used to position the platform and less time spent learning to use the platform controls. Our exclusive Control ADE® system improves machine maintainability while an engine swing-out tray provides greater serviceability access. For jobs that require welding, choose a model with an on-board Miller® welding system (see page 13).



## CONQUER HIGHER CHALLENGES AND TOUGHER TERRAIN

With the powerful combination of performance and reliability of the 600 Series, you can conquer all of your worksite challenges. The JLG® 600 Series has the industry's highest platform capacity of up to 1,000 lb (454 kg) and the largest work envelope for improved access. Mud, sand and rough terrain are no match for the standard oscillating axle and 45% gradeability. Additional features include a versatile articulating jib for a wider range of motion, a swing-out engine tray for easier access for routine maintenance and smoother machine functions.

### CRAWL ALL OVER TOUGH JOBS

When you need ultimate terrainability, choose the 600 Crawler Series. A crawler undercarriage, up to 750-lb (340-kg) capacity, improved maneuverability on soft surfaces and zero turning radius get you in places others just can't go. Plus, the 600 Crawler Series is equipped with all-steel tracks.



## 400 SERIES



**More Reach**  
A 6 ft articulating jib gives you the added access you need.



**Greater Capacity**  
20% lifting platform capacity than competitive models (1,000 lb unrestricted).

## 600 SERIES



**More Outreach**  
Up to 57 ft of horizontal outreach for improved access.



**45% Gradeability**  
A 45% oscillating axle improves traction over mud and uneven terrain.



## HIGHER REACH. CONFIDENT CONTROL.

Go from the ground to 80 ft in less than 67 seconds—that's 40% faster than the competition. These 80 ft machines are packed with job-proven performance—up to 75 ft (22.86 m) of horizontal outreach and dual-rated platform capacities up to 1,000 lb (454 kg). Its narrow fixed-width chassis gets you in and out of confined spaces while the 6 ft (1.83 m) articulating jib gives you the additional access you need.

### ADVANCED CONTROLS

With the same set of controls installed on the entire JLG® boom lift family, you'll find that operating your lift is simple. The Advanced Design Electronics (Control ADE®) system provides smoother machine functions, increased fuel efficiency and reduced emissions.

### WORKSTATION IN THE SKY® ACCESSORIES

Choose packages built for welding, cutting steel, using power tools or working at night.



## CONTROL ADE® SYSTEM

Our exclusive Advanced Design Electronics (Control ADE®) System helps optimize productivity while lowering your owning and operating costs.

- **Commonality of Components—**  
The Control ADE® System is standard across all JLG® engine-powered boom models.
- **Higher Productivity—**  
Provides smoother machine functions, increased fuel efficiency and reduced emissions.
- **Enhanced Reliability—**  
Significantly reduces the number of wires and connections.
- **Improved Serviceability—**  
The self-test capability reduces troubleshooting time and identifies potential problems.
- **Enhanced Performance—**  
Allows function speeds and options to be customized to meet customer preferences.

## 800 SERIES



**Narrow Width**  
Narrow fixed-width frame allows for faster setup.



**Solid Ground**  
45% gradeability and oscillating axle for improved traction.

## FEATURES



**Lift/Swing**  
Multiple use of control—lift and swing can be operated simultaneously.



**Drive Control**  
Ease of drive operation—joystick with integrated thumb steer.



**Ground Control Console**  
Mounted in the turbine, the ground control console features function symbols to guide you.

## WORKSTATION IN THE SKY® ACCESSORIES

Turn your engine powered mobile elevating work platform into an integrated work tool with WorkStation in the Sky accessories. These packages are designed to increase your productivity, conserve platform space and improve working conditions. Additional accessories are available through JLG® Aftermarket.

### SKYPOWER® PACKAGE

Machines with the SkyPower system are equipped with a self-contained 7,500W continuous output generator with a power cable installed in the power track. In addition, it provides self-contained 110V-AC, 220V-AC and 3-phase power to run other accessories and hand tools.

### SKYWELDER® PACKAGE

With a 280-amp Miller® CST™ 280 welder tucked into the SkyPower™ platform, space is conserved while providing stick and TIG capability. The SkyWelder package eliminates potentially dangerous leads hanging over the rails and the unnecessary cost of a stand-alone welder and power supply.

### SKYSENSE™

SkySense is an enhanced detection system that uses strategically placed object detection sensors to provide operators with an added level of awareness of their immediate surroundings as they operate the machine.

### MILLER® ON BOARD

Miller welders and plasma cutters are mounted in the platform to increase workspace and for added productivity.

### SKYCUTTER® PACKAGE

Eliminating the danger of tanks and draping hoses, SkyCutter cuts faster and cleaner with an on-board Miller® Spectrum 375 Cutmate plasma cutter.

### SKYAIR® PACKAGE

With an integrated on-board air compressor, the SkyAir package delivers 9.3 CFM at pressures up to 125 psi. It increases productivity by eliminating the need for a ground-based compressor.

Note: Some options and accessories available exclusively through JLG Parts, Service and Support.





**PIPE RACKS**

Conserve platform space and reduce trip hazards by storing the materials outside of the platform. Pipe racks help keep your tools and materials organized and within reach. Pipe racks come standard with plumbing, plant maintenance and electrician packages.



**WORKSTATION IN THE SKY™**

The removable WorkStation in the Sky helps you to optimize platform space with compartments for tools such as reciprocating saws, drills or circular saws. The WorkStation has 6 x 6 in. compartments for keeping boxes of connectors, hangers or other fasteners within easy reach and off the floor. It also features a pull-out tray that provides a flat working surface near the top of the platform rails.



An optional 12V plug is connected to the scissor batteries to provide power to the customer-supplied tool or phone charger.

The WorkStation is a standard feature on plumbing, plant maintenance and electrician packages.

**JLG™ MOBILE CONTROL**

Mobile Control is an advanced option from JLG that allows you to drive, steer and load your scissor lift from your mobile device.



Note: Some options and accessories available exclusively through JLG Parts, Service and Support.



**PUTTING YOUR WORK ABOVE EVERYTHING**



When it comes to JLG® Support, it's all about you. Your productivity. Your profitability. Your uptime. From the purchase of your first piece of equipment straight through to the training, parts and maintenance that follow.

- **Customer Support Contact Center**  
You can be assured we'll be giving an all-out effort to support you. Just think of us as your personal on-call, full-service support team. We make it happen. Period.
- **Financial Solutions**  
Maximizing your profits. Preserving your cash flow. Let our financing specialists help choose the program designed specifically for your needs.
- **Aftermarket Parts**  
Keep your equipment running at peak performance with genuine replacement parts, accessories, attachments, rebuilt and competitive parts all from one source — JLG.
- **Training**  
Knowing your equipment inside and out results in higher productivity on the job. Our instructor-led courses give you the hands-on time you need to successfully operate equipment.
- **Service Centers**  
Your needs. Your uptime. JLG is on the job to fulfill your every need, from repair, reconditioning, same-day parts and much more. We're here to support you.
- **Pre-Owned Equipment**  
As a high-value alternative to purchasing new equipment, you can search our used equipment inventory of pre-owned JLG® and competitor products.



- Main Features**
- Oscillating axle on 330LRT and 430LRT
  - 4-wheel drive
  - Automatic transmission
  - 4-ft (1.22 m) manual deck extension
  - 110V-AC receptacle in platform

260MRT	
<b>Midsized Rough Terrain Scissor Lifts</b>	
Platform Height	26 ft (7.92 m)
Platform Capacity	1,250 lb (567 kg)
Capacity on Extension	300 lb (136 kg)
No. Occupants (Indoor/outdoor)	2/2
Platform Size	65 x 102 in. (1.65 x 2.59 m)
Overall Width	5 ft 9 in. (1.75 m)
Weight <sup>1</sup>	7,360 lb (3,338 kg)
Tilt Rating	3°
Dual Fuel Engine—Kubota	24.5 hp (18.3 kW)
Diesel Engine—Kubota	23.5 hp (17.5 kW)

	330LRT	430LRT	530LRT
<b>LRT Series Rough Terrain Scissor Lifts</b>			
Platform Height	33 ft (10.06 m)	43 ft (13.1 m)	53 ft (16.2 m)
Platform Capacity	2,250 lb (1,020 kg)	1,500 lb (680 kg)	1,500 lb (680 kg)
Capacity on Extension	500 lb (227 kg)	500 lb (227 kg)	500 lb (227 kg)
Capacity w/ Dual Extensions	2,000 lb (907 kg)	1,250 lb (567 kg)	1,500 lb (680 kg)
No. Occupants	6	6	6
Platform Size	75 x 154 in. (1.95 x 3.92 m)	79 x 154 in. (1.95 x 3.92 m)	73.5 x 155 in. (1.87 x 3.96 m)
Overall Width	7 ft 9 in. (2.36 m)	7 ft 9 in. (2.36 m)	7 ft 7 in. (2.31 m)
Weight <sup>1</sup>	11,870 lb (5,372 kg)	8,510 lb (3,864 kg)	12,000 lb (5,443 kg)
Tilt Rating	3°	3°	1.5°
Dual Fuel Engine—Kubota WG672 (water cooled)	31 hp (23.2 kW)	31 hp (23.2 kW)	31 hp (23.2 kW)
Diesel Engine—Kubota D1305 Tier 4 Final (water cooled)	24 hp (18.5 kW)	24 hp (17.9 kW)	24 hp (17.9 kW)

**Available Options**

3,000 Watt, 110V-AC Power Pack Generator	-	-	-
3,500 Watt, 110V-AC Generator	-	-	-
33.5 lb (15.19 kg) Propane Tank	-	-	-
43.5 lb (19.73 kg) Propane Tank	-	-	-
Flashing Amber Beacon	-	-	-
Leveling Jacks	-	-	STD
Platform Worklights	-	-	-
Self-Closing Entry Gate	-	-	STD
1/2 In. Air Line to Platform	-	-	-
Dual 48 in. Manual Deck Extensions	-	-	-
Cold Weather Start Kit (CW)—Includes battery heater, hydraulic tank heater and block heater.	-	-	-
7,500 Watt Generator	-	-	-
4,000 Watt Generator	-	-	-

<sup>1</sup> Certain options or country standards may increase weight

	340AJ	450A	450AJ
<b>450 Series II and Model 340AJ Articulating Boom Lifts</b>			
Platform Height	33 ft 10 in. (10.33 m)	45 ft (13.72 m)	45 ft (13.72 m)
Platform Capacity—Unrestricted	500 lb (227 kg)	550 lb (250 kg)	550 lb (250 kg)
Horizontal Outreach	39 ft 11 in. (12.08 m)	30 ft (9.14 m)	25 ft (7.62 m)
Up and Over Height	17 ft (5.17 m)	24 ft (7.3 m)	24 ft (7.3 m)
Overall Width	6 ft 4 in. (1.93 m)	7 ft 8 in. (2.35 m)	7 ft 8.6 in. (2.35 m)
Weight <sup>1</sup>	9,700 lb (4,400 kg)	15,850 lb (7,190 kg)	14,500 lb (6,578 kg)
Dual Fuel Engine—Kubota D1105	24.8 hp (18.5 kW)	—	—
Kubota D1F WG2503	—	61 hp (45.5 kW)	61 hp (45.5 kW)
Diesel Engine—Kubota D1105	24.8 hp (18.5 kW)	—	—
Deutz TD2.9L4 Tier 4 Final	—	49 hp (36.5 kW)	49 hp (36.5 kW)

**Available Options**

1/2 In. Air Line to Platform	-	-	-
SkyPower™	-	-	-
Cold Weather Start Kit—Includes battery heater, hydraulic tank heater and block heater.	-	-	-
Arctic Package (diesel only)	-	-	-
Self-Closing Gate	-	-	-
SkySense™	-	-	-

<sup>1</sup> Certain options or country standards may increase weight

<sup>2</sup> Includes anti-siphon hoses (drive and steer only) and main boom cable, engine cold engine oil, fuel conditioner, engine block heater, battery heater, glow plugs, hydraulic tank heater, overused footswitch and arc hydraulic oil

	600AJ	600AJ Narrow
<b>600 Series Articulating Boom Lifts</b>		
Platform Height	60 ft 7 in. (18.46 m)	60 ft 7 in. (18.46 m)
Platform Capacity—Restricted	N/A	N/A
Platform Capacity—Unrestricted	500 lb (227 kg)	500 lb (227 kg)
Horizontal Outreach	39 ft 9 in. (11.81 m)	35 ft 9 in. (11.81 m)
Up and Over Height	26 ft 7 in. (8.1 m)	26 ft 7 in. (8.1 m)
Overall Width	8 ft 2 in. (2.49 m)	7 ft (2.13 m)
Weight <sup>1</sup>	22,691 lb (10,292 kg)	24,200 lb (10,977 kg)
Dual Fuel Engine—Ford MSG425-DP	84 hp (62.6 kW)	84 hp (62.6 kW)
Diesel Engine—Deutz TD2.9L4 Tier 4 Final	49 hp (36.4 kW)	49 hp (36.4 kW)

**Available Options**

1/2 In. Air Line to Platform	-	-
SkyPower™	-	-
43.5 lb (19.73 kg) Propane Tank	-	-
Cold Weather Start Kit—Includes engine block heater, battery heater and oil tank heater.	-	-
Arctic Package <sup>2</sup>	-	-
Self-Closing Gate	-	-
SkySense™	-	-

<sup>1</sup> Certain options or country standards may increase weight

<sup>2</sup> Includes anti-siphon hoses (drive and steer only) and main boom cable, engine cold engine oil, fuel conditioner, engine block heater, battery heater, glow plugs, hydraulic tank heater, overused footswitch and arc hydraulic oil

For complete specifications, visit [www.jlg.com](http://www.jlg.com)



- Main Features**
- Oscillating axle
  - 2-wheel drive or 4-wheel drive (450A/450AJ)
  - Control ADE System in platform
  - Easy access swing-out engine tray



- Main Features**
- Choice of chassis width available
  - 2-wheel drive or 4-wheel drive
  - Oscillating axle
  - Control ADE System
  - 110V-AC receptacle in platform
  - Easy access swing-out engine tray





**Main Features**

- Industry's best reach envelope in its class
- Exclusive OutStik™ boom
- Oscillating axle and 4-wheel drive
- SkyPower™ 7500W Generator

	800A	800AJ
<b>800 Series Articulating Boom Lifts</b>		
Platform Height	80 ft (24.38 m)	80 ft (24.38 m)
Platform Capacity—Restricted	1,000 lb (454 kg)	N/A
Platform Capacity—Unrestricted	500 lb (227 kg)	500 lb (227 kg)
Horizontal Outreach	53 ft (16.15 m)	51 ft 10 in. (15.8 m)
Up and Over Height	32 ft 1 in. (9.78 m)	32 ft 1 in. (9.78 m)
Overall Width	8 ft 2 in. (2.49 m)	8 ft 2 in. (2.49 m)
Weight <sup>1</sup>	34,300 lb (15,558 kg)	34,738 lb (15,757 kg)
Dual Fuel Engine—Ford MS6425-DF	84 hp (62.2 kW)	84 hp (62.2 kW)
Diesel Engine—Deutz TD2.9L4 Tier 4 Final	67 hp (50 kW)	67 hp (50 kW)
<b>Available Options</b>		
15-625 Foam-Filled Tires <sup>2</sup>	-	-
36 x 72 in. (0.91 x 1.83 m) Platform	-	-
43.5 lb (19.73 kg) Propane Tank	-	-
Cold Weather Start Kit <sup>3</sup> —Includes engine block heater, battery heater and oil tank heater.	-	-
Arctic Package <sup>2</sup>	-	-
Hostile Environment Kit <sup>3</sup> —Includes console cover, boom wipers and cylinder bellows.	-	-
Self-Closing Gate	-	-
SkySense™	-	-

<sup>1</sup> Certain options or country standards may increase weight  
<sup>2</sup> Foam-filled tires may not be repaired with pneumatic  
<sup>3</sup> Includes arctic hydraulic hoses (line and steer only) and main boom cable, extreme cold engine oil, fuel conditioner, engine block heater, battery blanket, glow plugs, hydraulic tank heater, oversized footswitch and arctic hydraulic oil

	400S	460SJ	400SC	460SJC
<b>400 Series Telescopic Boom Lifts</b>				
Platform Height	40 ft (12.19 m)	46 ft (14.05 m)	36 ft 6.5 in. (11.05 m)	45 ft 5.4 in. (13.88 m)
Platform Capacity—Restricted	1,000 lb (454 kg)	N/A	1,000 lb (454 kg)	N/A
Platform Capacity—Unrestricted	600 lb (272 kg)	600 lb (272 kg)	600 lb (272 kg)	500 lb (227 kg)
Horizontal Outreach	33 ft 1.5 in. (10.23 m)	33 ft (10 m)	33 ft (10 m)	39 ft (12 m)
Overall Width	7 ft 6.8 in. (2.31 m)	7 ft 6.8 in. (2.31 m)	7 ft 4 in. (2.23 m)	7 ft 4 in. (2.23 m)
Weight <sup>1</sup>	14,520 lb (6,586 kg)	16,600 lb (7,530 kg)	14,559 lb (6,603 kg)	13,996 lb (6,344 kg)
Dual Fuel Engine—Kubota WG2503-DF	61 hp (45.5 kW)	61 hp (45.5 kW)	-	-
Diesel Engine—Deutz DZ.9L4 Tier 4 Final	49 hp (36.5 kW)	49 hp (36.5 kW)	49 hp (36.5 kW)	49 hp (36.5 kW)
<b>Available Options</b>				
1/2 in. Air Line to Platform	-	-	-	-
SkyPower™ 7500W Generator	-	-	-	-
36 x 72 in. (0.91 x 1.83 m) Platform	-	-	-	-
43.5 lb (19.73 kg) Propane Tank	-	-	-	-
Cold Weather Start Kit <sup>3</sup> —Includes engine block heater, battery heater and oil tank heater.	-	-	-	-
Arctic Package <sup>2</sup>	-	-	-	-
Self-Closing Gate	-	-	-	-
SkySense™	-	-	-	-

<sup>1</sup> Certain options or country standards may increase weight  
<sup>2</sup> Includes arctic hydraulic hoses (line and steer only) and main boom cable, extreme cold engine oil, fuel conditioner, engine block heater, battery blanket, glow plugs, hydraulic tank heater, oversized footswitch and arctic hydraulic oil

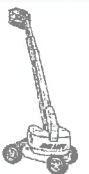

**Main Features**

- 90% faster boom speed
- 100% more platform capacity
- 25% faster drive speeds
- Oscillating axle



- Main Features**
- Oscillating axle
  - Control ADE® System
  - TUV-AC receptacle in platform

	600S	660SJ	660SJC
<b>600 Series Telescopic Boom Lifts</b>			
Platform Height	59 ft 8 in. (18.18 m)	65 ft 8 in. (20.02 m)	65 ft 7 in. (19.99 m)
Platform Capacity—Restricted	1,000 lb (454 kg)	750 lb (340 kg)	750 lb (340 kg)
Platform Capacity—Unrestricted	600 lb (272 kg)	550 lb (250 kg)	550 lb (250 kg)
Horizontal Outreach	50 ft 2 in. (15.29 m)	57 ft 1 in. (17.40 m)	57 ft 0.6in. (17.38 m)
Overall Width	8 ft 2 in. (2.49 m)	8 ft 2 in. (2.49 m)	8 ft 2 in. (2.49 m)
Weight <sup>1</sup>	22,900 lb (10,387 kg)	25,341 lb (11,494 kg)	22,620 lb (10,258 kg)
Dual Fuel Engine—Ford MS6425-DF	84 hp (62.6 kW)	84 hp (62.6 kW)	—
Diesel Engine—Deutz T2.9L4 Tier 4	48.8 hp (36.4 kW)	48.8 hp (36.4 kW)	—
Diesel Engine—Deutz TD2.9L4 Tier 4 Final	—	—	57 hp (50 kW)
<b>Available Options</b>			
Light Package—Includes head and tail lights, platform worklights and beacon.	—	—	—
36 x 72 in. (0.91 x 1.83 m) Platform	—	—	—
43.5 lb (19.73 kg) Propane Tank	—	—	—
Cold Weather Start Kit—Includes engine block heater, battery heater and oil tank heater.	—	—	—
Arctic Package <sup>2</sup>	—	—	—
Flashing Amber Beacon	—	—	—
Hostile Environment Kit—Includes boom wipers, cylinder bellows and console cover.	—	—	—
Self-Closing Gate	—	—	—
SkySense™	—	—	—

<sup>1</sup> Certain options or country standards may increase weight.  
<sup>2</sup> Includes Arctic Hydraulic hoses (30-wire min only) and main boom cable, extreme cold engine oil, fuel conditioner, engine block heater, battery blanket, glow plugs, hydraulic tank heater, overwind footswitch and Arctic hydraulic oil.



- Main Features**
- Substantial horizontal reach
  - Control ADE® System
  - TUV-AC receptacle in platform

	800S	860SJ
<b>800 Series Telescopic Boom Lifts</b>		
Platform Height	80 ft (24.38 m)	86 ft (26.21 m)
Platform Capacity—Restricted	1,000 lb (454 kg)	750 lb (340 kg)
Platform Capacity—Unrestricted	500 lb (227 kg)	500 lb (227 kg)
Horizontal Outreach	71 ft (21.64 m)	75 ft (22.9 m)
Overall Width	8 ft 2 in. (2.49 m)	8 ft 2 in. (2.49 m)
Weight <sup>1</sup>	33,200 lb (15,059 kg)	36,888 lb (16,732 kg)
Dual Fuel Engine—Ford MS6425-DF	84 hp (62.6 kW)	84 hp (62.6 kW)
Diesel Engine—Deutz TD2.9L4 Tier 4 Final	67 hp (50 kW)	67 hp (50 kW)
<b>Available Options</b>		
Light Package—Includes head and tail lights, platform worklights and beacon.	—	—
Tow Package	—	—
35 x 72 in. (0.91 x 1.83 m) Platform	—	—
Cold Weather Start Kit—Includes engine block heater, battery heater and oil tank heater.	—	—
Arctic Package <sup>2</sup>	—	—
Self-Closing Gate	—	—
SkySense™	—	—

<sup>1</sup> Certain options or country standards may increase weight.  
<sup>2</sup> Includes Arctic Hydraulic hoses (30-wire min only) and main boom cable, extreme cold engine oil, fuel conditioner, engine block heater, battery blanket, glow plugs, hydraulic tank heater, overwind footswitch and Arctic hydraulic oil.

# 450 SERIES

ARTICULATING BOOM LIFT

**JLG**  
reachingout®

## Performance

Platform Height	45 ft	13.72 m
Horizontal Outreach		
450A	30 ft	9.14 m
450AJ	25 ft	7.62 m
Up and Over Height	24 ft	7.3 m
Swing	355 Degrees Non-Continuous	
Platform Capacity		
Unrestricted	550 lb	250 kg
Platform Size	30 x 72 in.	0.76 x 1.83 m
Platform Rotator	180 Degrees Hydraulic	
Jib	4 ft 1 in.	1.24 m
Range of Articulation	145 Degrees (+76, -69)	
Weight		
450A	15,850 lb	7,190 kg
450AJ	14,150 lb	6,418 kg
Max Ground Bearing Pressure	65 psi	4.57 kg/cm <sup>2</sup>
Drive Speed	4.25 mph	6.84 km/hr
Gradeability		
2WD	30%	
4WD	45%	
Tilt Cut Out	5 Degrees	
Axle Oscillation	4 in.	10 cm
Turning Radius		
Inside	6 ft 9 in.	2.06 m
Outside	15 ft 8 in.	4.78 m

## Standard Specifications

### Power Source

Dual Fuel Engine		
Kubota WG2503	61 hp	45.5 kW
Diesel Engine		
Deutz D2.9 L4 Tier 4 Final	49 hp	36.4 kW
Fuel Tank Capacity	16 gal.	60.6 L

### Hydraulic System

System Capacity	38 gal.	143.8 L
Tank Capacity	36 gal.	136.27 L
Auxiliary Power	12V-DC	

### Tires

Standard	33/1550 x 16.5 Foam Filled Lug Tread	
Optional	Non Marking Foam Filled Tires	



## Standard Features

- 4 ft 1 in. (1.24 m) Articulating Jib
- Platform 30 x 72 in. (0.76 x 1.83 m) Side Entry
- 180 Degree Hydraulic Platform Rotator
- Platform Console Machine Status Light Panel<sup>1</sup>
- 110V-AC Receptacle in the Platform
- 5 Degree Tilt Alarm/Indicator Light
- Swing Out Engine Module
- Improved Multi-Function Controls
- Gull-Wing Turntable Hoods
- 12V-DC Auxiliary Power
- Hourmeter
- Interactive Display at Ground Controls
- Proportional Controls
- Control ADE® System
- Lifting/Tie Down Lugs
- Horn
- Four-Wheel Hydrostatic Drive
- Oscillating Axle
- Cast Aluminum Control Box
- Motion Alarm
- Reduced Time to Full Height
- Load Sensing System
- SkyGuard SkyLine™

## Accessories & Options

- 30 x 60 in. (0.76 x 1.25 m) Platform
- Inward Self-Closing Swing
- 36 x 72 in. (0.91 x 1.83 m) Platform
- Fall Arrest Platform 30 x 60 in. (.76 x 1.53 m)
- 1/2 in. Air Line to Platform
- SkySense™
- Soft Touch System
- AC Generator
- Flashing Amber Beacon
- 43.5 lb (19.73 kg) Propane Tank
- Cold Weather Kit<sup>2</sup>
- Hostile Environment Kit<sup>3</sup>
- Arctic Package<sup>4</sup>
- Light Package<sup>5</sup>
- Operator Tool Tray
- Accessory Packages
  - SkyPower® Package
  - SkyWelder® Package

1. Provides indicator lights at platform control console for system distress, low fuel, 5 degree tilt light, and foot switch status.
2. Includes battery blanket, hydraulic tank heater, block heater (GM), glow plugs (Deutz).
3. Includes boom wipers, cylinder bellows and console cover.
4. Includes arctic hydraulic hoses (drive and steer only) and main boom cable, extreme cold engine oil, fuel conditioner, engine block heater, battery blanket, glow plugs, hydraulic tank heater, and oversized footswitch.
5. Includes platform work lights, head and tail lights, amber beacon.

Note: Some options may increase lead time, and some option combinations may not be available. Additional accessories and options available via JLG Aftermarket.

# 450 SERIES

ARTICULATING BOOM LIFT



## Dimensions

All dimensions are approximate.

### 450A

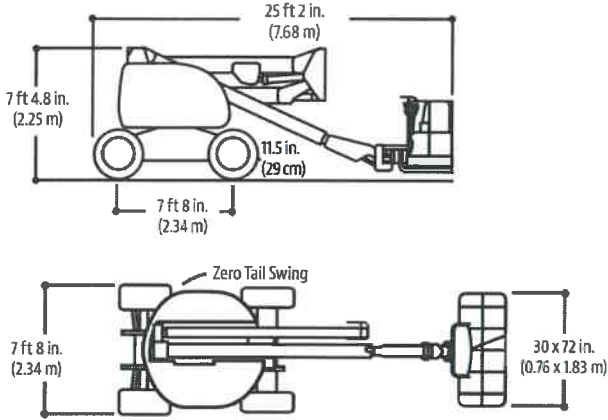

### 450AJ

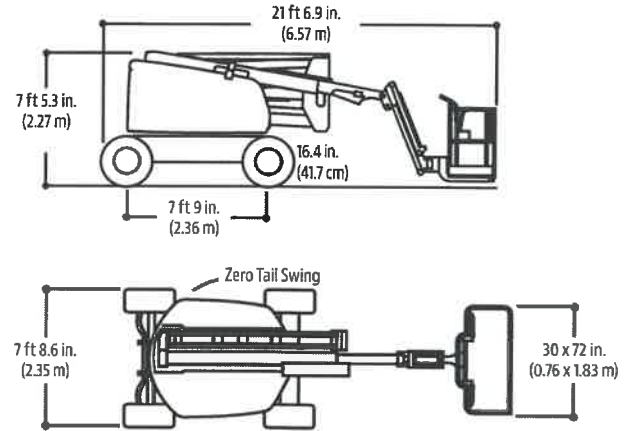

## Reach Diagrams

### 450A

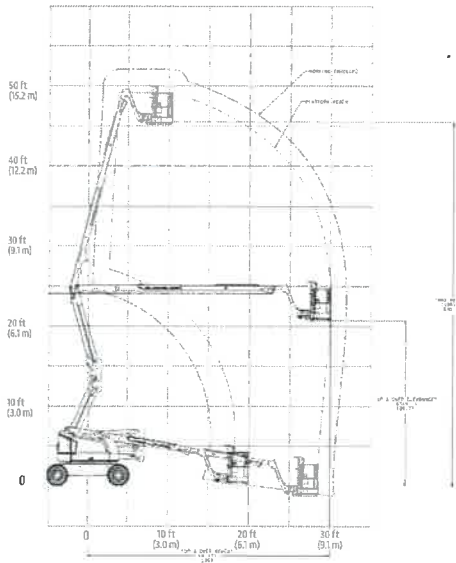

### 450AJ

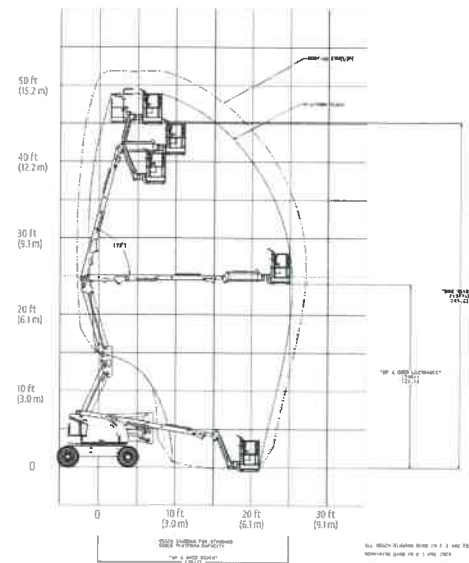

## The JLG "1 & 5" Warranty

We provide coverage for one (1) full year, and cover all specified major structural components for five (5) years. Due to continuous product improvements, we reserve the right to make specification and/or equipment changes without prior notification. This machine meets or exceeds applicable ANSI and CSA requirements based on machine configuration as originally manufactured for intended applications. Please reference the serial number plate on the machine for additional information.

Part No.: 3131117  
R1219\_A92.20  
Printed in USA



### JLG Industries, Inc.

1 JLG Drive  
McConnellsburg, PA 17233-9533  
Telephone 717-485-5161  
Toll-free in US 877-JLG-LIFT  
Fax 717-485-6417  
[www.jlg.com](http://www.jlg.com)

An Oshkosh Corporation Company

## JLG NEW PRODUCT WARRANTY NORTH AMERICA

JLG Industries, Inc. ("JLG") warrants its new products made by it to be free from defects in material or workmanship for twelve (12) months from the warranty start date.

In addition, JLG further warrants the structural elements of each new Boom Lift, Scissor Lift, Vertical Mast, Telehandler, Power Tower, Trailer and Trailer Boom (JLG LiftPod Product excluded) made by it, as defined in its then current warranty policies and procedures, to be free from defects in material or workmanship for five (5) years from the warranty start date.

JLG further warrants the powertrain of each of the new telescopic handlers made by it, as defined in its then current warranty policies and procedures, to be free from defects in material and workmanship for twenty-four (24) months or 2,000 hours-whichever occurs first.

JLG agrees only to repair or replace at its own expense, F.O.B. (E.X.W.), the place or places of manufacture, any part or parts of the product found to be defective in material or workmanship, provided JLG is notified of such defect or defects within the applicable warranty period and given a reasonable time to correct the defect. In no case shall any warranty extend to defects in materials, components, or services furnished by third parties. Defects caused by chemical action or the presence of abrasive materials and defects arising following the operation beyond rated capacity or the improper use or application of any products shall not be considered defects within the scope of this warranty. If any repairs or alterations are made or any parts are replaced during the applicable warranty periods by anyone other than JLG or an entity authorized by JLG in accordance with authorized JLG service manuals or with parts, accessories, or attachments other than authorized by JLG for use in its products, customer shall pay for such repairs or parts without recourse against JLG, and JLG shall be relieved of responsibility for fulfillment of this warranty with respect to such repairs, alterations, or replacements so made. JLG's obligations under this warranty shall at all times be subject to its then current warranty policies and procedures. The above mentioned warranty shall not apply to replacement or service parts made and sold to a customer by JLG. Routine maintenance, routine maintenance items (including paint and decals), and minor adjustments are excluded from this warranty. Certain components, including, but not limited to, engines, tires and batteries, which may be a part of the product are not manufactured or warranted by JLG. Any applicable warranty for such components is provided through the original manufacturer of the component or its distributor organization.

JLG further warrants that each unit is designed, built and equipped to meet United States Environmental Protection Agency ("EPA") and, where applicable, California Air Resources Board ("CARB") emissions requirements in effect on the date of manufacture. JLG further warrants that the unit is free from defects in material and workmanship that might prevent the unit from meeting applicable EPA and CARB requirements. Policy holders may obtain such emissions warranty service at no cost, including parts, labor and diagnostic services, for their equipment from an authorized JLG Servicer or any authorized servicer of the Engine OEM. Please also note that this Emissions Control System Warranty is required by EPA, and in certain equipment applications, by CARB, and is a distinct and additional warranty from the general commercial warranty described herein that JLG and its engine suppliers provide to customers who purchase JLG equipment and associated engines. Please refer to the "JLG Emissions Warranty Guidelines", available for download at [www.JLG.com](http://www.JLG.com), for additional details specific to your machine. End users may also perform their own repairs of emissions-related components, although the cost of labor and diagnostic services provided by other than an authorized JLG servicer or OEM are outside the scope of this warranty and will not be paid for by JLG free of charge. The proper

performance of routine maintenance by the customer or a third party service shall not invalidate this emissions warranty.

## **JLG NEW PRODUCT WARRANTY NORTH AMERICA**

JLG Warranty Policy covers Parts, Labor, and Travel costs as outlined in JLG's then current warranty policies and procedures. JLG LiftPod Product is excluded from Travel coverage.

JLG Warranty Policy does not cover any duties, taxes, environmental fees, including without limitation, disposal or handling of tires, batteries, and petrochemical items.

Under no circumstances shall JLG be liable for any consequential or special damages which any person or entity may incur or claim to incur as a result of any defect in the product or in any correction or alteration thereof made or furnished by JLG or others. "Consequential" or "special damage" includes, but is not limited to costs of transportation, lost sales, lost orders, lost profits, lost income, increased overhead, labor and material costs, and cost of manufacturing variances and operational inefficiencies. JLG's maximum liability under this warranty shall be the purchase price paid to JLG with respect to the product to which such warranty is claimed. The limitation of liability provisions herein shall apply to any and all claims or suits brought against JLG, including any claim based upon negligence, breach of contract, breach of warranty, strict liability or any other theories upon which liability may be asserted against JLG.

This warranty constitutes JLG's entire and exclusive warranty as to the product and is the sole and exclusive remedy for product defects in material and workmanship. JLG does not assume (and has not authorized any other person to assume on its behalf) any other warranty or liability in connection with any product covered by this warranty. **JLG EXPRESSLY DISCLAIMS ANY AND ALL OTHER WARRANTIES OF ANY KIND WHATSOEVER AS TO THE PRODUCT FURNISHED HEREUNDER, INCLUDING BUT NOT LIMITED TO ANY EXPRESS WARRANTIES, EXCEPT FOR THE EXCLUSIVE WARRANTY PROVIDED HEREIN, OR IMPLIED WARRANTIES AS TO MERCHANTABILITY, OR FITNESS FOR ANY PARTICULAR PURPOSE.**

This warranty shall be void, if, upon the occurrence of any incident involving any product made by JLG and resulting in any personal injury or property damage, customer shall fail to notify JLG within 48 hours of such occurrence or permit JLG and its representatives to have immediate access to such product and all records of or within the control of customer relating to the product and occurrence.