



Department of Administration
 Purchasing Division
 2019 Washington Street East
 Post Office Box 50130
 Charleston, WV 25305-0130

State of West Virginia
 Centralized Request for Quote
 Equipment

Proc Folder: 821234			Reason for Modification: Addendum #1 issued to publish agency responses to all vendor questions.
Doc Description: Compact Track Loader with Attachments			
Proc Type: Central Purchase Order			
Date Issued	Solicitation Closes	Solicitation No	Version
2021-02-23	2021-02-25 13:30	CRFQ 0313 DEP2100000020	2

BID RECEIVING LOCATION

BID CLERK
 DEPARTMENT OF ADMINISTRATION
 PURCHASING DIVISION
 2019 WASHINGTON ST E
 CHARLESTON WV 25305
 US

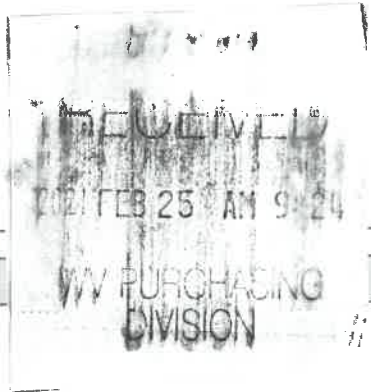

VENDOR

Vendor Customer Code: 201670
Vendor Name: Leslie Equipment Co.
Address: 19 Goff Crossing Drive
Street:
City: Cross Lanes
State: WV **Country:** US **Zip:** 25313
Principal Contact: Paul Daniels
Vendor Contact Phone: 304-204-1818 **Extension:**

FOR INFORMATION CONTACT THE BUYER
 Joseph E Hager III
 (304) 558-2306
 joseph.e.hageriii@wv.gov

Vendor Signature X *Paul Daniels* **FEIN#** 55-0493180 **DATE** 2-24-2021

All offers subject to all terms and conditions contained in this solicitation

ADDITIONAL INFORMATION

Addendum

Addendum #1 issued to publish the attached documentation to the vendor community.

The West Virginia Purchasing Division is soliciting bids on behalf of the West Virginia Department of Environmental Protection (WVDEP), Rehabilitation Environmental Action Plan (REAP), to establish a one-time purchase of one (1) Compact Track Loader or Equal and the associated listed attachments, per the attached specifications and terms and conditions.

INVOICE TO	SHIP TO
ENVIRONMENTAL PROTECTION REAP OFFICE 601 57TH ST SE CHARLESTON WV 25304 US	ENVIRONMENTAL PROTECTION REAP OFFICE 601 57TH ST SE CHARLESTON WV 25304 US

Line	Comm Ln Desc	Qty	Unit Issue	Unit Price	Total Price
1	Compact Track Loader with Attachments	1.00000	EA	<i>\$57,350.⁰⁰</i>	<i>\$57,350.⁰⁰</i>

Comm Code	Manufacturer	Specification	Model #
22101532	<i>John Deere</i>	<i>Compact track loader</i>	<i>325G</i>

Extended Description:

Compact Track Loader with Attachments, as listed in attached specifications.

SCHEDULE OF EVENTS

<u>Line</u>	<u>Event</u>	<u>Event Date</u>
-------------	--------------	-------------------

SOLICITATION NUMBER: CRFQ 0313 DEP2100000020

Addendum Number: No.01

The purpose of this addendum is to modify the solicitation identified as (“Solicitation”) to reflect the change(s) identified and described below.

Applicable Addendum Category:

- Modify bid opening date and time
- Modify specifications of product or service being sought
- Attachment of vendor questions and responses
- Attachment of pre-bid sign-in sheet
- Correction of error
- Other

Description of Modification to Solicitation:

Addendum issued to publish and distribute the attached documentation to the vendor community.

1. Issue agency responses to all vendor submitted questions

Additional Documentation: Documentation related to this Addendum (if any) has been included herewith as Attachment A and is specifically incorporated herein by reference.

Terms and Conditions:

1. All provisions of the Solicitation and other addenda not modified herein shall remain in full force and effect.
2. Vendor should acknowledge receipt of all addenda issued for this Solicitation by completing an Addendum Acknowledgment, a copy of which is included herewith. Failure to acknowledge addenda may result in bid disqualification. The addendum acknowledgement should be submitted with the bid to expedite document processing.

State of West Virginia

VENDOR PREFERENCE CERTIFICATE

Certification and application is hereby made for Preference in accordance with **West Virginia Code**, §5A-3-37. (Does not apply to construction contracts). **West Virginia Code**, §5A-3-37, provides an opportunity for qualifying vendors to request (at the time of bid) preference for their residency status. Such preference is an evaluation method only and will be applied only to the cost bid in accordance with the **West Virginia Code**. This certificate for application is to be used to request such preference. The Purchasing Division will make the determination of the Vendor Preference, if applicable.

1. Application is made for 2.5% vendor preference for the reason checked:

Bidder is an individual resident vendor and has resided continuously in West Virginia, or bidder is a partnership, association or corporation resident vendor and has maintained its headquarters or principal place of business continuously in West Virginia, for four (4) years immediately preceding the date of this certification; **or**,

Bidder is a resident vendor partnership, association, or corporation with at least eighty percent of ownership interest of bidder held by another entity that meets the applicable four year residency requirement; **or**,

Bidder is a nonresident vendor which has an affiliate or subsidiary which employs a minimum of one hundred state residents and which has maintained its headquarters or principal place of business within West Virginia continuously for the four (4) years immediately preceding the date of this certification; **or**,

2. Application is made for 2.5% vendor preference for the reason checked:

Bidder is a resident vendor who certifies that, during the life of the contract, on average at least 75% of the employees working on the project being bid are residents of West Virginia who have resided in the state continuously for the two years immediately preceding submission of this bid; **or**,

3. Application is made for 2.5% vendor preference for the reason checked:

Bidder is a nonresident vendor that employs a minimum of one hundred state residents, or a nonresident vendor which has an affiliate or subsidiary which maintains its headquarters or principal place of business within West Virginia and employs a minimum of one hundred state residents, and for purposes of producing or distributing the commodities or completing the project which is the subject of the bidder's bid and continuously over the entire term of the project, on average at least seventy-five percent of the bidder's employees or the bidder's affiliate's or subsidiary's employees are residents of West Virginia who have resided in the state continuously for the two immediately preceding years and the vendor's bid; **or**,

4. Application is made for 5% vendor preference for the reason checked:

Bidder meets either the requirement of both subdivisions (1) and (2) or subdivision (1) and (3) as stated above; **or**,

5. Application is made for 3.5% vendor preference who is a veteran for the reason checked:

Bidder is an individual resident vendor who is a veteran of the United States armed forces, the reserves or the National Guard and has resided in West Virginia continuously for the four years immediately preceding the date on which the bid is submitted; **or**,

6. Application is made for 3.5% vendor preference who is a veteran for the reason checked:

Bidder is a resident vendor who is a veteran of the United States armed forces, the reserves or the National Guard, if, for purposes of producing or distributing the commodities or completing the project which is the subject of the vendor's bid and continuously over the entire term of the project, on average at least seventy-five percent of the vendor's employees are residents of West Virginia who have resided in the state continuously for the two immediately preceding years.

7. Application is made for preference as a non-resident small, women- and minority-owned business, in accordance with West Virginia Code §5A-3-59 and West Virginia Code of State Rules.

Bidder has been or expects to be approved prior to contract award by the Purchasing Division as a certified small, women- and minority-owned business.

8. Application is made for reciprocal preference.

Bidder is a West Virginia resident and is requesting reciprocal preference to the extent that it applies.

Bidder understands if the Secretary of Revenue determines that a Bidder receiving preference has failed to continue to meet the requirements for such preference, the Secretary may order the Director of Purchasing to: (a) rescind the contract or purchase order; or (b) assess a penalty against such Bidder in an amount not to exceed 5% of the bid amount and that such penalty will be paid to the contracting agency or deducted from any unpaid balance on the contract or purchase order.

By submission of this certificate, Bidder agrees to disclose any reasonably requested information to the Purchasing Division and authorizes the Department of Revenue to disclose to the Director of Purchasing appropriate information verifying that Bidder has paid the required business taxes, provided that such information does not contain the amounts of taxes paid nor any other information deemed by the Tax Commissioner to be confidential.

Bidder hereby certifies that this certificate is true and accurate in all respects; and that if a contract is issued to Bidder and if anything contained within this certificate changes during the term of the contract, Bidder will notify the Purchasing Division in writing immediately.

Bidder: LESLIE EQUIPMENT CO.

Signed 

Date: 2/24/2021

Title: MANAGER

*Check any combination of preference consideration(s) indicated above, which you are entitled to receive.

ATTACHMENT A

ADDENDUM ACKNOWLEDGEMENT FORM
SOLICITATION NO.: CRFQ DEP21*20

Instructions: Please acknowledge receipt of all addenda issued with this solicitation by completing this addendum acknowledgment form. Check the box next to each addendum received and sign below. Failure to acknowledge addenda may result in bid disqualification.

Acknowledgment: I hereby acknowledge receipt of the following addenda and have made the necessary revisions to my proposal, plans and/or specification, etc.

Addendum Numbers Received:

(Check the box next to each addendum received)

- | | |
|--|--|
| <input checked="" type="checkbox"/> Addendum No. 1 | <input type="checkbox"/> Addendum No. 6 |
| <input type="checkbox"/> Addendum No. 2 | <input type="checkbox"/> Addendum No. 7 |
| <input type="checkbox"/> Addendum No. 3 | <input type="checkbox"/> Addendum No. 8 |
| <input type="checkbox"/> Addendum No. 4 | <input type="checkbox"/> Addendum No. 9 |
| <input type="checkbox"/> Addendum No. 5 | <input type="checkbox"/> Addendum No. 10 |

I understand that failure to confirm the receipt of addenda may be cause for rejection of this bid. I further understand that any verbal representation made or assumed to be made during any oral discussion held between Vendor's representatives and any state personnel is not binding. Only the information issued in writing and added to the specifications by an official addendum is binding.

Leslie Equipment Co.

Company

Paul Daniels

Authorized Signature

2-24-2021

Date

NOTE: This addendum acknowledgment should be submitted with the bid to expedite document processing.

Revised 6/8/2012

CRFQ DEP21*20
Compact Track Load with Attachments
Vendor Questions with Responses

Q.1. 3.1.1.2 Unit shall have a minimum operating weight of 8,000 pounds and a maximum operating weight of 8,500 pounds including grapple bucket.

- The CAT 259D3 has a base operating weight of 8,987 pounds. After adding the grapple bucket and additional counterweight necessary, our machine will weigh around 9,250 pounds. The biggest reason for this is the difference in the undercarriage on the CAT machine. The CAT compact track loaders utilize a true bogie style undercarriage (similar to a CAT dozer). It is much more rugged and heavy duty in comparison to the cage type system that is on an ASV machine. This more robust undercarriage does add some weight to the overall weight of the machine. The tracks are also steel embedded which adds a little bit more weight as well. We would like to request that the operating weight requirement be adjusted to a maximum weight of 9,500 pounds.

A. No, the maximum operating weight will remain at 8,500 pounds due to transport constraints.

Q.2. 3.1.5.1.3 Must have track guides to prevent track misalignment.

- The undercarriage on the CAT 259D3, as stated above, is a different style undercarriage. As such, it does not use separate track guides. The tracks are held in place and guided by the flanges on the idlers on the machines. We would like to request that this spec be changed to include other measures of track guiding.

A. Yes, the flanged idlers are an acceptable track guide system that will prevent track misalignment.

Q.3. 3.1.6.6.8 Rearview Mirror

- The CAT 259D3 does have a rearview mirror. It also comes standard with a backup camera. The backup camera is a critical feature for visibility and safe machine operation, especially in tight environments. We would like to request that a backup camera be required.

A. A rearview mirror meets the specifications.

Q.4. 3.1.7.1 Unit bid shall have minimum height to bucket pin of 126 inches.

- The CAT 259D3 has a bucket pin height of 121 inches. We would like to request that this spec be lowered to accept 121 inches.

A. A bucket pin height of 126 inches is required for our loading requirements; therefore, specification will not be revised.

Q.5. 3.1.8.1 Unit shall have a minimum rated operating capacity (35% of tipping load) of 2300 pounds.

- The CAT 259D3 has a rated operating capacity (35% tipping load) of 2142 pounds with the optional additional counterweights. We would like to request that this spec be lowered to 2142 pounds.

A. The requirement of 2300 pounds @ 35% of tipping load is required due to operating requirements ; therefore, specification will not be revised.

Q.6. 3.1.9.1 Unit should include a 66-inch construction/scrap grapple bucket with two (2) individual grapples.

- The Caterpillar grapple bucket is a 68 inch bucket. Would that be acceptable?

A. Yes, a 68-inch bucket would be acceptable. Specification should be modified to read as: 3.1.9.1 Unit should include a minimum 66-inch construction/grapple bucket with two (2) individual grapples.

Q.7. 3.1.1.2 Is an operating weight of 9,039 lbs. acceptable.

A. No, see Q1 and A1.

Q.8. 3.1.5.1.1 Would a rigid mounted suspension be acceptable. Fewer moving parts, less cost to repair, more durable.

A. No, torsion bar suspension is required due to operating conditions.

Q.9. 3.1.5.1.3 Would triple flanged lower track rollers be acceptable in lieu of track guides to prevent track misalignment.

A. Yes, see Q2 and A2

Q.10. 3.1.5.1.5 Is 56.5" minimum track length on ground acceptable.

A. No, we need a minimum track length of 59 inches due to stability requirements.

Q.11. 3.1.7 Is a minimum hinge pin height of 119.1" acceptable.

A. No, see Q4 and A4

Q.12. 3.1.9.1 Is a 68" width grapple bucket acceptable.

A. Yes, see Q6 & A6.



Department of Administration
 Purchasing Division
 2019 Washington Street East
 Post Office Box 50130
 Charleston, WV 25305-0130

State of West Virginia
 Centralized Request for Quote
 Equipment

Proc Folder: 821234		Reason for Modification:	
Doc Description: Compact Track Loader with Attachments			
Proc Type: Central Purchase Order			
Date Issued	Solicitation Closes	Solicitation No	Version
2021-02-09	2021-02-25 13:30	CRFQ 0313 DEP2100000020	1

BID RECEIVING LOCATION

BID CLERK
 DEPARTMENT OF ADMINISTRATION
 PURCHASING DIVISION
 2019 WASHINGTON ST E
 CHARLESTON WV 25305
 US

VENDOR

Vendor Customer Code: *201670*
 Vendor Name: *Leslie Equipment Co*
 Address: *19 Goff Crossing Drive*
 Street:
 City: *Cross Lanes*
 State: *WV* Country: *US* Zip: *25313*
 Principal Contact: *Paul Daniels*
 Vendor Contact Phone: *304-204-1888* Extension:

FOR INFORMATION CONTACT THE BUYER
 Joseph E Hager III
 (304) 558-2306
 joseph.e.hageriii@wv.gov

Vendor Signature X *Paul Daniels* FEIN# *55-0493180* DATE *2-24-2021*

All offers subject to all terms and conditions contained in this solicitation

ADDITIONAL INFORMATION

The West Virginia Purchasing Division is soliciting bids on behalf of the West Virginia Department of Environmental Protection (WVDEP), Rehabilitation Environmental Action Plan (REAP), to establish a one-time purchase of one (1) Compact Track Loader or Equal and the associated listed attachments, per the attached specifications and terms and conditions.

INVOICE TO

ENVIRONMENTAL PROTECTION
 REAP OFFICE
 601 57TH ST SE
 CHARLESTON WV 25304
 US

SHIP TO

ENVIRONMENTAL PROTECTION
 REAP OFFICE
 601 57TH ST SE
 CHARLESTON WV 25304
 US

Line	Comm Ln Desc	Qty	Unit Issue	Unit Price	Total Price
1	Compact Track Loader with Attachments	1.00000	EA	<i>\$57,350.00</i>	<i>\$57,350.00</i>

Comm Code	Manufacturer	Specification	Model #
22101532	<i>John Deere</i>	<i>Compact track loader</i>	<i>3256</i>

Extended Description:

Compact Track Loader with Attachments, as listed in attached specifications.

SCHEDULE OF EVENTS

<u>Line</u>	<u>Event</u>	<u>Event Date</u>
-------------	--------------	-------------------

INSTRUCTIONS TO VENDORS SUBMITTING BIDS

1. REVIEW DOCUMENTS THOROUGHLY: The attached documents contain a solicitation for bids. Please read these instructions and all documents attached in their entirety. These instructions provide critical information about requirements that if overlooked could lead to disqualification of a Vendor's bid. All bids must be submitted in accordance with the provisions contained in these instructions and the Solicitation. Failure to do so may result in disqualification of Vendor's bid.

2. MANDATORY TERMS: The Solicitation may contain mandatory provisions identified by the use of the words "must," "will," and "shall." Failure to comply with a mandatory term in the Solicitation will result in bid disqualification.

3. PREBID MEETING: The item identified below shall apply to this Solicitation.

A pre-bid meeting will not be held prior to bid opening

A MANDATORY PRE-BID meeting will be held at the following place and time:

All Vendors submitting a bid must attend the mandatory pre-bid meeting. Failure to attend the mandatory pre-bid meeting shall result in disqualification of the Vendor's bid. No one individual is permitted to represent more than one vendor at the pre-bid meeting. Any individual that does attempt to represent two or more vendors will be required to select one vendor to which the individual's attendance will be attributed. The vendors not selected will be deemed to have not attended the pre-bid meeting unless another individual attended on their behalf.

An attendance sheet provided at the pre-bid meeting shall serve as the official document verifying attendance. Any person attending the pre-bid meeting on behalf of a Vendor must list on the attendance sheet his or her name and the name of the Vendor he or she is representing.

Additionally, the person attending the pre-bid meeting should include the Vendor's E-Mail address, phone number, and Fax number on the attendance sheet. It is the Vendor's responsibility to locate the attendance sheet and provide the required information. Failure to complete the attendance sheet as required may result in disqualification of Vendor's bid.

All Vendors should arrive prior to the starting time for the pre-bid. Vendors who arrive after the starting time but prior to the end of the pre-bid will be permitted to sign in but are charged with knowing all matters discussed at the pre-bid.

Questions submitted at least five business days prior to a scheduled pre-bid will be discussed at the pre-bid meeting if possible. Any discussions or answers to questions at the pre-bid meeting
Revised 01/09/2020

are preliminary in nature and are non-binding. Official and binding answers to questions will be published in a written addendum to the Solicitation prior to bid opening.

4. VENDOR QUESTION DEADLINE: Vendors may submit questions relating to this Solicitation to the Purchasing Division. Questions must be submitted in writing. All questions must be submitted on or before the date listed below and to the address listed below in order to be considered. A written response will be published in a Solicitation addendum if a response is possible and appropriate. Non-written discussions, conversations, or questions and answers regarding this Solicitation are preliminary in nature and are nonbinding.

Submitted e-mails should have solicitation number in the subject line.

Question Submission Deadline: 02/18/2021 @ 4:00 PM ET

Submit Questions to: Josh Hager
2019 Washington Street, East
Charleston, WV 25305
Fax: (304) 558-4115 (Vendors should not use this fax number for bid submission)
Email: Joseph.E.HagerIII@wv.gov

5. VERBAL COMMUNICATION: Any verbal communication between the Vendor and any State personnel is not binding, including verbal communication at the mandatory pre-bid conference. Only information issued in writing and added to the Solicitation by an official written addendum by the Purchasing Division is binding.

6. BID SUBMISSION: All bids must be submitted electronically through wvOASIS or signed and delivered by the Vendor to the Purchasing Division at the address listed below on or before the date and time of the bid opening. Any bid received by the Purchasing Division staff is considered to be in the possession of the Purchasing Division and will not be returned for any reason. The Purchasing Division will not accept bids, modification of bids, or addendum acknowledgment forms via e-mail. Acceptable delivery methods include electronic submission via wvOASIS, hand delivery, delivery by courier, or facsimile.

The bid delivery address is:
Department of Administration, Purchasing Division
2019 Washington Street East
Charleston, WV 25305-0130

A bid that is not submitted electronically through wvOASIS should contain the information listed below on the face of the envelope or the bid may be rejected by the Purchasing Division.:

SEALED BID: Hydraulic Compact Track Excavator
BUYER: Josh Hager
SOLICITATION NO.: CRFQ DEP 0313 210000020
BID OPENING DATE: See next page
BID OPENING TIME: See next page
FAX NUMBER: 304-558-3970

Revised 01/09/2020

The Purchasing Division may prohibit the submission of bids electronically through wvOASIS at its sole discretion. Such a prohibition will be contained and communicated in the wvOASIS system resulting in the Vendor's inability to submit bids through wvOASIS. Submission of a response to an Expression or Interest or Request for Proposal is not permitted in wvOASIS.

For Request For Proposal ("RFP") Responses Only: In the event that Vendor is responding to a request for proposal, the Vendor shall submit one original technical and one original cost proposal plus NA convenience copies of each to the Purchasing Division at the address shown above. Additionally, the Vendor should identify the bid type as either a technical or cost proposal on the face of each bid envelope submitted in response to a request for proposal as follows:

BID TYPE: (This only applies to CRFP)

Technical

Cost

7. BID OPENING: Bids submitted in response to this Solicitation will be opened at the location identified below on the date and time listed below. Delivery of a bid after the bid opening date and time will result in bid disqualification. For purposes of this Solicitation, a bid is considered delivered when confirmation of delivery is provided by wvOASIS (in the case of electronic submission) or when the bid is time stamped by the official Purchasing Division time clock (in the case of hand delivery).

Bid Opening Date and Time: 02/25/2021 @ 1:30 PM ET

Bid Opening Location: Department of Administration, Purchasing Division
2019 Washington Street East
Charleston, WV 25305-0130

8. ADDENDUM ACKNOWLEDGEMENT: Changes or revisions to this Solicitation will be made by an official written addendum issued by the Purchasing Division. Vendor should acknowledge receipt of all addenda issued with this Solicitation by completing an Addendum Acknowledgment Form, a copy of which is included herewith. Failure to acknowledge addenda may result in bid disqualification. The addendum acknowledgement should be submitted with the bid to expedite document processing.

9. BID FORMATTING: Vendor should type or electronically enter the information onto its bid to prevent errors in the evaluation. Failure to type or electronically enter the information may result in bid disqualification.

10. ALTERNATE MODEL OR BRAND: Unless the box below is checked, any model, brand, or specification listed in this Solicitation establishes the acceptable level of quality only and is not intended to reflect a preference for, or in any way favor, a particular brand or vendor. Vendors may bid alternates to a listed model or brand provided that the alternate is at least equal to the model or brand and complies with the required specifications. The equality of any alternate being bid shall be determined by the State at its sole discretion. Any Vendor bidding an alternate model or brand should clearly identify the alternate items in its bid and should include manufacturer's specifications, industry literature, and/or any other relevant documentation demonstrating the

equality of the alternate items. Failure to provide information for alternate items may be grounds for rejection of a Vendor's bid.

This Solicitation is based upon a standardized commodity established under W. Va. Code § 5A-3-61. Vendors are expected to bid the standardized commodity identified. Failure to bid the standardized commodity will result in your firm's bid being rejected.

11. EXCEPTIONS AND CLARIFICATIONS: The Solicitation contains the specifications that shall form the basis of a contractual agreement. Vendor shall clearly mark any exceptions, clarifications, or other proposed modifications in its bid. Exceptions to, clarifications of, or modifications of a requirement or term and condition of the Solicitation may result in bid disqualification.

12. COMMUNICATION LIMITATIONS: In accordance with West Virginia Code of State Rules §148-1-6.6, communication with the State of West Virginia or any of its employees regarding this Solicitation during the solicitation, bid, evaluation or award periods, except through the Purchasing Division, is strictly prohibited without prior Purchasing Division approval. Purchasing Division approval for such communication is implied for all agency delegated and exempt purchases.

13. REGISTRATION: Prior to Contract award, the apparent successful Vendor must be properly registered with the West Virginia Purchasing Division and must have paid the \$125 fee, if applicable.

14. UNIT PRICE: Unit prices shall prevail in cases of a discrepancy in the Vendor's bid.

15. PREFERENCE: Vendor Preference may be requested in purchases of motor vehicles or construction and maintenance equipment and machinery used in highway and other infrastructure projects. Any request for preference must be submitted in writing with the bid, must specifically identify the preference requested with reference to the applicable subsection of West Virginia Code § 5A-3-37, and must include with the bid any information necessary to evaluate and confirm the applicability of the requested preference. A request form to help facilitate the request can be found at:

<http://www.state.wv.us/admin/purchase/vrc/Venpref.pdf>.

15A. RECIPROCAL PREFERENCE: The State of West Virginia applies a reciprocal preference to all solicitations for commodities and printing in accordance with W. Va. Code § 5A-3-37(b). In effect, non-resident vendors receiving a preference in their home states, will see that same preference granted to West Virginia resident vendors bidding against them in West Virginia. Any request for reciprocal preference must include with the bid any information necessary to evaluate and confirm the applicability of the preference. A request form to help facilitate the request can be found at: <http://www.state.wv.us/admin/purchase/vrc/Venpref.pdf>.

16. SMALL, WOMEN-OWNED, OR MINORITY-OWNED BUSINESSES: For any solicitations publicly advertised for bid, in accordance with West Virginia Code §5A-3-37(a)(7) and W. Va. CSR § 148-22-9, any non-resident vendor certified as a small, women-owned, or minority-owned business under W. Va. CSR § 148-22-9 shall be provided the same preference made available to any resident vendor. Any non-resident small, women-owned, or

minority-owned business must identify itself as such in writing, must submit that writing to the Purchasing Division with its bid, and must be properly certified under W. Va. CSR § 148-22-9 prior to contract award to receive the preferences made available to resident vendors. Preference for a non-resident small, women-owned, or minority owned business shall be applied in accordance with W. Va. CSR § 148-22-9.

17. WAIVER OF MINOR IRREGULARITIES: The Director reserves the right to waive minor irregularities in bids or specifications in accordance with West Virginia Code of State Rules § 148-1-4.6.

18. ELECTRONIC FILE ACCESS RESTRICTIONS: Vendor must ensure that its submission in wvOASIS can be accessed and viewed by the Purchasing Division staff immediately upon bid opening. The Purchasing Division will consider any file that cannot be immediately accessed and viewed at the time of the bid opening (such as, encrypted files, password protected files, or incompatible files) to be blank or incomplete as context requires, and are therefore unacceptable. A vendor will not be permitted to unencrypt files, remove password protections, or resubmit documents after bid opening to make a file viewable if those documents are required with the bid. A Vendor may be required to provide document passwords or remove access restrictions to allow the Purchasing Division to print or electronically save documents provided that those documents are viewable by the Purchasing Division prior to obtaining the password or removing the access restriction.

19. NON-RESPONSIBLE: The Purchasing Division Director reserves the right to reject the bid of any vendor as Non-Responsible in accordance with W. Va. Code of State Rules § 148-1-5.3, when the Director determines that the vendor submitting the bid does not have the capability to fully perform, or lacks the integrity and reliability to assure good-faith performance.”

20. ACCEPTANCE/REJECTION: The State may accept or reject any bid in whole, or in part in accordance with W. Va. Code of State Rules § 148-1-4.5. and § 148-1-6.4.b.”

21. YOUR SUBMISSION IS A PUBLIC DOCUMENT: Vendor’s entire response to the Solicitation and the resulting Contract are public documents. As public documents, they will be disclosed to the public following the bid/proposal opening or award of the contract, as required by the competitive bidding laws of West Virginia Code §§ 5A-3-1 et seq., 5-22-1 et seq., and 5G-1-1 et seq. and the Freedom of Information Act West Virginia Code §§ 29B-1-1 et seq.

DO NOT SUBMIT MATERIAL YOU CONSIDER TO BE CONFIDENTIAL, A TRADE SECRET, OR OTHERWISE NOT SUBJECT TO PUBLIC DISCLOSURE.

Submission of any bid, proposal, or other document to the Purchasing Division constitutes your explicit consent to the subsequent public disclosure of the bid, proposal, or document. The Purchasing Division will disclose any document labeled “confidential,” “proprietary,” “trade secret,” “private,” or labeled with any other claim against public disclosure of the documents, to include any “trade secrets” as defined by West Virginia Code § 47-22-1 et seq. All submissions are subject to public disclosure without notice.

22. INTERESTED PARTY DISCLOSURE: West Virginia Code § 6D-1-2 requires that the vendor submit to the Purchasing Division a disclosure of interested parties to the contract for all contracts with an actual or estimated value of at least \$1 Million. That disclosure must occur on the form prescribed and approved by the WV Ethics Commission prior to contract award. A copy of that form is included with this solicitation or can be obtained from the WV Ethics Commission. This requirement does not apply to publicly traded companies listed on a national or international stock exchange. A more detailed definition of interested parties can be obtained from the form referenced above.

23. WITH THE BID REQUIREMENTS: In instances where these specifications require documentation or other information with the bid, and a vendor fails to provide it with the bid, the Director of the Purchasing Division reserves the right to request those items after bid opening and prior to contract award pursuant to the authority to waive minor irregularities in bids or specifications under W. Va. CSR § 148-1-4.6. This authority does not apply to instances where state law mandates receipt with the bid.

GENERAL TERMS AND CONDITIONS:

1. CONTRACTUAL AGREEMENT: Issuance of a Award Document signed by the Purchasing Division Director, or his designee, and approved as to form by the Attorney General's office constitutes acceptance of this Contract made by and between the State of West Virginia and the Vendor. Vendor's signature on its bid signifies Vendor's agreement to be bound by and accept the terms and conditions contained in this Contract.

2. DEFINITIONS: As used in this Solicitation/Contract, the following terms shall have the meanings attributed to them below. Additional definitions may be found in the specifications included with this Solicitation/Contract.

2.1. "Agency" or "Agencies" means the agency, board, commission, or other entity of the State of West Virginia that is identified on the first page of the Solicitation or any other public entity seeking to procure goods or services under this Contract.

2.2. "Bid" or "Proposal" means the vendors submitted response to this solicitation.

2.3. "Contract" means the binding agreement that is entered into between the State and the Vendor to provide the goods or services requested in the Solicitation.

2.4. "Director" means the Director of the West Virginia Department of Administration, Purchasing Division.

2.5. "Purchasing Division" means the West Virginia Department of Administration, Purchasing Division.

2.6. "Award Document" means the document signed by the Agency and the Purchasing Division, and approved as to form by the Attorney General, that identifies the Vendor as the contract holder.

2.7. "Solicitation" means the official notice of an opportunity to supply the State with goods or services that is published by the Purchasing Division.

2.8. "State" means the State of West Virginia and/or any of its agencies, commissions, boards, etc. as context requires.

2.9. "Vendor" or "Vendors" means any entity submitting a bid in response to the Solicitation, the entity that has been selected as the lowest responsible bidder, or the entity that has been awarded the Contract as context requires.

3. CONTRACT TERM; RENEWAL; EXTENSION: The term of this Contract shall be determined in accordance with the category that has been identified as applicable to this Contract below:

Term Contract

Initial Contract Term: This Contract becomes effective on _____ and extends for a period of _____ year(s).

Renewal Term: This Contract may be renewed upon the mutual written consent of the Agency, and the Vendor, with approval of the Purchasing Division and the Attorney General's office (Attorney General approval is as to form only). Any request for renewal should be delivered to the Agency and then submitted to the Purchasing Division thirty (30) days prior to the expiration date of the initial contract term or appropriate renewal term. A Contract renewal shall be in accordance with the terms and conditions of the original contract. Unless otherwise specified below, renewal of this Contract is limited to _____ successive one (1) year periods or multiple renewal periods of less than one year, provided that the multiple renewal periods do not exceed the total number of months available in all renewal years combined. Automatic renewal of this Contract is prohibited. Renewals must be approved by the Vendor, Agency, Purchasing Division and Attorney General's office (Attorney General approval is as to form only)

Alternate Renewal Term – This contract may be renewed for _____ successive _____ year periods or shorter periods provided that they do not exceed the total number of months contained in all available renewals. Automatic renewal of this Contract is prohibited. Renewals must be approved by the Vendor, Agency, Purchasing Division and Attorney General's office (Attorney General approval is as to form only)

Delivery Order Limitations: In the event that this contract permits delivery orders, a delivery order may only be issued during the time this Contract is in effect. Any delivery order issued within one year of the expiration of this Contract shall be effective for one year from the date the delivery order is issued. No delivery order may be extended beyond one year after this Contract has expired.

Fixed Period Contract: This Contract becomes effective upon Vendor's receipt of the notice to proceed and must be completed within _____ days.

Fixed Period Contract with Renewals: This Contract becomes effective upon Vendor's receipt of the notice to proceed and part of the Contract more fully described in the attached specifications must be completed within _____ days. Upon completion of the work covered by the preceding sentence, the vendor agrees that maintenance, monitoring, or warranty services will be provided for _____ year(s) thereafter.

One Time Purchase: The term of this Contract shall run from the issuance of the Award Document until all of the goods contracted for have been delivered, but in no event will this Contract extend for more than one fiscal year.

Other: See attached.

4. NOTICE TO PROCEED: Vendor shall begin performance of this Contract immediately upon receiving notice to proceed unless otherwise instructed by the Agency. Unless otherwise specified, the fully executed Award Document will be considered notice to proceed.

5. QUANTITIES: The quantities required under this Contract shall be determined in accordance with the category that has been identified as applicable to this Contract below.

Open End Contract: Quantities listed in this Solicitation are approximations only, based on estimates supplied by the Agency. It is understood and agreed that the Contract shall cover the quantities actually ordered for delivery during the term of the Contract, whether more or less than the quantities shown.

Service: The scope of the service to be provided will be more clearly defined in the specifications included herewith.

Combined Service and Goods: The scope of the service and deliverable goods to be provided will be more clearly defined in the specifications included herewith.

One Time Purchase: This Contract is for the purchase of a set quantity of goods that are identified in the specifications included herewith. Once those items have been delivered, no additional goods may be procured under this Contract without an appropriate change order approved by the Vendor, Agency, Purchasing Division, and Attorney General's office.

6. EMERGENCY PURCHASES: The Purchasing Division Director may authorize the Agency to purchase goods or services in the open market that Vendor would otherwise provide under this Contract if those goods or services are for immediate or expedited delivery in an emergency. Emergencies shall include, but are not limited to, delays in transportation or an unanticipated increase in the volume of work. An emergency purchase in the open market, approved by the Purchasing Division Director, shall not constitute a breach of this Contract and shall not entitle the Vendor to any form of compensation or damages. This provision does not excuse the State from fulfilling its obligations under a One Time Purchase contract.

7. REQUIRED DOCUMENTS: All of the items checked below must be provided to the Purchasing Division by the Vendor as specified below.

BID BOND (Construction Only): Pursuant to the requirements contained in W. Va. Code § 5-22-1(c), All Vendors submitting a bid on a construction project shall furnish a valid bid bond in the amount of five percent (5%) of the total amount of the bid protecting the State of West Virginia. The bid bond must be submitted with the bid.

PERFORMANCE BOND: The apparent successful Vendor shall provide a performance bond in the amount of 100% of the contract. The performance bond must be received by the Purchasing Division prior to Contract award.

LABOR/MATERIAL PAYMENT BOND: The apparent successful Vendor shall provide a labor/material payment bond in the amount of 100% of the Contract value. The labor/material payment bond must be delivered to the Purchasing Division prior to Contract award.

In lieu of the Bid Bond, Performance Bond, and Labor/Material Payment Bond, the Vendor may provide certified checks, cashier's checks, or irrevocable letters of credit. Any certified check, cashier's check, or irrevocable letter of credit provided in lieu of a bond must be of the same amount and delivered on the same schedule as the bond it replaces. A letter of credit submitted in lieu of a performance and labor/material payment bond will only be allowed for projects under \$100,000. Personal or business checks are not acceptable. Notwithstanding the foregoing, West Virginia Code § 5-22-1 (d) mandates that a vendor provide a performance and labor/material payment bond for construction projects. Accordingly, substitutions for the performance and labor/material payment bonds for construction projects is not permitted.

MAINTENANCE BOND: The apparent successful Vendor shall provide a two (2) year maintenance bond covering the roofing system. The maintenance bond must be issued and delivered to the Purchasing Division prior to Contract award.

LICENSE(S) / CERTIFICATIONS / PERMITS: In addition to anything required under the Section of the General Terms and Conditions entitled Licensing, the apparent successful Vendor shall furnish proof of the following licenses, certifications, and/or permits upon request and in a form acceptable to the State. The request may be prior to or after contract award at the State's sole discretion.

The apparent successful Vendor shall also furnish proof of any additional licenses or certifications contained in the specifications regardless of whether or not that requirement is listed above.

8. INSURANCE: The apparent successful Vendor shall furnish proof of the insurance identified by a checkmark below and must include the State as an additional insured on each policy prior to Contract award. The insurance coverages identified below must be maintained throughout the life of this contract. Thirty (30) days prior to the expiration of the insurance policies, Vendor shall provide the Agency with proof that the insurance mandated herein has been continued. Vendor must also provide Agency with immediate notice of any changes in its insurance policies, including but not limited to, policy cancelation, policy reduction, or change in insurers. The apparent successful Vendor shall also furnish proof of any additional insurance requirements contained in the specifications prior to Contract award regardless of whether or not that insurance requirement is listed in this section.

Vendor must maintain:

- Commercial General Liability Insurance** in at least an amount of: \$1,000,000.00 per occurrence.
- Automobile Liability Insurance** in at least an amount of: \$1,000,000.00 per occurrence.
- Professional/Malpractice/Errors and Omission Insurance** in at least an amount of: _____ per occurrence. Notwithstanding the forgoing, Vendor's are not required to list the State as an additional insured for this type of policy.
- Commercial Crime and Third Party Fidelity Insurance** in an amount of: _____ per occurrence.
- Cyber Liability Insurance** in an amount of: _____ per occurrence.
- Builders Risk Insurance** in an amount equal to 100% of the amount of the Contract.
- Pollution Insurance** in an amount of: _____ per occurrence.
- Aircraft Liability** in an amount of: _____ per occurrence.
-
-
-
-

Notwithstanding anything contained in this section to the contrary, the Director of the Purchasing Division reserves the right to waive the requirement that the State be named as an additional insured on one or more of the Vendor's insurance policies if the Director finds that doing so is in the State's best interest.

9. WORKERS' COMPENSATION INSURANCE: The apparent successful Vendor shall comply with laws relating to workers compensation, shall maintain workers' compensation insurance when required, and shall furnish proof of workers' compensation insurance upon request.

10. [Reserved]

11. LIQUIDATED DAMAGES: This clause shall in no way be considered exclusive and shall not limit the State or Agency's right to pursue any other available remedy. Vendor shall pay liquidated damages in the amount specified below or as described in the specifications:

_____ for _____

Liquidated Damages Contained in the Specifications

12. ACCEPTANCE: Vendor's signature on its bid, or on the certification and signature page, constitutes an offer to the State that cannot be unilaterally withdrawn, signifies that the product or service proposed by vendor meets the mandatory requirements contained in the Solicitation for that product or service, unless otherwise indicated, and signifies acceptance of the terms and conditions contained in the Solicitation unless otherwise indicated.

13. PRICING: The pricing set forth herein is firm for the life of the Contract, unless specified elsewhere within this Solicitation/Contract by the State. A Vendor's inclusion of price adjustment provisions in its bid, without an express authorization from the State in the Solicitation to do so, may result in bid disqualification. Notwithstanding the foregoing, Vendor must extend any publicly advertised sale price to the State and invoice at the lower of the contract price or the publicly advertised sale price.

14. PAYMENT IN ARREARS: Payment in advance is prohibited under this Contract. Payment may only be made after the delivery and acceptance of goods or services. The Vendor shall submit invoices, in arrears.

15. PAYMENT METHODS: Vendor must accept payment by electronic funds transfer and P-Card. (The State of West Virginia's Purchasing Card program, administered under contract by a banking institution, processes payment for goods and services through state designated credit cards.)

16. TAXES: The Vendor shall pay any applicable sales, use, personal property or any other taxes arising out of this Contract and the transactions contemplated thereby. The State of West Virginia is exempt from federal and state taxes and will not pay or reimburse such taxes.

17. ADDITIONAL FEES: Vendor is not permitted to charge additional fees or assess additional charges that were not either expressly provided for in the solicitation published by the State of West Virginia or included in the unit price or lump sum bid amount that Vendor is required by the solicitation to provide. Including such fees or charges as notes to the solicitation may result in rejection of vendor's bid. Requesting such fees or charges be paid after the contract has been awarded may result in cancellation of the contract.

18. FUNDING: This Contract shall continue for the term stated herein, contingent upon funds being appropriated by the Legislature or otherwise being made available. In the event funds are not appropriated or otherwise made available, this Contract becomes void and of no effect beginning on July 1 of the fiscal year for which funding has not been appropriated or otherwise made available.

19. CANCELLATION: The Purchasing Division Director reserves the right to cancel this Contract immediately upon written notice to the vendor if the materials or workmanship supplied do not conform to the specifications contained in the Contract. The Purchasing Division Director may also cancel any purchase or Contract upon 30 days written notice to the Vendor in accordance with West Virginia Code of State Rules § 148-1-5.2.b.

20. TIME: Time is of the essence with regard to all matters of time and performance in this Contract.

21. APPLICABLE LAW: This Contract is governed by and interpreted under West Virginia law without giving effect to its choice of law principles. Any information provided in specification manuals, or any other source, verbal or written, which contradicts or violates the West Virginia Constitution, West Virginia Code or West Virginia Code of State Rules is void and of no effect.

22. COMPLIANCE WITH LAWS: Vendor shall comply with all applicable federal, state, and local laws, regulations and ordinances. By submitting a bid, Vendor acknowledges that it has reviewed, understands, and will comply with all applicable laws, regulations, and ordinances.

SUBCONTRACTOR COMPLIANCE: Vendor shall notify all subcontractors providing commodities or services related to this Contract that as subcontractors, they too are required to comply with all applicable laws, regulations, and ordinances. Notification under this provision must occur prior to the performance of any work under the contract by the subcontractor.

23. ARBITRATION: Any references made to arbitration contained in this Contract, Vendor's bid, or in any American Institute of Architects documents pertaining to this Contract are hereby deleted, void, and of no effect.

24. MODIFICATIONS: This writing is the parties' final expression of intent. Notwithstanding anything contained in this Contract to the contrary no modification of this Contract shall be binding without mutual written consent of the Agency, and the Vendor, with approval of the Purchasing Division and the Attorney General's office (Attorney General approval is as to form only). Any change to existing contracts that adds work or changes contract cost, and were not included in the original contract, must be approved by the Purchasing Division and the Attorney General's Office (as to form) prior to the implementation of the change or commencement of work affected by the change.

25. WAIVER: The failure of either party to insist upon a strict performance of any of the terms or provision of this Contract, or to exercise any option, right, or remedy herein contained, shall not be construed as a waiver or a relinquishment for the future of such term, provision, option, right, or remedy, but the same shall continue in full force and effect. Any waiver must be expressly stated in writing and signed by the waiving party.

26. SUBSEQUENT FORMS: The terms and conditions contained in this Contract shall supersede any and all subsequent terms and conditions which may appear on any form documents submitted by Vendor to the Agency or Purchasing Division such as price lists, order forms, invoices, sales agreements, or maintenance agreements, and includes internet websites or other electronic documents. Acceptance or use of Vendor's forms does not constitute acceptance of the terms and conditions contained thereon.

27. ASSIGNMENT: Neither this Contract nor any monies due, or to become due hereunder, may be assigned by the Vendor without the express written consent of the Agency, the Purchasing Division, the Attorney General's office (as to form only), and any other government agency or office that may be required to approve such assignments.

28. WARRANTY: The Vendor expressly warrants that the goods and/or services covered by this Contract will: (a) conform to the specifications, drawings, samples, or other description furnished or specified by the Agency; (b) be merchantable and fit for the purpose intended; and (c) be free from defect in material and workmanship.

29. STATE EMPLOYEES: State employees are not permitted to utilize this Contract for personal use and the Vendor is prohibited from permitting or facilitating the same.

30. PRIVACY, SECURITY, AND CONFIDENTIALITY: The Vendor agrees that it will not disclose to anyone, directly or indirectly, any such personally identifiable information or other confidential information gained from the Agency, unless the individual who is the subject of the information consents to the disclosure in writing or the disclosure is made pursuant to the Agency's policies, procedures, and rules. Vendor further agrees to comply with the Confidentiality Policies and Information Security Accountability Requirements, set forth in <http://www.state.wv.us/admin/purchase/privacy/default.html>.

31. YOUR SUBMISSION IS A PUBLIC DOCUMENT: Vendor's entire response to the Solicitation and the resulting Contract are public documents. As public documents, they will be disclosed to the public following the bid/proposal opening or award of the contract, as required by the competitive bidding laws of West Virginia Code §§ 5A-3-1 et seq., 5-22-1 et seq., and 5G-1-1 et seq. and the Freedom of Information Act West Virginia Code §§ 29B-1-1 et seq.

DO NOT SUBMIT MATERIAL YOU CONSIDER TO BE CONFIDENTIAL, A TRADE SECRET, OR OTHERWISE NOT SUBJECT TO PUBLIC DISCLOSURE.

Submission of any bid, proposal, or other document to the Purchasing Division constitutes your explicit consent to the subsequent public disclosure of the bid, proposal, or document. The Purchasing Division will disclose any document labeled "confidential," "proprietary," "trade secret," "private," or labeled with any other claim against public disclosure of the documents, to include any "trade secrets" as defined by West Virginia Code § 47-22-1 et seq. All submissions are subject to public disclosure without notice.

32. LICENSING: In accordance with West Virginia Code of State Rules § 148-1-6.1.e, Vendor must be licensed and in good standing in accordance with any and all state and local laws and requirements by any state or local agency of West Virginia, including, but not limited to, the West Virginia Secretary of State's Office, the West Virginia Tax Department, West Virginia Insurance Commission, or any other state agency or political subdivision. Obligations related to political subdivisions may include, but are not limited to, business licensing, business and occupation taxes, inspection compliance, permitting, etc. Upon request, the Vendor must provide all necessary releases to obtain information to enable the Purchasing Division Director or the Agency to verify that the Vendor is licensed and in good standing with the above entities.

SUBCONTRACTOR COMPLIANCE: Vendor shall notify all subcontractors providing commodities or services related to this Contract that as subcontractors, they too are required to be licensed, in good standing, and up-to-date on all state and local obligations as described in this section. Obligations related to political subdivisions may include, but are not limited to, business licensing, business and occupation taxes, inspection compliance, permitting, etc. Notification under this provision must occur prior to the performance of any work under the contract by the subcontractor.

33. ANTITRUST: In submitting a bid to, signing a contract with, or accepting a Award Document from any agency of the State of West Virginia, the Vendor agrees to convey, sell, assign, or transfer to the State of West Virginia all rights, title, and interest in and to all causes of action it may now or hereafter acquire under the antitrust laws of the United States and the State of West Virginia for price fixing and/or unreasonable restraints of trade relating to the particular commodities or services purchased or acquired by the State of West Virginia. Such assignment shall be made and become effective at the time the purchasing agency tenders the initial payment to Vendor.

34. VENDOR CERTIFICATIONS: By signing its bid or entering into this Contract, Vendor certifies (1) that its bid or offer was made without prior understanding, agreement, or connection with any corporation, firm, limited liability company, partnership, person or entity submitting a bid or offer for the same material, supplies, equipment or services; (2) that its bid or offer is in all respects fair and without collusion or fraud; (3) that this Contract is accepted or entered into without any prior understanding, agreement, or connection to any other entity that could be considered a violation of law; and (4) that it has reviewed this Solicitation in its entirety; understands the requirements, terms and conditions, and other information contained herein.

Vendor's signature on its bid or offer also affirms that neither it nor its representatives have any interest, nor shall acquire any interest, direct or indirect, which would compromise the performance of its services hereunder. Any such interests shall be promptly presented in detail to the Agency. The individual signing this bid or offer on behalf of Vendor certifies that he or she is authorized by the Vendor to execute this bid or offer or any documents related thereto on Vendor's behalf; that he or she is authorized to bind the Vendor in a contractual relationship; and that, to the best of his or her knowledge, the Vendor has properly registered with any State agency that may require registration.

35. VENDOR RELATIONSHIP: The relationship of the Vendor to the State shall be that of an independent contractor and no principal-agent relationship or employer-employee relationship is contemplated or created by this Contract. The Vendor as an independent contractor is solely liable for the acts and omissions of its employees and agents. Vendor shall be responsible for selecting, supervising, and compensating any and all individuals employed pursuant to the terms of this Solicitation and resulting contract. Neither the Vendor, nor any employees or subcontractors of the Vendor, shall be deemed to be employees of the State for any purpose whatsoever. Vendor shall be exclusively responsible for payment of employees and contractors for all wages and salaries, taxes, withholding payments, penalties, fees, fringe benefits, professional liability insurance premiums, contributions to insurance and pension, or other deferred compensation plans, including but not limited to, Workers' Compensation and Social Security obligations, licensing fees, etc. and the filing of all necessary documents, forms, and returns pertinent to all of the foregoing.

Vendor shall hold harmless the State, and shall provide the State and Agency with a defense against any and all claims including, but not limited to, the foregoing payments, withholdings, contributions, taxes, Social Security taxes, and employer income tax returns.

36. INDEMNIFICATION: The Vendor agrees to indemnify, defend, and hold harmless the State and the Agency, their officers, and employees from and against: (1) Any claims or losses for services rendered by any subcontractor, person, or firm performing or supplying services, materials, or supplies in connection with the performance of the Contract; (2) Any claims or losses resulting to any person or entity injured or damaged by the Vendor, its officers, employees, or subcontractors by the publication, translation, reproduction, delivery, performance, use, or disposition of any data used under the Contract in a manner not authorized by the Contract, or by Federal or State statutes or regulations; and (3) Any failure of the Vendor, its officers, employees, or subcontractors to observe State and Federal laws including, but not limited to, labor and wage and hour laws.

37. PURCHASING AFFIDAVIT: In accordance with West Virginia Code §§ 5A-3-10a and 5-22-1(i), the State is prohibited from awarding a contract to any bidder that owes a debt to the State or a political subdivision of the State, Vendors are required to sign, notarize, and submit the Purchasing Affidavit to the Purchasing Division affirming under oath that it is not in default on any monetary obligation owed to the state or a political subdivision of the state.

38. ADDITIONAL AGENCY AND LOCAL GOVERNMENT USE: This Contract may be utilized by other agencies, spending units, and political subdivisions of the State of West Virginia; county, municipal, and other local government bodies; and school districts ("Other Government Entities"), provided that both the Other Government Entity and the Vendor agree. Any extension of this Contract to the aforementioned Other Government Entities must be on the same prices, terms, and conditions as those offered and agreed to in this Contract, provided that such extension is in compliance with the applicable laws, rules, and ordinances of the Other Government Entity. A refusal to extend this Contract to the Other Government Entities shall not impact or influence the award of this Contract in any manner.

39. CONFLICT OF INTEREST: Vendor, its officers or members or employees, shall not presently have or acquire an interest, direct or indirect, which would conflict with or compromise the performance of its obligations hereunder. Vendor shall periodically inquire of its officers, members and employees to ensure that a conflict of interest does not arise. Any conflict of interest discovered shall be promptly presented in detail to the Agency.

40. REPORTS: Vendor shall provide the Agency and/or the Purchasing Division with the following reports identified by a checked box below:

Such reports as the Agency and/or the Purchasing Division may request. Requested reports may include, but are not limited to, quantities purchased, agencies utilizing the contract, total contract expenditures by agency, etc.

Quarterly reports detailing the total quantity of purchases in units and dollars, along with a listing of purchases by agency. Quarterly reports should be delivered to the Purchasing Division via email at purchasing.requisitions@wv.gov.

41. BACKGROUND CHECK: In accordance with W. Va. Code § 15-2D-3, the Director of the Division of Protective Services shall require any service provider whose employees are regularly employed on the grounds or in the buildings of the Capitol complex or who have access to sensitive or critical information to submit to a fingerprint-based state and federal background inquiry through the state repository. The service provider is responsible for any costs associated with the fingerprint-based state and federal background inquiry.

After the contract for such services has been approved, but before any such employees are permitted to be on the grounds or in the buildings of the Capitol complex or have access to sensitive or critical information, the service provider shall submit a list of all persons who will be physically present and working at the Capitol complex to the Director of the Division of Protective Services for purposes of verifying compliance with this provision. The State reserves the right to prohibit a service provider's employees from accessing sensitive or critical information or to be present at the Capitol complex based upon results addressed from a criminal background check.

Revised 01/09/2020

Service providers should contact the West Virginia Division of Protective Services by phone at (304) 558-9911 for more information.

42. PREFERENCE FOR USE OF DOMESTIC STEEL PRODUCTS: Except when authorized by the Director of the Purchasing Division pursuant to W. Va. Code § 5A-3-56, no contractor may use or supply steel products for a State Contract Project other than those steel products made in the United States. A contractor who uses steel products in violation of this section may be subject to civil penalties pursuant to W. Va. Code § 5A-3-56. As used in this section:

- a. "State Contract Project" means any erection or construction of, or any addition to, alteration of or other improvement to any building or structure, including, but not limited to, roads or highways, or the installation of any heating or cooling or ventilating plants or other equipment, or the supply of and materials for such projects, pursuant to a contract with the State of West Virginia for which bids were solicited on or after June 6, 2001.
- b. "Steel Products" means products rolled, formed, shaped, drawn, extruded, forged, cast, fabricated or otherwise similarly processed, or processed by a combination of two or more or such operations, from steel made by the open heath, basic oxygen, electric furnace, Bessemer or other steel making process. The Purchasing Division Director may, in writing, authorize the use of foreign steel products if:
- c. The cost for each contract item used does not exceed one tenth of one percent (.1%) of the total contract cost or two thousand five hundred dollars (\$2,500.00), whichever is greater. For the purposes of this section, the cost is the value of the steel product as delivered to the project; or
- d. The Director of the Purchasing Division determines that specified steel materials are not produced in the United States in sufficient quantity or otherwise are not reasonably available to meet contract requirements.

43. PREFERENCE FOR USE OF DOMESTIC ALUMINUM, GLASS, AND STEEL: In Accordance with W. Va. Code § 5-19-1 et seq., and W. Va. CSR § 148-10-1 et seq., for every contract or subcontract, subject to the limitations contained herein, for the construction, reconstruction, alteration, repair, improvement or maintenance of public works or for the purchase of any item of machinery or equipment to be used at sites of public works, only domestic aluminum, glass or steel products shall be supplied unless the spending officer determines, in writing, after the receipt of offers or bids, (1) that the cost of domestic aluminum, glass or steel products is unreasonable or inconsistent with the public interest of the State of West Virginia, (2) that domestic aluminum, glass or steel products are not produced in sufficient quantities to meet the contract requirements, or (3) the available domestic aluminum, glass, or steel do not meet the contract specifications. This provision only applies to public works contracts awarded in an amount more than fifty thousand dollars (\$50,000) or public works contracts that require more than ten thousand pounds of steel products.

The cost of domestic aluminum, glass, or steel products may be unreasonable if the cost is more than twenty percent (20%) of the bid or offered price for foreign made aluminum, glass, or steel products. If the domestic aluminum, glass or steel products to be supplied or produced in a

“substantial labor surplus area”, as defined by the United States Department of Labor, the cost of domestic aluminum, glass, or steel products may be unreasonable if the cost is more than thirty percent (30%) of the bid or offered price for foreign made aluminum, glass, or steel products. This preference shall be applied to an item of machinery or equipment, as indicated above, when the item is a single unit of equipment or machinery manufactured primarily of aluminum, glass or steel, is part of a public works contract and has the sole purpose or of being a permanent part of a single public works project. This provision does not apply to equipment or machinery purchased by a spending unit for use by that spending unit and not as part of a single public works project.

All bids and offers including domestic aluminum, glass or steel products that exceed bid or offer prices including foreign aluminum, glass or steel products after application of the preferences provided in this provision may be reduced to a price equal to or lower than the lowest bid or offer price for foreign aluminum, glass or steel products plus the applicable preference. If the reduced bid or offer prices are made in writing and supersede the prior bid or offer prices, all bids or offers, including the reduced bid or offer prices, will be reevaluated in accordance with this rule.

44. INTERESTED PARTY SUPPLEMENTAL DISCLOSURE: W. Va. Code § 6D-1-2 requires that for contracts with an actual or estimated value of at least \$1 million, the vendor must submit to the Agency a supplemental disclosure of interested parties reflecting any new or differing interested parties to the contract, which were not included in the original pre-award interested party disclosure, within 30 days following the completion or termination of the contract. A copy of that form is included with this solicitation or can be obtained from the WV Ethics Commission. This requirement does not apply to publicly traded companies listed on a national or international stock exchange. A more detailed definition of interested parties can be obtained from the form referenced above.

45. PROHIBITION AGAINST USED OR REFURBISHED: Unless expressly permitted in the solicitation published by the State, Vendor must provide new, unused commodities, and is prohibited from supplying used or refurbished commodities, in fulfilling its responsibilities under this Contract.

DESIGNATED CONTACT: Vendor appoints the individual identified in this Section as the Contract Administrator and the initial point of contact for matters relating to this Contract.

Paul Daniels, Sales
(Name, Title)
Paul Daniels, Sales
(Printed Name and Title)
19 Gott Crossing Drive Cross Lanes, WV 25313
(Address)
304-204-1818 304-204-1811
(Phone Number) / (Fax Number)
daniels.paul@lec1.com
(email address)

CERTIFICATION AND SIGNATURE: By signing below, or submitting documentation through wvOASIS, I certify that I have reviewed this Solicitation in its entirety; that I understand the requirements, terms and conditions, and other information contained herein; that this bid, offer or proposal constitutes an offer to the State that cannot be unilaterally withdrawn; that the product or service proposed meets the mandatory requirements contained in the Solicitation for that product or service, unless otherwise stated herein; that the Vendor accepts the terms and conditions contained in the Solicitation, unless otherwise stated herein; that I am submitting this bid, offer or proposal for review and consideration; that I am authorized by the vendor to execute and submit this bid, offer, or proposal, or any documents related thereto on vendor's behalf; that I am authorized to bind the vendor in a contractual relationship; and that to the best of my knowledge, the vendor has properly registered with any State agency that may require registration.

Lestic Equipment Co.
(Company)
Paul Daniels - Sales
(Authorized Signature) (Representative Name, Title)
Paul Daniels - Sales
(Printed Name and Title of Authorized Representative)
2-24-2021
(Date)
304-204-1818 304-204-1811
(Phone Number) (Fax Number)

**ADDENDUM ACKNOWLEDGEMENT FORM
SOLICITATION NO.:**

Instructions: Please acknowledge receipt of all addenda issued with this solicitation by completing this addendum acknowledgment form. Check the box next to each addendum received and sign below. Failure to acknowledge addenda may result in bid disqualification.

Acknowledgment: I hereby acknowledge receipt of the following addenda and have made the necessary revisions to my proposal, plans and/or specification, etc.

Addendum Numbers Received:

(Check the box next to each addendum received)

- | | |
|--|--|
| <input checked="" type="checkbox"/> Addendum No. 1 | <input type="checkbox"/> Addendum No. 6 |
| <input type="checkbox"/> Addendum No. 2 | <input type="checkbox"/> Addendum No. 7 |
| <input type="checkbox"/> Addendum No. 3 | <input type="checkbox"/> Addendum No. 8 |
| <input type="checkbox"/> Addendum No. 4 | <input type="checkbox"/> Addendum No. 9 |
| <input type="checkbox"/> Addendum No. 5 | <input type="checkbox"/> Addendum No. 10 |

I understand that failure to confirm the receipt of addenda may be cause for rejection of this bid. I further understand that any verbal representation made or assumed to be made during any oral discussion held between Vendor's representatives and any state personnel is not binding. Only the information issued in writing and added to the specifications by an official addendum is binding.

Leslie Equipment Co.
Company

Paul Daniels
Authorized Signature

2-24-2021
Date

NOTE: This addendum acknowledgement should be submitted with the bid to expedite document processing.

REQUEST FOR QUOTATION
HYDRAULIC COMPACT TRACK LOADER
With Grapple Bucket

SPECIFICATIONS

1. **PURPOSE AND SCOPE:** The West Virginia Purchasing Division is soliciting bids on behalf of the West Virginia Department of Environmental Protection (WVDEP), Rehabilitation Environmental Action Plan (REAP), to establish a one-time purchase of one (1) Compact Track Loader or Equal and the associated listed attachments.

2. **DEFINITIONS:** The terms listed below shall have the meanings assigned to them below. Additional definitions can be found in section 2 of the General Terms and Conditions.
 - 2.1 “**Contract Item**” or “**Contract Items**” means the list of items identified in Section 3, Subsection 1 below.
 - 2.2 “**Pricing Pages**” means the schedule of prices, estimated order quantity, and totals contained in wvOASIS or attached hereto as Exhibit A and used to evaluate the solicitation responses.
 - 2.3 “**Solicitation**” means the official notice of an opportunity to supply the State with goods or services that is published by the Purchasing Division.
 - 2.4 “**WVDEP**” means West Virginia Department of Environmental Protection.
 - 2.5 “**GPM**” means gallons per minute.
 - 2.6 “**ROPS**” means roll over protection structure.
 - 2.7 “**FLOPS**” means falling object protection structure.
 - 2.8 “**OEM**” means original equipment of manufacture.

3. **GENERAL REQUIREMENTS:**
 - 3.1 **Contract Items and Mandatory Requirements:** Unit bid shall be an ASV VT-70 High Output or Equal. Contract Items must meet or exceed the mandatory requirements as shown below.
 - 3.1.1 **Compact Track Loader with Construction Grapple Bucket**
 - 3.1.1.1 Unit shall have vertical lift loader arms.
 - 3.1.1.2 Unit shall have a minimum operating weight of 8,000 pounds and a maximum operating weight of 8,500 pounds including grapple bucket.

REQUEST FOR QUOTATION
HYDRAULIC COMPACT TRACK LOADER
With Grapple Bucket

3.1.1.3 The unit specified herein and offered shall be manufactured on or after January 1, 2020 and will be clearly identified and marked with date of manufacture.

3.1.2 Engine:

3.1.2.1 Engine shall be a minimum of 74 horsepower; diesel engine, liquid cooled.

3.1.2.2 Engine shall include the following characteristics.

3.1.2.2.1 Fuel water separator filter factory installed.

3.1.2.2.2 12-volt system.

3.1.2.2.3 Electric fuel priming pump.

3.1.3 Powertrain:

3.1.3.1 Unit shall have minimum of one (1) high and a minimum of one (1) low travel speed.

3.1.4 Hydraulic System:

3.1.4.1 Unit shall have hydraulic system that will accept different attachments and maintain safe oil temperature within manufacturers recommended operation range during continuous operation under maximum working combinations.

3.1.4.2 Unit shall be equipped with a factory installed grapple bucket.

3.1.4.3 Drive shall be hydrostatic design with single joystick control.

3.1.4.4 Unit shall be joystick controlled with a minimum of one (1) additional actuator for auxiliary hydraulics.

3.1.4.5 Unit shall have auxiliary hydraulic valve section.

REQUEST FOR QUOTATION
HYDRAULIC COMPACT TRACK LOADER
With Grapple Bucket

3.1.4.6 Unit shall have auxiliary hydraulic lines with quick couplers.

3.1.4.7 Unit shall have auxiliary work tool flow control adjustment capabilities.

3.1.4.8 Unit shall have high flow auxiliary hydraulic capabilities of no less than 27 GPM.

3.1.5 Undercarriage:

3.1.5.1 Undercarriage frame shall be manufacturers standard for model bid and shall include:

3.1.5.1.1 Suspension must consist of two (2) independent torsion axles per undercarriage.

3.1.5.1.2 Must have rubber tracks, minimum of 15 inches wide.

3.1.5.1.3 Must have track guides to prevent track misalignment.

3.1.5.1.4 Must have belly pan guard.

3.1.5.1.5 Must have a minimum track length on ground of 59 inches.

3.1.6 Cab:

3.1.6.1 Cab shall be all weather steel with ROPS/FLOPS with all around visibility.

3.1.6.2 Cab shall have a suspension seat with padded lap bar.

3.1.6.3 Cab shall be equipped with manufacturers' heater and air conditioning system.

3.1.6.4 Cab shall be equipped with front windshield wiper and washer.

3.1.6.5 Cab shall include manufacturer's vandalism protection package. The vandalism protection package shall include locking operator compartment and locking enclosure for engine. All locks and ignition switch shall be keyed alike.

3.1.6.6 The following shall be included for cab area:

3.1.6.6.1 Interior cab light.

3.1.6.6.2 Four work lights, two (2) positioned forward and two (2) positioned rearward.

REQUEST FOR QUOTATION
HYDRAULIC COMPACT TRACK LOADER

With Grapple Bucket

4.2.1 Vendor's who wish to respond to a Centralized Request for Quotation (CRFQ) online may submit information through the State's wvOASIS Vendor Self Service (VSS).

Vendors should download the Exhibit "A": Pricing Page that is attached separately to the CRFQ and published to the VSS.

- **Vendor must identify Brand, Model and Year equipment being bid and include it with their submitted bid response.**

Any product brochures to support vendor's product should be submitted with vendor's bid response. These brochures and any supporting documentation may be required before award of contract.

5. PAYMENT:

5.1 Payment: Vendor shall accept payment in accordance with the payment procedures of the State of West Virginia.

6. DELIVERY AND RETURN:

6.1 Shipment and Delivery: Vendor shall ship the Contract Items immediately after being awarded this Contract and receiving a purchase order or notice to proceed.

Vendor shall deliver the Contract Items within thirty (30) working days after receiving a purchase order or notice to proceed. **Awarded Vendor must contact the Agency prior to delivery to schedule. Prior to delivery equipment must be completely serviced in accordance with Manufactures "make ready" preparation and in accordance with these specifications and the manufactures recommendations.**

Contract Items must be delivered to Agency at:

601 57th Street, S.E., Charleston, WV 25304.

6.2 Late Delivery: The Agency placing the order under this Contract must be notified in writing if the shipment of the Contract Items will be delayed for any reason. Any delay in delivery that could cause harm to an Agency will be grounds for cancellation of the Contract, and/or obtaining the Contract Items from a third party.

REQUEST FOR QUOTATION
HYDRAULIC COMPACT TRACK LOADER
With Grapple Bucket

7.2.2 Immediate cancellation of one or more release orders issued under this Contract.

7.2.3 Any other remedies available in law or equity.

8 MISCELLANEOUS:

8.1 No Substitutions: Vendor shall supply only Contract Items submitted in response to the Solicitation unless a contract modification is approved in accordance with the provisions contained in this Contract.

8.2 Vendor Supply: Vendor must carry sufficient inventory of the Contract Items being offered to fulfill its obligations under this Contract. By signing its bid, Vendor certifies that it can supply the Contract Items contained in its bid response.

8.3 Reports: Vendor shall provide quarterly reports and annual summaries to the Agency showing the Agency's items purchased, quantities of items purchased, and total dollar value of the items purchased upon request. Vendor shall also provide reports, upon request, showing the items purchased during the term of this Contract, the quantity purchased for each of those items, and the total value of purchases for each of those items. Failure to supply such reports may be grounds for cancellation of this Contract.

8.4 Contract Manager: During its performance of this Contract, Vendor must designate and maintain a primary contract manager responsible for overseeing Vendor's responsibilities under this Contract. The Contract manager must be available during normal business hours to address any customer service or other issues related to this Contract. Vendor should list its Contract manager and his or her contact information below.

Contract Manager: Paul Daniels

Telephone Number: 304-204-1818

Fax Number: 304-204-1811

Email Address: danielspaul@lec1.com

Exhibit A - Pricing Page
West Virginia Department of Environmental Protection (WVDEP), REAP Section
Compact Track Loader w/Attachments

Item No.	Description	Year, Make, and Model	Quantity	Unit Price	Extended Price
3.1.1	Compact Track Loader w/Attachments	2021 John Deere 3256	1	\$57,350. ⁰⁰	\$57,350. ⁰⁰ -
TOTAL BID AMOUNT:					\$57,350. ⁰⁰

Vendor must identify Make and Model at time of submitting Bid Response and should provide Product Brochures.

STATE OF WEST VIRGINIA
Purchasing Division

PURCHASING AFFIDAVIT

CONSTRUCTION CONTRACTS: Under W. Va. Code § 5-22-1(i), the contracting public entity shall not award a construction contract to any bidder that is known to be in default on any monetary obligation owed to the state or a political subdivision of the state, including, but not limited to, obligations related to payroll taxes, property taxes, sales and use taxes, fire service fees, or other fines or fees.

ALL CONTRACTS: Under W. Va. Code §5A-3-10a, no contract or renewal of any contract may be awarded by the state or any of its political subdivisions to any vendor or prospective vendor when the vendor or prospective vendor or a related party to the vendor or prospective vendor is a debtor and: (1) the debt owed is an amount greater than one thousand dollars in the aggregate; or (2) the debtor is in employer default.

EXCEPTION: The prohibition listed above does not apply where a vendor has contested any tax administered pursuant to chapter eleven of the W. Va. Code, workers' compensation premium, permit fee or environmental fee or assessment and the matter has not become final or where the vendor has entered into a payment plan or agreement and the vendor is not in default of any of the provisions of such plan or agreement.

DEFINITIONS:

"Debt" means any assessment, premium, penalty, fine, tax or other amount of money owed to the state or any of its political subdivisions because of a judgment, fine, permit violation, license assessment, defaulted workers' compensation premium, penalty or other assessment presently delinquent or due and required to be paid to the state or any of its political subdivisions, including any interest or additional penalties accrued thereon.

"Employer default" means having an outstanding balance or liability to the old fund or to the uninsured employers' fund or being in policy default, as defined in W. Va. Code § 23-2c-2, failure to maintain mandatory workers' compensation coverage, or failure to fully meet its obligations as a workers' compensation self-insured employer. An employer is not in employer default if it has entered into a repayment agreement with the Insurance Commissioner and remains in compliance with the obligations under the repayment agreement.

"Related party" means a party, whether an individual, corporation, partnership, association, limited liability company or any other form or business association or other entity whatsoever, related to any vendor by blood, marriage, ownership or contract through which the party has a relationship of ownership or other interest with the vendor so that the party will actually or by effect receive or control a portion of the benefit, profit or other consideration from performance of a vendor contract with the party receiving an amount that meets or exceeds five percent of the total contract amount.

AFFIRMATION: By signing this form, the vendor's authorized signer affirms and acknowledges under penalty of law for false swearing (W. Va. Code §61-5-3) that: (1) for construction contracts, the vendor is not in default on any monetary obligation owed to the state or a political subdivision of the state, and (2) for all other contracts, that neither vendor nor any related party owe a debt as defined above and that neither vendor nor any related party are in employer default as defined above, unless the debt or employer default is permitted under the exception above.

WITNESS THE FOLLOWING SIGNATURE:

Vendor's Name: Leslie Equipment Co.

Authorized Signature: [Signature] Date: 2-24-2021

State of West Virginia

County of Kanawha, to-wit:

Taken, subscribed, and sworn to before me this 24th day of February, 2021.

My Commission expires October 19, 2024, 2024.

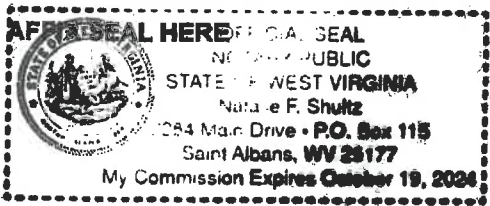

NOTARY PUBLIC [Signature]

REQUEST FOR QUOTATION
HYDRAULIC COMPACT TRACK LOADER
With Grapple Bucket

Any Agency seeking to obtain the Contract Items from a third party under this provision must first obtain approval of the Purchasing Division.

- 6.3 Delivery Payment/Risk of Loss:** Vendor shall deliver the Contract Items F.O.B. destination to the Agency's location.
- 6.4 Return of Unacceptable Items:** If the Agency deems the Contract Items to be unacceptable, the Contract Items shall be returned to Vendor at Vendor's expense and with no restocking charge. Vendor shall either make arrangements for the return within five (5) days of being notified that items are unacceptable or permit the Agency to arrange for the return and reimburse Agency for delivery expenses. If the original packaging cannot be utilized for the return, Vendor will supply the Agency with appropriate return packaging upon request. All returns of unacceptable items shall be F.O.B. the Agency's location. The returned product shall either be replaced, or the Agency shall receive a full credit or refund for the purchase price, at the Agency's discretion.
- 6.5 Return Due to Agency Error:** Items ordered in error by the Agency will be returned for credit within 30 days of receipt, F.O.B. Vendor's location. Vendor shall not charge a restocking fee if returned products are in a resalable condition. Items shall be deemed to be in a resalable condition if they are unused and in the original packaging. Any restocking fee for items not in a resalable condition shall be the lower of the Vendor's customary restocking fee or 5% of the total invoiced value of the returned items.

7 VENDOR DEFAULT:

7.1 The following shall be considered a vendor default under this Contract.

- 7.1.1** Failure to provide Contract Items in accordance with the requirements contained herein.
- 7.1.2** Failure to comply with other specifications and requirements contained herein.
- 7.1.3** Failure to comply with any laws, rules, and ordinances applicable to the Contract Services provided under this Contract.
- 7.1.4** Failure to remedy deficient performance upon request.

7.2 The following remedies shall be available to Agency upon default.

- 7.2.1** Immediate cancellation of the Contract.

REQUEST FOR QUOTATION
HYDRAULIC COMPACT TRACK LOADER

With Grapple Bucket

- 3.1.6.6.3 AM/FM radio with antenna.
- 3.1.6.6.4 Shall have backup alarm.
- 3.1.6.6.5 Horn.
- 3.1.6.6.6 One 12-volt accessory outlet.
- 3.1.6.6.7 Complete engine monitoring system.
- 3.1.6.6.8 Rearview mirror.

3.1.7 Maximum Reach Height

- 3.1.7.1 Unit bid shall have minimum height to bucket pin of 126 inches.

3.1.8 Rated Operating Capacity

- 3.1.8.1 Unit shall have a minimum rated operating capacity (35% of tipping load) of 2300 pounds.

3.1.9 Bucket

- 3.1.9.1 Unit shall include a 66-inch construction/scrap grapple bucket with two (2) individual grapples.

3.1.10 Compact Track Loader Paint:

- 3.1.10.1 Unit shall be painted manufacturers standard color.

4. CONTRACT AWARD:

- 4.1 **Contract Award:** The Contract is intended to provide Agencies with a purchase price for the Contract Items. The Contract shall be awarded to the Vendor that provides the Contract Items meeting the required specifications for the lowest overall total cost as shown on the Pricing Pages.
- 4.2 **Pricing Page:** Vendor should complete the Pricing Page by entering their pricing information in wvOASIS. Vendor should complete the Pricing Page in full as failure to complete the Pricing Page in its entirety may result in Vendor's bid being disqualified.

Vendor should type or electronically enter the information into the Pricing Page to prevent errors in the evaluation.

G-SERIES
**COMPACT TRACK
LOADERS**



JOHN DEERE

325G / 331G / 333G



**INTELLIGENCE
AT WORK**

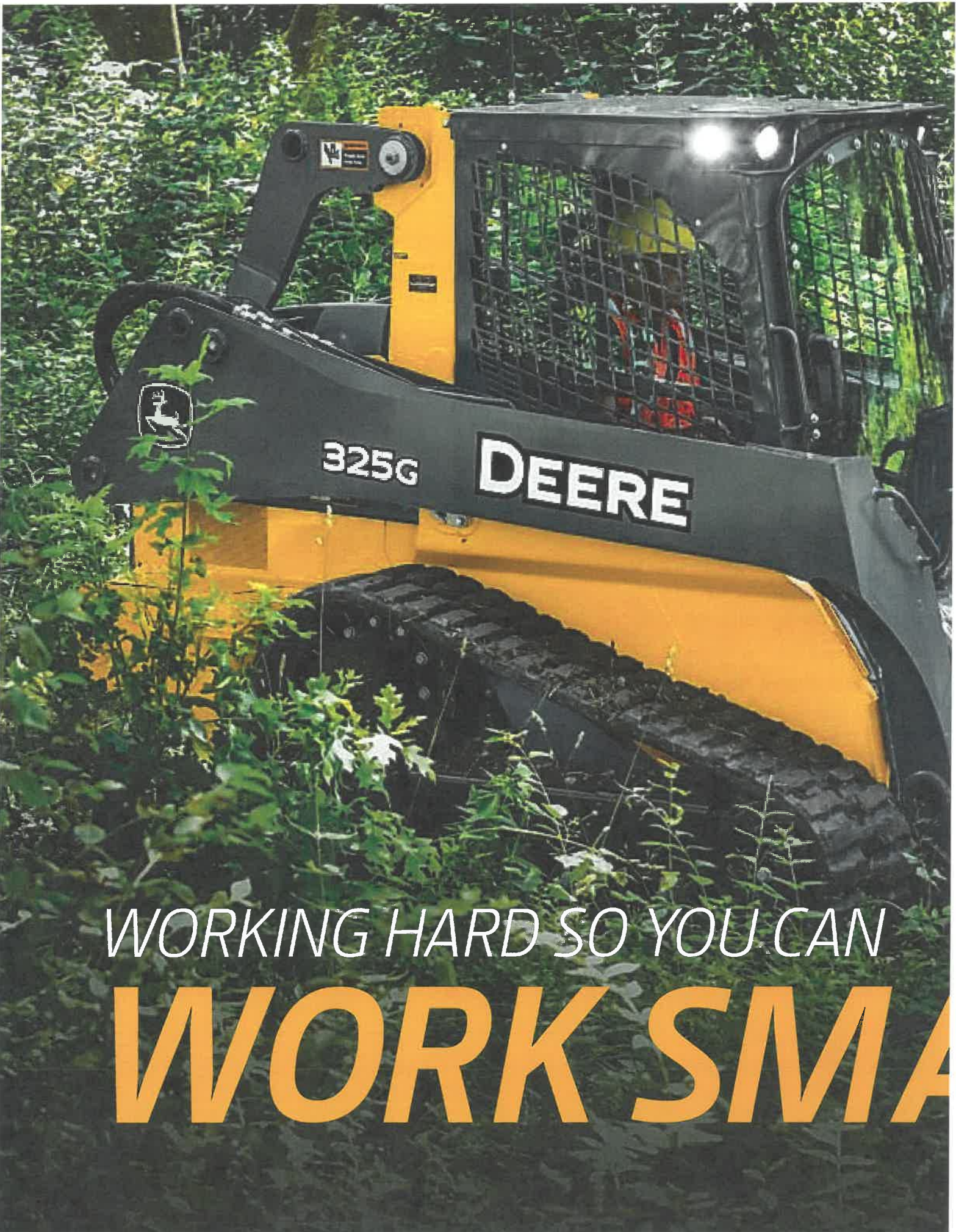

WORKING HARD SO YOU CAN

WORK SMART

THE JOHN DEERE
"G-FORCE"

ART.



RELIABLE

+



PRODUCTIVE



YOUR INSPIRATION, OUR DEDICATION.

You run 'em, so why wouldn't we pick your brain about your expectations of a compact track loader (CTL)? As participants in our Customer Advocate Group, users like you stepped up and helped point the way for the G-Series. Challenged and inspired by your thoughts and ideas, we went to work on Generation Next. We added more power under the hood and increased lift height, dump clearance, reach, stability, and breakout force. And we paid attention to the little things that are a big deal to our customers, like optional heated seat, side lighting, and rearview camera — for more productivity and uptime, at lower daily operating costs.

HEAD-TURNING PERFORMANCE

SEE WHAT YOU CAN DO.

You're going to like what you see in these latest "Gs". They deliver performance that'll really grab your attention — as well as your share of the work.

Beast mode

Extreme pushing power and bucket breakout forces deliver the tractive effort and leverage to carve out clay, power through piles, and handle heavy loads.

Speedsters

Standard on the 331G and 333G (optional on the 325G), two-speed drivetrain delivers travel speeds over eight mph, for quick work cycles.

Fewer pit stops

Fluid-efficient diesels and large tanks enable daylong operation, letting you do more between fill intervals.

Rock-solid stability

Longer track frames and optimized roller spacing on the 331G and 333G improve balance and stability, to enhance agility and operator comfort.

EH boom performance package

Shorten cycle times and speed production in repetitive boom applications with the optional electrohydraulic (EH) boom performance package available on 331G and 333G models.

Hydraulic boost

Increased auxiliary hydraulic flow and power enable G-Series CTLs to make the most of an even broader range of attachments.



2-SPEED DRIVETRAIN

STANDARD ON THE 331G AND 333G,
OPTIONAL ON THE 325G



STANDOUT FEATURE

TALL ORDER.



DO MORE WITH ONE REACH HIGHER WITH LESS EFFORT.

The refined vertical-lift loader design of these compact models rises higher and reaches farther than previous models, for quicker and easier loading. G-Series CTLs serve up substantially greater boom breakout force, so you accomplish more with just one CTL. They also work more comfortably in tight quarters, and they're easy to trailer. Now, who says you can't always get what you want?

Power lifter

Increased rated operating capacities up to 3,700 lb. give these machines the muscle you need to tote heavy loads.

Load warrior

Height to hinge pin up to 11 ft. enables these CTLs to easily load tandem-axle dump trucks, feed mixers, and fill hoppers. You'll also appreciate the additional reach to truck-bed height when handling pallets of pavers or other heavy materials.

Carry more, spill less

Boom design keeps the load close to the machine for better stability. Low center of gravity, up to 35-deg. bucket rollback, and optional ride control and self-leveling also help keep buckets heaped and forks fully loaded.

Dig in

Breakout force has been increased substantially over our previous models, to make lifting heavy loads easier. Helps heap the bucket and keep big loads coming, too.



ROOM WITH A VIEW

EFFICIENT OPERATION THAT'S EASY TO SEE.

Spacious, comfortable cab is tightly sealed to keep out noise and dust. Available options include a four-season cab, Bluetooth® radio, and a heated seat.

Your controls, your way

Choose from four different control styles and performance features:

- Standard equipment: Electrohydraulic (EH) ISO-pattern joystick controls on the 325G, 331G, and 333G
- Optional ISO-H switchable joystick controls and EH joystick performance package*
- Optional EH 4-way switchable controls, including EH foot control, ISO joystick control, H-pattern joystick control, and ISO and foot controls on the 331G and 333G
- Optional ISO controls with programmable detents with the EH joystick performance package* and the EH boom performance package on the 331G and 333G†

**EH joystick performance package features switchable accelerator/decelerator, selectable propel speeds, creep control, boom- and bucket-speed settings, and 12-volt 3- and 14-pin attachment-control harness with dash-mounted 4th-function rocker switch.*

†EH boom performance package features include EH bucket self-level up and down, return to dig, return to carry, and boom-height kick-out.

Four-season comfort

Add a heated air-suspension seat to the heated and air-conditioned pressurized cab to enhance comfort no matter the weather.

Get good grades

Available on the 330G and 332G, optional onboard grade-indication provides a real-time readout of cross-slope (roll of the machine) and mainfall slope (pitch of the machine) on the in-cab monitor:

- Reference **absolute value**, or machine relationship to an absolute flat plane, to easily grade a flat pad.
- Access **relative value**, or machine relationship to the existing grade, to make a steeper existing grade.

Heads-up operation

Easy-to-read LCD monitor provides a wealth of machine info and control – including vital operating conditions and advanced diagnostics.

Lighten up

Excellent all-around visibility has been further enhanced with customer-inspired LED side-lighting and rearview-camera options.

Push-button convenience

Optional sealed-switch module controls amenities such as keyless start and anti-theft settings, plus fingertip activation of numerous machine functions including optional ride control and self-leveling.

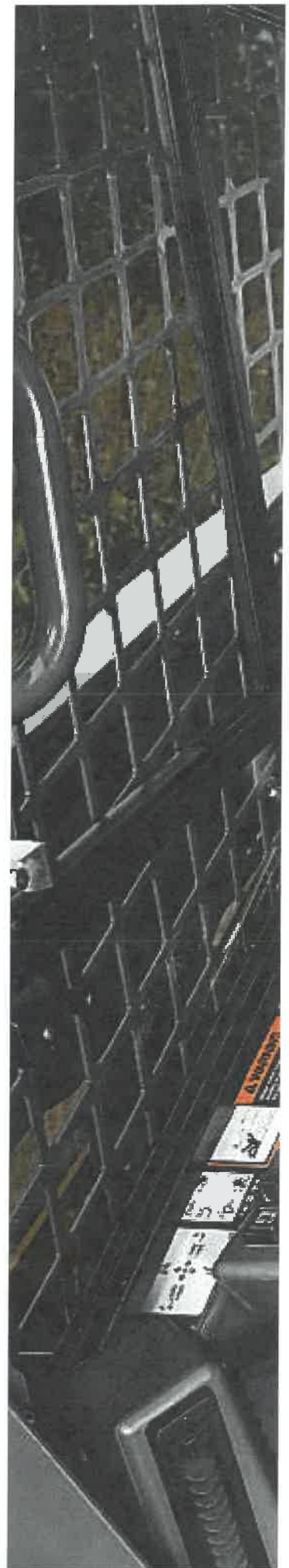
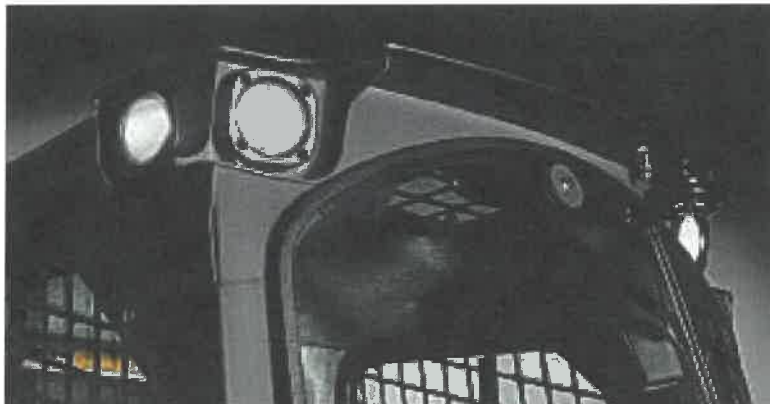

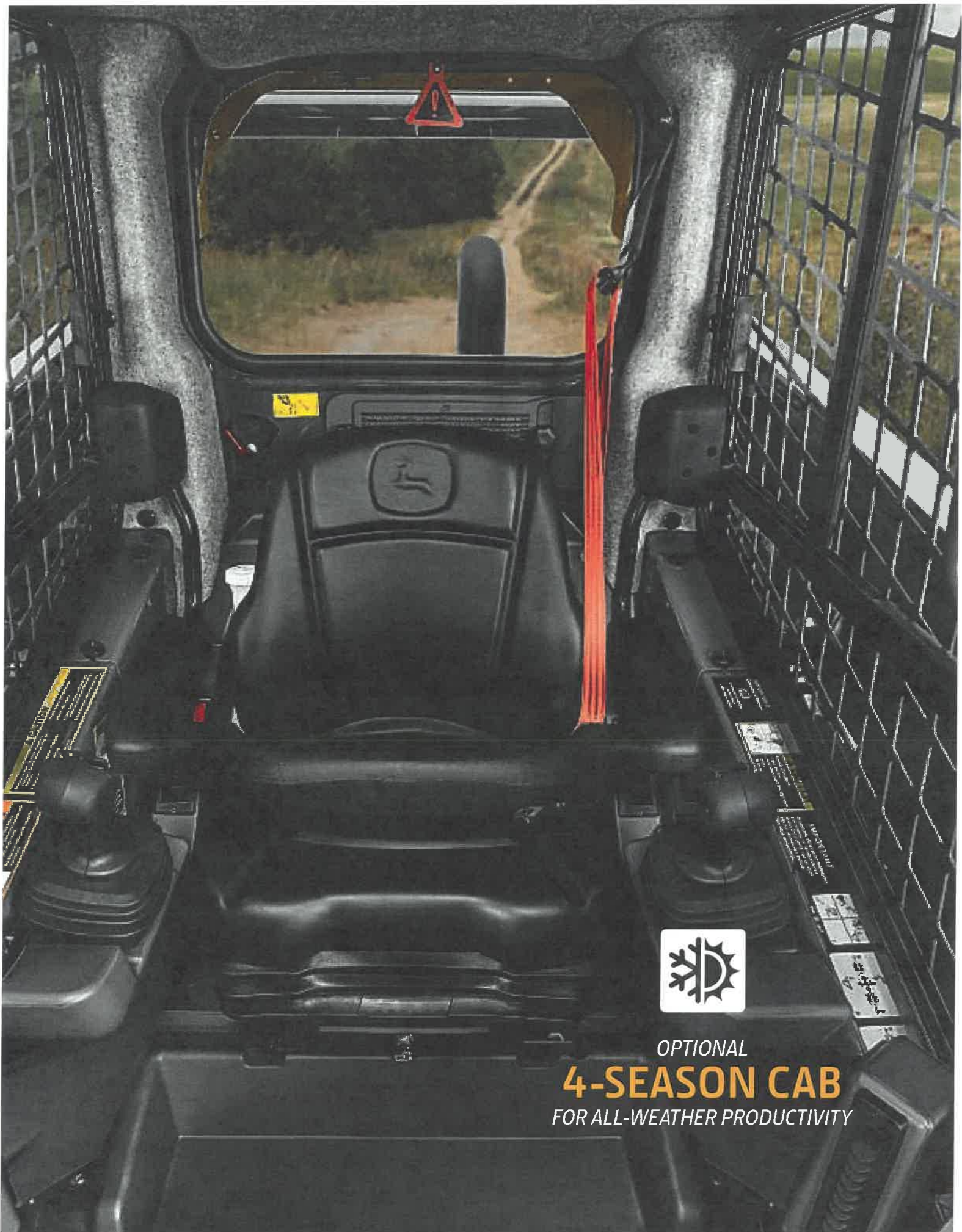

OPTIONAL
4-SEASON CAB
FOR ALL-WEATHER PRODUCTIVITY

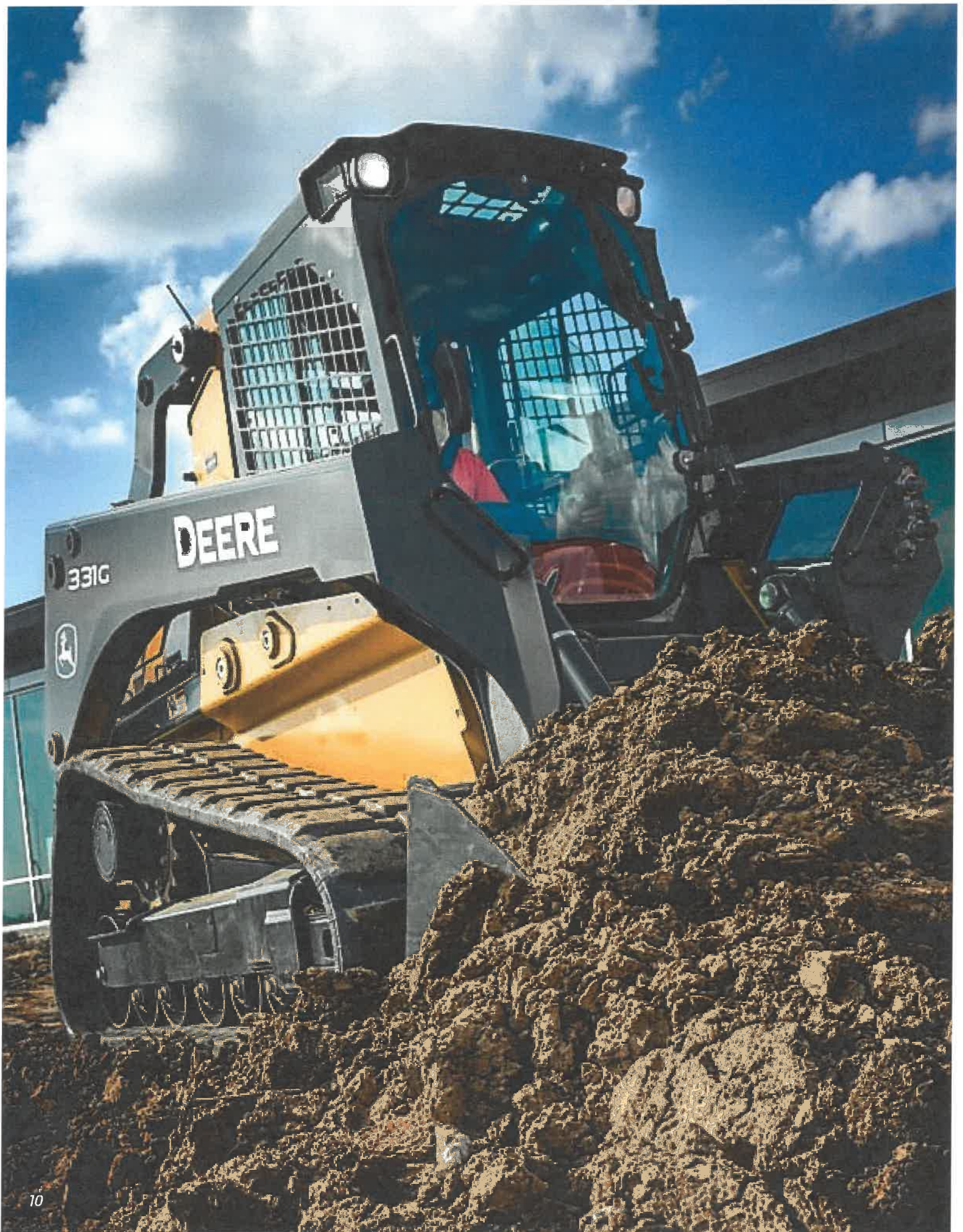

TOUGH ENOUGH

UPTIME YOU CAN BANK ON.

Like all John Deere machines, the G-Series is loaded with features that help save time and money. When you know how they're built, you'll run a Deere.

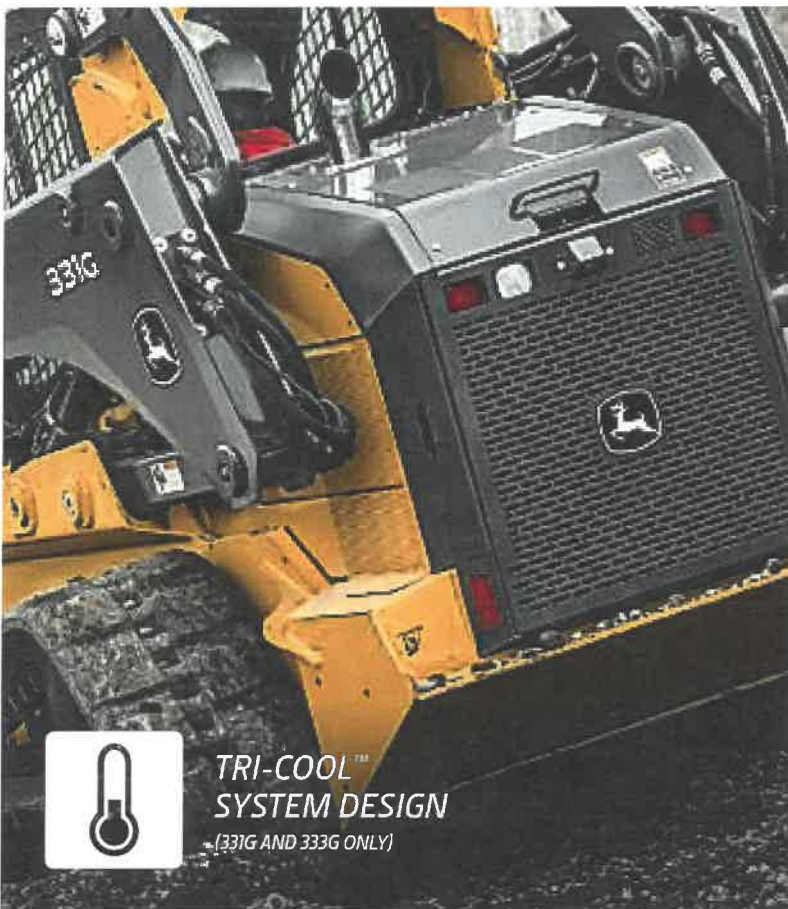

Cool idea

Unique V-plenum (325G) and Tri-Cool (331G and 333G) designs employ large coolers for impressive performance in severe, high-load conditions.

In-boom hydraulics

Auxiliary hydraulic lines and wiring are routed through the boom where they're protected from damage.

Handy component access

These CTLs share components such as engines with our skid steers and compact excavators, which streamlines the filters and fluids you need on hand when you run a Deere fleet.

Beefed-up track components

Track is longer and rollers and idlers are wider on the 331G and 333G, to increase contact area. Plus, spacing has been optimized to help maximize track life.



***WORK OUR
CONNECTIONS.***

***BE MORE THINGS
TO MORE PEOPLE.***

If you're looking for a way to help build your business, John Deere attachments are a great place to start. With more than 100 models, these specialized and general-purpose additions enable you to broaden your abilities, work smarter, and accomplish even more.

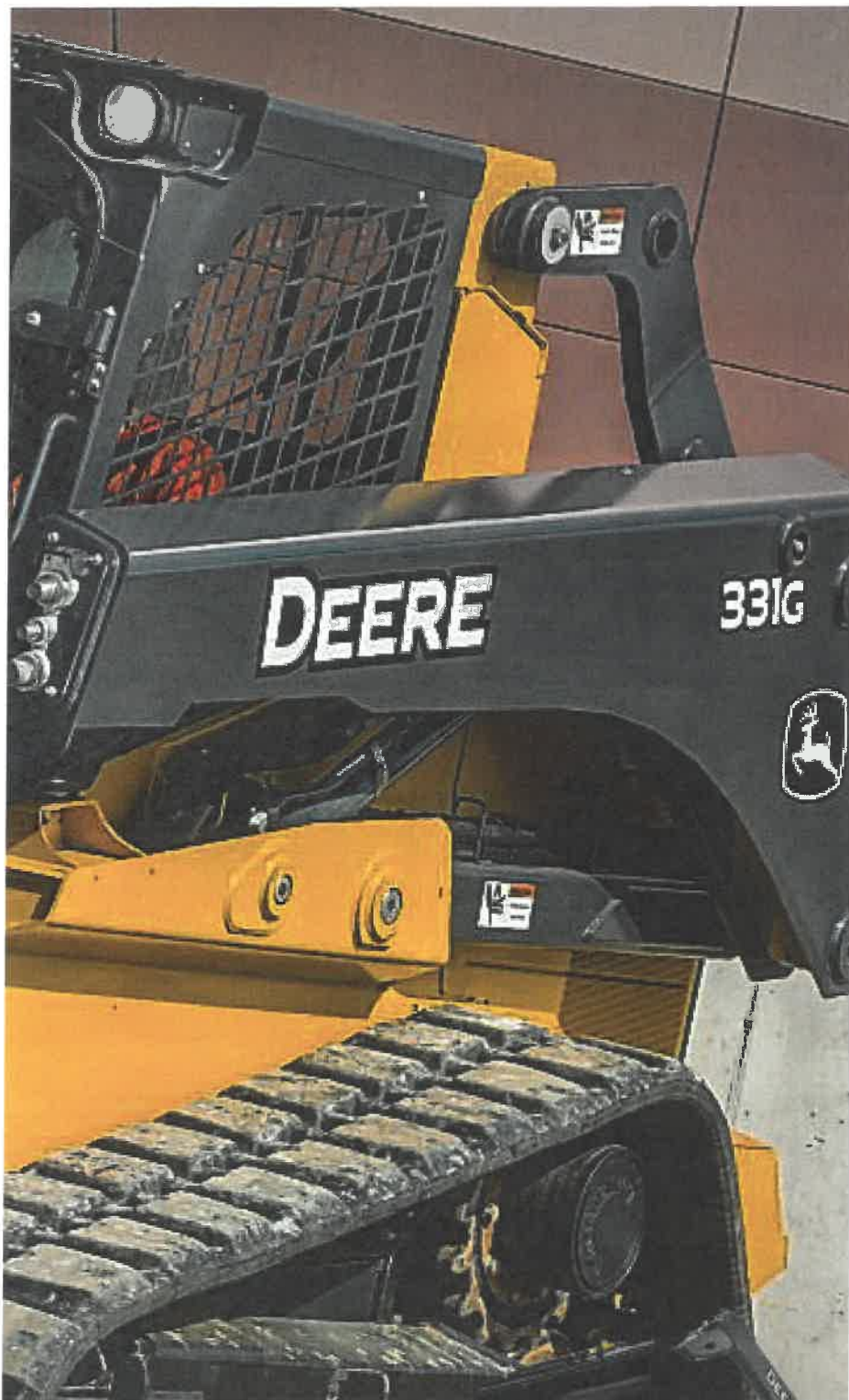

Bucket choices abound

Choose from rock, multipurpose, construction, utility, tooth, grading-heel, and rollout buckets in varying widths and capacities. Extreme-duty 90-in. tooth, serrated, or smooth-edge bucket lets you make the most of every cycle.



Clear it out

A rugged root rake, rotary cutter, or mulching head can help tackle tough land-clearing tasks.

Snow business

Equipped with optional zig-zag-style tracks and a snow blade, blower, or pusher, G-Series machines make quick work of cleaning up whatever winter drops your way.

Streetwise

Perfect for concrete or asphalt flatwork, our angle brooms, vibratory rollers, cold planers, hydraulic hammers, and a wide range of buckets let you hit the ground running.

Landscape tools

Landscape and nursery options include nursery forks, rotary tillers, planetary augers, pallet forks, power rakes, landplanes, dozer blades, and roller levels, to list just a few.

Farm hands

For handling hay, cleaning pens, rebedding stalls, or numerous other agricultural chores, we've got the bale huggers, bale spears, silage defacers, grapples, material/manure scrapers, forks, and buckets to get it done.

Get attached

Universal Quik-Tatch™ enables you to go from bucket, to forks, to whatever, in just seconds, to accomplish more with one machine. Generous standard and optional high-flow auxiliary hydraulics let you effortlessly run powered attachments such as planetary augers, hydraulic hammers, and trenchers.

WE SWEAT THE DETAILS

SO YOU DON'T HAVE TO.

Simplified checks

Color-coded handles and caps on conveniently positioned dipstick and filler necks simplify checks and additions. Handy access eases refills of both fuel and diesel exhaust fluid (DEF)* tanks. See-through reservoirs and sight gauges reveal hydraulic oil and windshield washer fluid levels at a glance.

**331G and 333G only; DEF fluid not required on the 325G.*

Full-tilt service

Tilt the hood up for convenient access from ground level to dipstick, fuel- and fluid-filler necks, and filters. For wide-open drivetrain access, the operator's station swings up and out of the way in less than five minutes.

Generous power

Turbocharged diesels meet rigid emission standards, run smooth, and pack plenty of power and torque.



Easy interior maintenance

If you're a neat freak or run a rental yard, you'll appreciate the convenient cab-footwell floor access that helps speed cleanout. Cab side windows also remove easily for cleaning.

Convenient cooler cleanout

Hinged hood and easy-to-remove side shields yield wide-open access to coolers, simplifying core cleanout. Fan option can be set to automatically reverse to clear core-clogging buildup.

JDLink™ machine monitoring

Optional JDLink provides machine data and health alerts to help you decrease costly downtime.





325G SPECIFICATIONS

Engine		325G
Manufacturer and Model	Yanmar 4TNV98CT	Yanmar 4TNV98T
Non-Road Emission Standard	EPA Final Tier 4/EU Stage IV	EPA Interim Tier 4/EU Stage IIIA
Cylinders	4	4
Gross Rated Power (ISO 14396)	54.8 kW (74 hp) at 2,500 rpm	55.0 kW (74 hp) at 2,500 rpm
Net Power (SAE J1349 / ISO 9249)	52.5 kW (70 hp) at 2,500 rpm	52.7 kW (71 hp) at 2,500 rpm
Peak Torque	280 Nm (207 lb.-ft.) at 1,800 rpm	284 Nm (209 lb.-ft.) at 1,800 rpm
Displacement	3.3 L (203 cu. in.)	3.3 L (203 cu. in.)
Rated Engine Speed	2,500 rpm	2,500 rpm
Torque Rise	34% at 1,800 rpm	36% at 1,800 rpm
Aspiration	Turbocharged	Turbocharged
Air Cleaner	Dry dual element	Dry dual element
Cooling		
Fan Type	Variable-speed hydraulic drive standard / reversing fan drive optional	
Powertrain		
Pump	Axial-piston hydrostatic	
Controls	Electrohydraulic	
Travel Speeds		
Single Speed, Standard	9.3 km/h (5.8 mph)	
2 Speed, Optional		
Low	8.4 km/h (5.2 mph)	
High	13.2 km/h (8.2 mph)	
Brake	Integral, automatic, spring-applied, hydraulically released wet-disc brake	
Undercarriage		
Rubber Tracks	Smooth-ride long-life rubber with steel inserts	
Track Width		
Standard	320 mm (12.6 in.)	
Optional	400 mm (15.8 in.)	
Ground Pressure		
Standard 320-mm (12.6 in.) Track	39.3 kPa (5.7 psi)	
Optional 400-mm (15.8 in.) Track	32.4 kPa (4.7 psi)	
Track Rollers (per side)	4 triple-flange smooth-ride all-steel rollers	
Track Idlers (per side)	2 double-flange smooth-ride all-steel rollers	
Bearings/Seals (rollers/idlers)	Heavy-duty journal bearings and metal face seals	
Tractive Effort	3859 kgf (8,500 lbf)	
Hydraulics		
Pump Flow		
Standard	70 L/m (19 gpm)	
Total with High-Flow Option	101 L/m (27 gpm)	
System Pressure at Couplers	23 787 kPa (3,450 psi)	
Hydraulic Horsepower Flow (calculated)		
Standard	27.9 kW (37.4 hp)	
High	40.1 kW (53.7 hp)	
Cylinders		
Type	John Deere heat-treated, chrome-plated polished cylinder rods, hardened steel (replaceable bushings) pivot pins	

325G SPECIFICATIONS



325G COMPACT TRACK LOADER

Electrical	325G
Voltage	12 volt
Battery Capacity	750 CCA standard / 925 CCA optional
Alternator Rating	75 amp
Lights	Halogen, 2 front and 1 rear

Operator's Station
ROPS (ISO 3471) / FOPS (ISO 3449) structure with quick-pivot standard

Serviceability

Refill Capacity
Fuel Tank 79 L (21 gal.)

Operating Weights

	<i>EPA Final Tier 4/EU Stage IV and EPA Interim Tier 4/EU Stage IIIA</i>
With Standard 320-mm (12.6 in.) Track	4313 kg (9,500 lb.)
With Optional 400-mm (15.8 in.) Track	4381 kg (9,650 lb.)

Machine Dimensions

A Length without Bucket	2.85 m (112.3 in.) (9 ft. 4 in.)
B Length with Foundry Bucket	3.46 m (136.3 in.) (11 ft. 4 in.)
C Width without Bucket	
With 320-mm (12.6 in.) Track	1.82 m (71.5 in.) (6 ft. 0 in.)
With 400-mm (15.8 in.) Track	1.90 m (74.7 in.) (6 ft. 3 in.)
D Height to Top of ROPS	2.06 m (81.1 in.) (6 ft. 9 in.)
E Height to Hinge Pin	3.20 m (126.1 in.) (10 ft. 6 in.)
F Dump Height with Foundry Bucket	2.59 m (102.1 in.) (8 ft. 6 in.)
G Dump Reach	
With Foundry Bucket	0.75 m (29.7 in.)
With Construction Bucket with Edge	0.94 m (37 in.) (3 ft. 1 in.)
H Ground Clearance	0.24 m (9.3 in.)
I Angle of Departure	30.5 deg.
J Front Turn Radius with Foundry Bucket	2.03 m (80 in.) (6 ft. 8 in.)
K Dump Angle (full lift height)	41 deg.
L Bucket Rollback (ground level)	34 deg.

Loader Performance

	<i>EPA Final Tier 4/EU Stage IV and EPA Interim Tier 4/EU Stage IIIA</i>
Tipping Load	3360 kg (7,400 lb.)
SAE Rated Operating Capacity with Foundry Bucket	
At 35% Tipping Load	1176 kg (2,590 lb.)
At 50% Tipping Load	1634 kg (3,600 lb.)
Boom Breakout Force	
With Foundry Bucket	2384 kg (5,250 lb.)
With Construction Bucket	2154 kg (4,750 lb.)
Bucket Breakout Force	
With Foundry Bucket	3973 kg (8,750 lb.)
With Construction Bucket	2724 kg (6,000 lb.)

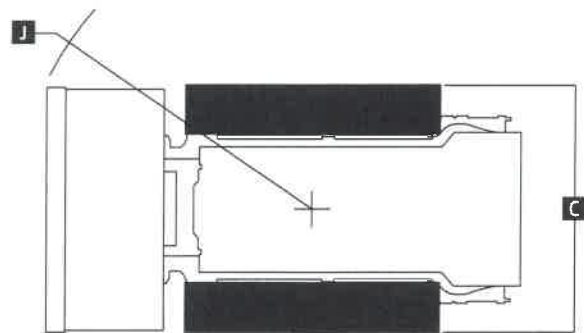
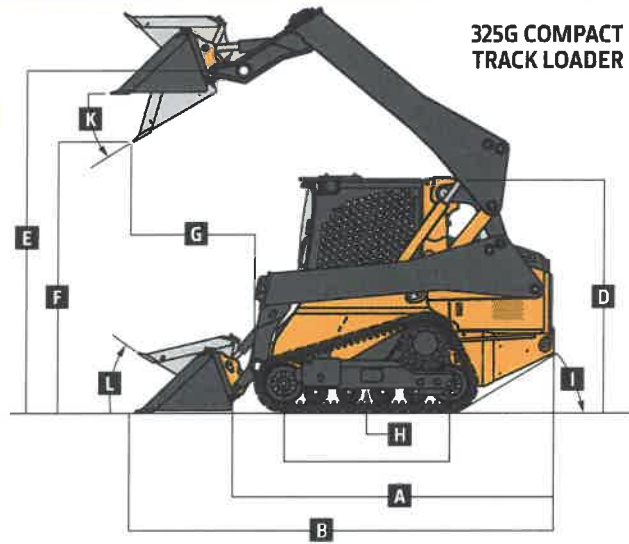



331G / 333G SPECIFICATIONS

Engine	331G		333G	
Manufacturer and Model	Yanmar 4TNV94FHT	Yanmar 4TNV94CHT	Yanmar 4TNV94FHT	Yanmar 4TNV94CHT
Non-Road Emission Standards	EPA Final Tier 4/ EU Stage IV	EPA Interim Tier 4/ EU Stage IIIB	EPA Final Tier 4/ EU Stage IV	EPA Interim Tier 4/ EU Stage IIIB
Cylinders	4	4	4	4
Gross Rated Power (ISO 14396)	68.0 kW (91.2 hp) at 2,500 rpm		74.6 kW (100 hp) at 2,500 rpm	
Net Peak Power (SAE J1349 / ISO 9249)	66.0 kW (88.5 hp) at 2,500 rpm		72.0 kW (96.6 hp) at 2,500 rpm	
Peak Torque	382 Nm (281.8 ft.-lb.) at 1,700 rpm		395 Nm (291.3 ft.-lb.) at 1,700 rpm	
Displacement	3.1 L (186.3 cu. in.)	3.1 L (186.3 cu. in.)	3.1 L (186.3 cu. in.)	3.1 L (186.3 cu. in.)
Rated Engine Speed	2,500 rpm	2,500 rpm	2,500 rpm	2,500 rpm
Torque Rise	47% at 1,700 rpm	47% at 1,700 rpm	39% at 1,700 rpm	39% at 1,700 rpm
Aspiration	Turbocharged, intercooled	Turbocharged, intercooled	Turbocharged, intercooled	Turbocharged, intercooled
Air Cleaner	Dry dual element	Dry dual element	Dry dual element	Dry dual element
Cooling	331G / 333G			
Fan Type	Variable-speed hydraulic drive standard / reversing fan drive optional			
Powertrain	331G		333G	
Pump	Axial-piston hydrostatic		Axial-piston hydrostatic	
Controls	Electrohydraulic		Electrohydraulic	
Travel Speeds				
Low	8.5 km/h (5.3 mph)		8.5 km/h (5.3 mph)	
High	12.6 km/h (7.8 mph)		12.6 km/h (7.8 mph)	
Brakes	Integral, automatic, spring-applied, hydraulically released wet-disc brake			
Undercarriage				
Rubber Tracks	Smooth-ride long-life rubber with steel inserts			
Track Width				
Standard	400 mm (15.8 in.)		450 mm (17.7 in.)	
Optional	450 mm (17.7 in.)		400 mm (15.8 in.)	
Ground Pressure				
400-mm (15.8 in.) Track (standard on 331G / optional on 333G)	38.1 kPa (5.5 psi)		38.4 kPa (5.6 psi)	
450-mm (17.7 in.) Track (optional on 331G / standard on 333G)	33.9 kPa (4.9 psi)		34.1 kPa (5.0 psi)	
Track Rollers (per side)	5 triple-flange smooth-ride all-steel rollers		5 triple-flange smooth-ride all-steel rollers	
Track Idlers (per side)	2 double-flange smooth-ride all-steel rollers		2 double-flange smooth-ride all-steel rollers	
Bearings/Seals (rollers/idlers)	Heavy-duty journal bearings and metal face seals		Heavy-duty journal bearings and metal face seals	
Tractive Effort	5221 kgf (11,500 lbf)		5221 kgf (11,500 lbf)	
Hydraulics				
Pump Flow				
Standard	80 L/m (23.5 gpm)		95 L/m (25.0 gpm)	
Total with High-Flow Option	138 L/m (36.5 gpm)		156 L/m (41.1 gpm)	
System Pressure at Couplers	23 787 kPa (3,450 psi)		23 787 kPa (3,450 psi)	
Hydraulic Horsepower Flow (calculated)				
Standard	35 kW (47 hp)		38 kW (50 hp)	
High	55 kW (74 hp)		62 kW (83 hp)	
Cylinders	331G / 333G			
Type	John Deere heat-treated, chrome-plated, polished cylinder rods, hardened steel (replaceable bushings) pivot pins			
Electrical				
Voltage	12 volt			
Battery Capacity	925 CCA			
Alternator Rating	90 amp			
Lights	Halogen: 2 front and 1 rear standard / deluxe LED: 4 front and 1 rear optional			
Operator's Station				
ROPS (ISO 3471) / FOPS (ISO 3449) structure with quick-pivot standard				
Serviceability				
Refill Capacity				
Fuel Tank	114 L (30 gal.)			

331G / 333G SPECIFICATIONS



Operating Weight		331G	333G
		<i>EPA Final Tier 4/ EU Stage IV</i>	<i>EPA Interim Tier 4/ EU Stage IIIB</i>
With Standard 400-mm (15.8 in.) Track		5403 kg (11,900 lb.)	—
With Standard 450-mm (17.7 in.) Track		—	5493 kg (12,100 lb.)
		<i>EPA Final Tier 4/ EU Stage IV</i>	<i>EPA Interim Tier 4/ EU Stage IIIB</i>
		—	5448 kg (12,000 lb.)
Machine Dimensions		331G / 333G	
A Length without Bucket		3.10 m (122 in.) (10 ft. 2 in.)	
B Length with Foundry Bucket		3.71 m (146 in.) (12 ft. 2 in.)	
C Width without Bucket		2.00 m (78.9 in.) (6 ft. 7 in.)	
With 400-mm (15.8 in.) Track		2.05 m (80.7 in.) (6 ft. 9 in.)	
D Height to Top of ROPS		2.20 m (86.7 in.) (7 ft. 3 in.)	
E Height to Hinge Pin		3.35 m (132 in.) (11 ft. 0 in.)	
F Dump Height with Foundry Bucket		2.69 m (106.1 in.) (8 ft. 10 in.)	
G Dump Reach		0.71 m (28 in.)	
With Foundry Bucket		0.88 m (34.6 in.)	
H Ground Clearance		0.24 m (9.4 in.)	
I Angle of Departure		31 deg.	
J Front Turn Radius with Foundry Bucket		2.18 m (85.7 in.) (7 ft. 2 in.)	
K Dump Angle (full lift height)		48 deg.	
L Bucket Rollback (ground level)		35 deg.	

331G / 333G COMPACT TRACK LOADERS

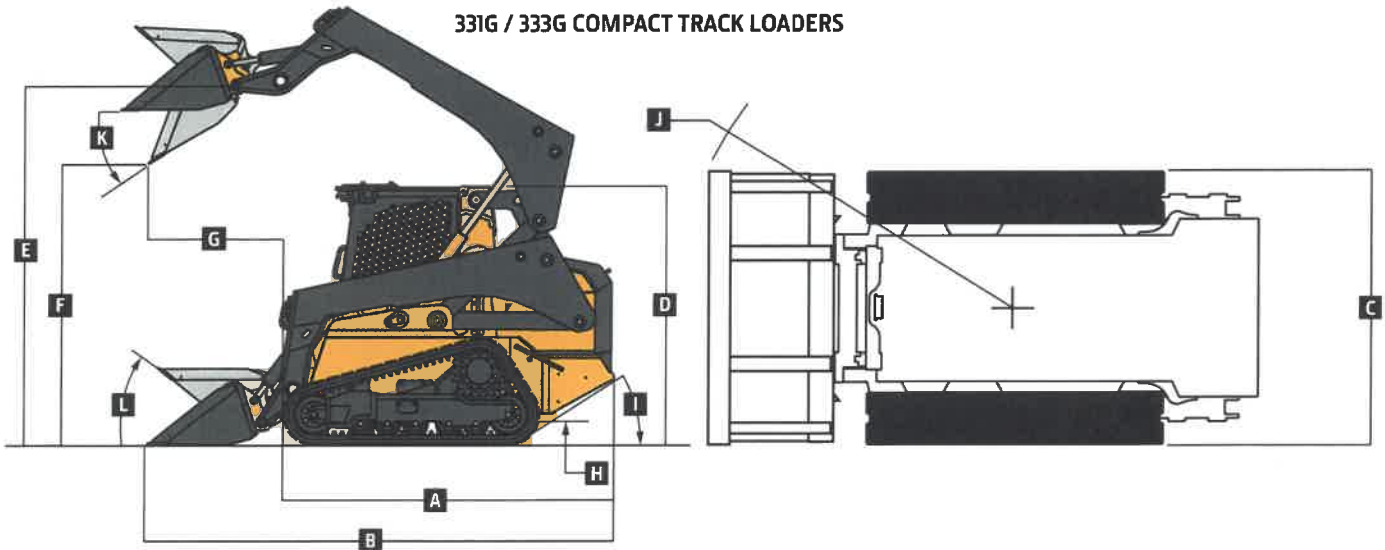

Loader Performance		331G	333G
		<i>EPA Final Tier 4/EU Stage IV and EPA Interim Tier 4/EU Stage IIIB</i>	<i>EPA Final Tier 4/EU Stage IV and EPA Interim Tier 4/EU Stage IIIB</i>
Tipping Load with Foundry Bucket		4021 kg (8,857 lb.)	4799 kg (10,570 lb.)
SAE Rated Operating Capacity			
At 35% Tipping Load		1407 kg (3,100 lb.)	1680 kg (3,700 lb.)
At 50% Tipping Load		2011 kg (4,429 lb.)	2399 kg (5,285 lb.)
Boom Breakout Force			
With Foundry Bucket		2724 kg (6,000 lb.)	3746 kg (8,250 lb.)
With Construction Bucket		2724 kg (6,000 lb.)	3519 kg (7,750 lb.)
Bucket Breakout Force			
With Foundry Bucket		4688 kg (10,325 lb.)	6243 kg (13,750 lb.)
With Heavy-Duty Construction Bucket		3450 kg (7,600 lb.)	4200 kg (9,250 lb.)

Additional equipment

Key: ● Standard ▲ Optional or special

See your John Deere dealer for further information.

325G	331G	333G	Engine
●	●	●	Meets EPA Final Tier 4/EU Stage IV emissions
▲			Meets EPA Interim Tier 4/EU Stage IIIA emissions
	▲	▲	Meets EPA Interim Tier 4/EU Stage IIIB emissions
●			Yanmar 4TNV98CT
▲			Yanmar 4TNV98T
	●	●	Yanmar 4TNV94FHT
	▲	▲	Yanmar 4TNV94CHT
●	●	●	Auto-idle
●	●	●	Automatic fan tensioner
●	●	●	Automatic preheat
●	●	●	Electronic injection system
▲	▲	▲	Engine air precleaner kit
●			Fuel tank, 79 L (21 gal.)
	●	●	Fuel tank, 114 L (30 gal.)
●	●	●	John Deere COOL-GARD™ II Extended-Life Engine Coolant
●	●	●	John Deere Plus-50™ 10w30 initial engine oil fill [†]
●			4-cylinder 54.8 kW (74 gross hp) / 52.5 kW (70 net hp), 3.3-L (203 cu. in.) displacement
	●		4-cylinder 68.0 kW (91.2 gross hp) / 66.0 kW (88.5 net hp), 3.1-L (186.3 cu. in.) displacement
		●	4-cylinder 74.6 kW (100 gross hp) / 72.0 kW (96.6 net hp), 3.1-L (186.3 cu. in.) displacement
●	●	●	5-micron primary fuel filter and water separator
▲	▲	▲	Cold-weather starting package
Cooling System			
●	●	●	Coolant surge tank
●	●	●	Variable-speed hydraulically driven fan cooling system
▲	▲	▲	Reversing fan drive
Powertrain			
●	●	●	High-torque heavy-duty planetary-reduction final drive
●	●	●	Automatic spring-applied hydraulically released wet-disc park brake
●	●	●	Wet-disc brakes
●	●	●	Transmission, single speed
▲	●	●	Transmission, 2 speed
Hydraulic System			
●	●	●	John Deere hydraulic cylinders with cushioned boom cylinders
●	●	●	John Deere heat-treated, chrome-plated cylinder rods with replaceable bushings
●	●	●	Connect-under-pressure auxiliary couplers
●	●	●	Quick-check hydraulic fluid-level sight glass
●	●	●	1,000-hour, 5-micron hydraulic filter

325G	331G	333G	Hydraulic System (continued)
▲	▲	▲	High-flow hydraulics
●	●	●	Axial-piston hydrostatic pump
Electrical			
●	●	●	Automatic engine/hydraulic shutdown protection system
●	●	●	Auxiliary hydraulics operator-presence system
●	●	●	Courtesy lighting
●	●	●	Deluxe instrumentation EMU with: Operator-selectable monitoring – Hour meter, engine rpm, battery voltage, diagnostics, EMU configuration, engine coolant temperature, hydraulic oil temperature / LED warning indicators – Glow plug, seat switch, seat belt, door open, auxiliary hydraulics, park brake engaged, 2-speed engaged, stop, low engine oil pressure, engine coolant over-temperature, battery not charging, air filter restriction, and hydraulic filter restriction
▲	▲	▲	Deluxe LED lighting package with additional cab-integrated side lights (2)
●	●	●	Front and rear halogen work lights
●	●	●	Triple-interlock operator-presence control system
●	●	●	Backup alarm
●	●	●	Battery, 750 CCA
▲	●	●	Battery, 925 CCA
●	●	●	Horn
▲	▲	▲	Hazard warning lights
▲	▲	▲	Strobe light, amber
Operator's Station			
●	●	●	Deluxe cab headliner
●	●	●	Electrohydraulic (EH) ISO-pattern joystick controls
▲	▲	▲	ISO-H switchable joystick controls and EH joystick performance package*
	▲	▲	EH 4-way switchable controls include EH foot control, ISO joystick control, H-pattern joystick control, and ISO and foot controls
	▲	▲	ISO controls with programmable detents and EH boom performance package;† also includes EH joystick performance package*
	▲	▲	Onboard grade indication: Grade-control option delivers onboard readout within LCD monitor that provides slope of blade (cross-slope direction) and mainfall (fore/aft direction) within ±0.5-percent accuracy
▲	●	●	Keyless-start sealed-switch module with integrated anti-theft system and operator memory preference settings
●	●	●	Electronic push-button auxiliary controls
●	●	●	Pull-down adjustable lap bar
●	●	●	Quick-pivot ROPS
●	●	●	Rear window

325G	331G	333G	Operator's Station (continued)
●	●	●	Removable top window
▲	▲	▲	Sliding/locking/removable glass side windows
●	●	●	ROPS/FOPS operator structure
▲	▲	▲	Glass cab enclosure
●	●	●	Seat belt, 51 mm (2 in.), retractable
▲	▲	▲	Shoulder belt, 51 mm (2 in.) or 76 mm (3 in.)
▲	▲	▲	Severe-duty cab door and wiper system
●	●	●	Water-shedding deluxe vinyl suspension seat
▲	▲	▲	Air-ride cloth, heated seat
▲	▲	▲	Air-ride vinyl seat
●	●	●	12-volt power port / Dome light / Cargo storage / Beverage holder
▲	▲	▲	Air conditioning with heater/defroster
▲	▲	▲	AM/FM radio with auxiliary input and Bluetooth® for audio streaming
▲	▲	▲	Floor mat with left footrest
●	●	●	Rearview mirror
▲	▲	▲	Rearview camera
Loader			
●	●	●	In-cab boom lockout to secure loader before exiting seat
●	●	●	Patented John Deere Quik-Tatch™ (no grease required)
▲	▲	▲	Patented John Deere vertical-lift boom
▲	▲	▲	Hydraulic self-leveling on/off and ride control
Other			
●	●	●	Convenient front and rear tie-downs
●	●	●	Environmental drains for all fluid reservoirs
▲	▲	▲	Chrome exhaust stack
▲	▲	▲	Engine oil/hydraulic fluid-sampling kit
▲	▲	▲	Forestry protection packages
▲	▲	▲	Heavy-duty rear grille
▲	▲	▲	Rear counterweights (available in sets of 1, 2, or 3), 78 kg (172 lb.) (each set)
▲	▲	▲	Single-point lift kit
▲	▲	▲	SMV sign kit
●	●	●	Track, 320-mm (12.6 in.) wide
▲	●	▲	Track, 400-mm (15.8 in.) wide
	▲	●	Track, 450-mm (17.7 in.) wide
▲	▲	▲	JDLINK™ wireless communication system (available in specific countries; see your dealer for details)

[†]500-hour engine oil-change intervals when John Deere Plus-50 oil and John Deere oil filter are used.

*EH joystick performance package features switchable accelerator/decelerator, selectable propel speeds, creep control, boom- and bucket-speed settings, and 12-volt 3- and 14-pin attachment-control harness with dash-mounted 4th-function rocker switch.

†EH boom performance package features include EH bucket self-level up and down, return to dig, return to carry, and boom-height kick-out.



Net engine power is with standard equipment including air cleaner, exhaust system, alternator, and cooling fan, at standard conditions per SAE J1349 and DIN 6270B, using No. 2-D fuel at 35 API gravity. Gross power is without cooling fan. Specifications and design subject to change without notice. Wherever applicable, specifications are in accordance with SAE standards. Except where otherwise noted, these specifications are based on units with standard equipment, full fuel tanks, and 79-kg (175-lb.) operator.

JohnDeere.com