



West Virginia Purchasing Division

2019 Washington Street, East
Charleston, WV 25305
Telephone: 304-558-2306
General Fax: 304-558-6026
Bid Fax: 304-558-3970

The following documentation is an electronically-submitted vendor response to an advertised solicitation from the *West Virginia Purchasing Bulletin* within the Vendor Self-Service portal at wvOASIS.gov. As part of the State of West Virginia's procurement process, and to maintain the transparency of the bid-opening process, this documentation submitted online is publicly posted by the West Virginia Purchasing Division at WVPurchasing.gov with any other vendor responses to this solicitation submitted to the Purchasing Division in hard copy format.

Header @ 2

List View

General Information | Contact | Default Values | Discount | Document Information | Clarification Request

Procurement Folder: 768046

Procurement Type: Central Purchase Order

Vendor ID: 000000176773

Legal Name: GRAE CON CONSTRUCTION INC

Alias/DBA:

Total Bid: \$67,000.00

Response Date: 09/21/2020

Response Time: 12:02

Responded By User ID: GraeConCons

First Name: Kayla

Last Name: Stock

Email: kstock@graecon.com

Phone: 740-282-6830

SO Doc Code: CRFQ

SO Dept: 0211

SO Doc ID: GSD2100000012

Published Date: 9/17/20

Close Date: 9/21/20

Close Time: 13:30

Status: Closed

Solicitation Description: Water Pump/Motor Skid Replacement B.11

Total of Header Attachments: 2

Total of All Attachments: 2



Department of Administration
 Purchasing Division
 2019 Washington Street East
 Post Office Box 50130
 Charleston, WV 25305-0130

**State of West Virginia
 Solicitation Response**

Proc Folder: 768046
Solicitation Description: Water Pump/Motor Skid Replacement B.11
Proc Type: Central Purchase Order

Solicitation Closes	Solicitation Response	Version
2020-09-21 13:30	SR 0211 ESR09212000000002564	1

VENDOR
 000000176773
 GRAE CON CONSTRUCTION INC

Solicitation Number: CRFQ 0211 GSD2100000012

Total Bid: 67000

Response Date: 2020-09-21

Response Time: 12:02:26

Comments:

FOR INFORMATION CONTACT THE BUYER

Melissa Pettrey
 (304) 558-0094
 melissa.k.pettrey@wv.gov

Vendor Signature X **FEIN#** **DATE**

All offers subject to all terms and conditions contained in this solicitation

Line	Comm Ln Desc	Qty	Unit Issue	Unit Price	Ln Total Or Contract Amount
1	Water Pump/Motor Skid Replacement	1.00000	LS	67000.000000	67000.00

Comm Code	Manufacturer	Specification	Model #
83101510			

Commodity Line Comments: Please see attached bid form and Clarifications/Qualifications sheet

Extended Description:

Water Pump/Motor Skid Replacement per attached specifications



Department of Administration
 Purchasing Division
 2019 Washington Street East
 Post Office Box 50130
 Charleston, WV 25305-0130

State of West Virginia
 Centralized Request for Quote
 Construction

Proc Folder: 768046		Reason for Modification:	
Doc Description: Water Pump/Motor Skid Replacement B.11			
Proc Type: Central Purchase Order			
Date Issued	Solicitation Closes	Solicitation No	Version
2020-09-02	2020-09-21 13:30	CRFQ 0211 GSD2100000012	1

BID RECEIVING LOCATION

BID CLERK
 DEPARTMENT OF ADMINISTRATION
 PURCHASING DIVISION
 2019 WASHINGTON ST E
 CHARLESTON WV 25305
 US

VENDOR

Vendor Customer Code: 34-1539132
 Vendor Name : Grae-Con Construction, Inc.
 Address : PO Box 1778
 Street : 880 Kingsdale Road
 City : Steubenville
 State : Ohio Country : USA Zip : 43952
 Principal Contact : Robert A. Gribben, III - Vice President
 Vendor Contact Phone: (740)282-6830 Extension: 1205

FOR INFORMATION CONTACT THE BUYER
 Melissa Pettrey
 (304) 558-0094
 melissa.k.pettrey@wv.gov

Vendor Signature X *Robert A. Gribben III* /s/ PEIN# 34-1539132 DATE September 21, 2020

All offers subject to all terms and conditions contained in this solicitation

ADDITIONAL INFORMATIONRequest for Quotation
Construction

The West Virginia Purchasing Division is soliciting bids on behalf of the WV Department of Administration, General Services Division to establish a contract for the installation of one (1) Water Pump/Motor Skid replacement.
The Vendor shall furnish all materials, labor, and equipment necessary to complete all Construction Services per the Specifications, Project Plans and Terms and Conditions as attached hereto.

INVOICE TO	SHIP TO
DEPARTMENT OF ADMINISTRATION GENERAL SERVICES DIVISION 112 CALIFORNIA AVENUE, 5TH FLOOR CHARLESTON WV 25305 US	DEPARTMENT OF ADMINISTRATION GENERAL SERVICES DIVISION BLDG 11 - CHILLER PLANT 218 CALIFORNIA AVE CHARLESTON WV 25305 US

Line	Comm Ln Desc	Qty	Unit Issue
1	Water Pump/Motor Skid Replacement	1.00000	LS

Comm Code	Manufacturer	Specification	Model #
83101510			

Extended Description:
Water Pump/Motor Skid Replacement per attached specifications

SCHEDULE OF EVENTS

Line	Event	Event Date
1	Mandatory Pre-bid 10:00 A.M.	2020-09-10
2	Technical Question Due by 3:00 P.M.	2020-09-14

INSTRUCTIONS TO VENDORS SUBMITTING BIDS

1. REVIEW DOCUMENTS THOROUGHLY: The attached documents contain a solicitation for bids. Please read these instructions and all documents attached in their entirety. These instructions provide critical information about requirements that if overlooked could lead to disqualification of a Vendor's bid. All bids must be submitted in accordance with the provisions contained in these instructions and the Solicitation. Failure to do so may result in disqualification of Vendor's bid.

2. MANDATORY TERMS: The Solicitation may contain mandatory provisions identified by the use of the words "must," "will," and "shall." Failure to comply with a mandatory term in the Solicitation will result in bid disqualification.

3. PREBID MEETING: The item identified below shall apply to this Solicitation.

A pre-bid meeting will not be held prior to bid opening

A **MANDATORY PRE-BID** meeting will be held at the following place and time:

218 California Avenue (Building 11),
Second Floor Conference Room
Charleston, WV 25305

09/10/2020 at 10:00 A.M.

All Vendors submitting a bid must attend the mandatory pre-bid meeting. Failure to attend the mandatory pre-bid meeting shall result in disqualification of the Vendor's bid. No one individual is permitted to represent more than one vendor at the pre-bid meeting. Any individual that does attempt to represent two or more vendors will be required to select one vendor to which the individual's attendance will be attributed. The vendors not selected will be deemed to have not attended the pre-bid meeting unless another individual attended on their behalf.

An attendance sheet provided at the pre-bid meeting shall serve as the official document verifying attendance. Any person attending the pre-bid meeting on behalf of a Vendor must list on the attendance sheet his or her name and the name of the Vendor he or she is representing.

Additionally, the person attending the pre-bid meeting should include the Vendor's E-Mail address, phone number, and Fax number on the attendance sheet. It is the Vendor's responsibility to locate the attendance sheet and provide the required information. Failure to complete the attendance sheet as required may result in disqualification of Vendor's bid.

All Vendors should arrive prior to the starting time for the pre-bid. Vendors who arrive after the starting time but prior to the end of the pre-bid will be permitted to sign in but are charged with knowing all matters discussed at the pre-bid.

Questions submitted at least five business days prior to a scheduled pre-bid will be discussed at the pre-bid meeting if possible. Any discussions or answers to questions at the pre-bid meeting
Revised 01/09/2020

are preliminary in nature and are non-binding. Official and binding answers to questions will be published in a written addendum to the Solicitation prior to bid opening.

4. VENDOR QUESTION DEADLINE: Vendors may submit questions relating to this Solicitation to the Purchasing Division. Questions must be submitted in writing. All questions must be submitted on or before the date listed below and to the address listed below in order to be considered. A written response will be published in a Solicitation addendum if a response is possible and appropriate. Non-written discussions, conversations, or questions and answers regarding this Solicitation are preliminary in nature and are nonbinding.

Submitted e-mails should have solicitation number in the subject line.

Question Submission Deadline: 09/14/2020 by 3:00pm

Submit Questions to: Melissa K Pettrey, Senior Buyer
2019 Washington Street, East
Charleston, WV 25305
Fax: (304) 558-4115 (Vendors should not use this fax number for bid submission)
Email: Melissa.K.Pettrey@wv.gov

5. VERBAL COMMUNICATION: Any verbal communication between the Vendor and any State personnel is not binding, including verbal communication at the mandatory pre-bid conference. Only information issued in writing and added to the Solicitation by an official written addendum by the Purchasing Division is binding.

6. BID SUBMISSION: All bids must be submitted electronically through wvOASIS or signed and delivered by the Vendor to the Purchasing Division at the address listed below on or before the date and time of the bid opening. Any bid received by the Purchasing Division staff is considered to be in the possession of the Purchasing Division and will not be returned for any reason. The Purchasing Division will not accept bids, modification of bids, or addendum acknowledgment forms via e-mail. Acceptable delivery methods include electronic submission via wvOASIS, hand delivery, delivery by courier, or facsimile.

The bid delivery address is:
Department of Administration, Purchasing Division
2019 Washington Street East
Charleston, WV 25305-0130

A bid that is not submitted electronically through wvOASIS should contain the information listed below on the face of the envelope or the bid may be rejected by the Purchasing Division.:

SEALED BID: Water Pump/Motor Skid Replacement B.11
BUYER: Melissa K. Pettrey, Senior Buyer
SOLICITATION NO.: CRFQ 0211 GSD210000012
BID OPENING DATE: 09/21/2020
BID OPENING TIME: 1:30pm
FAX NUMBER: 304-558-3970

Revised 01/09/2020

The Purchasing Division may prohibit the submission of bids electronically through wvOASIS at its sole discretion. Such a prohibition will be contained and communicated in the wvOASIS system resulting in the Vendor's inability to submit bids through wvOASIS. Submission of a response to an Expression of Interest or Request for Proposal is not permitted in wvOASIS.

For Request For Proposal ("RFP") Responses Only: In the event that Vendor is responding to a request for proposal, the Vendor shall submit one original technical and one original cost proposal plus N/A convenience copies of each to the Purchasing Division at the address shown above. Additionally, the Vendor should identify the bid type as either a technical or cost proposal on the face of each bid envelope submitted in response to a request for proposal as follows:

BID TYPE: (This only applies to CRFP)

Technical

Cost

7. BID OPENING: Bids submitted in response to this Solicitation will be opened at the location identified below on the date and time listed below. Delivery of a bid after the bid opening date and time will result in bid disqualification. For purposes of this Solicitation, a bid is considered delivered when confirmation of delivery is provided by wvOASIS (in the case of electronic submission) or when the bid is time stamped by the official Purchasing Division time clock (in the case of hand delivery).

Bid Opening Date and Time: 09/21/2020 at 1:30pm

Bid Opening Location: Department of Administration, Purchasing Division
2019 Washington Street East
Charleston, WV 25305-0130

8. ADDENDUM ACKNOWLEDGEMENT: Changes or revisions to this Solicitation will be made by an official written addendum issued by the Purchasing Division. Vendor should acknowledge receipt of all addenda issued with this Solicitation by completing an Addendum Acknowledgment Form, a copy of which is included herewith. Failure to acknowledge addenda may result in bid disqualification. The addendum acknowledgement should be submitted with the bid to expedite document processing.

9. BID FORMATTING: Vendor should type or electronically enter the information onto its bid to prevent errors in the evaluation. Failure to type or electronically enter the information may result in bid disqualification.

10. ALTERNATE MODEL OR BRAND: Unless the box below is checked, any model, brand, or specification listed in this Solicitation establishes the acceptable level of quality only and is not intended to reflect a preference for, or in any way favor, a particular brand or vendor. Vendors may bid alternates to a listed model or brand provided that the alternate is at least equal to the model or brand and complies with the required specifications. The equality of any alternate being bid shall be determined by the State at its sole discretion. Any Vendor bidding an alternate model or brand should clearly identify the alternate items in its bid and should include manufacturer's specifications, industry literature, and/or any other relevant documentation demonstrating the

Revised 01/09/2020

equality of the alternate items. Failure to provide information for alternate items may be grounds for rejection of a Vendor's bid.

This Solicitation is based upon a standardized commodity established under W. Va. Code § 5A-3-61. Vendors are expected to bid the standardized commodity identified. Failure to bid the standardized commodity will result in your firm's bid being rejected.

11. EXCEPTIONS AND CLARIFICATIONS: The Solicitation contains the specifications that shall form the basis of a contractual agreement. Vendor shall clearly mark any exceptions, clarifications, or other proposed modifications in its bid. Exceptions to, clarifications of, or modifications of a requirement or term and condition of the Solicitation may result in bid disqualification.

12. COMMUNICATION LIMITATIONS: In accordance with West Virginia Code of State Rules §148-1-6.6, communication with the State of West Virginia or any of its employees regarding this Solicitation during the solicitation, bid, evaluation or award periods, except through the Purchasing Division, is strictly prohibited without prior Purchasing Division approval. Purchasing Division approval for such communication is implied for all agency delegated and exempt purchases.

13. REGISTRATION: Prior to Contract award, the apparent successful Vendor must be properly registered with the West Virginia Purchasing Division and must have paid the \$125 fee, if applicable.

14. UNIT PRICE: Unit prices shall prevail in cases of a discrepancy in the Vendor's bid.

15. PREFERENCE: Vendor Preference may be requested in purchases of motor vehicles or construction and maintenance equipment and machinery used in highway and other infrastructure projects. Any request for preference must be submitted in writing with the bid, must specifically identify the preference requested with reference to the applicable subsection of West Virginia Code § 5A-3-37, and must include with the bid any information necessary to evaluate and confirm the applicability of the requested preference. A request form to help facilitate the request can be found at:

<http://www.state.wv.us/admin/purchase/vrc/Venpref.pdf>.

15A. RECIPROCAL PREFERENCE: The State of West Virginia applies a reciprocal preference to all solicitations for commodities and printing in accordance with W. Va. Code § 5A-3-37(b). In effect, non-resident vendors receiving a preference in their home states, will see that same preference granted to West Virginia resident vendors bidding against them in West Virginia. Any request for reciprocal preference must include with the bid any information necessary to evaluate and confirm the applicability of the preference. A request form to help facilitate the request can be found at: <http://www.state.wv.us/admin/purchase/vrc/Venpref.pdf>.

16. SMALL, WOMEN-OWNED, OR MINORITY-OWNED BUSINESSES: For any solicitations publicly advertised for bid, in accordance with West Virginia Code §5A-3-37(a)(7) and W. Va. CSR § 148-22-9, any non-resident vendor certified as a small, women-owned, or minority-owned business under W. Va. CSR § 148-22-9 shall be provided the same preference made available to any resident vendor. Any non-resident small, women-owned, or

minority-owned business must identify itself as such in writing, must submit that writing to the Purchasing Division with its bid, and must be properly certified under W. Va. CSR § 148-22-9 prior to contract award to receive the preferences made available to resident vendors. Preference for a non-resident small, women-owned, or minority owned business shall be applied in accordance with W. Va. CSR § 148-22-9.

17. WAIVER OF MINOR IRREGULARITIES: The Director reserves the right to waive minor irregularities in bids or specifications in accordance with West Virginia Code of State Rules § 148-1-4.6.

18. ELECTRONIC FILE ACCESS RESTRICTIONS: Vendor must ensure that its submission in wvOASIS can be accessed and viewed by the Purchasing Division staff immediately upon bid opening. The Purchasing Division will consider any file that cannot be immediately accessed and viewed at the time of the bid opening (such as, encrypted files, password protected files, or incompatible files) to be blank or incomplete as context requires, and are therefore unacceptable. A vendor will not be permitted to unencrypt files, remove password protections, or resubmit documents after bid opening to make a file viewable if those documents are required with the bid. A Vendor may be required to provide document passwords or remove access restrictions to allow the Purchasing Division to print or electronically save documents provided that those documents are viewable by the Purchasing Division prior to obtaining the password or removing the access restriction.

19. NON-RESPONSIBLE: The Purchasing Division Director reserves the right to reject the bid of any vendor as Non-Responsible in accordance with W. Va. Code of State Rules § 148-1-5.3, when the Director determines that the vendor submitting the bid does not have the capability to fully perform, or lacks the integrity and reliability to assure good-faith performance.”

20. ACCEPTANCE/REJECTION: The State may accept or reject any bid in whole, or in part in accordance with W. Va. Code of State Rules § 148-1-4.5. and § 148-1-6.4.b.”

21. YOUR SUBMISSION IS A PUBLIC DOCUMENT: Vendor’s entire response to the Solicitation and the resulting Contract are public documents. As public documents, they will be disclosed to the public following the bid/proposal opening or award of the contract, as required by the competitive bidding laws of West Virginia Code §§ 5A-3-1 et seq., 5-22-1 et seq., and 5G-1-1 et seq. and the Freedom of Information Act West Virginia Code §§ 29B-1-1 et seq.

DO NOT SUBMIT MATERIAL YOU CONSIDER TO BE CONFIDENTIAL, A TRADE SECRET, OR OTHERWISE NOT SUBJECT TO PUBLIC DISCLOSURE.

Submission of any bid, proposal, or other document to the Purchasing Division constitutes your explicit consent to the subsequent public disclosure of the bid, proposal, or document. The Purchasing Division will disclose any document labeled “confidential,” “proprietary,” “trade secret,” “private,” or labeled with any other claim against public disclosure of the documents, to include any “trade secrets” as defined by West Virginia Code § 47-22-1 et seq. All submissions are subject to public disclosure without notice.

22. INTERESTED PARTY DISCLOSURE: West Virginia Code § 6D-1-2 requires that the vendor submit to the Purchasing Division a disclosure of interested parties to the contract for all contracts with an actual or estimated value of at least \$1 Million. That disclosure must occur on the form prescribed and approved by the WV Ethics Commission prior to contract award. A copy of that form is included with this solicitation or can be obtained from the WV Ethics Commission. This requirement does not apply to publicly traded companies listed on a national or international stock exchange. A more detailed definition of interested parties can be obtained from the form referenced above.

23. WITH THE BID REQUIREMENTS: In instances where these specifications require documentation or other information with the bid, and a vendor fails to provide it with the bid, the Director of the Purchasing Division reserves the right to request those items after bid opening and prior to contract award pursuant to the authority to waive minor irregularities in bids or specifications under W. Va. CSR § 148-1-4.6. This authority does not apply to instances where state law mandates receipt with the bid.

GENERAL TERMS AND CONDITIONS:

1. CONTRACTUAL AGREEMENT: Issuance of a Award Document signed by the Purchasing Division Director, or his designee, and approved as to form by the Attorney General's office constitutes acceptance of this Contract made by and between the State of West Virginia and the Vendor. Vendor's signature on its bid signifies Vendor's agreement to be bound by and accept the terms and conditions contained in this Contract.

2. DEFINITIONS: As used in this Solicitation/Contract, the following terms shall have the meanings attributed to them below. Additional definitions may be found in the specifications included with this Solicitation/Contract.

2.1. "Agency" or "Agencies" means the agency, board, commission, or other entity of the State of West Virginia that is identified on the first page of the Solicitation or any other public entity seeking to procure goods or services under this Contract.

2.2. "Bid" or "Proposal" means the vendors submitted response to this solicitation.

2.3. "Contract" means the binding agreement that is entered into between the State and the Vendor to provide the goods or services requested in the Solicitation.

2.4. "Director" means the Director of the West Virginia Department of Administration, Purchasing Division.

2.5. "Purchasing Division" means the West Virginia Department of Administration, Purchasing Division.

2.6. "Award Document" means the document signed by the Agency and the Purchasing Division, and approved as to form by the Attorney General, that identifies the Vendor as the contract holder.

2.7. "Solicitation" means the official notice of an opportunity to supply the State with goods or services that is published by the Purchasing Division.

2.8. "State" means the State of West Virginia and/or any of its agencies, commissions, boards, etc. as context requires.

2.9. "Vendor" or "Vendors" means any entity submitting a bid in response to the Solicitation, the entity that has been selected as the lowest responsible bidder, or the entity that has been awarded the Contract as context requires.

3. CONTRACT TERM; RENEWAL; EXTENSION: The term of this Contract shall be determined in accordance with the category that has been identified as applicable to this Contract below:

Term Contract

Initial Contract Term: This Contract becomes effective on _____ and extends for a period of _____ year(s).

Renewal Term: This Contract may be renewed upon the mutual written consent of the Agency, and the Vendor, with approval of the Purchasing Division and the Attorney General's office (Attorney General approval is as to form only). Any request for renewal should be delivered to the Agency and then submitted to the Purchasing Division thirty (30) days prior to the expiration date of the initial contract term or appropriate renewal term. A Contract renewal shall be in accordance with the terms and conditions of the original contract. Unless otherwise specified below, renewal of this Contract is limited to _____ successive one (1) year periods or multiple renewal periods of less than one year, provided that the multiple renewal periods do not exceed the total number of months available in all renewal years combined. Automatic renewal of this Contract is prohibited. Renewals must be approved by the Vendor, Agency, Purchasing Division and Attorney General's office (Attorney General approval is as to form only)

Alternate Renewal Term – This contract may be renewed for _____ successive _____ year periods or shorter periods provided that they do not exceed the total number of months contained in all available renewals. Automatic renewal of this Contract is prohibited. Renewals must be approved by the Vendor, Agency, Purchasing Division and Attorney General's office (Attorney General approval is as to form only)

Delivery Order Limitations: In the event that this contract permits delivery orders, a delivery order may only be issued during the time this Contract is in effect. Any delivery order issued within one year of the expiration of this Contract shall be effective for one year from the date the delivery order is issued. No delivery order may be extended beyond one year after this Contract has expired.

Fixed Period Contract: This Contract becomes effective upon Vendor's receipt of the notice to proceed and must be completed within fourteen (14) days.

Fixed Period Contract with Renewals: This Contract becomes effective upon Vendor's receipt of the notice to proceed and part of the Contract more fully described in the attached specifications must be completed within _____ days. Upon completion of the work covered by the preceding sentence, the vendor agrees that maintenance, monitoring, or warranty services will be provided for _____ year(s) thereafter.

One Time Purchase: The term of this Contract shall run from the issuance of the Award Document until all of the goods contracted for have been delivered, but in no event will this Contract extend for more than one fiscal year.

Other: See attached.

4. NOTICE TO PROCEED: Vendor shall begin performance of this Contract immediately upon receiving notice to proceed unless otherwise instructed by the Agency. Unless otherwise specified, the fully executed Award Document will be considered notice to proceed.

5. QUANTITIES: The quantities required under this Contract shall be determined in accordance with the category that has been identified as applicable to this Contract below.

Open End Contract: Quantities listed in this Solicitation are approximations only, based on estimates supplied by the Agency. It is understood and agreed that the Contract shall cover the quantities actually ordered for delivery during the term of the Contract, whether more or less than the quantities shown.

Service: The scope of the service to be provided will be more clearly defined in the specifications included herewith.

Combined Service and Goods: The scope of the service and deliverable goods to be provided will be more clearly defined in the specifications included herewith.

One Time Purchase: This Contract is for the purchase of a set quantity of goods that are identified in the specifications included herewith. Once those items have been delivered, no additional goods may be procured under this Contract without an appropriate change order approved by the Vendor, Agency, Purchasing Division, and Attorney General's office.

6. EMERGENCY PURCHASES: The Purchasing Division Director may authorize the Agency to purchase goods or services in the open market that Vendor would otherwise provide under this Contract if those goods or services are for immediate or expedited delivery in an emergency. Emergencies shall include, but are not limited to, delays in transportation or an unanticipated increase in the volume of work. An emergency purchase in the open market, approved by the Purchasing Division Director, shall not constitute a breach of this Contract and shall not entitle the Vendor to any form of compensation or damages. This provision does not excuse the State from fulfilling its obligations under a One Time Purchase contract.

7. REQUIRED DOCUMENTS: All of the items checked below must be provided to the Purchasing Division by the Vendor as specified below.

BID BOND (Construction Only): Pursuant to the requirements contained in W. Va. Code § 5-22-1(c), All Vendors submitting a bid on a construction project shall furnish a valid bid bond in the amount of five percent (5%) of the total amount of the bid protecting the State of West Virginia. The bid bond must be submitted with the bid.

PERFORMANCE BOND: The apparent successful Vendor shall provide a performance bond in the amount of 100% of the contract. The performance bond must be received by the Purchasing Division prior to Contract award.

LABOR/MATERIAL PAYMENT BOND: The apparent successful Vendor shall provide a labor/material payment bond in the amount of 100% of the Contract value. The labor/material payment bond must be delivered to the Purchasing Division prior to Contract award.

In lieu of the Bid Bond, Performance Bond, and Labor/Material Payment Bond, the Vendor may provide certified checks, cashier's checks, or irrevocable letters of credit. Any certified check, cashier's check, or irrevocable letter of credit provided in lieu of a bond must be of the same amount and delivered on the same schedule as the bond it replaces. A letter of credit submitted in lieu of a performance and labor/material payment bond will only be allowed for projects under \$100,000. Personal or business checks are not acceptable. Notwithstanding the foregoing, West Virginia Code § 5-22-1 (d) mandates that a vendor provide a performance and labor/material payment bond for construction projects. Accordingly, substitutions for the performance and labor/material payment bonds for construction projects is not permitted.

MAINTENANCE BOND: The apparent successful Vendor shall provide a two (2) year maintenance bond covering the roofing system. The maintenance bond must be issued and delivered to the Purchasing Division prior to Contract award.

LICENSE(S) / CERTIFICATIONS / PERMITS: In addition to anything required under the Section of the General Terms and Conditions entitled Licensing, the apparent successful Vendor shall furnish proof of the following licenses, certifications, and/or permits upon request and in a form acceptable to the State. The request may be prior to or after contract award at the State's sole discretion.

The apparent successful Vendor shall also furnish proof of any additional licenses or certifications contained in the specifications regardless of whether or not that requirement is listed above.

8. INSURANCE: The apparent successful Vendor shall furnish proof of the insurance identified by a checkmark below and must include the State as an additional insured on each policy prior to Contract award. The insurance coverages identified below must be maintained throughout the life of this contract. Thirty (30) days prior to the expiration of the insurance policies, Vendor shall provide the Agency with proof that the insurance mandated herein has been continued. Vendor must also provide Agency with immediate notice of any changes in its insurance policies, including but not limited to, policy cancelation, policy reduction, or change in insurers. The apparent successful Vendor shall also furnish proof of any additional insurance requirements contained in the specifications prior to Contract award regardless of whether or not that insurance requirement is listed in this section.

Vendor must maintain:

Commercial General Liability Insurance in at least an amount of: \$1,000,000.00 per occurrence.

Automobile Liability Insurance in at least an amount of: \$1,000,000.00 per occurrence.

Professional/Malpractice/Errors and Omission Insurance in at least an amount of: _____ per occurrence. Notwithstanding the forgoing, Vendor's are not required to list the State as an additional insured for this type of policy.

Commercial Crime and Third Party Fidelity Insurance in an amount of: \$100,000.00 per occurrence.

Cyber Liability Insurance in an amount of: _____ per occurrence.

Builders Risk Insurance in an amount equal to 100% of the amount of the Contract.

Pollution Insurance in an amount of: _____ per occurrence.

Aircraft Liability in an amount of: _____ per occurrence.

Notwithstanding anything contained in this section to the contrary, the Director of the Purchasing Division reserves the right to waive the requirement that the State be named as an additional insured on one or more of the Vendor's insurance policies if the Director finds that doing so is in the State's best interest.

9. WORKERS' COMPENSATION INSURANCE: The apparent successful Vendor shall comply with laws relating to workers compensation, shall maintain workers' compensation insurance when required, and shall furnish proof of workers' compensation insurance upon request.

10. [Reserved]

11. LIQUIDATED DAMAGES: This clause shall in no way be considered exclusive and shall not limit the State or Agency's right to pursue any other available remedy. Vendor shall pay liquidated damages in the amount specified below or as described in the specifications:

\$250.00 per day for failure to complete within contract dates

Liquidated Damages Contained in the Specifications

12. ACCEPTANCE: Vendor's signature on its bid, or on the certification and signature page, constitutes an offer to the State that cannot be unilaterally withdrawn, signifies that the product or service proposed by vendor meets the mandatory requirements contained in the Solicitation for that product or service, unless otherwise indicated, and signifies acceptance of the terms and conditions contained in the Solicitation unless otherwise indicated.

13. PRICING: The pricing set forth herein is firm for the life of the Contract, unless specified elsewhere within this Solicitation/Contract by the State. A Vendor's inclusion of price adjustment provisions in its bid, without an express authorization from the State in the Solicitation to do so, may result in bid disqualification. Notwithstanding the foregoing, Vendor must extend any publicly advertised sale price to the State and invoice at the lower of the contract price or the publicly advertised sale price.

14. PAYMENT IN ARREARS: Payment in advance is prohibited under this Contract. Payment may only be made after the delivery and acceptance of goods or services. The Vendor shall submit invoices, in arrears.

15. PAYMENT METHODS: Vendor must accept payment by electronic funds transfer and P-Card. (The State of West Virginia's Purchasing Card program, administered under contract by a banking institution, processes payment for goods and services through state designated credit cards.)

16. TAXES: The Vendor shall pay any applicable sales, use, personal property or any other taxes arising out of this Contract and the transactions contemplated thereby. The State of West Virginia is exempt from federal and state taxes and will not pay or reimburse such taxes.

17. ADDITIONAL FEES: Vendor is not permitted to charge additional fees or assess additional charges that were not either expressly provided for in the solicitation published by the State of West Virginia or included in the unit price or lump sum bid amount that Vendor is required by the solicitation to provide. Including such fees or charges as notes to the solicitation may result in rejection of vendor's bid. Requesting such fees or charges be paid after the contract has been awarded may result in cancellation of the contract.

18. FUNDING: This Contract shall continue for the term stated herein, contingent upon funds being appropriated by the Legislature or otherwise being made available. In the event funds are not appropriated or otherwise made available, this Contract becomes void and of no effect beginning on July 1 of the fiscal year for which funding has not been appropriated or otherwise made available.

19. CANCELLATION: The Purchasing Division Director reserves the right to cancel this Contract immediately upon written notice to the vendor if the materials or workmanship supplied do not conform to the specifications contained in the Contract. The Purchasing Division Director may also cancel any purchase or Contract upon 30 days written notice to the Vendor in accordance with West Virginia Code of State Rules § 148-1-5.2.b.

20. TIME: Time is of the essence with regard to all matters of time and performance in this Contract.

21. APPLICABLE LAW: This Contract is governed by and interpreted under West Virginia law without giving effect to its choice of law principles. Any information provided in specification manuals, or any other source, verbal or written, which contradicts or violates the West Virginia Constitution, West Virginia Code or West Virginia Code of State Rules is void and of no effect.

22. COMPLIANCE WITH LAWS: Vendor shall comply with all applicable federal, state, and local laws, regulations and ordinances. By submitting a bid, Vendor acknowledges that it has reviewed, understands, and will comply with all applicable laws, regulations, and ordinances.

SUBCONTRACTOR COMPLIANCE: Vendor shall notify all subcontractors providing commodities or services related to this Contract that as subcontractors, they too are required to comply with all applicable laws, regulations, and ordinances. Notification under this provision must occur prior to the performance of any work under the contract by the subcontractor.

23. ARBITRATION: Any references made to arbitration contained in this Contract, Vendor's bid, or in any American Institute of Architects documents pertaining to this Contract are hereby deleted, void, and of no effect.

24. MODIFICATIONS: This writing is the parties' final expression of intent. Notwithstanding anything contained in this Contract to the contrary no modification of this Contract shall be binding without mutual written consent of the Agency, and the Vendor, with approval of the Purchasing Division and the Attorney General's office (Attorney General approval is as to form only). Any change to existing contracts that adds work or changes contract cost, and were not included in the original contract, must be approved by the Purchasing Division and the Attorney General's Office (as to form) prior to the implementation of the change or commencement of work affected by the change.

25. WAIVER: The failure of either party to insist upon a strict performance of any of the terms or provision of this Contract, or to exercise any option, right, or remedy herein contained, shall not be construed as a waiver or a relinquishment for the future of such term, provision, option, right, or remedy, but the same shall continue in full force and effect. Any waiver must be expressly stated in writing and signed by the waiving party.

26. SUBSEQUENT FORMS: The terms and conditions contained in this Contract shall supersede any and all subsequent terms and conditions which may appear on any form documents submitted by Vendor to the Agency or Purchasing Division such as price lists, order forms, invoices, sales agreements, or maintenance agreements, and includes internet websites or other electronic documents. Acceptance or use of Vendor's forms does not constitute acceptance of the terms and conditions contained thereon.

27. ASSIGNMENT: Neither this Contract nor any monies due, or to become due hereunder, may be assigned by the Vendor without the express written consent of the Agency, the Purchasing Division, the Attorney General's office (as to form only), and any other government agency or office that may be required to approve such assignments.

28. WARRANTY: The Vendor expressly warrants that the goods and/or services covered by this Contract will: (a) conform to the specifications, drawings, samples, or other description furnished or specified by the Agency; (b) be merchantable and fit for the purpose intended; and (c) be free from defect in material and workmanship.

29. STATE EMPLOYEES: State employees are not permitted to utilize this Contract for personal use and the Vendor is prohibited from permitting or facilitating the same.

30. PRIVACY, SECURITY, AND CONFIDENTIALITY: The Vendor agrees that it will not disclose to anyone, directly or indirectly, any such personally identifiable information or other confidential information gained from the Agency, unless the individual who is the subject of the information consents to the disclosure in writing or the disclosure is made pursuant to the Agency's policies, procedures, and rules. Vendor further agrees to comply with the Confidentiality Policies and Information Security Accountability Requirements, set forth in <http://www.state.wv.us/admin/purchase/privacy/default.html>.

31. YOUR SUBMISSION IS A PUBLIC DOCUMENT: Vendor's entire response to the Solicitation and the resulting Contract are public documents. As public documents, they will be disclosed to the public following the bid/proposal opening or award of the contract, as required by the competitive bidding laws of West Virginia Code §§ 5A-3-1 et seq., 5-22-1 et seq., and 5G-1-1 et seq. and the Freedom of Information Act West Virginia Code §§ 29B-1-1 et seq.

DO NOT SUBMIT MATERIAL YOU CONSIDER TO BE CONFIDENTIAL, A TRADE SECRET, OR OTHERWISE NOT SUBJECT TO PUBLIC DISCLOSURE.

Submission of any bid, proposal, or other document to the Purchasing Division constitutes your explicit consent to the subsequent public disclosure of the bid, proposal, or document. The Purchasing Division will disclose any document labeled "confidential," "proprietary," "trade secret," "private," or labeled with any other claim against public disclosure of the documents, to include any "trade secrets" as defined by West Virginia Code § 47-22-1 et seq. All submissions are subject to public disclosure without notice.

32. LICENSING: In accordance with West Virginia Code of State Rules § 148-1-6.1.e, Vendor must be licensed and in good standing in accordance with any and all state and local laws and requirements by any state or local agency of West Virginia, including, but not limited to, the West Virginia Secretary of State's Office, the West Virginia Tax Department, West Virginia Insurance Commission, or any other state agency or political subdivision. Obligations related to political subdivisions may include, but are not limited to, business licensing, business and occupation taxes, inspection compliance, permitting, etc. Upon request, the Vendor must provide all necessary releases to obtain information to enable the Purchasing Division Director or the Agency to verify that the Vendor is licensed and in good standing with the above entities.

SUBCONTRACTOR COMPLIANCE: Vendor shall notify all subcontractors providing commodities or services related to this Contract that as subcontractors, they too are required to be licensed, in good standing, and up-to-date on all state and local obligations as described in this section. Obligations related to political subdivisions may include, but are not limited to, business licensing, business and occupation taxes, inspection compliance, permitting, etc. Notification under this provision must occur prior to the performance of any work under the contract by the subcontractor.

33. ANTITRUST: In submitting a bid to, signing a contract with, or accepting a Award Document from any agency of the State of West Virginia, the Vendor agrees to convey, sell, assign, or transfer to the State of West Virginia all rights, title, and interest in and to all causes of action it may now or hereafter acquire under the antitrust laws of the United States and the State of West Virginia for price fixing and/or unreasonable restraints of trade relating to the particular commodities or services purchased or acquired by the State of West Virginia. Such assignment shall be made and become effective at the time the purchasing agency tenders the initial payment to Vendor.

34. VENDOR CERTIFICATIONS: By signing its bid or entering into this Contract, Vendor certifies (1) that its bid or offer was made without prior understanding, agreement, or connection with any corporation, firm, limited liability company, partnership, person or entity submitting a bid or offer for the same material, supplies, equipment or services; (2) that its bid or offer is in all respects fair and without collusion or fraud; (3) that this Contract is accepted or entered into without any prior understanding, agreement, or connection to any other entity that could be considered a violation of law; and (4) that it has reviewed this Solicitation in its entirety; understands the requirements, terms and conditions, and other information contained herein.

Vendor's signature on its bid or offer also affirms that neither it nor its representatives have any interest, nor shall acquire any interest, direct or indirect, which would compromise the performance of its services hereunder. Any such interests shall be promptly presented in detail to the Agency. The individual signing this bid or offer on behalf of Vendor certifies that he or she is authorized by the Vendor to execute this bid or offer or any documents related thereto on Vendor's behalf; that he or she is authorized to bind the Vendor in a contractual relationship; and that, to the best of his or her knowledge, the Vendor has properly registered with any State agency that may require registration.

35. VENDOR RELATIONSHIP: The relationship of the Vendor to the State shall be that of an independent contractor and no principal-agent relationship or employer-employee relationship is contemplated or created by this Contract. The Vendor as an independent contractor is solely liable for the acts and omissions of its employees and agents. Vendor shall be responsible for selecting, supervising, and compensating any and all individuals employed pursuant to the terms of this Solicitation and resulting contract. Neither the Vendor, nor any employees or subcontractors of the Vendor, shall be deemed to be employees of the State for any purpose whatsoever. Vendor shall be exclusively responsible for payment of employees and contractors for all wages and salaries, taxes, withholding payments, penalties, fees, fringe benefits, professional liability insurance premiums, contributions to insurance and pension, or other deferred compensation plans, including but not limited to, Workers' Compensation and Social Security obligations, licensing fees, etc. and the filing of all necessary documents, forms, and returns pertinent to all of the foregoing.

Vendor shall hold harmless the State, and shall provide the State and Agency with a defense against any and all claims including, but not limited to, the foregoing payments, withholdings, contributions, taxes, Social Security taxes, and employer income tax returns.

36. INDEMNIFICATION: The Vendor agrees to indemnify, defend, and hold harmless the State and the Agency, their officers, and employees from and against: (1) Any claims or losses for services rendered by any subcontractor, person, or firm performing or supplying services, materials, or supplies in connection with the performance of the Contract; (2) Any claims or losses resulting to any person or entity injured or damaged by the Vendor, its officers, employees, or subcontractors by the publication, translation, reproduction, delivery, performance, use, or disposition of any data used under the Contract in a manner not authorized by the Contract, or by Federal or State statutes or regulations; and (3) Any failure of the Vendor, its officers, employees, or subcontractors to observe State and Federal laws including, but not limited to, labor and wage and hour laws.

37. PURCHASING AFFIDAVIT: In accordance with West Virginia Code §§ 5A-3-10a and 5-22-1(i), the State is prohibited from awarding a contract to any bidder that owes a debt to the State or a political subdivision of the State, Vendors are required to sign, notarize, and submit the Purchasing Affidavit to the Purchasing Division affirming under oath that it is not in default on any monetary obligation owed to the state or a political subdivision of the state.

38. ADDITIONAL AGENCY AND LOCAL GOVERNMENT USE: This Contract may be utilized by other agencies, spending units, and political subdivisions of the State of West Virginia; county, municipal, and other local government bodies; and school districts ("Other Government Entities"), provided that both the Other Government Entity and the Vendor agree. Any extension of this Contract to the aforementioned Other Government Entities must be on the same prices, terms, and conditions as those offered and agreed to in this Contract, provided that such extension is in compliance with the applicable laws, rules, and ordinances of the Other Government Entity. A refusal to extend this Contract to the Other Government Entities shall not impact or influence the award of this Contract in any manner.

39. CONFLICT OF INTEREST: Vendor, its officers or members or employees, shall not presently have or acquire an interest, direct or indirect, which would conflict with or compromise the performance of its obligations hereunder. Vendor shall periodically inquire of its officers, members and employees to ensure that a conflict of interest does not arise. Any conflict of interest discovered shall be promptly presented in detail to the Agency.

40. REPORTS: Vendor shall provide the Agency and/or the Purchasing Division with the following reports identified by a checked box below:

Such reports as the Agency and/or the Purchasing Division may request. Requested reports may include, but are not limited to, quantities purchased, agencies utilizing the contract, total contract expenditures by agency, etc.

Quarterly reports detailing the total quantity of purchases in units and dollars, along with a listing of purchases by agency. Quarterly reports should be delivered to the Purchasing Division via email at purchasing.requisitions@wv.gov.

41. BACKGROUND CHECK: In accordance with W. Va. Code § 15-2D-3, the Director of the Division of Protective Services shall require any service provider whose employees are regularly employed on the grounds or in the buildings of the Capitol complex or who have access to sensitive or critical information to submit to a fingerprint-based state and federal background inquiry through the state repository. The service provider is responsible for any costs associated with the fingerprint-based state and federal background inquiry.

After the contract for such services has been approved, but before any such employees are permitted to be on the grounds or in the buildings of the Capitol complex or have access to sensitive or critical information, the service provider shall submit a list of all persons who will be physically present and working at the Capitol complex to the Director of the Division of Protective Services for purposes of verifying compliance with this provision. The State reserves the right to prohibit a service provider's employees from accessing sensitive or critical information or to be present at the Capitol complex based upon results addressed from a criminal background check.

Revised 01/09/2020

Service providers should contact the West Virginia Division of Protective Services by phone at (304) 558-9911 for more information.

42. PREFERENCE FOR USE OF DOMESTIC STEEL PRODUCTS: Except when authorized by the Director of the Purchasing Division pursuant to W. Va. Code § 5A-3-56, no contractor may use or supply steel products for a State Contract Project other than those steel products made in the United States. A contractor who uses steel products in violation of this section may be subject to civil penalties pursuant to W. Va. Code § 5A-3-56. As used in this section:

- a. "State Contract Project" means any erection or construction of, or any addition to, alteration of or other improvement to any building or structure, including, but not limited to, roads or highways, or the installation of any heating or cooling or ventilating plants or other equipment, or the supply of and materials for such projects, pursuant to a contract with the State of West Virginia for which bids were solicited on or after June 6, 2001.
- b. "Steel Products" means products rolled, formed, shaped, drawn, extruded, forged, cast, fabricated or otherwise similarly processed, or processed by a combination of two or more or such operations, from steel made by the open heath, basic oxygen, electric furnace, Bessemer or other steel making process. The Purchasing Division Director may, in writing, authorize the use of foreign steel products if:
- c. The cost for each contract item used does not exceed one tenth of one percent (.1%) of the total contract cost or two thousand five hundred dollars (\$2,500.00), whichever is greater. For the purposes of this section, the cost is the value of the steel product as delivered to the project; or
- d. The Director of the Purchasing Division determines that specified steel materials are not produced in the United States in sufficient quantity or otherwise are not reasonably available to meet contract requirements.

43. PREFERENCE FOR USE OF DOMESTIC ALUMINUM, GLASS, AND STEEL: In Accordance with W. Va. Code § 5-19-1 et seq., and W. Va. CSR § 148-10-1 et seq., for every contract or subcontract, subject to the limitations contained herein, for the construction, reconstruction, alteration, repair, improvement or maintenance of public works or for the purchase of any item of machinery or equipment to be used at sites of public works, only domestic aluminum, glass or steel products shall be supplied unless the spending officer determines, in writing, after the receipt of offers or bids, (1) that the cost of domestic aluminum, glass or steel products is unreasonable or inconsistent with the public interest of the State of West Virginia, (2) that domestic aluminum, glass or steel products are not produced in sufficient quantities to meet the contract requirements, or (3) the available domestic aluminum, glass, or steel do not meet the contract specifications. This provision only applies to public works contracts awarded in an amount more than fifty thousand dollars (\$50,000) or public works contracts that require more than ten thousand pounds of steel products.

The cost of domestic aluminum, glass, or steel products may be unreasonable if the cost is more than twenty percent (20%) of the bid or offered price for foreign made aluminum, glass, or steel products. If the domestic aluminum, glass or steel products to be supplied or produced in a

“substantial labor surplus area”, as defined by the United States Department of Labor, the cost of domestic aluminum, glass, or steel products may be unreasonable if the cost is more than thirty percent (30%) of the bid or offered price for foreign made aluminum, glass, or steel products. This preference shall be applied to an item of machinery or equipment, as indicated above, when the item is a single unit of equipment or machinery manufactured primarily of aluminum, glass or steel, is part of a public works contract and has the sole purpose or of being a permanent part of a single public works project. This provision does not apply to equipment or machinery purchased by a spending unit for use by that spending unit and not as part of a single public works project.

All bids and offers including domestic aluminum, glass or steel products that exceed bid or offer prices including foreign aluminum, glass or steel products after application of the preferences provided in this provision may be reduced to a price equal to or lower than the lowest bid or offer price for foreign aluminum, glass or steel products plus the applicable preference. If the reduced bid or offer prices are made in writing and supersede the prior bid or offer prices, all bids or offers, including the reduced bid or offer prices, will be reevaluated in accordance with this rule.

44. INTERESTED PARTY SUPPLEMENTAL DISCLOSURE: W. Va. Code § 6D-1-2 requires that for contracts with an actual or estimated value of at least \$1 million, the vendor must submit to the Agency a supplemental disclosure of interested parties reflecting any new or differing interested parties to the contract, which were not included in the original pre-award interested party disclosure, within 30 days following the completion or termination of the contract. A copy of that form is included with this solicitation or can be obtained from the WV Ethics Commission. This requirement does not apply to publicly traded companies listed on a national or international stock exchange. A more detailed definition of interested parties can be obtained from the form referenced above.

45. PROHIBITION AGAINST USED OR REFURBISHED: Unless expressly permitted in the solicitation published by the State, Vendor must provide new, unused commodities, and is prohibited from supplying used or refurbished commodities, in fulfilling its responsibilities under this Contract.

ADDITIONAL TERMS AND CONDITIONS (Construction Contracts Only)

1. CONTRACTOR'S LICENSE: West Virginia Code § 21-11-2 requires that all persons desiring to perform contracting work in this state be licensed. The West Virginia Contractors Licensing Board is empowered to issue the contractor's license. Applications for a contractor's license may be made by contacting the West Virginia Division of Labor. West Virginia Code § 21-11-11 requires any prospective Vendor to include the contractor's license number on its bid. If an apparent low bidder fails to submit a license number in accordance with this section, the Purchasing Division will promptly request by telephone and electronic mail that the low bidder and the second low bidder provide the license number within one business day of the request. Failure of the bidder to provide the license number within one business day of receiving the request shall result in disqualification of the bid. Vendors should include a contractor's license number in the space provided below.

Contractor's Name: Grae-Con Construction, Inc.
Contractor's License No.: WV- WV001293

The apparent successful Vendor must furnish a copy of its contractor's license prior to the issuance of a contract award document.

2. DRUG-FREE WORKPLACE AFFIDAVIT: W. Va. Code § 21-1D-5 provides that any solicitation for a public improvement contract requires each Vendor that submits a bid for the work to submit an affidavit that the Vendor has a written plan for a drug-free workplace policy. If the affidavit is not submitted with the bid submission, the Purchasing Division shall promptly request by telephone and electronic mail that the low bidder and second low bidder provide the affidavit within one business day of the request. Failure to submit the affidavit within one business day of receiving the request shall result in disqualification of the bid. To comply with this law, Vendor should complete the enclosed drug-free workplace affidavit and submit the same with its bid. Failure to submit the signed and notarized drugfree workplace affidavit or a similar affidavit that fully complies with the requirements of the applicable code, within one business day of being requested to do so shall result in disqualification of Vendor's bid. Pursuant to W. Va. Code 21-1D-2(b) and (k), this provision does not apply to public improvement contracts the value of which is \$100,000 or less or temporary or emergency repairs.

2.1. DRUG-FREE WORKPLACE POLICY: Pursuant to W. Va. Code § 21-1D-4, Vendor and its subcontractors must implement and maintain a written drug-free workplace policy that complies with said article. The awarding public authority shall cancel this contract if: (1) Vendor fails to implement and maintain a written drug-free workplace policy described in the preceding paragraph, (2) Vendor fails to provide information regarding implementation of its drug-free workplace policy at the request of the public authority; or (3) Vendor provides to the public authority false information regarding the contractor's drug-free workplace policy.

Pursuant to W. Va. Code 21-1D-2(b) and (k), this provision does not apply to public improvement contracts the value of which is \$100,000 or less or temporary or emergency repairs.

3. DRUG FREE WORKPLACE REPORT: Pursuant to W. Va. Code § 21-1D-7b, no less than once per year, or upon completion of the project, every contractor shall provide a certified report to the public authority which let the contract. For contracts over \$25,000, the public authority shall be the West Virginia Purchasing Division. For contracts of \$25,000 or less, the public authority shall be the agency issuing the contract. The report shall include:

- (1) Information to show that the education and training service to the requirements of West Virginia Code § 21-1D-5 was provided;
- (2) The name of the laboratory certified by the United States Department of Health and Human Services or its successor that performs the drug tests;
- (3) The average number of employees in connection with the construction on the public improvement;
- (4) Drug test results for the following categories including the number of positive tests and the number of negative tests: (A) Pre-employment and new hires; (B) Reasonable suspicion; (C) Post-accident; and (D) Random.

Vendor should utilize the attached Certified Drug Free Workplace Report Coversheet when submitting the report required hereunder. Pursuant to W. Va. Code 21-1D-2(b) and (k), this provision does not apply to public improvement contracts the value of which is \$100,000 or less or temporary or emergency repairs.

4. AIA DOCUMENTS: All construction contracts that will be completed in conjunction with architectural services procured under Chapter 5G of the West Virginia Code will be governed by the attached AIA documents, as amended by the Supplementary Conditions for the State of West Virginia, in addition to the terms and conditions contained herein.

4A. PROHIBITION AGAINST GENERAL CONDITIONS: Notwithstanding anything contained in the AIA Documents or the Supplementary Conditions, the State of West Virginia will not pay for general conditions, or winter conditions, or any other condition representing a delay in the contracts. The Vendor is expected to mitigate delay costs to the greatest extent possible and any costs associated with Delays must be specifically and concretely identified. The state will not consider an average daily rate multiplied by the number of days extended to be an acceptable charge.

5. GREEN BUILDINGS MINIMUM ENERGY STANDARDS: In accordance with § 22-29-4, all new building construction projects of public agencies that have not entered the schematic design phase prior to July 1, 2012, or any building construction project receiving state grant funds and appropriations, including public schools, that have not entered the schematic design phase prior to July 1, 2012, shall be designed and constructed complying with the ICC International Energy Conservation Code, adopted by the State Fire Commission, and the ANSI/ASHRAE/IESNA Standard 90.1-2007: Provided, That if any construction project has a commitment of federal funds to pay for a portion of such project, this provision shall only apply to the extent such standards are consistent with the federal standards.

6. LOCAL LABOR MARKET HIRING REQUIREMENT: Pursuant to West Virginia Code §21-1C-1 et seq., Employers shall hire at least seventy-five percent of employees for public improvement construction projects from the local labor market, to be rounded off, with at least two employees from outside the local labor market permissible for each employer per project.

Any employer unable to employ the minimum number of employees from the local labor market shall inform the nearest office of Workforce West Virginia of the number of qualified employees needed and provide a job description of the positions to be filled.

If, within three business days following the placing of a job order, Workforce West Virginia is unable to refer any qualified job applicants to the employer or refers less qualified job applicants than the number requested, then Workforce West Virginia shall issue a waiver to the employer stating the unavailability of applicant and shall permit the employer to fill any positions covered by the waiver from outside the local labor market. The waiver shall be in writing and shall be issued within the prescribed three days. A waiver certificate shall be sent to both the employer for its permanent project records and to the public authority.

Any employer who violates this requirement is subject to a civil penalty of \$250 per each employee less than the required threshold of seventy-five percent per day of violation after receipt of a notice of violation.

Any employer that continues to violate any provision of this article more than fourteen calendar days after receipt of a notice of violation is subject to a civil penalty of \$500 per each employee less than the required threshold of seventy-five percent per day of violation.

The following terms used in this section have the meaning shown below.

(1) The term “construction project” means any construction, reconstruction, improvement, enlargement, painting, decorating or repair of any public improvement let to contract in an amount equal to or greater than \$500,000. The term “construction project” does not include temporary or emergency repairs;

(2) The term “employee” means any person hired or permitted to perform hourly work for wages by a person, firm or corporation in the construction industry; The term “employee” does not include:(i) Bona fide employees of a public authority or individuals engaged in making temporary or emergency repairs;(ii) Bona fide independent contractors; or(iii) Salaried supervisory personnel necessary to assure efficient execution of the employee's work;

(3) The term “employer” means any person, firm or corporation employing one or more employees on any public improvement and includes all contractors and subcontractors;

(4) The term “local labor market” means every county in West Virginia and any county outside of West Virginia if any portion of that county is within fifty miles of the border of West Virginia;

(5) The term “public improvement” includes the construction of all buildings, roads, highways, bridges, streets, alleys, sewers, ditches, sewage disposal plants, waterworks, airports and all other structures that may be let to contract by a public authority, excluding improvements funded, in whole or in part, by federal funds.

7. DAVIS-BACON AND RELATED ACT WAGE RATES:

- The work performed under this contract is federally funded in whole, or in part. Pursuant to _____, Vendors are required to pay applicable Davis-Bacon wage rates.
- The work performed under this contract is not subject to Davis-Bacon wage rates.

8. SUBCONTRACTOR LIST SUBMISSION: In accordance with W. Va. Code § 5-22-1, the apparent low bidder on a contract valued at more than \$250,000.00 for the construction, alteration, decoration, painting or improvement of a new or existing building or structure shall submit a list of all subcontractors who will perform more than \$25,000.00 of work on the project including labor and materials. (This section does not apply to any other construction projects, such as highway, mine reclamation, water or sewer projects.) The subcontractor list shall be provided to the Purchasing Division within one business day of the opening of bids for review. If the apparent low bidder fails to submit the subcontractor list, the Purchasing Division shall promptly request by telephone and electronic mail that the low bidder and second low bidder provide the subcontractor list within one business day of the request. Failure to submit the subcontractor list within one business day of receiving the request shall result in disqualification of the bid.

If no subcontractors who will perform more than \$25,000.00 of work are to be used to complete the project, the apparent low bidder must make this clear on the subcontractor list, in the bid itself, or in response to the Purchasing Division's request for the subcontractor list.

a. Required Information. The subcontractor list must contain the following information:

- i. Bidder's name
- ii. Name of each subcontractor performing more than \$25,000 of work on the project.
- iii. The license number of each subcontractor, as required by W. Va. Code § 21-11-1 et. seq.
- iv. If applicable, a notation that no subcontractor will be used to perform more than \$25,000.00 of work. (This item iv. is not required if the vendor makes this clear in the bid itself or in documentation following the request for the subcontractor list.)

b. Subcontractor List Submission Form: The subcontractor list may be submitted in any form, including the attached form, as long as the required information noted above is included. If any information is missing from the bidder's subcontractor list submission, it may be obtained from other documents such as bids, emails, letters, etc. that accompany the subcontractor list submission.

c. Substitution of Subcontractor. Written approval must be obtained from the State Spending Unit before any subcontractor substitution is permitted. Substitutions are not permitted unless:

i. The subcontractor listed in the original bid has filed for bankruptcy;

ii. The subcontractor in the original bid has been debarred or suspended; or

iii. The contractor certifies in writing that the subcontractor listed in the original bid fails, is unable, or refuses to perform his subcontract.

Subcontractor List Submission (Construction Contracts Only)

Bidder's Name: Grae-Con Construction, Inc.

Check this box if no subcontractors will perform more than \$25,000.00 of work to complete the project.

Subcontractor Name	License Number if Required by W. Va. Code § 21-11-1 et. seq.
Thermal Solutions	WV030824

Attach additional pages if necessary

DESIGNATED CONTACT: Vendor appoints the individual identified in this Section as the Contract Administrator and the initial point of contact for matters relating to this Contract.



(Name, Title)
Kevin Kloska, Project Manager/Estimator

(Printed Name and Title)
880 Kingsdale Road - PO Box 1778, Steubenville, OH 43952

(Address)
(740)282-6830, Ext. 1213 Fax: (740)282-6849

(Phone Number) / (Fax Number)
kkloska@graecon.com

(email address)

CERTIFICATION AND SIGNATURE: By signing below, or submitting documentation through wvOASIS, I certify that I have reviewed this Solicitation in its entirety; that I understand the requirements, terms and conditions, and other information contained herein; that this bid, offer or proposal constitutes an offer to the State that cannot be unilaterally withdrawn; that the product or service proposed meets the mandatory requirements contained in the Solicitation for that product or service, unless otherwise stated herein; that the Vendor accepts the terms and conditions contained in the Solicitation, unless otherwise stated herein; that I am submitting this bid, offer or proposal for review and consideration; that I am authorized by the vendor to execute and submit this bid, offer, or proposal, or any documents related thereto on vendor's behalf; that I am authorized to bind the vendor in a contractual relationship; and that to the best of my knowledge, the vendor has properly registered with any State agency that may require registration.

Grae-Con Construction, Inc.

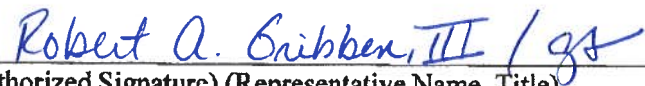
(Company)

(Authorized Signature) (Representative Name, Title)
Robert A. Gribben, III - Vice President

(Printed Name and Title of Authorized Representative)
September 21, 2020

(Date)
(740)282-6830 Fax: (740)282-6849

(Phone Number) (Fax Number)

REQUEST FOR QUOTATION
Water Pump/Motor Skid Replacement – Building 11

GENERAL CONSTRUCTION SPECIFICATIONS (No AIA Documents)

1. **PURPOSE AND SCOPE:** The West Virginia Purchasing Division is soliciting bids on behalf of the WV Department of Administration, General Services Division to establish a contract for the following:

Installation of one (1) Water Pump/Motor Skid replacement.

The Vendor shall furnish all materials, labor, and equipment necessary to complete all Construction Services. The Vendor shall furnish any incidental work, materials, labor, and equipment that are necessary to complete the Construction Services, even if such incidental work is not explicitly included in the Project Plans.

2. **DEFINITIONS:** The terms listed below shall have the meanings assigned to them below. Additional definitions can be found in section 2 of the General Terms and Conditions and in the Project Plans as defined below.

- 2.1 **“Construction Services”** means installation of new water pump/motor skid as more fully described in the Project Plans.

- 2.2 **“Pricing Page”** means the pages contained in wvOASIS, attached hereto as Exhibit A, or included in the Project Plans upon which Vendor should list its proposed price for the Construction Services.

- 2.3 **“Project Plans”** means documents developed by an architect, an engineer, the Agency, or another design professional, which are attached hereto as Exhibit B, that provide detailed instructions on how the Construction Services are to be performed. In the event that Project Plans contain drawings or other documents too large to attach in Exhibit B, Vendors can obtain copies in accordance with Section 9 of these Specifications.

- 2.4 **“Solicitation”** means the official notice of an opportunity to supply the State with Construction Services that is published by the Purchasing Division.

3. **ORDER OF PRECEDENCE:** This General Construction Specifications document will have priority over, and supersede, anything contained in the Project Plans.

4. **QUALIFICATIONS:** Vendor, or Vendor’s staff if requirements are inherently limited to individuals rather than corporate entities, shall have the following minimum qualifications:

- 4.1. **Experience:** Vendor, or Vendor’s supervisory staff assigned to this project, must have successfully completed at least three (3) projects that involved work similar to that described in these specifications or the Project Plans. Compliance with this experience requirement will be determined prior to contract award by the State through references provided by the Vendor upon request, through knowledge or documentation of the

REQUEST FOR QUOTATION
Water Pump/Motor Skid Replacement – Building 11

Vendor's past projects, through confirmation of experience requirements from the architect assisting the State in this project, or some other method that the State determines to be acceptable. Vendor must provide any documentation requested by the State to assist in confirmation of compliance with this provision. References, documentation, or other information to confirm compliance with this experience requirement may be requested after bid opening and prior to contract award.

5. **CONTRACT AWARD:** The Contract is intended to provide Agency with a purchase price for the Construction Services. The Contract will be awarded to the lowest qualified responsible bidder meeting the required specifications. If the Pricing Pages contain alternates/add-ons, the Contract will be awarded based on the grand total of the base bid and any alternates/add-ons selected.
6. **SELECTION OF ALTERNATES:** Pursuant to W. Va. Code § 5-22-1(f), any solicitation of bids shall include no more than five alternates. Alternates, if accepted, shall be accepted in the order in which they are listed on the bid form. Any unaccepted alternate contained within a bid shall expire 90 days after the date of the opening of bids for review. Determination of the lowest qualified responsible bidder shall be based on the sum of the base bid and any alternates accepted.
7. **PERFORMANCE:** Vendor shall perform the Construction Services in accordance with this document and the Project Plans.
8. **SUBSTITUTIONS:** Any substitution requests must be submitted in accordance with the official question and answer period described in the INSTRUCTIONS TO VENDORS SUBMITTING BIDS, Paragraph 4. Vendor Question Deadline. Vendors submitting substitution requests should submit product brochures and product specifications during the official question and answer period.
9. **PROJECT PLANS:** The checked box will apply to Project Plans for this solicitation.

No Additional Project Plan Documents: There are no additional Project Plans other than those attached hereto as Exhibit B or any subsequent addenda modifying Exhibit B.

Additional Project Plan Documents: There are additional Project Plan documents other than those attached as Exhibit B. Copies of the additional Project Plan documents not attached as Exhibit B can be obtained by contacting the entity identified below.

10. CONDITIONS OF THE WORK

10.1. Permits: The Vendor shall procure all necessary permits and licenses to comply with all applicable Federal, State, or Local laws, regulations and ordinances of any regulating body.

REQUEST FOR QUOTATION
Water Pump/Motor Skid Replacement – Building 11

10.2. Existing Conditions: If discrepancies are discovered between the existing conditions and those noted in the specifications, Vendor must immediately notify the Agency's representative. Vendor must also immediately notify the Agency if suspected hazardous materials are encountered.

10.3. Standard Work Hours: The standard hours of work for this Contract will be 7:00am to 5:00pm Monday through Friday excluding holidays recognized by the State of West Virginia. Any work outside of the standard hours of work must be approved in advance at the Agency's sole discretion. Authorization of work outside of the standard hours of work will not entitle Vendor to additional compensation.

10.4. Project Closeout: Project Closeout shall include the following:

10.4.1. Final Cleanup: Vendor shall perform the final cleanup activities listed below, along with any other final cleanup activities normally associated with the work performed under this Contract, prior to final inspection:

10.4.1.1. No additional Final Cleanup activities other than those included in Exhibits B.

10.4.2. Final Inspection: Vendor shall participate in a final inspection with the Agency's project manager. The purpose of the final inspection will be to identify deficiencies that need to be remedied prior to Agency's final acceptance of the work. Vendor shall at all times be obligated to perform in accordance with the Contract and must take all actions necessary to ensure that work complies with requirements of Contract prior to final acceptance. Final acceptance does not waive or release Vendor from its obligation to ensure that work complies with the Contract requirements. Vendor shall submit any warranty documents to the Agency project manager at final inspection.

10.5. Payment:

10.5.1. Agency shall pay flat fee as shown on the Pricing Pages, for all Contract Services performed and accepted under this Contract. Vendor shall accept payment in accordance with the payment procedures of the State of West Virginia.

10.5.2. Invoices shall be submitted for payment (in arrears) and must include the following information:

10.5.2.1. Invoice must include, at a minimum, invoice date, FEIN number, complete address of vendor and Contract number.

REQUEST FOR QUOTATION
Water Pump/Motor Skid Replacement – Building 11

10.5.2.2. Invoices shall be mailed to the following address:

General Services Division
112 California Avenue, 5th Floor
Charleston, WV 25305

10.5.2.3. Or, emailed to GSDInvoices@wv.gov

11. FACILITIES ACCESS: Performance of Contract Services may require access cards and/or keys to gain entrance to Agency's facilities. In the event that access cards and/or keys are required:

11.1. Vendor must identify principal service personnel which will be issued access cards and/or keys to perform service.

11.2. Vendor will be responsible for controlling cards and keys and will pay replacement fee, if the cards or keys become lost or stolen.

11.3. Vendor shall notify Agency immediately of any lost, stolen, or missing card or key.

11.4. Anyone performing under this Contract will be subject to Agency's security protocol and procedures.

11.5. Vendor shall inform all staff of Agency's security protocol and procedures.

12. MISCELLANEOUS:

12.1. Contract Manager: During its performance of this Contract, Vendor must designate and maintain a primary contract manager responsible for overseeing Vendor's responsibilities under this Contract. The Contract manager must be available during normal business hours to address any customer service or other issues related to this Contract. Vendor should list its Contract manager and his or her contact information below.

Contract Manager: Kevin Kloska

Telephone Number: (740)282-6830, Extension 1213

Fax Number: (740)282-6849

Email Address: kkloska@graecon.com

REQUEST FOR QUOTATION
Water Pump/Motor Skid Replacement – Building 11

EXHIBIT A – Pricing Page

Lump Sum Price: to include all labor and materials to replace one (1) Water Pump/Motor Skid.

Lump Sum = \$ 67,000.00

REQUEST FOR QUOTATION
Water Pump/Motor Skid Replacement – Building 11

EXHIBIT B – PROJECT PLANS

1. GENERAL REQUIREMENTS/SPECIFICATIONS

1.1. Vendor shall provide all materials needed to replace one (1) Water Pump/Motor Skid. The existing Unit is a Bell and Gossett VSC Series. 120ft. head, 175psi max. working pressure. 1750 rpm, 125hp, 3ph, 280GPM, 480-volt motor. Pump motors are controlled by AB VFD drives and must be compatible. Scope of work to include removal of complete pump skid, install new assembly. This includes all necessary removal and reinstallation of insulation. Vendor must perform start up and system check to ensure proper operation.

2. PERFORMANCE: Vendor and Agency shall agree upon a schedule for performance of Contract Services and Contract Services Deliverables, unless such a schedule is already included herein by Agency. In the event that this Contract is designated as an open-end contract, Vendor shall perform in accordance with the release orders that may be issued against this Contract.

2.1. Vendor and Agency shall agree upon a schedule for performance of Contract Services and Contract Services Deliverables, unless such a schedule is already included herein by Agency.

2.2. The Vendor shall provide the Agency Project Manager with an overall project schedule within seventy-two (72) hours of Award of the Contract. The proposed project schedule shall indicate areas to be worked. Where coordination or disruption of adjacent workspaces or occupants may be required, provide at least one week's advance notice prior to conducting work in those areas. Vendor shall adhere to schedule provided and coordinate through the Agency Project Manager.

2.3. Work shall be conducted as a single project. The work schedule shall be reviewed and approved by the Agency Project Manager prior to commencement of the work. The Vendor shall coordinate the schedule around the Agency's work requirements

3. TRAVEL: Vendor shall be responsible for all mileage and travel costs, including travel time, associated with performance of this Contract. Any anticipated mileage or travel costs may be included in the Vendor's bid, but such costs will not be paid by the Agency separately.

REQUEST FOR QUOTATION
Water Pump/Motor Skid Replacement – Building 11

4. PROJECT SPECIFIC CONDITIONS OF THE WORK

4.1.Limits of Work

4.1.1. Work areas will be limited to those spaces required for access to the jobsite. The tenant State Agencies or Agency will be responsible for clearing work areas of furniture and property prior to work commencement per the work schedule.

4.1.2. Some interior space may be utilized for temporary (overnight) storage of equipment and tools. Coordinate storage needs with the Agency Project Manager.

Agency facilities shall remain in use during this contract. Contractor shall work with the Building Manager to coordinate the temporary access to work areas and otherwise provide for the Contractor needs to complete work. Contractor shall minimize disruption to building work areas and loading dock access.

Contractor shall be permitted reasonable use of building utilities including power, water and sanitary sewage disposal as required for conducting the work. Contractor shall coordinate the location of service connections or use of receptacles with the Building Manager to avoid overloading existing circuits.

4.1.3. Contractor Visitor Badges

Contractor shall provide a list of all personnel working on this project within the Building. This list shall include a copy of a valid driver's license or other legal identification and include date of birth and cell phone number. Workers shall carry valid Contractor Photo ID Badges to be worn when working in the building. Under no circumstances shall a worker be assigned to this project without the validation first being submitted to the General Services Division and approval given.

4.1.4. Work Restrictions

Access to the building shall be coordinated with the Owner. Contractor shall not leave open doors unattended and shall close doors when not in use.

This is a non-smoking building. Smoking is not permitted within the building or

REQUEST FOR QUOTATION
Water Pump/Motor Skid Replacement – Building 11

near entrances, operable windows or outdoor air intakes.

4.1.5. Parking

Some parking is available on the project site. Parking in non-designated areas is not permitted. Parking is the responsibility of the contractor. With prior approval, contractor's vehicles may be brought on-site for loading & unloading or to provide equipment necessary for conducting the work.

Use of loading dock areas or sidewalk areas for parking is strictly prohibited.

Vendor must coordinate with the Agency on how best to minimize disruption of employee parking during the execution of the work.

4.1.6. Code

All work is to be performed in compliance with applicable Federal and State codes including but not limited to the International Building Code, International Mechanical Code, Life Safety Code, NEC, OSHA, UL, ANSI, ASME and related standards.

4.1.7. Safety

All applicable local safety and OSHA rules and guidelines shall be met by the Contractor. Work shall be subject to verification and inspection by GSD Safety representatives. Such verification shall not relieve the Contractor from meeting all applicable safety regulations and inspection by other agencies.

4.1.8. Hot Work Permit

Contractor shall obtain Owner's permission prior to performing any work that requires an open flame, creates sparks, use's equipment that creates combustible temperatures, or performs any work that could result in a fire hazard. Owner will review work area and issue a 'Hot Work Permit' prior to Contractor commencing work. Note that the Contractor must take proper precautions and may be required to provide a Fire Watch as a condition of the permit.

REQUEST FOR QUOTATION
Water Pump/Motor Skid Replacement – Building 11

4.1.9. Workmanship

Contractor shall complete all work in a neat and workmanlike manner. All work shall be done using new materials in a manner that meets commercial quality standards. Work shall be neat, true, plumb and square, as applicable. Contractor shall verify all dimensions.

4.1.10. General Services Division Jobsite Safety Handbook

Prior to beginning any work covered by the Contract, Vendor shall have read, reviewed and acknowledged in writing the attached Jobsite Safety Handbook (Exhibit C)

4.1.11. Warranty

A one-year warranty on labor is required.

Jobsite Safety Handbook

For Contractors

Department of Administration (DOA)

General Services Division (GSD)

112 California Avenue
Building Four, 5th Floor
Charleston, WV

**THIS HANDBOOK IS TO BE POSTED IN A VISIBLE AREA AT ALL CONSTRUCTION
PROJECTS AND/OR CONTRACTOR WORKSITES**

Contractor Contact: Dan Barton Phone #: (740)282-6830, Ext. 1218
Corporate Safety Director

EMERGENCY CONTACTS:

Project Manager:

Name: Kevin Kloska Phone #: (740)282-6830, Ext. 1213

Emergency Services #: (740)282-6830

GSD Safety Section:

112 California Ave, Bldg.4 5th Floor. Charleston, WV 25305

Jonathan Trout: Work# 304 957-7153 Cell# 304-205-2721

Marsha Bowling Work# 304-957-7154 Cell# 304-951-1410

Revision 2/6/19

TABLE OF CONTENTS

Jobsite Safety Handbook

1. Building Alarms	2
2. Personal Protective Equipment	2
3. Housekeeping and Access Around Site	2
4. Stairs and Ladders	2
5. Scaffolds and Other Work Platforms	3
6. Fall Protection	3
7. Excavation and Trenching	4
8. Tools and Equipment	5
9. Vehicles and Mobile Equipment.....	5
10. Electrical	5
11. Fire Prevention	5
12. Chemical Hazards	6
13. Confined Spaces	6
14. Lock-Out/Tag-Out	6
15. Contractor Acknowledgement	7

JOBSITE SAFETY HANDBOOK

The following is a summary of applicable jobsite safety requirements. This handbook is intended to be used as a guide and in no way reflects all applicable safety requirements. All employees are responsible for ensuring a safe working environment. All hazards must be addressed regardless if they have been addressed in this handbook. All contractors working on GSD projects are required to follow OSHA regulations.

GSD safety and health procedures are available for review 24/7 in the Main Capitol Building basement, MB-69.

1. BUILDING ALARMS

In the event of a fire, sound the alarm and/or notify other building occupants immediately. Contractor personnel shall respond appropriately to all alarms by exiting the building immediately and remaining at least 50 feet from the building to allow for emergency response access.

2. PERSONAL PROTECTIVE EQUIPMENT (PPE)

Workers must use personal protective equipment, such as:

- Hard hats when overhead, falling or flying hazards exist;
- Safety glasses or face shields for welding, cutting, nailing (including pneumatic), or when working with concrete and/or harmful chemicals;
- Proper shoes or boots to lessen slipping hazards and prevent toe crushing and nail punctures;
- Safety belts and/or harness systems for fall protection.

3. HOUSEKEEPING AND ACCESS AROUND SITE

- Keep all walkways and stairways clear of trash/debris and other materials such as tools and supplies to prevent tripping.
- Keep boxes, scrap lumber and other materials picked up and put in a dumpster or trash/debris area to prevent fire and tripping hazards.
- Provide enough light to allow workers to see and to prevent accidents.

4. STAIRS AND LADDERS

- All stairs are to be equipped with standard handrails.
- Keep ladders in good condition and free of defects – Do not use job made ladders.
- Inspect ladders before use for broken rungs or other defects so falls don't happen. Discard defective ladders.
- Secure ladders at the top and brace or tie off at the bottom to prevent them from slipping and causing falls.

5. SCAFFOLDS AND OTHER WORK PLATFORMS

Scaffolding is to be assembled and used according to OSHA regulations.

General scaffolding guidance:

- Provide ladders or stairs to access scaffold and work platforms safely.
- Keep scaffolds and work platforms free of debris. Keep tools and materials as neat as possible on scaffolds and platforms. This will help prevent materials from falling and workers from tripping.
- Erect scaffolds on firm and level foundations.
- Scaffold legs must be placed on firm footing and secured from movement or tipping, especially on dirt or similar surfaces (a good foundation is a must).
- Erecting and dismantling scaffolds must be under the supervision of a Competent Person.
- The competent person must inspect scaffolds before each use.
- Don't use blocks, bricks, or pieces of lumber to level or stabilize the footings. Manufactured base plates or "mud sills" made of hardwood or equivalent can be used.

Planking:

- Fully plank or use manufactured decking to provide a full work platform on scaffolds. The platform decking and/or scaffold planks must be scaffold grade and not have any visible defects.
- Extend planks or decking material at least 6' over the edge or cleat them to prevent movement. The work platform or planks must not extend more than 12" beyond the end supports to prevent tipping when stepping or working.
- Be sure that manufactured scaffolds are the proper size and that the end hooks are attached to the scaffold frame.

Guardrails:

- Guard scaffold platforms that are more than 10 feet above the ground or floor surface must have a standard guardrail. If guardrails are not practical, use other fall protection devices such as safety belts/harnesses and lanyards.
- Place the top rail approximately 42" above the work platform or planking, with a mid-rail about half that high at 21".
- Install toe boards when other workers are below the scaffold.

6. FALL PROTECTION

OSHA has specific and detailed requirements for fall protection – refer to 29 CFR 1926 Subpart M, 29 CFR 1910, 29 CFR Subpart I. A few of those requirements are listed below:

Guarding:

- Install guardrails around open floors and walls when the fall distance is 4' or more. The top rail must withstand a 200 lb load.
- Construct guardrails with a top rail approximately 42" high with a midrail about half that high at 21".
- Install toe boards when other workers are below the work area.
- Cover floor openings larger than 2x2 (inches) with material to safely support the working load.
- Use other fall protection systems like personal fall arrest systems (harness & lanyard), slide guards, roof anchors or alternative safe work practices when a guardrail system cannot be used. Only wear proper shoes or footwear to lessen slipping hazards.
- Train workers on safe work practices before performing work on foundation walls, roofs, trusses, or where performing exterior wall erections and floor installations.
- Flagging systems can be used, where appropriate. Flagging systems must comply with OSHA guidance.

7. EXCAVATION AND TRENCHING

Refer to OSHA regulations for excavation and trenching requirements, along with regulations for walking and working surfaces: 29 CFR 1926 Subpart P, 29 CFR 1910 Subpart D

Some of the Excavation and Trenching requirements are listed below:

- Find the location of all underground utilities by contacting West Virginia 811 before digging. Dial 811 or 800-245-4848.
- Keep workers away from digging equipment and never allow workers in an excavation when equipment is in use.
- Keep workers from getting between equipment in use and other obstacles and machinery that can cause crushing hazards.
- Keep equipment and the excavated dirt back 2 feet from the edge of the excavation.
- Have a competent person conduct daily inspections and correct any hazards before workers enter a trench or excavation.
- Provide workers a way to get into and out of a trench or excavation. Ladders and ramps can be used and must be within 25' of the worker.
- For excavations and utility trenches over 5 feet deep, use shoring (trench boxes), benching, or slope back the sides. Unless soil analysis has been completed, the earth's slope must be at least 1-1/2 horizontal to 1 vertical
- Keep water out of trenches with a pump or drainage system, and inspect the area for soil movement and potential cave-ins.
- Open ditches more than 24 hours or overnight must have fence protection.
- Keep drivers in the cab and workers away when dirt and other debris are being loaded into dump trucks. Workers must never be allowed under any load and must stay clear of the back of vehicles.

8. TOOLS AND EQUIPMENT

- Maintain all hand tools and equipment in safe condition and check regularly for defects. Broken or damaged tools and equipment must be removed from the jobsite.
- Use double insulated tools, or ensure the tools are grounded (check for ground plug).
- Equip all power saws (circular, skill, table, etc) with blade guards. Saws must be turned off when unattended. Unplug all power tools when not in use.
- Make sure cords are not damaged. The outer insulation must not be cut or damaged.
- Pneumatic and powder-actuated tools must only be used by trained and experienced personnel. Require proper eye protection for workers.
- Never leave cartridges for pneumatic or powder-actuated tools unattended. Keep equipment in a safe place, according to manufacturer's instructions.

9. VEHICLES AND MOBILE EQUIPMENT

- Inform workers verbally and provide training to stay clear of backing and turning vehicles and equipment with rotating cabs.
- Maintain back-up alarms for equipment with limited rear view or use someone to help guide them back.
- Verify experience or provide training to crane and heavy equipment operators.
- Maintain at least 10 foot clearance from overhead power lines when operating equipment.
- Block up the raised bed when inspecting or repairing dump trucks.
- Use a tag line to control materials moved by a crane.

10. ELECTRICAL

- Prohibit work on new and existing energized (hot) electrical circuits until all power is shut off and a positive "Lockout/Tagout System" is in place.
- Maintain all electrical tools and equipment in safe condition and check regularly for defects.
- Broken or damaged tools and equipment must be removed from the jobsite.
- Protect all temporary power (including extension cords) with Ground Fault Circuit Interrupters (GFCI's). Plug into a GFCI protected temporary power pole, a GFCI protected generator, or use a GFCI extension cord to protect against shocks.
- Locate and identify overhead electrical power lines. Make sure that ladders, scaffolds, equipment or materials never come within 10 feet of electrical power lines.
- Exterior electrical must be approved (UL, NEMA, etc) for exterior use (no internal junction boxes).

11. FIRE PREVENTION

- Provide fire extinguishers near all welding, soldering or other ignition sources.
- Avoid spraying of paint, solvents or other types of flammable materials in rooms with poor ventilation. Build up of fumes and vapors can cause explosions or fires.
- Store gasoline and other flammable materials in a safety can outdoors or in an approved storage facility. (Metal cans with self-sealing lids).

12. CHEMICAL HAZARDS

All hazardous chemicals present in the workplace must have an up-to-date Material Safety Data Sheet (MSDS). All contractors shall maintain MSDS for chemicals used or stored at GSD facilities. All warnings and directions for use must be followed.

13. CONFINED SPACES

By definition, a **confined space**:

- Is large enough for an employee to enter fully and perform assigned work;
- Is not designed for continuous occupancy by the employee; and
- Has a limited or restricted means of entry or exit.

These spaces may include underground vaults, tanks, storage bins, pits and diked areas, vessels, silos and other similar areas.

By definition, a **permit-required confined space** has one or more of these characteristics:

- Contains or has the potential to contain a hazardous atmosphere;
- Contains a material with the potential to engulf someone who enters the space;
- Has an internal configuration that might cause an entrant to be trapped or asphyxiated by inwardly converging walls or by a floor that slopes downward and tapers to a smaller cross section; and/or
- Contains any other recognized serious safety or health hazards.

Entry into confined spaces without an evaluation is forbidden. Entry into permit-required confined spaces requires compliance with all OSHA requirements. Entry into non-permit spaces will require an evaluation by GSD Safety to confirm that conditions remain non-permit required.

Contractors that perform confined space entry activities are required to comply with OSHA regulations. GSD will not provide confined space rescue equipment.

14. LOCK-OUT/TAG-OUT

Before working on, repairing, adjusting or replacing equipment and machinery, all appropriate safety procedures, including lockout/tagout, must be utilized to place the machinery or equipment in a neutral or zero mechanical state.

Outside contractors are expected to have knowledge of lock-out/tag-out requirements.

Contractor Acknowledgement:

I, the undersigned, have read, reviewed and acknowledge my understanding of the General Services Division safety requirements, as set forth in this handbook. I am also aware that all applicable rules and regulations are to be followed, regardless of whether they are specifically mentioned in this handbook.

Contractor Representative (Print Name): Dan Barton

Contractor Representative Signature:  _____ Date: 9/21/2020

This signed acknowledgement must be signed and returned to the GSD Safety Section prior to start of project work.



State of West Virginia

PURCHASING DIVISION

Construction Bid Submission Review Form

This list has been provided for informational purposes only and is not to be construed as a complete list of request for quotation or bidding requirements for any individual construction project. This list does not and cannot include every item, mistake or oversight that could cause a contractor's bid to be disqualified. Rather, this list is intended to draw attention to some of the most common problems that the Purchasing Division encounters in the bidding process for construction projects. All potential bidders must read the request for quotation, all additional documents, and all instructions relating thereto ("Bid Documents") in their entirety to identify the actual request for quotation and bidding requirements. Failure to read the Bid Documents in their entirety and comply with the stated requirements contained therein may result in bid disqualification.

Errors That Shall Be Reason for Immediate Bid Disqualification

1. Failure to attend a mandatory pre-bid meeting
2. Failure to sign the bid
3. Failure to supply a valid bid bond or other surety approved by the state of West Virginia
4. Failure to meet any mandatory requirement of the solicitation
5. Failure to acknowledge receipt of Addenda (only if stipulated as mandatory)
6. Failure to submit bid prior to the bid opening date and time
7. Federal debarment
8. State of West Virginia debarment or suspension

Errors that May Be Reason for Bid Disqualification Before Contract Award

1. Debt to the state or political subdivision (must be cured prior to award)
2. Workers' Compensation or Unemployment Compensation delinquency (must be cured prior to award)
3. Not registered as a vendor with the state of West Virginia (must be cured prior to award)
4. Failure to obtain required bonds and/or insurance
5. Failure to provide the sub-contractor listing within one business day of bid opening or one business day of the request to do so by the Purchasing Division.
6. Failure to supply West Virginia contractor's license number with bid or within one day of Purchasing Division request to do so.
7. Failure to supply a signed drug-free workplace affidavit with bid or within one day of Purchasing Division request to do so.
8. Failure to use the provided solicitation form (only if stipulated as mandatory).
9. Failure to complete the Disclosure of Interested Parties to Contracts form (If contract has an actual or estimated value of \$1 million or more; does not apply to publicly traded companies listed on national or internal stock exchange)

STATE OF WEST VIRGINIA
Purchasing Division

PURCHASING AFFIDAVIT

CONSTRUCTION CONTRACTS: Under W. Va. Code § 5-22-1(f), the contracting public entity shall not award a construction contract to any bidder that is known to be in default on any monetary obligation owed to the state or a political subdivision of the state, including, but not limited to, obligations related to payroll taxes, property taxes, sales and use taxes, fire service fees, or other fines or fees.

ALL CONTRACTS: Under W. Va. Code §5A-3-10a, no contract or renewal of any contract may be awarded by the state or any of its political subdivisions to any vendor or prospective vendor when the vendor or prospective vendor or a related party to the vendor or prospective vendor is a debtor and: (1) the debt owed is an amount greater than one thousand dollars in the aggregate; or (2) the debtor is in employer default.

EXCEPTION: The prohibition listed above does not apply where a vendor has contested any tax administered pursuant to chapter eleven of the W. Va. Code, workers' compensation premium, permit fee or environmental fee or assessment and the matter has not become final or where the vendor has entered into a payment plan or agreement and the vendor is not in default of any of the provisions of such plan or agreement.

DEFINITIONS:

"Debt" means any assessment, premium, penalty, fine, tax or other amount of money owed to the state or any of its political subdivisions because of a judgment, fine, permit violation, license assessment, defaulted workers' compensation premium, penalty or other assessment presently delinquent or due and required to be paid to the state or any of its political subdivisions, including any interest or additional penalties accrued thereon.

"Employer default" means having an outstanding balance or liability to the old fund or to the uninsured employers' fund or being in policy default, as defined in W. Va. Code § 23-2c-2, failure to maintain mandatory workers' compensation coverage, or failure to fully meet its obligations as a workers' compensation self-insured employer. An employer is not in employer default if it has entered into a repayment agreement with the Insurance Commissioner and remains in compliance with the obligations under the repayment agreement.

"Related party" means a party, whether an individual, corporation, partnership, association, limited liability company or any other form or business association or other entity whatsoever, related to any vendor by blood, marriage, ownership or contract through which the party has a relationship of ownership or other interest with the vendor so that the party will actually or by effect receive or control a portion of the benefit, profit or other consideration from performance of a vendor contract with the party receiving an amount that meets or exceeds five percent of the total contract amount.

AFFIRMATION: By signing this form, the vendor's authorized signer affirms and acknowledges under penalty of law for false swearing (W. Va. Code §§1-5-3) that: (1) for construction contracts, the vendor is not in default on any monetary obligation owed to the state or a political subdivision of the state, and (2) for all other contracts, that neither vendor nor any related party owe a debt as defined above and that neither vendor nor any related party are in employer default as defined above, unless the debt or employer default is permitted under the exception above.

WITNESS THE FOLLOWING SIGNATURE:

Vendor's Name: Grae-Con Construction, Inc.

Authorized Signature: Robert A. Gribben, III Date: September 21, 2020
Robert A. Gribben, III - Vice President

State of Ohio

County of Jefferson, to-wit:

Taken, subscribed, and sworn to before me this 21st day of September, 2020.

My Commission expires April 10, 2021.

AFFIX SEAL HERE

NOTARY PUBLIC

Kayla Stock

Purchasing Affidavit (Revised 01/10/2016)



KAYLA STOCK
Notary Public, State of Ohio
My Comm. Expires April 10, 2021
Recorded in Jefferson County



**State of West Virginia
DRUG FREE WORKPLACE CONFORMANCE AFFIDAVIT
West Virginia Code §21-1D-5**

I, Robert A. Gribben, III, after being first duly sworn, depose and state as follows:

1. I am an employee of Grae-Con Construction, Inc.; and,
(Company Name)
2. I do hereby attest that Grae-Con Construction, Inc.
(Company Name)

maintains a written plan for a drug-free workplace policy and that such plan and policy are in compliance with **West Virginia Code §21-1D**.

The above statements are sworn to under the penalty of perjury.

Printed Name: Robert A. Gribben, III
 Signature: Robert A. Gribben, III / gsg
 Title: Vice President
 Company Name: Grae-Con Construction, Inc.
 Date: September 21, 2020

Ohio
~~STATE OF WEST VIRGINIA,~~

COUNTY OF Jefferson, TO-WIT:

Taken, subscribed and sworn to before me this 21st day of September, 2020.

By Commission expires April 10, 2021

(Seal)

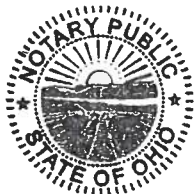

KAYLA STOCK
Notary Public, State of Ohio
My Comm. Expires April 10, 2021
Recorded in Jefferson County

Kayla Stock
(Notary Public)

State of West Virginia
Purchasing Division

CERTIFIED DRUG-FREE WORKPLACE REPORT COVERSHEET

In accordance with *West Virginia Code § 21-1D-7b*, no less than once per year, or upon completion of the project, every contractor shall provide a certified report to the public authority which let the contract. That report must include each of the items identified below in the Required Report Content section.

Instructions: Vendor should complete this coversheet, attach it to the required report, and submit it to the appropriate location as follows: For contracts more than \$25,000, the report should be mailed to the West Virginia Purchasing Division at 2019 Washington Street East, Charleston, WV 25305. For contracts of \$25,000 or less, the vendor should mail the report to the public authority issuing the contract.

Contract Identification:

Contract Number: CRFQ 0211 GSD21000012

Contract Purpose: Water Pump/Motor Skid Replacement B11

Agency Requesting Work: Department of Administration, Purchasing Division

Required Report Content: The attached report must include each of the items listed below. The vendor should check each box as an indication that the required information has been included in the attached report.

- Information indicating the education and training service to the requirements of *West Virginia Code § 21-1D-5* was provided;
- Name of the laboratory certified by the United States Department of Health and Human Services or its successor that performs the drug tests;
- Average number of employees in connection with the construction on the public improvement;
- Drug test results for the following categories including the number of positive tests and the number of negative tests: (A) Pre-employment and new hires; (B) Reasonable suspicion; (C) Post-accident; and (D) Random.

Vendor Contact Information:

Vendor Name: Grae-Con Construction, Inc.

Vendor Telephone: (740)282-6830

Vendor Address: 880 Kingsdale Road - PO Box 880

Vendor Fax: (740)282-6849

Steubenville, OH 43952

Vendor E-Mail: rob@graecon.com

BID BOND PREPARATION INSTRUCTIONS

AGENCY (A) _____
 RPQR/FP# (B) _____

- (A) WV State Agency
(Stated on Page 1 "Spending Unit")
- (B) Request for Quotation Number (upper right corner of page #1)
- (C) Your Business Entity Name (or Individual Name if Sole Proprietor)
- (D) City, Location of your Company
- (E) State, Location of your Company
- (F) Surety Corporate Name
- (G) City, Location of Surety
- (H) State, Location of Surety
- (I) State of Surety Incorporation
- (J) City of Surety's Principal Office
- (K) Minimum amount of acceptable bid bond is 5% of total bid. You may state "5% of bid" or a specific amount on this line in words.
- (L) Amount of bond in numbers
- (M) Brief Description of scope of work
- (N) Day of the month
- (O) Month
- (P) Year
- (Q) Name of Business Entity (or Individual Name if Sole Proprietor)
- (R) Seal of Principal
- (S) Signature of President, Vice President, or Authorized Agent
- (T) Title of Person Signing for Principal
- (U) Seal of Surety
- (V) Name of Surety
- (W) Signature of Attorney in Fact of the Surety

Bid Bond
 KNOW ALL MEN BY THESE PRESENTS, That we, the undersigned,
 _____ (C) _____ of _____ (D) _____ (E)
 as Principal, and _____ (F) _____ of _____ (G) _____
 _____ (H) _____, a corporation organized and existing under the laws
 of the State of _____ (I) _____ with its principal office in the City of
 _____ (J) _____, as Surety, are held and firmly bound unto The State
 of West Virginia, as Obligees, in the penal sum of _____ (K)
 (\$ _____ (L) _____) for the payment of which, well and truly to be made,
 we jointly and severally bind ourselves, our heirs, administrators, executors,
 successors and assigns.

The Condition of the above obligation is such that whereas the Principal has submitted to the Purchasing Section of the Department of Administration a certain bid or proposal, attached hereto and made a part hereof to enter into a contract in writing for _____

_____ (M) _____

NOW THEREFORE

(a) If said bid shall be rejected, or
 (b) If said bid shall be accepted and the Principal shall enter into a contract in accordance with the bid or proposal attached hereto and shall furnish any other bonds and insurance required by the bid or proposal, and shall in all other respects perform the agreement created by the acceptance of said bid then this obligation shall be null and void, otherwise this obligation shall remain in full force and effect. It is expressly understood and agreed that the liability of the Surety for any and all claims hereunder shall, in no event, exceed the penal amount of this obligation as herein stated.

The Surety for value received, hereby stipulates and agrees that the obligations of said Surety and its bond shall be in no way impaired or affected by any extension of time within which the Obligees may accept such bid: and said Surety does hereby waive notice of any such extension.

WITNESS, the following signatures and seals of Principal and Surety, executed and sealed by a proper officer of Principal and Surety, or by Principal individually if Principal is an individual, the _____ (N) _____ day of _____ (O) _____, 20 _____ (P) _____.

Principal Seal _____ (Q)
 _____ (R) (Name of Principal)

By _____ (S)
 (Must be President, Vice President, or
 Duty Authorized Agent)

_____ (T)
 _____ (Title)

Surety Seal _____ (U)
 _____ (V) (Name of Surety)

_____ (W)
 _____ (Attorney-in-Fact)

NOTE 1: Dated Power of Attorney with Surety Seal must accompany this bid bond.

IMPORTANT – Surety executing bonds must be licensed in West Virginia to transact surety insurance, must affix its seal, and must attach a power of attorney with its seal affixed.

Agency _____
REQ.P.O# _____

BID BOND

KNOW ALL MEN BY THESE PRESENTS, That we, the undersigned, Grae-Con Construction, Inc.
of Steubenville Ohio, as Principal, and Ohio Farmers Insurance Company
of Westfield Center, Ohio, a corporation organized and existing under the laws of the State of Ohio
with its principal office in the City of Westfield Center, as Surety, are held and firmly bound unto the State
of West Virginia, as Obligees, in the penal sum of 5% of total amount bid (\$ _____) for the payment of which,
well and truly to be made, we jointly and severally bind ourselves, our heirs, administrators, executors, successors and assigns.

The Condition of the above obligation is such that whereas the Principal has submitted to the Purchasing Section of the
Department of Administration a certain bid or proposal, attached hereto and made a part hereof, to enter into a contract in writing for
Water Pump/Motor Skid Replacement B.11
Charleston, WV

NOW THEREFORE,

- (a) If said bid shall be rejected, or
- (b) If said bid shall be accepted and the Principal shall enter into a contract in accordance with the bid or proposal attached hereto and shall furnish any other bonds and insurance required by the bid or proposal, and shall in all other respects perform the agreement created by the acceptance of said bid, then this obligation shall be null and void, otherwise this obligation shall remain in full force and effect. It is expressly understood and agreed that the liability of the Surety for any and all claims hereunder shall, in no event, exceed the penal amount of this obligation as herein stated.

The Surety, for the value received, hereby stipulates and agrees that the obligations of said Surety and its bond shall be in no way impaired or affected by any extension of the time within which the Obligees may accept such bid, and said Surety does hereby waive notice of any such extension.

WITNESS, the following signatures and seals of Principal and Surety, executed and sealed by a proper officer of Principal and Surety, or by Principal individually if Principal is an individual, this 21st day of September, 2020.

Principal Seal

Grae-Con Construction, Inc.
(Name of Principal)
By [Signature]
(Must be President, Vice President, or Duly Authorized Agent)
Vice President
(Title)

Surety Seal

Ohio Farmers Insurance Company
(Name of Surety)
[Signature]
Debbie Hukill, Attorney-in-Fact

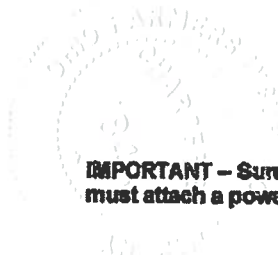

IMPORTANT – Surety executing bonds must be licensed in West Virginia to transact surety insurance, must affix its seal, and must attach a power of attorney with its seal affixed.

General
Power
of Attorney

CERTIFIED COPY

POWER NO. 3408162 01

**Westfield Insurance Co.
Westfield National Insurance Co.
Ohio Farmers Insurance Co.**
Westfield Center, Ohio

Know All Men by These Presents, That WESTFIELD INSURANCE COMPANY, WESTFIELD NATIONAL INSURANCE COMPANY and OHIO FARMERS INSURANCE COMPANY, corporations, hereinafter referred to individually as a "Company" and collectively as "Companies," duly organized and existing under the laws of the State of Ohio, and having its principal office in Westfield Center, Medina County, Ohio, do by these presents make, constitute and appoint
DEBBIE HUKILL, JEFF CRISS, DEANNE ROY, JOINTLY OR SEVERALLY

of STEUBENVILLE and State of OH its true and lawful Attorney(s)-in-Fact, with full power and authority hereby conferred in its name, place and stead, to execute, acknowledge and deliver any and all bonds, recognizances, undertakings, or other instruments or contracts of suretyship-

LIMITATION: THIS POWER OF ATTORNEY CANNOT BE USED TO EXECUTE NOTE GUARANTEE, MORTGAGE DEFICIENCY, MORTGAGE GUARANTEE, OR BANK DEPOSITORY BONDS.

and to bind any of the Companies thereby as fully and to the same extent as if such bonds were signed by the President, sealed with the corporate seal of the applicable Company and duly attested by its Secretary, hereby ratifying and confirming all that the said Attorney(s)-in-Fact may do in the premises. Said appointment is made under and by authority of the following resolution adopted by the Board of Directors of each of the WESTFIELD INSURANCE COMPANY, WESTFIELD NATIONAL INSURANCE COMPANY and OHIO FARMERS INSURANCE COMPANY:

"Be It Resolved, that the President, any Senior Executive, any Secretary or any Fidelity & Surety Operations Executive or other Executive shall be and is hereby vested with full power and authority to appoint any one or more suitable persons as Attorney(s)-in-Fact to represent and act for and on behalf of the Company subject to the following provisions:

The Attorney-in-Fact. may be given full power and authority for and in the name of and on behalf of the Company, to execute, acknowledge and deliver, any and all bonds, recognizances, contracts, agreements of indemnity and other conditional or obligatory undertakings and any and all notices and documents canceling or terminating the Company's liability thereunder, and any such instruments so executed by any such Attorney-in-Fact shall be as binding upon the Company as if signed by the President and sealed and attested by the Corporate Secretary."

"Be it Further Resolved, that the signature of any such designated person and the seal of the Company heretofore or hereafter affixed to any power of attorney or any certificate relating thereto by facsimile, and any power of attorney or certificate bearing facsimile signatures or facsimile seal shall be valid and binding upon the Company with respect to any bond or undertaking to which it is attached." (Each adopted at a meeting held on February 8, 2000).

In Witness Whereof, WESTFIELD INSURANCE COMPANY, WESTFIELD NATIONAL INSURANCE COMPANY and OHIO FARMERS INSURANCE COMPANY have caused these presents to be signed by their National Surety Leader and Senior Executive and their corporate seals to be hereto affixed this 21st day of MARCH A.D., 2014 .

Corporate
Seals
Affixed



WESTFIELD INSURANCE COMPANY
WESTFIELD NATIONAL INSURANCE COMPANY
OHIO FARMERS INSURANCE COMPANY

By: *Dennis P. Baus*
Dennis P. Baus, National Surety Leader and Senior Executive

State of Ohio
County of Medina ss.:

On this 21st day of MARCH A.D., 2014 , before me personally came Dennis P. Baus to me known, who, being by me duly sworn, did depose and say, that he resides in Wooster, Ohio; that he is National Surety Leader and Senior Executive of WESTFIELD INSURANCE COMPANY, WESTFIELD NATIONAL INSURANCE COMPANY and OHIO FARMERS INSURANCE COMPANY, the companies described in and which executed the above instrument; that he knows the seals of said Companies; that the seals affixed to said instrument are such corporate seals; that they were so affixed by order of the Boards of Directors of said Companies; and that he signed his name thereto by like order.

Notarial
Seal
Affixed



David A. Kotnik
David A. Kotnik, Attorney at Law, Notary Public
My Commission Does Not Expire (Sec. 147.03 Ohio Revised Code)

State of Ohio
County of Medina ss.:

I, Frank A. Carrino, Secretary of WESTFIELD INSURANCE COMPANY, WESTFIELD NATIONAL INSURANCE COMPANY and OHIO FARMERS INSURANCE COMPANY, do hereby certify that the above and foregoing is a true and correct copy of a Power of Attorney, executed by said Companies, which is still in full force and effect; and furthermore, the resolutions of the Boards of Directors, set out in the Power of Attorney are in full force and effect.

In Witness Whereof, I have hereunto set my hand and affixed the seals of said Companies at Westfield Center, Ohio, this 21st day of September A.D., 2020 .

Corporate
Seals
Affixed



Frank A. Carrino
Frank A. Carrino, Secretary

**Financial
Statement**

December 31, 2019

Ohio Farmers Insurance Co.

Westfield Center, Ohio 44251-5001

**OHIO FARMERS INSURANCE COMPANY
BALANCE SHEET**

12/31/19
(in thousands)

Assets	
Cash, cash equivalents, and short term investments	29,473
Bonds	444,935
Stocks	144,750
Subsidiaries	2,206,906
Real estate	160,044
Premiums receivable	112,354
Other assets	172,187
Total assets	3,270,649
Liabilities	
Reserve for unearned premiums	167,924
Reserve for unpaid losses and loss expenses	332,025
Reserve for taxes and other liabilities	259,523
Total liabilities	759,472
Surplus	
Surplus to policyholders	2,511,177
Total surplus	2,511,177
Total liabilities and surplus	3,270,649

State of Ohio

ss:

County of Medina

The undersigned, being duly sworn, says: That he is National Surety Leader - Surety Operations of Ohio Farmers Insurance Company, Westfield Center, Ohio; that said Company is a corporation duly organized, existing and engaged in business as a Surety Company by virtue of the Laws of the State of Ohio and authorized to do business in the State of ~~Ohio~~ West Virginia and has duly complied with all the requirements of the laws of said State applicable to said Company and is duly qualified to act as Surety under such laws; that said Company has also complied with and is duly qualified to act as Surety under the Act of Congress approved July 1947, 6 U.S.C. sec. 6-13; and that to the best of his knowledge and belief the above statement is a full, true, and correct statement of the financial condition of the said Company on the 31st day of December, 2019.

Attest:

Frank Carrino

Frank A. Carrino
Group Legal Leader, Secretary

Gary W. Stumper

Gary W. Stumper
National Surety Leader
Senior Executive

Sworn to before me this 12th day of February A.D. 2020.

David A. Kotnik

David A. Kotnik
Attorney at Law
Notary Public – State of Ohio



**ADDENDUM ACKNOWLEDGEMENT FORM
SOLICITATION NO.:**

Instructions: Please acknowledge receipt of all addenda issued with this solicitation by completing this addendum acknowledgment form. Check the box next to each addendum received and sign below. Failure to acknowledge addenda may result in bid disqualification.

Acknowledgment: I hereby acknowledge receipt of the following addenda and have made the necessary revisions to my proposal, plans and/or specification, etc.

Addendum Numbers Received:

(Check the box next to each addendum received)

- | | |
|--|--|
| <input checked="" type="checkbox"/> Addendum No. 1 | <input type="checkbox"/> Addendum No. 6 |
| <input type="checkbox"/> Addendum No. 2 | <input type="checkbox"/> Addendum No. 7 |
| <input type="checkbox"/> Addendum No. 3 | <input type="checkbox"/> Addendum No. 8 |
| <input type="checkbox"/> Addendum No. 4 | <input type="checkbox"/> Addendum No. 9 |
| <input type="checkbox"/> Addendum No. 5 | <input type="checkbox"/> Addendum No. 10 |

I understand that failure to confirm the receipt of addenda may be cause for rejection of this bid. I further understand that any verbal representation made or assumed to be made during any oral discussion held between Vendor's representatives and any state personnel is not binding. Only the information issued in writing and added to the specifications by an official addendum is binding.

Grae-Con Construction, Inc.

Company

Robert A. Gribben, III / RS

Authorized Signature Robert A. Gribben, III - Vice President

September 21, 2020

Date

NOTE: This addendum acknowledgement should be submitted with the bid to expedite document processing.



State of West Virginia
Water Pump/Motor Skid Replacement

September 21, 2020

Re: Water Pump/Motor Skid Replacement
Solicitation No.
GRAE-CON Proposal No. 020398

Corporate Office

P.O. Box 1778
880 Kingsdale Road
Steubenville, OH 43952

Phone: 740/282-6830
Fax: 740/282-6849

Regional Office

101 Industry Road
Marietta, OH 45750

Phone: 740/373-0849
Fax: 740/373-0863

Clarifications & Qualifications:

1. Our proposal is based on a 40 hour work week. No premium time has been included.
2. Grae-con has not included cost associated with a diffuser for either flange connection. If a diffuser is required the following would be our add price for the material:
12" side double suction diffuser - \$6,428.00 ADD to our proposal
10" side double suction diffuser - \$6,262.00 ADD to our proposal
3. Grae-con has only included for disconnect and re-connect of the current electrical system from the old pump to the new unit.
4. Grae-con has assumed clear access to pump area for removal and re-installation.
5. Grae-con has included cut sheets form Bell & Gossett for the Pump & Motor skid priced within this proposal for your review.
6. Grae-con has assumed in-service testing of new unit after installation.
7. Pricing does not include for starter, disconnects, variable frequency drives, power factor correction capacitors or any other controls.
8. Pricing does not include spare parts such as seals, gaskets or ignitors.

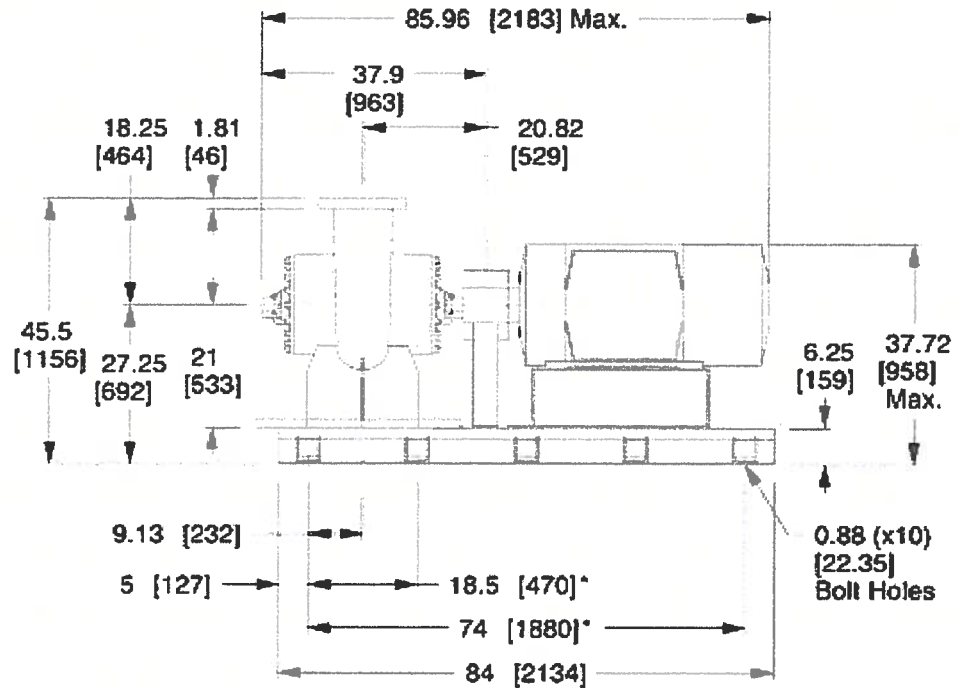
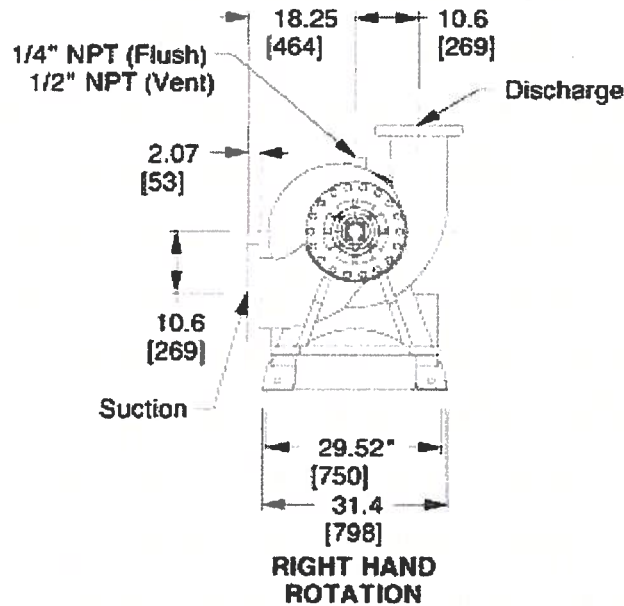
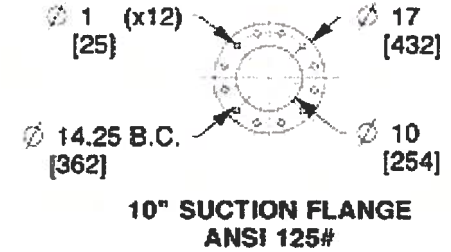
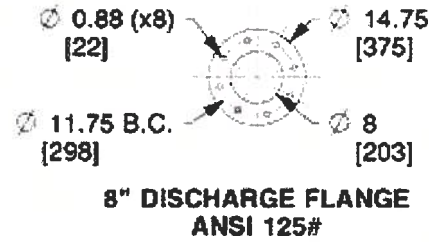
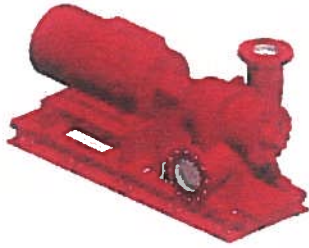

* Dist. Between Bolt Holes



Bell & Gossett
a xylem brand

8200 N. Austin Ave.
Morton Grove, IL 60053, USA

This drawing and the information depicted therein is the property of Xylem. Copies are issued in strict confidence and shall not be reproduced or copied, or used as the basis for the manufacture or sale of products without prior written permission of Xylem.

Dimensions are subject to change
Not to be used for construction unless certified

VSCS-8X10X13P5A-405TTS-SPR

Series vscs Double Suction Split Case Pump
Motor Frame: 405T/TS | Coupler: Spacer Coupler | Hand of Rotation: Right Hand
Removal Clearance: 24 | Flange: ANSI 125#

Dimensions : IN (mm)

Scale : N.T.S.

Submittal # : B-857.2D

Job/Project: 2050047 VSCS 10x12x13L Replacement		Representative:	
ESP-Systemwize: WIZE-9F5335	Created On:	Phone:	
Location/Tag:		Email:	
Engineer:		Submitted By:	Date:
Contractor:		Approved By:	Date:

Double Suction Split Case Pump

Series: **VSX-VSCS**

Model: **8x10x13.5A**



Features & Design

- Space saving footprint
- Multiple suction and discharge flange orientations
- Maintenance-free bearings
- Alignment-friendly coupling

*The Bell & Gossett Series VSX-VSCS has maintenance-free Bearings, a one-piece unitized seal, groudless base plate, and alignment-friendly coupling.

© 2014 Bell & Gossett. All rights reserved. For more information, visit www.bellandgossett.com.

Pump Selection Summary

Duty Point Flow	2880.0 US gpm
Duty Point Head	120.0 ft
Control Head	0.0 ft
Duty Point Pump Efficiency	83.1 %
Part Load Efficiency Value (PLEV)	0.0 %
Impeller Diameter	11.875 in
Motor Power	125 hp
Duty Point Power	108 bhp
Motor Speed	1800 rpm
RPM @ Duty Point	1780 rpm
NPSHr	10.7 ft
Minimum Shutoff Head	152 ft
Minimum Flow at RPM	816 US gpm
Flow @ BEP	3265 US gpm
Fluid Temperature	68 °F
Fluid Type	Water
Weight (approx. - consult rep for exact)	3542 lbs
Pump Floor Space Calculation	20.3 ft ²

Performance Curve



VSX-VSCS

8x10x13.5A
1780 RPM

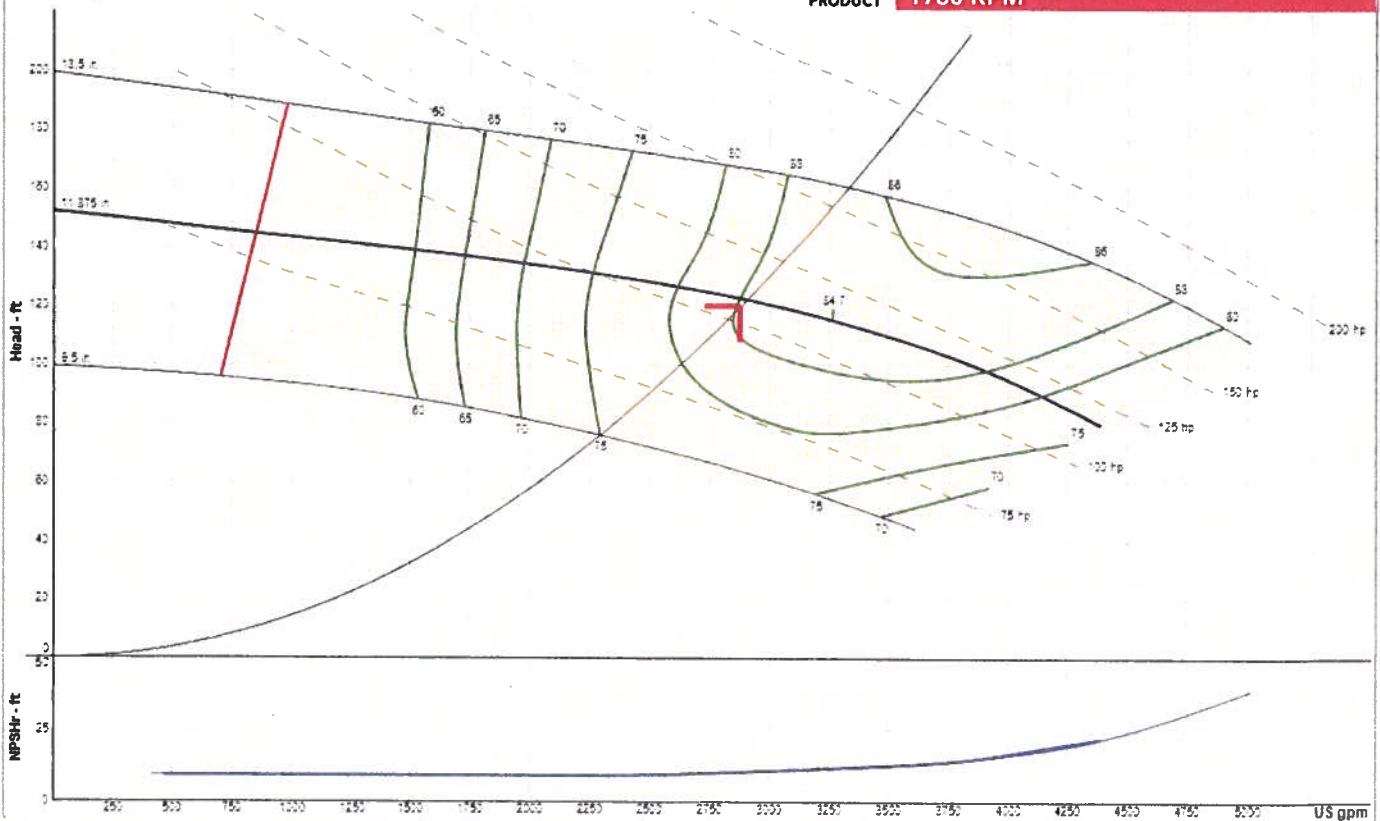

Performance curve meets 14.6 / ISO 9906 acceptance criteria

Materials Of Construction

Pump Information\Construction	
Pump Series	VSX-VSCS
Pump Size	8 x 10 x 13-1/2A
Seal Type	Standard Seal
Seal Material	Unitized EPR-Carbon/SiC
Material of Construction	Bronze Fitted
Impeller Diameter	11.875 inches
Sleeve Material	Standard
Rotation	Right Hand Rotation

Motor Details	
Motor Power	125
Motor Speed	1800
Frequency	60
Phase	3
Voltage	460
Frame	405T
Enclosure	ODP
Motor Manufacturer	BG Choice
Motor Status	Factory
Motor Comments	NEMA Premium Efficient, w/Aegis SGR
RepMtrEfficiency	PRM

Selected Options	
Selected Option 1	Woods Duraflex Spacer

Standard Materials of Construction *contact your local rep for optional ES Bearing Frame

Construction:	Bronze Fitted
Volute:	Cast Iron ASTM A159 with some exceptions
Shaft:	1045 Steel
Shaft Sleeve:	304 SS
Impeller:	Low Zinc Silicon Bronze ASTM B584 Alloy C87600
Impeller Key	Stainless Steel
Retaining Ring	Stainless Steel
Coverplate	Gray Cast Iron
Gland	Gray Cast Iron
Bracket (In & Out)	Gray Cast Iron
Quad Ring	EPDM Rubber
Cap	Gray Cast Iron
Water Slinger	Neoprene Rubber
Bearing	Single Row, Ball Bearing with Shield
Lock Washer	Carbon Steel
Lock Nut	Carbon Steel
Lip Seal	Steel with Nitrile Rubber Jacket
Bearing Backup Ring	Stainless Steel
Alignment Friendly Coupling	Non-Spacer, elastomeric
Coupler Guard:	ANSI/OSHA Compliant, Fully Enclosed
Baseplate:	Groutless Reinforced Structural Steel with lifting lugs

Standard Mechanical Seal Assembly

Elastomer:	EPR
Rotating Face:	Carbon
Stationary Face:	Graphite Loaded Silicon Carbon
Hardware	Stainless Steel/Brass

Maximum Working Pressure

Max Working Pressure (standard)	175 psi
Max Working Pressure (optional)	300 psi
Max Working Temperature (standard)	300
Max Working Temperature (optional)	225 - 300

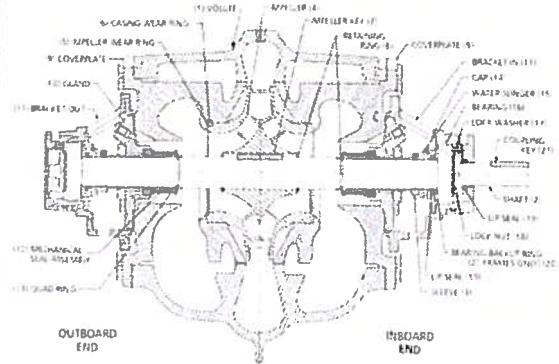

PRODUCT DESCRIPTION

FLANGE ADAPTERS are designed to connect larger or smaller flanged piping components together in a minimum face to face dimension. They have tapped holes for connection to 125# ANSI mating flanges using cap screws or studs and nuts of the size specified for the mating flange. They are particularly advantageous in limited spaces such as equipment rooms and frame mounted packages for interconnection of valves, fittings, strainers, and flexible connectors.

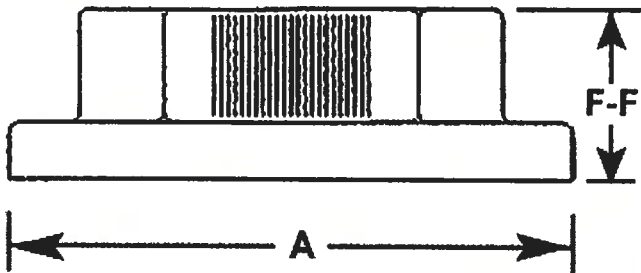
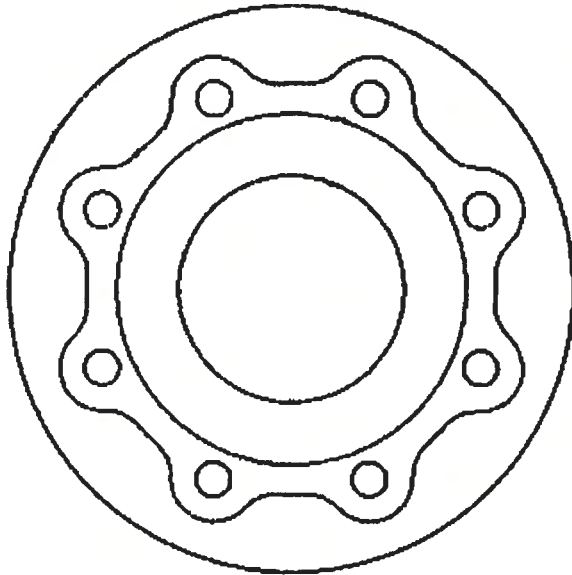

Material: Cast Iron (CL B min)

Working Pressure: Complies with ANSI B16.1 for class 125 fittings

Model	A 125# FLG	B 125# FLG	F-F In
FCC3025	3	2-1/2	2-1/2
FCC4025	4	2-12	2-1/2
FCC4030	4	3	2-1/2
FCC5030	5	3	3-1/2
FCC5040	5	4	3
FCC6040	6	4	3-1/2
FCC6050	6	5	3
FCC8050	8	5	3-1/2
FCC8060	8	6	3-1/2
FCC1080	10	8	3-1/2
FCC1210	12	10	3-1/2
FCC1412	14	12	3-1/2

Flange		Cap Screws		
Size	Thickness In	QTY.	Size	Length In
2--1/2	11/16	4	5/8-11	2
2--1/2	1	4	5/8-11	2-1/4
3	3/4	4	5/8-11	2
3	1-1/8	4	5/8-11	2-1/4
4	1-5/16	8	5/8-11	2
4	1-1/4	8	5/8-11	2-1/2
5	1-5/16	8	3/4-10	2-1/4
5	1-3/8	8	3/4-10	2-3/4
6	1	8	3/4-10	2-1/4
6	1-7/16	8	3/4-10	2-3/4
8	1-1/8	8	3/4-10	2-1/2
8	1-5/8	8	3/4-10	3
10	1-3/16	12	7/8-9	2-3/4
10	1-7/8	12	7/8-9	3-1/2
12	1-1/4	12	7/8-9	2-3/4
12	2	12	7/8-9	3-1/2
14	1-3/8	12	1-8	3
14	2-1/8	12	1-8	3-3/4

Low Tensile-A307 Grade B Cap Screws Required for Connection to Mating ANSI Flange with 1/8" Resilient Gasket.

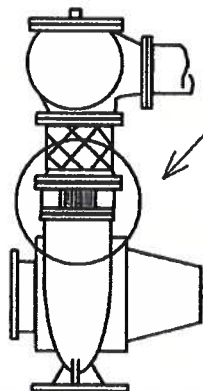

6" Triple Duty Valve and Flexible Connector, Shown Connected to 5" End Suction Pump Discharge with 6050 FLANGE ADAPTER.

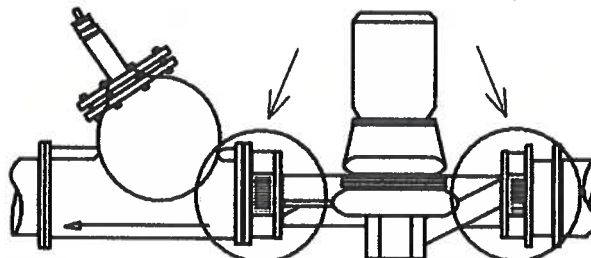

6" Wafer Butterfly Valve with 6040 FLANGE ADAPTER and 6" Triple Duty Valve with 6040 FLANGE ADAPTER, Shown with 4" In Line Pump.



FLOW CONDITIONING CORP.

WWW.FLOW-C.COM

12 KIMLER DRIVE MARYLAND HEIGHTS, MO 63043-3797 (314) 878-7898 FAX (314) 878-6029