

RECEIVED

2019 JUL 17 PM 1:22

WV PURCHASING  
DIVISION

CRFQ DOT1900000128

**VENDOR:** Worldwide Equipment **Class 371 41,000 GVWR Single Axle Dump Truck**

| Item No.              | Description:   | Model & Part Number Being Bid  | Estimated Unit Quantity | Unit Price   | Item Total Cost        |
|-----------------------|--|--|-------------------------|--------------|------------------------|
| 1                     | Cab Chassis/Dump Body w/Hyd. And Spreader Control System | IH HV507 SFA<br>Viking DB126x86x30SA   | 120                     | \$142,675.04 | \$17,121,004.80        |
| 2                     | Front 10 Ft. Snow Plow with plow mount                   | Viking Model MW3OR10   | 120                     | \$11,682.00  | \$1,401,840.00         |
| 3                     | Front 11 Ft. Snow Plow with plow mount                   | Viking Model MW3OR11   | 120                     | \$12,632.00  | \$1,515,840.00         |
| 4                     | V-Box Spreader   | Viking Model VBA114  | 120                     | \$19,955.00  | \$2,394,600.00         |
| <b>Total Bid Cost</b> |  |  |                         |              | <b>\$22,433,284.80</b> |

**Bid Will Be Awarded To The Lowest Overall Bid Total For All Items**

**Vendor Information**

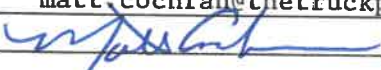
|                         |   |
|-------------------------|---|
| <b>Company Name:</b>    | Worldwide Equipment   |
| <b>Contact Manager:</b> | Matt Cochran, Regional Sales Manager  |
| <b>Address:</b>         | 5650 US Route 60 East, Huntington, WV 25705   |
| <b>Phone:</b>           | 304-345-2490 office, 304-208-2542 cell  |
| <b>Fax:</b>             | 304-759-9807  |
| <b>E-mail:</b>          | matt.cochran@thetruckpeople.com   |
| <b>Signature:</b>       |  |



Purchasing Division  
 2019 Washington Street East  
 Post Office Box 50130  
 Charleston, WV 25305-0130

State of West Virginia  
 Request for Quotation  
 19 – Highways

Proc Folder: 589305

Doc Description: ADDENDUM 2 41K GVWR SINGLE AXLE DUMP TRUCK (7019EC16)

Proc Type: Central Master Agreement

| Date Issued | Solicitation Closes    | Solicitation No         | Version |
|-------------|------------------------|-------------------------|---------|
| 2019-07-09  | 2019-07-17<br>13:30:00 | CRFQ 0803 DOT1900000128 | 3       |

**BID RECEIVING LOCATION**

BID CLERK  
 DEPARTMENT OF ADMINISTRATION  
 PURCHASING DIVISION  
 2019 WASHINGTON ST E  
 CHARLESTON WV 25305  
 US

**VENDOR**

Vendor Name, Address and Telephone Number:

Worldwide Equipment  
 5650 US Route 60 East  
 Huntington, WV 25705  
 304-345-2490

**FOR INFORMATION CONTACT THE BUYER**

Crystal G Hustead  
 (304) 558-2402  
 crystal.g.hustead@wv.gov

Signature X

FEIN # 45-1024981

DATE 7/16/19

All offers subject to all terms and conditions contained in this solicitation



Purchasing Division  
 2019 Washington Street East  
 Post Office Box 50130  
 Charleston, WV 25305-0130

State of West Virginia  
 Request for Quotation  
 19 – Highways

Proc Folder: 589305

Doc Description: 41K GVWR SINGLE AXLE DUMP TRUCK (7019EC16)

Proc Type: Central Master Agreement

| Date Issued | Solicitation Closes    | Solicitation No         | Version |
|-------------|------------------------|-------------------------|---------|
| 2019-06-10  | 2019-07-11<br>13:30:00 | CRFQ 0803 DOT1900000128 | 1       |

**BID RECEIVING LOCATION**

BID CLERK  
 DEPARTMENT OF ADMINISTRATION  
 PURCHASING DIVISION  
 2019 WASHINGTON ST E  
 CHARLESTON WV 25305  
 US

**VENDOR**

Vendor Name, Address and Telephone Number:

**FOR INFORMATION CONTACT THE BUYER**

Crystal G Husted  
 (304) 558-2402  
 crystal.g.husted@wv.gov

Signature X

FEIN #

DATE

All offers subject to all terms and conditions contained in this solicitation

**ADDITIONAL INFORMATION:**

THE WEST VIRGINIA PURCHASING DIVISION IS SOLICITING BIDS ON BEHALF OF THE WEST VIRGINIA DIVISION OF HIGHWAYS, DEPARTMENT OF TRANSPORTATION, TO ESTABLISH AN OPEN-END CONTRACT FOR A 41,000 GVWR SINGLE AXLE DUMP TRUCK WITH SNOW PLOW AND V-BOX SPREADER PER THE ATTACHED DOCUMENTS.

| INVOICE TO  |  | SHIP TO   |  |
|---|--|---|--|
| DIVISION OF HIGHWAYS<br>EQUIPMENT DIVISION RT 33<br>83 BRUSHY ROAD CROSSING, PO BOX 610<br>BUCKHANNON WV26201<br>US |  | DIVISION OF HIGHWAYS<br>EQUIPMENT DIVISION<br>83 BRUSHY FORK RD CROSSING<br>BUCKHANNON WV 26201<br>US |  |

| Line | Comm Ln Desc                 | Qty       | Unit Issue | Unit Price | Total Price |
|------|------------------------------|-----------|------------|------------|-------------|
| 1    | 41,000 GVWR Single Axle Dump | 120.00000 | EA         |            |             |

| Comm Code | Manufacturer | Specification | Model # |
|-----------|--------------|---------------|---------|
| 25101601  |              |               |         |

**Extended Description :**

41,000 GVWR Single Axle Dump Truck w/snowplow and V-Box Spreader

| INVOICE TO  |  | SHIP TO   |  |
|---|--|---|--|
| DIVISION OF HIGHWAYS<br>EQUIPMENT DIVISION RT 33<br>83 BRUSHY ROAD CROSSING, PO BOX 610<br>BUCKHANNON WV26201<br>US |  | DIVISION OF HIGHWAYS<br>EQUIPMENT DIVISION<br>83 BRUSHY FORK RD CROSSING<br>BUCKHANNON WV 26201<br>US |  |

| Line | Comm Ln Desc          | Qty       | Unit Issue | Unit Price | Total Price |
|------|-----------------------|-----------|------------|------------|-------------|
| 2    | FRONT 10FT. SNOW PLOW | 120.00000 | EA         |            |             |

| Comm Code | Manufacturer | Specification | Model # |
|-----------|--------------|---------------|---------|
| 25101601  |              |               |         |

**Extended Description :**

FRONT 10FT. SNOW PLOW

| INVOICE TO  |  | SHIP TO   |  |
|---|--|---|--|
| DIVISION OF HIGHWAYS<br>EQUIPMENT DIVISION RT 33<br>83 BRUSHY ROAD CROSSING, PO BOX 610<br>BUCKHANNON WV26201<br>US |  | DIVISION OF HIGHWAYS<br>EQUIPMENT DIVISION<br>83 BRUSHY FORK RD CROSSING<br>BUCKHANNON WV 26201<br>US |  |

| Line | Comm Ln Desc          | Qty       | Unit Issue | Unit Price | Total Price |
|------|-----------------------|-----------|------------|------------|-------------|
| 3    | FRONT 11FT. SNOW PLOW | 120.00000 | EA         |            |             |

| Comm Code | Manufacturer | Specification | Model # |
|-----------|--------------|---------------|---------|
| 25101601  |              |               |         |

Extended Description :  
FRONT 11FT. SNOW PLOW

| INVOICE TO  | SHIP TO   |
|---|---|
| DIVISION OF HIGHWAYS<br>EQUIPMENT DIVISION RT 33<br>83 BRUSHY ROAD CROSSING, PO BOX 610<br>BUCKHANNON WV26201<br>US | DIVISION OF HIGHWAYS<br>EQUIPMENT DIVISION<br>83 BRUSHY FORK RD CROSSING<br>BUCKHANNON WV 26201<br>US |

| Line | Comm Ln Desc   | Qty       | Unit Issue | Unit Price | Total Price |
|------|----------------|-----------|------------|------------|-------------|
| 4    | V-BOX SPREADER | 120.00000 | EA         |            |             |

| Comm Code | Manufacturer | Specification | Model # |
|-----------|--------------|---------------|---------|
| 25101601  |              |               |         |

Extended Description :  
V-BOX SPREADER

**SCHEDULE OF EVENTS**

| Line | Event                     | Event Date |
|------|---------------------------|------------|
| 1    | MANDATORY PRE-BID MEETING | 2019-06-25 |
| 2    | VENDOR QUESTION DEADLINE  | 2019-06-28 |

|                      |                                       |   |                              |
|----------------------|---------------------------------------|---|------------------------------|
| <b>DOT1900000128</b> | <b>Document Phase</b><br><b>Final</b> | <b>Document Description</b><br>41K GWR SINGLE AXLE DUMP TRUCK<br>(7019EC16) | <b>Page 4</b><br><b>of 4</b> |
|----------------------|---------------------------------------|---|------------------------------|

**ADDITIONAL TERMS AND CONDITIONS**

See attached document(s) for additional Terms and Conditions

EXHIBIT C

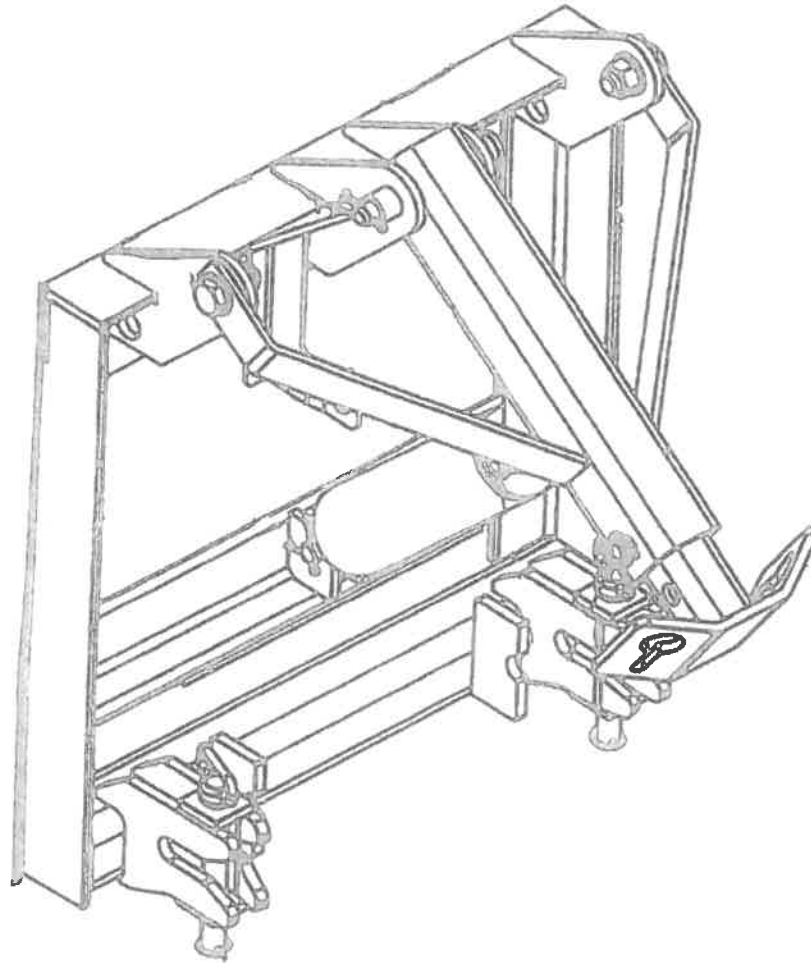

**WVDOH Plow Quick Hitch**

## **INSTRUCTIONS TO VENDORS SUBMITTING BIDS**

**1. REVIEW DOCUMENTS THOROUGHLY:** The attached documents contain a solicitation for bids. Please read these instructions and all documents attached in their entirety. These instructions provide critical information about requirements that if overlooked could lead to disqualification of a Vendor's bid. All bids must be submitted in accordance with the provisions contained in these instructions and the Solicitation. Failure to do so may result in disqualification of Vendor's bid.

**2. MANDATORY TERMS:** The Solicitation may contain mandatory provisions identified by the use of the words "must," "will," and "shall." Failure to comply with a mandatory term in the Solicitation will result in bid disqualification.

**3. PREBID MEETING:** The item identified below shall apply to this Solicitation.

A pre-bid meeting will not be held prior to bid opening

A **NON-MANDATORY PRE-BID** meeting will be held at the following place and time:

A **MANDATORY PRE-BID** meeting will be held at the following place and time:

Date and Time: June 25, 2019 at 10:00 AM EST

Location:

WV DOH Equipment Division  
83 Brushy Fork Road Crossing  
Buckhannon, WV 26201

All Vendors submitting a bid must attend the mandatory pre-bid meeting. Failure to attend the mandatory pre-bid meeting shall result in disqualification of the Vendor's bid. No one person attending the pre-bid meeting may represent more than one Vendor.

An attendance sheet provided at the pre-bid meeting shall serve as the official document verifying attendance. The State will not accept any other form of proof or documentation to verify attendance. Any person attending the pre-bid meeting on behalf of a Vendor must list on the attendance sheet his or her name and the name of the Vendor he or she is representing.



Additionally, the person attending the pre-bid meeting should include the Vendor's E-Mail address, phone number, and Fax number on the attendance sheet. It is the Vendor's responsibility to locate the attendance sheet and provide the required information. Failure to complete the attendance sheet as required may result in disqualification of Vendor's bid.

All Vendors should arrive prior to the starting time for the pre-bid. Vendors who arrive after the starting time but prior to the end of the pre-bid will be permitted to sign in, but are charged with knowing all matters discussed at the pre-bid.

Questions submitted at least five business days prior to a scheduled pre-bid will be discussed at the pre-bid meeting if possible. Any discussions or answers to questions at the pre-bid meeting are preliminary in nature and are non-binding. Official and binding answers to questions will be published in a written addendum to the Solicitation prior to bid opening.

**4. VENDOR QUESTION DEADLINE:** Vendors may submit questions relating to this Solicitation to the Purchasing Division. Questions must be submitted in writing. All questions must be submitted on or before the date listed below and to the address listed below in order to be considered. A written response will be published in a Solicitation addendum if a response is possible and appropriate. Non-written discussions, conversations, or questions and answers regarding this Solicitation are preliminary in nature and are nonbinding.

Submitted e-mails should have solicitation number in the subject line.

Question Submission Deadline: June 28, 2019 at 10:00 AM EST

Submit Questions to: Crystal Hustead  
2019 Washington Street, East  
Charleston, WV 25305  
Fax: (304) 558-4115 (Vendors should not use this fax number for bid submission)  
Email: [Crystal.G.Hustead@wv.gov](mailto:Crystal.G.Hustead@wv.gov)

**5. VERBAL COMMUNICATION:** Any verbal communication between the Vendor and any State personnel is not binding, including verbal communication at the mandatory pre-bid conference. Only information issued in writing and added to the Solicitation by an official written addendum by the Purchasing Division is binding.

**6. BID SUBMISSION:** All bids must be submitted electronically through wvOASIS or signed and delivered by the Vendor to the Purchasing Division at the address listed below on or before the date and time of the bid opening. Any bid received by the Purchasing Division staff is considered to be in the possession of the Purchasing Division and will not be returned for any reason. The Purchasing Division will not accept bids, modification of bids, or addendum acknowledgment forms via e-mail. Acceptable delivery methods include electronic submission via wvOASIS, hand delivery, delivery by courier, or facsimile.

The bid delivery address is:  
Department of Administration, Purchasing Division  
2019 Washington Street East  
Charleston, WV 25305-0130

A bid that is not submitted electronically through wvOASIS should contain the information listed below on the face of the envelope or the bid may be rejected by the Purchasing Division.:

**SEALED BID:**

**BUYER:** Crystal Hustead  
**SOLICITATION NO.:** CRFQ DOT1900000128  
**BID OPENING DATE:** July 11, 2019  
**BID OPENING TIME:** 1:30 PM EST  
**FAX NUMBER:** 304-558-3970

The Purchasing Division may prohibit the submission of bids electronically through wvOASIS at its sole discretion. Such a prohibition will be contained and communicated in the wvOASIS system resulting in the Vendor's inability to submit bids through wvOASIS. Submission of a response to an Expression or Interest or Request for Proposal is not permitted in wvOASIS.

**For Request For Proposal ("RFP") Responses Only:** In the event that Vendor is responding to a request for proposal, the Vendor shall submit one original technical and one original cost proposal plus   n/a   convenience copies of each to the Purchasing Division at the address shown above. Additionally, the Vendor should identify the bid type as either a technical or cost proposal on the face of each bid envelope submitted in response to a request for proposal as follows:

**BID TYPE:** (This only applies to CRFP)

- Technical  
 Cost

**7. BID OPENING:** Bids submitted in response to this Solicitation will be opened at the location identified below on the date and time listed below. Delivery of a bid after the bid opening date and time will result in bid disqualification. For purposes of this Solicitation, a bid is considered delivered when confirmation of delivery is provided by wvOASIS (in the case of electronic submission) or when the bid is time stamped by the official Purchasing Division time clock (in the case of hand delivery).

**Bid Opening Date and Time:** July 11, 2019 at 1:30 PM EST

**Bid Opening Location:** Department of Administration, Purchasing Division  
2019 Washington Street East  
Charleston, WV 25305-0130

**8. ADDENDUM ACKNOWLEDGEMENT:** Changes or revisions to this Solicitation will be made by an official written addendum issued by the Purchasing Division. Vendor should acknowledge receipt of all addenda issued with this Solicitation by completing an Addendum Acknowledgment Form, a copy of which is included herewith. Failure to acknowledge addenda may result in bid disqualification. The addendum acknowledgement should be submitted with the bid to expedite document processing.

**9. BID FORMATTING:** Vendor should type or electronically enter the information onto its bid to prevent errors in the evaluation. Failure to type or electronically enter the information may result in bid disqualification.

**10. ALTERNATE MODEL OR BRAND:** Unless the box below is checked, any model, brand, or specification listed in this Solicitation establishes the acceptable level of quality only and is not intended to reflect a preference for, or in any way favor, a particular brand or vendor. Vendors may bid alternates to a listed model or brand provided that the alternate is at least equal to the model or brand and complies with the required specifications. The equality of any alternate being bid shall be determined by the State at its sole discretion. Any Vendor bidding an alternate model or brand should clearly identify the alternate items in its bid and should include manufacturer's specifications, industry literature, and/or any other relevant documentation demonstrating the equality of the alternate items. Failure to provide information for alternate items may be grounds for rejection of a Vendor's bid.

This Solicitation is based upon a standardized commodity established under W. Va. Code § 5A-3-61. Vendors are expected to bid the standardized commodity identified. Failure to bid the standardized commodity will result in your firm's bid being rejected.

**11. EXCEPTIONS AND CLARIFICATIONS:** The Solicitation contains the specifications that shall form the basis of a contractual agreement. Vendor shall clearly mark any exceptions, clarifications, or other proposed modifications in its bid. Exceptions to, clarifications of, or modifications of a requirement or term and condition of the Solicitation may result in bid disqualification.

**12. COMMUNICATION LIMITATIONS:** In accordance with West Virginia Code of State Rules §148-1-6.6, communication with the State of West Virginia or any of its employees regarding this Solicitation during the solicitation, bid, evaluation or award periods, except through the Purchasing Division, is strictly prohibited without prior Purchasing Division approval. Purchasing Division approval for such communication is implied for all agency delegated and exempt purchases.

**13. REGISTRATION:** Prior to Contract award, the apparent successful Vendor must be properly registered with the West Virginia Purchasing Division and must have paid the \$125 fee, if applicable.

**14. UNIT PRICE:** Unit prices shall prevail in cases of a discrepancy in the Vendor's bid.

**15. PREFERENCE:** Vendor Preference may be requested in purchases of motor vehicles or construction and maintenance equipment and machinery used in highway and other infrastructure projects. Any request for preference must be submitted in writing with the bid, must specifically identify the preference requested with reference to the applicable subsection of West Virginia Code § 5A-3-37, and should include with the bid any information necessary to evaluate and confirm the applicability of the requested preference. A request form to help facilitate the request can be found at:

<http://www.state.wv.us/admin/purchase/vrc/Venpref.pdf>.

**15A. RECIPROCAL PREFERENCE:** The State of West Virginia applies a reciprocal preference to all solicitations for commodities and printing in accordance with W. Va. Code § 5A-3-37(b). In effect, non-resident vendors receiving a preference in their home states, will see that same preference granted to West Virginia resident vendors bidding against them in West Virginia. A request form to help facilitate the request can be found at:

<http://www.state.wv.us/admin/purchase/vrc/Venpref.pdf>.

**16. SMALL, WOMEN-OWNED, OR MINORITY-OWNED BUSINESSES:** For any solicitations publicly advertised for bid, in accordance with West Virginia Code §5A-3-37(a)(7) and W. Va. CSR § 148-22-9, any non-resident vendor certified as a small, women-owned, or minority-owned business under W. Va. CSR § 148-22-9 shall be provided the same preference made available to any resident vendor. Any non-resident small, women-owned, or minority-owned business must identify itself as such in writing, must submit that writing to the Purchasing Division with its bid, and must be properly certified under W. Va. CSR § 148-22-9 prior to contract award to receive the preferences made available to resident vendors. Preference for a non-resident small, women-owned, or minority owned business shall be applied in accordance with W. Va. CSR § 148-22-9.

**17. WAIVER OF MINOR IRREGULARITIES:** The Director reserves the right to waive minor irregularities in bids or specifications in accordance with West Virginia Code of State Rules § 148-1-4.6.

**18. ELECTRONIC FILE ACCESS RESTRICTIONS:** Vendor must ensure that its submission in wvOASIS can be accessed and viewed by the Purchasing Division staff immediately upon bid opening. The Purchasing Division will consider any file that cannot be immediately accessed and viewed at the time of the bid opening (such as, encrypted files, password protected files, or incompatible files) to be blank or incomplete as context requires, and are therefore unacceptable. A vendor will not be permitted to unencrypt files, remove password protections, or resubmit documents after bid opening to make a file viewable if those documents are required with the bid. A Vendor may be required to provide document passwords or remove access restrictions to allow the Purchasing Division to print or electronically save documents provided that those documents are viewable by the Purchasing Division prior to obtaining the password or removing the access restriction.

**19. NON-RESPONSIBLE:** The Purchasing Division Director reserves the right to reject the bid of any vendor as Non-Responsible in accordance with W. Va. Code of State Rules § 148-1-5.3, when the Director determines that the vendor submitting the bid does not have the capability to fully perform, or lacks the integrity and reliability to assure good-faith performance.”

**20. ACCEPTANCE/REJECTION:** The State may accept or reject any bid in whole, or in part in accordance with W. Va. Code of State Rules § 148-1-4.5. and § 148-1-6.4.b.”

**21. YOUR SUBMISSION IS A PUBLIC DOCUMENT:** Vendor’s entire response to the Solicitation and the resulting Contract are public documents. As public documents, they will be disclosed to the public following the bid/proposal opening or award of the contract, as required by the competitive bidding laws of West Virginia Code §§ 5A-3-1 et seq., 5-22-1 et seq., and 5G-1-1 et seq. and the Freedom of Information Act West Virginia Code §§ 29B-1-1 et seq.

**DO NOT SUBMIT MATERIAL YOU CONSIDER TO BE CONFIDENTIAL, A TRADE SECRET, OR OTHERWISE NOT SUBJECT TO PUBLIC DISCLOSURE.**

Submission of any bid, proposal, or other document to the Purchasing Division constitutes your explicit consent to the subsequent public disclosure of the bid, proposal, or document. The Purchasing Division will disclose any document labeled “confidential,” “proprietary,” “trade secret,” “private,” or labeled with any other claim against public disclosure of the documents, to include any “trade secrets” as defined by West Virginia Code § 47-22-1 et seq. All submissions are subject to public disclosure without notice.

**22. INTERESTED PARTY DISCLOSURE:** West Virginia Code § 6D-1-2 requires that the vendor submit to the Purchasing Division a disclosure of interested parties to the contract for all contracts with an actual or estimated value of at least \$1 Million. That disclosure must occur on the form prescribed and approved by the WV Ethics Commission prior to contract award. A copy of that form is included with this solicitation or can be obtained from the WV Ethics Commission. This requirement does not apply to publicly traded companies listed on a national or international stock exchange. A more detailed definition of interested parties can be obtained from the form referenced above.

**23. WITH THE BID REQUIREMENTS:** In instances where these specifications require documentation or other information with the bid, and a vendor fails to provide it with the bid, the Director of the Purchasing Division reserves the right to request those items after bid opening and prior to contract award pursuant to the authority to waive minor irregularities in bids or specifications under W. Va. CSR § 148-1-4.6. This authority does not apply to instances where state law mandates receipt with the bid.



Purchasing Division  
 2019 Washington Street East  
 Post Office Box 50130  
 Charleston, WV 25305-0130

**State of West Virginia  
 Request for Quotation**

Proc Folder: 589305

Doc Description: 41K GWR SINGLE AXLE DUMP TRUCK (7019EC16)

Proc Type: Central Master Agreement

| Date Issued | Solicitation Closes    | Solicitation No         | Version |
|-------------|------------------------|-------------------------|---------|
| 2019-06-10  | 2019-07-11<br>13:30:00 | CRFQ 0803 DOT1900000128 | 1       |

**BID RECEIVING LOCATION**

BID CLERK  
 DEPARTMENT OF ADMINISTRATION  
 PURCHASING DIVISION  
 2019 WASHINGTON ST E  
 CHARLESTON WV 25305  
 US

**VENDOR**

Vendor Name, Address and Telephone Number:

Worldwide Equipment  
 5650 US Route 60 East  
 Huntington, WV 25705  
 304-345-2490

**FOR INFORMATION CONTACT THE BUYER**

Crystal G Husted  
 (304) 558-2402  
 crystal.g.husted@wv.gov

Signature X

FEIN # 45-1024981

DATE 7/16/19

All offers subject to all terms and conditions contained in this solicitation

**ADDITIONAL INFORMATION:**

THE WEST VIRGINIA PURCHASING DIVISION IS SOLICITING BIDS ON BEHALF OF THE WEST VIRGINIA DIVISION OF HIGHWAYS, DEPARTMENT OF TRANSPORTATION, TO ESTABLISH AN OPEN-END CONTRACT FOR A 41,000 GVWR SINGLE AXLE DUMP TRUCK WITH SNOW PLOW AND V-BOX SPREADER PER THE ATTACHED DOCUMENTS.

| INVOICE TO  |  | SHIP TO   |  |
|---|--|---|--|
| DIVISION OF HIGHWAYS<br>EQUIPMENT DIVISION RT 33<br>83 BRUSHY ROAD CROSSING, PO BOX 610<br>BUCKHANNON WV26201<br>US |  | DIVISION OF HIGHWAYS<br>EQUIPMENT DIVISION<br>83 BRUSHY FORK RD CROSSING<br>BUCKHANNON WV 26201<br>US |  |

| Line | Comm Ln Desc                 | Qty       | Unit Issue | Unit Price | Total Price |
|------|------------------------------|-----------|------------|------------|-------------|
| 1    | 41,000 GVWR Single Axle Dump | 120.00000 | EA         |            |             |

| Comm Code | Manufacturer | Specification | Model # |
|-----------|--------------|---------------|---------|
| 25101601  |              |               |         |

**Extended Description :**  
 41,000 GVWR Single Axle Dump Truck w/snowplow and V-Box Spreader

| INVOICE TO  |  | SHIP TO   |  |
|---|--|---|--|
| DIVISION OF HIGHWAYS<br>EQUIPMENT DIVISION RT 33<br>83 BRUSHY ROAD CROSSING, PO BOX 610<br>BUCKHANNON WV26201<br>US |  | DIVISION OF HIGHWAYS<br>EQUIPMENT DIVISION<br>83 BRUSHY FORK RD CROSSING<br>BUCKHANNON WV 26201<br>US |  |

| Line | Comm Ln Desc          | Qty       | Unit Issue | Unit Price | Total Price |
|------|-----------------------|-----------|------------|------------|-------------|
| 2    | FRONT 10FT. SNOW PLOW | 120.00000 | EA         |            |             |

| Comm Code | Manufacturer | Specification | Model # |
|-----------|--------------|---------------|---------|
| 25101601  |              |               |         |

**Extended Description :**  
 FRONT 10FT. SNOW PLOW

| INVOICE TO  |  | SHIP TO   |  |
|---|--|---|--|
| DIVISION OF HIGHWAYS<br>EQUIPMENT DIVISION RT 33<br>83 BRUSHY ROAD CROSSING, PO BOX 610<br>BUCKHANNON WV26201<br>US |  | DIVISION OF HIGHWAYS<br>EQUIPMENT DIVISION<br>83 BRUSHY FORK RD CROSSING<br>BUCKHANNON WV 26201<br>US |  |

| Line | Comm Ln Desc          | Qty       | Unit Issue | Unit Price | Total Price |
|------|-----------------------|-----------|------------|------------|-------------|
| 3    | FRONT 11FT. SNOW PLOW | 120.00000 | EA         |            |             |

| Comm Code | Manufacturer | Specification | Model # |
|-----------|--------------|---------------|---------|
| 25101601  |              |               |         |

**Extended Description :**  
FRONT 11FT. SNOW PLOW

| INVOICE TO  | SHIP TO   |
|---|---|
| DIVISION OF HIGHWAYS<br>EQUIPMENT DIVISION RT 33<br>83 BRUSHY ROAD CROSSING, PO BOX 610<br>BUCKHANNON WV26201<br>US | DIVISION OF HIGHWAYS<br>EQUIPMENT DIVISION<br>83 BRUSHY FORK RD CROSSING<br>BUCKHANNON WV 26201<br>US |

| Line | Comm Ln Desc   | Qty       | Unit Issue | Unit Price | Total Price |
|------|----------------|-----------|------------|------------|-------------|
| 4    | V-BOX SPREADER | 120.00000 | EA         |            |             |

| Comm Code | Manufacturer | Specification | Model # |
|-----------|--------------|---------------|---------|
| 25101601  |              |               |         |

**Extended Description :**  
V-BOX SPREADER

**SCHEDULE OF EVENTS**

| Line | Event                     | Event Date |
|------|---------------------------|------------|
| 1    | MANDATORY PRE-BID MEETING | 2019-06-25 |
| 2    | VENDOR QUESTION DEADLINE  | 2019-06-28 |



## **INSTRUCTIONS TO VENDORS SUBMITTING BIDS**

**1. REVIEW DOCUMENTS THOROUGHLY:** The attached documents contain a solicitation for bids. Please read these instructions and all documents attached in their entirety. These instructions provide critical information about requirements that if overlooked could lead to disqualification of a Vendor's bid. All bids must be submitted in accordance with the provisions contained in these instructions and the Solicitation. Failure to do so may result in disqualification of Vendor's bid.

**2. MANDATORY TERMS:** The Solicitation may contain mandatory provisions identified by the use of the words "must," "will," and "shall." Failure to comply with a mandatory term in the Solicitation will result in bid disqualification.

**3. PREBID MEETING:** The item identified below shall apply to this Solicitation.

A pre-bid meeting will not be held prior to bid opening

A NON-MANDATORY PRE-BID meeting will be held at the following place and time:

A MANDATORY PRE-BID meeting will be held at the following place and time:

Date and Time: June 25, 2019 at 10:00 AM EST

Location:

WV DOH Equipment Division  
83 Brushy Fork Road Crossing  
Buckhannon, WV 26201

All Vendors submitting a bid must attend the mandatory pre-bid meeting. Failure to attend the mandatory pre-bid meeting shall result in disqualification of the Vendor's bid. No one person attending the pre-bid meeting may represent more than one Vendor.

An attendance sheet provided at the pre-bid meeting shall serve as the official document verifying attendance. The State will not accept any other form of proof or documentation to verify attendance. Any person attending the pre-bid meeting on behalf of a Vendor must list on the attendance sheet his or her name and the name of the Vendor he or she is representing.

Additionally, the person attending the pre-bid meeting should include the Vendor's E-Mail address, phone number, and Fax number on the attendance sheet. It is the Vendor's responsibility to locate the attendance sheet and provide the required information. Failure to complete the attendance sheet as required may result in disqualification of Vendor's bid.

All Vendors should arrive prior to the starting time for the pre-bid. Vendors who arrive after the starting time but prior to the end of the pre-bid will be permitted to sign in, but are charged with knowing all matters discussed at the pre-bid.

Questions submitted at least five business days prior to a scheduled pre-bid will be discussed at the pre-bid meeting if possible. Any discussions or answers to questions at the pre-bid meeting are preliminary in nature and are non-binding. Official and binding answers to questions will be published in a written addendum to the Solicitation prior to bid opening.

**4. VENDOR QUESTION DEADLINE:** Vendors may submit questions relating to this Solicitation to the Purchasing Division. Questions must be submitted in writing. All questions must be submitted on or before the date listed below and to the address listed below in order to be considered. A written response will be published in a Solicitation addendum if a response is possible and appropriate. Non-written discussions, conversations, or questions and answers regarding this Solicitation are preliminary in nature and are nonbinding.

Submitted e-mails should have solicitation number in the subject line.

Question Submission Deadline: June 28, 2019 at 10:00 AM EST

Submit Questions to: Crystal Hustead  
2019 Washington Street, East  
Charleston, WV 25305  
Fax: (304) 558-4115 (Vendors should not use this fax number for bid submission)  
Email: [Crystal.G.Hustead@wv.gov](mailto:Crystal.G.Hustead@wv.gov)

**5. VERBAL COMMUNICATION:** Any verbal communication between the Vendor and any State personnel is not binding, including verbal communication at the mandatory pre-bid conference. Only information issued in writing and added to the Solicitation by an official written addendum by the Purchasing Division is binding.

**6. BID SUBMISSION:** All bids must be submitted electronically through wvOASIS or signed and delivered by the Vendor to the Purchasing Division at the address listed below on or before the date and time of the bid opening. Any bid received by the Purchasing Division staff is considered to be in the possession of the Purchasing Division and will not be returned for any reason. The Purchasing Division will not accept bids, modification of bids, or addendum acknowledgment forms via e-mail. Acceptable delivery methods include electronic submission via wvOASIS, hand delivery, delivery by courier, or facsimile.

The bid delivery address is:  
Department of Administration, Purchasing Division  
2019 Washington Street East  
Charleston, WV 25305-0130

A bid that is not submitted electronically through wvOASIS should contain the information listed below on the face of the envelope or the bid may be rejected by the Purchasing Division.:

**SEALED BID:**

**BUYER:** Crystal Husted  
**SOLICITATION NO.:** CRFQ DOT1900000128  
**BID OPENING DATE:** July 11, 2019  
**BID OPENING TIME:** 1:30 PM EST  
**FAX NUMBER:** 304-558-3970

The Purchasing Division may prohibit the submission of bids electronically through wvOASIS at its sole discretion. Such a prohibition will be contained and communicated in the wvOASIS system resulting in the Vendor's inability to submit bids through wvOASIS. Submission of a response to an Expression of Interest or Request for Proposal is not permitted in wvOASIS.

**For Request For Proposal ("RFP") Responses Only:** In the event that Vendor is responding to a request for proposal, the Vendor shall submit one original technical and one original cost proposal plus       n/a       convenience copies of each to the Purchasing Division at the address shown above. Additionally, the Vendor should identify the bid type as either a technical or cost proposal on the face of each bid envelope submitted in response to a request for proposal as follows:

**BID TYPE:** (This only applies to CRFP)

- Technical  
 Cost

**7. BID OPENING:** Bids submitted in response to this Solicitation will be opened at the location identified below on the date and time listed below. Delivery of a bid after the bid opening date and time will result in bid disqualification. For purposes of this Solicitation, a bid is considered delivered when confirmation of delivery is provided by wvOASIS (in the case of electronic submission) or when the bid is time stamped by the official Purchasing Division time clock (in the case of hand delivery).

**Bid Opening Date and Time:** July 11, 2019 at 1:30 PM EST

**Bid Opening Location:** Department of Administration, Purchasing Division  
2019 Washington Street East  
Charleston, WV 25305-0130

**8. ADDENDUM ACKNOWLEDGEMENT:** Changes or revisions to this Solicitation will be made by an official written addendum issued by the Purchasing Division. Vendor should acknowledge receipt of all addenda issued with this Solicitation by completing an Addendum Acknowledgment Form, a copy of which is included herewith. Failure to acknowledge addenda may result in bid disqualification. The addendum acknowledgement should be submitted with the bid to expedite document processing.

**9. BID FORMATTING:** Vendor should type or electronically enter the information onto its bid to prevent errors in the evaluation. Failure to type or electronically enter the information may result in bid disqualification.

**10. ALTERNATE MODEL OR BRAND:** Unless the box below is checked, any model, brand, or specification listed in this Solicitation establishes the acceptable level of quality only and is not intended to reflect a preference for, or in any way favor, a particular brand or vendor. Vendors may bid alternates to a listed model or brand provided that the alternate is at least equal to the model or brand and complies with the required specifications. The equality of any alternate being bid shall be determined by the State at its sole discretion. Any Vendor bidding an alternate model or brand should clearly identify the alternate items in its bid and should include manufacturer's specifications, industry literature, and/or any other relevant documentation demonstrating the equality of the alternate items. Failure to provide information for alternate items may be grounds for rejection of a Vendor's bid.

This Solicitation is based upon a standardized commodity established under W. Va. Code § 5A-3-61. Vendors are expected to bid the standardized commodity identified. Failure to bid the standardized commodity will result in your firm's bid being rejected.

**11. EXCEPTIONS AND CLARIFICATIONS:** The Solicitation contains the specifications that shall form the basis of a contractual agreement. Vendor shall clearly mark any exceptions, clarifications, or other proposed modifications in its bid. Exceptions to, clarifications of, or modifications of a requirement or term and condition of the Solicitation may result in bid disqualification.

**12. COMMUNICATION LIMITATIONS:** In accordance with West Virginia Code of State Rules §148-1-6.6, communication with the State of West Virginia or any of its employees regarding this Solicitation during the solicitation, bid, evaluation or award periods, except through the Purchasing Division, is strictly prohibited without prior Purchasing Division approval. Purchasing Division approval for such communication is implied for all agency delegated and exempt purchases.

**13. REGISTRATION:** Prior to Contract award, the apparent successful Vendor must be properly registered with the West Virginia Purchasing Division and must have paid the \$125 fee, if applicable.

**14. UNIT PRICE:** Unit prices shall prevail in cases of a discrepancy in the Vendor's bid.

**15. PREFERENCE:** Vendor Preference may be requested in purchases of motor vehicles or construction and maintenance equipment and machinery used in highway and other infrastructure projects. Any request for preference must be submitted in writing with the bid, must specifically identify the preference requested with reference to the applicable subsection of West Virginia Code § 5A-3-37, and should include with the bid any information necessary to evaluate and confirm the applicability of the requested preference. A request form to help facilitate the request can be found at:

<http://www.state.wv.us/admin/purchase/vrc/Venpref.pdf>.

**15A. RECIPROCAL PREFERENCE:** The State of West Virginia applies a reciprocal preference to all solicitations for commodities and printing in accordance with W. Va. Code § 5A-3-37(b). In effect, non-resident vendors receiving a preference in their home states, will see that same preference granted to West Virginia resident vendors bidding against them in West Virginia. A request form to help facilitate the request can be found at:

<http://www.state.wv.us/admin/purchase/vrc/Venpref.pdf>.

**16. SMALL, WOMEN-OWNED, OR MINORITY-OWNED BUSINESSES:** For any solicitations publicly advertised for bid, in accordance with West Virginia Code §5A-3-37(a)(7) and W. Va. CSR § 148-22-9, any non-resident vendor certified as a small, women-owned, or minority-owned business under W. Va. CSR § 148-22-9 shall be provided the same preference made available to any resident vendor. Any non-resident small, women-owned, or minority-owned business must identify itself as such in writing, must submit that writing to the Purchasing Division with its bid, and must be properly certified under W. Va. CSR § 148-22-9 prior to contract award to receive the preferences made available to resident vendors. Preference for a non-resident small, women-owned, or minority owned business shall be applied in accordance with W. Va. CSR § 148-22-9.

**17. WAIVER OF MINOR IRREGULARITIES:** The Director reserves the right to waive minor irregularities in bids or specifications in accordance with West Virginia Code of State Rules § 148-1-4.6.

**18. ELECTRONIC FILE ACCESS RESTRICTIONS:** Vendor must ensure that its submission in wvOASIS can be accessed and viewed by the Purchasing Division staff immediately upon bid opening. The Purchasing Division will consider any file that cannot be immediately accessed and viewed at the time of the bid opening (such as, encrypted files, password protected files, or incompatible files) to be blank or incomplete as context requires, and are therefore unacceptable. A vendor will not be permitted to unencrypt files, remove password protections, or resubmit documents after bid opening to make a file viewable if those documents are required with the bid. A Vendor may be required to provide document passwords or remove access restrictions to allow the Purchasing Division to print or electronically save documents provided that those documents are viewable by the Purchasing Division prior to obtaining the password or removing the access restriction.

**19. NON-RESPONSIBLE:** The Purchasing Division Director reserves the right to reject the bid of any vendor as Non-Responsible in accordance with W. Va. Code of State Rules § 148-1-5.3, when the Director determines that the vendor submitting the bid does not have the capability to fully perform, or lacks the integrity and reliability to assure good-faith performance.”

**20. ACCEPTANCE/REJECTION:** The State may accept or reject any bid in whole, or in part in accordance with W. Va. Code of State Rules § 148-1-4.5. and § 148-1-6.4.b.”

**21. YOUR SUBMISSION IS A PUBLIC DOCUMENT:** Vendor’s entire response to the Solicitation and the resulting Contract are public documents. As public documents, they will be disclosed to the public following the bid/proposal opening or award of the contract, as required by the competitive bidding laws of West Virginia Code §§ 5A-3-1 et seq., 5-22-1 et seq., and 5G-1-1 et seq. and the Freedom of Information Act West Virginia Code §§ 29B-1-1 et seq.

**DO NOT SUBMIT MATERIAL YOU CONSIDER TO BE CONFIDENTIAL, A TRADE SECRET, OR OTHERWISE NOT SUBJECT TO PUBLIC DISCLOSURE.**

Submission of any bid, proposal, or other document to the Purchasing Division constitutes your explicit consent to the subsequent public disclosure of the bid, proposal, or document. The Purchasing Division will disclose any document labeled “confidential,” “proprietary,” “trade secret,” “private,” or labeled with any other claim against public disclosure of the documents, to include any “trade secrets” as defined by West Virginia Code § 47-22-1 et seq. All submissions are subject to public disclosure without notice.

**22. INTERESTED PARTY DISCLOSURE:** West Virginia Code § 6D-1-2 requires that the vendor submit to the Purchasing Division a disclosure of interested parties to the contract for all contracts with an actual or estimated value of at least \$1 Million. That disclosure must occur on the form prescribed and approved by the WV Ethics Commission prior to contract award. A copy of that form is included with this solicitation or can be obtained from the WV Ethics Commission. This requirement does not apply to publicly traded companies listed on a national or international stock exchange. A more detailed definition of interested parties can be obtained from the form referenced above.

**23. WITH THE BID REQUIREMENTS:** In instances where these specifications require documentation or other information with the bid, and a vendor fails to provide it with the bid, the Director of the Purchasing Division reserves the right to request those items after bid opening and prior to contract award pursuant to the authority to waive minor irregularities in bids or specifications under W. Va. CSR § 148-1-4.6. This authority does not apply to instances where state law mandates receipt with the bid.

## **GENERAL TERMS AND CONDITIONS:**

**1. CONTRACTUAL AGREEMENT:** Issuance of a Award Document signed by the Purchasing Division Director, or his designee, and approved as to form by the Attorney General's office constitutes acceptance of this Contract made by and between the State of West Virginia and the Vendor. Vendor's signature on its bid signifies Vendor's agreement to be bound by and accept the terms and conditions contained in this Contract.

**2. DEFINITIONS:** As used in this Solicitation/Contract, the following terms shall have the meanings attributed to them below. Additional definitions may be found in the specifications included with this Solicitation/Contract.

**2.1. "Agency" or "Agencies"** means the agency, board, commission, or other entity of the State of West Virginia that is identified on the first page of the Solicitation or any other public entity seeking to procure goods or services under this Contract.

**2.2. "Bid" or "Proposal"** means the vendors submitted response to this solicitation.

**2.3. "Contract"** means the binding agreement that is entered into between the State and the Vendor to provide the goods or services requested in the Solicitation.

**2.4. "Director"** means the Director of the West Virginia Department of Administration, Purchasing Division.

**2.5. "Purchasing Division"** means the West Virginia Department of Administration, Purchasing Division.

**2.6. "Award Document"** means the document signed by the Agency and the Purchasing Division, and approved as to form by the Attorney General, that identifies the Vendor as the contract holder.

**2.7. "Solicitation"** means the official notice of an opportunity to supply the State with goods or services that is published by the Purchasing Division.

**2.8. "State"** means the State of West Virginia and/or any of its agencies, commissions, boards, etc. as context requires.

**2.9. "Vendor" or "Vendors"** means any entity submitting a bid in response to the Solicitation, the entity that has been selected as the lowest responsible bidder, or the entity that has been awarded the Contract as context requires.

**3. CONTRACT TERM; RENEWAL; EXTENSION:** The term of this Contract shall be determined in accordance with the category that has been identified as applicable to this Contract below:

**Term Contract**

**Initial Contract Term:** **Initial Contract Term:** This Contract becomes effective on \_\_\_\_\_  
Award and extends for a period of One (1) year(s).

**Renewal Term:** This Contract may be renewed upon the mutual written consent of the Agency, and the Vendor, with approval of the Purchasing Division and the Attorney General's office (Attorney General approval is as to form only). Any request for renewal should be delivered to the Agency and then submitted to the Purchasing Division thirty (30) days prior to the expiration date of the initial contract term or appropriate renewal term. A Contract renewal shall be in accordance with the terms and conditions of the original contract. Unless otherwise specified below, renewal of this Contract is limited to Three (3) successive one (1) year periods or multiple renewal periods of less than one year, provided that the multiple renewal periods do not exceed the total number of months available in all renewal years combined. Automatic renewal of this Contract is prohibited. Renewals must be approved by the Vendor, Agency, Purchasing Division and Attorney General's office (Attorney General approval is as to form only)

**Alternate Renewal Term** -- This contract may be renewed for \_\_\_\_\_ successive \_\_\_\_\_ year periods or shorter periods provided that they do not exceed the total number of months contained in all available renewals. Automatic renewal of this Contract is prohibited. Renewals must be approved by the Vendor, Agency, Purchasing Division and Attorney General's office (Attorney General approval is as to form only)

**Delivery Order Limitations:** In the event that this contract permits delivery orders, a delivery order may only be issued during the time this Contract is in effect. Any delivery order issued within one year of the expiration of this Contract shall be effective for one year from the date the delivery order is issued. No delivery order may be extended beyond one year after this Contract has expired.

**Fixed Period Contract:** This Contract becomes effective upon Vendor's receipt of the notice to proceed and must be completed within \_\_\_\_\_ days.

**Fixed Period Contract with Renewals:** This Contract becomes effective upon Vendor's receipt of the notice to proceed and part of the Contract more fully described in the attached specifications must be completed within \_\_\_\_\_ days. Upon completion of the work covered by the preceding sentence, the vendor agrees that maintenance, monitoring, or warranty services will be provided for \_\_\_\_\_ year(s) thereafter.

**One Time Purchase:** The term of this Contract shall run from the issuance of the Award Document until all of the goods contracted for have been delivered, but in no event will this Contract extend for more than one fiscal year.

**Other:** See attached.



**4. NOTICE TO PROCEED:** Vendor shall begin performance of this Contract immediately upon receiving notice to proceed unless otherwise instructed by the Agency. Unless otherwise specified, the fully executed Award Document will be considered notice to proceed.

**5. QUANTITIES:** The quantities required under this Contract shall be determined in accordance with the category that has been identified as applicable to this Contract below.

**Open End Contract:** Quantities listed in this Solicitation are approximations only, based on estimates supplied by the Agency. It is understood and agreed that the Contract shall cover the quantities actually ordered for delivery during the term of the Contract, whether more or less than the quantities shown.

**Service:** The scope of the service to be provided will be more clearly defined in the specifications included herewith.

**Combined Service and Goods:** The scope of the service and deliverable goods to be provided will be more clearly defined in the specifications included herewith.

**One Time Purchase:** This Contract is for the purchase of a set quantity of goods that are identified in the specifications included herewith. Once those items have been delivered, no additional goods may be procured under this Contract without an appropriate change order approved by the Vendor, Agency, Purchasing Division, and Attorney General's office.

**6. EMERGENCY PURCHASES:** The Purchasing Division Director may authorize the Agency to purchase goods or services in the open market that Vendor would otherwise provide under this Contract if those goods or services are for immediate or expedited delivery in an emergency. Emergencies shall include, but are not limited to, delays in transportation or an unanticipated increase in the volume of work. An emergency purchase in the open market, approved by the Purchasing Division Director, shall not constitute a breach of this Contract and shall not entitle the Vendor to any form of compensation or damages. This provision does not excuse the State from fulfilling its obligations under a One Time Purchase contract.

**7. REQUIRED DOCUMENTS:** All of the items checked below must be provided to the Purchasing Division by the Vendor as specified below.

**BID BOND (Construction Only):** Pursuant to the requirements contained in W. Va. Code § 5-22-1(c), All Vendors submitting a bid on a construction project shall furnish a valid bid bond in the amount of five percent (5%) of the total amount of the bid protecting the State of West Virginia. The bid bond must be submitted with the bid.

**PERFORMANCE BOND:** The apparent successful Vendor shall provide a performance bond in the amount of 100% of the contract. The performance bond must be received by the Purchasing Division prior to Contract award.

**LABOR/MATERIAL PAYMENT BOND:** The apparent successful Vendor shall provide a labor/material payment bond in the amount of 100% of the Contract value. The labor/material payment bond must be delivered to the Purchasing Division prior to Contract award.

In lieu of the Bid Bond, Performance Bond, and Labor/Material Payment Bond, the Vendor may provide certified checks, cashier's checks, or irrevocable letters of credit. Any certified check, cashier's check, or irrevocable letter of credit provided in lieu of a bond must be of the same amount and delivered on the same schedule as the bond it replaces. A letter of credit submitted in lieu of a performance and labor/material payment bond will only be allowed for projects under \$100,000. Personal or business checks are not acceptable. Notwithstanding the foregoing, West Virginia Code § 5-22-1 (d) mandates that a vendor provide a performance and labor/material payment bond for construction projects. Accordingly, substitutions for the performance and labor/material payment bonds for construction projects is not permitted.

**MAINTENANCE BOND:** The apparent successful Vendor shall provide a two (2) year maintenance bond covering the roofing system. The maintenance bond must be issued and delivered to the Purchasing Division prior to Contract award.

**LICENSE(S) / CERTIFICATIONS / PERMITS:** In addition to anything required under the Section of the General Terms and Conditions entitled Licensing, the apparent successful Vendor shall furnish proof of the following licenses, certifications, and/or permits prior to Contract award, in a form acceptable to the Purchasing Division.

The apparent successful Vendor shall also furnish proof of any additional licenses or certifications contained in the specifications prior to Contract award regardless of whether or not that requirement is listed above.

**8. INSURANCE:** The apparent successful Vendor shall furnish proof of the insurance identified by a checkmark below and must include the State as an additional insured on each policy prior to Contract award. The insurance coverages identified below must be maintained throughout the life of this contract. Thirty (30) days prior to the expiration of the insurance policies, Vendor shall provide the Agency with proof that the insurance mandated herein has been continued. Vendor must also provide Agency with immediate notice of any changes in its insurance policies, including but not limited to, policy cancelation, policy reduction, or change in insurers. The apparent successful Vendor shall also furnish proof of any additional insurance requirements contained in the specifications prior to Contract award regardless of whether or not that insurance requirement is listed in this section.

Vendor must maintain:

- Commercial General Liability Insurance** in at least an amount of: \$1,000,000.00-See below per occurrence.
- Automobile Liability Insurance** in at least an amount of: \$1,000,000.00 per occurrence.
- Professional/Malpractice/Errors and Omission Insurance** in at least an amount of: \_\_\_\_\_ per occurrence.
- Commercial Crime and Third Party Fidelity Insurance** in an amount of: \_\_\_\_\_ per occurrence.
- Cyber Liability Insurance** in an amount of: \_\_\_\_\_ per occurrence.
- Builders Risk Insurance** in an amount equal to 100% of the amount of the Contract.
- Pollution Insurance** in an amount of: \_\_\_\_\_ per occurrence.
- Aircraft Liability** in an amount of: \_\_\_\_\_ per occurrence.
- \*\*Please make insurance Certificate Holder to read as follows:**  
State of WV, 1900 Kanawha Blvd E, Bldg 5, Charleston, WV 25305
- State of WV must be listed as additional insured.**
- 
-

Notwithstanding anything contained in this section to the contrary, the Director of the Purchasing Division reserves the right to waive the requirement that the State be named as an additional insured on one or more of the Vendor's insurance policies if the Director finds that doing so is in the State's best interest.

**9. WORKERS' COMPENSATION INSURANCE:** The apparent successful Vendor shall comply with laws relating to workers compensation, shall maintain workers' compensation insurance when required, and shall furnish proof of workers' compensation insurance upon request.

**10. [Reserved]**

**11. LIQUIDATED DAMAGES:** This clause shall in no way be considered exclusive and shall not limit the State or Agency's right to pursue any other available remedy. Vendor shall pay liquidated damages in the amount specified below or as described in the specifications:

\_\_\_\_\_ for \_\_\_\_\_

Liquidated Damages Contained in the Specifications

**12. ACCEPTANCE:** Vendor's signature on its bid, or on the certification and signature page, constitutes an offer to the State that cannot be unilaterally withdrawn, signifies that the product or service proposed by vendor meets the mandatory requirements contained in the Solicitation for that product or service, unless otherwise indicated, and signifies acceptance of the terms and conditions contained in the Solicitation unless otherwise indicated.

**13. PRICING:** The pricing set forth herein is firm for the life of the Contract, unless specified elsewhere within this Solicitation/Contract by the State. A Vendor's inclusion of price adjustment provisions in its bid, without an express authorization from the State in the Solicitation to do so, may result in bid disqualification. Notwithstanding the foregoing, Vendor must extend any publicly advertised sale price to the State and invoice at the lower of the contract price or the publicly advertised sale price.

**14. PAYMENT IN ARREARS:** Payment in advance is prohibited under this Contract. Payment may only be made after the delivery and acceptance of goods or services. The Vendor shall submit invoices, in arrears.

**15. PAYMENT METHODS:** Vendor must accept payment by electronic funds transfer and P-Card. (The State of West Virginia's Purchasing Card program, administered under contract by a banking institution, processes payment for goods and services through state designated credit cards.)

**16. TAXES:** The Vendor shall pay any applicable sales, use, personal property or any other taxes arising out of this Contract and the transactions contemplated thereby. The State of West Virginia is exempt from federal and state taxes and will not pay or reimburse such taxes.

**17. ADDITIONAL FEES:** Vendor is not permitted to charge additional fees or assess additional charges that were not either expressly provided for in the solicitation published by the State of West Virginia or included in the unit price or lump sum bid amount that Vendor is required by the solicitation to provide. Including such fees or charges as notes to the solicitation may result in rejection of vendor's bid. Requesting such fees or charges be paid after the contract has been awarded may result in cancellation of the contract.

**18. FUNDING:** This Contract shall continue for the term stated herein, contingent upon funds being appropriated by the Legislature or otherwise being made available. In the event funds are not appropriated or otherwise made available, this Contract becomes void and of no effect beginning on July 1 of the fiscal year for which funding has not been appropriated or otherwise made available.

**19. CANCELLATION:** The Purchasing Division Director reserves the right to cancel this Contract immediately upon written notice to the vendor if the materials or workmanship supplied do not conform to the specifications contained in the Contract. The Purchasing Division Director may also cancel any purchase or Contract upon 30 days written notice to the Vendor in accordance with West Virginia Code of State Rules § 148-1-5.2.b.

**20. TIME:** Time is of the essence with regard to all matters of time and performance in this Contract.

**21. APPLICABLE LAW:** This Contract is governed by and interpreted under West Virginia law without giving effect to its choice of law principles. Any information provided in specification manuals, or any other source, verbal or written, which contradicts or violates the West Virginia Constitution, West Virginia Code or West Virginia Code of State Rules is void and of no effect.

**22. COMPLIANCE WITH LAWS:** Vendor shall comply with all applicable federal, state, and local laws, regulations and ordinances. By submitting a bid, Vendor acknowledges that it has reviewed, understands, and will comply with all applicable laws, regulations, and ordinances.

**SUBCONTRACTOR COMPLIANCE:** Vendor shall notify all subcontractors providing commodities or services related to this Contract that as subcontractors, they too are required to comply with all applicable laws, regulations, and ordinances. Notification under this provision must occur prior to the performance of any work under the contract by the subcontractor.

**23. ARBITRATION:** Any references made to arbitration contained in this Contract, Vendor's bid, or in any American Institute of Architects documents pertaining to this Contract are hereby deleted, void, and of no effect.

**24. MODIFICATIONS:** This writing is the parties' final expression of intent. Notwithstanding anything contained in this Contract to the contrary no modification of this Contract shall be binding without mutual written consent of the Agency, and the Vendor, with approval of the Purchasing Division and the Attorney General's office (Attorney General approval is as to form only). Any change to existing contracts that adds work or changes contract cost, and were not included in the original contract, must be approved by the Purchasing Division and the Attorney General's Office (as to form) prior to the implementation of the change or commencement of work affected by the change.

**25. WAIVER:** The failure of either party to insist upon a strict performance of any of the terms or provision of this Contract, or to exercise any option, right, or remedy herein contained, shall not be construed as a waiver or a relinquishment for the future of such term, provision, option, right, or remedy, but the same shall continue in full force and effect. Any waiver must be expressly stated in writing and signed by the waiving party.

**26. SUBSEQUENT FORMS:** The terms and conditions contained in this Contract shall supersede any and all subsequent terms and conditions which may appear on any form documents submitted by Vendor to the Agency or Purchasing Division such as price lists, order forms, invoices, sales agreements, or maintenance agreements, and includes internet websites or other electronic documents. Acceptance or use of Vendor's forms does not constitute acceptance of the terms and conditions contained thereon.

**27. ASSIGNMENT:** Neither this Contract nor any monies due, or to become due hereunder, may be assigned by the Vendor without the express written consent of the Agency, the Purchasing Division, the Attorney General's office (as to form only), and any other government agency or office that may be required to approve such assignments.

**28. WARRANTY:** The Vendor expressly warrants that the goods and/or services covered by this Contract will: (a) conform to the specifications, drawings, samples, or other description furnished or specified by the Agency; (b) be merchantable and fit for the purpose intended; and (c) be free from defect in material and workmanship.

**29. STATE EMPLOYEES:** State employees are not permitted to utilize this Contract for personal use and the Vendor is prohibited from permitting or facilitating the same.

**30. PRIVACY, SECURITY, AND CONFIDENTIALITY:** The Vendor agrees that it will not disclose to anyone, directly or indirectly, any such personally identifiable information or other confidential information gained from the Agency, unless the individual who is the subject of the information consents to the disclosure in writing or the disclosure is made pursuant to the Agency's policies, procedures, and rules. Vendor further agrees to comply with the Confidentiality Policies and Information Security Accountability Requirements, set forth in <http://www.state.wv.us/admin/purchase/privacy/default.html>.

**31. YOUR SUBMISSION IS A PUBLIC DOCUMENT:** Vendor's entire response to the Solicitation and the resulting Contract are public documents. As public documents, they will be disclosed to the public following the bid/proposal opening or award of the contract, as required by the competitive bidding laws of West Virginia Code §§ 5A-3-1 et seq., 5-22-1 et seq., and 5G-1-1 et seq. and the Freedom of Information Act West Virginia Code §§ 29B-1-1 et seq.

**DO NOT SUBMIT MATERIAL YOU CONSIDER TO BE CONFIDENTIAL, A TRADE SECRET, OR OTHERWISE NOT SUBJECT TO PUBLIC DISCLOSURE.**

Submission of any bid, proposal, or other document to the Purchasing Division constitutes your explicit consent to the subsequent public disclosure of the bid, proposal, or document. The Purchasing Division will disclose any document labeled "confidential," "proprietary," "trade secret," "private," or labeled with any other claim against public disclosure of the documents, to include any "trade secrets" as defined by West Virginia Code § 47-22-1 et seq. All submissions are subject to public disclosure without notice.

**32. LICENSING:** In accordance with West Virginia Code of State Rules § 148-1-6.1.e, Vendor must be licensed and in good standing in accordance with any and all state and local laws and requirements by any state or local agency of West Virginia, including, but not limited to, the West Virginia Secretary of State's Office, the West Virginia Tax Department, West Virginia Insurance Commission, or any other state agency or political subdivision. Obligations related to political subdivisions may include, but are not limited to, business licensing, business and occupation taxes, inspection compliance, permitting, etc. Upon request, the Vendor must provide all necessary releases to obtain information to enable the Purchasing Division Director or the Agency to verify that the Vendor is licensed and in good standing with the above entities.

**SUBCONTRACTOR COMPLIANCE:** Vendor shall notify all subcontractors providing commodities or services related to this Contract that as subcontractors, they too are required to be licensed, in good standing, and up-to-date on all state and local obligations as described in this section. Obligations related to political subdivisions may include, but are not limited to, business licensing, business and occupation taxes, inspection compliance, permitting, etc. Notification under this provision must occur prior to the performance of any work under the contract by the subcontractor.

**33. ANTITRUST:** In submitting a bid to, signing a contract with, or accepting a Award Document from any agency of the State of West Virginia, the Vendor agrees to convey, sell, assign, or transfer to the State of West Virginia all rights, title, and interest in and to all causes of action it may now or hereafter acquire under the antitrust laws of the United States and the State of West Virginia for price fixing and/or unreasonable restraints of trade relating to the particular commodities or services purchased or acquired by the State of West Virginia. Such assignment shall be made and become effective at the time the purchasing agency tenders the initial payment to Vendor.

**34. VENDOR CERTIFICATIONS:** By signing its bid or entering into this Contract, Vendor certifies (1) that its bid or offer was made without prior understanding, agreement, or connection with any corporation, firm, limited liability company, partnership, person or entity submitting a bid or offer for the same material, supplies, equipment or services; (2) that its bid or offer is in all respects fair and without collusion or fraud; (3) that this Contract is accepted or entered into without any prior understanding, agreement, or connection to any other entity that could be considered a violation of law; and (4) that it has reviewed this Solicitation in its entirety; understands the requirements, terms and conditions, and other information contained herein.

Vendor's signature on its bid or offer also affirms that neither it nor its representatives have any interest, nor shall acquire any interest, direct or indirect, which would compromise the performance of its services hereunder. Any such interests shall be promptly presented in detail to the Agency. The individual signing this bid or offer on behalf of Vendor certifies that he or she is authorized by the Vendor to execute this bid or offer or any documents related thereto on Vendor's behalf; that he or she is authorized to bind the Vendor in a contractual relationship; and that, to the best of his or her knowledge, the Vendor has properly registered with any State agency that may require registration.

**35. VENDOR RELATIONSHIP:** The relationship of the Vendor to the State shall be that of an independent contractor and no principal-agent relationship or employer-employee relationship is contemplated or created by this Contract. The Vendor as an independent contractor is solely liable for the acts and omissions of its employees and agents. Vendor shall be responsible for selecting, supervising, and compensating any and all individuals employed pursuant to the terms of this Solicitation and resulting contract. Neither the Vendor, nor any employees or subcontractors of the Vendor, shall be deemed to be employees of the State for any purpose whatsoever. Vendor shall be exclusively responsible for payment of employees and contractors for all wages and salaries, taxes, withholding payments, penalties, fees, fringe benefits, professional liability insurance premiums, contributions to insurance and pension, or other deferred compensation plans, including but not limited to, Workers' Compensation and Social Security obligations, licensing fees, etc. and the filing of all necessary documents, forms, and returns pertinent to all of the foregoing.

Vendor shall hold harmless the State, and shall provide the State and Agency with a defense against any and all claims including, but not limited to, the foregoing payments, withholdings, contributions, taxes, Social Security taxes, and employer income tax returns.

**36. INDEMNIFICATION:** The Vendor agrees to indemnify, defend, and hold harmless the State and the Agency, their officers, and employees from and against: (1) Any claims or losses for services rendered by any subcontractor, person, or firm performing or supplying services, materials, or supplies in connection with the performance of the Contract; (2) Any claims or losses resulting to any person or entity injured or damaged by the Vendor, its officers, employees, or subcontractors by the publication, translation, reproduction, delivery, performance, use, or disposition of any data used under the Contract in a manner not authorized by the Contract, or by Federal or State statutes or regulations; and (3) Any failure of the Vendor, its officers, employees, or subcontractors to observe State and Federal laws including, but not limited to, labor and wage and hour laws.



**37. PURCHASING AFFIDAVIT:** In accordance with West Virginia Code §§ 5A-3-10a and 5-22-1(i), the State is prohibited from awarding a contract to any bidder that owes a debt to the State or a political subdivision of the State, Vendors are required to sign, notarize, and submit the Purchasing Affidavit to the Purchasing Division affirming under oath that it is not in default on any monetary obligation owed to the state or a political subdivision of the state.

**38. ADDITIONAL AGENCY AND LOCAL GOVERNMENT USE:** This Contract may be utilized by other agencies, spending units, and political subdivisions of the State of West Virginia; county, municipal, and other local government bodies; and school districts (“Other Government Entities”), provided that both the Other Government Entity and the Vendor agree. Any extension of this Contract to the aforementioned Other Government Entities must be on the same prices, terms, and conditions as those offered and agreed to in this Contract, provided that such extension is in compliance with the applicable laws, rules, and ordinances of the Other Government Entity. A refusal to extend this Contract to the Other Government Entities shall not impact or influence the award of this Contract in any manner.

**39. CONFLICT OF INTEREST:** Vendor, its officers or members or employees, shall not presently have or acquire an interest, direct or indirect, which would conflict with or compromise the performance of its obligations hereunder. Vendor shall periodically inquire of its officers, members and employees to ensure that a conflict of interest does not arise. Any conflict of interest discovered shall be promptly presented in detail to the Agency.

**40. REPORTS:** Vendor shall provide the Agency and/or the Purchasing Division with the following reports identified by a checked box below:

Such reports as the Agency and/or the Purchasing Division may request. Requested reports may include, but are not limited to, quantities purchased, agencies utilizing the contract, total contract expenditures by agency, etc.

Quarterly reports detailing the total quantity of purchases in units and dollars, along with a listing of purchases by agency. Quarterly reports should be delivered to the Purchasing Division via email at [purchasing.requisitions@wv.gov](mailto:purchasing.requisitions@wv.gov).

**41. BACKGROUND CHECK:** In accordance with W. Va. Code § 15-2D-3, the Director of the Division of Protective Services shall require any service provider whose employees are regularly employed on the grounds or in the buildings of the Capitol complex or who have access to sensitive or critical information to submit to a fingerprint-based state and federal background inquiry through the state repository. The service provider is responsible for any costs associated with the fingerprint-based state and federal background inquiry.

After the contract for such services has been approved, but before any such employees are permitted to be on the grounds or in the buildings of the Capitol complex or have access to sensitive or critical information, the service provider shall submit a list of all persons who will be physically present and working at the Capitol complex to the Director of the Division of Protective Services for purposes of verifying compliance with this provision. The State reserves the right to prohibit a service provider’s employees from accessing sensitive or critical information or to be present at the Capitol complex based upon results addressed from a criminal background check.

Revised 01/24/2019

Service providers should contact the West Virginia Division of Protective Services by phone at (304) 558-9911 for more information.

**42. PREFERENCE FOR USE OF DOMESTIC STEEL PRODUCTS:** Except when authorized by the Director of the Purchasing Division pursuant to W. Va. Code § 5A-3-56, no contractor may use or supply steel products for a State Contract Project other than those steel products made in the United States. A contractor who uses steel products in violation of this section may be subject to civil penalties pursuant to W. Va. Code § 5A-3-56. As used in this section:

- a. "State Contract Project" means any erection or construction of, or any addition to, alteration of or other improvement to any building or structure, including, but not limited to, roads or highways, or the installation of any heating or cooling or ventilating plants or other equipment, or the supply of and materials for such projects, pursuant to a contract with the State of West Virginia for which bids were solicited on or after June 6, 2001.
- b. "Steel Products" means products rolled, formed, shaped, drawn, extruded, forged, cast, fabricated or otherwise similarly processed, or processed by a combination of two or more or such operations, from steel made by the open heath, basic oxygen, electric furnace, Bessemer or other steel making process. The Purchasing Division Director may, in writing, authorize the use of foreign steel products if:
- c. The cost for each contract item used does not exceed one tenth of one percent (.1%) of the total contract cost or two thousand five hundred dollars (\$2,500.00), whichever is greater. For the purposes of this section, the cost is the value of the steel product as delivered to the project; or
- d. The Director of the Purchasing Division determines that specified steel materials are not produced in the United States in sufficient quantity or otherwise are not reasonably available to meet contract requirements.

**43. PREFERENCE FOR USE OF DOMESTIC ALUMINUM, GLASS, AND STEEL:** In Accordance with W. Va. Code § 5-19-1 et seq., and W. Va. CSR § 148-10-1 et seq., for every contract or subcontract, subject to the limitations contained herein, for the construction, reconstruction, alteration, repair, improvement or maintenance of public works or for the purchase of any item of machinery or equipment to be used at sites of public works, only domestic aluminum, glass or steel products shall be supplied unless the spending officer determines, in writing, after the receipt of offers or bids, (1) that the cost of domestic aluminum, glass or steel products is unreasonable or inconsistent with the public interest of the State of West Virginia, (2) that domestic aluminum, glass or steel products are not produced in sufficient quantities to meet the contract requirements, or (3) the available domestic aluminum, glass, or steel do not meet the contract specifications. This provision only applies to public works contracts awarded in an amount more than fifty thousand dollars (\$50,000) or public works contracts that require more than ten thousand pounds of steel products.

The cost of domestic aluminum, glass, or steel products may be unreasonable if the cost is more than twenty percent (20%) of the bid or offered price for foreign made aluminum, glass, or steel products. If the domestic aluminum, glass or steel products to be supplied or produced in a

“substantial labor surplus area”, as defined by the United States Department of Labor, the cost of domestic aluminum, glass, or steel products may be unreasonable if the cost is more than thirty percent (30%) of the bid or offered price for foreign made aluminum, glass, or steel products. This preference shall be applied to an item of machinery or equipment, as indicated above, when the item is a single unit of equipment or machinery manufactured primarily of aluminum, glass or steel, is part of a public works contract and has the sole purpose or of being a permanent part of a single public works project. This provision does not apply to equipment or machinery purchased by a spending unit for use by that spending unit and not as part of a single public works project.

All bids and offers including domestic aluminum, glass or steel products that exceed bid or offer prices including foreign aluminum, glass or steel products after application of the preferences provided in this provision may be reduced to a price equal to or lower than the lowest bid or offer price for foreign aluminum, glass or steel products plus the applicable preference. If the reduced bid or offer prices are made in writing and supersede the prior bid or offer prices, all bids or offers, including the reduced bid or offer prices, will be reevaluated in accordance with this rule.

**44. INTERESTED PARTY SUPPLEMENTAL DISCLOSURE:** W. Va. Code § 6D-1-2 requires that for contracts with an actual or estimated value of at least \$1 million, the vendor must submit to the Agency a supplemental disclosure of interested parties reflecting any new or differing interested parties to the contract, which were not included in the original pre-award interested party disclosure, within 30 days following the completion or termination of the contract. A copy of that form is included with this solicitation or can be obtained from the WV Ethics Commission. This requirement does not apply to publicly traded companies listed on a national or international stock exchange. A more detailed definition of interested parties can be obtained from the form referenced above.

**DESIGNATED CONTACT:** Vendor appoints the individual identified in this Section as the Contract Administrator and the initial point of contact for matters relating to this Contract.

 Regional Sales Manager

(Name, Title)

Matt Cochran, Regional Sales Manager

(Printed Name and Title)

5650 US Route 60 East, Huntington, WV 25705

(Address)

304-345-2490 office, 304-208-2542 cell, 304-759-9807 fax

(Phone Number) / (Fax Number)

matt.cochran@thetruckpeople.com

(email address)

**CERTIFICATION AND SIGNATURE:** By signing below, or submitting documentation through wvOASIS, I certify that I have reviewed this Solicitation in its entirety; that I understand the requirements, terms and conditions, and other information contained herein; that this bid, offer or proposal constitutes an offer to the State that cannot be unilaterally withdrawn; that the product or service proposed meets the mandatory requirements contained in the Solicitation for that product or service, unless otherwise stated herein; that the Vendor accepts the terms and conditions contained in the Solicitation, unless otherwise stated herein; that I am submitting this bid, offer or proposal for review and consideration; that I am authorized by the vendor to execute and submit this bid, offer, or proposal, or any documents related thereto on vendor's behalf; that I am authorized to bind the vendor in a contractual relationship; and that to the best of my knowledge, the vendor has properly registered with any State agency that may require registration.

Worldwide Equipment

(Company)

 Regional Sales Manager

(Authorized Signature) (Representative Name, Title)

Matt Cochran, Regional Sales Manager

(Printed Name and Title of Authorized Representative)

7/16/19

(Date)

304-345-2490 office, 304-208-2542 cell, 304-759-9807 fax

(Phone Number) (Fax Number)

**ADDENDUM ACKNOWLEDGEMENT FORM**  
**SOLICITATION NO.: CRFQ DOT1900000128**

**Instructions:** Please acknowledge receipt of all addenda issued with this solicitation by completing this addendum acknowledgment form. Check the box next to each addendum received and sign below. Failure to acknowledge addenda may result in bid disqualification.

**Acknowledgment:** I hereby acknowledge receipt of the following addenda and have made the necessary revisions to my proposal, plans and/or specification, etc.

**Addendum Numbers Received:**

*(Check the box next to each addendum received)*

- |  |  |
|--|--|
| <input checked="" type="checkbox"/> Addendum No. 1 | <input type="checkbox"/> Addendum No. 6  |
| <input checked="" type="checkbox"/> Addendum No. 2 | <input type="checkbox"/> Addendum No. 7  |
| <input type="checkbox"/> Addendum No. 3            | <input type="checkbox"/> Addendum No. 8  |
| <input type="checkbox"/> Addendum No. 4            | <input type="checkbox"/> Addendum No. 9  |
| <input type="checkbox"/> Addendum No. 5            | <input type="checkbox"/> Addendum No. 10 |

I understand that failure to confirm the receipt of addenda may be cause for rejection of this bid. I further understand that any verbal representation made or assumed to be made during any oral discussion held between Vendor's representatives and any state personnel is not binding. Only the information issued in writing and added to the specifications by an official addendum is binding.

Worldwide Equipment

Company

  
Authorized Signature

7/16/19

Date

**NOTE:** This addendum acknowledgment should be submitted with the bid to expedite document processing.



Purchasing Division  
 2019 Washington Street East  
 Post Office Box 50130  
 Charleston, WV 25305-0130

State of West Virginia  
 Request for Quotation  
 19 — Highways

Proc Folder: 589305

Doc Description: ADDENDUM 1 41K GVWR SINGLE AXLE DUMP TRUCK (7019EC16)

Proc Type: Central Master Agreement

| Date Issued | Solicitation Closes    | Solicitation No         | Version |
|-------------|------------------------|-------------------------|---------|
| 2019-07-03  | 2019-07-17<br>13:30:00 | CRFQ 0803 DOT1900000128 | 2       |

**BID RECEIVING LOCATION**

BID CLERK  
 DEPARTMENT OF ADMINISTRATION  
 PURCHASING DIVISION  
 2019 WASHINGTON ST E  
 CHARLESTON WV 25305  
 US

**VENDOR**

Vendor Name, Address and Telephone Number:

Worldwide Equipment  
 5650 US Route 60 East  
 Huntington, WV 25705  
 304-345-2490

**FOR INFORMATION CONTACT THE BUYER**

Crystal G Hustead  
 (304) 558-2402  
 crystal.g.hustead@wv.gov

Signature X

FEIN # 45-1024981

DATE 7/16/19

All offers subject to all terms and conditions contained in this solicitation

**REQUEST FOR QUOTATION**  
**CRFQ DOT1900000128**  
**(Class 371) 41,000 GVWR Single Axle Dump Truck w/ Snow Plow and V-Box Spreader**

---

**SPECIFICATIONS**

- 1. PURPOSE AND SCOPE:** The West Virginia Purchasing Division is soliciting bids on behalf of the West Virginia Division of Highways, Department of Transportation to establish an open-end contract for a 41,000 GVWR Single Axle Dump Truck with Snow Plow and V-box spreader.
  
- 2. DEFINITIONS:** The terms listed below shall have the meanings assigned to them below. Additional definitions can be found in section 2 of the General Terms and Conditions.
  - 2.1 “Contract Item” or “Contract Items”** means the list of items identified in Section 3.1, below and on the Pricing Pages.
  
  - 2.2 “Pricing Pages”** means the schedule of prices, estimated order quantity, and totals contained in wvOASIS or attached hereto as **Exhibit A** and used to evaluate the Solicitation response.
  
  - 2.3 “Solicitation”** means the official notice of an opportunity to supply the State with goods or services that is published by the Purchasing Division.
  
  - 2.4 “G.V.W.”** means gross vehicle weight.
  
  - 2.5 “G.V.W.R”** means gross vehicle weight rating.
  
  - 2.6 “Lbs.”** means pounds.
  
  - 2.7 “BBC”** means Bumper to back of cab.
  
  - 2.8 “PSI”** means pounds per square inch.
  
  - 2.9 “WVDOH”** means West Virginia Division of Highways.
  
  - 2.10 “R.B.M.”** means Resisting Bending Moment.
  
  - 2.11 “PTO”** means power take off.
  
  - 2.12 “RPM”** means revolutions per minute.
  
  - 2.13 “APADS”** means Air conditioning protection and diagnostic system.
  
  - 2.14 “HP”** means horse power.

**REQUEST FOR QUOTATION**  
**CRFQ DOT1900000128**  
**(Class 371) 41,000 GVWR Single Axle Dump Truck w/ Snow Plow and V-Box Spreader**

---

- 2.15 “F” means Fahrenheit.
- 2.16 “FMVSS” means Federal Motor Vehicle Safety Standards. [www.fmvss.com](http://www.fmvss.com)
- 2.17 “CCA” means cold cranking amps.
- 2.18 “SAE” means Society of Automotive Engineers.
- 2.19 “ABS” means Antilock Braking System.
- 2.20 “ATC” means Automatic Traction Control
- 2.21 “MPH” means miles per hour.
- 2.22 “cu. ft.” means cubic feet.
- 2.23 “mm” means millimeter.
- 2.24 “cu. yd.” means cubic yard.
- 2.25 “I.D.” means inner diameter.
- 2.26 “GPM” means gallons per minute.
- 2.27 “LED” means light emitting diode.
- 2.28 “UV” means ultra violet.
- 2.29 “C” means Celsius.
- 2.30 “N.T.E.A” means National Truck Equipment Association. [www.ntea.com](http://www.ntea.com)
- 2.31 “ISO” means International Standards Organization.
- 2.32 “SO” means Standard Oil Resistant.
- 2.33 “NEMA” means National Electrical Manufacturer’s Association.
- 2.34 “dba” means decibels.
- 2.35 “PWM” means pulse-width modulated.
- 2.36 “NPT” means National Pipe Thread.
- 2.37 “TRT” means tamper resistant.



**REQUEST FOR QUOTATION  
CRFQ DOT1900000128**

**(Class 371) 41,000 GVWR Single Axle Dump Truck w/ Snow Plow and V-Box Spreader**

---

2.38 "cc" means close-coupled.

2.39 "CAN" means control area network.

2.40 "CIR" means Cubic Inches revolution.

2.41 "SS" means Stainless Steel

2.42 "OD" means Outside Diameter

2.43 "JIC" means Joint Industry Council

2.44 "mA" means milliamps

2.45 "AASHTO" means American Association of State Highway and Transportation.  
[www.transportation.org](http://www.transportation.org)

2.46 "CA" means cab to axle.

2.47 "CT" means cab to trunnion.

2.48 "12 VDC" means 12 volt direct current.

2.49 "OEM" means Original Equipment Manufacturer.

2.50 "BTU" means British Thermal Unit.

2.51 "USB" means Universal Serial Bus.

2.52 "WC" means tungsten carbide.

2.53 "371 Class" for internal use only.

**3. GENERAL REQUIREMENTS:**

**3.1 Contract Items and Mandatory Requirements:** Vendor shall provide Agency with the Contract Items listed below on an open-end and continuing basis. Contract Items must meet or exceed the mandatory requirements as shown below.

**3.1.1 Cab and Chassis:**

3.1.1.1 The GVWR rating shall be 41,000 Lbs., minimum rating.

**REQUEST FOR QUOTATION  
CRFQ DOT1900000128**

**(Class 371) 41,000 GVWR Single Axle Dump Truck w/ Snow Plow and V-Box Spreader**

---

**3.1.1.2 Cab to Axle Dimension:** Shall be 84 inches minimum usable. (Back of cab to centerline of axle).

**3.1.1.3** The after-frame length shall be 45 inches minimum. (Centerline of Axle to back of frame).

**3.1.1.4** The unit specified herein and offered shall be manufactured on or after January 1, 2020 and must be clearly identified and marked with date of manufacture.

**3.1.2 Wheelbase:**

**3.1.2.1** Shall be 150 inches minimum and shall be set forward axle design for snowplow applications.

**3.1.2.2** Wheelbase and CA dimension shall be adjusted to provide legal weight distribution.

**3.1.2.2.1** Chassis OEM and body company are responsible for coordinating the correct CA calculations.

**3.1.3 Frame and Front Bumper:**

**3.1.3.1** The manufacturer shall provide a frame that meets or exceeds all Federal requirements for G.V.W.R. specified that extends forward beyond the grille a minimum of 12 inches.

**3.1.3.2** Frame material shall be single frame minimum 120,000 PSI yield strength. Frame extension shall be "parent rail" material. Bolt on extension not acceptable.

**3.1.3.3** R.B.M: Minimum 2,500,600 Ins./Lb. per rail. An integral frame and frame extension is mandatory.

**3.1.3.4** Frame shall have two (2) front frame mounted tow hooks.

**3.1.3.5** Front bumper shall be formed out of .177- inch minimum roll steel front bumper with swept back ends.

**3.1.3.6** Bumper shall be painted black in color, paint type base coat clear urethane.

**3.1.3.7** Bumper shall not interfere with factory headlights.

**REQUEST FOR QUOTATION**  
**CRFQ DOT1900000128**  
**(Class 371) 41,000 GVWR Single Axle Dump Truck w/ Snow Plow and V-Box Spreader**

---

**3.1.3.8** Bumper shall have mesh type aluminum tread plate/grating between hood, bumper and fender.

**3.1.3.9** Bumper shall have cutouts to access front tow hooks.

**3.1.4 Cab:**

**3.1.4.1** The cab shall be manufacturers' galvanized steel, galvanized steel or aluminum.

**3.1.4.2** Hood shall be fiberglass, one-piece tilting hood, fenders shall be part of tilting hood.

**3.1.4.3** Grille shall be fixed.

**3.1.4.4** Hood shall not come in contact with plow frame.

**3.1.4.5** Must allow access to engine with hood open.

**3.1.4.5.1** Access to front-end hood tilt handle shall not be blocked.

**3.1.4.6** Cab shall have rear air bag suspension if available by manufacturer, factory installed.

**3.1.4.7** Cab shall have air ride high back seats with folding armrest, cloth, with lumbar, with integrated cushion extensions, with forward and rear cushion tilt – Driver and Passenger side.

**3.1.4.8** Cab Interior Floor Mat shall have rubber floor mat throughout cab area with non-absorbent backing under the mat.

**3.1.4.9** Cab shall have highest output available by manufacturers, Air Conditioning with/integral heater and defroster and minimum of one (1) replaceable fresh air filter.

**3.1.4.10** Windshield Wipers shall be winter blade type with heaviest arms, linkages and motor available by manufacture.

**3.1.4.11** Wipers shall be minimum of 2 speeds, electric with intermittent feature.

**REQUEST FOR QUOTATION  
CRFQ DOT1900000128**

**(Class 371) 41,000 GVWR Single Axle Dump Truck w/ Snow Plow and V-Box Spreader**

---

**3.1.4.12** Washer system shall be electric with largest capacity reservoir available by manufacturer.

**3.1.4.13** Windshield wipers shall be automatically forced to slowest intermittent speed when the park brake is set, and wipers left on for predetermined amount of time.

**3.1.4.14** Headlights (low beam) and tail lights shall turn on automatically when wipers are activated.

**3.1.5 Instruments: The following instruments shall be contained in the truck cab.**

**3.1.5.1** Coolant gauge and oil pressure gauge shall have both dial type readout and either an audible or visual alarm to warn operator when safe operating conditions are exceeded.

**3.1.5.2** Voltmeter or Ammeter gauge.

**3.1.5.3** Engine RPM Tachometer.

**3.1.5.4** Speedometer with odometer and a dual speedometer lead to interface with the ground speed spreader control system.

**3.1.5.5** Primary Air Pressure Gauge/Auxiliary Air Pressure Gauge.

**3.1.5.6** Air filter restriction indicator gauge.

**3.1.5.7** Engine hour meter (Controlled by engine operation, not by key switch).

**3.1.5.8** Must have Fuel level gauge and diesel exhaust fluid gauge.

**3.1.5.9** Manufacturers best sound/weather insulation package for proposed cab.

**3.1.5.10** Cab shall have transmission temperature gauge.

**3.1.6 Accessories: The following accessories must be included with the truck cab & chassis:**

**REQUEST FOR QUOTATION  
CRFQ DOT1900000128**

**(Class 371) 41,000 GVWR Single Axle Dump Truck w/ Snow Plow and V-Box Spreader**

---

- 3.1.6.1** Cab shall have minimum of one air horn cab mounted or under hood mounted with snow shield.
- 3.1.6.2** Right side and left side cab mirrors: Cab mirrors shall be west coast type 7 inches wide minimum x 15 ¾ - inches high minimum, power adjustable with fore and after breakaway arms. 8 inches minimum convex spot mirror. Both mirrors must be heated type with all arms, hardware and fasteners stainless steel.
- 3.1.6.3** Shall have down view mirror, right hand side only.
- 3.1.6.4** Grab handles shall be supplied on all cab entry locations. Three points of contact shall be achievable at all cab entry locations.
- 3.1.6.5** The cab shall have the manufacturer's standard tinted safety glass installed throughout the front, sides and rear.
- 3.1.6.6** The front windshield shall be heated.
- 3.1.6.7** The cab shall have dual power windows.
- 3.1.6.8** The cab shall have manufacturer's standard AM/FM/Weather Band/Clock with wireless connectivity.
- 3.1.6.9** Mud flaps and/or fender extensions shall be provided and installed on the cab behind the left and right front tires.
- 3.1.6.10** Cab shall contain a DOT approved emergency triangle warning kit.
- 3.1.6.11** The cab shall have a mounted 5 lbs. maximum fire extinguisher with A, B and C rating.
- 3.1.6.12** Cab shall have clear or smoked hood mounted air deflector, manufacturer's full width for truck model bid.
- 3.1.6.13** Cab shall have six (4) additional switches.
- 3.1.6.14** Cab shall have OEM PTO switch.
- 3.1.6.15** Accessories not indicated above but are included in the manufacturer's standard model bid must be provided.

**REQUEST FOR QUOTATION  
CRFQ DOT1900000128**

**(Class 371) 41,000 GVWR Single Axle Dump Truck w/ Snow Plow and V-Box Spreader**

---

**3.1.6.16** Vendor shall provide a 15-amp minimum hookup for two-way radios.

**3.1.7 Engine:**

**3.1.7.1** The engine shall be a diesel powered Turbocharged.

**3.1.7.1.1** 8.9-liter minimum.

**3.1.7.1.2** 6-cylinder minimum.

**3.1.7.1.3** Minimum HP- 360

**3.1.7.1.4** Minimum Peak Torque 1150 LB/FT

**3.1.7.1.5** Engine must meet final tier 4 emissions.

**3.1.7.1.6** Engine must have been in production and field use for a minimum of one (1) years in the U.S.

**3.1.7.2** Engine Compression Brake: Must be full engine compression brake minimum 3 stages with selector switch and on/off power switch and shall be dash mounted.

**3.1.7.2.1** Chassis brake lights shall turn on when engine brake is activated.

**3.1.7.3** Engine oil pan shall be sprayed with corrosion resistant coating.

**3.1.7.4** Air filter shall be largest volume available offered by manufacturer for severe duty conditions.

**3.1.7.5** Air Intake shall be equipped with snow valve or equal driver controlled inside/outside engine air intake for air cleaner.

**3.1.7.6** Engine shall have a Phillips-Temro or equal 1000watt/120-volt block heater with corrosion resistant weather proof receptacle housing located on left side of cab. The engine block heater and the fuel water separator overnight heater shall be powered via the same electrical connector.

**REQUEST FOR QUOTATION  
CRFQ DOT1900000128**

**(Class 371) 41,000 GVWR Single Axle Dump Truck w/ Snow Plow and V-Box Spreader**

---

**3.1.7.7** Engine shall have a Davco fuel pro 382 or equal water separator with 120-volt overnight heater and a 12-volt pre-heater. The engine fuel water overnight heater and the block heater shall be powered via the same electrical connection.

**3.1.8 Exhaust System:**

**3.1.8.1** Manufacturers standard vertical side of cab exhaust for model bid.

**3.1.8.2** Exhaust system shall not interfere with the dump body or equipment.

**3.1.8.3** Exhaust shall be stainless steel or aluminized pipe with all clamps and fasteners being stainless steel.

**3.1.8.4** Muffler and tailpipe shall be shielded to protect personnel when entering and exiting the cab.

**3.1.8.5** The shield shall be 180 degrees to 360 degrees and shall be of non-rustable material such as stainless steel or aluminum.

**3.1.9 Cooling System:**

**3.1.9.1** The largest available engine cooling capacity, factory compatible with engine and transmission referenced for continuous high engine output under extreme temperatures and/or operating conditions due to prolonged snow plowing operations in low gear.

**3.1.9.2** Cooling system shall be fitted with provisions for visually monitoring coolant without necessitating removal of the cap from the radiator or expansion tank.

**3.1.9.3** Antifreeze shall be extended life with a minimum of -34 degrees and shall meet all applicable Environmental Protection Agency (EPA) requirements.

**3.1.9.4** A non-charged spin-on coolant filter shall be installed if required by engine manufacturer.

**REQUEST FOR QUOTATION  
CRFQ DOT1900000128**

**(Class 371) 41,000 GVWR Single Axle Dump Truck w/ Snow Plow and V-Box Spreader**

---

**3.1.9.5** Radiator shall have stainless steel or corrosion resistant screen guard to protect radiator from foreign objects.

**3.1.9.6** All engine coolant piping must be stainless steel or aluminized.

**3.1.9.7** All coolant hoses shall be gates blue strip or equal.

**3.1.9.8** All hose clamps shall be constant tension type stainless steel, power grip or equal.

**3.1.10 Fuel Tanks:**

**3.1.10.1** Fuel Tanks must comply with FMVSS.

**3.1.10.2** Shall have one aluminum 90-gallon minimum fuel tank, shall be mounted on left side under cab, frame mounted with stainless steel mounting straps.

**3.1.10.3** Must have driver and passenger entrance steps, stainless steel or aluminum grated self-cleaning safety steps.

**3.1.11 Transmission Allison 3000 RDS or equal.**

**3.1.11.1** Transmission shall be fully automatic with torque converter.

**3.1.11.2** Transmission shall have provision for PTO.

**3.1.11.3** Shall have a transmission shift pad or shift lever with oil life monitor; filter life monitor and transmission health monitor, lighted and dash or console mounted.

**3.1.11.4** Transmission shall have largest available approved transmission cooler for transmission provided. All cooler hard lines shall be corrosion resistant.

**3.1.11.5** Transmission (TCM) Transmission Control Module shall be located inside cab.

**3.1.12 Driveline:**

**3.1.12.1** Driveline must be compatible to engine, drivetrain and transmission torque with sealed joints SPL-170XL spicer



**REQUEST FOR QUOTATION**  
**CRFQ DOT1900000128**  
**(Class 371) 41,000 GVWR Single Axle Dump Truck w/ Snow Plow and V-Box Spreader**

---

driveline or equal. If required by manufacturer, driveline shall have center carrier bearing.

**3.1.13 Rear Axle:**

**3.1.13.1** Rear axle shall be a minimum rating of 23,000 lbs. with locking differential dash controlled.

**3.1.13.2** Rear axle shall have an extended breather tube to prevent buildup from entering axle housing.

**3.1.13.3** Axle ratio and top MPH parameters shall be determined at pre-build meeting.

**3.1.14 Rear Suspension:**

**3.1.14.1** Shall have multi-leaf spring type rated for 23,000 lb. minimum capacity with helper.

**3.1.15 Front Axle:**

**3.1.15.1** Front axle shall be set forward. OEM Nominal dimension for the proposed model (excludes front frame extension) shall not exceed 36-inches from the bumper to the center of the front axle for weight distribution of front mounted equipment.

**3.1.15.2** Shall have minimum capacity of 18,000 lbs.

**3.1.15.3** Shall have right and left shock absorbers rated for 18,000 lb. minimum, axle.

**3.1.16 Front Suspension:**

**3.1.16.1** Shall have 9,000 lb. minimum capacity at ground on each front spring, total spring capacity 18,000 lb. minimum.

**3.1.16.2** The front spring pins or bearing/bushings shall be furnished with 360-degree grease grooves to insure adequate lubricant penetration and/or maintenance free front spring bushings.

**REQUEST FOR QUOTATION**  
**CRFQ DOT1900000128**  
**(Class 371) 41,000 GVWR Single Axle Dump Truck w/ Snow Plow and V-Box Spreader**

---

**3.1.16.3** Spring hangers shall be heaviest available by manufacturer.

**3.1.17 Steering:**

**3.1.17.1** Shall have steering gear that meets or exceeds 18,000lbs. front axle.

**3.1.17.2** Steering column shall be tilt and/telescopic.

**3.1.18 Brakes and Air System:**

**3.1.18.1** Brakes shall be full air, with manufacturer's ABS.

**3.1.18.2** Air Compressor shall be a minimum of 18 CFM.

**3.1.18.2.1** Shall have air dryer compatible with heater and spin on cartridge filter.

**3.1.18.3** Rear parking brakes shall be spring loaded.

**3.1.18.4** Rear brake chambers shall be mounted to provide clearance for tire chains and backing into bituminous paving machines. Factory installed only.

**3.1.18.5** Brake chambers shall be sealed type and housings shall be e-coated for corrosion or equal.

**3.1.18.6** Air tanks shall be frame mounted aluminum or stainless steel with drain valve.

**3.1.18.7** Unit shall be equipped with hand control valve, tractor protection valve, with swivel glad hands at rear of truck to enable unit to pull air operated equipment trailer.

**3.1.18.8** Shall have low warning air pressure warning light and buzzer.

**3.1.18.9** Front brakes: shall be full air powered disc brakes or drum brakes.

**3.1.18.10** Rear brakes: shall be full air powered disc brakes or drum brakes

**REQUEST FOR QUOTATION  
CRFQ DOT1900000128**

**(Class 371) 41,000 GVWR Single Axle Dump Truck w/ Snow Plow and V-Box Spreader**

---

**3.1.18.11** Front and Rear brakes shall have automatic slack adjuster with stainless steel yoke pins.

**3.1.18.12** Vehicle shall be equipped with a safety/alarm system to warn operator when leaving the vehicle without setting the park brake.

**3.1.18.12.1** The parking brake alarm will sound the electric horn in a repetitive manner when vehicles park brake is not set, with ignition off and door is open

**3.1.19 Trailer Tow Package shall include the following:**

**3.1.19.1** A 49,000 LB. minimum capacity swivel style pintle hook shall be installed at 32 inches maximum above ground on a ¾ inch thick minimum pintle plate properly supported to frame and cross members.

**3.1.19.1.1** Shall include two one-inch D-rings.

**3.1.19.2** The truck shall be equipped with a full trailer air brake package.

**3.1.19.2.1** The glad hand connections shall be located at the rear of truck and located with red (emergency) on driver's side and blue (service) on passenger side.

**3.1.19.2.2** Glad hands shall be swivel design.

**3.1.19.3** Truck shall be equipped with air actuated electric trailer brake controller, mounted in cab.

**3.1.19.4** There shall be two 7-poll female trailer connectors with round brass inserts mounted in a corrosion resistant housing.

**3.1.19.4.1** One shall be for trailer lighting with electric brakes and one for trailer lighting with air brakes.

**3.1.19.4.2** Both connectors shall be labeled.

**REQUEST FOR QUOTATION  
CRFQ DOT1900000128**

**(Class 371) 41,000 GVWR Single Axle Dump Truck w/ Snow Plow and V-Box Spreader**

---

**3.1.20 Tires and Wheels:**

**3.1.20.1** The truck shall be equipped with front and rear hub piloted aluminum wheels Alcoa or equal with corrosion coating.

**3.1.20.2** Wheels front and rear shall have correct rating for the GVWR of truck.

**3.1.20.3** Front steer tires shall be 315/80/R22.5 with correct load range and ply rating for the GVWR of truck Goodyear brand or equal.

**3.1.20.4** Rear drive tires shall be a mud and snow tread 11R/ 22.5 with correct load range and ply rating for the GVWR of truck Goodyear brand or equal.

**3.1.20.5** The dual rear wheel/tire assembly shall have clearance between the tires, which permits the use of dual tire chain.

**3.1.20.6** Wheel guard separators shall be installed between wheels and brake drum front and rear.

**3.1.20.7** All tires shall be radials.

**3.1.21 Electrical System & Lighting:**

**3.1.21.1** Lighting system shall have an exterior light test system to aid driver with safety pre-trip inspections.

**3.1.21.1.1** Engaging light inspection switch will sequentially flash all exterior vehicle lights, except back up lights while operator completes safety inspection.

**3.1.21.2** Shall have manufacturer's 12-volt negative ground system with manufacturer's radio interference suppression.

**3.1.21.3 Batteries:**

**A.** Shall have minimum of two 12 volt All Glass Mat (AGM) deep cycle batteries stainless steel stud type, with a battery reserve of 200 amp-hours minimum.

**REQUEST FOR QUOTATION  
CRFQ DOT1900000128**

**(Class 371) 41,000 GVWR Single Axle Dump Truck w/ Snow Plow and V-Box Spreader**

---

**B. Shall have one minimum, ultra-capacitor engine module for class 8 trucks, shall be group 31 size, stainless steel stud type, minimum 1800 CCA.**

**C. See No Idle Heat and Power System Section 3.1.23 for explanation of battery section.**

**D. Batteries shall have aluminum battery box with plastic or aluminum lid with battery pad for vibration and corrosion.**

**3.1.21.4 Alternator capacity shall be 160 AMPS minimum with internal regulator.**

**3.1.21.5 Cab and chassis must have best available wiring shield available by manufacturer.**

**3.1.21.6 The cab and chassis shall have:**

**A. Day time running lights.**

**B. LED cab marker lights.**

**C. Halogen head lamps, Headlamps (low beam) shall turn on automatically when wipers are activated.**

**D. LED Park, brake and turn signals.**

**E. 1-pair of Halogen Driving Lights mounted with plow lights Hella brand or equal.**

**3.1.21.7 Salt spreader lighting package:**

**Successful vendor shall supply a 7-pole corrosion resistant disconnect plug at rear of truck to operate the following lights on truck mounted chemical spreader:**

**A. Two (2) 4-inch minimum sealed beam work lights.**

**B. Left and right combination brake/turn and tail lights LED.**

**C. Four LED strobe warning lights.**

**REQUEST FOR QUOTATION  
CRFQ DOT1900000128**

**(Class 371) 41,000 GVWR Single Axle Dump Truck w/ Snow Plow and V-Box Spreader**

---

**3.1.21.8** Snowplow LED heated headlights with LED park and turn signals for snowplowing application shall be shock mounted on fender of truck with stainless steel brackets Truck-Lite brand or equal.

**3.1.22 Paint, Decals and Logos:**

**3.1.22.1** The cab exterior and interior paint shall be base coat clear coat urethane paint yellow/gold, DuPont F9885, Sherwin Williams 73266, Sikkens 4017, PPG 85246 or Napa 73266 shade only.

**3.1.22.2** The cab grill shall be manufacturer's standard stainless steel or impact resistant noncorrosive composite material.

**3.1.22.3** The cab shall not be painted over top another finished color.

**3.1.22.4** Chassis paint shall be urethane base, chassis color black.

**3.1.23 No Idle Heat and Power System:**

**3.1.23.1** The No Idle heat and Power System shall do and include the following:

- A.** The system shall be controlled by a touchscreen(user interface) Touchscreen will control electrical circuits specified in document E.
- B.** The system shall provide a dash display of battery voltage an audible alert when battery voltage needs to be replenished, and automatically disconnect the loads at a predetermined low voltage setting with use of a low voltage disconnect.
- C.** Shall power loads during no-idle conditions with deep cycle AGM batteries for a minimum of 6 hours.
- D.** Shall provide a minimum of 17,000 BTUs of heat for cab and engine.

**REQUEST FOR QUOTATION  
CRFQ DOT1900000128**

**(Class 371) 41,000 GVWR Single Axle Dump Truck w/ Snow Plow and V-Box Spreader**

---

E. Shall provide electrical power to heater blower motor and controls, parking lights, AM/FM radio weather band with wireless connectivity, WVDOH state 2way radio and emergency/ strobe lighting with key in auxiliary position.

F. Truck shall use electric start module for engine starting.

G. All AGM batteries and electronic start module shall be group 31 and fit in the OEM battery tray without modifications

**3.2 Dump Body:**

**3.2.1 Stainless Steel Dump Body:** Dump Body to be minimum 201 stainless steel cross member-less. Smooth under side type, suitable for use by WVDOH in severe duty street and highway maintenance including snow and ice control with external mounted cylinder.

**3.2.1.1** Dump Body inside minimum length 126 inches.

**3.2.1.2** Dump Body inside minimum width 85 inches, outside maximum width 96 inches.

**3.2.1.3** Dump Body side height (from bottom of floor to top of top rail) minimum 30 inches high.

**3.2.1.4** Tailgate shall be 38" high minimum.

**3.2.1.5** Head sheet shall be minimum 52" high.

**3.2.1.6** Sides, head sheet and tailgate shall be 7gauge minimum Type 201 Stain-less steel.

**3.2.1.7** Floor shall be minimum one-piece 1/4" thick abrasion resistant with a minimum tensile of 180,000, minimum yield 145,000 and minimum Brinell of 400, with both side radiuses built into the floor.

**3.2.1.8** Bed sides shall be 7gauge minimum, 201 stainless steel.

**3.2.1.9** Top rails are to be 4" x 5" minimum seamless, sloping (dirt/salt shedding) and boxed for added strength.

## REQUEST FOR QUOTATION

CRFQ DOT1900000128

(Class 371) 41,000 GVWR Single Axle Dump Truck w/ Snow Plow and V-Box Spreader

**3.2.1.10** Bottom rails shall be seamless and sloping (dirt/salt shedding).

**3.2.1.11** Long sills are to be formed trapezoidal ¼" minimum 201 stainless steel.

**3.2.1.12** Rear apron shall be ¼" minimum 8" formed channel.

**3.2.1.13** There shall be no cross members. Floor to be skip welded to formed stainless steel sills.

### **3.2.2 Rear Corner Post, Cab Shield and Sides:**

**3.2.2.1** Shall be 1/4" minimum 201 Stainless Steel.

**3.2.2.2** Top of corner post shall be dirt shedding. A 14-1/2" one-piece 7-gauge minimum stainless steel shall be break formed front to back at 5-1/2" and a downward slope remaining at 9".

**3.2.2.3** The top of post shall house two (2) ½" minimum stainless-steel plate brackets to house the top pivot point.

**3.2.2.4** Tailgate reinforcement plate around the tailgate latch assembly must be ¼" minimum thick.

**3.2.2.5** Reinforcement plate outside must be 16" tall minimum.

**3.2.2.6** Reinforcement plate bottom must be 8-3/4" long minimum.

**3.2.2.7** Reinforcement plate inside bottom height shall be 7-3/8" minimum to the floor.

**3.2.2.8** Reinforcement plate top shall be 4-1/4" minimum from outside to top of floor sheet.

**3.2.2.8.1** All shall be continuously welded.

**3.2.2.9** Three (3) oval factory cut outs for Stop, tail and turn signals, backup, and amber strobe.

**3.2.2.10** No front corner posts. Head sheet to have mirrored image of three (3) weld on full length horizontal side brace each side and shall be continuously welded to side brace, each side.

**3.2.2.11** One (1) Intermediate fully welded horizontal side brace, full-length both sides.



**REQUEST FOR QUOTATION  
CRFQ DOT1900000128**

**(Class 371) 41,000 GVWR Single Axle Dump Truck w/ Snow Plow and V-Box Spreader**

---

**3.2.2.12** 30"x 90" minimum wide cab - shield to have Four (4) oval cut out with grommet mounts: Each side, each front corner.

**3.2.2.13** All Back side of lights must be boxed in with stainless steel.

**3.2.2.14** Stainless steel tubing shall be used to protect electrical wires between lights.

**3.2.2.15** Cabshield must be 201 stainless steel minimum.

**3.2.2.16** There shall be 3" x 6" minimum hard wood sideboards painted black.

**3.2.2.17** The one-piece external side sheet must be break formed and wrap under the body floor no less than 10" extended under the body with a continuous welded seam to floor sheet.

**3.2.3 Tailgate Design:**

**3.2.3.1** Shall be double-acting heavy-duty tailgate.

**3.2.3.2** Bracing shall be full perimeter box type, minimum 6" top and bottom and 4" sides.

**3.2.3.3** There shall be a minimum of two (2) horizontal brace, mid-section.

**3.2.3.4** Top, bottom, and intermediate horizontal braces shall be sloped (dirt/salt shedding).

**3.2.3.5** Top and bottom tailgate pins must be 1 ¼" minimum diameter 303 stainless steel.

**3.2.3.6** Minimum 3/8" stainless steel coil chains shall be long enough to hold tailgate in horizontal position if necessary.

**3.2.3.7** Heavy nylon mesh sleeves shall be installed over tailgate chains to protect body finish.

**3.2.3.8** Lower latch hooks shall be flame cut from 3/4" minimum 201 stainless Steel minimum plate to secure against two (2) 3/8" minimum 201 stainless steel minimum, corner post mounted latch plates, one (1) set each side of the ¾" minimum latch hook per side.

**3.2.3.9** There must be a full width 1" 201 minimum stainless-steel

**REQUEST FOR QUOTATION**  
**CRFQ DOT1900000128**  
**(Class 371) 41,000 GVWR Single Axle Dump Truck w/ Snow Plow and V-Box Spreader**

---

diameter (minimum) tailgate release rod at rear of body.

**3.2.3.10** All tailgate hardware shall be 201 stainless steel minimum.

**3.2.3.11** One (1) Stainless Steel d-ring lift hook mounted on top of tailgate.

**3.2.3.12** Continuous welded body shell (except long sills to floor sheet that are skip welded), cab protector & tailgate.

**3.2.3.13** Stationary 2-1/2" x 20" minimum long grip strut stainless steel steps (two steps) mounted to the front driver's side as far forward as possible on the horizontal side braces.

**3.2.3.13.1** Pull-out stainless-steel ladder shall be mounted below.

**3.2.3.14** Full length 2-1/2" minimum grip strut stainless steel walk rail shall be mounted full length on bottom rub rails, both sides.

**3.2.3.15** Full length 1/4" x 1-1/2" minimum flat stock tarp stock mounted to top horizontal side brace, both sides or equal.

**3.2.3.16** One (1) one-piece stainless steel rod grab handles must be mounted on each side of the 20" step.

**3.2.3.17** Front corner of bottom rub rail must be capped with 7GA minimum stainless steel and be on an approximate 60-degree angle.

**3.2.4 Hoist and Rear Hinge Assembly:**

**3.2.4.1** Heavy duty front telescopic type hoist suitable for use with a Dump body on a road and highway maintenance truck used for snow and ice control, internally mounted in head-sheet.

**3.2.4.2** Hoist shall be NTEA rated Class 50 No exceptions.

**3.2.4.3** Thirty-three thousand-pound (33,000 LB.) capacity minimum at 2000 PSI.

**3.2.4.4** Hoist shall be double-acting (power up and down full length of stroke).

**REQUEST FOR QUOTATION**  
**CRFQ DOT1900000128**  
**(Class 371) 41,000 GVWR Single Axle Dump Truck w/ Snow Plow and V-Box Spreader**

---

**3.2.4.5** Hoist largest diameter stage must be at bottom.

**3.2.4.5.1** Inverted cylinder is not acceptable.

**3.2.4.6** 4.5" inside diameter cylinder base tube (minimum).

**3.2.4.7** 100" stroke (minimum).

**3.2.4.8** All cylinder stages must be nitrated for corrosion resistance and wear resistance.

**3.2.4.9** Internal bore seal design so no packing adjustment or bleeding is required.

**3.2.4.10** Hoist cylinder shall be mounted inside pivoting, trunnion mounted cylinder cover tube.

**3.2.4.11** Shall have standard heavy-duty hoist cradle for trunnion mounted telescopic hoist.

**3.2.4.12** Mounting height shall not exceed 8" from the top of chassis frame to dump body floor.

**3.2.4.13** 6" x 8" x ½" x 38" minimum long formed angle with 2" minimum 303 stainless steel minimum pins with greaseable pins.

**3.2.4.13.1** Each pin is secured by nut/bolt.

**3.2.4.14** Each pin mounts into two (2) 1/2" minimum plates mounted on two sides to the 6" x 8" x ½" minimum formed angle.

**3.2.4.14.1** Outside plate for each set must be 1.125" minimum from end angle with pin centers at 32" minimum.

**3.2.4.15** Each rear hinge block must be a 2-1/2" minimum wide and 3.25" minimum tall plate steel with 5.88" minimum length mounting surface of body to top of block.

**3.2.4.15.1** Each block must accept a 2" minimum dumping stainless steel pivot pin.

**3.2.4.16** Overhang from the center of the rear pivot must be 12" minimum to the end of the floor plate.

**REQUEST FOR QUOTATION**  
**CRFQ DOT1900000128**  
**(Class 371) 41,000 GVWR Single Axle Dump Truck w/ Snow Plow and V-Box Spreader**

---

**3.2.5 The following bed features shall be included:**

**3.2.5.1** Warning light (bed raised) dash or console mounted.

**3.2.5.2** Mud guards, 10 gauge minimum, 201 stainless steel x 24 inches x 30 inches minimum, permanently attached in front of rear wheel and mounted by stainless steel bracket.

**3.2.5.3** Rear mud flaps: Black, 24" x 36" x ½" thick minimum, tire cord reinforced construction with rubber nipples molded into the backside of the guard and mounted by stainless steel brackets with removable connecting rod.

**3.2.5.4** Air operated tailgate shall be "pancake-type" tailgate release valve or equal.

**3.2.5.4.1** The air chamber shall be anchor lock with a spring-over-center latch.

**3.2.5.4.2** Pivot points must include greaseable stainless steel bushings.

**3.2.5.5** OSHA approved corrosion resistant backup alarm, electronic ambient, adjusts to background noise, 112 dba minimum, shock mounted at rear.

**3.2.5.6** Shall have bed body support, both sides.

**3.2.5.7** Dump body shall have a stainless-steel bolt on full width asphalt plate minimum 10" long with stainless hardware.

**3.2.5.8** Shall have one shovel holder installed on bed.

**3.2.5.9** Bed shall have four (4) SS ratchet tie down straps mounted on bed sides.

**3.2.6 Bed Body Lighting:**

**3.2.6.1** All bed body wiring must be uninterrupted and complete with no splices.

**REQUEST FOR QUOTATION**

**CRFQ DOT1900000128**

**(Class 371) 41,000 GVWR Single Axle Dump Truck w/ Snow Plow and V-Box Spreader**

**3.2.6.2** All wire terminal ends (spade, ring, etc.) shall be: crimped soldered to the wires and heat shrink, or weatherproof connectors.

**3.2.6.2.1** Quick fasteners and/or crimp butt connectors will not be acceptable for any connections.

**3.2.6.3** All electrical connections shall be protected with dielectric silicone grease.

**3.2.6.4** All body lights shall be connected to chassis through a waterproof junction box located at rear of truck.

**3.2.6.5** All body lighting – stop, tail, turn, marker lights and reverse lights shall be LED type with sealed weatherproof wiring.

**3.2.6.6** Rear lights shall be shock mounted, recessed oval stop, tail, turn, and recessed oval back up lights shall be mounted in back post.

**3.2.6.7** Shall have three (3) light cluster located in bed body or truck chassis.

**3.2.6.8** Two (2) amber oval LED strobe lights shall be mounted at the front corners of the cab protector and two (2) amber oval LED strobe lights mounted at each outside corner of cab protector.

**3.2.6.8.1** Strobe lights shall be marked and switched in cab.

**3.2.6.8.2** Oval cutouts shall be precut by dump body manufacturer.

**3.2.6.9** Two (2) oval amber LED strobe lights mounted at top of rear corner posts right and left sides and shall be switched in combination with cab protector strobe.

**3.2.6.9.1** Oval cutouts shall be precut by dump body manufacturer.

**3.2.6.10** Shall have LED license plate light.

**3.2.6.11** Bed shall have LED marker lights on front and rear bed corners.

**REQUEST FOR QUOTATION**

**CRFQ DOT1900000128**

**(Class 371) 41,000 GVWR Single Axle Dump Truck w/ Snow Plow and V-Box Spreader**

---

**3.2.7 Under Body Tool Box:**

**3.2.7.1** One (1) stainless steel tool box shall be mounted under body on right side frame rail.

**3.2.7.2** Tool box shall be 18" H x 24" W x 18" D minimum cradled by a structural angle stainless steel frame attached to the truck frame.

**3.2.7.3** Tool box shall have a keyed latch of corrosion resistant hardware, automotive style weather stripping, and a drip rail over the door opening.

**3.2.8 Load Covering System:**

**3.2.8.1** Shall be Aero Brand Model#575 or equal

**3.2.8.2** Shall be electrically controlled.

**3.2.8.3** Electric motor assembly shall include 12 volts sealed direct drive motor with forward and reverse action, cab mounted control switch, with resettable circuit breaker.

**3.2.8.4** Pivot arm assembly shall be constructed in a two (2) piece bent arm configuration of 1 ¼ inch minimum 14-gauge minimum stainless steel or aluminum tubing.

**3.2.8.5** Bent arm extensions shall be constructed of minimum one (1) inch 14gauge, stainless steel or aluminum tubing.

**3.2.8.6** Rear cross shall be constructed of minimum 1 ¼ inch 14-gauge stainless steel or aluminum tubing.

**3.2.8.7** Stainless steel pivot armrests shall be included.

**3.2.8.8** Load covering system shall be provided with minimum of 18 oz. black asphalt rated tarp to fit dump body with brass or stainless-steel eyelets every 2 foot.

**REQUEST FOR QUOTATION**

**CRFQ DOT1900000128**

**(Class 371) 41,000 GVWR Single Axle Dump Truck w/ Snow Plow and V-Box Spreader**

---

**3.3 FRONT SNOW PLOW:**

**3.3.1 Moldboard** - The following are mandatory requirements for the moldboard.

**3.3.1.1 Moldboard Construction** shall be 10-gauge steel and rolled to give the snow a free rolling action. Break formed will not be acceptable.

**3.3.1.2 Overall width** shall be a minimum of 10 foot with 11-foot optional plow will be listed on pricing page.

**3.3.1.3 Overall height** shall be a maximum of 32- inches.

**3.3.1.4 Plow Weight** shall be 1815 pounds minimum.

**3.3.1.5 Moldboard** shall be reinforced at the top and bottom edges.

**3.3.1.5.1 Top of moldboard** shall be reinforced with an integrally structural angle 3-1/2-inch x 2-1/2 x 3/8inch minimum.

**3.3.1.5.2 Bottom angle** shall be minimum of 4-inch x 4-inch x 3/4 inch angle gusseted.

**3.3.1.6 Moldboard** shall have a cutting-edge attack angle with minimum of three (3) different adjustments from 5-degree, 10 degree, and 20-degree vertical measurement from ground using 3/4 inch plus.

**3.3.1.7** Shall have a travel arc of thirty- five degrees (35°) minimum each way; total seventy degrees (70°).

**3.3.1.8** Shall be minimum of eight (8) vertical ribs, 1/2 inch by 3-1/2-inch formed steel.

**3.3.1.9** Shall be continuously welded ribs, moldboard, and angles.

**3.3.1.10** An additional rubber snow shield shall be provided. It shall be minimum 5/16-inch x 12-inch belting and run the entire length of plow.

**3.3.1.10.1** It shall be mounted in a manner as not to add to overall plow height.

## REQUEST FOR QUOTATION

### CRFQ DOT1900000128

#### (Class 371) 41,000 GVWR Single Axle Dump Truck w/ Snow Plow and V-Box Spreader

**3.3.2 Cutting Edges** – The following are mandatory requirements related to the cutting edges.

**3.3.2.1** Cutting edge shall be sectioned, standard AASHTO punched, in three (3) foot and four (4) foot lengths.

**3.3.3 Blade Section:**

**3.3.3.1** Shall be a Kuper Tuca model SX wave or equal.

**3.3.4 Safety Trip Mechanism** – The following are mandatory requirements related to the safety trip mechanism.

**3.3.4.1** Tripping mechanism shall be attached to semi-circle and moldboard ribs and shall use minimum of two (2) compression springs.

**3.3.4.2** The trip mechanism shall hold the plow rigid in the plowing position and trip automatically when cutting edge comes in contact with obstruction then returns to normal plowing position.

**3.3.5 Push Frame** - The following are mandatory requirements related to the push frame.

**3.3.5.1** Push frame shall be of all welded construction designed per manufacturer's heaviest rated specifications.

**3.3.5.1.1** Push frame shall be 120 inches in length for 10-foot plow and 132-inches for 11-foot plow made of 4-inch x 4-inch x 3/8-inch minimum structural tube.

**3.3.5.2** Moldboard to push frame connection shall be by a minimum of seven (7) hinges with each hinge having a fully welded in bushing to house pin.

**3.3.5.2.1** Bushing shall be 1-1/4 inches mounted to two (2) 5/8-inch mounting ears for total bearing surface per bushing of 2 – 1/2 inches.

**3.3.5.3** The A- frame shall be equipped with an oscillating center pin of plow portion hitch of 1.5 inch (minimum) with push



**REQUEST FOR QUOTATION**

**CRFQ DOT1900000128**

**(Class 371) 41,000 GVWR Single Axle Dump Truck w/ Snow Plow and V-Box Spreader**

plate being 1-inch x 33-inch x 5 inches feature to permit the plow to follow uneven road surfaces.

**3.3.5.3.1** Semi-Circle shall be 3-1/2 inches x 3-1/2 inches x 1/2 inch.

**3.3.6 Hydraulic Power Reversing Mechanism:**

**3.3.6.1** Shall be minimum of two (2) double acting 4-inch x 2-inch x 10 inch stroke power reversing nitride hydraulic, cylinders fitted with the fixed base end near the center of the push frame.

**3.3.6.1.1** Cylinders shall be mounted above the semi-circle.

**3.3.6.2** Hydraulic power reverse mechanism shall include a dual cross-over relief cushion valve rated at a minimum of 40 G.P.M.

**3.3.6.3** The "A" frame shall be minimum 4-inch channel with 2.5-inch flanges supporting a 1.5-inch (minimum) center reversing pin mounted in a 3-inch vertical tube with 1/2 inch minimum wall thickness, accommodating the 1.5-inch pin or equivalent.

**3.3.6.3.1** The push ends are welded to a 1 inch x 33 inches x 5-inch base plate having a 1.5-inch pivot hole for the oscillator bar to attach to.

**3.3.7 Plow Storage:**

**3.3.7.1** Plow shall have one adjustable jack stand.

**3.3.8 Snow Plow Cushion Valve:**

**3.3.8.1** A double relief cushion valve must be installed for the plow angle and scraper left/right.

**3.3.8.2** The valve shall be set at 2000 PSI maximum.

**3.3.8.3** The valve shall be constructed of a high-tensile cast iron body with ball and spring style relief that has hardened seat.

**REQUEST FOR QUOTATION  
CRFQ DOT1900000128**

**(Class 371) 41,000 GVWR Single Axle Dump Truck w/ Snow Plow and V-Box Spreader**

---

**3.3.8.3.1** The valve shall be plumbed at the front of the truck for snowplow angle.

**3.3.8.3.2** Shall be plumbed with Parker NPT Stainless steel quick couplers or equal.

**3.3.9 FRONT SNOW PLOW HITCH** – The following are mandatory requirements related to the hitch.

**3.3.9.1** Shall be designed as a universal heaviest rating type unit to carry plows of weight specified.

**3.3.9.2** The hitch shall be a frame type mount adaptable to any conventional truck and shall accommodate the tilt front end on the carrier.

**3.3.9.3** The hitch shall be attached to truck's frame rails behind front bumper.

**3.3.9.4** Hitch shall include a lift system designed at a rated capacity of 8,000 lbs. minimum.

**3.3.9.4.1** Lift cylinder must be same size as plows reversing cylinder for WVDOH's interchangeability.

**3.3.9.5** Truck front plow hitch shall be a WVDOH plow quick hitch Design See attached: **EXHIBIT C**

**3.3.9.6** Hitch frame height shall be approximately 33 inches and hitch width shall be approximately 26 inches.

**3.3.9.6.1** Will be determined at pre-build meeting.

**3.3.9.7** Hitch frame members shall be ½ inches x 4 inches x 4 inches minimum structural angle or tubing.

**3.3.9.7.1** This hitch is low profile for access to the truck's engine compartment.

**3.3.9.8** The lift arm and lift frame shall be designed to accept a 4-inch lift cylinder with nitride cylinder tube.

**3.3.9.8.1** Cylinder pins shall be 1 inch cold rolled steel.

**REQUEST FOR QUOTATION**

**CRFQ DOT1900000128**

**(Class 371) 41,000 GVWR Single Axle Dump Truck w/ Snow Plow and V-Box Spreader**

---

**3.3.9.9** Shall have a self-storing lift arm, accomplished by pulling one (1) 1-inch pin and folding the cylinder up, allows you to re-pin to store.

**3.3.9.10** The telescopic lift arm shall be manufactured of 4-inch x 4-inch x 3/8-inch minimum square outer tubing and 3-inch x 3-inch x 3/8-inch minimum square inner tubing.

**3.3.9.11** The lifting plate shall be 3/8 inch x 4 inch minimum flat material and have two (2) banjo-type chain eyes able to accept 1/2 inch minimum chain as well as the weight of the plow.

**3.3.9.12** Shall also have two (2) stabilizer arms mounted to receiver tube of telescoping arm and outside pivot of hitch.

**3.3.9.13** Shall provide custom 1/2 inch Grade 50 minimum cheek plates which shall be bolted welded or bolted to main hitch and to allow for bolting to truck's frame rail.

**3.3.10 Plow Hydraulic System** – The following are mandatory requirements related to the hydraulic system.

**3.3.10.1** Hydraulic pressure shall be supplied from the truck central hydraulic system through a lift valve and reversing valve (main bank valve) to the plow lift and reversing cylinders.

**3.3.10.2** The vendor shall be required to supply the following hydraulic components:

**A.** One (1) 4-inch lift cylinder with 10-inch stroke double-acting hydraulic lift cylinder (even if we only use one (1) line fitting in upper end with breather), clevis pinned top and bottom.

**B.** Two (2) 4-inch double acting nitride hydraulic reversing cylinders.

**C.** Plow reversing and plow truck portion lift cylinders must be the same size for interchangeability, standardization and one-part number cylinder.

**3.3.11 Paint** – The following are mandatory items related to the paint color.

**REQUEST FOR QUOTATION**  
**CRFQ DOT1900000128**  
**(Class 371) 41,000 GVWR Single Axle Dump Truck w/ Snow Plow and V-Box Spreader**

---

**3.3.11.1** Unit shall be painted with urethane paint black or black powder coating paint code M6388G or equal.

**3.4 V-BOX SPREADER 2-in-1 V-Box, Prewetting/Slurry system:**

**3.4.1 Heavy Duty 201 Stainless Steel V-Box Dual Auger Salt Spreader with Storage Stand.**

**3.4.1.1** Capacity to be 6.0-yard minimum struck capacity.

**3.4.1.2** Inside length to be 9.5 feet maximum and maximum height of 56".

**3.4.1.3** Inside top width to be maximum 83-3/4".

**3.4.1.4** Side slope to be 45-degree minimum.

**3.4.1.5** Front & rear panels slope; minimum rear 9-degree, minimum front 18 degree.

**3.4.1.6** Hopper seams shall continuous welded on inside.

**3.4.1.7** Sides, ends, & side supports to be 10-gauge minimum 201 SS.

**3.4.1.8** Top edge of hopper is formed "J" channel minimum 2" x 7/8".

**3.4.1.9** Dual auger trough is to be 7-gauge minimum 201 SS.

**3.4.1.10** Long sills to be 7-gauge minimum 201 SS continuous welded to side sheet.

**3.4.1.11** Cross sills to be formed 7 gauge minimum 201 SS welded to side supports.

**3.4.1.12** Spreader shall have a 7-gauge minimum 201 SS inverted vee mounted over the dual augers with frame work for stability.

**3.4.1.13** Lift hooks on each corner are 1/4" x 2" minimum formed 201 SS plate.

**REQUEST FOR QUOTATION  
CRFQ DOT1900000128**

**(Class 371) 41,000 GVWR Single Axle Dump Truck w/ Snow Plow and V-Box Spreader**

---

- 3.4.1.14** All hardware shall be 201 SS minimum.
- 3.4.1.15** Hydraulic inter-lock auger shut-off system to shut augers down when cover grates are opened—interlock plumbed at factory.
- 3.4.1.16** 3/8" rod on 3/8" rod Stainless steel top grate screens with anti-freeze hinges are required equipment with auger conveyor v-box units.
- 3.4.1.17** Full width 201SS minimum metal spill shield mounted at front of hopper on top rail with slope facing forward at 45 degree.
  - 3.4.1.17.1** Hopper shall have full spill shield rubber side skirts.
- 3.4.1.18** A full width rear 201 SS minimum light bar shall be mounted with nine (9) LED lights.
  - 3.4.1.18.1** Shall include LED stop, tail, turn, three (3) LED bar light, four (2) amber LED strobes and two (2) LED rear work lights.
  - 3.4.1.18.2** Shall have weatherproof junction box and 7 wire corrosion resistant trailer plug to reach connector of truck.
- 3.4.1.19** One (1) stainless steel ladder mounted at the rear of spreader on right side allowing access from ground to top of spreader with top handrail.
  - 3.4.1.19.1** One (1) grip strut step mounted on top of rear spinner housing frame above rear baffle and full width of spinner housing.
- 3.4.1.20** The V-box spreader shall include a stainless-steel leg stand assembly.
- 3.4.1.21** The stand shall be capable of sliding into an 86" wide dump body with a 5" radius between the sides and floor.
  - 3.4.1.21.1** The base in contact with the dump floor shall not exceed

**REQUEST FOR QUOTATION  
CRFQ DOT1900000128**

**(Class 371) 41,000 GVWR Single Axle Dump Truck w/ Snow Plow and V-Box Spreader**

---

74" width. The spreader stand/leg assembly shall be designed to support an empty spreader hopper.

**3.4.1.22** The spreader frame assembly shall be constructed from 201 grade stainless steel minimum.

**3.4.1.23** The spreader frame shall contain two formed members, full length of the spreader unit on each side.

**3.4.1.24** The two main longitudinal frame members shall be fabricated hat channel design, manufactured from a minimum of 7-gauge 201 grade stainless steel.

**3.4.1.24.1** They shall measure 6" minimum on the inside width and 7.5" minimum in height.

**3.4.1.24.2** The frame shall be open on the bottom side and closed on the top side.

**3.4.1.24.3** The front end of the main longitudinal members shall each include a 6" minimum solid heavy-duty poly nylatron wheel.

**3.4.1.24.4** The nylatron wheel shall be 4,000lb minimum rated without bearings.

**3.4.1.24.5** No steel bushings of bearing are permitted.

**3.4.1.24.6** The rollers will allow the spreader to roll into the dump body of the truck. The through roller shaft hardware shall be stainless steel.

**3.4.1.25** Located between the main longitudinal frame members shall be cross braces manufactured from minimum 7gauge 201 grade stainless steel fabricated channel.

**3.4.1.25.1** These channels shall be 5" minimum wide x 4" minimum deep, open to the bottom as to prevent material hold.

**REQUEST FOR QUOTATION  
CRFQ DOT1900000128**

**(Class 371) 41,000 GVWR Single Axle Dump Truck w/ Snow Plow and V-Box Spreader**

---

**3.4.1.25.2** These supports shall be located on 24" minimum centers.

**3.4.1.25.3** The clearance between the dump body bed and the underside of the cross bracing shall be minimum of 1-1/2".

**3.4.1.26** The rear upper leg frame shall be an offset design located between the main frame rails and the rear lengths.

**3.4.1.26.1** The structure shall be fabricated boxed tube construction, minimum of 7-gauge 201 grade stainless steel.

**3.4.1.26.2** The frame members shall have a sloping angle of 30 degrees minimum down from the frame rail attachment point.

**3.4.1.26.3** The upper leg frame shall have a series of (5) holes to allow for height adjustment of the lower leg.

**3.4.1.27** The rear legs shall be manufactured from fabricated 1/4", minimum 201 grade stainless steel tube.

**3.4.1.27.1** The tubes shall be 5" minimum deep x 2" minimum wide.

**3.4.1.27.2** The legs shall be adjustable within the upper leg frame by means of (5) minimum available height adjustment holes.

**3.4.1.27.3** The rear legs shall be sloped a minimum of 15 degrees from vertical with the lower part of the leg angles away from the spreader body and towards the rear direction.

**3.4.1.27.4** The rear legs shall pin to the upper leg frame with a handle type 1" minimum zinc plated pin.

**3.4.1.27.5** The rear leg shall have a pivoting foot which shall measure a minimum of 10" in length x 2" minimum in width.

**3.4.1.27.6** The foot shall include an integrated handle.

**REQUEST FOR QUOTATION  
CRFQ DOT1900000128**

**(Class 371) 41,000 GVWR Single Axle Dump Truck w/ Snow Plow and V-Box Spreader**

---

- 3.4.1.27.7** The foot shall be fabricated from a minimum of 7gauge 201 grade stainless steel and include a minimum of (5) ¼" x 2" studs on the bottom side to reduce surface slippage.
- 3.4.1.28** The front legs shall be set back from the frames front roller wheels to allow the roller wheels to contact the dump body floor prior to contacting the front legs.
- 3.4.1.28.1** The front legs shall be a tube in tube design, slanted forward at an angle of a minimum of 95 degrees.
- 3.4.1.28.1.1** Also, the legs shall slant to the sides a minimum of 8 degrees.
- 3.4.1.28.2** The upper portion of the front legs shall be constructed from a minimum of 4" x 4" x 7gauge 201 grade stainless steel fabricated square tube.
- 3.4.1.28.3** The upper legs shall have a series of (3) holes to allow for height adjustment.
- 3.4.1.28.4** The lower inner leg shall be fabricated from 3.5" x 3.5" x 3/16" minimum structural stainless-steel tube.
- 3.4.1.28.5** The lower legs shall have a series of 6 holes to allow for height adjustment.
- 3.4.1.28.6** The front leg bottom base shall have a pivoting foot pad, a minimum of 4" wide x 5" deep.
- 3.4.1.28.7** The front legs shall manually actuate into the main frame members when the spreader is installed into a dump body.
- 3.4.1.28.8** When the spreader must be stored, the legs shall be pinned into the locked position with a 1.25" pin minimum.
- 3.4.1.29** The stand assembly shall include trunnion tailgate latches to allow the spreader/stand to be secured into the dump body latch fingers.



**REQUEST FOR QUOTATION  
CRFQ DOT1900000128**

**(Class 371) 41,000 GVWR Single Axle Dump Truck w/ Snow Plow and V-Box Spreader**

---

The trunnion bar assembly shall consist of all stainless-steel components/hardware and tailgate latch pins.

**3.4.1.30** The stand shall include side guide wheels to assist in the loading/unloading of the spreader system. The guide wheels shall be adjustable and designed to ride along the side of the dump body.

**3.4.1.31** The complete assembly shall be high pressure cleaned and SS etched to remove weld slag, splatter, and oils. All stainless steel shall remain in natural stainless-steel finish.

**3.5. Auger**

**3.5.1 Minimum Auger Requirements**

**3.5.1.1** Dual 7" minimum diameter variable pitch auger conveying system. The augers must be counter rotating to help prevent bridging of material. Dual augers extend 2 feet past end of hopper to allow discharge into spinner chute.

**3.5.1.2** Each auger is driven at the rear by a 24.7 CIR hydraulic motor which is directly coupled to a 3.6:1 planetary gear case with 2.5-inch diameter shaft coupled to the end of the auger shaft with a 7/8" cross bolt.

**3.5.1.3** Gear case is directly coupled to end of auger shaft.

**3.5.1.4** Auger shaft connects at front with a 2" 2 bolt flange bearing.

**3.5.1.5** Rear auger drive motors must have motor guards.

**3.5.2 Reservoir Tanks:**

**3.5.2.1(2)** 200-gallon minimum rotation molded medium density .375" polyethylene tank with 5" diameter cap. Includes sump for complete drainage.

**3.5.2.2** Replaceable screen line strainer.

**3.5.2.3** Corrosion resistant shut off valves.

**3.5.2.4** Reservoir tank is angle formed to allow for mounting on the side of a slip-in v-box utilizing 201 stainless steel minimum mounting

**REQUEST FOR QUOTATION**  
**CRFQ DOT1900000128**  
**(Class 371) 41,000 GVWR Single Axle Dump Truck w/ Snow Plow and V-Box Spreader**

---

brackets and hardware.

**3.5.2.5** Supplied with bulk tank fill quick couplings. Internal baffle.

**3.5.2.6** Banjo brand fittings must be provided to allow for filling/unloading.

**3.5.3 Spinner Assembly:**

**3.5.3.1** 10-gauge 201 stainless steel minimum enclosed design.

**3.5.3.2** Spinner assembly shall have a (4) position telescopic adjustment below mounting surface.

**3.5.3.3** Two (2) baffles shall be positioned at the bottom of the spinner chute to direct flow of materials onto spinner disc for directional spread pattern adjustment.

**3.5.3.4** The two (2) spread pattern adjustment baffles shall each have 5 (five) positions of adjustment without the use of tools.

**3.5.3.4.1** The baffle(s) shall utilize a 304SS notched bar that pins into position for a positive lock.

**3.5.3.5** Four (4) bottom spinner deflectors shall be over-lapping to prevent loss of granular material when the deflectors are raised.

**3.5.3.5.1** Front deflector is fixed.

**3.5.3.6** The bottom over-lapping spinner deflectors shall have four (4) positions of rod and pin adjustment without tools.

**3.5.3.6.1** Chain adjustable deflectors are not acceptable.

**3.5.3.7** The bottom over-lapping spinner deflectors shall have the capability to be removed and/or replaced without tools.

**3.5.3.8** Poly 20" diameter spinner disc shall have replaceable machined hub.

**3.5.3.9** Poly spinner disc shall have minimum of six (6) built in spinner vanes.

**REQUEST FOR QUOTATION  
CRFQ DOT1900000128**

**(Class 371) 41,000 GVWR Single Axle Dump Truck w/ Snow Plow and V-Box Spreader**

---

**3.5.3.10** Spinner hydraulic motor shall mount directly on top of spinner disc.

**3.5.3.11** The top mounted spinner motor shall be enclosed in the spinner chute to maximize granular material flow to the spinner disc.

**3.5.3.11.1** For serviceability, the spinner chute shall have open access to the spinner motor.

**3.5.3.12** A spinner bypass chute shall be provided that allows for the stationary unloading of granular material.

**3.5.3.12.1** When in the pivoted “down” position, the chute shall provide complete bypass of the spinner and bottom deflectors.

**3.5.3.12.2** When in the “up” position, the chute shall become part of the enclosed spinner chute providing granular material flow to the spinner.

**3.5.3.12.3** The bypass chute shall have a quick latch system pinning into position without the use of tools.

**3.5.4 Metering Orifice and Slurry Tube:**

**3.5.4.1** Metering Orifice and Slurry Tube shall be bolt-on brackets, with all stainless-steel hardware, and fittings supplied.

**3.5.4.2** Variable displacement orifice provides an extended range of material outputs located in spinner chute.

**3.5.4.3** Variable displacement orifice 22" wide minimum, vented internal at top of spinner chute.

**3.5.4.4** Spreader shall have a stainless-steel liquid injection tube 1" OD which shall be located on the underside of the inverted vee. The injection tube will provide liquid which will be agitated by the spreader augers to create a salt slurry mixture. The liquid for the slurry generation process shall come from the liquid pre-wet system. There shall be a manual ball valve to control flow from the pre-wet to

**REQUEST FOR QUOTATION  
CRFQ DOT1900000128**

**(Class 371) 41,000 GVWR Single Axle Dump Truck w/ Snow Plow and V-Box Spreader**

---

either the slurry injection line or to the spinner pre-wet nozzles  
(variable displacement).

**3.5.5 Hydraulic Pre-Wet System:**

**3.5.5.1** Liquid pumping system shall come complete with all plumbing, pumps with an enclosure, and mounting hardware.

**3.5.5.2** The spray system shall be completely controlled by the ground speed spreader control.

**3.5.5.3** System shall run off a section in valve stack.

**3.5.5.4** Pump housings and gears are made of top-quality bronze and corrosion resistant.

**3.5.5.5** Pump shall be self-priming, pulse free positive displacement design.

**3.5.5.6** Unit shall come with a precision-machined minimum 303 stainless steel shaft.

**3.5.5.7** Bearings are designed of high-performance carbon graphite material selected for wear resistance and long service life, O-ring cover seal for maximum leak protection.

**3.5.5.8** Pump shall come with a built-in relief valve set at 45 PSI maximum to protect against over-pressurization.

**3.5.5.9** Pump shall have a continuous duty rating of 125 PSI maximum.

**3.5.5.10** Pump shall be plumbed through a minimum 0-15 maximum GPM flow meter, made of a non- corrosive material.

**3.5.5.11** Pump shall be capable of 8 GPM minimum at 40 PSI maximum.

**3.5.5.12** Hydraulic motor must be a 12.5cc minimum and mount directly to the pump and have a machined aluminum mounting bracket.

**3.5.5.13** Hydraulic connections shall be bulkhead style mounted in bottom of enclosure.

**REQUEST FOR QUOTATION  
CRFQ DOT1900000128**

**(Class 371) 41,000 GVWR Single Axle Dump Truck w/ Snow Plow and V-Box Spreader**

---

**3.5.5.14** All hydraulics inside enclosure shall be hard plumbed.

**3.5.5.15** Pumps shall be mounted in a Nema 4x style weather tight enclosure.

**3.5.5.16** All plumbing shall be included for a 4-nozzle system with check valves.

**3.5.5.17** There shall be a ¾" strainer with stainless steel maximum 20 mesh screen, and a poly 3-way ball valve for flushing pump. shall be mounted on Vee-Box Spreader on passenger side rear.

**3.6 CENTRAL HYDRAULIC SYSTEM-** The Central Hydraulic System shall be completely adjusted to proper pressures. Spreader controls shall be calibrated and ready for use when delivered. Plow Balance system shall be adjusted and ready for use.

**3.6.1 Power Take Off:**

**3.6.1.1** Power take off shall be made of cast iron.

**3.6.1.2** Unit shall be capable of mounting to fully automatic style transmission.

**3.6.1.3** PTO shall be of the Hot Shift design and have a rotatable direct mount cast iron flange for the hydraulic pump to mate to. Shall be of the Wet Spline design, PTO/pump shafts are bathed in oil.

**3.6.1.4** PTO to engine speed shall be in the maximum range of 116% to 120%.

**3.6.1.5** Unit shall have in internal solenoid shifting coil no external shifting is acceptable.

**3.6.1.6** PTO must have automatic shutdown with override switch for low oil and hot oil conditions.

**3.6.1.7** PTO must have continuous torque rating of 390lb. ft. maximum.

**3.6.2 Hydraulic Pump:**

**3.6.2.1** The hydraulic pump shall have a minimum displacement of 75cc.

**3.6.2.2** The hydraulic pump shall be direct flange mount to PTO.

**REQUEST FOR QUOTATION  
CRFQ DOT1900000128**

**(Class 371) 41,000 GVWR Single Axle Dump Truck w/ Snow Plow and V-Box Spreader**

---

**3.6.2.3** The piston pump (load sensing type) must be capable of 48 GPM minimum and a minimum of 3000 PSI at 2500 RPM.

**3.6.2.4** Pump must have rear ports to avoid multiple 90-degree bends in suction line.

**3.6.2.5** The case drain must be positioned as high as possible and directed back to the reservoir without passing through the return line filter.

**3.6.2.6** Pump must have #24 minimum size O-ring port with 2" minimum barb fitting, for suction port and 1" minimum O-ring pressure port.

**3.6.2.7** Pump must be all cast iron design.

**3.6.2.8** The pump must have internal bleed down compensator option.

**3.6.2.9** Compensator shall have 2 ports to choose from for the load sense line for ease of installation.

**3.6.3 Hydraulic Stack Valve:**

**3.6.3.1** The valve shall be of a mobile stackable design load sensing type.

**3.6.3.2** The valve shall be all cast iron design and all sections must be of the same valve series.

**3.6.3.3** The valve shall be capable of a nominal 35 GPM minimum with published flow curves to 40 GPM maximum.

**3.6.3.4** The valve must be pressure and flow compensated.

**3.6.3.5** Inlet and outlet ports shall be 1" O-ring, all working ports shall be 5/8" O-ring minimum.

**3.6.3.6** Valve shall be arranged as follows:

**A.** Inlet cap with top ported pressure and tank, load sense and drain ports, must also have pressure core blocking to help coupler disconnect.

**B.** Double acting cylinder spool for hoist 0 minimum-32 maximum GPM, proportional 12VDC operated, with spring return to

**REQUEST FOR QUOTATION  
CRFQ DOT1900000128**

**(Class 371) 41,000 GVWR Single Axle Dump Truck w/ Snow Plow and V-Box Spreader**

---

neutral. Section shall have manual handle overrides with stroke limiters and 500 PSI minimum down side load sense relief.

C. Double acting cylinder spool for plow lift, proportional 12VDC operated with spring return to neutral. Pressure compensated 0 minimum-10 maximum GPM main spool. Section shall have manual handle overrides and stroke limiters.

D. Double acting cylinder spool for plow angle, proportional 12VDC operated with spring return to neutral. Pressure compensated 0 minimum – 15 maximum GPM main spool. Section shall have manual handle overrides and stroke limiters.

E. Single acting 0 minimum – 15 maximum GPM spool for feeder, proportional 12VDC spring to center with manual override.

F. Single acting 0 minimum -7 maximum GPM spool for spinner, proportional 12VDC spring to center with manual override.

G. Single acting 0 minimum -7 maximum GPM spool for pre-wet, proportional 12VDC spring to center with manual override.

H. Single acting 0 minimum – 15 maximum GPM spool for Anti-Ice, proportional 12VDC spring to center with manual override.

**3.6.3.7** Spreader and pre-wet sections shall be part of a manifold assembly that has a bleed orifice and bolts to the valve sections.

**3.6.3.7.1** Aluminum single block manifold valves and sub-plate mounted valves will not be accepted.

**3.6.4 CONTROLS FOR DUMP BODY HOIST and SNOW PLOW and SPREADER:**

**3.6.4.1** Shall be a one-piece modular control arm design for a variety of joystick controls, control and switch configurations.

**3.6.4.2** Unit shall come with 2 fully proportional joysticks for hoist and plow.

**3.6.4.3** Shall have a single axis control with dead man switch for hoist.

**3.6.4.4** Shall have a dual axis “+” design for snowplow and wing up/down and left/right control.

## REQUEST FOR QUOTATION

CRFQ DOT1900000128

(Class 371) 41,000 GVWR Single Axle Dump Truck w/ Snow Plow and V-Box Spreader

**3.6.4.5** CAN based wiring for ease of installation.

**3.6.4.6** Joysticks can be trimmed for minimum and maximum speed on screen.

**3.6.4.7** Armrest style console shall be fully adjustable to accommodate automatic transmissions, and mount close to drivers seat right hand side.

**3.6.4.8** Control unit shall be fully adjustable, and swivel left to right.

**3.6.4.9** Display messages for: Low Oil, Body Up, Change Filter, Plow Float and lane selection.

**3.6.4.10** All messages shall be displayed on the display and show the actual name of the message.

**3.6.4.11** Console shall have 3 on/off rocker switches in the arm for left, center, and right lane for anti-icing.

**3.6.4.12** Console shall have a PTO switch for on/off, Plow balance switch for on/off and a momentary position for low oil override.

**3.6.4.13** Shall be full closed loop operation for auger, pre-wet and anti-ice functions.

**3.6.4.14** Closed loop on the auger shall be with the sensor built into the motor and shall be a M12 connection.

**3.6.4.15** Unit shall have a surface patrol air/temp sensor and must be on display.

**3.6.4.16** Unit shall come with full schematic documentation.

**3.7 SPREADER CONTROLLER-** The intent of this specification is to describe a complete control system that operates on a CAN-Bus. The system communicates over a CANOpen bus system using CANOpen protocol.

### **3.7.1 The System:**

**3.7.1.1** The system shall consist of four primary modules that reside on the CAN bus and allow flexibility in mounting configurations. The system is completely expandable and allows for additional modules to be added to the CAN bus. All four primary components of the system are software upgradeable. The configuration file of a calibrated



**REQUEST FOR QUOTATION  
CRFQ DOT1900000128**

**(Class 371) 41,000 GVWR Single Axle Dump Truck w/ Snow Plow and V-Box Spreader**

---

system can be saved for transfer to other systems or as a backup providing the ability to use a specific configuration for varying vehicle use or operator skill level.

**3.7.1.1.1** The configuration file will be accessible by a USB port located in the display.

**3.7.1.1.2** The original configuration is maintained at the factory as a secondary backup and is traceable by part number.

**3.7.1.2** The in-cab axis controls must be placed on the CAN Open bus by utilizing an encoder module which has (5) 0-5v analog inputs and (14) PnP Digital Inputs.

**3.7.1.2.1** The Encoder module will use a circuit board that has been conformal coated to provide moisture and shock resistance.

**3.7.1.2.2** The system will support up to (2) Joystick encoder modules and be able to support 10 physical joystick axes maximum and 10 virtual axes maximum.

**3.7.1.3** The display can be attached to the system panel or remote mounted. Joystick function will be clearly labeled on a graphic overlay providing basic operator instruction.

**3.7.1.3.1** The system panel can be positioned over a 360-degree rotation and 4 inches minimum of vertical travel on its mounting tube.

**3.7.1.3.2** The optional Touch-guard panel can be remote mounted, mounted in the system panel, or armrest.

**3.7.1.3.3** Up to (4) Touch-guard systems can be associated on the same CAN bus.

**3.7.1.4** The system must boot in 35 seconds or less and must not consume power when the ignition key is turned off.

**3.7.1.4.1** Systems that draw power in the "off mode" to manage system boot time between ignition cycles are not acceptable.

**REQUEST FOR QUOTATION  
CRFQ DOT1900000128**

**(Class 371) 41,000 GVWR Single Axle Dump Truck w/ Snow Plow and V-Box Spreader**

---

**3.7.2 The Display:**

**3.7.2.1** The Display must include a 7 inch minimum, color touchscreen enclosed within aluminum housing. (1) USB port and (4) Digital outputs capable to 400 mA minimum.

**3.7.2.2** The display will include a well-designed User Interface (UI) that allows the user to navigate within the system software. The UI will include a self-guided tutorial for setup and calibration. Context appropriate help menus will also be available within individual setup screens.

**3.7.2.2.1** The display must use a panel layout design which can be customized by the end user by changing the location, size, and color of the panels.

**3.7.2.2.2** Display shall have a USB drive for firmware updates, configurations, and calibrations saving and uploading.

**3.7.2.2.3** The complete configuration and calibration values shall also be in a spread sheet format when downloaded.

**3.7.2.2.4** The operator shall be able to make changes to the rate, lane, pre-wet, and anti-ice functions using the operator panel or the touchscreen.

**3.7.2.3** The screen layout will be user defined to optimize functions as well as to view and interact with the system within a 4x5 inch minimum grid layout.

**3.7.2.3.1** Users may combine or separate grid location boxes in order to view system information in the combination and shape of their choosing.

**3.7.2.3.2** Users will be able to reconfigure the system for rapid transition between winter and summer operations with unique layouts and system configurations.

**3.7.2.4** System information on the screen may include, but is not limited to:

**3.7.2.4.1** granular rates, pre-wet and anti-ice rates, lane indication, road/air temperature, hydraulic pressure, system status, error messages, plow float indication, auto/manual mode indication and material currently being used.

## **REQUEST FOR QUOTATION**

### **CRFQ DOT1900000128**

#### **(Class 371) 41,000 GVWR Single Axle Dump Truck w/ Snow Plow and V-Box Spreader**

---

**3.7.2.4.2** Active functions that are not in use shall show “off” and the graphic be “grayed out” for ease of operator interpretation.

**3.7.2.4.3** Tile color assignments may be customized by the user.

**3.7.2.5** The display will provide a built-in diagnostic feature allowing technicians to view all input signals in real time.

**3.7.2.5.1** The display will also provide error logging and system status change logging for reviewing operator inputs.

#### **3.7.3 The Software:**

**3.7.3.1** The system shall incorporate three levels of security and access that is password protected and defined by the user.

**3.7.3.1.1** The three levels of access called “user”, “technician” and “admin” shall give the user varying levels of access to the system setup, data, configuration fields and parameters based upon access given.

**3.7.3.1.2** The “administrator” shall have full access to all menus in the system and have the ability to make system configuration changes as well as system parameter changes.

**3.7.3.2** Spreader and liquid functions must have the ability to be controlled utilizing closed loop feedback.

**3.7.3.2.1** The system will automatically default to open loop operation in the event of a sensor failure or loss of input

**3.7.3.2.2** The system will alert the operator and log the error.

**3.7.3.2.3** The system shall have “over speed” protection for the liquid functions that will alert the operator and shut down the liquid function when the driver has exceeded a user defined speed.

**3.7.3.3** Non-critical alerts such as sensor faults must not create alarms that distract the driver by requiring action to clear or stop the audible alarm.

**3.7.3.3.1** When a sensor fault is detected, materiel application will continue in open loop mode.

## REQUEST FOR QUOTATION

CRFQ DOT1900000128

(Class 371) 41,000 GVWR Single Axle Dump Truck w/ Snow Plow and V-Box Spreader

**3.7.3.4** The software shall include as a baked in safety feature the ability to configure a “Panic mode” where momentary operation of a switch in the console starts a timed cycle which automatically retracts user specified functions at a predetermined trim value.

**3.7.3.4.1** After the cycle times out the system shall return to normal operation.

**3.7.3.5** The software shall incorporate a “test speed” mode for use in testing the system safely without requiring the truck to be moving or the drive axles engaged.

**3.7.3.6** The system must be able to independently operate a second spreader (such as a tow plow) that includes liquid or granular application without the installation of multiple control systems.

**3.7.3.6.1** Rate information must be able to be displayed on a single display screen for both the main unit and the towed equipment.

**3.7.3.6.2** Both must be controlled from one operator panel.

**3.7.3.6.3** Application rates may run independently or be slaved to the main unit.

**3.7.3.6.4** The system will also be capable of dynamic variable gate control and cross conveyor support.

### **3.7.4 The Valve driver module:**

**3.7.4.1** IP68 compliant (dust, submersible and water type) sealed assembly shall be mounted to the valve enclosure providing both interior and exterior electrical connections.

**3.7.4.1.1** The valve driver module drives maximum of (14) 6-amp PWM channels, accepts 4 – 20mA input, 4 closed loop feedback signals, and multiple digital inputs.

**3.7.4.1.1.1** All PWM outputs are software configurable and can be controlled by closed loop operation, proportional input devices, or digital input devices.

**3.7.4.1.2** The module includes: over temperature shutdown, over current shutdown, and low voltage shutdown.

## **REQUEST FOR QUOTATION**

**CRFQ DOT1900000128**

**(Class 371) 41,000 GVWR Single Axle Dump Truck w/ Snow Plow and V-Box Spreader**

---

**3.7.4.1.3** All electrical connections are IP68 sealed when mated, utilizing threaded connections for positive retention.

### **3.7.5 The Operator panel:**

**3.7.5.1** The operator panel shall be enclosed in an aluminum housing which includes crash bars to protect the buttons and rotary encoders.

**3.7.5.1.1** It will include a silicone keypad with conductive carbon contacts and (3) rotary encoders that are individually repairable.

**3.7.5.1.1.1** These encoders will have detent positions that will be user programmable as to the value of each increment in the setup menu.

**3.7.5.2** The operator panel provides input capabilities to support RS232, RS422, truck speed input, and multiple digital input/output.

**3.7.5.3** The panel shall have surface patrol air temperature sending unit.

**3.7.5.4** The panel has built in LED backlighting that dims with the display for night viewing.

**3.7.5.5** The panel shall incorporate button labeled: Blast, Pause, Liquid, Spreader, Mode, Product, and Select.

### **3.7.6 "TPE" Thermoplastic Elastomer Wiring Specification:**

**3.7.6.1** The system must make heavy use of electrical connections and cables that resist corrosion and contaminant ingress in all areas exposed to the elements.

**3.7.6.2** Wiring and harness system shall meet ISO rating IP68 and NEMA 6.

**3.7.6.3** The connectors shall be stainless steel or nickel-plated brass.

**3.7.6.3.1** Each shall have three sealing points: the lock ring itself, a raised portion of the molded plastic around each pin, and a Viton O-ring that seals the entire connector.

**3.7.6.4** The cable jacket shall be TPE- thermoplastic elastomer and molded to the connectors.

## REQUEST FOR QUOTATION

CRFQ DOT1900000128

(Class 371) 41,000 GVWR Single Axle Dump Truck w/ Snow Plow and V-Box Spreader

**3.7.6.5** Connectors and harness shall be rated and tested for a temperature range from – 30C to + 70C.

**3.7.6.6** Cabling shall be rated excellent in low temperature flexibility and in its resistance to oxidation, heat, oil, weather, sun, ozone, abrasion, electrical priorities, flame, water, acid, alkali, gasoline, benzol, toluol, degreaser solvents, alcohol, and weld slag.

### **3.7.7 Reservoir/Valve Compartment:**

**3.7.7.1** Shall have one (1) 30 gallon all-welded 7 gauge minimum 201 stainless steel hydraulic oil reservoir/valve compartment frame mounted.

**3.7.7.1.1** Shall be mounted in a manner not to transmit any truck torsional loads thru the tank.

**3.7.7.1.2** Valve component shall be accessible with bed body down.

**3.7.7.2** Hydraulic Tank shall be internally baffled and must have oil level site glass with thermometer.

**3.7.7.3** Valve enclosure shall be protected from both road and pressure washer spray and shall accommodate valve stack and plow balance valve.

**3.7.7.4** A 2-inch full flow brass ball valve shall be plumbed at the suction port of the tank.

**3.7.7.5** Hydraulic oil filter shall be mounted in the reservoir.

**3.7.7.5.1** Hydraulic filter shall be a 10-micron minimum with a bypass and replaceable cartridge.

**3.7.7.5.2** Filter shall be capable of 80 GPM minimum flow capacity.

**3.7.7.6** Tank shall be equipped with a 10-micron minimum filler/breather cap with removable 500-micron minimum stainless-steel strainer.

**3.7.7.7** Tank shall include low oil, filter and temperature sensors.

**REQUEST FOR QUOTATION**

**CRFQ DOT1900000128**

**(Class 371) 41,000 GVWR Single Axle Dump Truck w/ Snow Plow and V-Box Spreader**

---

**3.7.8 Hydraulic Lines and Fittings:**

**3.7.8.1 Stainless steel tubing to be used under body and cab in lieu of hosing.**

**3.7.8.1.1 Only hosing to be used is at the ends of the stainless-steel tubing to each function's quick couplers or connection.**

**3.7.8.1.2 Tubing shall be seamless #201 minimum stainless-steel construction with a minimum wall thickness of 0.065".**

**3.7.8.1.2.1 The ends must be flared to accommodate a 37-degree JIC fitting.**

**3.7.8.1.2.2 The use of compression fittings is not acceptable.**

**3.7.8.1.2.3 Spacing of ½ inch minimum of each tube to allow for material to fall between each tube.**

**3.7.8.2 All stainless tubing must be mounted in polyurethane poly green tube clamps.**

**3.7.8.3 All hoses shall be wire braid reinforced with swaged on high pressure JIC 37-degree tapered seat end fittings.**

**3.7.8.4 All fittings & adapters shall be forged steel (No tapered pipe fittings except on suction hose).**

**3.7.8.5 Spreader stainless steel hose couplers parker NPT or equal shall be mounted on right rear bed side.**

**3.7.8.6 Shall have polymer dust plugs or caps on all couplers with retainer straps.**

**3.7.8.7 All hoses shall be routed away from chassis exhaust whenever possible to protect against heat deterioration.**

**3.7.8.8 All hoses shall be properly rated for pressure of hydraulic system.**

**3.7.8.9 All hose ends connecting to valve assembly shall be 90-degree female JIC swivel.**

**REQUEST FOR QUOTATION**

**CRFQ DOT1900000128**

**(Class 371) 41,000 GVWR Single Axle Dump Truck w/ Snow Plow and V-Box Spreader**

---

**3.7.8.10** Suction Hose shall be 2" ID SAE 100R4 style or equal, connecting the pump and reservoir with king nipples, with both ends being double clamped with T-bolt style stainless steel super clamps.

**3.7.8.11** Pressure hose shall be 1" ID minimum 2000 PSI rated with female JIC swivels at both ends.

**3.7.8.12** Return line shall be 1 ¼" ID SAE 100R4 style or equal with female JIC swivels at both ends.

**3.7.8.13** Hoist raise line shall be ¾" ID, lower line ½", minimum 2250 PSI rated with female JIC swivels at both ends.

**3.7.8.14** Plow and wing lines shall be ½" ID minimum 2250 PSI rated, ran to front of truck with female JIC swivels at both ends.

**3.7.8.15** Auger and anti-ice line shall be ¾" ID minimum 2250 PSI rated and have female JIC swivels at both ends.

**3.7.8.16** Spinner line shall be ½" ID minimum 2250 PSI rated and have female JIC swivels at both ends.

**3.7.8.17** Spreader return line shall be 1" ID SAE 100R4 style or equal with female JIC swivels at both ends.

**3.7.8.18** Pump case drain shall be ¾" ID minimum 2250 PSI rated and have female JIC swivels at both ends.

**3.7.8.19** Load sense line shall be 3/8" ID 2250 PSI minimum rated and have female JIC swivels at both ends.

**3.7.9 PLOW BALANCE VALVE**

**3.7.9.1** System to be supplied with a plow balance valve.

**3.7.9.1.1** Valve to be designed to offset a specific (adjustable) plow weight when activated.

**3.7.9.1.2** Valve to be of cartridge and manifold design, and electrically activated.



## **REQUEST FOR QUOTATION**

**CRFQ DOT1900000128**

**(Class 371) 41,000 GVWR Single Axle Dump Truck w/ Snow Plow and V-Box Spreader**

---

- 3.7.9.1.3** In the case of a load sense hydraulic system, the valve shall be activated by a single solenoid.
- 3.7.9.1.4** In the case of an open center system, the valve is to be activated by two solenoids- one for the plow offset and one for an integral unloader.
- 3.7.9.2** The plow balance system must not alter the operation of any other hydraulic function on the vehicle or effect the performance of other hydraulically operated equipment including wing plow, body hoist, and plow hoist or angle, or spreader functions.
  - 3.7.9.2.1** Operation of any electrical switches beyond the normal up/down command to raise or lower the plow is not acceptable.
- 3.7.9.3** The plow balance system will remain electrically activated when lifting the plow from the road surface.
  - 3.7.9.3.1** Plow lift must be immediate.
    - 3.7.9.3.1.1** It is not necessary to turn off the system for plow lift.
    - 3.7.9.3.2** Plow lowering and return to balance mode must be done by activating the plow lever or switch to the lower mode.
- 3.7.9.4** The plow balance system must be able to hold the plow in the up position indefinitely.
- 3.7.9.5** The plow balance manifold shall be of cartridge style valve utilizing "floating" style cartridge valves.
- 3.7.9.6** The valve body must be constructed of aluminum and have minimum construction whole plugs.
- 3.7.9.7** All solenoid valve coils shall have manual override capabilities.
- 3.7.9.8** Manifold must include a pressure test point for use when checking balance pressures.
  - 3.7.9.8.1** The pressure test point must be capable of taping into the system at pressures of up to 5000 PSI.

## REQUEST FOR QUOTATION

CRFQ DOT1900000128

**(Class 371) 41,000 GVWR Single Axle Dump Truck w/ Snow Plow and V-Box Spreader**

---

**3.7.9.9** The plow balance valve must be installed in the valve/tank combination.

### **3.7.10 Hydraulic Test and Inspection:**

**3.7.10.1** Any items not specifically stated herein, but necessary for proper system operation, shall comply with recommended hydraulic industry standards.

**3.7.10.2** The vendor shall be responsible for pre-testing of hydraulic system which shall include the following:

**3.7.10.2.1** A startup and initial high pressure run of all hydraulic system components shall be done to check for leaks, heat buildup, system efficiency, pressure settings, etc.

**3.7.10.3** Vendor will be responsible for initial test of spreader and all plow circuits including wing plow and wet tank if equipped.

**3.7.10.4** After complete testing of hydraulic system, hydraulic filter must be changed.

### **3.7.11 Miscellaneous Information:**

**3.7.11.1** The vendor is responsible to furnish a truck that is properly engineered and that conforms to all and any laws governing such equipment.

**3.7.11.2** All sheared square and rounded edges of truck ,spreader and plow shall not be sharp.

### **3.7.12 Unspecified Accessories & Features:**

**3.7.12.1** All parts, equipment, accessories, materials, design and performance characteristics not specified herein, but which are necessary to provide a complete unit, must be furnished with each unit and required to conform to strength, quality of material, and quality of workmanship to those which are advertised and provided to the market in general by the unit Industry.

**3.7.12.2** All parts and accessories advertised and regularly supplied as standard shall be included, except those which would represent

## REQUEST FOR QUOTATION

CRFQ DOT1900000128

**(Class 371) 41,000 GVWR Single Axle Dump Truck w/ Snow Plow and V-Box Spreader**

---

duplication of these specified and except those which, by specification, are not to be furnished.

**3.7.12.3** All standard safety features, required by Federal and State Law, shall be included.

**3.7.12.4** Inspection: WVDOH requires unit shall have a West Virginia State inspection sticker upon delivery.

**3.7.12.5** Unit shall be delivered: to WVDOH with all manufacturers recommended safety related decals and safety features intact.

### **3.7.13 Pre Build Meeting:**

**3.7.13.1** After award of contract there will be a mandatory pre-build meeting with successful vendor, manufacturers and up fitters at address below or successful vendor's location  
The WVDOT/Equipment Division,  
83 Brushy Fork Rd. Crossing,  
Buckhannon WV.

### **3.7.14 Warranty:**

**3.7.14.1 Bumper to Bumper:** 1-year Factory Standard Warranty shall start on the final date of acceptance for the entire order.

**3.7.14.2 Engine Warranty:** 100% Parts and Labor for 60 months 150,000 Mile Engine Warranty, 5500 hours. Engine block shall be warranted against external perforation from corrosion for 60 months 100% parts and labor.

**3.7.14.3 Emissions Warranty:** 100% Parts and Labor for all emission related components to include the DPF for 60 Months 150,000 miles or 5500 engine hours. Shall be warranted against corrosion, rust, rust thru etc. regardless of atmospheric conditions.

**3.7.14.4 Transmission Warranty:** 100% Parts and Labor for 2 years unlimited mileage and hours. The transmission shall include all internal and external components related to the automatic transmission. This warranty shall also include, but not limited to, the transmission cooler, cooler hoses or lines, and all electrical

## REQUEST FOR QUOTATION

CRFQ DOT1900000128

**(Class 371) 41,000 GVWR Single Axle Dump Truck w/ Snow Plow and V-Box Spreader**

---

transmission controls, harnesses, connections and modules regardless of atmospheric conditions.

**3.7.14.5 Radiator Warranty:** 100% for parts and labor for 2 years, regardless of atmospheric conditions.

**3.7.14.6 Differential/Axle Warranty:** Shall be 36 months/350,000 miles, Parts and Labor

**3.7.14.7 Dump Body Warranty:** Constructability and durability shall be guaranteed for 5 years parts and labor. Body hoist assembly 3 years parts and labor. Air Tailgate latch system, 3 years parts and labor. All body wiring and lighting shall be warranted for 5 years parts and labor.

**3.7.14.8 Central Hydraulic System Warranty:** Complete Central Hydraulic System and components shall be warranted for 2 years 100% parts and labor. All wiring on system shall be warranted for 5 years 100% parts and labor. Hydraulic pump shall be 3 years 100% parts and labor.

**3.7.14.9 Front Plow:** Complete Plow warranty shall be 2 years 100% parts and labor.

**3.7.14.10 V-Box Spreader and Wet Tank Warranty:** 2 years, 100 % parts and labor.

**3.7.14.11 Cab, Cab Structure, Frame Rails and Crossmembers Warranty:** Cab, Cab Structure, Frame Rails and Crossmembers shall be warranty for corrosion for 5 years unlimited mileage 100% parts and labor.

### **3.7.15 Representative Unit for Test:**

**3.7.15.1** The successful vendor must (if specified) provide the DOH one (1) completed represented unit to be observed and evaluated on each order to insure compliance with specification. If requested, the time period for testing and evaluation shall be seven (7) working days following receipt of the unit. DOH will incur no obligation for deterioration of surfaces, finishes, seals, and mechanical or electrical parts on the unit resulting from operation and testing within the limits of these specifications; nor will DOH incur obligation for damage to the unit resulting from failure to meet specifications when

**REQUEST FOR QUOTATION  
CRFQ DOT1900000128**

**(Class 371) 41,000 GVWR Single Axle Dump Truck w/ Snow Plow and V-Box Spreader**

---

due care and attention is given by DOH and testing is done within the limits of these specifications. Failure of the pilot unit to satisfactorily meet specifications as bid may be cause for cancellation of the purchase order and return of the delivered unit along with all associated equipment to the vendor at the vendor's expense.

**3.7.16 Operating and Service Manuals and Parts Lists:**

**3.7.16.1** An operator's manual must be included with each unit upon delivery. A "line sheet" (if applicable) and the "Equipment Preventative Maintenance Questionnaire", (Exhibit "B") must be with pilot unit upon delivery. Attn: Marcia Lee. There must be 12 service/shop/maintenance manuals and 14 parts manuals; USB storage drive is preferred in lieu of parts manuals. Manuals and USB storage drive shall be delivered upon completion of delivery of total units. Failure to do so will delay payment.

**3.7.17 Training:**

**3.7.17.1** Manufacturers and/or dealers will be required to stage a thorough seminar on the subjects of Preventative Maintenance, Operator, and Mechanic Training. In order to keep operators and mechanics updated, the successful vendor shall conduct training sessions covering the operation, maintenance, trouble- shooting with each purchase order against this open end contract.

Manufacturers and/or dealers shall be required to furnish the Training Academy with one (1) Operator's Manual to be shipped direct to

**WVDOH**  
Training Academy  
P.O. Box 610  
Buckhannon, West Virginia 26201

Prior to delivery of the pilot unit. Training seminar to be held at the WVDOH, Equipment Division, Buckhannon, WV.

**3.7.18 Preventative Maintenance & Operator Procedures:**

**3.7.18.1** Manufacturers and/or dealers will be required to submit to the Equipment Division, in addition to the operating and service manuals, booklets and pamphlets explaining the Preventative Maintenance and Operator Procedures to be used by the operators of this equipment, and must include such things as daily prestart inspection procedure, service schedule, and routine maintenance required, safety precautions, etc. The successful vendor shall

**REQUEST FOR QUOTATION  
CRFQ DOT1900000128**

**(Class 371) 41,000 GVWR Single Axle Dump Truck w/ Snow Plow and V-Box Spreader**

---

furnish all training aids; i.e. videos, projectors as required in conducting the training.

**4. CONTRACT AWARD:**

- 4.1 Contract Award:** The Contract is intended to provide Agencies with a purchase price on all Contract Items. The Contract shall be awarded to the Vendor that provides all the Contract Items meeting the required specifications for the lowest overall total cost as shown on the Pricing Pages.
- 4.2 Pricing Pages:** Vendor must complete and submit the Pricing Pages (**Exhibit A**) by completing the Year, Make, Model and inserting quoted Unit Price. Vendor shall take estimated Quantity and multiply by unit price to get grand total. Vendor should complete the **Exhibit A** Pricing Pages in their entirety as failure to do so may result in Vendor's bids being disqualified.

The Pricing Pages contain a list of the Contract Items and estimated purchase volume. The estimated purchase volume for each item represents the approximate volume of anticipated purchases only. No future use of the Contract or any individual item is guaranteed or implied.

Vendor should electronically enter the information into the Pricing Pages through wvOASIS, if available, or as an electronic document. In most cases, the Vendor can request an electronic copy of the Pricing Pages for bid purposes by sending an email request to the following address:  
crystal.g.hustead@wv.gov

**5. ORDERING AND PAYMENT:**

- 5.1 Ordering:** Vendor shall accept orders through wvOASIS, regular mail, facsimile, e-mail, or any other written form of communication. Vendor may, but is not required to, accept on-line orders through a secure internet ordering portal/website. If Vendor has the ability to accept on-line orders, it should include in its response a brief description of how Agencies may utilize the on-line ordering system. Vendor shall ensure that its on-line ordering system is properly secured prior to processing Agency orders on-line.
- 5.2 Payment:** Vendor shall accept payment in accordance with the payment procedures of the State of West Virginia.

**REQUEST FOR QUOTATION  
CRFQ DOT190000128**

**(Class 371) 41,000 GVWR Single Axle Dump Truck w/ Snow Plow and V-Box Spreader**

---

**6. DELIVERY AND RETURN:**

**6.1 Delivery Time:** A completed pilot model for inspection must be provided within 120 working day(s) after receipt of the pilot model order, by the successful vendor. Vendor shall deliver standard orders within 180 working days after orders are received. Working day is defined as any week day, Monday thru Friday, excluding Federal and State Holidays. Vendor shall ship all orders until a minimum delivery quantity is met.

**6.2 Late Delivery:** The Agency placing the order under this Contract must be notified in writing if orders will be delayed for any reason. Any delay in delivery that could cause harm to an Agency will be grounds for cancellation of the delayed order, and/or obtaining the items ordered from a third party.

Any Agency seeking to obtain items from a third party under this provision must first obtain approval of the Purchasing Division.

**6.3 Delivery Payment/Risk of Loss:** Standard order delivery shall be F.O.B. destination to the Agency's location. Vendor shall include the cost of standard order delivery charges in its bid pricing/discount and is not permitted to charge the Agency separately for such delivery.

**6.4 Condition of Unit(s) Upon Delivery:** All units must arrive at the prescribed delivery point having been completely pre-serviced with oil, lubricants, and coolant. All prescribed precautions pertaining to first operations and break-in of the unit are to be posted conspicuously on the unit for ready observance by the operator.

**6.5 Delivery Point:** Delivery point of the completed representative unit will be the WVDOH, Equipment Division, 83 Brushy Fork Crossing, Buckhannon, WV 26201.

**7. VENDOR DEFAULT:**

**7.1** The following shall be considered a vendor default under this contract

**7.1.1** Failure to provide Contract Items in accordance with the requirements contained herein.

**REQUEST FOR QUOTATION**  
**CRFQ DOT1900000128**  
**(Class 371) 41,000 GVWR Single Axle Dump Truck w/ Snow Plow and V-Box Spreader**

---

- 7.1.2 Failure to comply with other specifications and requirements contained herein.
- 7.1.3 Failure to comply with any laws, rules, and ordinances applicable to the Contract Services provided under this Contract.
- 7.1.4 Failure to remedy deficient performance upon request.

7.2 The following remedies shall be available to Agency upon default.

- 7.2.1 Immediate cancellation of the Contract.
- 7.2.2 Immediate cancellation of one or more release orders issued under this Contract.
- 7.2.3 Any other remedies available in law or equity.

**8. MISCELLANEOUS:**

8.1 **No Substitutions:** Vendor shall supply only Contract Items submitted in response to RFQ unless a contract modification is approved in accordance with the provisions contained in this contract.

8.2 **Reports:** Vendor shall provide quarterly reports and annual summaries to the Agency showing the Agency's items purchased, quantities of items purchased, and total dollar value of the items purchased. Vendor shall also provide reports, upon request, showing the items purchased during the term of this Contract, the quantity purchased for each of those items, and the total value of purchases for each of those items. Failure to supply such reports may be grounds for cancellation of this Contract.

8.3 **Contract Manager:** During its performance of this Contract, Vendor must designate and maintain a primary contract manager responsible for overseeing Vendor's responsibilities under this Contract. The Contract manager must be available during normal business hours to address any customer service or other issues related to this Contract. Vendor should list its Contract manager and his or her contact information below.

**Contract Manager:**     Matt Cochran      
**Telephone Number:**     304-208-2542      
**Fax Number:**     304-759-9807      
**Email Address:**     matt.cochran@thetruckpeople.com



EXHIBIT C

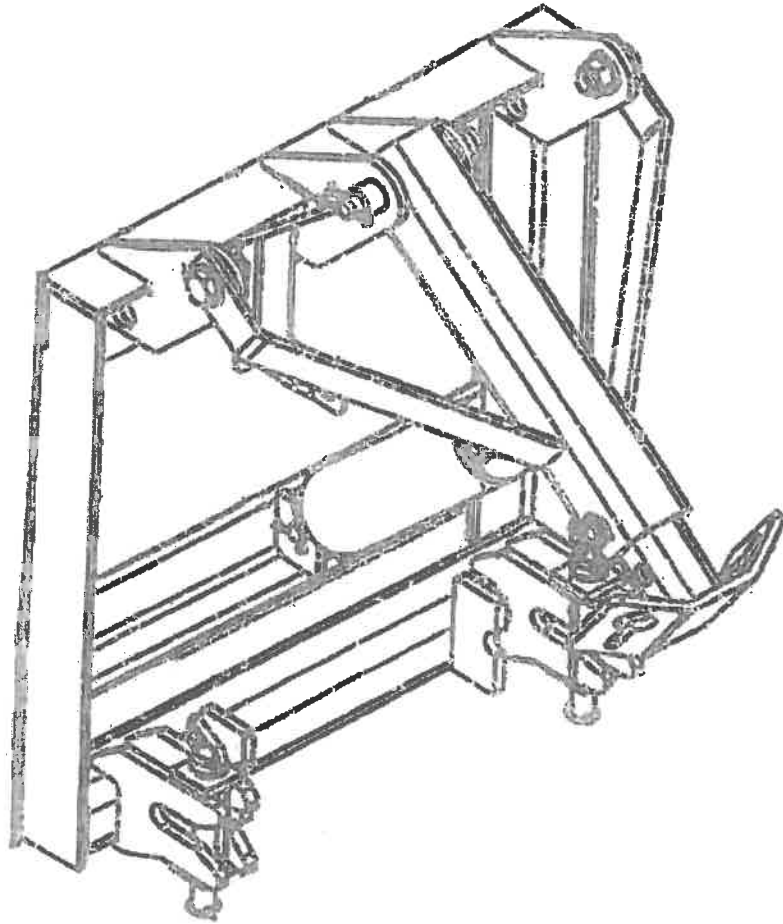

**WVDOH Plow Quick Hitch**

## West Virginia Ethics Commission



### Disclosure of Interested Parties to Contracts

Pursuant to *W. Va. Code* § 6D-1-2, a state agency may not enter into a contract, or a series of related contracts, that has/have an actual or estimated value of \$1 million or more until the business entity submits to the contracting state agency a Disclosure of Interested Parties to the applicable contract. In addition, the business entity awarded a contract is obligated to submit a supplemental Disclosure of Interested Parties reflecting any new or differing interested parties to the contract within 30 days following the completion or termination of the applicable contract.

For purposes of complying with these requirements, the following definitions apply:

**"Business entity"** means any entity recognized by law through which business is conducted, including a sole proprietorship, partnership or corporation, but does not include publicly traded companies listed on a national or international stock exchange.

**"Interested party" or "Interested parties"** means:

- (1) A business entity performing work or service pursuant to, or in furtherance of, the applicable contract, including specifically sub-contractors;
- (2) the person(s) who have an ownership interest equal to or greater than 25% in the business entity performing work or service pursuant to, or in furtherance of, the applicable contract. (This subdivision does not apply to a publicly traded company); and
- (3) the person or business entity, if any, that served as a compensated broker or intermediary to actively facilitate the applicable contract or negotiated the terms of the applicable contract with the state agency. (This subdivision does not apply to persons or business entities performing legal services related to the negotiation or drafting of the applicable contract.)

**"State agency"** means a board, commission, office, department or other agency in the executive, judicial or legislative branch of state government, including publicly funded institutions of higher education: Provided, that for purposes of *W. Va. Code* § 6D-1-2, the West Virginia Investment Management Board shall not be deemed a state agency nor subject to the requirements of that provision.

The contracting business entity must complete this form and submit it to the contracting state agency prior to contract award and to complete another form within 30 days of contract completion or termination.

*This form was created by the State of West Virginia Ethics Commission, 210 Brooks Street, Suite 300, Charleston, WV 25301-1804. Telephone: (304)558-0864; fax: (304)558-2169; e-mail: [ethics@wv.gov](mailto:ethics@wv.gov); website: [www.ethics.wv.gov](http://www.ethics.wv.gov).*

**West Virginia Ethics Commission**  
**Disclosure of Interested Parties to Contracts**  
(Required by W. Va. Code § 8D-1-2)

Name of Contracting Business Entity: \_\_\_\_\_ Address: \_\_\_\_\_

Name of Authorized Agent: \_\_\_\_\_ Address: \_\_\_\_\_

Contract Number: \_\_\_\_\_ Contract Description: \_\_\_\_\_

Governmental agency awarding contract: \_\_\_\_\_

Check here if this is a Supplemental Disclosure

List the Names of Interested Parties to the contract which are known or reasonably anticipated by the contracting business entity for each category below (*attach additional pages if necessary*):

1. Subcontractors or other entities performing work or service under the Contract

Check here if none, otherwise list entity/individual names below.

2. Any person or entity who owns 25% or more of contracting entity (not applicable to publicly traded entities)

Check here if none, otherwise list entity/individual names below.

3. Any person or entity that facilitated, or negotiated the terms of, the applicable contract (excluding legal services related to the negotiation or drafting of the applicable contract)

Check here if none, otherwise list entity/individual names below.

Signature:  Date Signed: 7/16/19

**Notary Verification**

State of West Virginia County of Kanawha:

I, Matt Cochran, the authorized agent of the contracting business entity listed above, being duly sworn, acknowledge that the Disclosure herein is being made under oath and under the penalty of perjury.

Taken, sworn to and subscribed before me this 16<sup>th</sup> day of July, 2019

  
Notary Public's Signature

**To be completed by State Agency:**  
Date Received by State Agency: \_\_\_\_\_  
Date submitted to Ethics Commission: \_\_\_\_\_  
Governmental agency submitting Disclosure: \_\_\_\_\_

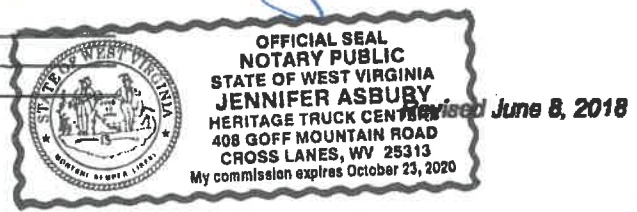

STATE OF WEST VIRGINIA  
Purchasing Division

# PURCHASING AFFIDAVIT

**CONSTRUCTION CONTRACTS:** Under W. Va. Code § 5-22-1(l), the contracting public entity shall not award a construction contract to any bidder that is known to be in default on any monetary obligation owed to the state or a political subdivision of the state, including, but not limited to, obligations related to payroll taxes, property taxes, sales and use taxes, fire service fees, or other fines or fees.

**ALL CONTRACTS:** Under W. Va. Code §5A-3-10a, no contract or renewal of any contract may be awarded by the state or any of its political subdivisions to any vendor or prospective vendor when the vendor or prospective vendor or a related party to the vendor or prospective vendor is a debtor and: (1) the debt owed is an amount greater than one thousand dollars in the aggregate; or (2) the debtor is in employer default.

**EXCEPTION:** The prohibition listed above does not apply where a vendor has contested any tax administered pursuant to chapter eleven of the W. Va. Code, workers' compensation premium, permit fee or environmental fee or assessment and the matter has not become final or where the vendor has entered into a payment plan or agreement and the vendor is not in default of any of the provisions of such plan or agreement.

**DEFINITIONS:**

"Debt" means any assessment, premium, penalty, fine, tax or other amount of money owed to the state or any of its political subdivisions because of a judgment, fine, permit violation, license assessment, defaulted workers' compensation premium, penalty or other assessment presently delinquent or due and required to be paid to the state or any of its political subdivisions, including any interest or additional penalties accrued thereon.

"Employer default" means having an outstanding balance or liability to the old fund or to the uninsured employers' fund or being in policy default, as defined in W. Va. Code § 23-2c-2, failure to maintain mandatory workers' compensation coverage, or failure to fully meet its obligations as a workers' compensation self-insured employer. An employer is not in employer default if it has entered into a repayment agreement with the Insurance Commissioner and remains in compliance with the obligations under the repayment agreement.

"Related party" means a party, whether an individual, corporation, partnership, association, limited liability company or any other form or business association or other entity whatsoever, related to any vendor by blood, marriage, ownership or contract through which the party has a relationship of ownership or other interest with the vendor so that the party will actually or by effect receive or control a portion of the benefit, profit or other consideration from performance of a vendor contract with the party receiving an amount that meets or exceeds five percent of the total contract amount.

**AFFIRMATION:** By signing this form, the vendor's authorized signer affirms and acknowledges under penalty of law for false swearing (W. Va. Code §61-5-3) that: (1) for construction contracts, the vendor is not in default on any monetary obligation owed to the state or a political subdivision of the state, and (2) for all other contracts, that neither vendor nor any related party owe a debt as defined above and that neither vendor nor any related party are in employer default as defined above, unless the debt or employer default is permitted under the exception above.

**WITNESS THE FOLLOWING SIGNATURE:**

Vendor's Name: Worldwide Equipment

Authorized Signature: [Signature] Date: 7/15/19

State of West Virginia

County of Kanawha, to-wit:

Taken, subscribed, and sworn to before me this 15<sup>th</sup> day of July, 2019.

My Commission expires 10/23/2020, 2020

AFFIX SEAL HERE

NOTARY PUBLIC [Signature]  
*Purchasing Affidavit (Revised 01/19/2018)*





Purchasing Division  
 2019 Washington Street East  
 Post Office Box 50130  
 Charleston, WV 25305-0130

State of West Virginia  
 Request for Quotation  
 19 - Highways

Proc Folder: 589305

Doc Description: ADDENDUM 1 41K GVWR SINGLE AXLE DUMP TRUCK (7019EC16)

Proc Type: Central Master Agreement

| Date Issued | Solicitation Closes    | Solicitation No         | Version |
|-------------|------------------------|-------------------------|---------|
| 2019-07-03  | 2019-07-17<br>13:30:00 | CRFQ 0803 DOT1900000128 | 2       |

**BID RECEIVING LOCATION**

BID CLERK  
 DEPARTMENT OF ADMINISTRATION  
 PURCHASING DIVISION  
 2019 WASHINGTON ST E  
 CHARLESTON WV 25305  
 US

**VENDOR**

Vendor Name, Address and Telephone Number:

Worldwide Equipment  
 5650 US Route 60 East  
 Huntington, WV 25705  
 304-345-2490

**FOR INFORMATION CONTACT THE BUYER**

Crystal G Hustead  
 (304) 558-2402  
 crystal.g.hustead@wv.gov

Signature X

FEIN # 45-1024981

DATE 7/16/19

All offers subject to all terms and conditions contained in this solicitation

**ADDITIONAL INFORMATION:**

THE WEST VIRGINIA PURCHASING DIVISION IS SOLICITING BIDS ON BEHALF OF THE WEST VIRGINIA DIVISION OF HIGHWAYS, DEPARTMENT OF TRANSPORTATION, TO ESTABLISH AN OPEN-END CONTRACT FOR A 41,000 GVWR SINGLE AXLE DUMP TRUCK WITH SNOW PLOW AND V-BOX SPREADER PER THE ATTACHED DOCUMENTS.

| INVOICE TO  |  | SHIP TO   |  |
|---|--|---|--|
| DIVISION OF HIGHWAYS<br>EQUIPMENT DIVISION RT 33<br>83 BRUSHY ROAD CROSSING, PO BOX 610<br>BUCKHANNON WV26201<br>US |  | DIVISION OF HIGHWAYS<br>EQUIPMENT DIVISION<br>83 BRUSHY FORK RD CROSSING<br>BUCKHANNON WV 26201<br>US |  |

| Line | Comm Ln Desc                 | Qty       | Unit Issue | Unit Price | Total Price |
|------|------------------------------|-----------|------------|------------|-------------|
| 1    | 41,000 GVWR Single Axle Dump | 120.00000 | EA         |            |             |

| Comm Code | Manufacturer | Specification | Model # |
|-----------|--------------|---------------|---------|
| 25101601  |              |               |         |

**Extended Description :**

41,000 GVWR Single Axle Dump Truck w/snowplow and V-Box Spreader

| INVOICE TO  |  | SHIP TO   |  |
|---|--|---|--|
| DIVISION OF HIGHWAYS<br>EQUIPMENT DIVISION RT 33<br>83 BRUSHY ROAD CROSSING, PO BOX 610<br>BUCKHANNON WV26201<br>US |  | DIVISION OF HIGHWAYS<br>EQUIPMENT DIVISION<br>83 BRUSHY FORK RD CROSSING<br>BUCKHANNON WV 26201<br>US |  |

| Line | Comm Ln Desc          | Qty       | Unit Issue | Unit Price | Total Price |
|------|-----------------------|-----------|------------|------------|-------------|
| 2    | FRONT 10FT. SNOW PLOW | 120.00000 | EA         |            |             |

| Comm Code | Manufacturer | Specification | Model # |
|-----------|--------------|---------------|---------|
| 25101601  |              |               |         |

**Extended Description :**

FRONT 10FT. SNOW PLOW

| INVOICE TO  |  | SHIP TO   |  |
|---|--|---|--|
| DIVISION OF HIGHWAYS<br>EQUIPMENT DIVISION RT 33<br>83 BRUSHY ROAD CROSSING, PO BOX 610<br>BUCKHANNON WV26201<br>US |  | DIVISION OF HIGHWAYS<br>EQUIPMENT DIVISION<br>83 BRUSHY FORK RD CROSSING<br>BUCKHANNON WV 26201<br>US |  |

| Line | Comm Ln Desc          | Qty       | Unit Issue | Unit Price | Total Price |
|------|-----------------------|-----------|------------|------------|-------------|
| 3    | FRONT 11FT. SNOW PLOW | 120.00000 | EA         |            |             |

| Comm Code | Manufacturer | Specification | Model # |
|-----------|--------------|---------------|---------|
| 25101601  |              |               |         |

Extended Description :  
FRONT 11FT. SNOW PLOW

| INVOICE TO  | SHIP TO   |
|---|---|
| DIVISION OF HIGHWAYS<br>EQUIPMENT DIVISION RT 33<br>83 BRUSHY ROAD CROSSING, PO BOX 610<br>BUCKHANNON WV26201<br>US | DIVISION OF HIGHWAYS<br>EQUIPMENT DIVISION<br>83 BRUSHY FORK RD CROSSING<br>BUCKHANNON WV 26201<br>US |

| Line | Comm Ln Desc   | Qty       | Unit Issue | Unit Price | Total Price |
|------|----------------|-----------|------------|------------|-------------|
| 4    | V-BOX SPREADER | 120.00000 | EA         |            |             |

| Comm Code | Manufacturer | Specification | Model # |
|-----------|--------------|---------------|---------|
| 25101601  |              |               |         |

Extended Description :  
V-BOX SPREADER

| SCHEDULE OF EVENTS |                           |            |
|--------------------|---------------------------|------------|
| Line               | Event                     | Event Date |
| 1                  | MANDATORY PRE-BID MEETING | 2019-06-25 |
| 2                  | VENDOR QUESTION DEADLINE  | 2019-06-28 |

|                      |                                |   |                              |
|----------------------|--------------------------------|---|------------------------------|
| <b>DOT1900000128</b> | <b>Document Phase</b><br>Final | <b>Document Description</b><br>ADDENDUM 1 41K GVWR SINGLE AXLE<br>DUMP TRUCK (7019EC16) | <b>Page 4</b><br><b>of 4</b> |
|----------------------|--------------------------------|---|------------------------------|

**ADDITIONAL TERMS AND CONDITIONS**

See attached document(s) for additional Terms and Conditions



**ADDITIONAL INFORMATION:**

THE WEST VIRGINIA PURCHASING DIVISION IS SOLICITING BIDS ON BEHALF OF THE WEST VIRGINIA DIVISION OF HIGHWAYS, DEPARTMENT OF TRANSPORTATION, TO ESTABLISH AN OPEN-END CONTRACT FOR A 41,000 GVWR SINGLE AXLE DUMP TRUCK WITH SNOW PLOW AND V-BOX SPREADER PER THE ATTACHED DOCUMENTS.

| INVOICE TO  |  | SHIP TO   |  |
|---|--|---|--|
| DIVISION OF HIGHWAYS<br>EQUIPMENT DIVISION RT 33<br>83 BRUSHY ROAD CROSSING, PO BOX 610<br>BUCKHANNON WV26201<br>US |  | DIVISION OF HIGHWAYS<br>EQUIPMENT DIVISION<br>83 BRUSHY FORK RD CROSSING<br>BUCKHANNON WV 26201<br>US |  |

| Line | Comm Ln Desc                 | Qty       | Unit Issue | Unit Price | Total Price |
|------|------------------------------|-----------|------------|------------|-------------|
| 1    | 41,000 GVWR Single Axle Dump | 120.00000 | EA         |            |             |

| Comm Code | Manufacturer | Specification | Model # |
|-----------|--------------|---------------|---------|
| 25101601  |              |               |         |

**Extended Description :**  
41,000 GVWR Single Axle Dump Truck w/snowplow and V-Box Spreader

| INVOICE TO  |  | SHIP TO   |  |
|---|--|---|--|
| DIVISION OF HIGHWAYS<br>EQUIPMENT DIVISION RT 33<br>83 BRUSHY ROAD CROSSING, PO BOX 610<br>BUCKHANNON WV26201<br>US |  | DIVISION OF HIGHWAYS<br>EQUIPMENT DIVISION<br>83 BRUSHY FORK RD CROSSING<br>BUCKHANNON WV 26201<br>US |  |

| Line | Comm Ln Desc          | Qty       | Unit Issue | Unit Price | Total Price |
|------|-----------------------|-----------|------------|------------|-------------|
| 2    | FRONT 10FT. SNOW PLOW | 120.00000 | EA         |            |             |

| Comm Code | Manufacturer | Specification | Model # |
|-----------|--------------|---------------|---------|
| 25101601  |              |               |         |

**Extended Description :**  
FRONT 10FT. SNOW PLOW

| INVOICE TO  |  | SHIP TO   |  |
|---|--|---|--|
| DIVISION OF HIGHWAYS<br>EQUIPMENT DIVISION RT 33<br>83 BRUSHY ROAD CROSSING, PO BOX 610<br>BUCKHANNON WV26201<br>US |  | DIVISION OF HIGHWAYS<br>EQUIPMENT DIVISION<br>83 BRUSHY FORK RD CROSSING<br>BUCKHANNON WV 26201<br>US |  |

| Line | Comm Ln Desc          | Qty       | Unit Issue | Unit Price | Total Price |
|------|-----------------------|-----------|------------|------------|-------------|
| 3    | FRONT 11FT. SNOW PLOW | 120.00000 | EA         |            |             |

| Comm Code | Manufacturer | Specification | Model # |
|-----------|--------------|---------------|---------|
| 25101601  |              |               |         |

Extended Description :  
FRONT 11FT. SNOW PLOW

| INVOICE TO  | SHIP TO   |
|---|---|
| DIVISION OF HIGHWAYS<br>EQUIPMENT DIVISION RT 33<br>83 BRUSHY ROAD CROSSING, PO BOX 610<br>BUCKHANNON WV26201<br>US | DIVISION OF HIGHWAYS<br>EQUIPMENT DIVISION<br>83 BRUSHY FORK RD CROSSING<br>BUCKHANNON WV 26201<br>US |

| Line | Comm Ln Desc   | Qty       | Unit Issue | Unit Price | Total Price |
|------|----------------|-----------|------------|------------|-------------|
| 4    | V-BOX SPREADER | 120.00000 | EA         |            |             |

| Comm Code | Manufacturer | Specification | Model # |
|-----------|--------------|---------------|---------|
| 25101601  |              |               |         |

Extended Description :  
V-BOX SPREADER

| SCHEDULE OF EVENTS |  |  |
|--------------------|--|--|
|--------------------|--|--|

| Line | Event                     | Event Date |
|------|---------------------------|------------|
| 1    | MANDATORY PRE-BID MEETING | 2019-06-25 |
| 2    | VENDOR QUESTION DEADLINE  | 2019-06-28 |

**SOLICITATION NUMBER: CRFQ DOT1900000128**

**Addendum Number: 1**

---

The purpose of this addendum is to modify the solicitation identified as ("Solicitation") to reflect the change(s) identified and described below.

**Applicable Addendum Category:**

- Modify bid opening date and time
- Modify specifications of product or service being sought
- Attachment of vendor questions and responses
- Attachment of pre-bid sign-in sheet
- Correction of error
- Other

**Description of Modification to Solicitation:**

1. To extend the bid opening date to July 17, 2019 at 1:30 PM EST
2. To provide the pre-bid meeting sign-in sheets

\*\*\*Answers to vendor questions will be addressed in a forthcoming addendum\*\*\*

No other changes at this time

**Additional Documentation:** Documentation related to this Addendum (if any) has been included herewith as Attachment A and is specifically incorporated herein by reference.

**Terms and Conditions:**

1. All provisions of the Solicitation and other addenda not modified herein shall remain in full force and effect.
2. Vendor should acknowledge receipt of all addenda issued for this Solicitation by completing an Addendum Acknowledgment, a copy of which is included herewith. Failure to acknowledge addenda may result in bid disqualification. The addendum acknowledgement should be submitted with the bid to expedite document processing.

# ATTACHMENT A

**PRE-BID CONFERENCE  
SIGN IN SHEET**

Request for Quotation Number: CRFQ DOT1900000128

Date: 6/25/19

Project Description: Single Axle Dump Truck

**LEASE PRINT LEGIBLY. THIS INFORMATION IS ESSENTIAL TO CONTACT THE ATTENDEES IN A TIMELY MANNER. FAILURE TO DO SO MAY RESULT IN DELAYS IN YOUR COMPANY GETTING IMPORTANT BID INFORMATION.**

Firm Name: Viking Cycles Midwest  
 Firm Address: PO Box 295 Morley  
MO 63767  
 Representative Attending: Scott Boyer  
 Phone Number: 314-471-5261  
 Fax Number:  
 Email Address: Sboyer@Vikingcyclesmidwest.com

Firm Name: NEWTONS INTERNATIONAL SALES, LLC  
 Firm Address: PO Box 1334  
ELKINS, WV 26241  
 Representative Attending: BEAU NEWTON  
 Phone Number: 304-614-0469  
 Fax Number: 304-636-7153  
 Email Address: BEAU@NEWTONWV.COM

Firm Name: Worldwide Equipment  
 Firm Address: 405 New Golf Mtn. Rd  
Cross Lanes WV 25313  
 Representative Attending: Matt Cochran  
 Phone Number: 304-208-2542  
 Fax Number:  
 Email Address: Matt.Cochran@thetruckpeople.com

Firm Name:  
 Firm Address: JEFF PIFER  
DoH  
 Representative Attending:  
 Phone Number:  
 Fax Number:  
 Email Address:

Firm Name: NAUISTAR INC.  
 Firm Address: # 5361 Red Leaf Ct.  
QUIEDO, FL 32765  
 Representative Attending: PETER McGRATH  
 Phone Number: 407-761-3305  
 Fax Number:  
 Email Address: Peter.McGRATH@NAUISTAR.COM

Firm Name:  
 Firm Address:  
 Representative Attending:  
 Phone Number:  
 Fax Number:  
 Email Address:

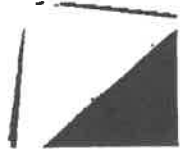

**PKE-BID CONFERENCE  
SIGN IN SHEET**

Request for Quotation Number: CRFQ DOT1900000128

Date: 6/25/19

Project Description: Single Axle Dump Truck

**PLEASE PRINT LEGIBLY. THIS INFORMATION IS ESSENTIAL TO CONTACT THE ATTENDEES IN A TIMELY MANNER. FAILURE TO DO SO MAY RESULT IN DELAYS IN YOUR COMPANY GETTING IMPORTANT BID INFORMATION.**

|                           |  |
|---------------------------|--|
| Firm Name:                | <u>MONROE Truck Equipment</u>              |
| Firm Address:             | <u>1051 W. 7th St<br/>Monroe, WI 53566</u> |
| Representative Attending: | <u>John Bernal</u>                         |
| Phone Number:             | <u>1 608-214-3533</u>                      |
| Fax Number:               |  |
| Email Address:            | <u>thbeaver@monroetruck.com</u>            |

|                           |   |
|---------------------------|---|
| Firm Name:                | <u>MATHELY MOTOR TRUCK COMPANY</u>                |
| Firm Address:             | <u>P O BOX 1384<br/>PARKERSBURG WV 26102-1384</u> |
| Representative Attending: | <u>MIKE MATHELY</u>                               |
| Phone Number:             | <u>304-483-4418 X 6601</u>                        |
| Fax Number:               | <u>304-483-2577</u>                               |
| Email Address:            | <u>mmathely@mathelymotors.com</u>                 |

|                           |   |
|---------------------------|---|
| Firm Name:                | <u>MATHELY MOTOR TRUCK</u>                        |
| Firm Address:             | <u>50 MATHELY CAMP<br/>MUNERAL WELLS WV 26156</u> |
| Representative Attending: | <u>Jack Cummings</u>                              |
| Phone Number:             | <u>304-769-5860 X 3601</u>                        |
| Fax Number:               | <u>304-769-5866</u>                               |
| Email Address:            | <u>jcummings@mathelymotor.com</u>                 |

|                           |                   |
|---------------------------|-------------------|
| Firm Name:                |                   |
| Firm Address:             | <u>WV DOT</u>     |
| Representative Attending: | <u>Tina Lewis</u> |
| Phone Number:             |                   |
| Fax Number:               |                   |
| Email Address:            |                   |

|                           |   |
|---------------------------|---|
| Firm Name:                | <u>Certified Power Solutions</u>                      |
| Firm Address:             | <u>26495 Southpoint Road<br/>Perrysburg, OH 43551</u> |
| Representative Attending: | <u>Bill Carey</u>                                     |
| Phone Number:             | <u>717 350 0258</u>                                   |
| Fax Number:               | <u>806-620-6020</u>                                   |
| Email Address:            | <u>wcarey@certifiedpower.com</u>                      |

|                           |  |
|---------------------------|--|
| Firm Name:                |  |
| Firm Address:             |  |
| Representative Attending: |  |
| Phone Number:             |  |
| Fax Number:               |  |
| Email Address:            |  |

**PRE-BID CONFERENCE  
SIGN IN SHEET**

Request for Quotation Number: CRFQ DOT1900000128

Date: 6/25/19

Project Description: Single Axle Dump Truck

**PLEASE PRINT LEGIBLY. THIS INFORMATION IS ESSENTIAL TO CONTACT THE ATTENDEES IN A TIMELY MANNER. FAILURE TO DO SO MAY RESULT IN DELAYS IN YOUR COMPANY GETTING IMPORTANT BID INFORMATION.**

|                           |  |
|---------------------------|--|
| Firm Name:                | <u>ACE TRUCK Equip</u>                             |
| Firm Address:             | <u>PO Box 2605</u><br><u>Zanesville Ohio 45702</u> |
| Representative Attending: | <u>DAVID BETZEL</u>                                |
| Phone Number:             | <u>740 4530551</u>                                 |
| Fax Number:               | <u>740 4537023</u>                                 |
| Email Address:            | <u>DAVID@ACETRUCK.NET</u>                          |

|                           |       |
|---------------------------|-------|
| Firm Name:                | _____ |
| Firm Address:             | _____ |
| Representative Attending: | _____ |
| Phone Number:             | _____ |
| Fax Number:               | _____ |
| Email Address:            | _____ |

|                           |  |
|---------------------------|--|
| Firm Name:                | <u>Henderson Products, Inc.</u>                |
| Firm Address:             | <u>PO Box 811</u><br><u>Buckeye, OH. 44820</u> |
| Representative Attending: | <u>Dan Perry</u>                               |
| Phone Number:             | <u>419-617-7509</u>                            |
| Fax Number:               | <u>563-927-7161</u>                            |
| Email Address:            | <u>dperry@hendersonproducts.com</u>            |

|                           |       |
|---------------------------|-------|
| Firm Name:                | _____ |
| Firm Address:             | _____ |
| Representative Attending: | _____ |
| Phone Number:             | _____ |
| Fax Number:               | _____ |
| Email Address:            | _____ |

|                           |   |
|---------------------------|---|
| Firm Name:                | <u>J &amp; T Fabricating Trailers, Inc</u>          |
| Firm Address:             | <u>801 Ragland Blvd</u><br><u>Berkley, OH 25801</u> |
| Representative Attending: | <u>Keith G. Stevens</u>                             |
| Phone Number:             | <u>304-255-1441</u>                                 |
| Fax Number:               | <u>304-255-0516</u>                                 |
| Email Address:            | <u>Keith@jandjfabwv.com</u>                         |

|                           |       |
|---------------------------|-------|
| Firm Name:                | _____ |
| Firm Address:             | _____ |
| Representative Attending: | _____ |
| Phone Number:             | _____ |
| Fax Number:               | _____ |
| Email Address:            | _____ |

**PRE-BID CONFERENCE  
SIGN IN SHEET**

Request for Quotation Number: CRFO DOT1900000128

Date: 6/25/19

Project Description: Single Axle Dump Truck

**PLEASE PRINT LEGIBLY. THIS INFORMATION IS ESSENTIAL TO CONTACT THE ATTENDEES IN A TIMELY MANNER. FAILURE TO DO SO MAY RESULT IN DELAYS IN YOUR COMPANY GETTING IMPORTANT BID INFORMATION.**

|                           |                                 |
|---------------------------|---------------------------------|
| Firm Name:                | <u>CLARKSBURG MACK SAS</u>      |
| Firm Address:             | <u>1481 SHANNON PIKE</u>        |
|                           | <u>CLARKSBURG, WV</u>           |
|                           | <u>26301</u>                    |
| Representative Attending: | <u>Jerry Armentrout</u>         |
| Phone Number:             | <u>304 203.5007</u>             |
| Fax Number:               | <u>304 622.2908</u>             |
| Email Address:            | <u>jerry@clarksburgmack.com</u> |

|                           |                  |
|---------------------------|------------------|
| Firm Name:                |                  |
| Firm Address:             | <u>JJ Haller</u> |
|                           | <u>WV DOT</u>    |
| Representative Attending: |                  |
| Phone Number:             |                  |
| Fax Number:               |                  |
| Email Address:            |                  |

|                           |                 |
|---------------------------|-----------------|
| Firm Name:                |                 |
| Firm Address:             | <u>Pam Hall</u> |
|                           | <u>WV DOT</u>   |
| Representative Attending: |                 |
| Phone Number:             |                 |
| Fax Number:               |                 |
| Email Address:            |                 |

|                           |                  |
|---------------------------|------------------|
| Firm Name:                |                  |
| Firm Address:             | <u>Maria Lee</u> |
|                           | <u>DOT</u>       |
| Representative Attending: |                  |
| Phone Number:             |                  |
| Fax Number:               |                  |
| Email Address:            |                  |

|                           |                    |
|---------------------------|--------------------|
| Firm Name:                | <u>Todd Rybell</u> |
| Firm Address:             | <u>WV DOT</u>      |
| Representative Attending: |                    |
| Phone Number:             |                    |
| Fax Number:               |                    |
| Email Address:            |                    |

|                           |                   |
|---------------------------|-------------------|
| Firm Name:                |                   |
| Firm Address:             | <u>Tim J. Ray</u> |
|                           | <u>DOT</u>        |
| Representative Attending: |                   |
| Phone Number:             |                   |
| Fax Number:               |                   |
| Email Address:            |                   |



## Keith G. Stevens

Director of Sales and Marketing

801 Ragland Road  
Beckley, WV 25801

tel (304) 255-1441  
fax (304) 255-0516  
keith@jandjfabwv.com  
www.jandjfabwv.com



## Henderson

Dan Perry  
Sales Manager

HENDERSON PRODUCTS, INC. Parts & Service: (800) 359-4970  
2177 State Rte 19 Office: (419) 617-7509  
PO Box 811 Cell: (440) 226-4690  
Bucyrus, OH 44820 Fax: (563) 927-7161

E-mail: dperry@hendersonproducts.com  
www.hendersonproducts.com



26495 Southpoint Road  
Perrysburg, OH 43551  
cell: (717) 350-0258  
toll free: (800) 374-7411  
fax: (866) 620-6820  
wcarey@certifiedcirrus.com  
www.certifiedcirrus.com

William Carey  
Territory Sales Manager

Peter McGrath  
Vocational Sales Manager  
Government

Navistar, Inc.  
5361 Red Leaf Court  
Oviedo, FL 32765 USA

T: 407-761-3305  
E: peter.mcgrath@navistar.com



A NAVISTAR COMPANY

Monroe Truck Equipment  
1051 W. 7th Street  
Monroe, WI 53566

USA 800-880-0109  
MOBILE 608-214-3533  
FAX 608-328-8390

tboaver@monroetruck.com  
www.monroetruck.com



TONY BEAVER  
Regional Sales Manager  
Snow & Ice Control Division



22956 Highway 61 • Oran, MO 63771  
P.O. Box 295 • Morley, MO 63767

**VIKING GIVES**  
MIDWEST  
Scott Boyer  
Sales

Cell: 314-471-5261  
sboyer@vikinggivesmidwest.com

Phone: 573-262-354  
Fax: 573-262-336



## Beau Newlon

P.O. Box 1334  
16 Ward Road  
Elkins, WV 26241

T: 304-636-4561  
F: 304-636-7155  
M: 304-614-0469  
E: beau@newlonswv.com

WWW.NEWLONSINTERNATIONAL.COM

WWW.THETRUCKPEOPLE.COM

# ACE TRUCK EQUIPMENT

DISTRIBUTOR OF  
TRUCK BODIES  
TRAILERS

1130 NEWARK ROAD  
ZANESVILLE, OHIO 43701  
(740) 453-0551

David R. Beitzel



**JACK CUMMINGS**  
Sales Consultant

*Certified Master Sales Professional*

Matheny Motor Truck Company  
4125 1st Ave  
Nitro, WV 25143  
304.539.3817 Phone  
jcummings@mathenymotors.com



**ADDENDUM ACKNOWLEDGEMENT FORM**  
**SOLICITATION NO.: DOT1900000128**

**Instructions:** Please acknowledge receipt of all addenda issued with this solicitation by completing this addendum acknowledgment form. Check the box next to each addendum received and sign below. Failure to acknowledge addenda may result in bid disqualification.

**Acknowledgment:** I hereby acknowledge receipt of the following addenda and have made the necessary revisions to my proposal, plans and/or specification, etc.

**Addendum Numbers Received:**  
(Check the box next to each addendum received)

- |  |  |
|--|--|
| <input checked="" type="checkbox"/> Addendum No. 1 | <input type="checkbox"/> Addendum No. 6  |
| <input checked="" type="checkbox"/> Addendum No. 2 | <input type="checkbox"/> Addendum No. 7  |
| <input type="checkbox"/> Addendum No. 3            | <input type="checkbox"/> Addendum No. 8  |
| <input type="checkbox"/> Addendum No. 4            | <input type="checkbox"/> Addendum No. 9  |
| <input type="checkbox"/> Addendum No. 5            | <input type="checkbox"/> Addendum No. 10 |

I understand that failure to confirm the receipt of addenda may be cause for rejection of this bid. I further understand that any verbal representation made or assumed to be made during any oral discussion held between Vendor's representatives and any state personnel is not binding. Only the information issued in writing and added to the specifications by an official addendum is binding.

Worldwide Equipment  
Company

  
Authorized Signature

7/16/19  
Date

**NOTE:** This addendum acknowledgment should be submitted with the bid to expedite document processing.  
Revised 6/8/2012

**ADDITIONAL INFORMATION:**

THE WEST VIRGINIA PURCHASING DIVISION IS SOLICITING BIDS ON BEHALF OF THE WEST VIRGINIA DIVISION OF HIGHWAYS, DEPARTMENT OF TRANSPORTATION, TO ESTABLISH AN OPEN-END CONTRACT FOR A 41,000 GVWR SINGLE AXLE DUMP TRUCK WITH SNOW PLOW AND V-BOX SPREADER PER THE ATTACHED DOCUMENTS.

| INVOICE TO  |  | SHIP TO   |  |
|---|--|---|--|
| DIVISION OF HIGHWAYS<br>EQUIPMENT DIVISION RT 33<br>83 BRUSHY ROAD CROSSING, PO BOX 610<br>BUCKHANNON WV26201<br>US |  | DIVISION OF HIGHWAYS<br>EQUIPMENT DIVISION<br>83 BRUSHY FORK RD CROSSING<br>BUCKHANNON WV 26201<br>US |  |

| Line | Comm Ln Desc          | Qty       | Unit Issue | Unit Price | Total Price |
|------|-----------------------|-----------|------------|------------|-------------|
| 1    | CAB CHASSIS/DUMP BODY | 120.00000 | EA         |            |             |

| Comm Code | Manufacturer | Specification | Model # |
|-----------|--------------|---------------|---------|
| 25101601  |              |               |         |

Extended Description :  
 CAB CHASSIS/DUMP BODY WITH HYD. AND SPREADER CONTROL SYSTEM

| INVOICE TO  |  | SHIP TO   |  |
|---|--|---|--|
| DIVISION OF HIGHWAYS<br>EQUIPMENT DIVISION RT 33<br>83 BRUSHY ROAD CROSSING, PO BOX 610<br>BUCKHANNON WV26201<br>US |  | DIVISION OF HIGHWAYS<br>EQUIPMENT DIVISION<br>83 BRUSHY FORK RD CROSSING<br>BUCKHANNON WV 26201<br>US |  |

| Line | Comm Ln Desc          | Qty       | Unit Issue | Unit Price | Total Price |
|------|-----------------------|-----------|------------|------------|-------------|
| 2    | FRONT 10FT. SNOW PLOW | 120.00000 | EA         |            |             |

| Comm Code | Manufacturer | Specification | Model # |
|-----------|--------------|---------------|---------|
| 25101601  |              |               |         |

Extended Description :  
 FRONT 10FT. SNOW PLOW WITH PLOW MOUNT

| INVOICE TO  |  | SHIP TO   |  |
|---|--|---|--|
| DIVISION OF HIGHWAYS<br>EQUIPMENT DIVISION RT 33<br>83 BRUSHY ROAD CROSSING, PO BOX 610<br>BUCKHANNON WV26201<br>US |  | DIVISION OF HIGHWAYS<br>EQUIPMENT DIVISION<br>83 BRUSHY FORK RD CROSSING<br>BUCKHANNON WV 26201<br>US |  |

| Line | Comm Ln Desc          | Qty       | Unit Issue | Unit Price | Total Price |
|------|-----------------------|-----------|------------|------------|-------------|
| 3    | FRONT 11FT. SNOW PLOW | 120.00000 | EA         |            |             |

| Comm Code | Manufacturer | Specification | Model # |
|-----------|--------------|---------------|---------|
| 25101601  |              |               |         |

Extended Description :  
FRONT 11FT. SNOW PLOW WITH PLOW MOUNT

| INVOICE TO  | SHIP TO   |
|---|---|
| DIVISION OF HIGHWAYS<br>EQUIPMENT DIVISION RT 33<br>83 BRUSHY ROAD CROSSING, PO BOX 610<br>BUCKHANNON WV26201<br>US | DIVISION OF HIGHWAYS<br>EQUIPMENT DIVISION<br>83 BRUSHY FORK RD CROSSING<br>BUCKHANNON WV 26201<br>US |

| Line | Comm Ln Desc   | Qty       | Unit Issue | Unit Price | Total Price |
|------|----------------|-----------|------------|------------|-------------|
| 4    | V-BOX SPREADER | 120.00000 | EA         |            |             |

| Comm Code | Manufacturer | Specification | Model # |
|-----------|--------------|---------------|---------|
| 25101601  |              |               |         |

Extended Description :  
V-BOX SPREADER

| SCHEDULE OF EVENTS |  |  |
|--------------------|--|--|
|--------------------|--|--|

| Line | Event                     | Event Date |
|------|---------------------------|------------|
| 1    | MANDATORY PRE-BID MEETING | 2019-06-25 |
| 2    | VENDOR QUESTION DEADLINE  | 2019-06-28 |

**SOLICITATION NUMBER: CRFQ DOT1900000128**

**Addendum Number: 2**

---

The purpose of this addendum is to modify the solicitation identified as ("Solicitation") to reflect the change(s) identified and described below.

**Applicable Addendum Category:**

- Modify bid opening date and time
- Modify specifications of product or service being sought
- Attachment of vendor questions and responses
- Attachment of pre-bid sign-in sheet
- Correction of error
- Other

**Description of Modification to Solicitation:**

1. To provide REVISED Exhibit A Pricing Page
2. To provide answers to vendor questions

No other changes

Bid opening remains July 17, 2019 at 1:30 PM EST

**Additional Documentation:** Documentation related to this Addendum (if any) has been included herewith as Attachment A and is specifically incorporated herein by reference.

**Terms and Conditions:**

1. All provisions of the Solicitation and other addenda not modified herein shall remain in full force and effect.
2. Vendor should acknowledge receipt of all addenda issued for this Solicitation by completing an Addendum Acknowledgment, a copy of which is included herewith. Failure to acknowledge addenda may result in bid disqualification. The addendum acknowledgement should be submitted with the bid to expedite document processing.

# ATTACHMENT A

**CRFQ DOT1900000128**

**ADDENDUM 2**

**Single Axle Dump Truck**

**The original language in contract will be listed first with question and answer to follow below.**

**1. 3.1.4.3 Grille shall be fixed.**

**Question:** Would a non-stationary grille be acceptable if it does not interfere with plow and the lights during a pre-or post -inspection or during operation of unit.

**Answer: yes, will accept.**

---

**2. 3.1.6.1 Cab shall have minimum of one air horn cab mounted or under hood mounted with snow shield.**

**Question # 1:** Request clarification, does an under hood mounted airhorn also require a snow shield or just the roof mounted air horn option.

**Question # 2:** Same Identical question

**Answer: Will change to Read: 3.1.6.1 Cab shall have minimum of one air horn cab mounted with snow shield or under hood mounted without snow shield.**

---

**3. 3.1.6.13 Cab shall have six (4) additional switches.**

**Question # 1:** Request clarification, does the state require 4 or 6 spare switches? What are the additional switches to be used for?

**Question # 2:** Request clarification, does the state require 4 or 6 spare switches?

**Answer: Will change to read; 3.1.6.13 Cab shall have a minimum of (4) additional switches for extra work lights, driving lights, body vibrator etc...**

---

**4. 3.1.7.2 Engine Compression Brake: Must be full engine compression brake minimum 3 stages with selector switch and on/off power switch and shall be dash mounted.**



**Question # 1:** Will the agency consider a steering column mounted stalk control switch for the Engine Compression brake in lieu of dash mounted? All other functionality equal. See picture attached.

**Question # 2:** Will the state consider a steering column mounted stalk control switch for the Engine Compression brake in lieu of dash mounted? All other functionality equal.

**Answer: yes, will accept**

---

**5. 3.1.11.3** Shall have a transmission shift pad or shift lever with oil life monitor; filter life monitor and transmission health monitor, lighted and dash or console mounted.

**Question # 1:** Will the agency consider a steering column mounted stalk control switch for the Transmission control in lieu of dash mounted? All other functionality equal. See attached picture.

**Question # 2:** Will the state consider a steering column mounted stalk control switch for the Transmission control in lieu of dash mounted? All other functionality equal.

**Answer: yes, will accept**

---

**6. 3.1.23.1** The No Idle heat and Power System shall do and include the following:

- A.** The system shall be controlled by a touchscreen (user interface) Touchscreen will control electrical circuits specified in document E.
- B.** The system shall provide a dash display of battery voltage an audible alert when battery voltage needs to be replenished, and automatically disconnect the loads at a predetermined low voltage setting with use of a low voltage disconnect.
- C.** Shall power loads during no-idle conditions with deep cycle AGM batteries for a minimum of 6 hours.
- D.** Shall provide a minimum of 17,000 BTUs of heat for cab and engine.
- E.** Shall provide electrical power to heater blower motor and controls, parking lights, AM/FM radio weather band with wireless connectivity, WVDOH state 2way radio and emergency/ strobe lighting with key in auxiliary position.
- F.** Truck shall use electric start module for engine starting.
- G.** All AGM batteries and electronic start module shall be group 31 and fit in the OEM battery tray without modifications

**Question # 1:** Will the agency consider an Auto-therm T2500-D with a micro-processor controlled Auto start/stop and programmable load shedding functionality as an approved equivalent? Dash mounted user interface is not “Touchscreen.”

**Question # 2:** Will the state consider an Auto-therm T2500-D with a micro-processor controlled Auto start/stop and programmable load shedding functionality as an approved equivalent? Dash mounted user interface is not “Touchscreen.”

**Answer: yes, will accept**

---

**7. 3.2.5.4** Air operated tailgate shall be “pancake-type” tailgate release valve or equal.

**Question:** Will an air operated 3” double acting cylinder with over-center lock be considered equal?

**Answer: yes, will accept**

---

**8. 3.3.1.1** Moldboard Construction shall be 10-gauge steel and rolled to give the snow a free rolling action. Break formed will not be acceptable.

**3.3.1.1 D.O.H.- Will change to read 3.3.1.1:** Moldboard Construction shall be 12-gauge minimum, Domax steel material or 10-gauge minimum stainless steel and rolled to give the snow a free rolling action. Break formed will not be acceptable.

---

**9. 3.3.3.1** Shall be a Kueper Tuca model SX wave or equal

**Question:** Is there curb shoe requirement?

**Answer: yes, Will change to read: 3.3.3.1** Shall be a Kueper Tuca model SX wave 7-inch minimum cutting edge with curb shoe matched for cutting edge set at 15-degree angle or equal.

---

**10. 3.3.1.3** Overall height shall be a maximum of 32- inches.

**Question:** Does the 32” height include a cutting edge? If so, 6” or 8” cutting edge and at what attack angle is the moldboard set at?

**Answer Question #1: Will change to read: Overall height shall be a minimum of 29-inches and a maximum height of 32-inches with cutting edges installed.**

**Answer Question #2: REVISED LINE ITEM 3.3.1.3 was changed to read: 3.3.3.1**  
Shall be a Kueper Tuca model SX wave 7-inch minimum or equal with curb shoe matched for cutting edge set at 15-degree angle.

---

**11. 3.4.1.2** A Inside length to be 9.5 feet maximum and maximum height of 56".

**Question:** If the entire hopper assembly would fit into supplied dump body would an 120" hopper be accepted?

**Answer: yes**

---

**12. 3.4.1.18.1** Shall include LED stop, tail, turn, (3) LED bar light, Four (2) LED strobes and two (2) LED rear work lights.

**Question:** Should this be 2 or 4 amber strobes?

**Answer: Will change to read: Spreader shall include LED stop, tail, turn signal lights, (3) bar LED ID lights, Four (2) LED strobes and two (2) LED rear work lights.**

---

**13. 3.3.6.1.1** Cylinders shall be mounted above the semi-circle.

**D.O.H-Will change to read: 3.3.6.1.1** Cylinders shall be mounted above or below semi-circle.

---

**14. 3.5.2.1** (2) 200-gallon minimum rotation molded medium density .375" polyethylene tank with 5" diameter cap. Includes sump for complete drainage.

**Question # 1:** Would 2" npt pipe thread caps be acceptable?

**Question # 2:** Would a tank with molded in 1 ¼" ports at base be acceptable in place of sump?

**Answer: no, leave as written**

---

**15. 6.1 Delivery Time:** A completed pilot model for inspection must be provided within **120** working day(s) after receipt of the pilot model order, by the successful vendor. Vendor shall deliver standard orders within **180** working days after orders are received Working day is defined as any week day, Monday thru Friday, excluding Federal and State Holidays. Vendor shall ship all orders until a minimum delivery quantity is met.

**Question # 1:** Due to uncertainty in truck/body market, would the state consider a delivery time of 180 working days for pilot, and 240 working days for remaining?

**Question # 2:** Does the 180-day delivery start after approved pilot?

**Answer Q1:** will change to 180 on pilot and 240 on standard orders.

**Answer Q2:** See answer to Q.#1 180 on pilot from received orders, 240 days on balance of order from received order.

---

**16. Question:** Will all purchase orders be cut at one time or staggered over 3-4 months?

**Answer:** could be one or numerous orders

---

**17. Exhibit A** Estimated quantity 120 units.

**Question:** Is the estimated quantity yearly requirement or entire length of contract? or 120 units spread over four years?

**Answer:** Estimating 30 units per, year depending on Equipment budget.

---

**18. Exhibit A Pricing Page**

**Question:** Would the WVDOH please clarify the pricing required for the lines as shown on the pricing page 1 of Exhibit A.

**Line 1 Complete unit:** Cab Chassis/Dump Body w/Hydraulics  
Does this line not include the hitch, snowplow and v-box spreader?

**Line 2 Front 10' snow plow**  
Is this line to include the plow hitch?

**Line 3 Front 11' snow plow**  
Is this line to include the plow hitch?

**Line 4 V-box spreader – This is self-explanatory**

**Answer: See updated Exhibit A Pricing Page**

---

## **19. EXCEPTIONS AND CLARIFICATIONS:**

**11. EXCEPTIONS AND CLARIFICATIONS:** The Solicitation contains the specifications that shall form the basis of a contractual agreement. Vendor shall clearly mark any exceptions, clarifications, or other proposed modifications in its bid. Exceptions to, clarifications of, or modifications of a requirement or term and condition of the Solicitation may result in bid disqualification.

**Question:** Please clarify #11” Exceptions and Clarifications” in regard to clearly marking of exceptions of a bid and the contract statement “consideration of clearly mark and exception clarifications” / Please explain why this remains to be in contract if it is verbally communicated in meeting that there are no exceptions to meeting specs in bid.

**Answer:** This is standard language contained in all solicitation terms and conditions and shall remain. See Instructions to Bidders Submitting Bids Section 5 regarding any pre-bid meeting verbal discussions:

**5. VERBAL COMMUNICATION:** Any verbal communication between the Vendor and any State personnel is not binding, including verbal communication at the mandatory pre-bid conference. Only information issued in writing and added to the Solicitation by an official written addendum by the Purchasing Division is binding.

## **20. 15A. RECIPROCAL PREFERENCE**

**15A. RECIPROCAL PREFERENCE:** The State of West Virginia applies a reciprocal preference to all solicitations for commodities and printing in accordance with W. Va. Code § 5A-3-37(b). In effect, non-resident vendors receiving a preference in their home states, will see that same preference granted to West Virginia resident vendors bidding against them in West Virginia. A request form to help facilitate the request can be found at:  
<http://www.state.wv.us/admin/purchase/vrc/Venpref.pdf>

**Question:** First Pages15A. Please clarify and give example of “Reciprocal Preference

**Question:** There was some discussion on the above items and vendor would like clarification?

**Answer:** See attached W. Va. Code §5A-3-37(b).

---

**21. 3.7.14.11 Cab, Cab Structure, Frame Rails and Crossmembers Warranty:** Cab, Cab Structure, Frame Rails and Crossmembers shall be warranty for corrosion for 5 years unlimited mileage 100% parts and labor.

**Question:** 3.7.14.11 Please expand/clarify on "corrosion" definition as in regard to surface rust vrs perforation of structural rust of (holes) on frame.

**Answer:** Inside out holes rusted in Cab /Major frame structural rust.

---

**22. 3.1.21.2** Shall have manufacturer's 12-volt negative ground system with manufacturer's radio interference suppression.

**Question:** 3.1.21.2 Please clarify further the radio interference suppression spec needed

**Answer:** Shall have no RFI Radio Frequency Interference if so needs to have RFI filter installed in signal path.

---

**23. 3.2.2.2** Top of corner post shall be dirt shedding. A 14-1/2" one-piece 7-gauge minimum stainless steel shall be break formed front to back at 5-1/2" and a downward slope remaining at 9".

**Question:** Will 15" one-piece 7-gauge minimum stainless steel shall be break formed front to back at 5-1/2" (without the downward slope remaining at 9")?

**Answer:** Remain as written

---

**24. 3.2.2.5** Reinforcement plate outside must be 16" tall minimum.

**3.2.2.6** Reinforcement plate bottom must be 8-3/4" long minimum.

**3.2.2.7** Reinforcement plate inside bottom height shall be 7-3/8" minimum to the floor.

**3.2.2.8** Reinforcement plate top shall be 4-1/4" minimum from outside to top of floor sheet.

**Question # 1:** Will rear full depth at rear corner post is 15" wide and straight with tarp friendly hardware be acceptable?

**Question # 2:** Are alternate reinforcement plates acceptable?

**Answer: Q-1 no, Remain as written.  
Q-2 Yes**

**25. 3.2.2.10** No front corner posts. Head sheet to have mirrored image of three (3) weld on full length horizontal side brace each side and shall be continuously welded to side brace, each side.

**Question:** Will one (1) formed outward “V” in head sheet be acceptable?

**Answer: No, leave as written**

---

**26. 3.2.2.11** One (1) Intermediate fully welded horizontal side brace, full-length both sides.

**Question:** Will one (1) formed outward “V” per side be acceptable?

**Answer: No, leave as written**

---

**27. 3.2.3.2** Bracing shall be full perimeter box type, minimum 6” top and bottom and 4” sides.

**Question:** Will 4” top and bottom and 4” sides be acceptable?

**Answer: No, leave as written**

---

**28. 3.2.3.17** Front corner of bottom rub rail must be capped with 7GA minimum stainless steel and be on an approximate 60-degree angle.

**Question:** Will formed 7GA with 7GA caps at a 45-degree angle be acceptable?

**Answer: No, leave as written**

---

**29. 3.2.4.12** Mounting height shall not exceed 8” from the top of chassis frame to dump body floor.

**Question:** Will 10” from the top of chassis frame to dump body floor be acceptable?

**Answer: No, leave as written**

**CHAPTER 5A. DEPARTMENT OF ADMINISTRATION.****ARTICLE 3. PURCHASING DIVISION.****§5A-3-37. Reciprocal preference; preference for resident vendors for certain contracts.**

(a) For purposes of this section, a vendor shall be deemed to be a resident of this state if such vendor:

(1) Is registered in accordance with §11-12-1 et seq. of this code to transact business within the State of West Virginia;

(2) Maintains its headquarters or principal place of business in the state;

(3) Has actually paid, and not just applied to pay, personal property taxes imposed by chapter 11 of this code on equipment used in the regular course of supplying services or commodities of the general type offered; and

(4) Has actually paid, and not just applied to pay, all required business taxes imposed by chapter 11 of this code.

(b) Except as provided in §5A-3-37(c) of this code, in any instance that a purchase of commodities or printing by the director or by a state spending unit is required under the provisions of this article to be made upon competitive bids, preference shall only be given to resident vendors of West Virginia against a nonresident vendor from any state that gives or requires a preference to bidders from that state. The amount of the preference shall be equal to the amount of the preference given or required by the state of the nonresident vendor for that particular supply.

(c)(1) In any instance that a purchase of motor vehicles or construction and maintenance equipment and machinery used in highway and other infrastructure projects by the director or by a state department is required under the provisions of this article to be made upon competitive bids, the successful bid shall be determined as provided in this subsection.

(2) For purposes of this subsection, a successful bid shall be determined and accepted as follows:

(A) From an individual resident vendor who has resided in West Virginia continuously for the four years immediately preceding the date on which the bid is submitted or from a partnership, association, corporation resident vendor, or from a corporation nonresident vendor which has an affiliate or subsidiary which employs a minimum of 100 state residents and which has maintained its headquarters or principal place of business within West Virginia continuously for four years immediately preceding the date on which the bid is submitted, if the vendor's bid does not exceed the lowest qualified bid from a nonresident vendor by more than two and one-half percent of the latter bid, and if the vendor has made written claim for the preference at the time the bid was submitted: Provided, That for purposes of this paragraph, any partnership, association, or corporation resident vendor of this state which does not meet the requirements of this paragraph solely because of



continuous four-year residence requirement, shall be considered to meet the requirement if at least 80 percent of the ownership interest of the resident vendor is held by another individual, partnership, association, or corporation resident vendor who otherwise meets the requirements of this paragraph, including the continuous four-year residency requirement: Provided, however, That the Purchasing Division shall promulgate rules relating to attribution of ownership among several resident vendors for purposes of determining the 80 percent ownership requirement; or

(B) From a resident vendor, if, for purposes of producing or distributing the motor vehicles or the construction and maintenance equipment and machinery used in highway and other infrastructure projects which are the subject of the vendor's bid and continuously over the entire term of the contract, on average at least 75 percent of the vendor's employees are residents of West Virginia who have resided in the state continuously for the two immediately preceding years, and the vendor's bid does not exceed the lowest qualified bid from a nonresident vendor by more than two and one-half percent of the latter bid, and if the vendor has certified the residency requirements of this paragraph and made written claim for the preference, at the time the bid was submitted; or

(C) From a nonresident vendor, which employs a minimum of 100 state residents or a nonresident vendor which has an affiliate or subsidiary which maintains its headquarters or principal place of business within West Virginia and which employs a minimum of 100 state residents, if, for purposes of producing or distributing the motor vehicles or the construction and maintenance equipment and machinery used in highway and other infrastructure projects which are the subject of the vendor's bid and continuously over the entire term of the contract, on average at least 75 percent of the vendor's employees or the vendor's affiliate's or subsidiary's employees are residents of West Virginia who have resided in the state continuously for the two immediately preceding years and the vendor's bid does not exceed the lowest qualified bid from a nonresident vendor by more than two and one-half percent of the latter bid, and if the vendor has certified the residency requirements of this paragraph and made written claim for the preference, at the time the bid was submitted; or

(D) From a vendor who meets either the requirements of both §5A-3-37(c)(2)(A) and §5A-3-37(c)(2)(B) of this code or §5A-3-37(c)(2)(A) and §5A-3-37(c)(2)(C) of this code, if the bid does not exceed the lowest qualified bid from a nonresident vendor by more than five percent of the latter bid, and if the vendor has certified the residency requirements above and made written claim for the preference at the time the bid was submitted; or

(E) From an individual resident vendor who is a veteran of the United States armed forces, the reserves or the National Guard and has resided in West Virginia continuously for the four years immediately preceding the date on which the bid is submitted, if the vendor's bid does not exceed the lowest qualified bid from a nonresident vendor by more than three and one-half percent of the latter bid, and if the vendor has made written claim for the preference at the time the bid was submitted; or

(F) From a resident vendor who is a veteran of the United States armed forces, the reserves or the National Guard, if, for purposes of producing or distributing motor vehicles or construction and maintenance equipment and machinery used in highway and other infrastructure projects which are the subject of the vendor's bid and continuously over the entire term of the contract, on average at least 75 percent of the vendor's employees are residents of West Virginia who have resided in the

state continuously for the two immediately preceding years and the vendor's bid does not exceed the lowest qualified bid from a nonresident vendor by more than three and one-half percent of the latter bid, and if the vendor has certified the residency requirements of this paragraph and made written claim for the preference, at the time the bid was submitted; or

(G) Notwithstanding any provisions of §5A-3-37(c)(2)(A), §5A-3-37(c)(2)(B), §5A-3-37(c)(2)(C), §5A-3-37(c)(2)(D), §5A-3-37(c)(2)(E), or §5A-3-37(c)(2)(F) of this code to the contrary, if any nonresident vendor that is bidding on the purchase of motor vehicles or construction and maintenance equipment and machinery used in highway and other infrastructure projects by the director or by a state department is also certified as a small-, women-, or minority-owned business pursuant to §5A-3-59, the nonresident vendor shall be provided the same preference made available to any resident vendor under the provisions of this subdivision.

(3) If any of the requirements or provisions set forth in this section jeopardize the receipt of federal funds, then the requirement or provisions are void and of no force and effect for that specific project.

(4) The Purchasing Division shall promulgate any rules necessary to: (A) Determine that vendors have met the residence requirements described in this section; (B) establish the procedure for vendors to certify the residency requirements at the time of submitting their bids; (C) establish a procedure to audit bids which make a claim for preference permitted by this section and to reject noncomplying bids; and (D) otherwise accomplish the objectives of this subsection.

(d) If the Purchasing Division determines under any audit procedure that a vendor who received a preference under this section fails to continue to meet the requirements for the preference at any time during the term of the contract for which the preference was received the Purchasing Division may: (1) Reject the vendor's bid; or (2) assess a penalty against the vendor of not more than five percent of the vendor's bid on the contract.

(e) Political subdivisions of the state including county boards of education may grant the same preferences to any vendor of this state who has made a written claim for the preference at the time a bid is submitted, but for the purposes of this subsection, in determining the lowest bid, any political subdivision shall exclude from the bid the amount of business occupation taxes which must be paid by a resident vendor to any municipality within the county comprising or located within the political subdivision as a result of being awarded the contract which is the object of the bid; in the case of a bid received by a municipality, the municipality shall exclude only the business and occupation taxes as will be paid to the municipality: Provided, That prior to soliciting any competitive bids, any political subdivision may, by majority vote of all its members in a public meeting where all the votes are recorded, elect not to exclude from the bid the amount of business and occupation taxes as provided in this subsection.

**ADDENDUM ACKNOWLEDGEMENT FORM**  
**SOLICITATION NO.: DOT1900000128**

**Instructions:** Please acknowledge receipt of all addenda issued with this solicitation by completing this addendum acknowledgment form. Check the box next to each addendum received and sign below. Failure to acknowledge addenda may result in bid disqualification.

**Acknowledgment:** I hereby acknowledge receipt of the following addenda and have made the necessary revisions to my proposal, plans and/or specification, etc.

**Addendum Numbers Received:**

(Check the box next to each addendum received)

- |  |  |
|--|--|
| <input checked="" type="checkbox"/> Addendum No. 1 | <input type="checkbox"/> Addendum No. 6  |
| <input checked="" type="checkbox"/> Addendum No. 2 | <input type="checkbox"/> Addendum No. 7  |
| <input type="checkbox"/> Addendum No. 3            | <input type="checkbox"/> Addendum No. 8  |
| <input type="checkbox"/> Addendum No. 4            | <input type="checkbox"/> Addendum No. 9  |
| <input type="checkbox"/> Addendum No. 5            | <input type="checkbox"/> Addendum No. 10 |

I understand that failure to confirm the receipt of addenda may be cause for rejection of this bid. I further understand that any verbal representation made or assumed to be made during any oral discussion held between Vendor's representatives and any state personnel is not binding. Only the information issued in writing and added to the specifications by an official addendum is binding.

Worldwide Equipment

Company



Authorized Signature

7/16/19

Date

**NOTE:** This addendum acknowledgment should be submitted with the bid to expedite document processing.

Revised 6/8/2012



Purchasing Division  
 2019 Washington Street East  
 Post Office Box 50130  
 Charleston, WV 25305-0130

State of West Virginia  
 Request for Quotation  
 19 – Highways

Proc Folder: 589305

Doc Description: ADDENDUM 2 41K GVWR SINGLE AXLE DUMP TRUCK (7019EC16)

Proc Type: Central Master Agreement

| Date Issued | Solicitation Closes    | Solicitation No         | Version |
|-------------|------------------------|-------------------------|---------|
| 2019-07-09  | 2019-07-17<br>13:30:00 | CRFQ 0803 DOT1900000128 | 3       |

**BID RECEIVING LOCATION**

BID CLERK  
 DEPARTMENT OF ADMINISTRATION  
 PURCHASING DIVISION  
 2019 WASHINGTON ST E  
 CHARLESTON WV 25305  
 US

**VENDOR**

Vendor Name, Address and Telephone Number:

Worldwide Equipment  
 5650 US Route 60 East  
 Huntington, WV 25705  
 304-345-2490

**FOR INFORMATION CONTACT THE BUYER**

Crystal G Hustead  
 (304) 558-2402  
 crystal.g.hustead@wv.gov

Signature X

FEIN # 45-1024981

DATE 7/16/19

All offers subject to all terms and conditions contained in this solicitation

**ADDITIONAL INFORMATION:**

THE WEST VIRGINIA PURCHASING DIVISION IS SOLICITING BIDS ON BEHALF OF THE WEST VIRGINIA DIVISION OF HIGHWAYS, DEPARTMENT OF TRANSPORTATION, TO ESTABLISH AN OPEN-END CONTRACT FOR A 41,000 GVWR SINGLE AXLE DUMP TRUCK WITH SNOW PLOW AND V-BOX SPREADER PER THE ATTACHED DOCUMENTS.

| INVOICE TO  |  | SHIP TO   |  |
|---|--|---|--|
| DIVISION OF HIGHWAYS<br>EQUIPMENT DIVISION RT 33<br>83 BRUSHY ROAD CROSSING, PO BOX 610<br>BUCKHANNON WV26201<br>US |  | DIVISION OF HIGHWAYS<br>EQUIPMENT DIVISION<br>83 BRUSHY FORK RD CROSSING<br>BUCKHANNON WV 26201<br>US |  |

| Line | Comm Ln Desc          | Qty       | Unit Issue | Unit Price   | Total Price     |
|------|-----------------------|-----------|------------|--------------|-----------------|
| 1    | CAB CHASSIS/DUMP BODY | 120.00000 | EA         | \$142,675.04 | \$17,121,004.80 |

| Comm Code | Manufacturer  | Specification                           | Model #   |
|-----------|---------------|---|-----------|
| 25101601  | International | Single Axel Dumo Meeting Specifications | HV507 SFA |

**Extended Description :**

CAB CHASSIS/DUMP BODY WITH HYD. AND SPREADER CONTROL SYSTEM

| INVOICE TO  |  | SHIP TO   |  |
|---|--|---|--|
| DIVISION OF HIGHWAYS<br>EQUIPMENT DIVISION RT 33<br>83 BRUSHY ROAD CROSSING, PO BOX 610<br>BUCKHANNON WV26201<br>US |  | DIVISION OF HIGHWAYS<br>EQUIPMENT DIVISION<br>83 BRUSHY FORK RD CROSSING<br>BUCKHANNON WV 26201<br>US |  |

| Line | Comm Ln Desc          | Qty       | Unit Issue | Unit Price  | Total Price    |
|------|-----------------------|-----------|------------|-------------|----------------|
| 2    | FRONT 10FT. SNOW PLOW | 120.00000 | EA         | \$11,682.00 | \$1,401,840.00 |

| Comm Code | Manufacturer | Specification   | Model #  |
|-----------|--------------|-----------------|----------|
| 25101601  | Viking Cives | Per WV DOH Spec | 10' Plow |

**Extended Description :**

FRONT 10FT. SNOW PLOW WITH PLOW MOUNT

| INVOICE TO  |  | SHIP TO   |  |
|---|--|---|--|
| DIVISION OF HIGHWAYS<br>EQUIPMENT DIVISION RT 33<br>83 BRUSHY ROAD CROSSING, PO BOX 610<br>BUCKHANNON WV26201<br>US |  | DIVISION OF HIGHWAYS<br>EQUIPMENT DIVISION<br>83 BRUSHY FORK RD CROSSING<br>BUCKHANNON WV 26201<br>US |  |

| Line | Comm Ln Desc          | Qty       | Unit Issue | Unit Price  | Total Price    |
|------|-----------------------|-----------|------------|-------------|----------------|
| 3    | FRONT 11FT. SNOW PLOW | 120.00000 | EA         | \$12,632.00 | \$1,515,840.00 |

| Comm Code | Manufacturer | Specification   | Model #       |
|-----------|--------------|-----------------|---------------|
| 25101601  | Viking Cives | Per WV DOH Spec | 11' Snow Plow |

Extended Description :  
FRONT 11FT. SNOW PLOW WITH PLOW MOUNT

| INVOICE TO  | SHIP TO   |
|---|---|
| DIVISION OF HIGHWAYS<br>EQUIPMENT DIVISION RT 33<br>83 BRUSHY ROAD CROSSING, PO BOX 610<br>BUCKHANNON WV26201<br>US | DIVISION OF HIGHWAYS<br>EQUIPMENT DIVISION<br>83 BRUSHY FORK RD CROSSING<br>BUCKHANNON WV 26201<br>US |

| Line | Comm Ln Desc   | Qty       | Unit Issue | Unit Price  | Total Price    |
|------|----------------|-----------|------------|-------------|----------------|
| 4    | V-BOX SPREADER | 120.00000 | EA         | \$19,955.00 | \$2,394,600.00 |

| Comm Code | Manufacturer | Specification   | Model #        |
|-----------|--------------|-----------------|----------------|
| 25101601  | Viking Cives | Per WV DOH Spec | V-Box Spreader |

Extended Description :  
V-BOX SPREADER

**SCHEDULE OF EVENTS**

| Line | Event                     | Event Date |
|------|---------------------------|------------|
| 1    | MANDATORY PRE-BID MEETING | 2019-06-25 |
| 2    | VENDOR QUESTION DEADLINE  | 2019-06-28 |

|                      |                                |   |                       |
|----------------------|--------------------------------|---|-----------------------|
| <b>DOT1900000128</b> | <b>Document Phase</b><br>Final | <b>Document Description</b><br>ADDENDUM 2 41K GVWR SINGLE AXLE<br>DUMP TRUCK (7019EC16) | <b>Page 4</b><br>of 4 |
|----------------------|--------------------------------|---|-----------------------|

**ADDITIONAL TERMS AND CONDITIONS**

See attached document(s) for additional Terms and Conditions