

Exhibit A Pricing Page  
Baler for Recycling Program

ITEM	DESCRIPTION	Each	UNIT PRICE	Extended Total
1	<b>Closed Door Manual Tie Full Eject Horizontal Baler</b>	1	\$130,825.00	\$130,825.00
	International Baler Corp. Model Titan 60-XHP and CY-48178 Conve			
2	Optional New Oil Cooler for Baler	1	3,000.00	
				\$130,825.00
	<b>Vendor Name: BE EQUIPMENT, INC.</b>			
	<b>Address: 17775 Wentz Road, PO Box 139, Quakertown, PA 18951</b>			
	<b>Phone: (215) 536-0700 x5500</b>	<b>Fax: (215) 526-2999</b>		
	<b>Authorized Signature:</b> 	<b>Date: 02/28/2020</b>		
Failure to use this bid form may result in disqualification.				

RECEIVED  
2020 MAR -3 AM 9:32  
WV PURCHASING  
DIVISION

**DESIGNATED CONTACT:** Vendor appoints the individual identified in this Section as the Contract Administrator and the initial point of contact for matters relating to this Contract.

Jonathan Mann, National Sales Manager *JM*

(Name, Title)

Jonathan Mann, National Sales Manager

(Printed Name and Title)

1775 Wentz Road, PO Box 139, Quakertown, PA 18951

(Address)

(215) 536-0700 x5300 / (215) 536-2999

(Phone Number) / (Fax Number)

jonathan.mann@beequipment.com and bids@beequipment.com

(email address)

**CERTIFICATION AND SIGNATURE:** By signing below, or submitting documentation through wvOASIS, I certify that I have reviewed this Solicitation in its entirety; that I understand the requirements, terms and conditions, and other information contained herein; that this bid, offer or proposal constitutes an offer to the State that cannot be unilaterally withdrawn; that the product or service proposed meets the mandatory requirements contained in the Solicitation for that product or service, unless otherwise stated herein; that the Vendor accepts the terms and conditions contained in the Solicitation, unless otherwise stated herein; that I am submitting this bid, offer or proposal for review and consideration; that I am authorized by the vendor to execute and submit this bid, offer, or proposal, or any documents related thereto on vendor's behalf; that I am authorized to bind the vendor in a contractual relationship; and that to the best of my knowledge, the vendor has properly registered with any State agency that may require registration.

BE EQUIPMENT, INC.

(Company)

Scott H. Davis, President

(Authorized Signature) (Representative Name, Title)

Scott H. Davis, President

(Printed Name and Title of Authorized Representative)

02/28/2020

(Date)

(215) 536-0700 / (215) 536-2999

(Phone Number) (Fax Number)

# SOLICITATION NUMBER: CRFQ ADJ2000000013

## Addendum Number: 1

The purpose of this addendum is to modify the solicitation identified as CRFQ ADJ2000000013 ("Solicitation") to reflect the change(s) identified and described below.

### Applicable Addendum Category:

- Modify bid opening date and time
- Modify specifications of product or service being sought
- Attachment of vendor questions and responses
- Attachment of pre-bid sign-in sheet
- Correction of error
- Other-

### Additional Documentation:

1. Responses to Vendor Questions
2. The bid opening remains on 02/28/2020 at 1:30 pm.

### Terms and Conditions:

1. All provisions of the Solicitation and other addenda not modified herein shall remain in full force and effect.
2. Vendor should acknowledge receipt of all addenda issued for this Solicitation by completing an Addendum Acknowledgment, a copy of which is included herewith. Failure to acknowledge addenda may result in bid disqualification. The addendum acknowledgement should be submitted with the bid to expedite document processing.

**ADDENDUM ACKNOWLEDGEMENT FORM**  
**SOLICITATION NO.: CRFQ ADJ200000013**

**Instructions:** Please acknowledge receipt of all addenda issued with this solicitation by completing this addendum acknowledgment form. Check the box next to each addendum received and sign below. Failure to acknowledge addenda may result in bid disqualification.

**Acknowledgment:** I hereby acknowledge receipt of the following addenda and have made the necessary revisions to my proposal, plans and/or specification, etc.

**Addendum Numbers Received:**

(Check the box next to each addendum received)

- |  |  |
|--|--|
| <input checked="" type="checkbox"/> Addendum No. 1 | <input type="checkbox"/> Addendum No. 6  |
| <input type="checkbox"/> Addendum No. 2            | <input type="checkbox"/> Addendum No. 7  |
| <input type="checkbox"/> Addendum No. 3            | <input type="checkbox"/> Addendum No. 8  |
| <input type="checkbox"/> Addendum No. 4            | <input type="checkbox"/> Addendum No. 9  |
| <input type="checkbox"/> Addendum No. 5            | <input type="checkbox"/> Addendum No. 10 |

I understand that failure to confirm the receipt of addenda may be cause for rejection of this bid. I further understand that that any verbal representation made or assumed to be made during any oral discussion held between Vendor's representatives and any state personnel is not binding. Only the information issued in writing and added to the specifications by an official addendum is binding.

BE EQUIPMENT, INC.

Company



Authorized Signature

02/28/2020

Date

NOTE: This addendum acknowledgment should be submitted with the bid to expedite document processing.

**SOLICITATION NUMBER: CRFQ ADJ2000000013**  
**Addendum Number: 2**

The purpose of this addendum is to modify the solicitation identified as CRFQ ADJ2000000013 ("Solicitation") to reflect the change(s) identified and described below.

**Applicable Addendum Category:**

- Modify bid opening date and time
- Modify specifications of product or service being sought
- Attachment of vendor questions and responses
- Attachment of pre-bid sign-in sheet
- Correction of error
- Other-

**Additional Documentation:**

1. Responses to Vendor Questions
2. The bid opening changes to 03/04/2020 at 1:30 pm.

**Terms and Conditions:**

1. All provisions of the Solicitation and other addenda not modified herein shall remain in full force and effect.
2. Vendor should acknowledge receipt of all addenda issued for this Solicitation by completing an Addendum Acknowledgment, a copy of which is included herewith. Failure to acknowledge addenda may result in bid disqualification. The addendum acknowledgement should be submitted with the bid to expedite document processing.

**ADDENDUM ACKNOWLEDGEMENT FORM**  
**SOLICITATION NO.: CRFO ADJ2000000013**

**Instructions:** Please acknowledge receipt of all addenda issued with this solicitation by completing this addendum acknowledgment form. Check the box next to each addendum received and sign below. Failure to acknowledge addenda may result in bid disqualification.

**Acknowledgment:** I hereby acknowledge receipt of the following addenda and have made the necessary revisions to my proposal, plans and/or specification, etc.

**Addendum Numbers Received:**

(Check the box next to each addendum received)

- |  |  |
|--|--|
| <input type="checkbox"/> Addendum No. 1            | <input type="checkbox"/> Addendum No. 6  |
| <input checked="" type="checkbox"/> Addendum No. 2 | <input type="checkbox"/> Addendum No. 7  |
| <input type="checkbox"/> Addendum No. 3            | <input type="checkbox"/> Addendum No. 8  |
| <input type="checkbox"/> Addendum No. 4            | <input type="checkbox"/> Addendum No. 9  |
| <input type="checkbox"/> Addendum No. 5            | <input type="checkbox"/> Addendum No. 10 |

I understand that failure to confirm the receipt of addenda may be cause for rejection of this bid. I further understand that that any verbal representation made or assumed to be made during any oral discussion held between Vendor's representatives and any state personnel is not binding. Only the information issued in writing and added to the specifications by an official addendum is binding.

BE EQUIPMENT, INC.

Company

Authorized Signature

02/28/2020

Date

NOTE: This addendum acknowledgement should be submitted with the bid to expedite document processing.

STATE OF WEST VIRGINIA  
Purchasing Division

# PURCHASING AFFIDAVIT

**CONSTRUCTION CONTRACTS:** Under W. Va. Code § 5-22-1(i), the contracting public entity shall not award a construction contract to any bidder that is known to be in default on any monetary obligation owed to the state or a political subdivision of the state, including, but not limited to, obligations related to payroll taxes, property taxes, sales and use taxes, fire service fees, or other fines or fees.

**ALL OTHER CONTRACTS:** Under W. Va. Code §5A-3-10a, no contract or renewal of any contract may be awarded by the state or any of its political subdivisions to any vendor or prospective vendor when the vendor or prospective vendor or a related party to the vendor or prospective vendor is a debtor and: (1) the debt owed is an amount greater than one thousand dollars in the aggregate; or (2) the debtor is in employer default.

**EXCEPTION:** The prohibition listed above does not apply where a vendor has contested any tax administered pursuant to chapter eleven of the W. Va. Code, workers' compensation premium, permit fee or environmental fee or assessment and the matter has not become final or where the vendor has entered into a payment plan or agreement and the vendor is not in default of any of the provisions of such plan or agreement.

**DEFINITIONS:**

**"Debt"** means any assessment, premium, penalty, fine, tax or other amount of money owed to the state or any of its political subdivisions because of a judgment, fine, permit violation, license assessment, defaulted workers' compensation premium, penalty or other assessment presently delinquent or due and required to be paid to the state or any of its political subdivisions, including any interest or additional penalties accrued thereon.

**"Employer default"** means having an outstanding balance or liability to the old fund or to the uninsured employers' fund or being in policy default, as defined in W. Va. Code § 23-2c-2, failure to maintain mandatory workers' compensation coverage, or failure to fully meet its obligations as a workers' compensation self-insured employer. An employer is not in employer default if it has entered into a repayment agreement with the Insurance Commissioner and remains in compliance with the obligations under the repayment agreement.

**"Related party"** means a party, whether an individual, corporation, partnership, association, limited liability company or any other form or business association or other entity whatsoever, related to any vendor by blood, marriage, ownership or contract through which the party has a relationship of ownership or other interest with the vendor so that the party will actually or by effect receive or control a portion of the benefit, profit or other consideration from performance of a vendor contract with the party receiving an amount that meets or exceeds five percent of the total contract amount.

**AFFIRMATION:** By signing this form, the vendor's authorized signer affirms and acknowledges under penalty of law for false swearing (W. Va. Code §61-5-3) that: (1) for construction contracts, the vendor is not in default on any monetary obligation owed to the state or a political subdivision of the state, and (2) for all other contracts, that neither vendor nor any related party owe a debt as defined above and that neither vendor nor any related party are in employer default as defined above, unless the debt or employer default is permitted under the exception above.

**WITNESS THE FOLLOWING SIGNATURE:**

Vendor's Name: BE EQUIPMENT, INC.

Authorized Signature: *[Signature]* Date: 02/28/2020

State of Pennsylvania

County of Bucks, to-wit:

Taken, subscribed, and sworn to before me this 28<sup>th</sup> day of February, 2020

My Commission expires Nov. 14, 2020, 20  

**AFFIX SEAL HERE**  
Commonwealth of Pennsylvania - Notary Seal  
DAWN M GILLEY - Notary Public  
Bucks County  
My Commission Expires Nov 14, 2020  
Commission Number 1232216

NOTARY PUBLIC *[Signature]*  
Purchasing Affidavit (Revised 07/07/2017)

State of West Virginia  
**VENDOR PREFERENCE CERTIFICATE**

Certification and application is hereby made for Preference in accordance with **West Virginia Code**, §5A-3-37. (Does not apply to construction contracts). **West Virginia Code**, §5A-3-37, provides an opportunity for qualifying vendors to request (at the time of bid) preference for their residency status. Such preference is an evaluation method only and will be applied only to the cost bid in accordance with the **West Virginia Code**. This certificate for application is to be used to request such preference. The Purchasing Division will make the determination of the Vendor Preference, if applicable.

**1. Application is made for 2.5% vendor preference for the reason checked:**

Bidder is an individual resident vendor and has resided continuously in West Virginia, or bidder is a partnership, association or corporation resident vendor and has maintained its headquarters or principal place of business continuously in West Virginia, for four (4) years immediately preceding the date of this certification; **or**,

Bidder is a resident vendor partnership, association, or corporation with at least eighty percent of ownership interest of bidder held by another entity that meets the applicable four year residency requirement; **or**,

Bidder is a nonresident vendor which has an affiliate or subsidiary which employs a minimum of one hundred state residents and which has maintained its headquarters or principal place of business within West Virginia continuously for the four (4) years immediately preceding the date of this certification; **or**,

**2. Application is made for 2.5% vendor preference for the reason checked:**

Bidder is a resident vendor who certifies that, during the life of the contract, on average at least 75% of the employees working on the project being bid are residents of West Virginia who have resided in the state continuously for the two years immediately preceding submission of this bid; **or**,

**3. Application is made for 2.5% vendor preference for the reason checked:**

Bidder is a nonresident vendor that employs a minimum of one hundred state residents, or a nonresident vendor which has an affiliate or subsidiary which maintains its headquarters or principal place of business within West Virginia and employs a minimum of one hundred state residents, and for purposes of producing or distributing the commodities or completing the project which is the subject of the bidder's bid and continuously over the entire term of the project, on average at least seventy-five percent of the bidder's employees or the bidder's affiliate's or subsidiary's employees are residents of West Virginia who have resided in the state continuously for the two immediately preceding years and the vendor's bid; **or**,

**4. Application is made for 5% vendor preference for the reason checked:**

Bidder meets either the requirement of both subdivisions (1) and (2) or subdivision (1) and (3) as stated above; **or**,

**5. Application is made for 3.5% vendor preference who is a veteran for the reason checked:**

Bidder is an individual resident vendor who is a veteran of the United States armed forces, the reserves or the National Guard and has resided in West Virginia continuously for the four years immediately preceding the date on which the bid is submitted; **or**,

**6. Application is made for 3.5% vendor preference who is a veteran for the reason checked:**

Bidder is a resident vendor who is a veteran of the United States armed forces, the reserves or the National Guard, if, for purposes of producing or distributing the commodities or completing the project which is the subject of the vendor's bid and continuously over the entire term of the project, on average at least seventy-five percent of the vendor's employees are residents of West Virginia who have resided in the state continuously for the two immediately preceding years.

**7. Application is made for preference as a non-resident small, women- and minority-owned business, in accordance with West Virginia Code §5A-3-59 and West Virginia Code of State Rules.**

Bidder has been or expects to be approved prior to contract award by the Purchasing Division as a certified small, women- and minority-owned business.

**8. Application is made for reciprocal preference.**

Bidder is a West Virginia resident and is requesting reciprocal preference to the extent that it applies.

Bidder understands if the Secretary of Revenue determines that a Bidder receiving preference has failed to continue to meet the requirements for such preference, the Secretary may order the Director of Purchasing to: (a) rescind the contract or purchase order; or (b) assess a penalty against such Bidder in an amount not to exceed 5% of the bid amount and that such penalty will be paid to the contracting agency or deducted from any unpaid balance on the contract or purchase order.

By submission of this certificate, Bidder agrees to disclose any reasonably requested information to the Purchasing Division and authorizes the Department of Revenue to disclose to the Director of Purchasing appropriate information verifying that Bidder has paid the required business taxes, provided that such information does not contain the amounts of taxes paid nor any other information deemed by the Tax Commissioner to be confidential.

**Bidder hereby certifies that this certificate is true and accurate in all respects; and that if a contract is issued to Bidder and if anything contained within this certificate changes during the term of the contract, Bidder will notify the Purchasing Division in writing immediately.**

Bidder: BE EQUIPMENT, INC.

Signed: 

Date: 02/28/2020

Title: President

\*Check any combination of preference consideration(s) indicated above, which you are entitled to receive.



# ***BE Equipment, Inc.***



*PA: (215) 536-0700 x5300 • NJ: (732) 846-9920 • MD: (410) 661-1333*

*Fax: (215) 536-2999 • Cell: (267) 549-2330*

*Em: [jonathan.mann@beequipment.com](mailto:jonathan.mann@beequipment.com)*

*[www.beequipment.com](http://www.beequipment.com)*

***Proposal for  
CRFQ 0603 ADJ2000000013  
for a Closed Door Manual Tie  
Full Eject Horizontal Baler for  
Adjutant Generals Office  
Point Pleasant, WV 25550***

***Presented to:***

***Mr. John W. Estep  
Buyer  
STATE OF WEST VIRGINIA  
Bid Clerk  
Department of Administration,  
Purchasing Division  
2019 Washington Street East  
Charleston, WV 25305-2214***

***Presented By:***

***Jonathan Mann  
February 28, 2020***



**Proposal No. 20-02-45**

February 28, 2020

Ph: (304) 558-7839

Fx: (304) 558-3970

Fx: (304) 558-4115

Em: [john.w.estep@wv.gov](mailto:john.w.estep@wv.gov)

RECYCLING AND SOLID WASTE HANDLING SYSTEMS  
1775 Wentz Road, P.O. Box 139, Quakertown, PA 18951  
PA: (215) 536-0700 MD: (410) 661-1333  
NJ: (732) 846-9920 FAX: (215) 536-2999  
www.beequipment.com • sales@beequipment.com

Mr. John W. Estep  
Buyer  
**STATE OF WEST VIRGINIA**  
Bid Clerk  
Department of Administration,  
Purchasing Division  
2019 Washington Street East  
Charleston, WV 25305-2214

**Re: CRFQ 0603 ADJ2000000013 for a Closed Door  
Manual Tie Full Eject Horizontal Baler for  
Adjutant Generals Office, Point Pleasant  
Armory-Tire Rebuild Shop, 4194 Ohio River  
Road, Point Pleasant, WV 25550**

Dear Mr. Estep:

Thank you for the opportunity to Quote your Baler Project. Based on your bid documents and specifications, we are pleased to propose the following Items for your consideration:

*(Meets or Exceeds Specifications)*

**ITEM ONE:**

**One New INTERNATIONAL BALER CORP. MODEL TITAN 60-XHP AUTOMATIC,  
HORIZONTAL, MULTI-MATERIALS, FULL-EJECT, CLOSED-DOOR, MANUAL-TIE BALER**

Dimensions:	
Length:	275 <sup>7</sup> / <sub>8</sub> " with Baler Door Open
Overall Width:	86"
Height:	101 <sup>1</sup> / <sub>2</sub> " (Top of Hopper)
Bale Size:	60" W x 30" H x 48" L
System Operating Pressure:	4,000 psi (Maximum)
Total Platen Force:	201,062 Pounds
Platen Pressure:	116 psi (Normal)

Continued,



Cycle Time: 33 Seconds (Full Stroke); 19 Seconds (Short Stroke) (No Load)  
Bale Weight: Up to 1,400 Pounds (OCC)  
Hopper Opening: 56" W x 40" L  
Main Motor: 30 HP, **230 Volt, 3 Phase**, 60 Hz, TEFC, High Efficiency (Standard)  
Main Cylinder: 8" Bore, 6" Rod, 90" Stroke  
Oil Reservoir: 165 Gallons (**Oil Included with Installation**)  
**Included Option: Conveyor Style Hopper**

Performance rates, bale weights, and bale densities are subject to moisture content, material pre-bale densities, feed rates, and other variables in baling.

Please refer to the enclosed specifications sheet and drawing for complete dimensional/performance specifications

**ITEM TWO:**

**One New INTERNATIONAL BALER CORP. MODEL CY-48178 ABOVE GROUND, INCLINED, CLEATED, SLIDER BED, BALER FEED CONVEYOR**

Conveyor Size: 48" W x 178" L  
Conveyor Motor: 3 HP, **230 Volt, 3 Phase**, 60 Hz, TEFC, High Efficiency  
Belt Type: Heavy-Duty, 250 PVC  
Feed Hopper: Flared to Accept Waste  
**Includes: Baler Hopper to Match Conveyor and Conveyor Controls**

Please refer to the enclosed specifications sheet and drawing for more dimensional/performance specifications.

**TOTAL PACKAGE PRICE: DELIVERED AND INSTALLED ..... \$130,825.00**

**SHIPMENT:** Approximately 12 to 14 Weeks from Receipt of Order, Deposit, and Approved Drawings, Based upon Current Manufacturing Schedule. *Time for Shipment should be Confirmed at the Time of Order Placement.*

**ADDITIONAL ITEM:**

**ITEM A:**

**One New OIL COOLER for the Above Proposed Baler**

**ITEM A PRICE: DELIVERED AND INSTALLED .....ADD \$ 3,000.00**

Continued,



**Warranty: 1 Year or 2,000 Hours, whichever Comes First on Labor; 2 Years or 4,000 Hours, whichever Comes First, on Parts; and 3 Years or 6,000 Hours, whichever Comes First, on Structure**

**The Above Prices Include the Following:**

1. All Freight to Site, Including Any Freight Permits
2. All Rigging and Heavy Lifting Equipment
3. All Rigging and Assembly Labor
4. Hydraulic Oil for Baler Reservoir
5. Start-up Adjustments and Training

**Work by Others:**

1. All Main Power and Control Wiring except for Pre-wired Control Panels which are a Part of the Machines offered in this Proposal. *Customer to Provide Suitable Three Phase Electric Service to a Safety Disconnect Switch in Close Proximity to the Baler Control Panel Location. **Customer's Electrician should be On Site at the Time of Baler Installation to make the Final Connection from the Disconnect Switch to the Baler Control Panel.** Our Installation Personnel will then provide Start-Up Adjustment and Training. **Additional Charges will be incurred if a Return Trip is Required to provide Start-Up Adjustment and Training.***
2. Any Required Building Modifications, Licenses, and/or Permits, **Including Suitable Level Concrete Pads**

**NOTE:** The above Prices Do Not Include Baling Wire; ***we can Provide this to you at Additional Cost.*** You will be **Required** to have Enough Wire on Site at Time of Installation for the Technician to Perform the Start-up of the Baler.

**TERMS:** Full Balance Due at Time of Installation and Acceptance  
OR  
APPROVED LEASE PURCHASE

*Major Credit Cards are Accepted (subject to 3% credit card company processing fee)*

**NOTE: Terms are Subject to Credit Approval**

The above prices do NOT include state or local taxes, if applicable

***Ask your Tax Accountant about Possible Tax Benefits for the Purchase of Recycling Equipment in 2020.***

If this proposal is in conformity with your understanding, please sign this proposal and return to our office immediately, so we may begin processing your order.

Continued,

Page 4 of 4  
Mr. John W. Estep  
STATE OF WEST VIRGINIA

**Proposal No. 20-02-45**  
February 28, 2020



Should you have any questions, please do not hesitate to call me in the office at (215) 536-0700, Ext. 5300, or (267) 680-9037, on my cell phone at (267) 549-2330, or email me at [jonathan.mann@beequipment.com](mailto:jonathan.mann@beequipment.com).

Thank you.

Sincerely,

A handwritten signature in blue ink that reads 'Jonathan Mann' followed by a stylized initial 'JM'.

Jonathan Mann  
National Sales Manager  
BE EQUIPMENT, INC.

JM/LM

Enclosures:

1. BE Equipment, Inc. Brochure, Revised 12-17
2. BE Equipment, Inc. 2015 Service Brochure
3. International Baler Corp. Titan Series Horizontal Balers 2012 Brochure
4. International Baler Corp. Model Titan-60-XHP Closed Door Horizontal Series Specifications Sheet
5. International Baler Corp. CY-48178 Above Ground Conveyor Specifications Sheet, 8/8/2014
6. International Baler Corp. Titan-60-XHP (with CY-48178 Conveyor) GA Drawing, Dated 4-4-12
7. International Baler Corp. Limited Product Warranty February 23, 2018 (**Standard Warranty**)
8. International Baler Corp. Terms & Conditions of Sale, Issued January 1, 2016
9. BE Equipment, Inc. Standard Terms and Conditions January 3, 2014

PROPOSAL ACCEPTED BY: \_\_\_\_\_

With ADDITIONAL ITEM #: \_\_\_\_\_ DATE: \_\_\_\_\_

**Clerical errors are subject to correction.**



**Proposal No. 20-02-45**

February 28, 2020

Ph: (304) 558-7839

Fx: (304) 558-3970

Fx: (304) 558-4115

Em: [john.w.estep@wv.gov](mailto:john.w.estep@wv.gov)

RECYCLING AND SOLID WASTE HANDLING SYSTEMS  
1775 Wentz Road, P.O. Box 139, Quakertown, PA 18951  
PA: (215) 536-0700 MD: (410) 661-1333  
NJ: (732) 846-9920 FAX: (215) 536-2999  
[www.beequipment.com](http://www.beequipment.com) • [sales@beequipment.com](mailto:sales@beequipment.com)



Mr. John W. Estep  
Buyer  
**STATE OF WEST VIRGINIA**  
Bid Clerk  
Department of Administration,  
Purchasing Division  
2019 Washington Street East  
Charleston, WV 25305-2214

**Re: CRFQ 0603 ADJ2000000013 for a Closed Door  
Manual Tie Full Eject Horizontal Baler for  
Adjutant Generals Office, Point Pleasant  
Armory-Tire Rebuild Shop, 4194 Ohio River  
Road, Point Pleasant, WV 25550**

Dear Mr. Estep:

Thank you for the opportunity to Quote your Baler Project. Based on your bid documents and specifications, we are pleased to propose the following Items for your consideration:

*(Meets or Exceeds Specifications)*

**ITEM ONE:**

**One New INTERNATIONAL BALER CORP. MODEL TITAN 60-XHP AUTOMATIC,  
HORIZONTAL, MULTI-MATERIALS, FULL-EJECT, CLOSED-DOOR, MANUAL-TIE BALER**

Dimensions:	
Length:	275 $\frac{1}{8}$ " with Baler Door Open
Overall Width:	86"
Height:	101 $\frac{1}{2}$ " (Top of Hopper)
Bale Size:	60" W x 30" H x 48" L
System Operating Pressure:	4,000 psi (Maximum)
Total Platen Force:	201,062 Pounds
Platen Pressure:	116 psi (Normal)

Continued,



Cycle Time: 33 Seconds (Full Stroke); 19 Seconds (Short Stroke) (No Load)  
Bale Weight: Up to 1,400 Pounds (OCC)  
Hopper Opening: 56" W x 40" L  
Main Motor: 30 HP, **230 Volt, 3 Phase**, 60 Hz, TEFC, High Efficiency (Standard)  
Main Cylinder: 8" Bore, 6" Rod, 90" Stroke  
Oil Reservoir: 165 Gallons (**Oil Included with Installation**)  
**Included Option: Conveyor Style Hopper**

Performance rates, bale weights, and bale densities are subject to moisture content, material pre-bale densities, feed rates, and other variables in baling.

Please refer to the enclosed specifications sheet and drawing for complete dimensional/performance specifications

**ITEM TWO:**

**One New INTERNATIONAL BALER CORP. MODEL CY-48178 ABOVE GROUND, INCLINED, CLEATED, SLIDER BED, BALER FEED CONVEYOR**

Conveyor Size: 48" W x 178" L  
Conveyor Motor: 3 HP, **230 Volt, 3 Phase**, 60 Hz, TEFC, High Efficiency  
Belt Type: Heavy-Duty, 250 PVC  
Feed Hopper: Flared to Accept Waste  
**Includes: Baler Hopper to Match Conveyor and Conveyor Controls**

Please refer to the enclosed specifications sheet and drawing for more dimensional/performance specifications.

**TOTAL PACKAGE PRICE: DELIVERED AND INSTALLED ..... \$130,825.00**

**SHIPMENT:** Approximately 12 to 14 Weeks from Receipt of Order, Deposit, and Approved Drawings, Based upon Current Manufacturing Schedule. *Time for Shipment should be Confirmed at the Time of Order Placement.*

**ADDITIONAL ITEM:**

**ITEM A:**

**One New OIL COOLER for the Above Proposed Baler**

**ITEM A PRICE: DELIVERED AND INSTALLED .....ADD \$ 3,000.00**

Continued,

**Warranty: 1 Year or 2,000 Hours, whichever Comes First on Labor; 2 Years or 4,000 Hours, whichever Comes First, on Parts; and 3 Years or 6,000 Hours, whichever Comes First, on Structure**

**The Above Prices Include the Following:**

1. All Freight to Site, Including Any Freight Permits
2. All Rigging and Heavy Lifting Equipment
3. All Rigging and Assembly Labor
4. Hydraulic Oil for Baler Reservoir
5. Start-up Adjustments and Training

**Work by Others:**

1. All Main Power and Control Wiring except for Pre-wired Control Panels which are a Part of the Machines offered in this Proposal. *Customer to Provide Suitable Three Phase Electric Service to a Safety Disconnect Switch in Close Proximity to the Baler Control Panel Location. Customer's Electrician should be On Site at the Time of Baler Installation to make the Final Connection from the Disconnect Switch to the Baler Control Panel. Our Installation Personnel will then provide Start-Up Adjustment and Training. Additional Charges will be incurred if a Return Trip is Required to provide Start-Up Adjustment and Training.*
2. Any Required Building Modifications, Licenses, and/or Permits, ***Including Suitable Level Concrete Pads***

**NOTE:** The above Prices Do Not Include Baling Wire; ***we can Provide this to you at Additional Cost.*** You will be **Required** to have Enough Wire on Site at Time of Installation for the Technician to Perform the Start-up of the Baler.

**TERMS:** Full Balance Due at Time of Installation and Acceptance  
OR  
APPROVED LEASE PURCHASE

*Major Credit Cards are Accepted (subject to 3% credit card company processing fee)*

**NOTE: Terms are Subject to Credit Approval**

The above prices do NOT include state or local taxes, if applicable

*Ask your Tax Accountant about Possible Tax Benefits for the Purchase of Recycling Equipment in 2020.*

If this proposal is in conformity with your understanding, please sign this proposal and return to our office immediately, so we may begin processing your order.

Continued,



Page 4 of 4  
Mr. John W. Estep  
**STATE OF WEST VIRGINIA**

**Proposal No. 20-02-45**  
February 28, 2020



Should you have any questions, please do not hesitate to call me in the office at (215) 536-0700, Ext. 5300, or (267) 680-9037, on my cell phone at (267) 549-2330, or email me at [jonathan.mann@beequipment.com](mailto:jonathan.mann@beequipment.com).

Thank you.

Sincerely,

A handwritten signature in black ink that reads 'Jonathan Mann' followed by a stylized monogram 'JM'.

Jonathan Mann  
National Sales Manager  
BE EQUIPMENT, INC.

JM/LM

Enclosures:

1. BE Equipment, Inc. Brochure, Revised 12-17
2. BE Equipment, Inc. 2015 Service Brochure
3. International Baler Corp. Titan Series Horizontal Balers 2012 Brochure
4. International Baler Corp. Model Titan-60-XHP Closed Door Horizontal Series Specifications Sheet
5. International Baler Corp. CY-48178 Above Ground Conveyor Specifications Sheet, 8/8/2014
6. International Baler Corp. Titan-60-XHP (with CY-48178 Conveyor) GA Drawing, Dated 4-4-12
7. International Baler Corp. Limited Product Warranty February 23, 2018 (*Standard Warranty*)
8. International Baler Corp. Terms & Conditions of Sale, Issued January 1, 2016
9. BE Equipment, Inc. Standard Terms and Conditions January 3, 2014

PROPOSAL ACCEPTED BY: \_\_\_\_\_

With ADDITIONAL ITEM #: \_\_\_\_\_ DATE: \_\_\_\_\_

**Clerical errors are subject to correction.**



BE Equipment sells and services recycling, waste reduction and solid waste handling equipment. For over 35 years, we have provided the highest quality new and professionally reconditioned recycling and waste handling equipment available.

We offer a wide range of new, reconditioned and used recycling equipment including balers, conveyors, sorting systems, shredders, document destruction equipment, industrial compactors, core strippers, briquetters, shears, wire strippers and more...

We provide complete solutions for your recycling needs. Our experienced sales and service staff can show you how to maximize the revenue from your recycling efforts.



# BALERS

## Downstroke Balers

- Low cost
- High reliability
- Many models and sizes available



## Horizontal Multi-material Full Eject Balers

- Designed for difficult to bale materials
- Heavy duty manual tie for paper, plastic and non-ferrous materials



## Closed Chamber Horizontal Balers

- Manual and automatic feed
- Various feed opening and bale sizes available



## Wide Mouth Horizontal Open End Auto-tie Balers

- Fast and fully automatic
- Large feed opening and bale sizes
- Conveyor fed
- Volumes up to 60 tons per hour



## Horizontal Narrow Mouth Open End Auto-tie Baler

- Fast and fully automatic
- Various feed opening and bale sizes available



## Two Ram Horizontal Balers

- Fully automatic
- Auto-tie
- High volumes of multi-materials
- Paper, plastic, corrugated and non-ferrous materials

# We Provide Solutions.

Our experienced sales and service staff can show you how to maximize the revenue from your recycling efforts. We can assist you with all of your recycling and waste handling equipment needs.

- Extensive inventory of new, used and reconditioned recycling equipment
- Extensive parts and wire inventory – including hard to find items
- Fully staffed reconditioning shop
- Reconditioned equipment warranties
- Experienced technical sales staff
- Over 35 years experience
- Purchase, leasing and rental options available
- Personal and professional attention
- Professional, factory-trained site service technicians
- Installation and equipment relocation
- Planned maintenance programs
- Training and startup
- Equipment liquidation and removal

We offer NEW and USED equipment suited for a wide range of applications and environments including but not limited to:

- Department Stores
- Retail Centers
- Manufacturing Facilities
- Distribution Centers
- Fulfillment Centers
- Document Destruction Facilities
- E-waste Destruction Facilities
- Printers
- Binders
- Converters
- Container and Folding Carton Plants
- Paper Recyclers
- Plastic Recyclers
- Non-ferrous Metal Recyclers
- Municipal and Private Recycling Centers
- Single Stream and Dual Stream Recyclers
- Construction and Demolition Recyclers



PO Box 139  
Quakertown, PA 18951  
PA: (215) 536-0700  
NJ: (732) 846-9920  
MD: (410) 661-1333  
[sales@beequipment.com](mailto:sales@beequipment.com)  
[www.beequipment.com](http://www.beequipment.com)

# BE Equipment, Inc.

## Sales:

- ✓ Our Technical Sales Team brings extensive experience of various applications to meet your needs
- ✓ We evaluate your individual needs and recommend practical solutions
- ✓ National recognition for Sales Excellence gives confidence of satisfaction to our customers
- ✓ Extensive Equipment Inventory in our warehouse means you're up and running more quickly

## Service:

- ✓ We stay with you after the sale
- ✓ Expert, In-house Road Service Team gets your Equipment up and running
- ✓ Fully stocked Service Vehicles get parts, tools and technicians to your door
- ✓ Planned Maintenance Programs keep track of your regular service needs
- ✓ Technical team can rebuild equipment on your site or in our shop
- ✓ Experienced team can relocate your equipment
- ✓ Technical Service Assistance is available over the phone. Call us first!

## Parts and Supplies:

- ✓ Fully stocked inventory gets parts to you quickly
- ✓ Baler Wire stocked in all types and sizes

# Sales Department

The BE Equipment, Inc. Sales Department finds solutions.

We have over 30 years of experience in recycling centers, distribution centers, transfer stations, department stores, printing companies, supermarkets, non-ferrous scrap yards, municipalities and more.

## Equipment includes:

- ✓ Balers
- ✓ Shredders
- ✓ Conveyors
- ✓ Single Stream Sorting Systems
- ✓ Pneumatic Trim Collection Systems
- ✓ Compactors
- ✓ Briquetters
- ✓ Metal Working Equipment
- ✓ Wire Strippers
- ✓ Alligator Shears



The Se  
aspect  
Hydrau  
you nee  
initial in

Service:

- ✓ Plan
- ✓ Reli
- ✓ Equ
- ✓ Equi
- ✓ Shop
- ✓ On-S
- ✓ Field
- ✓ Serv
- ✓ Lap-
- ✓ Phon
- ✓ Phon
- ✓ Parts

Planned I  
Quarter  
months.  
waste ha

Planned

B E Equipment, Inc.  
1775 Wentz Road  
Quakertown, PA 18951

**BE**  
**EQUIPMENT, INC.**

*Established 1983*

**Your One-Stop Source  
for All of Your  
Recycling Equipment Needs**

**A Full Service Company  
providing:**

- Sales
- Service
- Planned  
Maintenance
- Parts
- Baling Wire

**PA: 215-536-0700**

**NJ: 732-846-9920**

**MD: 410-661-1333**

**FX: 215-536-3783**

**[www.beequipment.com](http://www.beequipment.com)  
[service@beequipment.com](mailto:service@beequipment.com)**

***Serving the Recycling Industry***



# Titan Series

## Horizontal Balers

The Titan is the newest generation of our successful LD Series horizontal balers. Like the classic LD, the Titan is an efficient and affordable choice for baling multiple products and features a heavy-duty solid plate construction with advanced hydraulics and PLC controls. To get the most out of your next baler purchase, call IBC today and put one of our dependable balers to work for you.



Titan-6-EC  
With Optional Pit Conveyor



**INTERNATIONAL BALER CORPORATION**

# Titan Series

## Features:



PERFORMANCE (Lbs.)			
	OCC	ONP	PET
TITAN-6-EC	Up to 1,200	Up to 1,600	Up to 900
TITAN-60-EC	Up to 1,300	Up to 1,700	Up to 950

\*Bale weights are subject to moisture content.



- Heavy duty welded construction
- Heavy duty hydraulic system with TEFC motor
- Integrated disconnect providing for lock-out/tag-out procedures
- Multi-material High Density Bales, **without pre-conditioning or fluffing**
- Automatic cycling
- PLC-equipped electrical panel UL Listed
- Slotted bale door and wire guides for easy bale tie-off
- Meets or exceeds all current ANSI Z 245.5 safety standards
- Safety release "hydraulically Operated Clam-shell" door lock
- Fixed and guided wear blocks made from self-lubricating bearing-grade composite Nylatron.
- Maintenance doors allow for easy access to flip or change the wear blocks.
- Floor Liner Plates (AR400) and adjustable wear shoes on bottom of presshead. The shoes may be shimmed or replaced without removing the presshead.
- Tongue-and-groove floor.
- Bolt-in and replaceable wire trays.
- AR400 Presshead top plate.
- Adjustable serrated shear blade can be flipped to maximize useful life.
- Micrologix 1100 PLC with built-in Ethernet.
- Main bore laser positioning.
- 20HP Motor, featuring unique hydraulic circuit using twin D08 manifold with soft start and stop (Regen models only).
- Non-Regen Models Available
- Frame features single-wall and keyed construction for superior strength.
- Upper and lower hopper sensors are standard.
- Multiple mode selections.
- New style springless bale dogs.
- Available with optional oil cooler.

### SPECIFICATIONS

	OVERALL HEIGHT	OVERALL WIDTH	OVERALL LENGTH	HOPPER SIZE (L X W)	HP	SYSTEM PRESSURE (PSI)	MAIN BORE	TOTAL FORCE	CYCLE TIME
TITAN-6-EC	103"	86"	202"	58" X 35"	20	3,000	8"	150,800	32
TITAN-60-EC	101.5"	86"	223"	56" X 40"	30	3,500	8"	175,929	35



### INTERNATIONAL BALER CORPORATION



1775 Wentz Road • P.O. Box 139  
 Quakertown, PA 18951  
 PA: (215) 536-0700 • NJ: (732) 846-9920  
 MD: (410) 661-1333 • FAX: (215) 536-2999  
[www.beequipment.com](http://www.beequipment.com)

As part of our continuing product improvement and quality assurance programs, specifications are subject to change without notice and without incurring responsibility to units previously sold.



# International Baler Corporation

Jacksonville, Florida

## MODEL Titan-60-XHP CLOSED DOOR HORIZONTAL SERIES

### MACHINE DIMENSIONS

Length	223"
Width	86"
Height	101.5"
Hopper Size (L x W)	56 x 40
Shipping Weight	19,000 Lbs.

### STRUCTURAL

Main Frame	Welded Frame of Heavily Reinforced plate
Floor Structure	AR 400 Liner Plates, Replaceable
Shear Blade	Replaceable T-1 Alloy Steel
Hoppers	Steel Plate Fabrication with Access Door

### ELECTRICAL

Main Motor	30 HP/1,800 RPM/460 Volt/3 Phase/TEFC/High Efficiency
Main Enclosure	NEMA 12 Rated
Operators Controls	Programmable Controller
Control Circuit	120 volts
Cooler Fan	NA
Control Switches	Proximity Switches
Photocell	Infrared Type

### HYDRAULIC

JIC Standard Hydraulics	
Main Pumps	50 GPM Total Flow
Maximum System Pressure	4,000 PSI
Main Cylinder	8" Bore, 90" Stroke, 6" Rod
Door Cylinder	4" Bore, 8" Stroke, 2" Rod
Total Force	201,062 Lbs.
Platen Pressure	116 PSI
Oil Reservoir Capacity	165 Gallons

### STANDARD FEATURES

Programmable Controller  
UL Listed Control Panel

### OPTIONS

Oil Heater  
Baling Wire  
Hydraulic Oil  
Special Electric Voltages available at surcharge. Consult factory for pricing.



\*Machine depicted is representative of series and may not be actual model.

*The LD Series is a "Wide Box" closed-door design. The "SD" Series is designed for general recyclable products like OCC, ONP, plastics, and cans. The "XHD" Series is designed for non-ferrous applications.*

### PERFORMANCE

Bale Size	30 x 48 x 60
Bale Volume	50 Cubic Feet Expanded (Approximate)
Cycle Time	33 Seconds
Short Stroke	19 Seconds
Production Capacity	3,975/11,018 Cubic Feet

MATERIAL	IN-FEED DENSITY (Estimated)	TONS PER HOUR	BALE WEIGHTS
OCC	2.5#/FT <sup>3</sup>	Up to 3.5 Tons	Up to 1,400 Lbs.
News	3#/FT <sup>3</sup>	Up to 4.5 Tons	Up to 1,800 Lbs.
P.E.T.	1#/FT <sup>3</sup>	Up to 2.5 Tons	Up to 1000 Lbs.

\* Performance rates, bale weights (based on actual customer surveys) and bale densities are subject to moisture content, material pre-bale densities, feed rates and other variables in baling.

**WE RECOMMEND YOU PURCHASE BALING WIRE AND HYDRAULIC OIL WITH ORDER.**

Due to Equipment Upgrades, specifications and nominal dimensions are subject to change without notice.



1775 Wentz Road • P.O. Box 139 • Quakertown, PA 18951  
PA: (215) 536-0700 • NJ: (732) 846-9920 • MD: (410) 661-1333  
FAX: (215) 536-2999 • sales@beequipment.com • www.beequipment.com





# International Baler Corporation

Jacksonville, Florida

## CY-48178

Above Ground Conveyor

### CONVEYOR DIMENSIONS

Length	178"
Belt Width	48"
Incline Angle	35°
Hopper	1.5 Cubic Yard
Shipping Weight	5,000 Lbs.

### STRUCTURAL

Main Frame	Sidewall is Solid Plate Steel. Slider Bed Floor is Reinforced Rectangular Tube.
Belt	Heavy Duty PVC 3" Bolt-On Metal Cleats on 48" Centers

### ELECTRICAL

Main Motor	3 HP
Motor Type	TEFC, High Efficiency
Standard Voltage	460v-60hz-3ph
Controls	Standard w/out controls



\*Unit depicted is representative of series and may not be actual model.

### STANDARD FEATURES

- 10" Head & Tail Pulleys
- Take Up Assemblies for Belt Tracking
- 20" Side Walls
- Two Emergency Stop Controls
- 60:1 Shaft Mounted Gearbox
- 75 Feet Per Minute (approximate)
- Cleat-out Access @ Conveyor Base

### OPTIONS

- VSD (Variable Speed Drive)
- Stand Alone Controls
- Heavy Duty 5HP Configuration
- Personnel Safety Pull Cable System
- Safety Overload Section
- Extreme Cold Weather Package

**IBC builds conveyors in standard widths of 36", 48" & 60". They are available in many different lengths and are designed to work efficiently with our balers.**

**Custom lengths and widths are also available, as well as Pit Conveyors.**

Specifications and nominal dimensions are subject to change without notice.



1775 Wentz Road • P.O. Box 139 • Quakertown, PA 18951  
 PA: (215) 536-0700 • NJ: (732) 846-9920 • MD: (410) 661-1333  
 FAX: (215) 536-2999 • sales@beequipment.com • www.beequipment.com

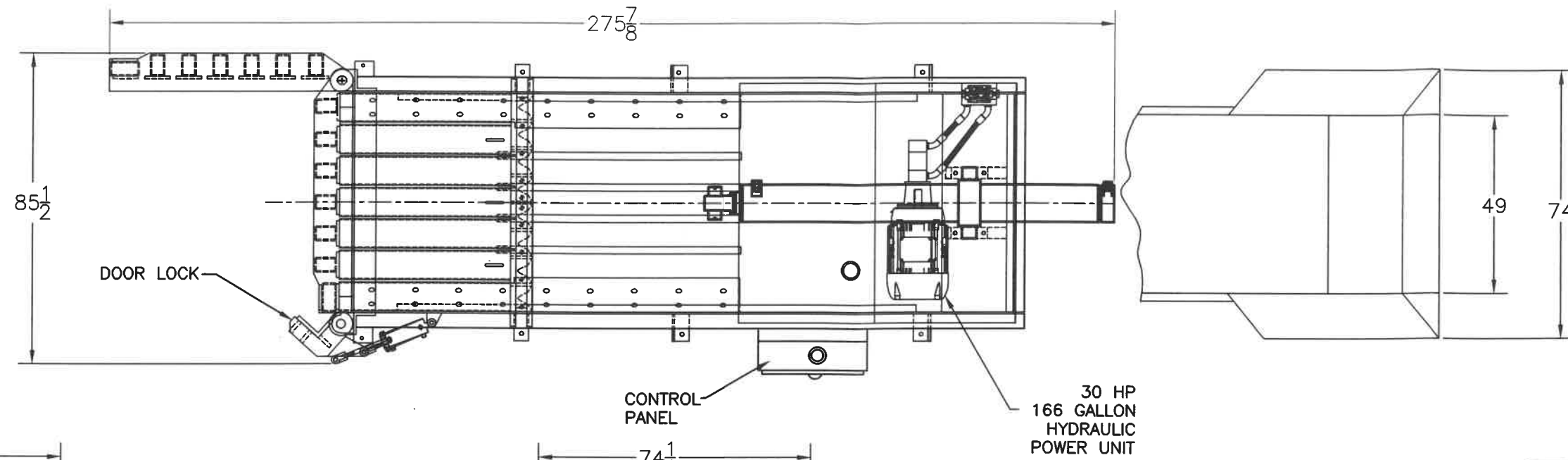

**FOR APPROVAL**  
 DATE \_\_\_\_\_  
 VOLTAGE \_\_\_\_\_  
 BY \_\_\_\_\_

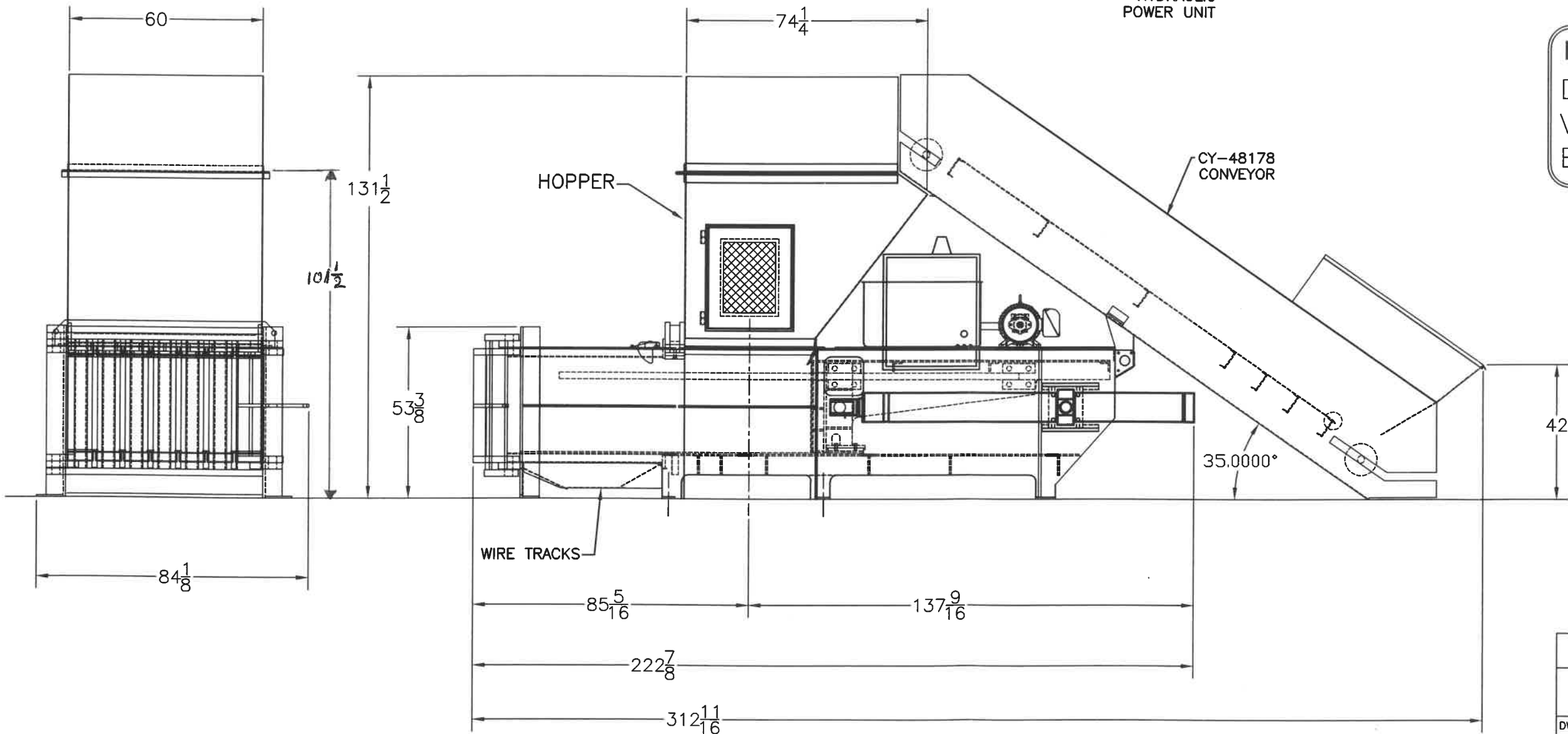

INTERNATIONAL BALER CORP. JACKSONVILLE, FLORIDA			
<b>TITAN-60-XHP</b> GENERAL ARRANGEMENT			
DW. BY: RC	DATE: 4-4-12	DWG. NO.	REV. <input type="checkbox"/>
CH. BY:	U.O.M.	SHEET OF	
CUSTOMER:			
REQ'D VOLTAGE:			



# International Baler Corporation

Jacksonville, Florida

## LIMITED PRODUCT WARRANTY

1. **INTERNATIONAL BALER CORPORATION (IBC)** hereby warrants to the original Purchaser that its equipment will be free from defects in material and workmanship under normal operating conditions of use and service for **one (1) year or two thousand (2000) hours on components and three (3) years or six thousand (6000) hours on structural** beginning from the date of installation or ninety (90) days from the date of shipment, whichever occurs first (the "Applicable Warranty Period"). **Labor is covered for a period of six (6) months.**
2. The limited warranty contained in Paragraph 1 does not extend to any equipment, accessories or component parts of any other manufacturer beyond any warranties offered by such manufacturer.
3. No claims under this limited warranty will be valid unless the Purchaser notifies IBC in writing within a reasonable period of time of its discovery of any defect, but in any event prior to the expiration of the Applicable Warranty Period.
4. This limited warranty does not cover ordinary maintenance items including, without limitation, wearstrips, filters, lubricants, adjustments to limit switches, pressure switches, timers, counters, inserter rollers, twister hooks, wire roller, valve coils/solenoids, sharks teeth/cutter knives, and guide bars. Nor does this limited warranty cover damage to the equipment caused by alterations, normal wear and tear, abuse, improper use, or improper electrical voltage or electrical service provided by the Purchaser.
5. No Warranty shall exist if unauthorized alterations have been made by the Purchaser or user, or if stated capabilities are exceeded. No warranty shall exist if the routine maintenance requirements of the operating manual are not followed. No warranty shall exist if the Equipment is not annually inspected under the Preventative Maintenance contract by IBC or an Authorized Dealer. Warranties related to the hydraulic system of the equipment will be void if the hydraulic oil does not meet the hydraulic oil specification stated in the operating manual.
6. **THE LIMITED WARRANTY CONTAINED IN PARAGRAPH 1 IS EXCLUSIVE AND IS IN LIEU OF ALL OTHER EXPRESS AND IMPLIED WARRANTIES WHATSOEVER, INCLUDING, WITHOUT LIMITATION, IMPLIED WARRANTIES OF MERCHANTABILITY AND FITNESS FOR A PARTICULAR PURPOSE. IBC SHALL NOT BE LIABLE FOR ANY LOSS OR DAMAGE CAUSED BY DELAY IN FURNISHING THE EQUIPMENT, OR FOR ANY ENVIRONMENTAL CONTAMINATION TO SOIL OR PROPERTY DUE TO OIL LEAKS OR SPILLS FROM THE EQUIPMENT.**
7. IBC will repair or replace, at its option, any equipment (or parts thereof) that are covered by this limited warranty and which are found to be defective. No such repair or replacement will extend the Applicable Warranty Period. Repair and replacement shall be the Purchaser's sole and exclusive remedy under this policy. IBC will ship repair or replacement parts under this warranty at Purchaser's expense. When a warranty claim arises, where equipment or parts are to be returned or replaced, Purchaser must contact IBC to arrange return shipment to IBC, with freight prepaid by Purchaser. When defective parts are to be returned, the Purchaser will be charged for the replacement parts and will receive a credit when the defective parts are returned. These parts should be shipped to IBC within ten business days from receipt of the replacement parts. The risk of loss or damage to any equipment returned to IBC shall be with Purchaser. If parts are not returned within ten days, IBC will not issue a warranty credit to the Purchaser's account.



# International Baler Corporation

Jacksonville, Florida

8. **THE REMEDY OF REPAIR OR REPLACEMENT PROVIDED HEREIN IS PURCHASER'S EXCLUSIVE REMEDY IN THE EVENT OF BREACH OF THIS LIMITED WARRANTY. IN ADDITION, IBC SHALL NOT BE LIABLE FOR ANY INCIDENTAL, CONSEQUENTIAL OR SPECIAL DAMAGES OR FOR ANY LOSS, DAMAGE OR EXPENSE ARISING FROM THE SALE, USE OR INSTALLATION OF THE EQUIPMENT, INCLUDING LOSS OF PROFITS, LOSS OF PRODUCTION TIME, LOSS OF GOODWILL, INCREASED FREIGHT, SHIPPING AND HANDLING, OR FROM ANY OTHER CAUSE WHATSOEVER, WHETHER BASED ON WARRANTY (EXPRESS OR IMPLIED) OR OTHERWISE BASED ON CONTRACT, OR IN TORT, OR REGARDLESS OF ANY ADVISE OR REPRESENTATIONS THAT MAY HAVE BEEN MADE BY IBC CONCERNING THE SALE, USE OR INSTALLATION OF THE PRODUCT.**
9. IBC reserves the right to change the design and construction of the equipment when, in its exclusive opinion, such a change represents an improvement to the equipment.
10. In delivering the equipment, IBC has relied upon Purchaser's promise to properly train and supervise its employees in the operation and use of the equipment. IBC has further relied on Purchaser's promise to prohibit its employees from placing any of their limbs within the chamber of the equipment, and to only utilize an approved service technician in performing service on the equipment. Purchaser's promise to advise IBC immediately as to any problems that you experience with your equipment.
11. This Limited Product Warranty, as well as the relationship between you and IBC, shall be governed in all respects by the laws of the State of Florida without regard to conflict of law provisions. You agree any claim or dispute you may have against IBC must be brought in the Fourth Judicial Circuit, in and for Duval County, and no other. You agree to submit to the personal jurisdiction of the Fourth Judicial Circuit, in and for Duval County, for the purpose of litigating all such claims or disputes. **YOU AGREE THIS CHOICE OF LAW AND FORUM SELECTION CLAUSE IS MANDATORY, EXCLUSIVE, AND SUPERSEDES ANY AND ALL COMPETING CHOICE OF LAW AND/OR FORUM SELECTION CLAUSES, TO INCLUDE ANY SUCH PROVISIONS AGREED TO BY YOU AND ANY DISTRIBUTOR/DEALER OF IBC'S PRODUCTS.**

All claims you bring against IBC must be resolved in accordance with the provisions of this Limited Product Warranty. All claims filed or brought contrary to this Limited Product Warranty shall be considered improperly filed. Should you file a claim contrary to this Limited Product Warranty, IBC may recover attorneys' fees and costs incurred in removing the improperly filed claim, provided IBC has notified you in writing of the improperly filed claim and you fail to promptly withdraw the same.



**International Baler Corporation**  
Jacksonville, Florida

Issued: January 1, 2016

**TERMS & CONDITIONS OF SALE**

The following terms and conditions of sale become a part of the proposal and any subsequent sale of equipment by International Baler Corporation, hereinafter referred to as "we", "us", "our", etc. whether the equipment be purchased or leased directly from us or our Agent, Representative, or Dealer or from a Leasing Company. "Buyer" as used herein includes not only the purchaser but also the original user of the equipment.

**All orders accepted by International Baler Corporation are subject to the Terms and Conditions of International Baler Corporation. Any other or special terms and conditions must be accepted by International Baler Corporation, in writing, prior to International Baler accepting any order.**

**PRICES**

1. Prices are firm for a period of thirty (30) days from the date of our published price schedule or letter proposal, unless otherwise stated, provided shipment will be accepted within six (6) months of the date of our price schedule or letter proposal.
2. Prices are F.O.B. **Jacksonville, Florida**, unless otherwise stated on proposal.
3. At our option, prior to shipment of the equipment, we may require the utilization of a financing statement and security agreement or Irrevocable Letter of Credit.

**ACCEPTANCE:**

1. All orders are subject to acceptance by International Baler Corp. in Jacksonville, Florida. Typographical and clerical errors in quotations and acknowledgments are subject to corrections.
2. For credit verification, we may require credit references, a financial statement or other financial information from the Buyer.

**CHANGES IN DESIGN:**

1. As we constantly strive to improve our products, specifications are necessarily subject to change without notice. We are not obligated to apply any change or improvement on equipment previously manufactured.
2. Changes in design or construction of equipment made at the request of the Buyer after the order has been accepted, or, in the case of custom equipment orders after the approval of certified drawings, will be made at the expense of the Buyer under terms to be mutually agreed.

**SHIPMENT:**

1. We reserve the right to select the transportation carrier which has equipment to meet the requirements of our shipping facility and to handle our equipment.
2. We are not responsible for shipping delays beyond our reasonable control. It is understood that we are free of any and all liability and penalty for delayed shipments caused by transportation delays, inability to obtain necessary components and materials for fabrication and assembly, acts of Buyer, labor disturbances, wars, riots, fires, accidents, explosions, floods, epidemics, quarantine, adverse weather, governmental acts or regulations or acts of God.

**SERVICE:**

1. Before the equipment is placed in operation, start-up and training service by one of our field service engineers is available and recommended. During this start-up, final equipment adjustments are made and the Buyer and his operating and maintenance personnel are instructed. This service is charged at prevailing rate.
2. One (1) Owner's Manual covering Installation, Operation, Maintenance Instructions and Spare and Replacement Parts lists are furnished with the equipment purchased. Additional manuals may be purchased at the prevailing nominal charge.

**International Baler Corporation**

5400 Rio Grande Avenue  
P.O. Box 6922 (zip 32236)  
Jacksonville, Florida 32254

Tel: 904-358-3812  
800-231-9286  
Fax: 904-358-7013  
Email: [sales@intl-baler.com](mailto:sales@intl-baler.com)  
Web: [www.intl-baler.com](http://www.intl-baler.com)



# International Baler Corporation

Jacksonville, Florida

## GENERAL:

1. Additional costs as the result of special hydraulic, electronic or pneumatic components or other special arrangements required by local standards or codes will be the responsibility of the Buyer.
2. The equipment is skidded, if necessary, for normal truck transportation. Optional skidding, crating, export boxing, packing or painting of a special type or nature can be provided at an extra charge.
3. These terms and conditions supersede and take precedence over all the provisions of the Buyer's purchase order or any similar document of the Buyer in conflict with these terms and conditions of sale.
4. These terms and conditions of sale, our warranty, our published current literature and specifications and our acceptance of the Buyer's order define our entire obligation with respect to any sale of our equipment.
5. All information in the proposal is confidential, prepared solely for the Buyer's consideration to purchase our equipment. Transmission of all or part of the proposal information to others or use by Buyer for other purposes is unauthorized without written consent.
6. All claims for shortages or damaged material must be made within ten (10) days of receipt of the shipment in order to be honored. **Any damage to a shipment must be noted on the bill of lading at the time of delivery.** Notification must be made to International Baler Corp., with reference to the invoice number and a copy of the bill of lading, via email or fax.
7. There will be a 20% restocking charge for all standard returned parts. Return of standard parts are only accepted for ten (10) days from date of shipment and notification must be made to International Baler Corporation via email or fax.
  - a. Non-standard parts are not covered by this policy and written authorization must be first obtained from International Baler Corporation.
8. In the case of a cancellation of an order by you, the following charges will be made to your account:
  - a. After placement, 10% of the contract price.
  - b. After entering Engineering, 15% of the contract price.
  - c. After entering Shop Production, 35% of the contract price.
  - d. Completion and prior to shipment, 100% of the contract price, unless otherwise agreed to by International Baler Corporation.

**NOTE: ACCOUNTS NOT PAID WITHIN TERMS OF INVOICE DATE WILL BEAR A SERVICE CHARGE OF TWO (2%) PERCENT PER MONTH ON THE UNPAID BALANCE DUE OR MAXIMUM ALLOWED BY LAW.**

## **INTERNATIONAL BALER CORPORATION – PAYMENT TERMS**

### STANDARD TERMS:

1. 35% Deposit with Purchase Order
2. 55% Prior to Shipment
3. 10% Net 30 Days from date of shipment with Credit Department Approval.

### **International Baler Corporation**

5400 Rio Grande Avenue  
P.O. Box 6922 (zip 32236)  
Jacksonville, Florida 32254

Tel: 904-358-3812  
800-231-9286  
Fax: 904-358-7013  
Email: [sales@intl-baler.com](mailto:sales@intl-baler.com)  
Web: [www.intl-baler.com](http://www.intl-baler.com)

## TERMS AND CONDITIONS

Unless and to the extent otherwise specified in the proposal of which this document is part, the following terms and conditions shall apply to this Proposal of BE Equipment, Inc. ("Company") and to any order or contract resulting from this Proposal:

**PRICES:** All prices exclude sales, use, occupation, license, excise and other taxes in respect to manufacture, sale or delivery and unless otherwise stated in this Proposal are firm for a period of thirty (30) days from date of quotation, provided shipment will be accepted within six (6) months of date of quotation. Prices may be adjusted to current prices at time of shipment on all shipments made after six (6) months from date of receipt of purchase order. Deposits on any order cancelled after 30 days shall not be refundable.

**PAYMENT:** Unless otherwise specified in our proposal, payment terms are due on presentment of our invoice. Amounts outstanding over thirty days are subject to a surcharge of one and one-half percent (1-1/2%) per month (equivalent to 18% per year) on the outstanding balance. In the event Company is required to utilize the services of an attorney or collection agent to recover any sums due to Company, or defend any claim related to a sale resulting from this proposal, Company shall have the right to recover from Buyer all costs of collection, including but not limited to reasonable attorney's fees and costs.

**TAXES:** Liability for all taxes, licenses, or other fees imposed by any municipal, state or governmental authority upon the production, sale, shipment and/or use of products or services covered by this proposal, and value-added taxes of any kind, shall be assumed and paid for by the Buyer and the Buyer shall indemnify Company against any such liability. Applicable sales and/or use taxes are NOT included in the proposals and will be billed by Company unless a suitable and valid exemption certificate is furnished by the Buyer at the time of order placement.

**CANCELLATION AND RETURNED EQUIPMENT:** Orders may be cancelled by Buyer only with Company's written consent and upon payment of cancellation charges as determined by Company including costs and expenses incurred by the Company in carrying forward the order to the date of Company's agreement to terminate.

**FINANCIAL RESPONSIBILITY OF BUYER:** If at any time before shipment the financial responsibility of Buyer becomes impaired, or unsatisfactory to Company, cash payment or satisfactory security may be required by Company before shipment, and in the event of bankruptcy or insolvency laws, Company shall be entitled to cancel any order then outstanding and shall receive reimbursement and proper cancellation charges.

**DELIVERY:** Except as otherwise specified in this Proposal, delivery will be F.O.B. point of shipment. Time of delivery is an estimate only and is subject to abnormal conditions of manufacture and supply. The Company shall in no event be liable for any alleged damages, expenses, or losses for any delay, however and by whomsoever caused, and no order or contract resulting here from shall be cancelable on account of any delays caused by fires, acts of God, strikes, labor difficulties, acts of governmental agencies or military authorities, delays in transportation or procuring materials, or causes of any kind beyond the Company's control.

**WARRANTY:** ALL NEW MACHINERY QUOTED ON THIS PROPOSAL IS SUBJECT TO THE STANDARD GUARANTEE OF THE MANUFACTURER THEREOF, IF ANY. OTHER THAN SUCH MANUFACTURER'S WARRANTY, COMPANY EXPRESSLY DISCLAIMS ALL WARRANTIES, EXPRESS OR IMPLIED, INCLUDING BUT NOT LIMITED TO THE WARRANTIES OF MERCHANTABILITY FITNESS FOR A PARTICULAR USE, AND SELLER FURTHER EXPRESSLY WAIVES AND DISCLAIMS ANY LIABILITY FOR INCIDENTAL OR CONSEQUENTIAL DAMAGES, INCLUDING WITHOUT LIMITATION, LOSS OF PROFITS, LOSS OF PRODUCTION TIME, LOSS OF GOODWILL, INCREASED FREIGHT, SHIPPING AND HANDLING, OR FROM ANY OTHER CAUSE WHATSOEVER, WHETHER BASED ON WARRANTY (EXPRESS OR IMPLIED) OR OTHERWISE BASED ON CONTRACT OR TORT, REGARDLESS OF ANY ADVICE OR REPRESENTATION THAT MAY HAVE BEEN MADE BY COMPANY CONCERNING THE SALE, USE OR INSTALLATION OF THE EQUIPMENT. CUSTOMER UNDERSTANDS AND ACKNOWLEDGES THAT COMPANY DOES NOT EXTEND ANY WARRANTY WHATSOEVER, AND AGREES TO RELY SOLELY ON THE WARRANTY OF THE MANUFACTURER, IF ANY.

COMPANY SHALL NOT BE LIABLE FOR ANY LOSS OR DAMAGE CAUSED BY DELAY IN FURNISHING THE EQUIPMENT, OR FOR ANY ENVIRONMENTAL CONTAMINATION TO SOIL OR PROPERTY DUE TO OIL LEAKS OR SPILLS FROM THE EQUIPMENT.

COMPANY MAKES NO WARRANTIES REGARDING PRODUCTS OR MATERIALS MANUFACTURED BY IT OR OTHERS (INCLUDING WITHOUT LIMITATION WARRANTIES AS TO MERCHANTABILITY AND FITNESS FOR A PARTICULAR PURPOSE), EITHER EXPRESS OR IMPLIED, EXCEPT AS PROVIDED HEREUNDER.

**TITLE AND LIEN RIGHTS:** The equipment shall remain personal property, regardless of how affixed to any realty or structure. Title thereto

Continued on Reverse Side

shall remain in the Company until the price (including any notes therefore) has been fully paid in cash. The Company shall in event of Customer's default, have all rights of repossession and other rights otherwise available to a conditional seller under the laws applicable thereto.

**SERVICE CHARGE:** Should the Buyer request the service of an erector or serviceman, except as specifically provided for and included in the price in the Proposal, such service will be quoted separately.

**ACCEPTANCE:** Unless otherwise expressly stated herein, or unless modified or withdrawn by the Company prior to acceptance, this Proposal shall expire thirty (30) days after its date.

**HOLD HARMLESS:** Notwithstanding any other terms, obligations and conditions contained in this Agreement, the Customer agrees to defend, hold harmless and indemnify the Seller (BE Equipment, Inc.) against any and all losses, claims, actions, damages, liabilities, costs and expenses in connection with loss of life, personal injury, damages or any other losses or injuries which may arise from, and occasioned wholly or in part by any act or omission or by the fault of the Customer, its employees, representatives or subcontractors related to the installation, start-up and/or training of any employees or other individuals who operate the equipment which Customer has elected not to have BE Equipment, Inc. install, start-up and train their operator(s) on the operation of.

**ENTIRE CONTRACT:** No acceptance by Company of any order shall be deemed to be an acceptance of any provision of Buyer's purchase order form. This writing constitutes the entire agreement and understanding between the Buyer and the Company as of the date of acceptance by Company and shall not be modified thereafter in any way except by a writing executed by a person duly authorized by Company to execute the same.

**GOVERNING LAW:** This contract is executed in the Commonwealth of Pennsylvania, and shall be governed and construed in all respects pursuant to the laws of the Commonwealth of Pennsylvania without regard to the law of conflicts of laws, and without regard to any rule of interpretation or construction as to which party drafted this Agreement. In the event that suit is required to be brought by Company to enforce any of the terms of this Agreement, Buyer irrevocably consents to the jurisdiction and venue of the Court of Common Pleas of Bucks County, Pennsylvania, or of such other jurisdiction in which Company maintains its principal place of business.

COMPANY'S ACCEPTANCE OF BUYER'S ORDER IS EXPRESSLY LIMITED TO ACCEPTANCE OF THE TERMS AND CONDITIONS STATED ABOVE, AND ON THE FACE, WHICH ARE A PART OF THIS ORDER. ANY ADDITIONAL OR DIFFERENT TERMS PROPOSED BY THE SELLER ARE OBJECTED TO AND ARE HEREBY REJECTED IN THE ABSENCE OF A VALID CHANGE ORDER SIGNED BY COMPANY.