



Purchasing Division
 2019 Washington Street East
 Post Office Box 50130
 Charleston, WV 25305-0130

State of West Virginia
 Request for Quotation
 13 - Equipment

RECEIVED

2020 FEB 24 AM 10:17

WV PURCHASING
 DIVISION

Proc Folder: 686584

Doc Description: Addendum No.1 - Terminal Trailer

Proc Type: Central Purchase Order

Date Issued	Solicitation Closes	Solicitation No	Version
2020-02-21	2020-02-24 13:30:00	CRFQ 0603 ADJ2000000011	2

BID RECEIVING LOCATION

BID CLERK
 DEPARTMENT OF ADMINISTRATION
 PURCHASING DIVISION
 2019 WASHINGTON ST E
 CHARLESTON WV 25305
 US

VENDOR

Vendor Name, Address and Telephone Number:
 West Virginia Tractor Company
 P.O. Box 473
 Charleston, WV 25322
 304-346-5301

FOR INFORMATION CONTACT THE BUYER

John W Estep
 (304) 558-7839
 john.w.estep@wv.gov

Signature X  PEIN # 550621655 DATE 2-21-20

All offers subject to all terms and conditions contained in this solicitation

ADDITIONAL INFORMATION:

Addendum No.1 is Issued to:

1. Respond to Vendor Question per attached .

No Other Changes

INVOICE TO		SHIP TO	
STATE FINANCE ADJUTANT GENERALS OFFICE 1703 COONSKIN DR		(540) 686-6432 WV ADJUTANT GENERAL STORAGE FACILITY 1315 AIRPORT ROAD	
CHARLESTON	WV25311-1085	MARTINSBURG	WV 25401
US		US	

Line	Comm Ln Desc	Qty	Unit Issue	Unit Price	Total Price
1	SEMI-TRAILER MOVER / TRAILER DOLLY	1.00000	EA		

Comm Code	Manufacturer	Specification	Model #
25181611			

Extended Description :

SEMI-TRAILER MOVER / TRAILER DOLLY

SCHEDULE OF EVENTS

Line	Event	Event Date
1	Technical Questions due by 10:00am	2020-02-18

ADJ2000000011	Document Phase Final	Document Description Addendum No.1 - Terminal Trailer	Page 3 of 3
---------------	--------------------------------	---	------------------------------

ADDITIONAL TERMS AND CONDITIONS

See attached document(s) for additional Terms and Conditions

SOLICITATION NUMBER: CRFQ ADJ2000000011
Addendum Number: 1

The purpose of this addendum is to modify the solicitation identified as CRFQ ADJ2000000011 ("Solicitation") to reflect the change(s) identified and described below.

Applicable Addendum Category:

- Modify bid opening date and time
- Modify specifications of product or service being sought
- Attachment of vendor questions and responses
- Attachment of pre-bid sign-in sheet
- Correction of error
- Other-

Additional Documentation:

1. Modify Specification 6.1 from 60 working days to 120 working days
2. The bid opening remains on 02/24/2020 at 1:30 pm.

Terms and Conditions:

1. All provisions of the Solicitation and other addenda not modified herein shall remain in full force and effect.
2. Vendor should acknowledge receipt of all addenda issued for this Solicitation by completing an Addendum Acknowledgment, a copy of which is included herewith. Failure to acknowledge addenda may result in bid disqualification. The addendum acknowledgement should be submitted with the bid to expedite document processing.

CRFQ ADJ200000011

ADDENDUM NO. 1

Questions:

Q1: 6.1 We request the delivery time be increased from 60 working days to 120 working days.

A1: We are agreeable to increasing the delivery time as requested

Other Information:

1. The bid opening remains on 02/24/2020 at 1:30 pm.

ADDENDUM ACKNOWLEDGEMENT FORM
SOLICITATION NO.: CRFQ ADJ2000000011

Instructions: Please acknowledge receipt of all addenda issued with this solicitation by completing this addendum acknowledgment form. Check the box next to each addendum received and sign below. Failure to acknowledge addenda may result in bid disqualification.

Acknowledgment: I hereby acknowledge receipt of the following addenda and have made the necessary revisions to my proposal, plans and/or specification, etc.

Addendum Numbers Received:

(Check the box next to each addendum received)

- | | |
|--|--|
| <input checked="" type="checkbox"/> Addendum No. 1 | <input type="checkbox"/> Addendum No. 6 |
| <input type="checkbox"/> Addendum No. 2 | <input type="checkbox"/> Addendum No. 7 |
| <input type="checkbox"/> Addendum No. 3 | <input type="checkbox"/> Addendum No. 8 |
| <input type="checkbox"/> Addendum No. 4 | <input type="checkbox"/> Addendum No. 9 |
| <input type="checkbox"/> Addendum No. 5 | <input type="checkbox"/> Addendum No. 10 |

I understand that failure to confirm the receipt of addenda may be cause for rejection of this bid. I further understand that that any verbal representation made or assumed to be made during any oral discussion held between Vendor's representatives and any state personnel is not binding. Only the information issued in writing and added to the specifications by an official addendum is binding.

West Virginia Tractor Company

Company



Authorized Signature

2-21-20

Date

NOTE: This addendum acknowledgment should be submitted with the bid to expedite document processing.

DESIGNATED CONTACT: Vendor appoints the individual identified in this Section as the Contract Administrator and the initial point of contact for matters relating to this Contract.

 President

(Name, Title)
Gary W. Grady, President

(Printed Name and Title)
P.O. Box 473 Charleston, WV 25322

(Address)
304-346-5301 304-346-5305

(Phone Number) / (Fax Number)
wvtractor@msn.com

(email address)

CERTIFICATION AND SIGNATURE: By signing below, or submitting documentation through wvOASIS, I certify that I have reviewed this Solicitation in its entirety; that I understand the requirements, terms and conditions, and other information contained herein; that this bid, offer or proposal constitutes an offer to the State that cannot be unilaterally withdrawn; that the product or service proposed meets the mandatory requirements contained in the Solicitation for that product or service, unless otherwise stated herein; that the Vendor accepts the terms and conditions contained in the Solicitation, unless otherwise stated herein; that I am submitting this bid, offer or proposal for review and consideration; that I am authorized by the vendor to execute and submit this bid, offer, or proposal, or any documents related thereto on vendor's behalf; that I am authorized to bind the vendor in a contractual relationship; and that to the best of my knowledge, the vendor has properly registered with any State agency that may require registration.

West Virginia Tractor Company

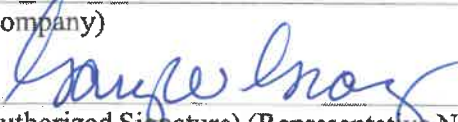
(Company)
 President

(Authorized Signature) (Representative Name, Title)
Gary W. Grady President

(Printed Name and Title of Authorized Representative)

2-21-20

(Date)

304-346-5301 304-346-5305

(Phone Number) (Fax Number)

STATE OF WEST VIRGINIA
Purchasing Division

PURCHASING AFFIDAVIT

CONSTRUCTION CONTRACTS: Under W. Va. Code § 5-22-1(i), the contracting public entity shall not award a construction contract to any bidder that is known to be in default on any monetary obligation owed to the state or a political subdivision of the state, including, but not limited to, obligations related to payroll taxes, property taxes, sales and use taxes, fire service fees, or other fines or fees.

ALL OTHER CONTRACTS: Under W. Va. Code §5A-3-10a, no contract or renewal of any contract may be awarded by the state or any of its political subdivisions to any vendor or prospective vendor when the vendor or prospective vendor or a related party to the vendor or prospective vendor is a debtor and: (1) the debt owed is an amount greater than one thousand dollars in the aggregate; or (2) the debtor is in employer default.

EXCEPTION: The prohibition listed above does not apply where a vendor has contested any tax administered pursuant to chapter eleven of the W. Va. Code, workers' compensation premium, permit fee or environmental fee or assessment and the matter has not become final or where the vendor has entered into a payment plan or agreement and the vendor is not in default of any of the provisions of such plan or agreement.

DEFINITIONS:

"Debt" means any assessment, premium, penalty, fine, tax or other amount of money owed to the state or any of its political subdivisions because of a judgment, fine, permit violation, license assessment, defaulted workers' compensation premium, penalty or other assessment presently delinquent or due and required to be paid to the state or any of its political subdivisions, including any interest or additional penalties accrued thereon.

"Employer default" means having an outstanding balance or liability to the old fund or to the uninsured employers' fund or being in policy default, as defined in W. Va. Code § 23-2c-2, failure to maintain mandatory workers' compensation coverage, or failure to fully meet its obligations as a workers' compensation self-insured employer. An employer is not in employer default if it has entered into a repayment agreement with the Insurance Commissioner and remains in compliance with the obligations under the repayment agreement.

"Related party" means a party, whether an individual, corporation, partnership, association, limited liability company or any other form or business association or other entity whatsoever, related to any vendor by blood, marriage, ownership or contract through which the party has a relationship of ownership or other interest with the vendor so that the party will actually or by effect receive or control a portion of the benefit, profit or other consideration from performance of a vendor contract with the party receiving an amount that meets or exceed five percent of the total contract amount.

AFFIRMATION: By signing this form, the vendor's authorized signer affirms and acknowledges under penalty of law for false swearing (W. Va. Code §61-5-3) that: (1) for construction contracts, the vendor is not in default on any monetary obligation owed to the state or a political subdivision of the state, and (2) for all other contracts, that neither vendor nor any related party owe a debt as defined above and that neither vendor nor any related party are in employer default as defined above, unless the debt or employer default is permitted under the exception above.

WITNESS THE FOLLOWING SIGNATURE:

Vendor's Name: West Virginia Tractor Company

Authorized Signature: *George Knoff* Date: 2-21-20

State of West Virginia

County of Kanawha, to-wit:

Taken, subscribed, and sworn to before me this 21 day of February, 2020

My Commission expires August 12, 2022

AFFIX SEAL HERE

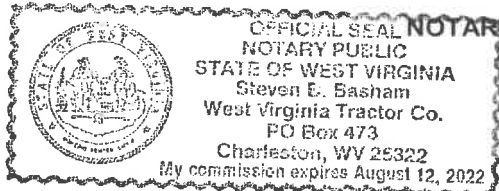

Steven B. Basham

State of West Virginia

VENDOR PREFERENCE CERTIFICATE

Certification and application is hereby made for Preference in accordance with **West Virginia Code**, §5A-3-37. (Does not apply to construction contracts). **West Virginia Code**, §5A-3-37, provides an opportunity for qualifying vendors to request (at the time of bid) preference for their residency status. Such preference is an evaluation method only and will be applied only to the cost bid in accordance with the **West Virginia Code**. This certificate for application is to be used to request such preference. The Purchasing Division will make the determination of the Vendor Preference, if applicable.

1. **Application is made for 2.5% vendor preference for the reason checked:**
 Bidder is an individual resident vendor and has resided continuously in West Virginia, or bidder is a partnership, association or corporation resident vendor and has maintained its headquarters or principal place of business continuously in West Virginia, for four (4) years immediately preceding the date of this certification; or,
 Bidder is a resident vendor partnership, association, or corporation with at least eighty percent of ownership interest of bidder held by another entity that meets the applicable four year residency requirement; or,
 Bidder is a nonresident vendor which has an affiliate or subsidiary which employs a minimum of one hundred state residents and which has maintained its headquarters or principal place of business within West Virginia continuously for the four (4) years immediately preceding the date of this certification; or,
2. **Application is made for 2.5% vendor preference for the reason checked:**
 Bidder is a resident vendor who certifies that, during the life of the contract, on average at least 75% of the employees working on the project being bid are residents of West Virginia who have resided in the state continuously for the two years immediately preceding submission of this bid; or,
3. **Application is made for 2.5% vendor preference for the reason checked:**
 Bidder is a nonresident vendor that employs a minimum of one hundred state residents, or a nonresident vendor which has an affiliate or subsidiary which maintains its headquarters or principal place of business within West Virginia and employs a minimum of one hundred state residents, and for purposes of producing or distributing the commodities or completing the project which is the subject of the bidder's bid and continuously over the entire term of the project, on average at least seventy-five percent of the bidder's employees or the bidder's affiliate's or subsidiary's employees are residents of West Virginia who have resided in the state continuously for the two immediately preceding years and the vendor's bid; or,
4. **Application is made for 5% vendor preference for the reason checked:**
 Bidder meets either the requirement of both subdivisions (1) and (2) or subdivision (1) and (3) as stated above; or,
5. **Application is made for 3.5% vendor preference who is a veteran for the reason checked:**
 Bidder is an individual resident vendor who is a veteran of the United States armed forces, the reserves or the National Guard and has resided in West Virginia continuously for the four years immediately preceding the date on which the bid is submitted; or,
6. **Application is made for 3.5% vendor preference who is a veteran for the reason checked:**
 Bidder is a resident vendor who is a veteran of the United States armed forces, the reserves or the National Guard, if, for purposes of producing or distributing the commodities or completing the project which is the subject of the vendor's bid and continuously over the entire term of the project, on average at least seventy-five percent of the vendor's employees are residents of West Virginia who have resided in the state continuously for the two immediately preceding years.
7. **Application is made for preference as a non-resident small, women- and minority-owned business, in accordance with West Virginia Code §5A-3-59 and West Virginia Code of State Rules.**
 Bidder has been or expects to be approved prior to contract award by the Purchasing Division as a certified small, women- and minority-owned business.
8. **Application is made for reciprocal preference.**
 Bidder is a West Virginia resident and is requesting reciprocal preference to the extent that it applies.

Bidder understands if the Secretary of Revenue determines that a Bidder receiving preference has failed to continue to meet the requirements for such preference, the Secretary may order the Director of Purchasing to: (a) rescind the contract or purchase order; or (b) assess a penalty against such Bidder in an amount not to exceed 5% of the bid amount and that such penalty will be paid to the contracting agency or deducted from any unpaid balance on the contract or purchase order.

By submission of this certificate, Bidder agrees to disclose any reasonably requested information to the Purchasing Division and authorizes the Department of Revenue to disclose to the Director of Purchasing appropriate information verifying that Bidder has paid the required business taxes, provided that such information does not contain the amounts of taxes paid nor any other information deemed by the Tax Commissioner to be confidential.

Bidder hereby certifies that this certificate is true and accurate in all respects; and that if a contract is issued to Bidder and if anything contained within this certificate changes during the term of the contract, Bidder will notify the Purchasing Division in writing immediately.

Bidder: West Virginia Tractor Company Signed: 
Date: 2-21-20 Title: President

*Check any combination of preference consideration(s) indicated above, which you are entitled to receive.

EXHIBIT A

CRFQ 0603 ADJ20*11- Semi-Trailer Mover / Trailer Dolly

PRICING PAGE

CONTRACT ITEM NO.	DESCRIPTION	QTY	UNIT PRICE	TOTAL
Item No. 3.1.1	Semi-Trailer Mover / Trailer Dolly	1	\$37,790	\$37,790
	DJ Products			
	Trailer Caddy HD 30K			
	Unit prices to be inclusive of all freight/delivery costs		GRAND TOTAL	\$37,790

Bidder / Vendor Information:

Name: West Virginia Tractor Company

Address: P.O. Box 473
Charleston, WV 25322

Phone: 304-346-5301
Fax: 304-346-5305

E-mail Address: wvtractor@msn.com

Authorized Signature:

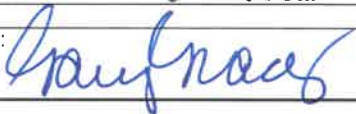

Date: 2-21-20

Please note that the 30K version of the Trailer Caddy HD is a new model and literature is not available.

We have included literature for the 23K version for illustrative purposes.

TrailerCaddy™

Terminal Tractor / 23K Lift - 48v

The TrailerCaddy Terminal Tractor is always available for moving trailers around docks and in the yard

• Relocate Trailers Just in Time •

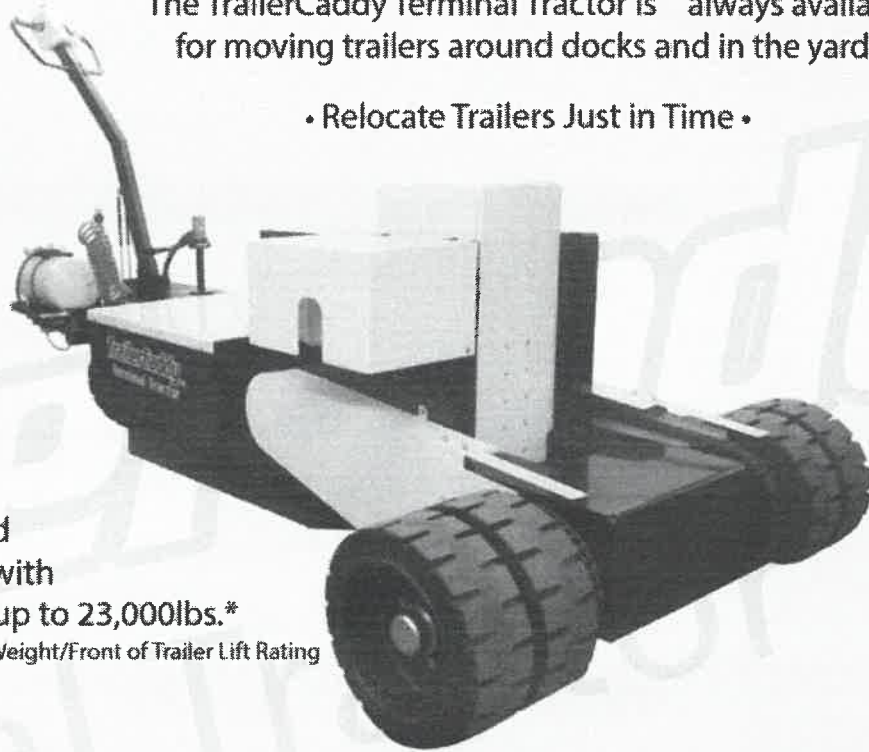

Move Empty and Loaded Trailers with Tongue Weight up to 23,000lbs.*

*Max Kingpin/Tongue Weight/Front of Trailer Lift Rating

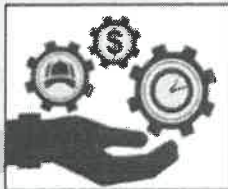

Improve Efficiency:
No CDL required. No logging driving hours. Any dock worker can move trailers at a moment's notice.

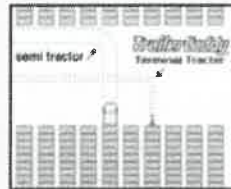

Improve Control:
Smaller and more maneuverable than a Yard Truck. Shift trailers in tight docks/yards.



Improve Safety:
Forward facing operation, better sight lines, precise steering and improved control when backing into the dock.



Low Cost:
Less than one-quarter the cost of a new shunt truck. No costly shunt truck driver. Eliminate expensive diesel maintenance.

DJ PRODUCTS . INC.

1009 4th St. NW, Little Falls, MN 56345 • PH: 800-686-2651 • FAX: 320-632-3553 • www.djproducts.com

NOT THE MODEL BEING BID - 30K
FOR ILLUSTRATIVE PURPOSES ONLY

TrailerCaddy™

Terminal Tractor / 23K Lift - 48v

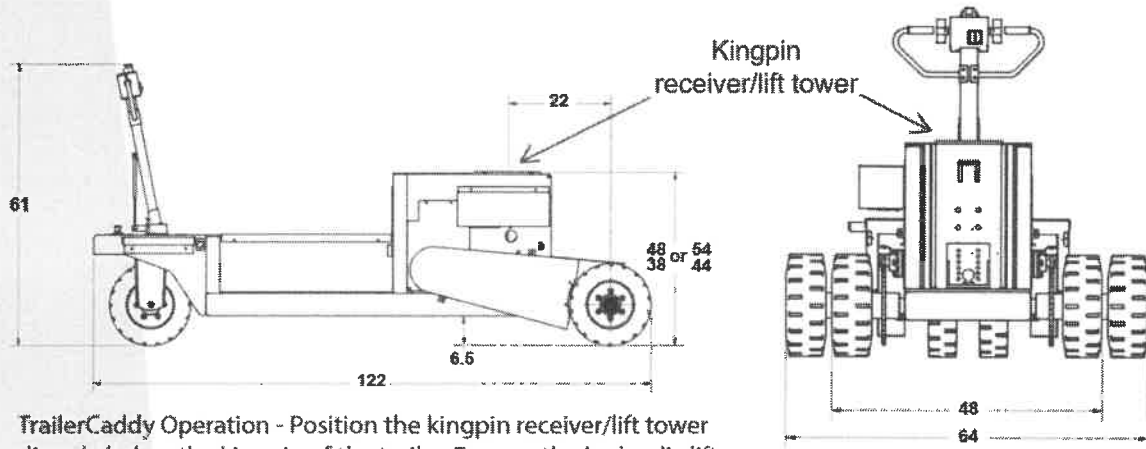

TrailerCaddy Operation - Position the kingpin receiver/lift tower directly below the kingpin of the trailer. Engage the hydraulic lift to raise the front end of the trailer off the ground. Press butterfly throttle control forward or backward to move trailer.

TrailerCaddy Terminal Tractor Standard Features

- Heavy Duty Steel Frame
- 6 HP Motor / Differential Transaxle
- 5.6:1 Gear Reduction with Chain to Drive Tires
- AC Digital Controller
- Neutral Throttle Braking
- Adjustable Acceleration/Braking
- 10" Hydraulic Pump Lift Kit
- 48v (4) 150 Amp/hr Batteries
- Variable Speed Thumb Twist Pad
- 0-1.30 mph Variable Forward/ Reverse
- Battery Discharge Indicator
- External Charger
- Safety Stop Switch
- Safety Horn
- Safety Strobe Flashing Light
- (4) 18" Solid Tread Drive Tires
- (2) 18" Solid Tread Steer Tires
- HD King Pin Receiver for 5th Wheel Trailer

TrailerCaddy Terminal Tractor Pricing and Options

TrailerCaddyTT 48V	\$33,995
Pintle Hitch	\$ 295
Ball Hitch and Bracket	\$ 125
Air Brake Release Kit With E-Stop Dumping <small>(includes pump, Glad Hand cables & 5 Gal. airtank, e-stop dump parking air brake system)</small>	\$ 1,895
King Pin Lighting Kit	\$ 140
Foot Path Lighting Kit	\$ 525
Upgrade to Qty: (8) 150 Amp Batteries	\$ 1,695
Upgrade to Qty: (8) 110 Amp AGM Batteries <small>(AGM batteries needed for overseas shipments)</small>	\$ 2,395
Upgrade to Qty: (16) 150 Amp Batteries	\$ Call
Upgrade to Qty: (16) 110 Amp AGM Batteries <small>(AGM batteries needed for overseas shipments)</small>	\$ Call

These options are only recommendations. Please consult a Sales Engineer at DJ Products, Inc. for your specific application. Other options are available.

DJ PRODUCTS, INC.

1009 4th St. NW, Little Falls, MN 56345 PH: 800-686-2651 • FAX: 320-632-3553

www.djproducts.com