



The following documentation is an electronically-submitted vendor response to an advertised solicitation from the *West Virginia Purchasing Bulletin* within the Vendor Self-Service portal at wvOASIS.gov. As part of the State of West Virginia's procurement process, and to maintain the transparency of the bid-opening process, this documentation submitted online is publicly posted by the West Virginia Purchasing Division at WVPurchasing.gov with any other vendor responses to this solicitation submitted to the Purchasing Division in hard copy format.

Header 1

[List View](#)

General Information

Contact

Default Values

Discount

Document Information

Procurement Folder: 638670

SO Doc Code: CRFQ

Procurement Type: Central Master Agreement

SO Dept: 0439

Vendor ID: VS0000002427 

SO Doc ID: EBA200000010

Legal Name: Technology International Inc

Published Date: 10/2/19

Alias/DBA:

Close Date: 10/16/19

Total Bid: \$17,436.00

Close Time: 13:30

Response Date: 10/15/2019 

Status: Closed

Response Time: 12:57

Solicitation Description: AUTMATIC AIR DEHYDRATOR
OPEN END CONTRACT

Total of Header Attachments: 1

Total of All Attachments: 1



Purchasing Division
 2019 Washington Street East
 Post Office Box 50130
 Charleston, WV 25305-0130

**State of West Virginia
 Solicitation Response**

Proc Folder : 638670

Solicitation Description : AUTMATIC AIR DEHYDRATOR OPEN END CONTRACT

Proc Type : Central Master Agreement

Date issued	Solicitation Closes	Solicitation Response	Version
	2019-10-16 13:30:00	SR 0439 ESR10151900000002419	1

VENDOR
VS0000002427 Technology International Inc

Solicitation Number: CRFQ 0439 EBA2000000010

Total Bid : \$17,436.00 **Response Date:** 2019-10-15 **Response Time:** 12:57:57

Comments:

FOR INFORMATION CONTACT THE BUYER
 Stephanie L Gale
 (304) 558-8801
 stephanie.l.gale@wv.gov

Signature on File	FEIN #	DATE
--------------------------	---------------	-------------

All offers subject to all terms and conditions contained in this solicitation

Line	Comm Ln Desc	Qty	Unit Issue	Unit Price	Ln Total Or Contract Amount
1	AUTOMATIC AIR DEHYDRATORS	4.00000	EA	\$4,359.000000	\$17,436.00

Comm Code	Manufacturer	Specification	Model #
41104208			

Extended Description :	AUTOMATIC AIR DEHYDRATORS
-------------------------------	---------------------------



Purchasing Division
 2019 Washington Street East
 Post Office Box 50130
 Charleston, WV 25305-0130

State of West Virginia
 Request for Quotation
 27 — Miscellaneous

Proc Folder: 638670

Doc Description: AUTMATIC AIR DEHYDRATOR OPEN END CONTRACT

Proc Type: Central Master Agreement

Date Issued	Solicitation Closes	Solicitation No	Version
2019-10-02	2019-10-16 13:30:00	CRFQ 0439 EBA2000000010	1

BID RECEIVING LOCATION

BID CLERK
 DEPARTMENT OF ADMINISTRATION
 PURCHASING DIVISION
 2019 WASHINGTON ST E
 CHARLESTON WV 25305
 US

VENDOR

Vendor Name, Address and Telephone Number:
[Technology International, Inc.](#)
[1349 South International Pkwy, Suite 2411,](#)
[Lake Mary, Florida 32746](#)

FOR INFORMATION CONTACT THE BUYER

Stephanie L Gale
 (304) 558-8801
 stephanie.l.gale@wv.gov

Signature X  Rifat Habib, Business Development Exec. FEIN # 650342335

DATE 10/11/2019

All offers subject to all terms and conditions contained in this solicitation

ADDITIONAL INFORMATION:

The West Virginia Purchasing Division is soliciting bids on behalf of the West Virginia Educational Broadcasting Authority, an agency of the State of West Virginia, to establish a contract for the one-time purchase of Automatic Air Dehydrators.

INVOICE TO		SHIP TO	
CHIEF FINANCIAL OFFICER EDUCATIONAL BROADCASTING 124 INDUSTRIAL PARK RD		PURCHASING ADMINISTRATOR EDUCATIONAL BROADCASTING 600 CAPITOL ST	
BEAVER	WV25813	CHARLESTON	WV 25301-1223
US		US	

Line	Comm Ln Desc	Qty	Unit Issue	Unit Price	Total Price
1	AUTOMATIC AIR DEHYDRATORS	4.00000	EA	\$4,359.00	\$17,436.00

Comm Code	Manufacturer	Specification	Model #
41104208	Viking Satcom	ADH NETCOM Automatic Dehydrator, AC	ETI-23437

Extended Description :
AUTOMATIC AIR DEHYDRATORS

***Please see our Equipment Proposal TII/WV/1019/12525 attached.

EBA2000000010	Document Phase Final	Document Description AUTMATIC AIR DEHYDRATOR OPEN END CONTRACT	Page 3 of 3
----------------------	--------------------------------	---	------------------------------

ADDITIONAL TERMS AND CONDITIONS

See attached document(s) for additional Terms and Conditions

INSTRUCTIONS TO VENDORS SUBMITTING BIDS

1. REVIEW DOCUMENTS THOROUGHLY: The attached documents contain a solicitation for bids. Please read these instructions and all documents attached in their entirety. These instructions provide critical information about requirements that if overlooked could lead to disqualification of a Vendor's bid. All bids must be submitted in accordance with the provisions contained in these instructions and the Solicitation. Failure to do so may result in disqualification of Vendor's bid.

2. MANDATORY TERMS: The Solicitation may contain mandatory provisions identified by the use of the words "must," "will," and "shall." Failure to comply with a mandatory term in the Solicitation will result in bid disqualification.

3. PREBID MEETING: The item identified below shall apply to this Solicitation.

A pre-bid meeting will not be held prior to bid opening

A NON-MANDATORY PRE-BID meeting will be held at the following place and time:

A MANDATORY PRE-BID meeting will be held at the following place and time:

All Vendors submitting a bid must attend the mandatory pre-bid meeting. Failure to attend the mandatory pre-bid meeting shall result in disqualification of the Vendor's bid. No one person attending the pre-bid meeting may represent more than one Vendor.

An attendance sheet provided at the pre-bid meeting shall serve as the official document verifying attendance. The State will not accept any other form of proof or documentation to verify attendance. Any person attending the pre-bid meeting on behalf of a Vendor must list on the attendance sheet his or her name and the name of the Vendor he or she is representing.

Additionally, the person attending the pre-bid meeting should include the Vendor's E-Mail address, phone number, and Fax number on the attendance sheet. It is the Vendor's responsibility to locate the attendance sheet and provide the required information. Failure to complete the attendance sheet as required may result in disqualification of Vendor's bid.

All Vendors should arrive prior to the starting time for the pre-bid. Vendors who arrive after the starting time but prior to the end of the pre-bid will be permitted to sign in, but are charged with knowing all matters discussed at the pre-bid.

Questions submitted at least five business days prior to a scheduled pre-bid will be discussed at the pre-bid meeting if possible. Any discussions or answers to questions at the pre-bid meeting are preliminary in nature and are non-binding. Official and binding answers to questions will be published in a written addendum to the Solicitation prior to bid opening.

4. VENDOR QUESTION DEADLINE: Vendors may submit questions relating to this Solicitation to the Purchasing Division. Questions must be submitted in writing. All questions must be submitted on or before the date listed below and to the address listed below in order to be considered. A written response will be published in a Solicitation addendum if a response is possible and appropriate. Non-written discussions, conversations, or questions and answers regarding this Solicitation are preliminary in nature and are nonbinding.

Submitted e-mails should have solicitation number in the subject line.

Question Submission Deadline: **October 9, 2019 @ 10:100am**

Submit Questions to: **Stephanie Gale**
2019 Washington Street, East
Charleston, WV 25305
Fax: (304) 558-4115 (Vendors should not use this fax number for bid submission)
Email: **Stephanie.L.Gale@wv.gov**

5. VERBAL COMMUNICATION: Any verbal communication between the Vendor and any State personnel is not binding, including verbal communication at the mandatory pre-bid conference. Only information issued in writing and added to the Solicitation by an official written addendum by the Purchasing Division is binding.

6. BID SUBMISSION: All bids must be submitted electronically through wvOASIS or signed and delivered by the Vendor to the Purchasing Division at the address listed below on or before the date and time of the bid opening. Any bid received by the Purchasing Division staff is considered to be in the possession of the Purchasing Division and will not be returned for any reason. The Purchasing Division will not accept bids, modification of bids, or addendum acknowledgment forms via e-mail. Acceptable delivery methods include electronic submission via wvOASIS, hand delivery, delivery by courier, or facsimile.

The bid delivery address is:
Department of Administration, Purchasing Division
2019 Washington Street East
Charleston, WV 25305-0130

A bid that is not submitted electronically through wvOASIS should contain the information listed below on the face of the envelope or the bid may be rejected by the Purchasing Division.:

SEALED BID:
BUYER:
SOLICITATION NO.:
BID OPENING DATE:
BID OPENING TIME:
FAX NUMBER:

The Purchasing Division may prohibit the submission of bids electronically through wvOASIS at its sole discretion. Such a prohibition will be contained and communicated in the wvOASIS system resulting in the Vendor's inability to submit bids through wvOASIS. Submission of a response to an Expression or Interest or Request for Proposal is not permitted in wvOASIS.

For Request For Proposal ("RFP") Responses Only: In the event that Vendor is responding to a request for proposal, the Vendor shall submit one original technical and one original cost proposal plus _____ convenience copies of each to the Purchasing Division at the address shown above. Additionally, the Vendor should identify the bid type as either a technical or cost proposal on the face of each bid envelope submitted in response to a request for proposal as follows:

BID TYPE: (This only applies to CRFP)

- Technical
 Cost

7. BID OPENING: Bids submitted in response to this Solicitation will be opened at the location identified below on the date and time listed below. Delivery of a bid after the bid opening date and time will result in bid disqualification. For purposes of this Solicitation, a bid is considered delivered when confirmation of delivery is provided by wvOASIS (in the case of electronic submission) or when the bid is time stamped by the official Purchasing Division time clock (in the case of hand delivery).

Bid Opening Date and Time: **October 16, 2019 @ 1:30pm**

Bid Opening Location: Department of Administration, Purchasing Division
2019 Washington Street East
Charleston, WV 25305-0130

8. ADDENDUM ACKNOWLEDGEMENT: Changes or revisions to this Solicitation will be made by an official written addendum issued by the Purchasing Division. Vendor should acknowledge receipt of all addenda issued with this Solicitation by completing an Addendum Acknowledgment Form, a copy of which is included herewith. Failure to acknowledge addenda may result in bid disqualification. The addendum acknowledgement should be submitted with the bid to expedite document processing.

9. BID FORMATTING: Vendor should type or electronically enter the information onto its bid to prevent errors in the evaluation. Failure to type or electronically enter the information may result in bid disqualification.

10. ALTERNATE MODEL OR BRAND: Unless the box below is checked, any model, brand, or specification listed in this Solicitation establishes the acceptable level of quality only and is not intended to reflect a preference for, or in any way favor, a particular brand or vendor. Vendors may bid alternates to a listed model or brand provided that the alternate is at least equal to the model or brand and complies with the required specifications. The equality of any alternate being bid shall be determined by the State at its sole discretion. Any Vendor bidding an alternate model or brand should clearly identify the alternate items in its bid and should include manufacturer's specifications, industry literature, and/or any other relevant documentation demonstrating the equality of the alternate items. Failure to provide information for alternate items may be grounds for rejection of a Vendor's bid.

This Solicitation is based upon a standardized commodity established under W. Va. Code § 5A-3-61. Vendors are expected to bid the standardized commodity identified. Failure to bid the standardized commodity will result in your firm's bid being rejected.

11. EXCEPTIONS AND CLARIFICATIONS: The Solicitation contains the specifications that shall form the basis of a contractual agreement. Vendor shall clearly mark any exceptions, clarifications, or other proposed modifications in its bid. Exceptions to, clarifications of, or modifications of a requirement or term and condition of the Solicitation may result in bid disqualification.

12. COMMUNICATION LIMITATIONS: In accordance with West Virginia Code of State Rules §148-1-6.6, communication with the State of West Virginia or any of its employees regarding this Solicitation during the solicitation, bid, evaluation or award periods, except through the Purchasing Division, is strictly prohibited without prior Purchasing Division approval. Purchasing Division approval for such communication is implied for all agency delegated and exempt purchases.

13. REGISTRATION: Prior to Contract award, the apparent successful Vendor must be properly registered with the West Virginia Purchasing Division and must have paid the \$125 fee, if applicable.

14. UNIT PRICE: Unit prices shall prevail in cases of a discrepancy in the Vendor's bid.

15. PREFERENCE: Vendor Preference may be requested in purchases of motor vehicles or construction and maintenance equipment and machinery used in highway and other infrastructure projects. Any request for preference must be submitted in writing with the bid, must specifically identify the preference requested with reference to the applicable subsection of West Virginia Code § 5A-3-37, and should include with the bid any information necessary to evaluate and confirm the applicability of the requested preference. A request form to help facilitate the request can be found at:

<http://www.state.wv.us/admin/purchase/vrc/Venpref.pdf>.

15A. RECIPROCAL PREFERENCE: The State of West Virginia applies a reciprocal preference to all solicitations for commodities and printing in accordance with W. Va. Code § 5A-3-37(b). In effect, non-resident vendors receiving a preference in their home states, will see that same preference granted to West Virginia resident vendors bidding against them in West Virginia. A request form to help facilitate the request can be found at:

<http://www.state.wv.us/admin/purchase/vrc/Venpref.pdf>.

16. SMALL, WOMEN-OWNED, OR MINORITY-OWNED BUSINESSES: For any solicitations publicly advertised for bid, in accordance with West Virginia Code §5A-3-37(a)(7) and W. Va. CSR § 148-22-9, any non-resident vendor certified as a small, women-owned, or minority-owned business under W. Va. CSR § 148-22-9 shall be provided the same preference made available to any resident vendor. Any non-resident small, women-owned, or minority-owned business must identify itself as such in writing, must submit that writing to the Purchasing Division with its bid, and must be properly certified under W. Va. CSR § 148-22-9 prior to contract award to receive the preferences made available to resident vendors. Preference for a non-resident small, women-owned, or minority owned business shall be applied in accordance with W. Va. CSR § 148-22-9.

17. WAIVER OF MINOR IRREGULARITIES: The Director reserves the right to waive minor irregularities in bids or specifications in accordance with West Virginia Code of State Rules § 148-1-4.6.

18. ELECTRONIC FILE ACCESS RESTRICTIONS: Vendor must ensure that its submission in wvOASIS can be accessed and viewed by the Purchasing Division staff immediately upon bid opening. The Purchasing Division will consider any file that cannot be immediately accessed and viewed at the time of the bid opening (such as, encrypted files, password protected files, or incompatible files) to be blank or incomplete as context requires, and are therefore unacceptable. A vendor will not be permitted to unencrypt files, remove password protections, or resubmit documents after bid opening to make a file viewable if those documents are required with the bid. A Vendor may be required to provide document passwords or remove access restrictions to allow the Purchasing Division to print or electronically save documents provided that those documents are viewable by the Purchasing Division prior to obtaining the password or removing the access restriction.

19. NON-RESPONSIBLE: The Purchasing Division Director reserves the right to reject the bid of any vendor as Non-Responsible in accordance with W. Va. Code of State Rules § 148-1-5.3, when the Director determines that the vendor submitting the bid does not have the capability to fully perform, or lacks the integrity and reliability to assure good-faith performance.”

20. ACCEPTANCE/REJECTION: The State may accept or reject any bid in whole, or in part in accordance with W. Va. Code of State Rules § 148-1-4.5. and § 148-1-6.4.b.”

21. YOUR SUBMISSION IS A PUBLIC DOCUMENT: Vendor’s entire response to the Solicitation and the resulting Contract are public documents. As public documents, they will be disclosed to the public following the bid/proposal opening or award of the contract, as required by the competitive bidding laws of West Virginia Code §§ 5A-3-1 et seq., 5-22-1 et seq., and 5G-1-1 et seq. and the Freedom of Information Act West Virginia Code §§ 29B-1-1 et seq.

DO NOT SUBMIT MATERIAL YOU CONSIDER TO BE CONFIDENTIAL, A TRADE SECRET, OR OTHERWISE NOT SUBJECT TO PUBLIC DISCLOSURE.

Submission of any bid, proposal, or other document to the Purchasing Division constitutes your explicit consent to the subsequent public disclosure of the bid, proposal, or document. The Purchasing Division will disclose any document labeled “confidential,” “proprietary,” “trade secret,” “private,” or labeled with any other claim against public disclosure of the documents, to include any “trade secrets” as defined by West Virginia Code § 47-22-1 et seq. All submissions are subject to public disclosure without notice.

22. INTERESTED PARTY DISCLOSURE: West Virginia Code § 6D-1-2 requires that the vendor submit to the Purchasing Division a disclosure of interested parties to the contract for all contracts with an actual or estimated value of at least \$1 Million. That disclosure must occur on the form prescribed and approved by the WV Ethics Commission prior to contract award. A copy of that form is included with this solicitation or can be obtained from the WV Ethics Commission. This requirement does not apply to publicly traded companies listed on a national or international stock exchange. A more detailed definition of interested parties can be obtained from the form referenced above.

23. WITH THE BID REQUIREMENTS: In instances where these specifications require documentation or other information with the bid, and a vendor fails to provide it with the bid, the Director of the Purchasing Division reserves the right to request those items after bid opening and prior to contract award pursuant to the authority to waive minor irregularities in bids or specifications under W. Va. CSR § 148-1-4.6. This authority does not apply to instances where state law mandates receipt with the bid.

GENERAL TERMS AND CONDITIONS:

1. CONTRACTUAL AGREEMENT: Issuance of a Award Document signed by the Purchasing Division Director, or his designee, and approved as to form by the Attorney General's office constitutes acceptance of this Contract made by and between the State of West Virginia and the Vendor. Vendor's signature on its bid signifies Vendor's agreement to be bound by and accept the terms and conditions contained in this Contract.

2. DEFINITIONS: As used in this Solicitation/Contract, the following terms shall have the meanings attributed to them below. Additional definitions may be found in the specifications included with this Solicitation/Contract.

2.1. "Agency" or "Agencies" means the agency, board, commission, or other entity of the State of West Virginia that is identified on the first page of the Solicitation or any other public entity seeking to procure goods or services under this Contract.

2.2. "Bid" or "Proposal" means the vendors submitted response to this solicitation.

2.3. "Contract" means the binding agreement that is entered into between the State and the Vendor to provide the goods or services requested in the Solicitation.

2.4. "Director" means the Director of the West Virginia Department of Administration, Purchasing Division.

2.5. "Purchasing Division" means the West Virginia Department of Administration, Purchasing Division.

2.6. "Award Document" means the document signed by the Agency and the Purchasing Division, and approved as to form by the Attorney General, that identifies the Vendor as the contract holder.

2.7. "Solicitation" means the official notice of an opportunity to supply the State with goods or services that is published by the Purchasing Division.

2.8. "State" means the State of West Virginia and/or any of its agencies, commissions, boards, etc. as context requires.

2.9. "Vendor" or "Vendors" means any entity submitting a bid in response to the Solicitation, the entity that has been selected as the lowest responsible bidder, or the entity that has been awarded the Contract as context requires.

3. CONTRACT TERM; RENEWAL; EXTENSION: The term of this Contract shall be determined in accordance with the category that has been identified as applicable to this Contract below:

Term Contract

Initial Contract Term: **Initial Contract Term:** This Contract becomes effective on upon award and extends for a period of one year(s).

Renewal Term: This Contract may be renewed upon the mutual written consent of the Agency, and the Vendor, with approval of the Purchasing Division and the Attorney General's office (Attorney General approval is as to form only). Any request for renewal should be delivered to the Agency and then submitted to the Purchasing Division thirty (30) days prior to the expiration date of the initial contract term or appropriate renewal term. A Contract renewal shall be in accordance with the terms and conditions of the original contract. Unless otherwise specified below, renewal of this Contract is limited to two successive one (1) year periods or multiple renewal periods of less than one year, provided that the multiple renewal periods do not exceed the total number of months available in all renewal years combined. Automatic renewal of this Contract is prohibited. Renewals must be approved by the Vendor, Agency, Purchasing Division and Attorney General's office (Attorney General approval is as to form only)

Alternate Renewal Term – This contract may be renewed for successive year periods or shorter periods provided that they do not exceed the total number of months contained in all available renewals. Automatic renewal of this Contract is prohibited. Renewals must be approved by the Vendor, Agency, Purchasing Division and Attorney General's office (Attorney General approval is as to form only)

Delivery Order Limitations: In the event that this contract permits delivery orders, a delivery order may only be issued during the time this Contract is in effect. Any delivery order issued within one year of the expiration of this Contract shall be effective for one year from the date the delivery order is issued. No delivery order may be extended beyond one year after this Contract has expired.

Fixed Period Contract: This Contract becomes effective upon Vendor's receipt of the notice to proceed and must be completed within days.

Fixed Period Contract with Renewals: This Contract becomes effective upon Vendor's receipt of the notice to proceed and part of the Contract more fully described in the attached specifications must be completed within days. Upon completion of the work covered by the preceding sentence, the vendor agrees that maintenance, monitoring, or warranty services will be provided for year(s) thereafter.

One Time Purchase: The term of this Contract shall run from the issuance of the Award Document until all of the goods contracted for have been delivered, but in no event will this Contract extend for more than one fiscal year.

Other: See attached.

4. NOTICE TO PROCEED: Vendor shall begin performance of this Contract immediately upon receiving notice to proceed unless otherwise instructed by the Agency. Unless otherwise specified, the fully executed Award Document will be considered notice to proceed.

5. QUANTITIES: The quantities required under this Contract shall be determined in accordance with the category that has been identified as applicable to this Contract below.

Open End Contract: Quantities listed in this Solicitation are approximations only, based on estimates supplied by the Agency. It is understood and agreed that the Contract shall cover the quantities actually ordered for delivery during the term of the Contract, whether more or less than the quantities shown.

Service: The scope of the service to be provided will be more clearly defined in the specifications included herewith.

Combined Service and Goods: The scope of the service and deliverable goods to be provided will be more clearly defined in the specifications included herewith.

One Time Purchase: This Contract is for the purchase of a set quantity of goods that are identified in the specifications included herewith. Once those items have been delivered, no additional goods may be procured under this Contract without an appropriate change order approved by the Vendor, Agency, Purchasing Division, and Attorney General's office.

6. EMERGENCY PURCHASES: The Purchasing Division Director may authorize the Agency to purchase goods or services in the open market that Vendor would otherwise provide under this Contract if those goods or services are for immediate or expedited delivery in an emergency. Emergencies shall include, but are not limited to, delays in transportation or an unanticipated increase in the volume of work. An emergency purchase in the open market, approved by the Purchasing Division Director, shall not constitute a breach of this Contract and shall not entitle the Vendor to any form of compensation or damages. This provision does not excuse the State from fulfilling its obligations under a One Time Purchase contract.

7. REQUIRED DOCUMENTS: All of the items checked below must be provided to the Purchasing Division by the Vendor as specified below.

BID BOND (Construction Only): Pursuant to the requirements contained in W. Va. Code § 5-22-1(c), All Vendors submitting a bid on a construction project shall furnish a valid bid bond in the amount of five percent (5%) of the total amount of the bid protecting the State of West Virginia. The bid bond must be submitted with the bid.

PERFORMANCE BOND: The apparent successful Vendor shall provide a performance bond in the amount of 100% of the contract. The performance bond must be received by the Purchasing Division prior to Contract award.

LABOR/MATERIAL PAYMENT BOND: The apparent successful Vendor shall provide a labor/material payment bond in the amount of 100% of the Contract value. The labor/material payment bond must be delivered to the Purchasing Division prior to Contract award.

In lieu of the Bid Bond, Performance Bond, and Labor/Material Payment Bond, the Vendor may provide certified checks, cashier's checks, or irrevocable letters of credit. Any certified check, cashier's check, or irrevocable letter of credit provided in lieu of a bond must be of the same amount and delivered on the same schedule as the bond it replaces. A letter of credit submitted in lieu of a performance and labor/material payment bond will only be allowed for projects under \$100,000. Personal or business checks are not acceptable. Notwithstanding the foregoing, West Virginia Code § 5-22-1 (d) mandates that a vendor provide a performance and labor/material payment bond for construction projects. Accordingly, substitutions for the performance and labor/material payment bonds for construction projects is not permitted.

MAINTENANCE BOND: The apparent successful Vendor shall provide a two (2) year maintenance bond covering the roofing system. The maintenance bond must be issued and delivered to the Purchasing Division prior to Contract award.

LICENSE(S) / CERTIFICATIONS / PERMITS: In addition to anything required under the Section of the General Terms and Conditions entitled Licensing, the apparent successful Vendor shall furnish proof of the following licenses, certifications, and/or permits prior to Contract award, in a form acceptable to the Purchasing Division.

The apparent successful Vendor shall also furnish proof of any additional licenses or certifications contained in the specifications prior to Contract award regardless of whether or not that requirement is listed above.

8. INSURANCE: The apparent successful Vendor shall furnish proof of the insurance identified by a checkmark below and must include the State as an additional insured on each policy prior to Contract award. The insurance coverages identified below must be maintained throughout the life of this contract. Thirty (30) days prior to the expiration of the insurance policies, Vendor shall provide the Agency with proof that the insurance mandated herein has been continued. Vendor must also provide Agency with immediate notice of any changes in its insurance policies, including but not limited to, policy cancelation, policy reduction, or change in insurers. The apparent successful Vendor shall also furnish proof of any additional insurance requirements contained in the specifications prior to Contract award regardless of whether or not that insurance requirement is listed in this section.

Vendor must maintain:

- Commercial General Liability Insurance** in at least an amount of: \$1,000,000.00 per occurrence.
- Automobile Liability Insurance** in at least an amount of: _____ per occurrence.
- Professional/Malpractice/Errors and Omission Insurance** in at least an amount of: _____ per occurrence.
- Commercial Crime and Third Party Fidelity Insurance** in an amount of: _____ per occurrence.
- Cyber Liability Insurance** in an amount of: _____ per occurrence.
- Builders Risk Insurance** in an amount equal to 100% of the amount of the Contract.
- Pollution Insurance** in an amount of: _____ per occurrence.
- Aircraft Liability** in an amount of: _____ per occurrence.
-
-
-
-

Notwithstanding anything contained in this section to the contrary, the Director of the Purchasing Division reserves the right to waive the requirement that the State be named as an additional insured on one or more of the Vendor's insurance policies if the Director finds that doing so is in the State's best interest.

9. WORKERS' COMPENSATION INSURANCE: The apparent successful Vendor shall comply with laws relating to workers compensation, shall maintain workers' compensation insurance when required, and shall furnish proof of workers' compensation insurance upon request.

10. [Reserved]

11. LIQUIDATED DAMAGES: This clause shall in no way be considered exclusive and shall not limit the State or Agency's right to pursue any other available remedy. Vendor shall pay liquidated damages in the amount specified below or as described in the specifications:

_____ for _____

Liquidated Damages Contained in the Specifications

12. ACCEPTANCE: Vendor's signature on its bid, or on the certification and signature page, constitutes an offer to the State that cannot be unilaterally withdrawn, signifies that the product or service proposed by vendor meets the mandatory requirements contained in the Solicitation for that product or service, unless otherwise indicated, and signifies acceptance of the terms and conditions contained in the Solicitation unless otherwise indicated.

13. PRICING: The pricing set forth herein is firm for the life of the Contract, unless specified elsewhere within this Solicitation/Contract by the State. A Vendor's inclusion of price adjustment provisions in its bid, without an express authorization from the State in the Solicitation to do so, may result in bid disqualification.

14. PAYMENT IN ARREARS: Payment in advance is prohibited under this Contract. Payment may only be made after the delivery and acceptance of goods or services. The Vendor shall submit invoices, in arrears.

15. PAYMENT METHODS: Vendor must accept payment by electronic funds transfer and P-Card. (The State of West Virginia's Purchasing Card program, administered under contract by a banking institution, processes payment for goods and services through state designated credit cards.)

16. TAXES: The Vendor shall pay any applicable sales, use, personal property or any other taxes arising out of this Contract and the transactions contemplated thereby. The State of West Virginia is exempt from federal and state taxes and will not pay or reimburse such taxes.

17. ADDITIONAL FEES: Vendor is not permitted to charge additional fees or assess additional charges that were not either expressly provided for in the solicitation published by the State of West Virginia or included in the unit price or lump sum bid amount that Vendor is required by the solicitation to provide. Including such fees or charges as notes to the solicitation may result in rejection of vendor's bid. Requesting such fees or charges be paid after the contract has been awarded may result in cancellation of the contract.

18. FUNDING: This Contract shall continue for the term stated herein, contingent upon funds being appropriated by the Legislature or otherwise being made available. In the event funds are not appropriated or otherwise made available, this Contract becomes void and of no effect beginning on July 1 of the fiscal year for which funding has not been appropriated or otherwise made available.

19. CANCELLATION: The Purchasing Division Director reserves the right to cancel this Contract immediately upon written notice to the vendor if the materials or workmanship supplied do not conform to the specifications contained in the Contract. The Purchasing Division Director may also cancel any purchase or Contract upon 30 days written notice to the Vendor in accordance with West Virginia Code of State Rules § 148-1-5.2.b.

20. TIME: Time is of the essence with regard to all matters of time and performance in this Contract.

21. APPLICABLE LAW: This Contract is governed by and interpreted under West Virginia law without giving effect to its choice of law principles. Any information provided in specification manuals, or any other source, verbal or written, which contradicts or violates the West Virginia Constitution, West Virginia Code or West Virginia Code of State Rules is void and of no effect.

22. COMPLIANCE WITH LAWS: Vendor shall comply with all applicable federal, state, and local laws, regulations and ordinances. By submitting a bid, Vendor acknowledges that it has reviewed, understands, and will comply with all applicable laws, regulations, and ordinances.

SUBCONTRACTOR COMPLIANCE: Vendor shall notify all subcontractors providing commodities or services related to this Contract that as subcontractors, they too are required to comply with all applicable laws, regulations, and ordinances. Notification under this provision must occur prior to the performance of any work under the contract by the subcontractor.

23. ARBITRATION: Any references made to arbitration contained in this Contract, Vendor's bid, or in any American Institute of Architects documents pertaining to this Contract are hereby deleted, void, and of no effect.

24. MODIFICATIONS: This writing is the parties' final expression of intent. Notwithstanding anything contained in this Contract to the contrary no modification of this Contract shall be binding without mutual written consent of the Agency, and the Vendor, with approval of the Purchasing Division and the Attorney General's office (Attorney General approval is as to form only). Any change to existing contracts that adds work or changes contract cost, and were not included in the original contract, must be approved by the Purchasing Division and the Attorney General's Office (as to form) prior to the implementation of the change or commencement of work affected by the change.

25. WAIVER: The failure of either party to insist upon a strict performance of any of the terms or provision of this Contract, or to exercise any option, right, or remedy herein contained, shall not be construed as a waiver or a relinquishment for the future of such term, provision, option, right, or remedy, but the same shall continue in full force and effect. Any waiver must be expressly stated in writing and signed by the waiving party.

26. SUBSEQUENT FORMS: The terms and conditions contained in this Contract shall supersede any and all subsequent terms and conditions which may appear on any form documents submitted by Vendor to the Agency or Purchasing Division such as price lists, order forms, invoices, sales agreements, or maintenance agreements, and includes internet websites or other electronic documents. Acceptance or use of Vendor's forms does not constitute acceptance of the terms and conditions contained thereon.

27. ASSIGNMENT: Neither this Contract nor any monies due, or to become due hereunder, may be assigned by the Vendor without the express written consent of the Agency, the Purchasing Division, the Attorney General's office (as to form only), and any other government agency or office that may be required to approve such assignments.

28. WARRANTY: The Vendor expressly warrants that the goods and/or services covered by this Contract will: (a) conform to the specifications, drawings, samples, or other description furnished or specified by the Agency; (b) be merchantable and fit for the purpose intended; and (c) be free from defect in material and workmanship.

29. STATE EMPLOYEES: State employees are not permitted to utilize this Contract for personal use and the Vendor is prohibited from permitting or facilitating the same.

30. PRIVACY, SECURITY, AND CONFIDENTIALITY: The Vendor agrees that it will not disclose to anyone, directly or indirectly, any such personally identifiable information or other confidential information gained from the Agency, unless the individual who is the subject of the information consents to the disclosure in writing or the disclosure is made pursuant to the Agency's policies, procedures, and rules. Vendor further agrees to comply with the Confidentiality Policies and Information Security Accountability Requirements, set forth in <http://www.state.wv.us/admin/purchase/privacy/default.html>.

31. YOUR SUBMISSION IS A PUBLIC DOCUMENT: Vendor's entire response to the Solicitation and the resulting Contract are public documents. As public documents, they will be disclosed to the public following the bid/proposal opening or award of the contract, as required by the competitive bidding laws of West Virginia Code §§ 5A-3-1 et seq., 5-22-1 et seq., and 5G-1-1 et seq. and the Freedom of Information Act West Virginia Code §§ 29B-1-1 et seq.

DO NOT SUBMIT MATERIAL YOU CONSIDER TO BE CONFIDENTIAL, A TRADE SECRET, OR OTHERWISE NOT SUBJECT TO PUBLIC DISCLOSURE.

Submission of any bid, proposal, or other document to the Purchasing Division constitutes your explicit consent to the subsequent public disclosure of the bid, proposal, or document. The Purchasing Division will disclose any document labeled "confidential," "proprietary," "trade secret," "private," or labeled with any other claim against public disclosure of the documents, to include any "trade secrets" as defined by West Virginia Code § 47-22-1 et seq. All submissions are subject to public disclosure without notice.

32. LICENSING: In accordance with West Virginia Code of State Rules § 148-1-6.1.e, Vendor must be licensed and in good standing in accordance with any and all state and local laws and requirements by any state or local agency of West Virginia, including, but not limited to, the West Virginia Secretary of State's Office, the West Virginia Tax Department, West Virginia Insurance Commission, or any other state agency or political subdivision. Obligations related to political subdivisions may include, but are not limited to, business licensing, business and occupation taxes, inspection compliance, permitting, etc. Upon request, the Vendor must provide all necessary releases to obtain information to enable the Purchasing Division Director or the Agency to verify that the Vendor is licensed and in good standing with the above entities.

SUBCONTRACTOR COMPLIANCE: Vendor shall notify all subcontractors providing commodities or services related to this Contract that as subcontractors, they too are required to be licensed, in good standing, and up-to-date on all state and local obligations as described in this section. Obligations related to political subdivisions may include, but are not limited to, business licensing, business and occupation taxes, inspection compliance, permitting, etc. Notification under this provision must occur prior to the performance of any work under the contract by the subcontractor.

33. ANTITRUST: In submitting a bid to, signing a contract with, or accepting a Award Document from any agency of the State of West Virginia, the Vendor agrees to convey, sell, assign, or transfer to the State of West Virginia all rights, title, and interest in and to all causes of action it may now or hereafter acquire under the antitrust laws of the United States and the State of West Virginia for price fixing and/or unreasonable restraints of trade relating to the particular commodities or services purchased or acquired by the State of West Virginia. Such assignment shall be made and become effective at the time the purchasing agency tenders the initial payment to Vendor.

34. VENDOR CERTIFICATIONS: By signing its bid or entering into this Contract, Vendor certifies (1) that its bid or offer was made without prior understanding, agreement, or connection with any corporation, firm, limited liability company, partnership, person or entity submitting a bid or offer for the same material, supplies, equipment or services; (2) that its bid or offer is in all respects fair and without collusion or fraud; (3) that this Contract is accepted or entered into without any prior understanding, agreement, or connection to any other entity that could be considered a violation of law; and (4) that it has reviewed this Solicitation in its entirety; understands the requirements, terms and conditions, and other information contained herein.

Vendor's signature on its bid or offer also affirms that neither it nor its representatives have any interest, nor shall acquire any interest, direct or indirect, which would compromise the performance of its services hereunder. Any such interests shall be promptly presented in detail to the Agency. The individual signing this bid or offer on behalf of Vendor certifies that he or she is authorized by the Vendor to execute this bid or offer or any documents related thereto on Vendor's behalf; that he or she is authorized to bind the Vendor in a contractual relationship; and that, to the best of his or her knowledge, the Vendor has properly registered with any State agency that may require registration.

35. VENDOR RELATIONSHIP: The relationship of the Vendor to the State shall be that of an independent contractor and no principal-agent relationship or employer-employee relationship is contemplated or created by this Contract. The Vendor as an independent contractor is solely liable for the acts and omissions of its employees and agents. Vendor shall be responsible for selecting, supervising, and compensating any and all individuals employed pursuant to the terms of this Solicitation and resulting contract. Neither the Vendor, nor any employees or subcontractors of the Vendor, shall be deemed to be employees of the State for any purpose whatsoever. Vendor shall be exclusively responsible for payment of employees and contractors for all wages and salaries, taxes, withholding payments, penalties, fees, fringe benefits, professional liability insurance premiums, contributions to insurance and pension, or other deferred compensation plans, including but not limited to, Workers' Compensation and Social Security obligations, licensing fees, etc. and the filing of all necessary documents, forms, and returns pertinent to all of the foregoing.

Vendor shall hold harmless the State, and shall provide the State and Agency with a defense against any and all claims including, but not limited to, the foregoing payments, withholdings, contributions, taxes, Social Security taxes, and employer income tax returns.

36. INDEMNIFICATION: The Vendor agrees to indemnify, defend, and hold harmless the State and the Agency, their officers, and employees from and against: (1) Any claims or losses for services rendered by any subcontractor, person, or firm performing or supplying services, materials, or supplies in connection with the performance of the Contract; (2) Any claims or losses resulting to any person or entity injured or damaged by the Vendor, its officers, employees, or subcontractors by the publication, translation, reproduction, delivery, performance, use, or disposition of any data used under the Contract in a manner not authorized by the Contract, or by Federal or State statutes or regulations; and (3) Any failure of the Vendor, its officers, employees, or subcontractors to observe State and Federal laws including, but not limited to, labor and wage and hour laws.

37. PURCHASING AFFIDAVIT: In accordance with West Virginia Code §§ 5A-3-10a and 5-22-1(i), the State is prohibited from awarding a contract to any bidder that owes a debt to the State or a political subdivision of the State, Vendors are required to sign, notarize, and submit the Purchasing Affidavit to the Purchasing Division affirming under oath that it is not in default on any monetary obligation owed to the state or a political subdivision of the state.

38. ADDITIONAL AGENCY AND LOCAL GOVERNMENT USE: This Contract may be utilized by other agencies, spending units, and political subdivisions of the State of West Virginia; county, municipal, and other local government bodies; and school districts (“Other Government Entities”), provided that both the Other Government Entity and the Vendor agree. Any extension of this Contract to the aforementioned Other Government Entities must be on the same prices, terms, and conditions as those offered and agreed to in this Contract, provided that such extension is in compliance with the applicable laws, rules, and ordinances of the Other Government Entity. A refusal to extend this Contract to the Other Government Entities shall not impact or influence the award of this Contract in any manner.

39. CONFLICT OF INTEREST: Vendor, its officers or members or employees, shall not presently have or acquire an interest, direct or indirect, which would conflict with or compromise the performance of its obligations hereunder. Vendor shall periodically inquire of its officers, members and employees to ensure that a conflict of interest does not arise. Any conflict of interest discovered shall be promptly presented in detail to the Agency.

40. REPORTS: Vendor shall provide the Agency and/or the Purchasing Division with the following reports identified by a checked box below:

Such reports as the Agency and/or the Purchasing Division may request. Requested reports may include, but are not limited to, quantities purchased, agencies utilizing the contract, total contract expenditures by agency, etc.

Quarterly reports detailing the total quantity of purchases in units and dollars, along with a listing of purchases by agency. Quarterly reports should be delivered to the Purchasing Division via email at purchasing.requisitions@wv.gov.

41. BACKGROUND CHECK: In accordance with W. Va. Code § 15-2D-3, the Director of the Division of Protective Services shall require any service provider whose employees are regularly employed on the grounds or in the buildings of the Capitol complex or who have access to sensitive or critical information to submit to a fingerprint-based state and federal background inquiry through the state repository. The service provider is responsible for any costs associated with the fingerprint-based state and federal background inquiry.

After the contract for such services has been approved, but before any such employees are permitted to be on the grounds or in the buildings of the Capitol complex or have access to sensitive or critical information, the service provider shall submit a list of all persons who will be physically present and working at the Capitol complex to the Director of the Division of Protective Services for purposes of verifying compliance with this provision. The State reserves the right to prohibit a service provider’s employees from accessing sensitive or critical information or to be present at the Capitol complex based upon results addressed from a criminal background check.

Revised 06/08/2018

Service providers should contact the West Virginia Division of Protective Services by phone at (304) 558-9911 for more information.

42. PREFERENCE FOR USE OF DOMESTIC STEEL PRODUCTS: Except when authorized by the Director of the Purchasing Division pursuant to W. Va. Code § 5A-3-56, no contractor may use or supply steel products for a State Contract Project other than those steel products made in the United States. A contractor who uses steel products in violation of this section may be subject to civil penalties pursuant to W. Va. Code § 5A-3-56. As used in this section:

- a. "State Contract Project" means any erection or construction of, or any addition to, alteration of or other improvement to any building or structure, including, but not limited to, roads or highways, or the installation of any heating or cooling or ventilating plants or other equipment, or the supply of and materials for such projects, pursuant to a contract with the State of West Virginia for which bids were solicited on or after June 6, 2001.
- b. "Steel Products" means products rolled, formed, shaped, drawn, extruded, forged, cast, fabricated or otherwise similarly processed, or processed by a combination of two or more or such operations, from steel made by the open heath, basic oxygen, electric furnace, Bessemer or other steel making process. The Purchasing Division Director may, in writing, authorize the use of foreign steel products if:
- c. The cost for each contract item used does not exceed one tenth of one percent (.1%) of the total contract cost or two thousand five hundred dollars (\$2,500.00), whichever is greater. For the purposes of this section, the cost is the value of the steel product as delivered to the project; or
- d. The Director of the Purchasing Division determines that specified steel materials are not produced in the United States in sufficient quantity or otherwise are not reasonably available to meet contract requirements.

43. PREFERENCE FOR USE OF DOMESTIC ALUMINUM, GLASS, AND STEEL: In Accordance with W. Va. Code § 5-19-1 et seq., and W. Va. CSR § 148-10-1 et seq., for every contract or subcontract, subject to the limitations contained herein, for the construction, reconstruction, alteration, repair, improvement or maintenance of public works or for the purchase of any item of machinery or equipment to be used at sites of public works, only domestic aluminum, glass or steel products shall be supplied unless the spending officer determines, in writing, after the receipt of offers or bids, (1) that the cost of domestic aluminum, glass or steel products is unreasonable or inconsistent with the public interest of the State of West Virginia, (2) that domestic aluminum, glass or steel products are not produced in sufficient quantities to meet the contract requirements, or (3) the available domestic aluminum, glass, or steel do not meet the contract specifications. This provision only applies to public works contracts awarded in an amount more than fifty thousand dollars (\$50,000) or public works contracts that require more than ten thousand pounds of steel products.

The cost of domestic aluminum, glass, or steel products may be unreasonable if the cost is more than twenty percent (20%) of the bid or offered price for foreign made aluminum, glass, or steel products. If the domestic aluminum, glass or steel products to be supplied or produced in a

“substantial labor surplus area”, as defined by the United States Department of Labor, the cost of domestic aluminum, glass, or steel products may be unreasonable if the cost is more than thirty percent (30%) of the bid or offered price for foreign made aluminum, glass, or steel products. This preference shall be applied to an item of machinery or equipment, as indicated above, when the item is a single unit of equipment or machinery manufactured primarily of aluminum, glass or steel, is part of a public works contract and has the sole purpose or of being a permanent part of a single public works project. This provision does not apply to equipment or machinery purchased by a spending unit for use by that spending unit and not as part of a single public works project.

All bids and offers including domestic aluminum, glass or steel products that exceed bid or offer prices including foreign aluminum, glass or steel products after application of the preferences provided in this provision may be reduced to a price equal to or lower than the lowest bid or offer price for foreign aluminum, glass or steel products plus the applicable preference. If the reduced bid or offer prices are made in writing and supersede the prior bid or offer prices, all bids or offers, including the reduced bid or offer prices, will be reevaluated in accordance with this rule.

44. INTERESTED PARTY SUPPLEMENTAL DISCLOSURE: W. Va. Code § 6D-1-2 requires that for contracts with an actual or estimated value of at least \$1 million, the vendor must submit to the Agency a supplemental disclosure of interested parties reflecting any new or differing interested parties to the contract, which were not included in the original pre-award interested party disclosure, within 30 days following the completion or termination of the contract. A copy of that form is included with this solicitation or can be obtained from the WV Ethics Commission. This requirement does not apply to publicly traded companies listed on a national or international stock exchange. A more detailed definition of interested parties can be obtained from the form referenced above.

DESIGNATED CONTACT: Vendor appoints the individual identified in this Section as the Contract Administrator and the initial point of contact for matters relating to this Contract.

Shaji Habib, Sales Manager
(Name, Title)
Shaji Habib, Sales Manager
(Printed Name and Title)
1349 South International Pkwy, Suite 2411, Lake Mary, Florida 32746
(Address)
407-359-2373 407-359-2372
(Phone Number) / (Fax Number)
tii@tii-usa.com
(email address)

CERTIFICATION AND SIGNATURE: By signing below, or submitting documentation through wvOASIS, I certify that I have reviewed this Solicitation in its entirety; that I understand the requirements, terms and conditions, and other information contained herein; that this bid, offer or proposal constitutes an offer to the State that cannot be unilaterally withdrawn; that the product or service proposed meets the mandatory requirements contained in the Solicitation for that product or service, unless otherwise stated herein; that the Vendor accepts the terms and conditions contained in the Solicitation, unless otherwise stated herein; that I am submitting this bid, offer or proposal for review and consideration; that I am authorized by the vendor to execute and submit this bid, offer, or proposal, or any documents related thereto on vendor's behalf; that I am authorized to bind the vendor in a contractual relationship; and that to the best of my knowledge, the vendor has properly registered with any State agency that may require registration.

Technology International, Inc.
(Company)
Rifat Habib Rifat Habib, Business Development Exec.
(Authorized Signature) (Representative Name, Title)

Rifat Habib, Business Development Exec.
(Printed Name and Title of Authorized Representative)

10/11/2019
(Date)

407-359-2373 407-359-2372
(Phone Number) (Fax Number)

REQUEST FOR QUOTATION, RFQ# EBAr67821r2
Automatic Air Dehydrators

SPECIFICATIONS

- 1. PURPOSE AND SCOPE:** The West Virginia Purchasing Division is soliciting bids on behalf of the West Virginia Educational Broadcasting Authority, an agency of the State of West Virginia, to establish a contract for the one-time purchase of Automatic Air Dehydrators.

- 2. DEFINITIONS:** The terms listed below shall have the meanings assigned to them below. Additional definitions can be found in section 2 of the General Terms and Conditions.
 - 2.1 Automatic Membrane Dehydrator:** a dehydrator that automatically removes moisture by passing the incoming wet air through a membrane module.

 - 2.2 Contract Item:** means automatic air dehydrators as more fully described by these specifications.

 - 2.3 Cut In/Out Pressure:** the tank pressure at which the air dehydrator either “cuts in”, or starts, or “cuts out” or stops.

 - 2.4 Dry Form C Contact:** a "dry" contact is one that is a hard contact such as a relay or switch. A Form C Contact is also called SPDT (Single Pole Double Throw) and breaks the connection with one throw before making contact with the other (break-before-make).

 - 2.5 PSIG (Pounds per Square Inch Gauge):** indicates the pressure is relative to atmospheric pressure.

 - 2.6 Pricing Page:** the page(s), contained in wvOASIS or attached as Exhibit A, upon which Vendor should list its proposed price for the Contract Items.

 - 2.7 PTFE (PolyTetraFluoroEthylene) Tape:** a tape commonly used in plumbing to seal threads - also known as plumber’s tape or Teflon tape.

 - 2.8 SCFM (Standard Cubic Feet per Minute):** the molar flow rate of a gas corrected to "standardized" conditions of temperature and pressure thus representing a fixed number of moles of gas regardless of composition and actual flow conditions.

 - 2.9 SLPM (Standard Liter Per Minute):** a unit of volumetric flow rate of a gas corrected to "standardized" conditions of temperature and pressure (STP).

 - 2.10 Solicitation:** means the official notice of an opportunity to supply the State with goods or services that is published by the Purchasing Division.

REQUEST FOR QUOTATION, RFQ# EBAr67821r2
Automatic Air Dehydrators

3. GENERAL REQUIREMENTS:

3.1 Mandatory Contract Item Requirements: Contract Item must meet or exceed the mandatory requirements listed below.

3.1.1 Item# 1: Automatic air dehydrator, quantity 10. Must meet or exceed the following specifications:

3.1.1.1 Dehydrator Type: Automatic Membrane

3.1.1.2 Voltage Type: ac

3.1.1.3 Volume Capacity, minimum 42.48 Liter | 1.50 Cubic Feet

3.1.1.4 Volume Capacity, maximum 1699.00 Liter | 60.00 Cubic Feet

3.1.1.5 Cut In/Out Pressure Type factory set

3.1.1.5.1.1 Cut In Pressure 13.79 kilopascal | 2.00 psig

3.1.1.5.1.2 Cut Out Pressure 34.47 kilopascal | 5.00 psig

3.1.1.6 Dew Point Better than -45 °C (-50 °F) at 95% Relative Humidity at +40 °C (+104 °F)

3.1.1.7 Flow Rate 4.20 SLPM | 0.15 SCFM

3.1.1.8 Must include the following accessories:

3.1.1.8.1 a minimum of 10 feet of 3/8 in polyethylene tubing

3.1.1.8.2 90° elbow fitting

3.1.1.8.3 Male connector fitting

3.1.1.8.4 Needle valve

3.1.1.8.5 Power cord

3.1.1.8.6 Power cord connector lock on unit

3.1.1.8.7 PTFE tape

3.1.1.9 Single output port - Port Count 1

3.1.1.10 Port Type 3/8 in polyethylene tube

3.1.2 Electrical

3.1.2.1 Power Cord USA power cord

3.1.2.2 Voltage 115 VAC (Volts Alternating Current) ±10%

REQUEST FOR QUOTATION, RFQ# EBAr67821r2
Automatic Air Dehydrators

- 3.1.2.3 Alarm Contact Rating Dry Form C contacts, 2 amps at 30 VDC (Volts Direct Current)
- 3.1.2.4 Operating Temperature -10 °C to +50 °C (+14 °F to +122 °F)
- 3.1.2.5 Power Consumption 215.0 Watts
- 3.1.2.6 Power Frequency 60 Hertz
- 3.1.2.7 Power Phase Single

3.1.3 Alarm

- 3.1.3.1 Alarm Type Summary
- 3.1.3.2 Excess-Run (amount of continuous dehydrator run time considered excessive) contact closure Alarm at 10 minutes, factory set
- 3.1.3.3 Low-Pressure contact closure Alarm at 1 PSIG, factory set

4. CONTRACT AWARD:

4.1 Contract Award: The Contract is intended to provide Agencies with a purchase price for the Contract Items. The Contract shall be awarded to the Vendor that provides the Contract Items meeting the required specifications for the lowest overall total cost as shown on the Pricing Pages (Exhibit A).

4.2 Pricing Page: Vendor should complete the Pricing Page (Addendum A) by filling the table with the appropriate information. Vendor should complete the Pricing Page in full as failure to complete the Pricing Page in its entirety may result in Vendor's bid being disqualified.

- 4.2.1 Vendor should complete the Pricing Page (Exhibit A) by listing a Unit Cost for each Contract Item, multiplying this unit cost by the given quantity, and listing the result as a Total Item Cost for each Contract Item. Vendor should then enter a sum of all Total Item Costs in the Total Bid Cost field.
- 4.2.2 Shipping costs shall be included in the price of equipment.
- 4.2.3 Vendor must provide additional documentation for all equipment and components to sufficiently demonstrate that all equipment meets specifications. Vendor should provide this documentation with their bid.
- 4.2.4 Vendor should type or electronically enter the information into the Pricing Page (Exhibit A) to prevent errors in the evaluation.
- 4.2.5 The total cost of the bid shall be the "Total Bid Cost" as described in section 4.2.1.

REQUEST FOR QUOTATION, RFQ# EBAr67821r2
Automatic Air Dehydrators

- 4.2.6 The winning Vendor shall be the vendor submitting the bid with the lowest total cost.
- 4.2.7 If no vendor submits a bid within the budget limitations of the Agency, the Agency may, at its own discretion, cancel this RFQ and purchase nothing.

5. PAYMENT:

- 5.1 **Payment:** Vendor shall accept payment in accordance with the payment procedures of the State of West Virginia.

6. DELIVERY AND RETURN:

- 6.1 **Shipment and Delivery:** Vendor shall ship the Contract Items immediately after being awarded this Contract and receiving a purchase order or notice to proceed. Vendor shall deliver the Contract Items within 15 working days after receiving a purchase order or notice to proceed. Contract Items must be delivered to the Agency at the following address:

WV Educational Broadcasting Authority
Attn: Ollin D. McClanahan
600 Capitol St
Charleston, WV 25301

- 6.2 **Late Delivery:** The Agency placing the order under this Contract must be notified in writing if the shipment of the Contract Items will be delayed for any reason. Any delay in delivery that could cause harm to an Agency will be grounds for cancellation of the Contract, and/or obtaining the Contract Items from a third party.

Any Agency seeking to obtain the Contract Items from a third party under this provision must first obtain approval of the Purchasing Division.

- 6.3 **Delivery Payment/Risk of Loss:** Vendor shall deliver the Contract Items F.O.B. destination to the Agency's location.
- 6.4 **Return of Unacceptable Items:** If the Agency deems the Contract Items to be unacceptable, the Contract Items shall be returned to Vendor at Vendor's expense and with no restocking charge. Vendor shall either make arrangements for the return within five (5) days of being notified that items are unacceptable or permit the Agency to arrange for the return and reimburse the Agency for delivery expenses. If the original packaging cannot be utilized for the return, Vendor will supply the Agency with appropriate return packaging upon request. All returns of unacceptable

REQUEST FOR QUOTATION, RFQ# EBAr67821r2
Automatic Air Dehydrators

items shall be F.O.B. the Agency's location. The returned product shall either be replaced, or the Agency shall receive a full credit or refund for the purchase price, at the Agency's discretion.

- 6.5 Return Due to Agency Error:** Items ordered in error by the Agency will be returned for credit within 30 days of receipt, F.O.B. Vendor's location. Vendor shall not charge a restocking fee if returned products are in a resalable condition. Items shall be deemed to be in a resalable condition if they are unused and in the original packaging. Any restocking fee for items not in a resalable condition shall be the lower of the Vendor's customary restocking fee or 5% of the total invoiced value of the returned items.

7 VENDOR DEFAULT:

7.1 The following shall be considered a vendor default under this Contract.

- 7.1.1 Failure to provide Contract Items in accordance with the requirements contained herein.
- 7.1.2 Failure to comply with other specifications and requirements contained herein.
- 7.1.3 Failure to comply with any laws, rules, and ordinances applicable to the Contract Services provided under this Contract.
- 7.1.4 Failure to remedy deficient performance upon request.

7.2 The following remedies shall be available to Agency upon default.

- 7.2.1 Immediate cancellation of the Contract.
- 7.2.2 Immediate cancellation of one or more release orders issued under this Contract.
- 7.2.3 Any other remedies available in law or equity.

REQUEST FOR QUOTATION, RFQ# EBAr67821r2
Automatic Air Dehydrators

Exhibit A
Pricing Page*

Item#	Description	Quan	Unit Cost	Total Item Cost
1	Automatic Air Dehydrators as described in section 3.1.1	4	\$ 4,359.00	\$ 17,436.00
	Total Bid Cost			\$ 17,436.00

***Per section 4.2.3 Vendor must also provide documentation for the equipment quoted sufficient for the Agency to determine whether the quoted equipment meets specifications. This documentation should be provided with Vendor's bid.**

Authorized Signature:



Rifat Habib, Business Development Exec.

Date:

10/11/2019

STATE OF WEST VIRGINIA
Purchasing Division

PURCHASING AFFIDAVIT

CONSTRUCTION CONTRACTS: Under W. Va. Code § 5-22-1(i), the contracting public entity shall not award a construction contract to any bidder that is known to be in default on any monetary obligation owed to the state or a political subdivision of the state, including, but not limited to, obligations related to payroll taxes, property taxes, sales and use taxes, fire service fees, or other fines or fees.

ALL CONTRACTS: Under W. Va. Code §5A-3-10a, no contract or renewal of any contract may be awarded by the state or any of its political subdivisions to any vendor or prospective vendor when the vendor or prospective vendor or a related party to the vendor or prospective vendor is a debtor and: (1) the debt owed is an amount greater than one thousand dollars in the aggregate; or (2) the debtor is in employer default.

EXCEPTION: The prohibition listed above does not apply where a vendor has contested any tax administered pursuant to chapter eleven of the W. Va. Code, workers' compensation premium, permit fee or environmental fee or assessment and the matter has not become final or where the vendor has entered into a payment plan or agreement and the vendor is not in default of any of the provisions of such plan or agreement.

DEFINITIONS:

"Debt" means any assessment, premium, penalty, fine, tax or other amount of money owed to the state or any of its political subdivisions because of a judgment, fine, permit violation, license assessment, defaulted workers' compensation premium, penalty or other assessment presently delinquent or due and required to be paid to the state or any of its political subdivisions, including any interest or additional penalties accrued thereon.

"Employer default" means having an outstanding balance or liability to the old fund or to the uninsured employers' fund or being in policy default, as defined in W. Va. Code § 23-2c-2, failure to maintain mandatory workers' compensation coverage, or failure to fully meet its obligations as a workers' compensation self-insured employer. An employer is not in employer default if it has entered into a repayment agreement with the Insurance Commissioner and remains in compliance with the obligations under the repayment agreement.

"Related party" means a party, whether an individual, corporation, partnership, association, limited liability company or any other form or business association or other entity whatsoever, related to any vendor by blood, marriage, ownership or contract through which the party has a relationship of ownership or other interest with the vendor so that the party will actually, or by effect, receive or control a portion of the benefit, profit or other consideration from performance of a vendor contract with the party receiving an amount that meets or exceeds five percent of the total contract amount.

AFFIRMATION: By signing this form, the vendor's authorized signer affirms and acknowledges under penalty of law for false swearing (W. Va. Code §61-5-3) that: (1) for construction contracts, the vendor is not in default on any monetary obligation owed to the state or a political subdivision of the state, and (2) for all other contracts, that neither vendor nor any related party owe a debt as defined above and that neither vendor nor any related party are in employer default as defined above, unless the debt or employer default is permitted under the exception above.

WITNESS THE FOLLOWING SIGNATURE:

Vendor's Name: Technology International, Inc.

Authorized Signature: Rifat Habib Rifat Habib, Business Development Exec. Date: 10/11/2019

State of Florida

County of Seminole, to-wit:

Taken, subscribed, and sworn to before me this 11 day of October, 2019

My Commission expires 10/15/2022, 2022

AFFIX SEAL HERE

NOTARY PUBLIC M. A. H.

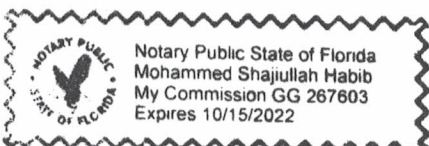



Technology International, Inc.
 1349 South International Pkwy, Suite 2411
 Lake Mary, FL 32746
 Tel: (407) 359-2373
 Fax: (407) 359-2372
 E-mail: tii@tii-usa.com
 Website: www.tii-usa.com

Equipment Proposal

Description: Autmatic Air Dehydrator Open End Contract

Solicitation #: CRFQ 0439 EBA2000000010

Attention: Bid Clerk
 Department of Administration
 Purchasing Division
 2019 Washington ST E
 Charleston WV 25305
 Phone: 304-558-8801

Our Ref: TII/WV/1019/12525

Date: 10/11/2019

In response to your quote request for Autmatic Air Dehydrator Open End Contract, Technology International, Inc. is pleased to submit the following for consideration:

ITEM NO.	QTY	DESCRIPTION/ MODEL NO.	UNIT PRICE	EXTD. PRICE
1	4	Viking Satcom Part # ETI-23437 ADH NETCOM Automatic Dehydrator, AC <u>Includes:</u> <ul style="list-style-type: none"> • Part # ETI-16727 Fitting, 90° Elbow, Compression Male 1/8" NPT – 3/8" OD Tubing, Brass (Qty 4) • Part # ETI-16725 Fitting, Straight, Compression Male 1/8" NPT – 3/8" OD Tubing, Brass (Qty 4) • Part # ETI-23103 Tubing, Black Polyethylene UV resistant semi-rigid, 1/4"ID, 3/8" OD, Black, 25' (Qty 4) 	\$4,359.00	\$17,436.00
See attached data sheets				
Total price for all above.....			\$17,436.00	

Warranty: Manufacturer's Standard warranty applies. Two (2) years warranty.

Delivery:

- Estimated delivery is **12 WEEKS** after receipt of order and approved submittal
- All delivery dates quoted are subject to manufacturer's confirmation at time of order.
- Submittal data will be provided for approval after receipt of order (if applicable).
- Customer to provide equipment and personnel to unload.
- TII will deliver good title (MSO) to the Agency upon payment confirmation. The Agency is responsible for its own title work and registration (if applicable).

Freight: Freight Included to Charleston, WV 25301.

Validity: Quote is valid for 30 days.

Payment Terms: NET 30

Prompt Payment discount: 1/4 % 10 days

Technology International, Inc. Corporate data:

We are a small business and our Tax Payer Identification Number (TIN): 650342335. The above price quoted does not include any sales, excise or similar taxes. If applicable agency must accrue and remit it directly."

We trust that this proposal will meet your requirements and we look forward to hearing from you.

If you have any questions or need more information, please contact us by phone at 407-359-2373, fax at 407-359-2372 or email us at tii@tii-usa.com

Respectfully submitted,



Rifat Habib
Business Development Exec.
Technology International, Inc.

Packing List

Qty	ETI P/N	Description
1	23437	ADH NETCOM Automatic Dehydrator, AC Power Supply
1	24303	Documentation CD ROM, ADH NETCOM and ASM-1 Smart Manifold
1	23617	ADH NETCOM Installation Sheet (this document)
1	17618	Power Cord, Euro
1	18198	1/8" NPT to 1/4" Barbed Brass Fitting
1	23428	1/8" NPT to 3/8" Barbed Brass Fitting
1	14513	1/8" NPT to 1/4" Barbed Elbow Brass Fitting
4	23245	Mounting Bracket
8	24567	Self-Locking Rack-mounting screw (#8-32)
8	10641	#8 Split Washer

Connections

1. Connect feed hose to 1/8" NPT outlet using 1/4" or 3/8" barbed fitting supplied.
2. Connect required data and alarm relay ports. RS-422 and RS-232 ports may require configuration changes via the web interface. See Instruction Manual for more information.
3. Connect AC power cord. System can be connected to 100 VAC – 240 VAC power without requiring any configuration change.

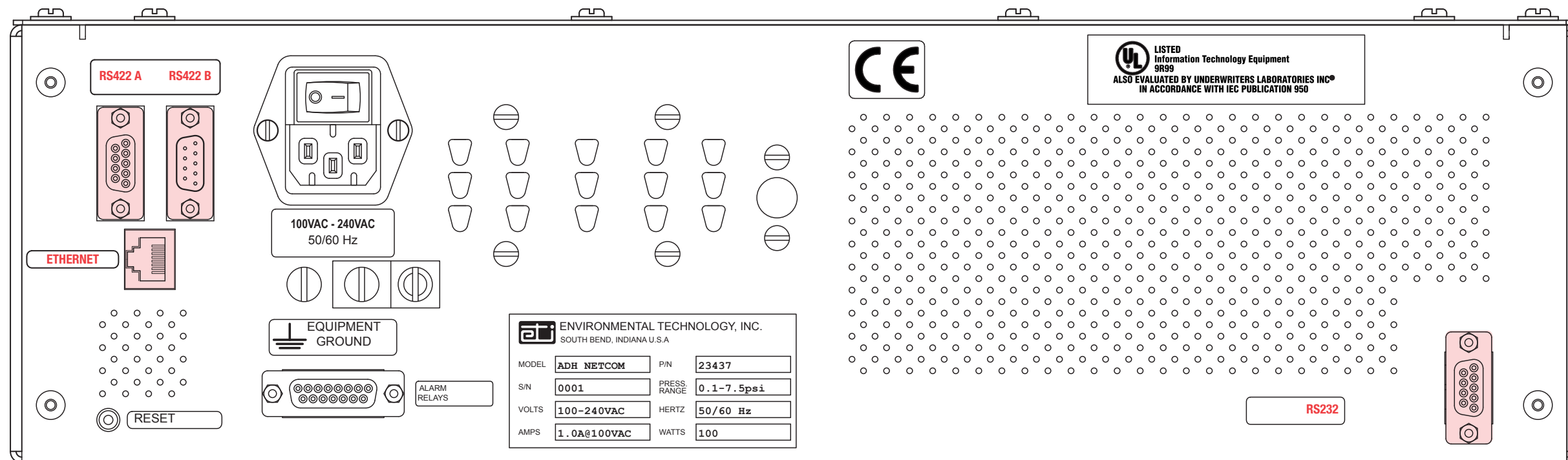

IP Configuration

Obtain IP address automatically
 Use the following IP address:

IP address:
 IP mask:
 Gateway:
 Network Name:

Submit Reset

Communicating With the Dehydrator

Note: Your Information Technology Department is the best source of information if you encounter problems or difficulties in connecting to or communicating with the dehydrator. The ADH NETCOM Ethernet communications run at 10Base-T data rate and half duplex. It is recommended that the network interface to the ADH NETCOM is manually set to these parameters and NOT to an auto-configuration mode.

1. Temporarily assign computer an IP address in the 192.168.52.0 network range, typically 192.168.52.1, with the subnet 255.255.255.0
2. Connect the dehydrator to your computer either directly or through a network. For direct connections a cross-over cable or switch may be required for connecting to an older computer; an Ethernet patch cable will work in most other cases.
3. Open a web browser and connect to web interface at HTTP://192.168.52.9

Configuring IP Address

1. Go to Configuration page
2. If using a fixed IP address, select "Use the following IP address:" Then set the IP address, mask and gateway.
3. If using DHCP, select "Obtain IP address automatically."
4. Click Submit. You should see a message that the dehydrator is rebooting.

Note: After changing the IP address of your dehydrator to a network other than the default 192.168.52.0 you will not be able to access the dehydrator from the configuring computer unless that computer is reconfigured for the newly assigned network address.

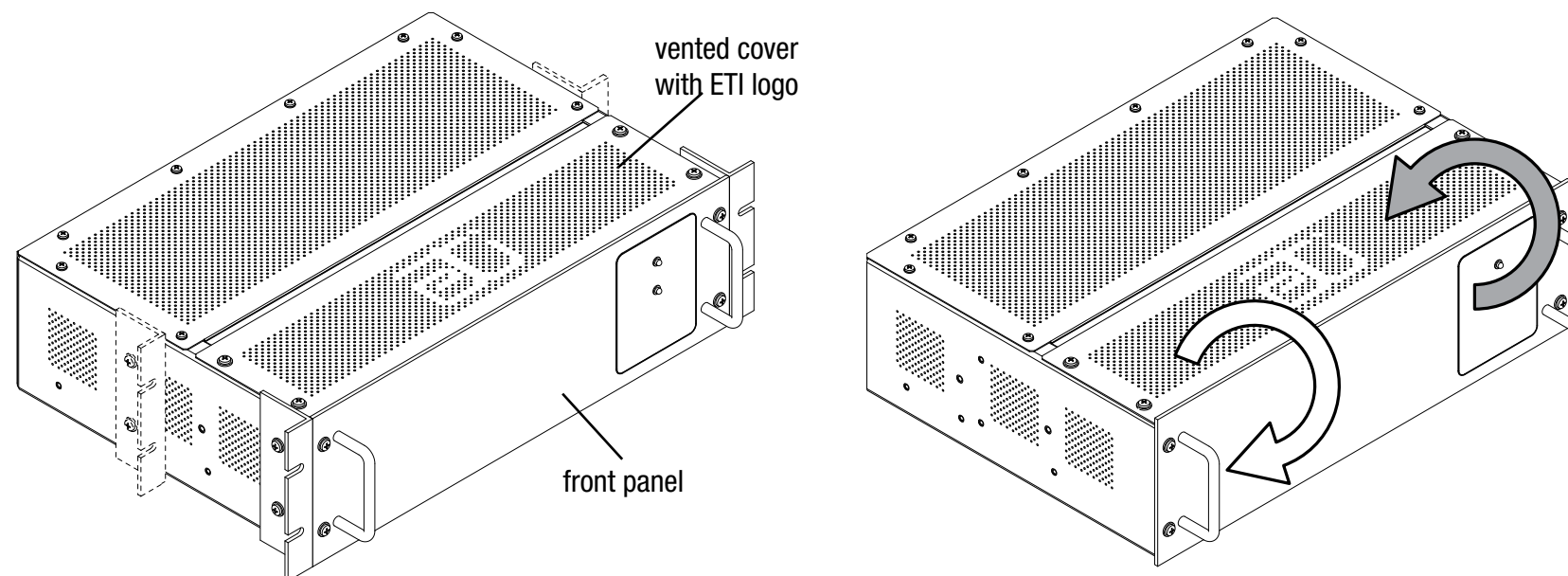

Rack Mounting

The dehydrator is equipped with positions for either flush-mounting (for dual-post racks and enclosures) or center-mounting (for single-post racks).

If using mounting rails (not supplied), do not install mounting brackets.

Wall Mounting Configuration

To configure the dehydrator for wall mount installation, remove the front panel and the portion of the vented cover with the ETI logo. Reinstall the front panel so that it will be in the new front position once the dehydrator is positioned for wall mounting. Reinstall the small vented panel so that it will be in the new bottom position.

Wall Mounting

Ensure the mounting surface and hardware are suitable to support a static load of approximately four times the weight of the unit, or 64 pounds (29 kg). Use four appropriate 5/16" mounting hardware to fasten the unit and ensure stable mounting. The dehydrator is equipped with four brackets for wall mounting.

Pressure parameters

Low Pressure Alarm:
 Low Limit Pressure:
 High Limit Target Pressure:
 High Pressure Alarm:
 Units:
 Small System:

Submit Reset

Configuring Pressure

1. Using a web browser, connect to the dehydrator. Go to the Configuration page
2. Using the Units pull-down select English (PSI) or SI (mbar).
3. To change the operational pressure setting enter the following:
 - Low Alarm - The pressure at which Low Pressure will cause an alarm condition.
 - Low Limit - The low set point at which the unit will start pumping.
 - High Limit - The high set point at which the unit will stop pumping.
 - High Alarm - The pressure at which High Pressure will cause an alarm condition.
4. Click submit.

DISCLAIMER

Environmental Technology, Inc. makes no representations or warranties, either expressed or implied, with respect to the contents of this publication or the products that it describes, and specifically disclaims any implied warranties of merchantability or fitness for any particular purpose. Environmental Technology, Inc. reserves the right to revise this publication, and to make changes and improvements to the products described in this publication, without the obligation of Environmental Technology, Inc. to notify any person or organization of such revisions, changes or improvements.

The ETI logo, We Manage Heat and ADH are registered trademarks of Environmental Technology, Inc. NETCOM is a trademark of Environmental Technology, Inc. Copyright © 2014 Environmental Technology, Inc. All rights reserved.



FEATURES & BENEFITS

- Provides dry pressurized air to ensure signal quality of antenna waveguide and dielectric coaxial cable
- Highly configurable to meet the needs of wide ranging applications
- Field programmable operating pressure range from 0.10 psig to 7.50 psig (7mbar to 517mbar)
- Brushless dual-diaphragm compressor for long life
- Future-proof software based features allow updates and upgrades while in service
- Remote monitoring and control with web interface or SNMP
- Configurable Master/Slave operations
- Ethernet, RS-422/485, RS-232 and alarm relay outputs for compatibility with nearly any system
- Optional front panel with display allows for IP configuration and status monitoring when no network is available
- Simple power connections for 100-240 VAC or $\pm 20-75$ VDC
- Small, light weight chassis with multiple mounting options makes installation easy
- Low energy use minimizes lifetime operational costs
- Quiet operation

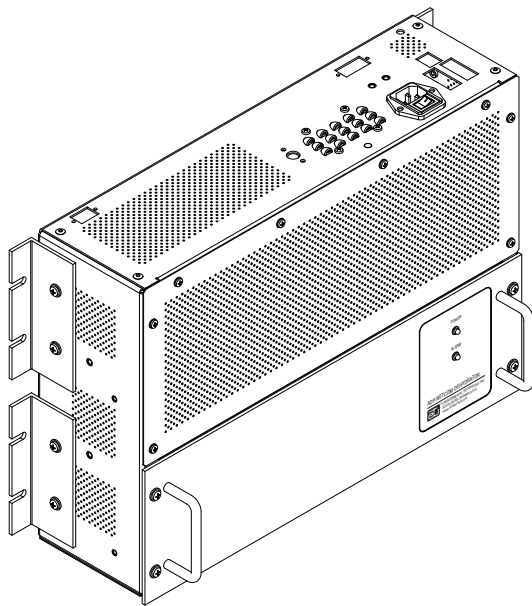

Wall Mount

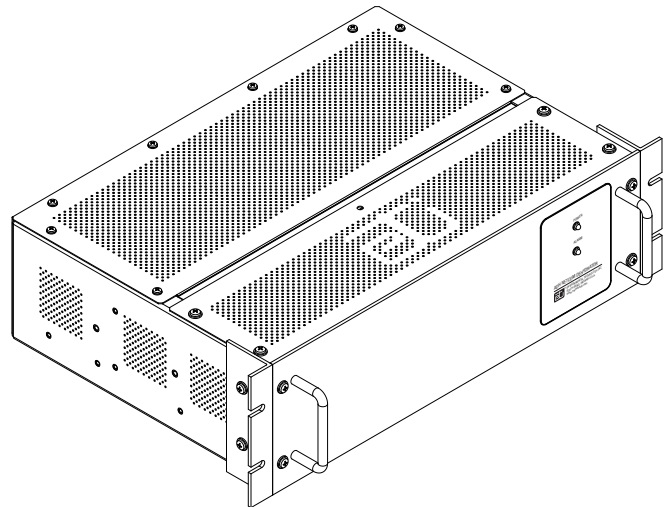

Rack Mount

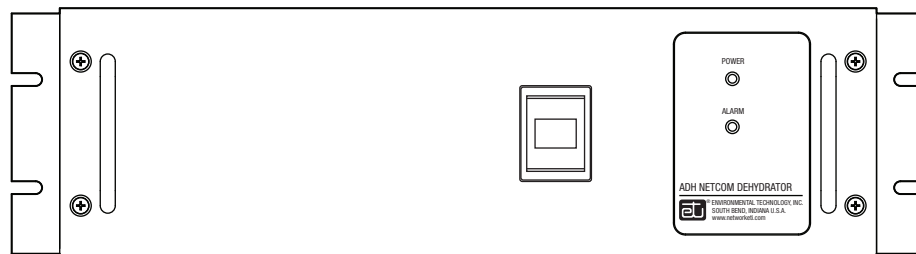

Optional Front Panel with Display

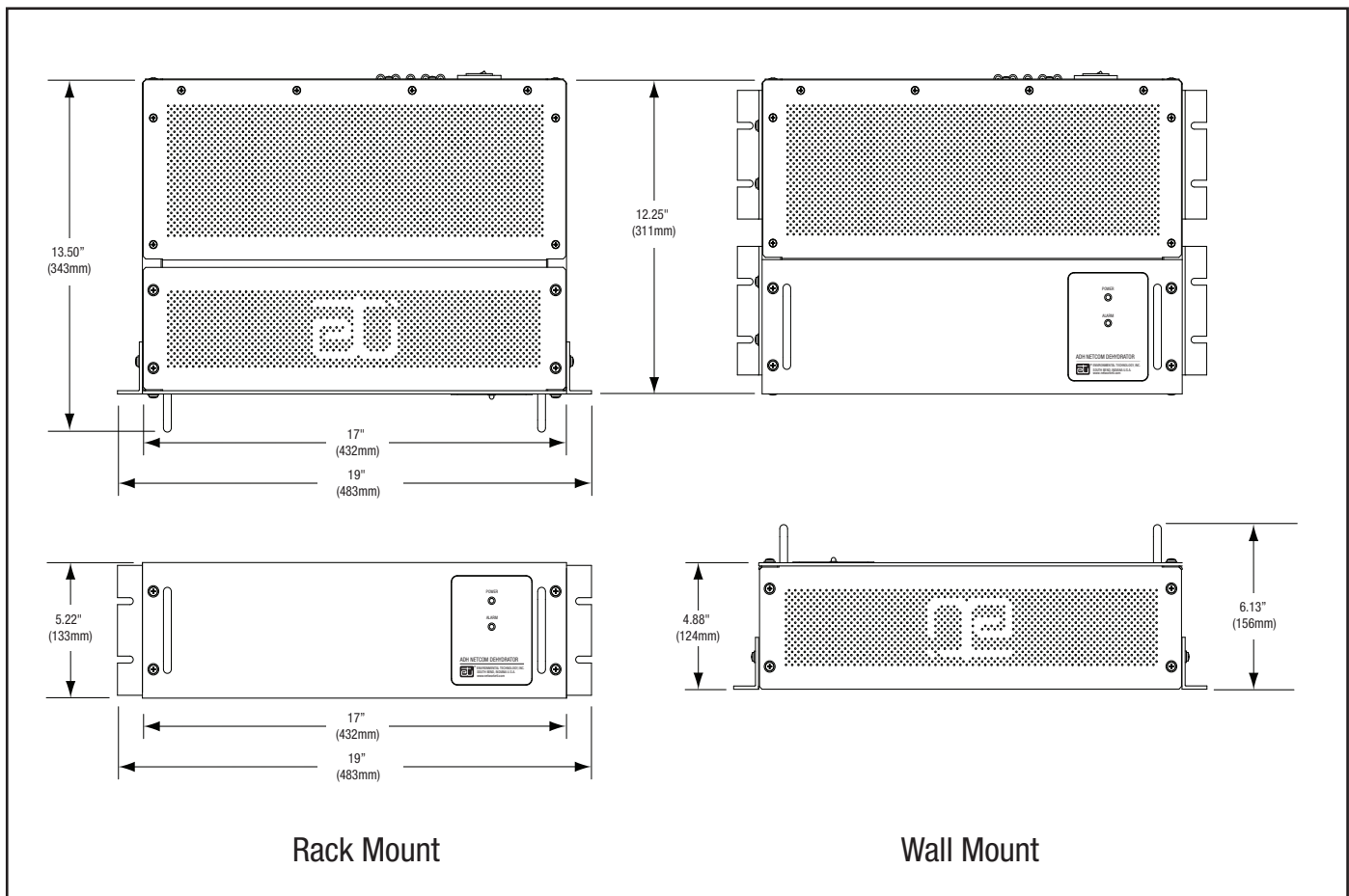

Rack Mount

Wall Mount

DESCRIPTION

The ADH NETCOM automatic dehydrator supplies low pressure dry air to keep waveguide and coaxial cable dry. Output pressure is field configurable between 0.10 psig and 7.50 psig (7mbar - 517mbar) in 0.01 psig (0.67mbar) increments. Factory default pressure is 0.5 psig (34.5mbar). Operational monitoring and alarms are software based making them highly configurable in the field. Future software features can be installed while in service over the internet or local Ethernet network.

The ADH NETCOM automatic dehydrator is Ethernet network ready. Units can be configured and monitored using either built-in SNMP support or the web interface. Legacy system support is provided via RS-422/485 or RS-232 interfaces. Three programmable alarm relays are also

included. User display shows output pressure, duty cycle, temperature, compressor hours and air drying canister status.

The ADH NETCOM automatic dehydrator uses a brushless dual-diaphragm pump for long life. Dehydrator operates with exceptionally low noise and vibration levels. The air drying canisters use aluminum oxide desiccant for high efficiency. The humidity sensor signals for regeneration based upon current dew point rather than at fixed time intervals for additional energy savings and long desiccant life.

The ADH NETCOM automatic dehydrator requires only 5-1/4" (3-U) of rack space and is just 12" (304.8mm) deep. Mounting hardware allows for flexible installation options including dual- and single-post rack mounting and wall mounting. The standard unit

weighs just 16 lbs (7.26 kg).

The ADH NETCOM automatic dehydrator operates from 100-240 VAC, 50/60 Hz. Optional units are also available at $\pm 20-75$ VDC. The dehydrator consumes a maximum of 150 watts during regeneration and about 40 watts otherwise. Heat dissipated is up to 512 BTU/hr during regeneration and about 136 BTU/hr otherwise. The ADH NETCOM creates an exceptionally low heat load for an automatic dehydrator.

An optional front panel with display allows for IP configuration and status monitoring when no network is available.

For complete information describing application, installation and features, please contact ETI Customer Service or visit www.networketi.com.

SPECIFICATIONS

General

Approvals

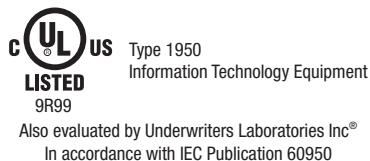

Regeneration Method	Automatic, demand
Maximum dew point	-40° F/C

Enclosure

Dimensions	17" × 12" × 5-1/4" (432mm × 305mm × 133mm)
Weight	16 lbs (7.26 kg)
Mounting	Dual-post rack, flush mounted Single-post rack, center mounted Wall mounted

Power

Supply	100-240 VAC, 50/60 Hz ±20-75 VDC
Maximum current	1.0 Amps at 100 V
Power usage	40 W typical, 150 W max
Heat dissipation	136 BTU/hr typical @40 W, 512 BTU/hr max @150 W

Output

Flow rate	25.4 scfh (12 lpm)
Maximum pressure	7.5 psig (517mbar)
Internal safety relief valve	8 psig (552mbar)
Discharge port	1/8" NPT 3/8" or 1/4" hose barb (both included)
Display units	SI (millibars); English (psig), default

Control

Protocols	HTTP (Web Interface), SNMP, UDP, TFTP
Maximum pressure	Configurable Range: 0.20 psig - 7.5 psig (14mbar - 517mbar), Default: 0.50 psig (34.5mbar)
Minimum pressure	Configurable Range: 0.10 psig - 7.4 psig (7mbar - 510mbar), Default: 0.30 psig (21mbar)
Low pressure alarm level	User Configurable, Default: 0.15 psig (10mbar)
High pressure alarm level	User Configurable, Default: 1.5 psig (103.5mbar)
Alarm relays	Contact Type - Form C, SPDT, reverse acting Ratings - 0.25 Amps @ 60 V User Configurable, Defaults - Alarm Relay 1: Summary Alarm, Alarm Relay 2: Low Pressure Alarm, Alarm Relay 3: Over Pressure Alarm
Duty cycle alarm	User Configurable, Default: 50%
Master/Slave configuration	User Configurable, Default: Standard/Slave

Environmental

Operating temperature	32°F to 130°F (0°C to 55°C)
Storage temperature	-40°F to 150°F (-40°C to 60°C)

ORDERING INFORMATION

Order Number	Description
23437	ADH NETCOM Automatic Dehydrator, 100-240 VAC
24658	ADH NETCOM Automatic Dehydrator, 100-240 VAC with Display
23242	ADH NETCOM Automatic Dehydrator, \pm 20-75 VDC
24659	ADH NETCOM Automatic Dehydrator, \pm 20-75 VDC with Display

LIMITED WARRANTY

ETI's two year limited warranty covering defects in workmanship and materials applies. Contact Customer Service for complete warranty information.

DISCLAIMER

Environmental Technology, Inc. makes no representations or warranties, either expressed or implied, with respect to the contents of this publication or the products that it describes, and **specifically disclaims any implied warranties of merchantability or fitness for any particular purpose**. Environmental Technology, Inc. reserves the right to revise this publication, and to make changes and improvements to the products described in this publication, without the obligation of Environmental Technology, Inc. to notify any person or organization of such revisions, changes or improvements.

Packing List

Qty	ETI P/N	Description
1	23437	ADH NETCOM Automatic Dehydrator, AC Power Supply
1	24303	Documentation CD ROM, ADH NETCOM and ASM-1 Smart Manifold
1	23617	ADH NETCOM Installation Sheet (this document)
1	17618	Power Cord, Euro
1	18198	1/8" NPT to 1/4" Barbed Brass Fitting
1	23428	1/8" NPT to 3/8" Barbed Brass Fitting
1	14513	1/8" NPT to 1/4" Barbed Elbow Brass Fitting
4	23245	Mounting Bracket
8	24567	Self-Locking Rack-mounting screw (#8-32)
8	10641	#8 Split Washer

Connections

1. Connect feed hose to 1/8" NPT outlet using 1/4" or 3/8" barbed fitting supplied.
2. Connect required data and alarm relay ports. RS-422 and RS-232 ports may require configuration changes via the web interface. See Instruction Manual for more information.
3. Connect AC power cord. System can be connected to 100 VAC – 240 VAC power without requiring any configuration change.

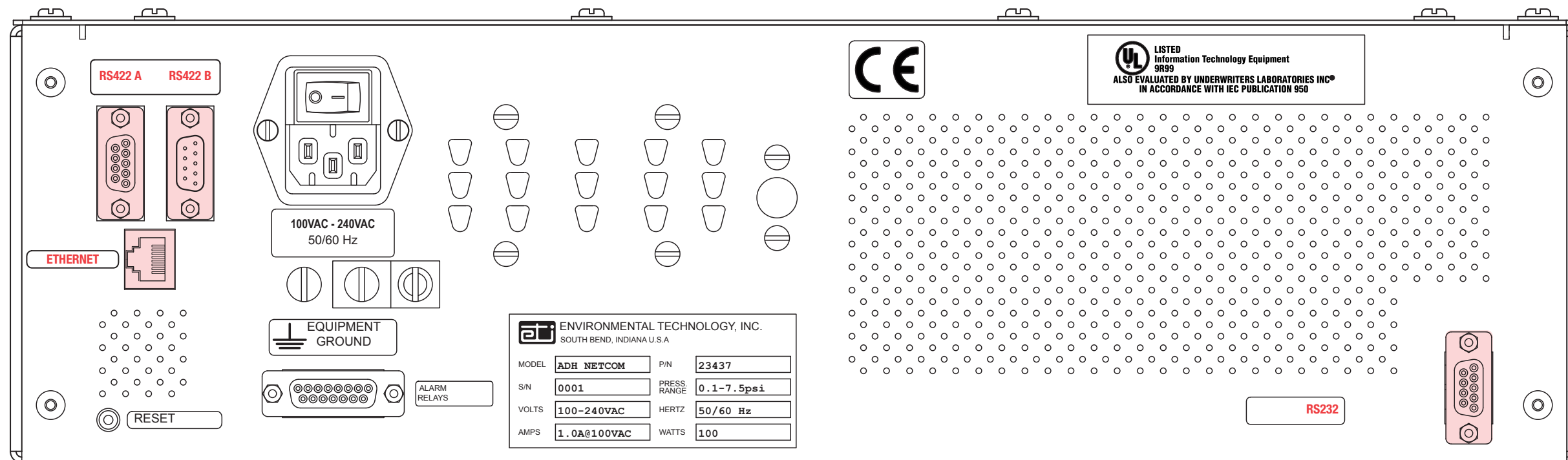

IP Configuration

Obtain IP address automatically
 Use the following IP address:

IP address:
 IP mask:
 Gateway:
 Network Name:

Submit Reset

Communicating With the Dehydrator

Note: Your Information Technology Department is the best source of information if you encounter problems or difficulties in connecting to or communicating with the dehydrator. The ADH NETCOM Ethernet communications run at 10Base-T data rate and half duplex. It is recommended that the network interface to the ADH NETCOM is manually set to these parameters and NOT to an auto-configuration mode.

1. Temporarily assign computer an IP address in the 192.168.52.0 network range, typically 192.168.52.1, with the subnet 255.255.255.0
2. Connect the dehydrator to your computer either directly or through a network. For direct connections a cross-over cable or switch may be required for connecting to an older computer; an Ethernet patch cable will work in most other cases.
3. Open a web browser and connect to web interface at HTTP://192.168.52.9

Configuring IP Address

1. Go to Configuration page
2. If using a fixed IP address, select "Use the following IP address:" Then set the IP address, mask and gateway.
3. If using DHCP, select "Obtain IP address automatically."
4. Click Submit. You should see a message that the dehydrator is rebooting.

Note: After changing the IP address of your dehydrator to a network other than the default 192.168.52.0 you will not be able to access the dehydrator from the configuring computer unless that computer is reconfigured for the newly assigned network address.

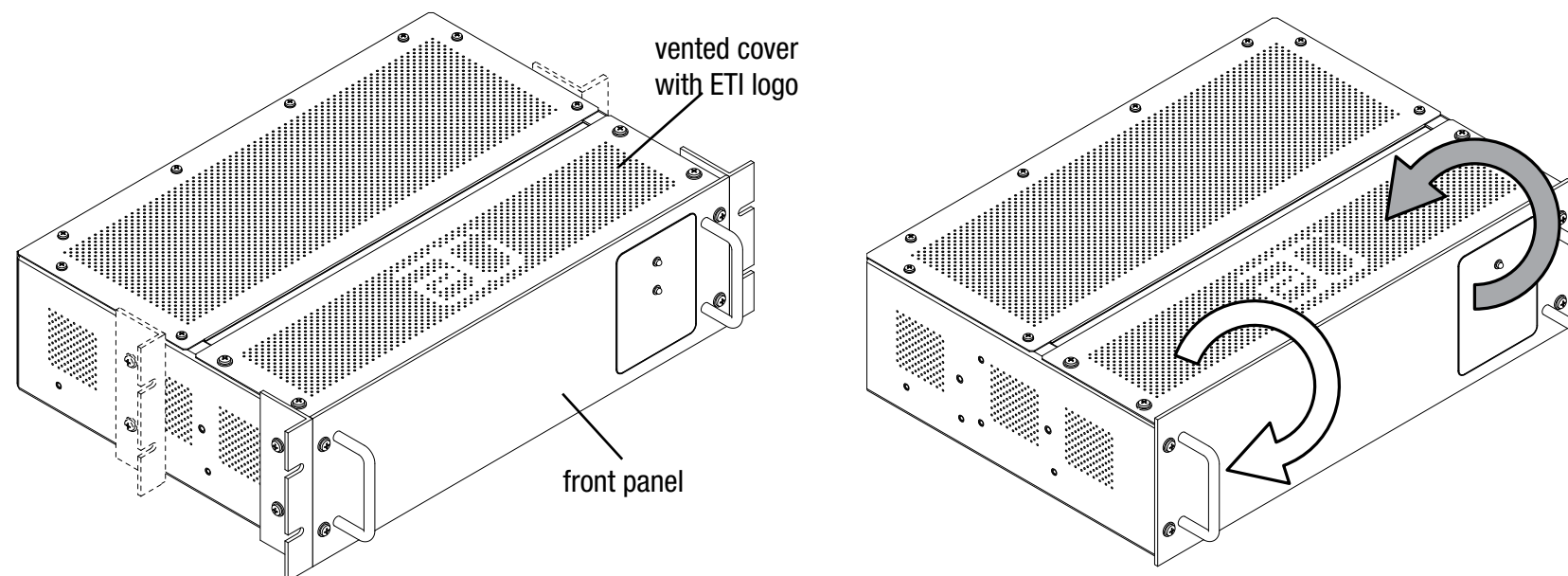

Rack Mounting

The dehydrator is equipped with positions for either flush-mounting (for dual-post racks and enclosures) or center-mounting (for single-post racks).

If using mounting rails (not supplied), do not install mounting brackets.

Wall Mounting Configuration

To configure the dehydrator for wall mount installation, remove the front panel and the portion of the vented cover with the ETI logo. Reinstall the front panel so that it will be in the new front position once the dehydrator is positioned for wall mounting. Reinstall the small vented panel so that it will be in the new bottom position.

Wall Mounting

Ensure the mounting surface and hardware are suitable to support a static load of approximately four times the weight of the unit, or 64 pounds (29 kg). Use four appropriate 5/16" mounting hardware to fasten the unit and ensure stable mounting. The dehydrator is equipped with four brackets for wall mounting.

Pressure parameters

Low Pressure Alarm:
 Low Limit Pressure:
 High Limit Target Pressure:
 High Pressure Alarm:
 Units:
 Small System:

Submit Reset

Configuring Pressure

1. Using a web browser, connect to the dehydrator. Go to the Configuration page
2. Using the Units pull-down select English (PSI) or SI (mbar).
3. To change the operational pressure setting enter the following:
 - Low Alarm - The pressure at which Low Pressure will cause an alarm condition.
 - Low Limit - The low set point at which the unit will start pumping.
 - High Limit - The high set point at which the unit will stop pumping.
 - High Alarm - The pressure at which High Pressure will cause an alarm condition.
4. Click submit.

Questions & Comments

For technical help, questions or comments concerning this product or any Environmental Technology, Inc. product contact Customer Service 8:00 a.m. - 5:00 p.m. EST.

Voice (800) 234-4239 USA & Canada or (574) 233-1202 elsewhere
 Fax (888) 234-4238 USA & Canada or (574) 233-2152 elsewhere
 Email info@networketi.com • Web <http://www.networketi.com>

DISCLAIMER

Environmental Technology, Inc. makes no representations or warranties, either expressed or implied, with respect to the contents of this publication or the products that it describes, and specifically disclaims any implied warranties of merchantability or fitness for any particular purpose. Environmental Technology, Inc. reserves the right to revise this publication, and to make changes and improvements to the products described in this publication, without the obligation of Environmental Technology, Inc. to notify any person or organization of such revisions, changes or improvements.

The ETI logo, We Manage Heat and ADH are registered trademarks of Environmental Technology, Inc. NETCOM is a trademark of Environmental Technology, Inc. Copyright © 2014 Environmental Technology, Inc. All rights reserved.