



The following documentation is an electronically-submitted vendor response to an advertised solicitation from the *West Virginia Purchasing Bulletin* within the Vendor Self-Service portal at wvOASIS.gov. As part of the State of West Virginia's procurement process, and to maintain the transparency of the bid-opening process, this documentation submitted online is publicly posted by the West Virginia Purchasing Division at WVPurchasing.gov with any other vendor responses to this solicitation submitted to the Purchasing Division in hard copy format.

Header 4

List View

General Information

Contact

Default Values

Discount

Document Information

Procurement Folder: 677055

SO Doc Code: CRFQ

Procurement Type: Central Purchase Order

SO Dept: 0313

Vendor ID: 000000166150

SO Doc ID: DEP2000000019

Legal Name: TRACTOR GUYS LLC

Published Date: 1/27/20

Alias/DBA:

Close Date: 1/31/20

Total Bid: \$43,999.00

Close Time: 13:30

Response Date: 01/31/2020

Status: Closed

Response Time: 13:08

Solicitation Description: Addendum No.01; Compact Track Excavator w ith Attachments

Total of Header Attachments: 4

Total of All Attachments: 4



Purchasing Division
 2019 Washington Street East
 Post Office Box 50130
 Charleston, WV 25305-0130

**State of West Virginia
 Solicitation Response**

Proc Folder : 677055
Solicitation Description : Addendum No.01; Compact Track Excavator with Attachments
Proc Type : Central Purchase Order

Date issued	Solicitation Closes	Solicitation Response	Version
	2020-01-31 13:30:00	SR 0313 ESR01312000000004530	1

VENDOR
000000166150 TRACTOR GUYS LLC

Solicitation Number: CRFQ 0313 DEP2000000019

Total Bid : \$43,999.00 **Response Date:** 2020-01-31 **Response Time:** 13:08:59

Comments:

FOR INFORMATION CONTACT THE BUYER
 Guy Nisbet
 (304) 558-2596
 guy.l.nisbet@wv.gov

Signature on File	FEIN #	DATE
--------------------------	---------------	-------------

All offers subject to all terms and conditions contained in this solicitation

Line	Comm Ln Desc	Qty	Unit Issue	Unit Price	Ln Total Or Contract Amount
1	Hydraulic Compact Track Excavator with Attachments	1.00000	EA	\$43,999.000000	\$43,999.00

Comm Code	Manufacturer	Specification	Model #
30190000			

Extended Description : Hydraulic Compact Track Excavator with Attachments, as listed in attached specifications.



Purchasing Division
 2019 Washington Street East
 Post Office Box 50130
 Charleston, WV 25305-0130

State of West Virginia
 Request for Quotation
 13 - Equipment

Proc Folder: 677055

Doc Description: Addendum No.01; Compact Track Excavator with Attachments

Proc Type: Central Purchase Order

Date Issued	Solicitation Closes	Solicitation No	Version
2020-01-27	2020-01-31 13:30:00	CRFQ 0313 DEP2000000019	2

BID RECEIVING LOCATION

BID CLERK
 DEPARTMENT OF ADMINISTRATION
 PURCHASING DIVISION
 2019 WASHINGTON ST E
 CHARLESTON WV 25305
 US

VENDOR

Vendor Name, Address and Telephone Number:

The Tractor Guys LLC
 87 wiseman run road
 Salem wv 26426
 304-615-6340

FOR INFORMATION CONTACT THE BUYER

Guy Nisbet
 (304) 558-2596
 guy.l.nisbet@wv.gov

Signature X Patrick Holguin  FEIN # 27-0951894

DATE 1/31/20

All offers subject to all terms and conditions contained in this solicitation

ADDITIONAL INFORMATION:

Addendum

Addendum No.01 issued to publish and distribute the attached information to the vendor community.

Request for Quotation
 (Hydraulic compact Tract Excavator w/Attachments)

The West Virginia Purchasing Division is soliciting bids on behalf of the West Virginia Department of Environmental Protection (WVDEP), Rehabilitation Environmental Action Plan (REAP), to establish a contract for the one-time purchase of one (1) Hydraulic Compact Track Excavator and the associated listed attachments for the same, per the bid requirements, specifications, terms and conditions as attached hereto.

INVOICE TO		SHIP TO	
ENVIRONMENTAL PROTECTION REAP OFFICE 601 57TH ST SE CHARLESTON WV25304 US		ENVIRONMENTAL PROTECTION REAP OFFICE 601 57TH ST SE CHARLESTON WV 25304 US	

Line	Comm Ln Desc	Qty	Unit Issue	Unit Price	Total Price
1	Hydraulic Compact Track Excavator with Attachments	1.00000	EA	\$43,999.00	\$43,999.00

Comm Code	Manufacturer	Specification	Model #
30190000	New Holland	meets specs	E37CAB

Extended Description :

Hydraulic Compact Track Excavator with Attachments, as listed in attached specifications.

SOLICITATION NUMBER: CRFQ 0313 DEP2000000019

Addendum Number: No.01

The purpose of this addendum is to modify the solicitation identified as ("Solicitation") to reflect the change(s) identified and described below.

Applicable Addendum Category:

- | Modify bid opening date and time
- | Modify specifications of product or service being sought
- | Attachment of vendor questions and responses
- | Attachment of pre-bid sign-in sheet
- | Correction of error
- | Other

Description of Modification to Solicitation:

Addendum issued to publish and distribute the attached documentation to the vendor community.

1. Issue and publish Vendor submitted questions and Agency responses.

No other Changes.

Additional Documentation: Documentation related to this Addendum (if any) has been included herewith as Attachment A and is specifically incorporated herein by reference.

Terms and Conditions:

1. All provisions of the Solicitation and other addenda not modified herein shall remain in full force and effect.
2. Vendor should acknowledge receipt of all addenda issued for this Solicitation by completing an Addendum Acknowledgment, a copy of which is included herewith. Failure to acknowledge addenda may result in bid disqualification. The addendum acknowledgement should be submitted with the bid to expedite document processing.

ATTACHMENT A

CRFQ DEP 0313 DEP2000000019

**Hydraulic Compact Track Excavator w/Attachments
Vendor submitted Questions and Agency Responses
January 23rd, 2020 at 9:00 AM. ET.**

1. Q. 3.1.4.2 – Unit shall be equipped with a factory installed hydraulic thumb. My machine comes with thumb ready installation but thumb is installed by dealer – is that acceptable?
A. **Yes, as long as the thumb is manufacturer approved and covered by warranty**
2. Q. 3.1.6.15 – Shall have cab mirrors – Do the mirrors need to be inside or outside?
A. **Either are acceptable**
3. Q. 3.1.6.9 Cab shall have motion alarm with cancel switch. Question: Are you referring to a travel alarm?
A. **Yes**
4. Q. 3.1.6.14 Cab shall be wired for smart link capabilities. Question: what are you referring to as smart link capabilities?
A. **Machine must be able to link to computer, to diagnose problems**
5. Q. Do you anticipate extending the bid due date?
A. **No**
6. Q. What additional details are you willing to provide, if any, beyond what is stated in bid documents concerning how you will identify the winning bid?
A. **Specifications, Terms and Conditions and any and all Addendum issued will make up the bid documents and eventual award documents.**
7. Q. Was this bid posted to the nationwide free bid notification website at www.mygovwatch.com?
A. **No**

8. Q. Other than your own website, where was this bid posted?
- A. **We did not post on any other website. With that being said, we have no idea who may have reposted under a different website.**
9. Q. 3.1.1 Is this excavator to be the zero-tail swing design?
- A. **Yes**
10. Q. 3.1.1.1 A blade is mentioned in the weights section. However I don't see a description of a blade. Do you want a straight blade or an angle blade?
- A. **Straight**
11. Q. 3.1.6.13 The spec calls for a rear secondary exit. We have side and front secondary exits. Is this acceptable?
- A. **Yes, it just needs two exits**
12. Q. 3.1.9 The spec calls for a 16" to 20" bucket. Is 22" acceptable?
- A. **Yes**
- Section 3.1.9.1 of the specifications should now read: Unit shall include a minimum 16-inch maximum 22-inch digging bucket with replaceable teeth.**

ADDENDUM ACKNOWLEDGEMENT FORM
SOLICITATION NO.: _____

Instructions: Please acknowledge receipt of all addenda issued with this solicitation by completing this addendum acknowledgment form. Check the box next to each addendum received and sign below. Failure to acknowledge addenda may result in bid disqualification.

Acknowledgment: I hereby acknowledge receipt of the following addenda and have made the necessary revisions to my proposal, plans and/or specification, etc.

Addendum Numbers Received:

(Check the box next to each addendum received)

- | | |
|--|--|
| <input checked="" type="checkbox"/> Addendum No. 1 | <input type="checkbox"/> Addendum No. 6 |
| <input type="checkbox"/> Addendum No. 2 | <input type="checkbox"/> Addendum No. 7 |
| <input type="checkbox"/> Addendum No. 3 | <input type="checkbox"/> Addendum No. 8 |
| <input type="checkbox"/> Addendum No. 4 | <input type="checkbox"/> Addendum No. 9 |
| <input type="checkbox"/> Addendum No. 5 | <input type="checkbox"/> Addendum No. 10 |

I understand that failure to confirm the receipt of addenda may be cause for rejection of this bid. I further understand that any verbal representation made or assumed to be made during any oral discussion held between Vendor's representatives and any state personnel is not binding. Only the information issued in writing and added to the specifications by an official addendum is binding.

The Tractor Guys LLC

Company



Authorized Signature

1/31/20

Date

NOTE: This addendum acknowledgement should be submitted with the bid to expedite document processing.
Revised 6/8/2012

State of West Virginia
VENDOR PREFERENCE CERTIFICATE

Certification and application is hereby made for Preference in accordance with **West Virginia Code**, §5A-3-37. (Does not apply to construction contracts). **West Virginia Code**, §5A-3-37, provides an opportunity for qualifying vendors to request (at the time of bid) preference for their residency status. Such preference is an evaluation method only and will be applied only to the cost bid in accordance with the **West Virginia Code**. This certificate for application is to be used to request such preference. The Purchasing Division will make the determination of the Vendor Preference, if applicable.

1. **Application is made for 2.5% vendor preference for the reason checked:**
 Bidder is an individual resident vendor and has resided continuously in West Virginia, or bidder is a partnership, association or corporation resident vendor and has maintained its headquarters or principal place of business continuously in West Virginia, for four (4) years immediately preceding the date of this certification; **or**,
 Bidder is a resident vendor partnership, association, or corporation with at least eighty percent of ownership interest of bidder held by another entity that meets the applicable four year residency requirement; **or**,
 Bidder is a nonresident vendor which has an affiliate or subsidiary which employs a minimum of one hundred state residents and which has maintained its headquarters or principal place of business within West Virginia continuously for the four (4) years immediately preceding the date of this certification; **or**,
2. **Application is made for 2.5% vendor preference for the reason checked:**
 Bidder is a resident vendor who certifies that, during the life of the contract, on average at least 75% of the employees working on the project being bid are residents of West Virginia who have resided in the state continuously for the two years immediately preceding submission of this bid; **or**,
3. **Application is made for 2.5% vendor preference for the reason checked:**
 Bidder is a nonresident vendor that employs a minimum of one hundred state residents, or a nonresident vendor which has an affiliate or subsidiary which maintains its headquarters or principal place of business within West Virginia and employs a minimum of one hundred state residents, and for purposes of producing or distributing the commodities or completing the project which is the subject of the bidder's bid and continuously over the entire term of the project, on average at least seventy-five percent of the bidder's employees or the bidder's affiliate's or subsidiary's employees are residents of West Virginia who have resided in the state continuously for the two immediately preceding years and the vendor's bid; **or**,
4. **Application is made for 5% vendor preference for the reason checked:**
 Bidder meets either the requirement of both subdivisions (1) and (2) or subdivision (1) and (3) as stated above; **or**,
5. **Application is made for 3.5% vendor preference who is a veteran for the reason checked:**
 Bidder is an individual resident vendor who is a veteran of the United States armed forces, the reserves or the National Guard and has resided in West Virginia continuously for the four years immediately preceding the date on which the bid is submitted; **or**,
6. **Application is made for 3.5% vendor preference who is a veteran for the reason checked:**
 Bidder is a resident vendor who is a veteran of the United States armed forces, the reserves or the National Guard, if, for purposes of producing or distributing the commodities or completing the project which is the subject of the vendor's bid and continuously over the entire term of the project, on average at least seventy-five percent of the vendor's employees are residents of West Virginia who have resided in the state continuously for the two immediately preceding years.
7. **Application is made for preference as a non-resident small, women- and minority-owned business, in accordance with West Virginia Code §5A-3-59 and West Virginia Code of State Rules.**
 Bidder has been or expects to be approved prior to contract award by the Purchasing Division as a certified small, women- and minority-owned business.
8. **Application is made for reciprocal preference.**
 Bidder is a West Virginia resident and is requesting reciprocal preference to the extent that it applies.

Bidder understands if the Secretary of Revenue determines that a Bidder receiving preference has failed to continue to meet the requirements for such preference, the Secretary may order the Director of Purchasing to: (a) rescind the contract or purchase order; or (b) assess a penalty against such Bidder in an amount not to exceed 5% of the bid amount and that such penalty will be paid to the contracting agency or deducted from any unpaid balance on the contract or purchase order.

By submission of this certificate, Bidder agrees to disclose any reasonably requested information to the Purchasing Division and authorizes the Department of Revenue to disclose to the Director of Purchasing appropriate information verifying that Bidder has paid the required business taxes, provided that such information does not contain the amounts of taxes paid nor any other information deemed by the Tax Commissioner to be confidential.

Bidder hereby certifies that this certificate is true and accurate in all respects; and that if a contract is issued to Bidder and if anything contained within this certificate changes during the term of the contract, Bidder will notify the Purchasing Division in writing immediately.

Bidder: THE TRACTOR GUYS LLC

Signed: 

Date: 1/31/20

Title: CHIEF OPERATING OFFICER

*Check any combination of preference consideration(s) indicated above, which you are entitled to receive.



Purchasing Division
 2019 Washington Street East
 Post Office Box 50130
 Charleston, WV 25305-0130

State of West Virginia
 Request for Quotation
 13 - Equipment

Proc Folder: 677055

Doc Description: Hydraulic Compact Track Excavator with Attachments

Proc Type: Central Purchase Order

Date Issued	Solicitation Closes	Solicitation No	Version
2020-01-16	2020-01-31 13:30:00	CRFQ 0313 DEP2000000019	1

BID RECEIVING LOCATION

BID CLERK
 DEPARTMENT OF ADMINISTRATION
 PURCHASING DIVISION
 2019 WASHINGTON ST E
 CHARLESTON WV 25305
 US

VENDOR

Vendor Name, Address and Telephone Number:

The Tractor Guys LLC
 87 wiseman run road
 Salem wv 26426
 304-615-6340

FOR INFORMATION CONTACT THE BUYER

Guy Nisbet
 (304) 558-2596
 guy.l.nisbet@wv.gov

Signature X Patrick Holguin

FEIN # 27-0951894

DATE 1/31/20

All offers subject to all terms and conditions contained in this solicitation

ADDITIONAL INFORMATION

Request for Quotation
 (Hydraulic compact Tract Excavator w/Attachments)

The West Virginia Purchasing Division is soliciting bids on behalf of the West Virginia Department of Environmental Protection (WVDEP), Rehabilitation Environmental Action Plan (REAP), to establish a contract for the one-time purchase of one (1) Hydraulic Compact Track Excavator and the associated listed attachments for the same, per the bid requirements, specifications, terms and conditions as attached hereto.

INVOICE TO		SHIP TO	
ENVIRONMENTAL PROTECTION REAP OFFICE 601 57TH ST SE CHARLESTON WV25304 US		ENVIRONMENTAL PROTECTION REAP OFFICE 601 57TH ST SE CHARLESTON WV 25304 US	

Line	Comm Ln Desc	Qty	Unit Issue	Unit Price	Total Price
1	Hydraulic Compact Track Excavator with Attachments	1.00000	EA	\$43,999.00	\$43,999.00

Comm Code	Manufacturer	Specification	Model #
30190000	New Holland	meets specs	E37CAB

Extended Description :
 Hydraulic Compact Track Excavator with Attachments, as listed in attached specifications.

INSTRUCTIONS TO VENDORS SUBMITTING BIDS

1. REVIEW DOCUMENTS THOROUGHLY: The attached documents contain a solicitation for bids. Please read these instructions and all documents attached in their entirety. These instructions provide critical information about requirements that if overlooked could lead to disqualification of a Vendor's bid. All bids must be submitted in accordance with the provisions contained in these instructions and the Solicitation. Failure to do so may result in disqualification of Vendor's bid.

2. MANDATORY TERMS: The Solicitation may contain mandatory provisions identified by the use of the words "must," "will," and "shall." Failure to comply with a mandatory term in the Solicitation will result in bid disqualification.

3. PREBID MEETING: The item identified below shall apply to this Solicitation.

A pre-bid meeting will not be held prior to bid opening

A MANDATORY PRE-BID meeting will be held at the following place and time:

All Vendors submitting a bid must attend the mandatory pre-bid meeting. Failure to attend the mandatory pre-bid meeting shall result in disqualification of the Vendor's bid. No one individual is permitted to represent more than one vendor at the pre-bid meeting. Any individual that does attempt to represent two or more vendors will be required to select one vendor to which the individual's attendance will be attributed. The vendors not selected will be deemed to have not attended the pre-bid meeting unless another individual attended on their behalf.

An attendance sheet provided at the pre-bid meeting shall serve as the official document verifying attendance. Any person attending the pre-bid meeting on behalf of a Vendor must list on the attendance sheet his or her name and the name of the Vendor he or she is representing.

Additionally, the person attending the pre-bid meeting should include the Vendor's E-Mail address, phone number, and Fax number on the attendance sheet. It is the Vendor's responsibility to locate the attendance sheet and provide the required information. Failure to complete the attendance sheet as required may result in disqualification of Vendor's bid.

All Vendors should arrive prior to the starting time for the pre-bid. Vendors who arrive after the starting time but prior to the end of the pre-bid will be permitted to sign in but are charged with knowing all matters discussed at the pre-bid.

Questions submitted at least five business days prior to a scheduled pre-bid will be discussed at the pre-bid meeting if possible. Any discussions or answers to questions at the pre-bid meeting
Revised 01/09/2020

are preliminary in nature and are non-binding. Official and binding answers to questions will be published in a written addendum to the Solicitation prior to bid opening.

4. VENDOR QUESTION DEADLINE: Vendors may submit questions relating to this Solicitation to the Purchasing Division. Questions must be submitted in writing. All questions must be submitted on or before the date listed below and to the address listed below in order to be considered. A written response will be published in a Solicitation addendum if a response is possible and appropriate. Non-written discussions, conversations, or questions and answers regarding this Solicitation are preliminary in nature and are nonbinding.

Submitted e-mails should have solicitation number in the subject line.

Question Submission Deadline: 01/23/2020 at 9:00 AM. ET.

Submit Questions to: Guy Nisbet
 2019 Washington Street, East
 Charleston, WV 25305
 Fax: (304) 558-4115 (Vendors should not use this fax number for bid submission)
 Email: Guy.L.Nisbet@WV.Gov

5. VERBAL COMMUNICATION: Any verbal communication between the Vendor and any State personnel is not binding, including verbal communication at the mandatory pre-bid conference. Only information issued in writing and added to the Solicitation by an official written addendum by the Purchasing Division is binding.

6. BID SUBMISSION: All bids must be submitted electronically through wvOASIS or signed and delivered by the Vendor to the Purchasing Division at the address listed below on or before the date and time of the bid opening. Any bid received by the Purchasing Division staff is considered to be in the possession of the Purchasing Division and will not be returned for any reason. The Purchasing Division will not accept bids, modification of bids, or addendum acknowledgment forms via e-mail. Acceptable delivery methods include electronic submission via wvOASIS, hand delivery, delivery by courier, or facsimile.

The bid delivery address is:
 Department of Administration, Purchasing Division
 2019 Washington Street East
 Charleston, WV 25305-0130

A bid that is not submitted electronically through wvOASIS should contain the information listed below on the face of the envelope or the bid may be rejected by the Purchasing Division.:

SEALED BID:	DEP Compact Track Excavator w/attachments
BUYER:	Guy Nisbet
SOLICITATION NO.:	
BID OPENING DATE:	
BID OPENING TIME:	1:30 PM. ET.
FAX NUMBER:	304.558.3970

Revised 01/09/2020

The Purchasing Division may prohibit the submission of bids electronically through wvOASIS at its sole discretion. Such a prohibition will be contained and communicated in the wvOASIS system resulting in the Vendor's inability to submit bids through wvOASIS. Submission of a response to an Expression or Interest or Request for Proposal is not permitted in wvOASIS.

For Request For Proposal ("RFP") Responses Only: In the event that Vendor is responding to a request for proposal, the Vendor shall submit one original technical and one original cost proposal plus N/A convenience copies of each to the Purchasing Division at the address shown above. Additionally, the Vendor should identify the bid type as either a technical or cost proposal on the face of each bid envelope submitted in response to a request for proposal as follows:

BID TYPE: (This only applies to CRFP)

Technical

Cost

7. BID OPENING: Bids submitted in response to this Solicitation will be opened at the location identified below on the date and time listed below. Delivery of a bid after the bid opening date and time will result in bid disqualification. For purposes of this Solicitation, a bid is considered delivered when confirmation of delivery is provided by wvOASIS (in the case of electronic submission) or when the bid is time stamped by the official Purchasing Division time clock (in the case of hand delivery).

Bid Opening Date and Time: 01/31/2020 at 1:30 PM. ET.

Bid Opening Location: Department of Administration, Purchasing Division
2019 Washington Street East
Charleston, WV 25305-0130

8. ADDENDUM ACKNOWLEDGEMENT: Changes or revisions to this Solicitation will be made by an official written addendum issued by the Purchasing Division. Vendor should acknowledge receipt of all addenda issued with this Solicitation by completing an Addendum Acknowledgment Form, a copy of which is included herewith. Failure to acknowledge addenda may result in bid disqualification. The addendum acknowledgement should be submitted with the bid to expedite document processing.

9. BID FORMATTING: Vendor should type or electronically enter the information onto its bid to prevent errors in the evaluation. Failure to type or electronically enter the information may result in bid disqualification.

10. ALTERNATE MODEL OR BRAND: Unless the box below is checked, any model, brand, or specification listed in this Solicitation establishes the acceptable level of quality only and is not intended to reflect a preference for, or in any way favor, a particular brand or vendor. Vendors may bid alternates to a listed model or brand provided that the alternate is at least equal to the model or brand and complies with the required specifications. The equality of any alternate being bid shall be determined by the State at its sole discretion. Any Vendor bidding an alternate model or brand should clearly identify the alternate items in its bid and should include manufacturer's specifications, industry literature, and/or any other relevant documentation demonstrating the

equality of the alternate items. Failure to provide information for alternate items may be grounds for rejection of a Vendor's bid.

This Solicitation is based upon a standardized commodity established under W. Va. Code § 5A-3-61. Vendors are expected to bid the standardized commodity identified. Failure to bid the standardized commodity will result in your firm's bid being rejected.

11. EXCEPTIONS AND CLARIFICATIONS: The Solicitation contains the specifications that shall form the basis of a contractual agreement. Vendor shall clearly mark any exceptions, clarifications, or other proposed modifications in its bid. Exceptions to, clarifications of, or modifications of a requirement or term and condition of the Solicitation may result in bid disqualification.

12. COMMUNICATION LIMITATIONS: In accordance with West Virginia Code of State Rules §148-1-6.6, communication with the State of West Virginia or any of its employees regarding this Solicitation during the solicitation, bid, evaluation or award periods, except through the Purchasing Division, is strictly prohibited without prior Purchasing Division approval. Purchasing Division approval for such communication is implied for all agency delegated and exempt purchases.

13. REGISTRATION: Prior to Contract award, the apparent successful Vendor must be properly registered with the West Virginia Purchasing Division and must have paid the \$125 fee, if applicable.

14. UNIT PRICE: Unit prices shall prevail in cases of a discrepancy in the Vendor's bid.

15. PREFERENCE: Vendor Preference may be requested in purchases of motor vehicles or construction and maintenance equipment and machinery used in highway and other infrastructure projects. Any request for preference must be submitted in writing with the bid, must specifically identify the preference requested with reference to the applicable subsection of West Virginia Code § 5A-3-37, and must include with the bid any information necessary to evaluate and confirm the applicability of the requested preference. A request form to help facilitate the request can be found at:

<http://www.state.wv.us/admin/purchase/vrc/Venpref.pdf>.

15A. RECIPROCAL PREFERENCE: The State of West Virginia applies a reciprocal preference to all solicitations for commodities and printing in accordance with W. Va. Code § 5A-3-37(b). In effect, non-resident vendors receiving a preference in their home states, will see that same preference granted to West Virginia resident vendors bidding against them in West Virginia. Any request for reciprocal preference must include with the bid any information necessary to evaluate and confirm the applicability of the preference. A request form to help facilitate the request can be found at: <http://www.state.wv.us/admin/purchase/vrc/Venpref.pdf>.

16. SMALL, WOMEN-OWNED, OR MINORITY-OWNED BUSINESSES: For any solicitations publicly advertised for bid, in accordance with West Virginia Code §5A-3-37(a)(7) and W. Va. CSR § 148-22-9, any non-resident vendor certified as a small, women-owned, or minority-owned business under W. Va. CSR § 148-22-9 shall be provided the same preference made available to any resident vendor. Any non-resident small, women-owned, or

minority-owned business must identify itself as such in writing, must submit that writing to the Purchasing Division with its bid, and must be properly certified under W. Va. CSR § 148-22-9 prior to contract award to receive the preferences made available to resident vendors. Preference for a non-resident small, women-owned, or minority owned business shall be applied in accordance with W. Va. CSR § 148-22-9.

17. WAIVER OF MINOR IRREGULARITIES: The Director reserves the right to waive minor irregularities in bids or specifications in accordance with West Virginia Code of State Rules § 148-1-4.6.

18. ELECTRONIC FILE ACCESS RESTRICTIONS: Vendor must ensure that its submission in wvOASIS can be accessed and viewed by the Purchasing Division staff immediately upon bid opening. The Purchasing Division will consider any file that cannot be immediately accessed and viewed at the time of the bid opening (such as, encrypted files, password protected files, or incompatible files) to be blank or incomplete as context requires, and are therefore unacceptable. A vendor will not be permitted to unencrypt files, remove password protections, or resubmit documents after bid opening to make a file viewable if those documents are required with the bid. A Vendor may be required to provide document passwords or remove access restrictions to allow the Purchasing Division to print or electronically save documents provided that those documents are viewable by the Purchasing Division prior to obtaining the password or removing the access restriction.

19. NON-RESPONSIBLE: The Purchasing Division Director reserves the right to reject the bid of any vendor as Non-Responsible in accordance with W. Va. Code of State Rules § 148-1-5.3, when the Director determines that the vendor submitting the bid does not have the capability to fully perform, or lacks the integrity and reliability to assure good-faith performance.”

20. ACCEPTANCE/REJECTION: The State may accept or reject any bid in whole, or in part in accordance with W. Va. Code of State Rules § 148-1-4.5. and § 148-1-6.4.b.”

21. YOUR SUBMISSION IS A PUBLIC DOCUMENT: Vendor’s entire response to the Solicitation and the resulting Contract are public documents. As public documents, they will be disclosed to the public following the bid/proposal opening or award of the contract, as required by the competitive bidding laws of West Virginia Code §§ 5A-3-1 et seq., 5-22-1 et seq., and 5G-1-1 et seq. and the Freedom of Information Act West Virginia Code §§ 29B-1-1 et seq.

DO NOT SUBMIT MATERIAL YOU CONSIDER TO BE CONFIDENTIAL, A TRADE SECRET, OR OTHERWISE NOT SUBJECT TO PUBLIC DISCLOSURE.

Submission of any bid, proposal, or other document to the Purchasing Division constitutes your explicit consent to the subsequent public disclosure of the bid, proposal, or document. The Purchasing Division will disclose any document labeled “confidential,” “proprietary,” “trade secret,” “private,” or labeled with any other claim against public disclosure of the documents, to include any “trade secrets” as defined by West Virginia Code § 47-22-1 et seq. All submissions are subject to public disclosure without notice.

22. INTERESTED PARTY DISCLOSURE: West Virginia Code § 6D-1-2 requires that the vendor submit to the Purchasing Division a disclosure of interested parties to the contract for all contracts with an actual or estimated value of at least \$1 Million. That disclosure must occur on the form prescribed and approved by the WV Ethics Commission prior to contract award. A copy of that form is included with this solicitation or can be obtained from the WV Ethics Commission. This requirement does not apply to publicly traded companies listed on a national or international stock exchange. A more detailed definition of interested parties can be obtained from the form referenced above.

23. WITH THE BID REQUIREMENTS: In instances where these specifications require documentation or other information with the bid, and a vendor fails to provide it with the bid, the Director of the Purchasing Division reserves the right to request those items after bid opening and prior to contract award pursuant to the authority to waive minor irregularities in bids or specifications under W. Va. CSR § 148-1-4.6. This authority does not apply to instances where state law mandates receipt with the bid.

GENERAL TERMS AND CONDITIONS:

1. CONTRACTUAL AGREEMENT: Issuance of a Award Document signed by the Purchasing Division Director, or his designee, and approved as to form by the Attorney General's office constitutes acceptance of this Contract made by and between the State of West Virginia and the Vendor. Vendor's signature on its bid signifies Vendor's agreement to be bound by and accept the terms and conditions contained in this Contract.

2. DEFINITIONS: As used in this Solicitation/Contract, the following terms shall have the meanings attributed to them below. Additional definitions may be found in the specifications included with this Solicitation/Contract.

2.1. "Agency" or "Agencies" means the agency, board, commission, or other entity of the State of West Virginia that is identified on the first page of the Solicitation or any other public entity seeking to procure goods or services under this Contract.

2.2. "Bid" or "Proposal" means the vendors submitted response to this solicitation.

2.3. "Contract" means the binding agreement that is entered into between the State and the Vendor to provide the goods or services requested in the Solicitation.

2.4. "Director" means the Director of the West Virginia Department of Administration, Purchasing Division.

2.5. "Purchasing Division" means the West Virginia Department of Administration, Purchasing Division.

2.6. "Award Document" means the document signed by the Agency and the Purchasing Division, and approved as to form by the Attorney General, that identifies the Vendor as the contract holder.

2.7. "Solicitation" means the official notice of an opportunity to supply the State with goods or services that is published by the Purchasing Division.

2.8. "State" means the State of West Virginia and/or any of its agencies, commissions, boards, etc. as context requires.

2.9. "Vendor" or "Vendors" means any entity submitting a bid in response to the Solicitation, the entity that has been selected as the lowest responsible bidder, or the entity that has been awarded the Contract as context requires.

3. CONTRACT TERM; RENEWAL; EXTENSION: The term of this Contract shall be determined in accordance with the category that has been identified as applicable to this Contract below:

Term Contract

Initial Contract Term: **Initial Contract Term:** This Contract becomes effective on _____ and extends for a period of _____ year(s).

Renewal Term: This Contract may be renewed upon the mutual written consent of the Agency, and the Vendor, with approval of the Purchasing Division and the Attorney General’s office (Attorney General approval is as to form only). Any request for renewal should be delivered to the Agency and then submitted to the Purchasing Division thirty (30) days prior to the expiration date of the initial contract term or appropriate renewal term. A Contract renewal shall be in accordance with the terms and conditions of the original contract. Unless otherwise specified below, renewal of this Contract is limited to _____ successive one (1) year periods or multiple renewal periods of less than one year, provided that the multiple renewal periods do not exceed the total number of months available in all renewal years combined. Automatic renewal of this Contract is prohibited. Renewals must be approved by the Vendor, Agency, Purchasing Division and Attorney General’s office (Attorney General approval is as to form only)

Alternate Renewal Term – This contract may be renewed for _____ successive _____ year periods or shorter periods provided that they do not exceed the total number of months contained in all available renewals. Automatic renewal of this Contract is prohibited. Renewals must be approved by the Vendor, Agency, Purchasing Division and Attorney General’s office (Attorney General approval is as to form only)

Delivery Order Limitations: In the event that this contract permits delivery orders, a delivery order may only be issued during the time this Contract is in effect. Any delivery order issued within one year of the expiration of this Contract shall be effective for one year from the date the delivery order is issued. No delivery order may be extended beyond one year after this Contract has expired.

Fixed Period Contract: This Contract becomes effective upon Vendor’s receipt of the notice to proceed and must be completed within _____ days.

Fixed Period Contract with Renewals: This Contract becomes effective upon Vendor’s receipt of the notice to proceed and part of the Contract more fully described in the attached specifications must be completed within _____ days. Upon completion of the work covered by the preceding sentence, the vendor agrees that maintenance, monitoring, or warranty services will be provided for _____ year(s) thereafter.

One Time Purchase: The term of this Contract shall run from the issuance of the Award Document until all of the goods contracted for have been delivered, but in no event will this Contract extend for more than one fiscal year.

Other: See attached.

4. NOTICE TO PROCEED: Vendor shall begin performance of this Contract immediately upon receiving notice to proceed unless otherwise instructed by the Agency. Unless otherwise specified, the fully executed Award Document will be considered notice to proceed.

5. QUANTITIES: The quantities required under this Contract shall be determined in accordance with the category that has been identified as applicable to this Contract below.

Open End Contract: Quantities listed in this Solicitation are approximations only, based on estimates supplied by the Agency. It is understood and agreed that the Contract shall cover the quantities actually ordered for delivery during the term of the Contract, whether more or less than the quantities shown.

Service: The scope of the service to be provided will be more clearly defined in the specifications included herewith.

Combined Service and Goods: The scope of the service and deliverable goods to be provided will be more clearly defined in the specifications included herewith.

One Time Purchase: This Contract is for the purchase of a set quantity of goods that are identified in the specifications included herewith. Once those items have been delivered, no additional goods may be procured under this Contract without an appropriate change order approved by the Vendor, Agency, Purchasing Division, and Attorney General's office.

6. EMERGENCY PURCHASES: The Purchasing Division Director may authorize the Agency to purchase goods or services in the open market that Vendor would otherwise provide under this Contract if those goods or services are for immediate or expedited delivery in an emergency. Emergencies shall include, but are not limited to, delays in transportation or an unanticipated increase in the volume of work. An emergency purchase in the open market, approved by the Purchasing Division Director, shall not constitute of breach of this Contract and shall not entitle the Vendor to any form of compensation or damages. This provision does not excuse the State from fulfilling its obligations under a One Time Purchase contract.

7. REQUIRED DOCUMENTS: All of the items checked below must be provided to the Purchasing Division by the Vendor as specified below.

BID BOND (Construction Only): Pursuant to the requirements contained in W. Va. Code § 5-22-1(c), All Vendors submitting a bid on a construction project shall furnish a valid bid bond in the amount of five percent (5%) of the total amount of the bid protecting the State of West Virginia. The bid bond must be submitted with the bid.

PERFORMANCE BOND: The apparent successful Vendor shall provide a performance bond in the amount of 100% of the contract. The performance bond must be received by the Purchasing Division prior to Contract award.

LABOR/MATERIAL PAYMENT BOND: The apparent successful Vendor shall provide a labor/material payment bond in the amount of 100% of the Contract value. The labor/material payment bond must be delivered to the Purchasing Division prior to Contract award.

In lieu of the Bid Bond, Performance Bond, and Labor/Material Payment Bond, the Vendor may provide certified checks, cashier's checks, or irrevocable letters of credit. Any certified check, cashier's check, or irrevocable letter of credit provided in lieu of a bond must be of the same amount and delivered on the same schedule as the bond it replaces. A letter of credit submitted in lieu of a performance and labor/material payment bond will only be allowed for projects under \$100,000. Personal or business checks are not acceptable. Notwithstanding the foregoing, West Virginia Code § 5-22-1 (d) mandates that a vendor provide a performance and labor/material payment bond for construction projects. Accordingly, substitutions for the performance and labor/material payment bonds for construction projects is not permitted.

MAINTENANCE BOND: The apparent successful Vendor shall provide a two (2) year maintenance bond covering the roofing system. The maintenance bond must be issued and delivered to the Purchasing Division prior to Contract award.

LICENSE(S) / CERTIFICATIONS / PERMITS: In addition to anything required under the Section of the General Terms and Conditions entitled Licensing, the apparent successful Vendor shall furnish proof of the following licenses, certifications, and/or permits upon request and in a form acceptable to the State. The request may be prior to or after contract award at the State's sole discretion.

The apparent successful Vendor shall also furnish proof of any additional licenses or certifications contained in the specifications regardless of whether or not that requirement is listed above.

8. INSURANCE: The apparent successful Vendor shall furnish proof of the insurance identified by a checkmark below and must include the State as an additional insured on each policy prior to Contract award. The insurance coverages identified below must be maintained throughout the life of this contract. Thirty (30) days prior to the expiration of the insurance policies, Vendor shall provide the Agency with proof that the insurance mandated herein has been continued. Vendor must also provide Agency with immediate notice of any changes in its insurance policies, including but not limited to, policy cancelation, policy reduction, or change in insurers. The apparent successful Vendor shall also furnish proof of any additional insurance requirements contained in the specifications prior to Contract award regardless of whether or not that insurance requirement is listed in this section.

Vendor must maintain:

Commercial General Liability Insurance in at least an amount of: \$1,000,000.00 per occurrence.

Automobile Liability Insurance in at least an amount of: \$1,000,000.00 per occurrence.

Professional/Malpractice/Errors and Omission Insurance in at least an amount of: _____ per occurrence. Notwithstanding the forgoing, Vendor's are not required to list the State as an additional insured for this type of policy.

Commercial Crime and Third Party Fidelity Insurance in an amount of: _____ per occurrence.

Cyber Liability Insurance in an amount of: _____ per occurrence.

Builders Risk Insurance in an amount equal to 100% of the amount of the Contract.

Pollution Insurance in an amount of: _____ per occurrence.

Aircraft Liability in an amount of: _____ per occurrence.

Notwithstanding anything contained in this section to the contrary, the Director of the Purchasing Division reserves the right to waive the requirement that the State be named as an additional insured on one or more of the Vendor's insurance policies if the Director finds that doing so is in the State's best interest.

9. WORKERS' COMPENSATION INSURANCE: The apparent successful Vendor shall comply with laws relating to workers compensation, shall maintain workers' compensation insurance when required, and shall furnish proof of workers' compensation insurance upon request.

10. [Reserved]

11. LIQUIDATED DAMAGES: This clause shall in no way be considered exclusive and shall not limit the State or Agency's right to pursue any other available remedy. Vendor shall pay liquidated damages in the amount specified below or as described in the specifications:

_____ for _____

Liquidated Damages Contained in the Specifications

12. ACCEPTANCE: Vendor's signature on its bid, or on the certification and signature page, constitutes an offer to the State that cannot be unilaterally withdrawn, signifies that the product or service proposed by vendor meets the mandatory requirements contained in the Solicitation for that product or service, unless otherwise indicated, and signifies acceptance of the terms and conditions contained in the Solicitation unless otherwise indicated.

13. PRICING: The pricing set forth herein is firm for the life of the Contract, unless specified elsewhere within this Solicitation/Contract by the State. A Vendor's inclusion of price adjustment provisions in its bid, without an express authorization from the State in the Solicitation to do so, may result in bid disqualification. Notwithstanding the foregoing, Vendor must extend any publicly advertised sale price to the State and invoice at the lower of the contract price or the publicly advertised sale price.

14. PAYMENT IN ARREARS: Payment in advance is prohibited under this Contract. Payment may only be made after the delivery and acceptance of goods or services. The Vendor shall submit invoices, in arrears.

15. PAYMENT METHODS: Vendor must accept payment by electronic funds transfer and P-Card. (The State of West Virginia's Purchasing Card program, administered under contract by a banking institution, processes payment for goods and services through state designated credit cards.)

16. TAXES: The Vendor shall pay any applicable sales, use, personal property or any other taxes arising out of this Contract and the transactions contemplated thereby. The State of West Virginia is exempt from federal and state taxes and will not pay or reimburse such taxes.

17. ADDITIONAL FEES: Vendor is not permitted to charge additional fees or assess additional charges that were not either expressly provided for in the solicitation published by the State of West Virginia or included in the unit price or lump sum bid amount that Vendor is required by the solicitation to provide. Including such fees or charges as notes to the solicitation may result in rejection of vendor's bid. Requesting such fees or charges be paid after the contract has been awarded may result in cancellation of the contract.

18. FUNDING: This Contract shall continue for the term stated herein, contingent upon funds being appropriated by the Legislature or otherwise being made available. In the event funds are not appropriated or otherwise made available, this Contract becomes void and of no effect beginning on July 1 of the fiscal year for which funding has not been appropriated or otherwise made available.

19. CANCELLATION: The Purchasing Division Director reserves the right to cancel this Contract immediately upon written notice to the vendor if the materials or workmanship supplied do not conform to the specifications contained in the Contract. The Purchasing Division Director may also cancel any purchase or Contract upon 30 days written notice to the Vendor in accordance with West Virginia Code of State Rules § 148-1-5.2.b.

20. TIME: Time is of the essence with regard to all matters of time and performance in this Contract.

21. APPLICABLE LAW: This Contract is governed by and interpreted under West Virginia law without giving effect to its choice of law principles. Any information provided in specification manuals, or any other source, verbal or written, which contradicts or violates the West Virginia Constitution, West Virginia Code or West Virginia Code of State Rules is void and of no effect.

22. COMPLIANCE WITH LAWS: Vendor shall comply with all applicable federal, state, and local laws, regulations and ordinances. By submitting a bid, Vendor acknowledges that it has reviewed, understands, and will comply with all applicable laws, regulations, and ordinances.

SUBCONTRACTOR COMPLIANCE: Vendor shall notify all subcontractors providing commodities or services related to this Contract that as subcontractors, they too are required to comply with all applicable laws, regulations, and ordinances. Notification under this provision must occur prior to the performance of any work under the contract by the subcontractor.

23. ARBITRATION: Any references made to arbitration contained in this Contract, Vendor's bid, or in any American Institute of Architects documents pertaining to this Contract are hereby deleted, void, and of no effect.

24. MODIFICATIONS: This writing is the parties' final expression of intent. Notwithstanding anything contained in this Contract to the contrary no modification of this Contract shall be binding without mutual written consent of the Agency, and the Vendor, with approval of the Purchasing Division and the Attorney General's office (Attorney General approval is as to form only). Any change to existing contracts that adds work or changes contract cost, and were not included in the original contract, must be approved by the Purchasing Division and the Attorney General's Office (as to form) prior to the implementation of the change or commencement of work affected by the change.

25. WAIVER: The failure of either party to insist upon a strict performance of any of the terms or provision of this Contract, or to exercise any option, right, or remedy herein contained, shall not be construed as a waiver or a relinquishment for the future of such term, provision, option, right, or remedy, but the same shall continue in full force and effect. Any waiver must be expressly stated in writing and signed by the waiving party.

26. SUBSEQUENT FORMS: The terms and conditions contained in this Contract shall supersede any and all subsequent terms and conditions which may appear on any form documents submitted by Vendor to the Agency or Purchasing Division such as price lists, order forms, invoices, sales agreements, or maintenance agreements, and includes internet websites or other electronic documents. Acceptance or use of Vendor's forms does not constitute acceptance of the terms and conditions contained thereon.

27. ASSIGNMENT: Neither this Contract nor any monies due, or to become due hereunder, may be assigned by the Vendor without the express written consent of the Agency, the Purchasing Division, the Attorney General's office (as to form only), and any other government agency or office that may be required to approve such assignments.

28. WARRANTY: The Vendor expressly warrants that the goods and/or services covered by this Contract will: (a) conform to the specifications, drawings, samples, or other description furnished or specified by the Agency; (b) be merchantable and fit for the purpose intended; and (c) be free from defect in material and workmanship.

29. STATE EMPLOYEES: State employees are not permitted to utilize this Contract for personal use and the Vendor is prohibited from permitting or facilitating the same.

30. PRIVACY, SECURITY, AND CONFIDENTIALITY: The Vendor agrees that it will not disclose to anyone, directly or indirectly, any such personally identifiable information or other confidential information gained from the Agency, unless the individual who is the subject of the information consents to the disclosure in writing or the disclosure is made pursuant to the Agency's policies, procedures, and rules. Vendor further agrees to comply with the Confidentiality Policies and Information Security Accountability Requirements, set forth in <http://www.state.wv.us/admin/purchase/privacy/default.html>.

31. YOUR SUBMISSION IS A PUBLIC DOCUMENT: Vendor's entire response to the Solicitation and the resulting Contract are public documents. As public documents, they will be disclosed to the public following the bid/proposal opening or award of the contract, as required by the competitive bidding laws of West Virginia Code §§ 5A-3-1 et seq., 5-22-1 et seq., and 5G-1-1 et seq. and the Freedom of Information Act West Virginia Code §§ 29B-1-1 et seq.

DO NOT SUBMIT MATERIAL YOU CONSIDER TO BE CONFIDENTIAL, A TRADE SECRET, OR OTHERWISE NOT SUBJECT TO PUBLIC DISCLOSURE.

Submission of any bid, proposal, or other document to the Purchasing Division constitutes your explicit consent to the subsequent public disclosure of the bid, proposal, or document. The Purchasing Division will disclose any document labeled "confidential," "proprietary," "trade secret," "private," or labeled with any other claim against public disclosure of the documents, to include any "trade secrets" as defined by West Virginia Code § 47-22-1 et seq. All submissions are subject to public disclosure without notice.

32. LICENSING: In accordance with West Virginia Code of State Rules § 148-1-6.1.e, Vendor must be licensed and in good standing in accordance with any and all state and local laws and requirements by any state or local agency of West Virginia, including, but not limited to, the West Virginia Secretary of State's Office, the West Virginia Tax Department, West Virginia Insurance Commission, or any other state agency or political subdivision. Obligations related to political subdivisions may include, but are not limited to, business licensing, business and occupation taxes, inspection compliance, permitting, etc. Upon request, the Vendor must provide all necessary releases to obtain information to enable the Purchasing Division Director or the Agency to verify that the Vendor is licensed and in good standing with the above entities.

SUBCONTRACTOR COMPLIANCE: Vendor shall notify all subcontractors providing commodities or services related to this Contract that as subcontractors, they too are required to be licensed, in good standing, and up-to-date on all state and local obligations as described in this section. Obligations related to political subdivisions may include, but are not limited to, business licensing, business and occupation taxes, inspection compliance, permitting, etc. Notification under this provision must occur prior to the performance of any work under the contract by the subcontractor.

33. ANTITRUST: In submitting a bid to, signing a contract with, or accepting a Award Document from any agency of the State of West Virginia, the Vendor agrees to convey, sell, assign, or transfer to the State of West Virginia all rights, title, and interest in and to all causes of action it may now or hereafter acquire under the antitrust laws of the United States and the State of West Virginia for price fixing and/or unreasonable restraints of trade relating to the particular commodities or services purchased or acquired by the State of West Virginia. Such assignment shall be made and become effective at the time the purchasing agency tenders the initial payment to Vendor.

34. VENDOR CERTIFICATIONS: By signing its bid or entering into this Contract, Vendor certifies (1) that its bid or offer was made without prior understanding, agreement, or connection with any corporation, firm, limited liability company, partnership, person or entity submitting a bid or offer for the same material, supplies, equipment or services; (2) that its bid or offer is in all respects fair and without collusion or fraud; (3) that this Contract is accepted or entered into without any prior understanding, agreement, or connection to any other entity that could be considered a violation of law; and (4) that it has reviewed this Solicitation in its entirety; understands the requirements, terms and conditions, and other information contained herein.

Vendor's signature on its bid or offer also affirms that neither it nor its representatives have any interest, nor shall acquire any interest, direct or indirect, which would compromise the performance of its services hereunder. Any such interests shall be promptly presented in detail to the Agency. The individual signing this bid or offer on behalf of Vendor certifies that he or she is authorized by the Vendor to execute this bid or offer or any documents related thereto on Vendor's behalf; that he or she is authorized to bind the Vendor in a contractual relationship; and that, to the best of his or her knowledge, the Vendor has properly registered with any State agency that may require registration.

35. VENDOR RELATIONSHIP: The relationship of the Vendor to the State shall be that of an independent contractor and no principal-agent relationship or employer-employee relationship is contemplated or created by this Contract. The Vendor as an independent contractor is solely liable for the acts and omissions of its employees and agents. Vendor shall be responsible for selecting, supervising, and compensating any and all individuals employed pursuant to the terms of this Solicitation and resulting contract. Neither the Vendor, nor any employees or subcontractors of the Vendor, shall be deemed to be employees of the State for any purpose whatsoever. Vendor shall be exclusively responsible for payment of employees and contractors for all wages and salaries, taxes, withholding payments, penalties, fees, fringe benefits, professional liability insurance premiums, contributions to insurance and pension, or other deferred compensation plans, including but not limited to, Workers' Compensation and Social Security obligations, licensing fees, etc. and the filing of all necessary documents, forms, and returns pertinent to all of the foregoing.

Vendor shall hold harmless the State, and shall provide the State and Agency with a defense against any and all claims including, but not limited to, the foregoing payments, withholdings, contributions, taxes, Social Security taxes, and employer income tax returns.

36. INDEMNIFICATION: The Vendor agrees to indemnify, defend, and hold harmless the State and the Agency, their officers, and employees from and against: (1) Any claims or losses for services rendered by any subcontractor, person, or firm performing or supplying services, materials, or supplies in connection with the performance of the Contract; (2) Any claims or losses resulting to any person or entity injured or damaged by the Vendor, its officers, employees, or subcontractors by the publication, translation, reproduction, delivery, performance, use, or disposition of any data used under the Contract in a manner not authorized by the Contract, or by Federal or State statutes or regulations; and (3) Any failure of the Vendor, its officers, employees, or subcontractors to observe State and Federal laws including, but not limited to, labor and wage and hour laws.

37. PURCHASING AFFIDAVIT: In accordance with West Virginia Code §§ 5A-3-10a and 5-22-1(i), the State is prohibited from awarding a contract to any bidder that owes a debt to the State or a political subdivision of the State, Vendors are required to sign, notarize, and submit the Purchasing Affidavit to the Purchasing Division affirming under oath that it is not in default on any monetary obligation owed to the state or a political subdivision of the state.

38. ADDITIONAL AGENCY AND LOCAL GOVERNMENT USE: This Contract may be utilized by other agencies, spending units, and political subdivisions of the State of West Virginia; county, municipal, and other local government bodies; and school districts ("Other Government Entities"), provided that both the Other Government Entity and the Vendor agree. Any extension of this Contract to the aforementioned Other Government Entities must be on the same prices, terms, and conditions as those offered and agreed to in this Contract, provided that such extension is in compliance with the applicable laws, rules, and ordinances of the Other Government Entity. A refusal to extend this Contract to the Other Government Entities shall not impact or influence the award of this Contract in any manner.

39. CONFLICT OF INTEREST: Vendor, its officers or members or employees, shall not presently have or acquire an interest, direct or indirect, which would conflict with or compromise the performance of its obligations hereunder. Vendor shall periodically inquire of its officers, members and employees to ensure that a conflict of interest does not arise. Any conflict of interest discovered shall be promptly presented in detail to the Agency.

40. REPORTS: Vendor shall provide the Agency and/or the Purchasing Division with the following reports identified by a checked box below:

Such reports as the Agency and/or the Purchasing Division may request. Requested reports may include, but are not limited to, quantities purchased, agencies utilizing the contract, total contract expenditures by agency, etc.

Quarterly reports detailing the total quantity of purchases in units and dollars, along with a listing of purchases by agency. Quarterly reports should be delivered to the Purchasing Division via email at purchasing.requisitions@wv.gov.

41. BACKGROUND CHECK: In accordance with W. Va. Code § 15-2D-3, the Director of the Division of Protective Services shall require any service provider whose employees are regularly employed on the grounds or in the buildings of the Capitol complex or who have access to sensitive or critical information to submit to a fingerprint-based state and federal background inquiry through the state repository. The service provider is responsible for any costs associated with the fingerprint-based state and federal background inquiry.

After the contract for such services has been approved, but before any such employees are permitted to be on the grounds or in the buildings of the Capitol complex or have access to sensitive or critical information, the service provider shall submit a list of all persons who will be physically present and working at the Capitol complex to the Director of the Division of Protective Services for purposes of verifying compliance with this provision. The State reserves the right to prohibit a service provider's employees from accessing sensitive or critical information or to be present at the Capitol complex based upon results addressed from a criminal background check.

Revised 01/09/2020

Service providers should contact the West Virginia Division of Protective Services by phone at (304) 558-9911 for more information.

42. PREFERENCE FOR USE OF DOMESTIC STEEL PRODUCTS: Except when authorized by the Director of the Purchasing Division pursuant to W. Va. Code § 5A-3-56, no contractor may use or supply steel products for a State Contract Project other than those steel products made in the United States. A contractor who uses steel products in violation of this section may be subject to civil penalties pursuant to W. Va. Code § 5A-3-56. As used in this section:

- a. "State Contract Project" means any erection or construction of, or any addition to, alteration of or other improvement to any building or structure, including, but not limited to, roads or highways, or the installation of any heating or cooling or ventilating plants or other equipment, or the supply of and materials for such projects, pursuant to a contract with the State of West Virginia for which bids were solicited on or after June 6, 2001.
- b. "Steel Products" means products rolled, formed, shaped, drawn, extruded, forged, cast, fabricated or otherwise similarly processed, or processed by a combination of two or more or such operations, from steel made by the open heath, basic oxygen, electric furnace, Bessemer or other steel making process. The Purchasing Division Director may, in writing, authorize the use of foreign steel products if:
- c. The cost for each contract item used does not exceed one tenth of one percent (.1%) of the total contract cost or two thousand five hundred dollars (\$2,500.00), whichever is greater. For the purposes of this section, the cost is the value of the steel product as delivered to the project; or
- d. The Director of the Purchasing Division determines that specified steel materials are not produced in the United States in sufficient quantity or otherwise are not reasonably available to meet contract requirements.

43. PREFERENCE FOR USE OF DOMESTIC ALUMINUM, GLASS, AND STEEL: In Accordance with W. Va. Code § 5-19-1 et seq., and W. Va. CSR § 148-10-1 et seq., for every contract or subcontract, subject to the limitations contained herein, for the construction, reconstruction, alteration, repair, improvement or maintenance of public works or for the purchase of any item of machinery or equipment to be used at sites of public works, only domestic aluminum, glass or steel products shall be supplied unless the spending officer determines, in writing, after the receipt of offers or bids, (1) that the cost of domestic aluminum, glass or steel products is unreasonable or inconsistent with the public interest of the State of West Virginia, (2) that domestic aluminum, glass or steel products are not produced in sufficient quantities to meet the contract requirements, or (3) the available domestic aluminum, glass, or steel do not meet the contract specifications. This provision only applies to public works contracts awarded in an amount more than fifty thousand dollars (\$50,000) or public works contracts that require more than ten thousand pounds of steel products.

The cost of domestic aluminum, glass, or steel products may be unreasonable if the cost is more than twenty percent (20%) of the bid or offered price for foreign made aluminum, glass, or steel products. If the domestic aluminum, glass or steel products to be supplied or produced in a

“substantial labor surplus area”, as defined by the United States Department of Labor, the cost of domestic aluminum, glass, or steel products may be unreasonable if the cost is more than thirty percent (30%) of the bid or offered price for foreign made aluminum, glass, or steel products. This preference shall be applied to an item of machinery or equipment, as indicated above, when the item is a single unit of equipment or machinery manufactured primarily of aluminum, glass or steel, is part of a public works contract and has the sole purpose or of being a permanent part of a single public works project. This provision does not apply to equipment or machinery purchased by a spending unit for use by that spending unit and not as part of a single public works project.

All bids and offers including domestic aluminum, glass or steel products that exceed bid or offer prices including foreign aluminum, glass or steel products after application of the preferences provided in this provision may be reduced to a price equal to or lower than the lowest bid or offer price for foreign aluminum, glass or steel products plus the applicable preference. If the reduced bid or offer prices are made in writing and supersede the prior bid or offer prices, all bids or offers, including the reduced bid or offer prices, will be reevaluated in accordance with this rule.

44. INTERESTED PARTY SUPPLEMENTAL DISCLOSURE: W. Va. Code § 6D-1-2 requires that for contracts with an actual or estimated value of at least \$1 million, the vendor must submit to the Agency a supplemental disclosure of interested parties reflecting any new or differing interested parties to the contract, which were not included in the original pre-award interested party disclosure, within 30 days following the completion or termination of the contract. A copy of that form is included with this solicitation or can be obtained from the WV Ethics Commission. This requirement does not apply to publicly traded companies listed on a national or international stock exchange. A more detailed definition of interested parties can be obtained from the form referenced above.

45. PROHIBITION AGAINST USED OR REFURBISHED: Unless expressly permitted in the solicitation published by the State, Vendor must provide new, unused commodities, and is prohibited from supplying used or refurbished commodities, in fulfilling its responsibilities under this Contract.

DESIGNATED CONTACT: Vendor appoints the individual identified in this Section as the Contract Administrator and the initial point of contact for matters relating to this Contract.

Patrick Holguin Government Account Representative

 (Name, Title)
 Patrick Holguin Government Account Representative

 (Printed Name and Title)
 87 wiseman run rd. Salem, WV 26426

 (Address)
 304-615-6340

 (Phone Number) / (Fax Number)
 pholguin@parcs.com

 (email address)

CERTIFICATION AND SIGNATURE: By signing below, or submitting documentation through wvOASIS, I certify that I have reviewed this Solicitation in its entirety; that I understand the requirements, terms and conditions, and other information contained herein; that this bid, offer or proposal constitutes an offer to the State that cannot be unilaterally withdrawn; that the product or service proposed meets the mandatory requirements contained in the Solicitation for that product or service, unless otherwise stated herein; that the Vendor accepts the terms and conditions contained in the Solicitation, unless otherwise stated herein; that I am submitting this bid, offer or proposal for review and consideration; that I am authorized by the vendor to execute and submit this bid, offer, or proposal, or any documents related thereto on vendor’s behalf; that I am authorized to bind the vendor in a contractual relationship; and that to the best of my knowledge, the vendor has properly registered with any State agency that may require registration.

THE TRACTOR GUYS LLC

 (Company)

 (Authorized Signature) (Representative Name, Title)
 Patrick Holguin Government Account Representative

 (Printed Name and Title of Authorized Representative)

1/31/20

 (Date)
 304-782-4111

 (Phone Number) (Fax Number)

ADDENDUM ACKNOWLEDGEMENT FORM
SOLICITATION NO.:

Instructions: Please acknowledge receipt of all addenda issued with this solicitation by completing this addendum acknowledgment form. Check the box next to each addendum received and sign below. Failure to acknowledge addenda may result in bid disqualification.

Acknowledgment: I hereby acknowledge receipt of the following addenda and have made the necessary revisions to my proposal, plans and/or specification, etc.

Addendum Numbers Received:

(Check the box next to each addendum received)

- | | |
|--|--|
| <input checked="" type="checkbox"/> Addendum No. 1 | <input type="checkbox"/> Addendum No. 6 |
| <input type="checkbox"/> Addendum No. 2 | <input type="checkbox"/> Addendum No. 7 |
| <input type="checkbox"/> Addendum No. 3 | <input type="checkbox"/> Addendum No. 8 |
| <input type="checkbox"/> Addendum No. 4 | <input type="checkbox"/> Addendum No. 9 |
| <input type="checkbox"/> Addendum No. 5 | <input type="checkbox"/> Addendum No. 10 |

I understand that failure to confirm the receipt of addenda may be cause for rejection of this bid. I further understand that any verbal representation made or assumed to be made during any oral discussion held between Vendor's representatives and any state personnel is not binding. Only the information issued in writing and added to the specifications by an official addendum is binding.

THE TRACTOR GUYS LLC

 Company

 Authorized Signature

1/31/20

 Date

NOTE: This addendum acknowledgment should be submitted with the bid to expedite document processing.

REQUEST FOR QUOTATION

Compact Track Excavator w/Attachments

SPECIFICATIONS

1. **PURPOSE AND SCOPE:** The West Virginia Purchasing Division is soliciting bids on behalf of the West Virginia Department of Environmental Protection (WVDEP), Rehabilitation Environmental Action Plan (REAP), to establish a contract for the one-time purchase of one (1) Hydraulic Compact Track Excavator and the associated listed attachments for the same.
2. **DEFINITIONS:** The terms listed below shall have the meanings assigned to them below. Additional definitions can be found in Section 2 of the General Terms and Conditions.
 - 2.1 **“Contract Item”** means Hydraulic Compact Excavator with Digging Bucket and Hydraulic Thumb, as more fully described by these specifications. All attachments are to be those able to be attached to and operated with the Excavator being bid and provided.
 - 2.2 **“Pricing Page”** means the pages, contained in wvOASIS or attached as Exhibit A, upon which Vendor should list its proposed price for the Contract Items.
 - 2.3 **“Solicitation”** means the official notice of an opportunity to supply the State with goods or services that is published by the Purchasing Division.
 - 2.4 **“WVDEP”** means The West Virginia Department of Environmental Protection.
 - 2.5 **“REAP”** means Rehabilitation Environmental Action Plan.
 - 2.6 **“GPM”** means gallons per minute.
 - 2.7 **“TOPS”** means tip over protection cover.
 - 2.8 **“ROPS”** means roll over protection structure.
 - 2.9 **“FLOPS”** means falling object protection structure.
 - 2.10 **“OEM”** means original equipment of manufacture.

REQUEST FOR QUOTATION

Compact Track Excavator w/Attachments

3. GENERAL REQUIREMENTS:

3.1 Mandatory Contract Item Requirements: Contract Item must meet or exceed the mandatory requirements listed below.

3.1.1 Hydraulic Compact Excavator with Digging Bucket and Hydraulic Thumb:

3.1.1.1 Operating weight shall be minimum of 7,200 pounds and not to exceed 8,300 pounds including thumb, blade, bucket and counterweight.

3.1.1.2 The unit specified herein and offered shall be the current model year available.

3.1.2 Engine:

3.1.2.1 Engine shall be a minimum of 23 horsepower; diesel engine, liquid cooled.

3.1.2.2 Engine shall include the following characteristics;

3.1.2.2.1 Fuel water separator filter factory installed

3.1.2.2.2 12-volt system

3.1.2.2.3 Electric fuel priming pump

3.1.2.2.4 Automatic idle system

3.1.3 Powertrain:

3.1.3.1 Shall have minimum of one (1) high and a minimum of one (1) low travel speed.

3.1.4 Hydraulic System:

3.1.4.1 Shall have hydraulic system that will accept different attachments and maintain safe oil temperature within manufacturers recommended operation range, during continuous operation under maximum working combinations.

3.1.4.2 Unit shall be equipped with a factory installed hydraulic thumb.

REQUEST FOR QUOTATION

Compact Track Excavator w/Attachments

- 3.1.4.3 Drive shall be hydrostatic design with independent track control.
- 3.1.4.4 Swing brake shall be wet-disc type.
- 3.1.4.5 Unit shall be joystick controlled with a minimum of one (1) additional actuator for auxiliary hydraulics.
- 3.1.4.6 Unit shall have control pattern-change valve.
- 3.1.4.7 Unit shall have auxiliary hydraulic valve section.
- 3.1.4.8 Unit shall have auxiliary hydraulic lines with quick couplers and a 3-way hydraulic valve to switch between attachments.
- 3.1.4.9 Unit shall have auxiliary work tool flow control adjustment capabilities.

3.1.5 Undercarriage:

- 3.1.5.1 Undercarriage frame shall be manufacturers standard for model bid and shall include:
 - 3.1.5.1.1 Rubber tracks minimum of 11.8 inches wide
 - 3.1.5.1.2 Track guides to prevent track misalignment
 - 3.1.5.1.3 Track adjustment shall be hydraulic design
 - 3.1.5.1.4 Belly pan guard
 - 3.1.5.1.5 Undercarriage with manufacturer's standard size hydraulic blade for model bid, with float

3.1.6 Cab:

- 3.1.6.1 Shall be all weather steel cab with ROPS/TOPS/FLOPS with all around visibility.
- 3.1.6.2 Cab shall have a suspension seat with padded arm rests.
- 3.1.6.3 Cab shall be equipped with manufacturers' heater and air conditioning system.
- 3.1.6.4 Cab shall be equipped with front windshield wiper and washer.

REQUEST FOR QUOTATION

Compact Track Excavator w/Attachments

3.1.6.5 Manufacturer's vandalism protection package shall be provided.

3.1.6.5.1 The vandalism protection package shall include locking cab doors, locking compartments for engine and hydraulic components, locking fuel and radiator access and electrical cutoff switch. All locks except master switch shall be keyed alike.

3.1.6.6 Shall have Interior cab light.

3.1.6.7 Cab shall have two work lights, one (1) on boom and one (1) on cab.

3.1.6.8 Cab shall have AM/FM radio with antenna.

3.1.6.9 Cab shall have motion alarm with cancel switch.

3.1.6.10 Cab shall be equipped with a horn.

3.1.6.11 Cab shall have one 12-volt accessory outlet.

3.1.6.12 Cab shall have complete engine monitoring system.

3.1.6.13 Cab shall have rear secondary exit kit.

3.1.6.14 Cab shall be wired for smart link capabilities.

3.1.6.15 Shall have Cab mirrors.

3.1.7 Maximum Reach and Digging Depth:

3.1.7.1 Unit bid shall have minimum digging depth of 9 foot and a minimum digging reach of 15 foot.

3.1.8 Counterweight:

3.1.8.1 Unit shall include the maximum available counterweight for unit bid.

REQUEST FOR QUOTATION

Compact Track Excavator w/Attachments

3.1.9 Bucket:

3.1.9.1 Unit shall include a minimum 16-inch maximum 20-inch digging bucket with replaceable teeth.

3.1.10 Compact Excavator Paint:

3.1.10.1 Unit shall be painted manufacturers standard color.

4. CONTRACT AWARD:

4.1 Contract Award: The Contract is intended to provide Agencies with a purchase price for the Contract Items. The Contract shall be awarded to the Vendor that provides the Contract Items meeting the required specifications for the lowest overall Total Bid Amount as shown on the Pricing Page.

4.2 Pricing Page: Vendor should complete the Pricing Page by entering their pricing information in wvOASIS. Vendor should complete the Pricing Page in full as failure to complete the Pricing Page in its entirety may result in Vendor's bid being disqualified.

Vendor should type or electronically enter the information into the Pricing Page to prevent errors in the evaluation.

4.2.1 Vendor's who wish to respond to a Centralized Request for Quotation (CRFQ) online may submit information through the State's wvOASIS Vendor Self Service (VSS).

Vendors should download the Exhibit "A": Pricing Page that is attached separately to the CRFQ and published to the VSS.

- **Vendor must identify Brand, Model and Year equipment being bid and include it with their submitted bid response.**

Any product brochures to support vendor's product should be submitted with vendor's bid response. These brochures and any supporting documentation may be required before award of contract.

5. PAYMENT:

REQUEST FOR QUOTATION

Compact Track Excavator w/Attachments

5.1 Payment: Vendor shall accept payment in accordance with the payment procedures of the State of West Virginia.

6. DELIVERY AND RETURN:

6.1 Shipment and Delivery: Vendor shall ship the Contract Items immediately after being awarded this Contract and receiving a purchase order or notice to proceed.

Vendor shall deliver the Contract Items within thirty (30) working days after receiving a purchase order or notice to proceed. Awarded Vendor must contact the Agency prior to delivery to schedule. Prior to delivery equipment must be completely serviced in accordance with Manufactures "make ready" preparation and in accordance with these specifications and the manufactures recommendations.

Contract Items must be delivered to Agency at:

601 57th Street, S.E., Charleston, WV 25304.

6.2 Late Delivery: The Agency placing the order under this Contract must be notified in writing if the shipment of the Contract Items will be delayed for any reason. Any delay in delivery that could cause harm to an Agency will be grounds for cancellation of the Contract, and/or obtaining the Contract Items from a third party.

Any Agency seeking to obtain the Contract Items from a third party under this provision must first obtain approval of the Purchasing Division.

6.3 Delivery Payment/Risk of Loss: Vendor shall deliver the Contract Items F.O.B. destination to the Agency's location.

6.4 Return of Unacceptable Items: If the Agency deems the Contract Items to be unacceptable, the Contract Items shall be returned to Vendor at Vendor's expense and with no restocking charge. Vendor shall either make arrangements for the return within five (5) days of being notified that items are unacceptable or permit the Agency to arrange for the return and reimburse Agency for delivery expenses. If the original packaging cannot be utilized for the return, Vendor will supply the Agency with appropriate return packaging upon request. All returns of unacceptable items shall be F.O.B. the Agency's location. The returned product shall either be replaced, or the Agency shall receive a full credit or refund for the purchase price, at the Agency's discretion.

6.5 Return Due to Agency Error: Items ordered in error by the Agency will be returned for credit within 30 days of receipt, F.O.B. Vendor's location. Vendor shall not charge a restocking fee if returned products are in a resalable condition. Items shall

Compact Track Excavator w/Attachments

be deemed to be in a resalable condition if they are unused and in the original packaging. Any restocking fee for items not in a resalable condition shall be the lower of the Vendor's customary restocking fee or 5% of the total invoiced value of the returned items.

7 VENDOR DEFAULT:

7.1 The following shall be considered a vendor default under this Contract.

- 7.1.1 Failure to provide Contract Items in accordance with the requirements contained herein.
- 7.1.2 Failure to comply with other specifications and requirements contained herein.
- 7.1.3 Failure to comply with any laws, rules, and ordinances applicable to the Contract Services provided under this Contract.
- 7.1.4 Failure to remedy deficient performance upon request.

7.2 The following remedies shall be available to Agency upon default.

- 7.2.1 Immediate cancellation of the Contract.
- 7.2.2 Immediate cancellation of one or more release orders issued under this Contract.
- 7.2.3 Any other remedies available in law or equity.

Exhibit A - Pricing Page
 West Virginia Department of Environmental Protection (WVDEP), REAP Section
 Compact Track Excavator w/Attachments

Item No.	Description	Year, Make, and Model	Quantity	Unit Price	Extended Price
3.1.1	Hydraulic Compact Excavator w/ matching Attachments	New Holland E37 CAB 2018	1	43,999.00	0.00
TOTAL BID AMOUNT:					0.00

Vendor must identify Make and Model at time of submitting Bid Response and should provide Product Brochures.

West Virginia Ethics Commission



Disclosure of Interested Parties to Contracts

Pursuant to *W. Va. Code* § 6D-1-2, a state agency may not enter into a contract, or a series of related contracts, that has/have an actual or estimated value of \$1 million or more until the business entity submits to the contracting state agency a Disclosure of Interested Parties to the applicable contract. In addition, the business entity awarded a contract is obligated to submit a supplemental Disclosure of Interested Parties reflecting any new or differing interested parties to the contract within 30 days following the completion or termination of the applicable contract.

For purposes of complying with these requirements, the following definitions apply:

"Business entity" means any entity recognized by law through which business is conducted, including a sole proprietorship, partnership or corporation, but does not include publicly traded companies listed on a national or international stock exchange.

"Interested party" or *"Interested parties"* means:

- (1) A business entity performing work or service pursuant to, or in furtherance of, the applicable contract, including specifically sub-contractors;
- (2) the person(s) who have an ownership interest equal to or greater than 25% in the business entity performing work or service pursuant to, or in furtherance of, the applicable contract. (This subdivision does not apply to a publicly traded company); and
- (3) the person or business entity, if any, that served as a compensated broker or intermediary to actively facilitate the applicable contract or negotiated the terms of the applicable contract with the state agency. (This subdivision does not apply to persons or business entities performing legal services related to the negotiation or drafting of the applicable contract.)

"State agency" means a board, commission, office, department or other agency in the executive, judicial or legislative branch of state government, including publicly funded institutions of higher education: Provided, that for purposes of *W. Va. Code* § 6D-1-2, the West Virginia Investment Management Board shall not be deemed a state agency nor subject to the requirements of that provision.

The contracting business entity must complete this form and submit it to the contracting state agency prior to contract award and to complete another form within 30 days of contract completion or termination.

This form was created by the State of West Virginia Ethics Commission, 210 Brooks Street, Suite 300, Charleston, WV 25301-1804. Telephone: (304)558-0664; fax: (304)558-2169; e-mail: ethics@wv.gov; website: www.ethics.wv.gov.

West Virginia Ethics Commission
Disclosure of Interested Parties to Contracts

(Required by W. Va. Code § 6D-1-2)

Name of Contracting Business Entity: The Tractor Guys LLC Address: 87 wiseman run rd. Salem, WV 26426

Name of Authorized Agent: Patrick Holguin Address: 87 wiseman run rd. Salem, WV 26426

Contract Number: _____ Contract Description: _____

Governmental agency awarding contract: _____

Check here if this is a Supplemental Disclosure

List the Names of Interested Parties to the contract which are known or reasonably anticipated by the contracting business entity for each category below (attach additional pages if necessary):

1. Subcontractors or other entities performing work or service under the Contract

Check here if none, otherwise list entity/individual names below.

2. Any person or entity who owns 25% or more of contracting entity (not applicable to publicly traded entities)

Check here if none, otherwise list entity/individual names below.

3. Any person or entity that facilitated, or negotiated the terms of, the applicable contract (excluding legal services related to the negotiation or drafting of the applicable contract)

Check here if none, otherwise list entity/individual names below.

Signature: _____

Date Signed: 1/31/20

Notary Verification

State of WEST VIRGINIA, County of HARRISON

I, Patrick Holguin, the authorized agent of the contracting business entity listed above, being duly sworn, acknowledge that the Disclosure herein is being made under oath and under the penalty of perjury.

Taken, sworn to and subscribed before me this 31 day of JANUARY, 2020

Janna E. Younk
Notary Public's Signature

To be completed by State Agency:

Date Received by State Agency: _____

Date submitted to Ethics Commission: _____

Governmental agency submitting Disclosure: _____

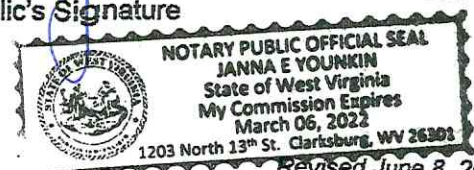

STATE OF WEST VIRGINIA
Purchasing Division

PURCHASING AFFIDAVIT

CONSTRUCTION CONTRACTS: Under W. Va. Code § 5-22-1(i), the contracting public entity shall not award a construction contract to any bidder that is known to be in default on any monetary obligation owed to the state or a political subdivision of the state, including, but not limited to, obligations related to payroll taxes, property taxes, sales and use taxes, fire service fees, or other fines or fees.

ALL CONTRACTS: Under W. Va. Code §5A-3-10a, no contract or renewal of any contract may be awarded by the state or any of its political subdivisions to any vendor or prospective vendor when the vendor or prospective vendor or a related party to the vendor or prospective vendor is a debtor and: (1) the debt owed is an amount greater than one thousand dollars in the aggregate; or (2) the debtor is in employer default.

EXCEPTION: The prohibition listed above does not apply where a vendor has contested any tax administered pursuant to chapter eleven of the W. Va. Code, workers' compensation premium, permit fee or environmental fee or assessment and the matter has not become final or where the vendor has entered into a payment plan or agreement and the vendor is not in default of any of the provisions of such plan or agreement.

DEFINITIONS:

"Debt" means any assessment, premium, penalty, fine, tax or other amount of money owed to the state or any of its political subdivisions because of a judgment, fine, permit violation, license assessment, defaulted workers' compensation premium, penalty or other assessment presently delinquent or due and required to be paid to the state or any of its political subdivisions, including any interest or additional penalties accrued thereon.

"Employer default" means having an outstanding balance or liability to the old fund or to the uninsured employers' fund or being in policy default, as defined in W. Va. Code § 23-2c-2, failure to maintain mandatory workers' compensation coverage, or failure to fully meet its obligations as a workers' compensation self-insured employer. An employer is not in employer default if it has entered into a repayment agreement with the Insurance Commissioner and remains in compliance with the obligations under the repayment agreement.

"Related party" means a party, whether an individual, corporation, partnership, association, limited liability company or any other form or business association or other entity whatsoever, related to any vendor by blood, marriage, ownership or contract through which the party has a relationship of ownership or other interest with the vendor so that the party will actually or by effect receive or control a portion of the benefit, profit or other consideration from performance of a vendor contract with the party receiving an amount that meets or exceeds five percent of the total contract amount.

AFFIRMATION: By signing this form, the vendor's authorized signer affirms and acknowledges under penalty of law for false swearing (W. Va. Code §61-5-3) that: (1) for construction contracts, the vendor is not in default on any monetary obligation owed to the state or a political subdivision of the state, and (2) for all other contracts, that neither vendor nor any related party owe a debt as defined above and that neither vendor nor any related party are in employer default as defined above, unless the debt or employer default is permitted under the exception above.

WITNESS THE FOLLOWING SIGNATURE:

Vendor's Name: THE TRACTOR GUYS LLC

Authorized Signature: [Signature] Date: 1/31/20

State of West Virginia

County of Harrison, to-wit:

Taken, subscribed, and sworn to before me this 31 day of JANUARY, 2020

My Commission expires 03/06/2022, 2022

AFFIX SEAL HERE

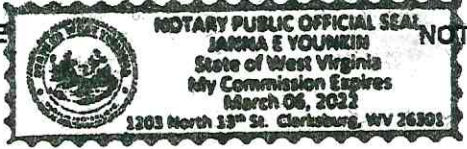

NOTARY PUBLIC

[Signature]
Purchasing Affidavit (Revised 01/19/2018)

State of West Virginia
VENDOR PREFERENCE CERTIFICATE

Certification and application is hereby made for Preference in accordance with **West Virginia Code**, §5A-3-37. (Does not apply to construction contracts). **West Virginia Code**, §5A-3-37, provides an opportunity for qualifying vendors to request (at the time of bid) preference for their residency status. Such preference is an evaluation method only and will be applied only to the cost bid in accordance with the **West Virginia Code**. This certificate for application is to be used to request such preference. The Purchasing Division will make the determination of the Vendor Preference, if applicable.

1. **Application is made for 2.5% vendor preference for the reason checked:**
 Bidder is an individual resident vendor and has resided continuously in West Virginia, or bidder is a partnership, association or corporation resident vendor and has maintained its headquarters or principal place of business continuously in West Virginia, for four (4) years immediately preceding the date of this certification; **or**,
 Bidder is a resident vendor partnership, association, or corporation with at least eighty percent of ownership interest of bidder held by another entity that meets the applicable four year residency requirement; **or**,
 Bidder is a nonresident vendor which has an affiliate or subsidiary which employs a minimum of one hundred state residents and which has maintained its headquarters or principal place of business within West Virginia continuously for the four (4) years immediately preceding the date of this certification; **or**,
2. **Application is made for 2.5% vendor preference for the reason checked:**
 Bidder is a resident vendor who certifies that, during the life of the contract, on average at least 75% of the employees working on the project being bid are residents of West Virginia who have resided in the state continuously for the two years immediately preceding submission of this bid; **or**,
3. **Application is made for 2.5% vendor preference for the reason checked:**
 Bidder is a nonresident vendor that employs a minimum of one hundred state residents, or a nonresident vendor which has an affiliate or subsidiary which maintains its headquarters or principal place of business within West Virginia and employs a minimum of one hundred state residents, and for purposes of producing or distributing the commodities or completing the project which is the subject of the bidder's bid and continuously over the entire term of the project, on average at least seventy-five percent of the bidder's employees or the bidder's affiliate's or subsidiary's employees are residents of West Virginia who have resided in the state continuously for the two immediately preceding years and the vendor's bid; **or**,
4. **Application is made for 5% vendor preference for the reason checked:**
 Bidder meets either the requirement of both subdivisions (1) and (2) or subdivision (1) and (3) as stated above; **or**,
5. **Application is made for 3.5% vendor preference who is a veteran for the reason checked:**
 Bidder is an individual resident vendor who is a veteran of the United States armed forces, the reserves or the National Guard and has resided in West Virginia continuously for the four years immediately preceding the date on which the bid is submitted; **or**,
6. **Application is made for 3.5% vendor preference who is a veteran for the reason checked:**
 Bidder is a resident vendor who is a veteran of the United States armed forces, the reserves or the National Guard, if, for purposes of producing or distributing the commodities or completing the project which is the subject of the vendor's bid and continuously over the entire term of the project, on average at least seventy-five percent of the vendor's employees are residents of West Virginia who have resided in the state continuously for the two immediately preceding years.
7. **Application is made for preference as a non-resident small, women- and minority-owned business, in accordance with West Virginia Code §5A-3-59 and West Virginia Code of State Rules.**
 Bidder has been or expects to be approved prior to contract award by the Purchasing Division as a certified small, women- and minority-owned business.
8. **Application is made for reciprocal preference.**
 Bidder is a West Virginia resident and is requesting reciprocal preference to the extent that it applies.

Bidder understands if the Secretary of Revenue determines that a Bidder receiving preference has failed to continue to meet the requirements for such preference, the Secretary may order the Director of Purchasing to: (a) rescind the contract or purchase order; or (b) assess a penalty against such Bidder in an amount not to exceed 5% of the bid amount and that such penalty will be paid to the contracting agency or deducted from any unpaid balance on the contract or purchase order.

By submission of this certificate, Bidder agrees to disclose any reasonably requested information to the Purchasing Division and authorizes the Department of Revenue to disclose to the Director of Purchasing appropriate information verifying that Bidder has paid the required business taxes, provided that such information does not contain the amounts of taxes paid nor any other information deemed by the Tax Commissioner to be confidential.

Bidder hereby certifies that this certificate is true and accurate in all respects; and that if a contract is issued to Bidder and if anything contained within this certificate changes during the term of the contract, Bidder will notify the Purchasing Division in writing immediately.

Bidder: THE TRACTOR GUYS LLC

Signed: 

Date: 1/31/20

Title: CHIEF OPERATING OFFICER

*Check any combination of preference consideration(s) indicated above, which you are entitled to receive.

COMPACT EXCAVATORS

E17C | E26C | E30C | E33C | E37C | E57C | E60C



The right tool for the job.

New Holland offers you a broad selection of compact excavators with seven models from 1.7 to 6.0 metric tons. With canopy and cab models, short radius (SR), zero tail swing (ZTS) and conventional versions to choose from, there is the right model ideally suited to landscaping, municipal, agriculture, horticulture, nurseries, vineyards, estate management and general contracting. Varied applications include track, irrigation and drainage system construction and maintenance, to fence installation and utility work.

With hydraulically powered attachments like soil augers, hammers and compactors, the boom and dipper offer power arm versatility with the strength of a large excavator. In addition, the available Object Handling Kit allows you to raise heavy, suspended loads using a lifting hook on the bucket linkage. You get all this versatility in one machine.

Small in size. Big on performance. Huge in versatility.

Compact dimensions enable New Holland C Series excavators to access difficult work areas. And, every model is built for high performance. Designed for day-long working, each model has class-leading excavation performance with the versatility to power a wide range of attachments



MODELS	DESIGN		GROSS POWER (HP)	OPERATING WEIGHT* lbs. (kg)		DESIGN	REAR OVERHANG ft. in. (mm)	BLADE WIDTH ft. in. (mm)	MAX DIGGING DEPTH ft. in. (mm)		MAX DUMP HEIGHT ft. in. (mm)	
	Cab	Canopy		Cab	Canopy				Standard Arm	Long Arm	Standard Arm	Long Arm
E17C	-	●	16.8	-	3910 (1775)	ZTS	0	3' 3" - 4' 3" (990 - 1300)	7' 3" (2200)	7' 9" (2350)	8' 5" (2570)	8' 10" (2670)
E26C	○	○	24.8	5850 (2655)	5520 (2505)	ZTS	0	5' 0" (1500)	7' 11" (2420)	8' 8" (2645)	9' 7" (2930)	9' 11" (3030)
E30C	○	○	24.8	6922 (3140)†	6592 (2990)†	SR	5" (127)	5' 1" (1550)	8' 2" (2500)	-	9' 7" (2930)	-
E33C	-	●	24.4	-	7682 (3485)†	SR	4" (102)	5' 1" (1550)	9' 11" (3035)	-	10' 9" (3275)	-
E37C	○	○	24.4	8300 (3765)	7990 (3625)	ZTS	0	5' 9" (1740)	10' 3" (3135)	11' 3" (3440)	11' 3" (3425)	11' 10" (3615)
E57C	●	-	66.9	12,050 (5465)	-	Conventional	2' 3" (690)	6' 4" (1920)	12' 6" (3820)	13' 4" (4060)	13' 3" (4050)	13' 9" (4180)
E60C	●	-	64.7	12,940 (5870)	-	SR	3" (80)	6' 7" (2010)	11' 9" (3570)	13' 1" (3990)	12' 11" (3930)	13' 5" (4100)

● Standard ○ Optional - Not available *Weight with full fuel tank, operator & bucket †Weight with standard additional counterweight

TABLE OF CONTENTS**PAGES**

Operator Platform and Cab.....	4-5
Controls	6-7
Hydraulics.....	8-9
Undercarriage	10-11
Engine	12-13
Service and Options.....	14-15
Specifications	16-17
Bucket and Coupler Guide	18-20
Lift Capacities.....	21-23



Designed around you.

Slim frame posts ensure excellent all-round visibility, with good views of the boom and dipper. When working in a confined area, in urban areas, or between valuable crops such as in a vineyard, nursery or an orchard, you can operate a New Holland compact excavator with absolute precision for minimal disruption.

Canopy or cab

New Holland E17C and E33C compact excavators are fitted with a canopy only, while the E26C, E30C and E37C are offered with a choice of canopy or full cab. The E57C and E60C are cab only. The E17 is TOPS (tip-over) / FOPS (falling-object) compliant, while all other models are TOPS/FOPS/ROPS (roll-over) compliant to ISO standards. Low noise and vibration levels ensure you can work for extended work periods in comfort with no compromise in operator safety.



- Adjustable suspension seat





- Powerful ventilation for cooling or heating
- Automatic climate control is standard on E57C and E60C



- Integrated cup holders are fitted to models E26C through E60C



- E26C through E60C models have a lockable storage compartment under the seat



- Adjustable wrist rests



- Front sun screen opens or can be raised clear



- Standard hands-free feature available on E57C and E60C
- Control your mobile phone and radio via Bluetooth

More power, more productivity, more value.

A comfortable operator is a safe and productive operator. All models have excellent ergonomics, with all primary controls positioned for easy access. The shape of the joysticks enables the operator to choose their preferred method of working the key excavator functions, allowing both gripped and palm down operating positions. The armrests adjust to deliver the required level of support and the foot pedals on the smaller models fold to increase floor space. Getting in and out the machine is simplified because the left-side console tilts out of the way, locking the hydraulics at the same time to prevent accidental operation.

- All controls are within easy reach
- Joysticks positioned for ease of use
- Safety lock prevents exit while hydraulic controls are live





- Standard digital side console on E17C, E26C, E30C, E33C and E37C
- Sealed against dust and moisture
- Integrated code anti-theft system
- Hour meter, engine speed and warning lights
- Fuel level and coolant temperature gauges



- Standard digital 5.7-inch (14.5cm) color LCD touchscreen display on E57C and E60C
- Displays engine speed and coolant temperature
- Hydraulic oil temperature
- Fuel level
- Maintenance information includes fault codes and diagnostics
- Input jack for optional rear view camera



- E17C to E37C joystick features full proportional control
- Optional integral buttons for auxiliary hydraulics



- E57C and E60C joystick features full proportional control
- Optional additional auxiliary controls on left joystick



- Fold-up travel pedals are fitted to all models (except E17C)

Smooth control, powerful performance.

The efficient conversion of engine power into hydraulic muscle lies behind the productivity of New Holland compact excavators. All models have three separate pumps to deliver optimized performance when traveling between sites or using the dozer blade, when working with the excavator and when driving hydraulic attachments. For demanding auxiliary attachments, a fourth pump option is available for the E57C and E60C.

The advance hydraulic system includes a swing parking brake and an arm flow summation system ensuring smooth and precise control. Other advance features include a hydraulically-lubricated swing reducer and a hydraulic damper in the travel pedal.

To further boost performance, the top two models have hydraulic flow summation. This advanced system delivers the enhanced proportional control typically restricted to high-capacity excavators exceeding 20-ton capacity.

Cushioned rams for:

- Smoother operation
- Greater operator comfort
- Reduced machine wear

Hydraulic accumulator delivers:

- Cushioned shock loads
- Oil loss mitigation
- Vibration damping
- Emergency hydraulic function

Separate hydraulic pumps deliver:

- Cooler running
- Greater efficiency
- Faster hydraulic response
- Dedicated flow to meet demand
- Fourth pump option E57C and E60



Standard and long arm choice

Specify your C Series compact excavator with the arm length to best suit your requirements.

MODEL	STANDARD ARM LENGTH ft. in. (mm)	LONG ARM LENGTH ft. in. (mm)
E17C	3' 2" (965)	3' 8" (1117)
E26C	3' 8" (1117)	4' 5" (1346)
E30C	3' 8" (1117)	-
E33C	4' 3" (1295)	-
E37C	4' 3" (1295)	5' 3" (1295)
E57C	5' 3" (1295)	6' 3" (1905)
E60C	4' 10" (1295)	6' 3" (1905)

- Not available

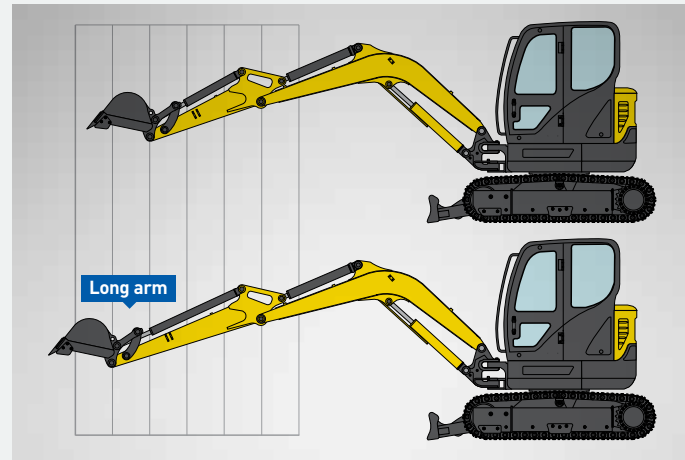

Ample boom swing angles

- Efficient parallel digging: good for working along side obstacles
- Less time: no need to reposition the machine, get the job done faster
- Better visibility: larger left swing angle to the side of the door

MODEL	LEFT SWING (degrees)	RIGHT SWING (degrees)
E17C	70	54
E26C	75	50
E30C	75	50
E33C	75	50
E37C	75	50
E57C	80	50
E60C	70	50

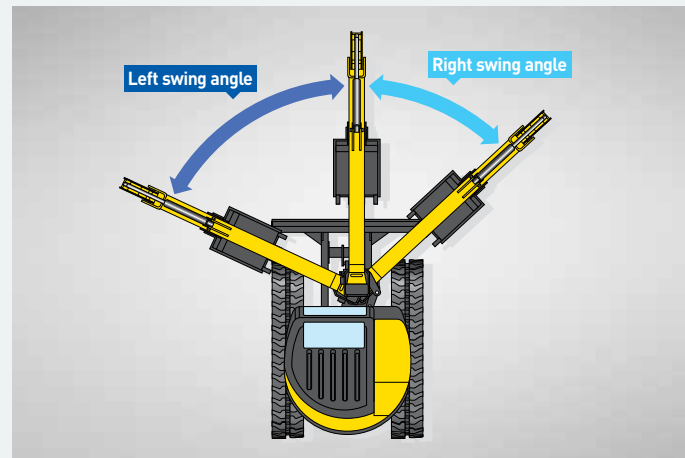

Auxiliary hydraulic power and versatility

- Power for couplers and thumbs
- Reversible flow for augers
- High-capacity constant flow for compactors
- Power for hydraulic hammers

Intelligent features

- Hydraulic flow summation system
- Boom hold
- Swing parking brake
- Excellent hydraulic hose protection
- Cylinder protection covers on boom, dipper and dozer



Boom pivot pins secured by plate and bolt

- Reduced lateral movement
- Long service life
- Reliable performance in tough conditions
- Lower whole life operating costs



Excellent stability, maximum traction.

Built for versatility, New Holland mini-excavators have powerful traction matched to a low center of gravity for stability across difficult terrain. The dozer blade, which is lowered for stability when excavating, features excellent geometry for leveling and grading. Dependent upon model, there are four choices of track design, with the E17C featuring hydraulic variable track width.

All models feature Auto-Shift. Based on load condition, the two-speed drive automatically shifts into low range to maintain forward speed with no input from the operator and returns to high when load reduces.



Auto Shift Down

- Always travel at the machine's highest speed. Auto-Shift is available on all models

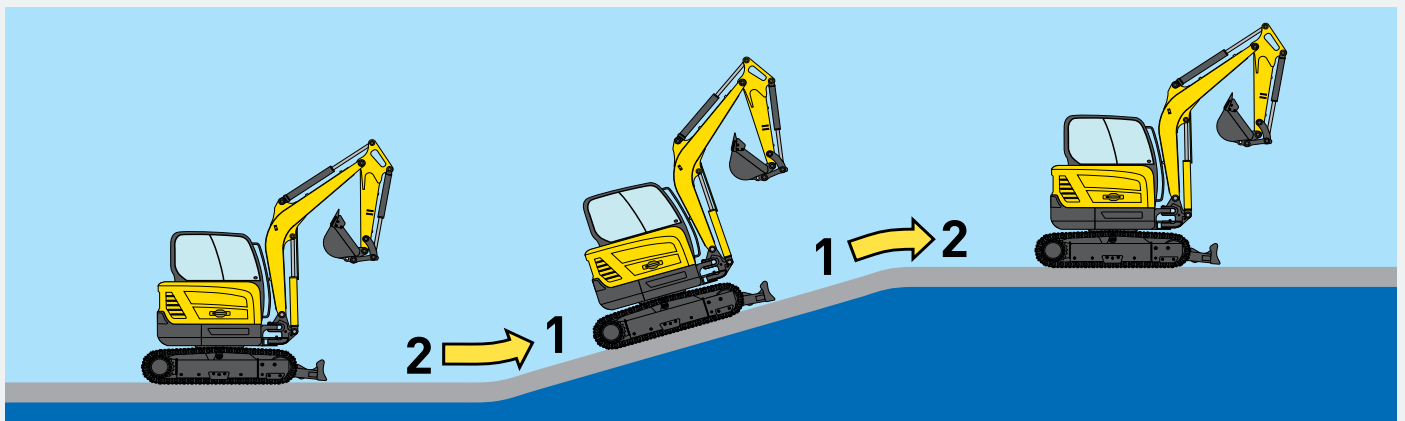

- E17C travel motor hoses run inside the track frame for protection
- Excellent ground clearance, up to 6.7 inches (170 mm) on the E17C
- Double-flange rollers are standard to minimize the risk of de-tracking



- E17C track width adjusts from 39 to 51 inches (980 to 1300 mm)
- This function is hydraulically controlled from the operator seat



- Dozer blade extenders are standard on variable track width on the E17C model
- Simple pin lock system



TRACK SELECTION		E17C	E27C	E30C	E33C	E37C	E57C	E60C
1 - Rubber tracks	in. (mm)	9.1 (230)	9.8 (250)	11.8 (300)	11.8 (300)	11.8 (300)	15.7 (400)	15.7 (400)
2 - Rubber link tracks	in. (mm)	-	-	-	-	-	15.7 (400)	15.7 (400)
3 - Steel tracks	in. (mm)	-	-	-	11.8 (300)	11.8 (300)	15/17.7 (380/450)	15/17.7 (380/450)
4 - Steel tracks with rubber pads	in. (mm)	-	-	-	-	-	15.7 (400)	15.7 (400)

- Not available

Efficient, Powerful, Dependable.

New Holland mini-excavators are compliant with Tier 4 Final emission regulations and employ different after treatment technologies to achieve this. Each model has a power unit selected to match the excavators size and capacity. This ensures optimized performance and fuel economy. To further enhance economy, the E33C, E37C, E57C and E60C are fitted with Auto-idle.

MODEL	Gross Power (hp)	Emission Level	Tier 4 Technology
E17C	16.8	Tier 4B	Mechanical - No ATS
E26C	24.8	Tier 4B	Mechanical - No ATS
E30C	24.8	Tier 4B	Mechanical - No ATS
E33C	24.4	Tier 4B	Mechanical + CEGR
E37C	24.4	Tier 4B	Mechanical + CEGR
E57C	66.9	Tier 4B	Electronic + CEGR + DPF
E60C	64.7	Tier 4B	Electronic + CEGR + DPF

Auto-idle (E33C, E37C, E57C and E60C)

When the hydraulics or traction motors are not demanding oil, the engine speed is reduced to idle with no input required from the operator. This feature can be turned on or off via a simple switch on the main console.

- Reduced fuel consumption
- Reduced engine noise
- Reduced wear



Attachments for dedicated efficiency.

A compact excavator is far more versatile than you think. With the right attachment, these machines can be used for a diverse range of jobs from fence installation to concrete breaking. With New Holland models you have the added advantage of high constant hydraulic flow. Powering demanding attachments is a key New Holland advantage. The range of attachments developed for compact excavators continues to grow, further increasing your job site versatility.

Hydraulic Quick Coupler

- Hands-free coupling and release of buckets
- Safely swap between large, heavy attachments
- Mechanical quick lock attachment brackets are also available



Attachments available

- Standard or Ditching Bucket
- Thumbs
- Soil Auger
- Hydraulic Hammer
- Hydraulic Compactor
- Mechanical & Hydraulic Coupler



Compactor

Ideal for slope compaction, road maintenance and construction sites.



Soil auger

Soil augers, of varying sizes, for post holes or planting trees and shrubs.



Hammer

Hammer circuit for high impact attachments.

Ease of care protects your investment.

Preparing a New Holland C Series mini-excavator for work takes less time. Routine maintenance tasks are simplified, with all key check and service points grouped together. For secure transport on a trailer, easy access lashing points are fitted.

Long service intervals

- Main pivots — lubricate every 250 hours
- Polymer shims — long life, maintenance free
- Extended life hydraulic filters — 1,000 hour change interval
- Long-life hydraulic oil — 5,000 hour change interval



Sight glass allows hydraulic oil level to be checked quickly and with no need to lift the engine hood



Centralized grease points



Forward tilting cab on E60C eases maintenance access





A lifting hook is standard on all models (except E17C)

Customize your machine

Install these extras to upgrade your machine to match the needs of your operation.

- Air conditioning (models E37C, E57C and E60C)
- Object handling kit
- Counterweights
- Second 2-way auxiliary



FLEETFORCE

FleetForce™ Telematics: Real-time equipment monitoring, anytime, anywhere

Take control of your fleet—wherever you are—with New Holland FleetForce™ telematics. With just a few simple clicks of a button, FleetForce uses remote-monitoring applications to deliver detailed information regarding your machines, allowing you to keep track of multiple machines at multiple job sites — especially helpful when you operate a large fleet or rental operation. Unlike other systems, FleetForce tracks location even when machines are turned off. Every New Holland compact excavator is pre-wired telematics ready. Ask your New Holland dealer about available FleetForce subscriptions so you can take advantage of these benefits:

- Know the location and status of every machine in your fleet
- Track machine utilization and identify inefficiencies and excessive idling to save money and fuel
- Increase security with geo-fencing, curfew, motion sensing
- Better maintenance scheduling with automatic alerts and diagnostics
- Faster, more accurate job costing with machine hours and fuel reports

Models		E17C	E26C	E30C	E33C	E37C	E57C	E60C
Engines		Kubota	Kubota	Kubota	Yanmar	Yanmar	Yanmar	Yanmar
Type		D902	D1305	D1305	3TNV88F	3TNV88F	4TNV98C	4TNV98C
N° of cylinders		3	3	3	3	3	4	4
Displacement	in³ (cm³)	54.8 (898)	77 (1261)	77 (1261)	100.2 (1642)	100.2 (1642)	203 (3319)	203 (3319)
Emissions Certification Tier		4B	4B	4B	4B	4B	4B	4B
Rated gross horse power	hp (kW)	16.8 (12.5)	24.8 (18.5)	24.8 (18.5)	24.4 (18.2)	24.4 (18.2)	65.1 (48.5)	64.7 (48.3)
@ rated speed	rpm	2300	2300	2300	2200	2200	2400	2200
Max torque	lb. ft. (Nm)	39.49 (54)	60 (81)	60 (81)	69.4 (94)	69.4 (94)	174 (235)	174 (235)
@ rated speed	rpm	1900	1600	1600	1200	1200	1550	1560
Diesel tank capacity	gal. (L)	5.3 (20)	7.9 (30)	7.9 (30)	7.9 (30)	10.5 (40)	31.7 (120)	21.7 (82)
Hydraulic system								
Variable displacement axial piston pumps		●	●	●	●	●	●	●
Maximum flow	gpm (Lpm)	2 x 5 (2 x 18.8)	2 x 7.3 (2 x 27.6)	2 x 7.3 (2 x 27.6)	2 x 9.9 (2 x 37.4)	2 x 9.9 (2 x 37.4)	2 x 15.3 (2 x 57.8)	2 x 14.5 (2 x 55)
Maximum pressure	psi (bar)	3270 (230)	3430 (240)	3430 (240)	3560 (250)	3560 (250)	3410 (240)	3410 (240)
Gear pump delivery flow	gpm (Lpm)	1.8 (6.8)	5.2 (19.6)	5.2 (19.6)	6.1 (23.1)	6.1 (23.1)	12.7 (47.9)	9.7 (36.6)
Gear pump delivery pressure	psi (bar)	2420 (170)	2538 (175)	2538 (175)	2916 (205)	2916 (205)	3130 (220)	3130 (220)
Dedicated Hammer Circuit 1-way flow	gpm (Lpm)	–	–	–	–	–	17.2 (65)	17.2 (65)
Dedicated Hammer Circuit 1-way pressure	psi (bar)	–	–	–	–	–	3191 (220)	3191 (220)
1st Auxiliary 1-way/2-way Circuit flow ¹	gpm (Lpm)	7.2 (27.4)	12.5 (47.2)	12.5 (47.2)	16 (60.5)	16 (60.5)	17.2 (65)	17.2 (65)
1st Auxiliary 1-way/2-way Circuit pressure ¹	psi (bar)	2420 (170)	2538 (175)	2538 (175)	2973 (205)	2973 (205)	3191 (220)	3191 (220)
2nd Auxiliary 2-way Circuit flow	gpm (Lpm)	–	12.5 (47.2)	12.5 (47.2)	16 (60.5)	16 (60.5)	8.7 (33)	8.7 (33)
2nd Auxiliary 2-way Circuit pressure	psi (bar)	–	2538 (175)	2538 (175)	2973 (205)	2973 (205)	2321 (160)	2321 (160)
Transmission								
Type		two speed	two speed	two speed	two speed	two speed	two speed	two speed
Travel Speed - Low (1st)	mph (kph)	1.4 (2.2)	1.5 (2.4)	1.5 (2.4)	1.5 (2.4)	1.6 (2.5)	1.3 (2.1)	1.4 (2.2)
Travel Speed - High (2nd)	mph (kph)	2.6 (4.2)	2.7 (4.3)	2.7 (4.3)	2.6 (4.2)	2.6 (4.2)	2.5 (4.1)	2.5 (4.0)
Slewing								
Slewing speed	rpm	9.5	9.1	9.1	9.0	9.5	9.1	8.8
Boom slewing angle - left/right	degrees	70 / 54	75 / 50	75 / 50	75 / 50	75 / 50	80 / 50	70 / 50
Transport feature*								
A - Max length	ft. in. (mm)	11' 5" (3480)	13' 3" (4030)	13' 9" (4180)	15' 3" (4640)	15' 4" (4665)	19' 4" (5900)	18' 3" (5600)
B - Max height	ft. in. (mm)	7' 7" (2320)	8' 2" (2500)	8' 2" (2500)	8' 2" (2500)	8' 2" (2500)	8' 4" (2550)	8' 4" (2550)
C - Max width	ft. in. (mm)	3' 3" (990)	4' 11" (1500)	5' 1" (1550)	5' 1" (1550)	5' 9" (1740)	6' 4" (1920)	6' 4" (1940)
Max width tracks extended	ft. in. (mm)	4' 3" (1300)	–	–	–	–	–	–
Operating weight*								
Cab	lb. (kg)	–	5850 (2655)	6636 (3010)	–	8300 (3765)	12,050 (5465)	12,940 (5870)
Cab with additional counterweight	lb. (kg)	–	6136 (2785)	6922 (3140)	–	8630 (3915)	12,270 (5565)	13,160 (5970)
Canopy	lb. (kg)	3910 (1775)	5520 (2505)	6306 (2860)	7396 (3355)	7990 (3625)	–	–
Canopy with additional counterweight	lb. (kg)	4,090 (1857)	5806 (2635)	6592 (2990)	7682 (3485)	8320 (3775)	–	–

● Standard – Not available * Weight is with rubber tracks / 165 lb operator / full fuel tank and fluids / bucket / no coupler

¹ Selection valve for 1-way or 2-way flow

Models		E17C	E26C	E30C	E33C	E37C	E57C	E60C
Dimensions								
R - Tail swing radius	ft. in. (mm)	2' 1" (645)	2' 6" (750)	2' 10" (863)	2' 10" (863)	2' 10" (870)	5' 5" (1650)	3' 7" (1080)
H - Track shoe width	ft. in. (mm)	9' 0" (230)	9.8" (250)	11.8" (300)	12" (300)	12" (300)	1' 3" (380)	1' 3" (380)
I - Ground clearance of rear end	ft. in. (mm)	1' 5" (440)	1' 8" (510)	1' 8" (510)	1' 9" (540)	1' 9" (540)	2' 3" (690)	2' 2" (660)
J - Overall Length of Crawler	ft. in. (mm)	5' 3" (1590)	6' 3" (1910)	6' 6" (1970)	7' (2130)	7' (2130)	8' 4" (2530)	8' 4" (2530)
K - Center distance of tumbler	ft. in. (mm)	4' 0" (1230)	4' 11" (1490)	5' 1" (1550)	5' 7" (1700)	5' 7" (1700)	6' 6" (1990)	6' 3" (1990)
L - Blade max lifting	ft. in. (mm)	11.2" (285)	1' 1" (330)	1' 7" (482)	1' 4" (400)	1' 3" (380)	1' 3" (380)	8" (200)
M - Blade max lowering	ft. in. (mm)	8.9" (225)	1' 3" (380)	1' 6" (450)	1' 5" (435)	1' 3" (380)	1' 11" (590)	2' 4" (700)
N - Blade width	ft. in. (mm)	3' 3" / 4' 3" (990 / 1300)	5' 0" (1500)	5' 1" (1550)	5' 1" (1550)	5' 9" (1740)	6' 4" (1920)	6' 7" (2010)
O - Blade height	ft. in. (mm)	9.8" (250)	12" (300)	1' 1" (330)	1' 1" (330)	1' 3" (380)	1' 2" (350)	1' 2" (350)
O' - Ground clearance of undercarriage	ft. in. (mm)	6.7" (170)	11" (290)	11" (290)	11" (290)	11" (290)	1' 3" (380)	1' 3" (380)

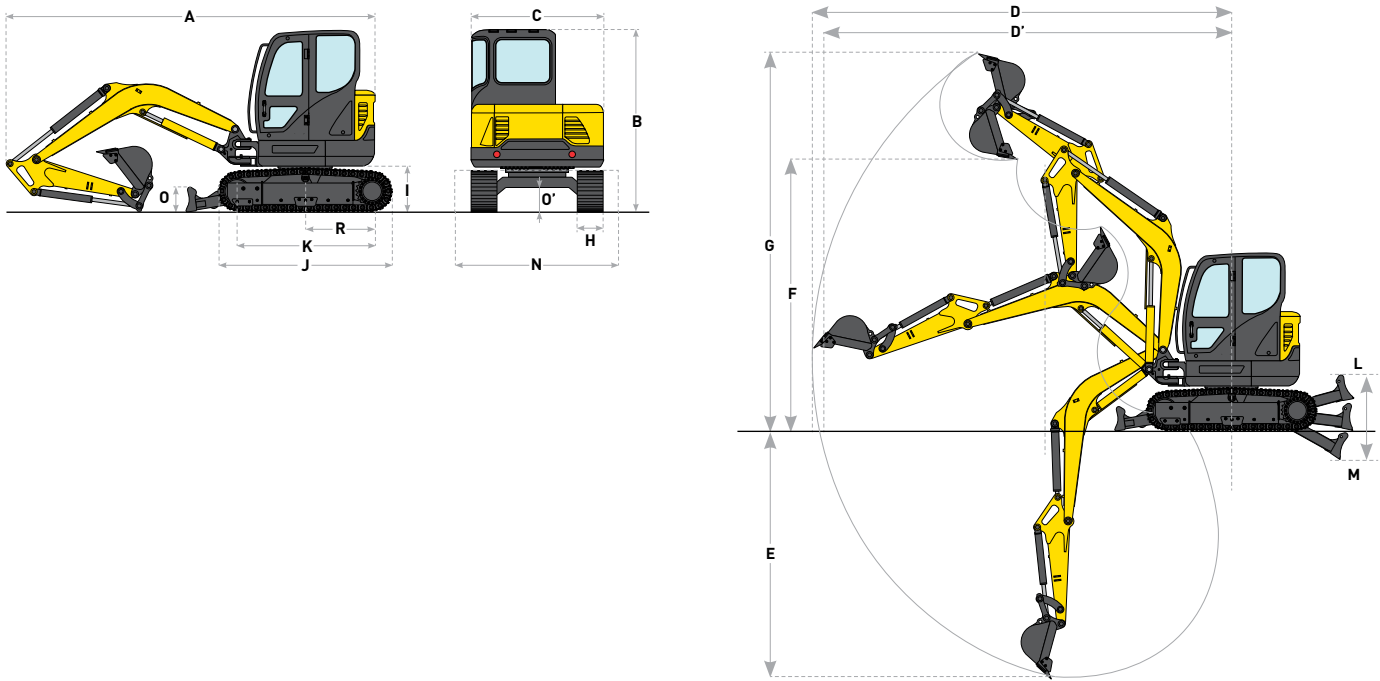

Models		E17C		E26C		E30C		E33C		E37C		E57C		E60C	
Digging performances															
Arm		Std.	Long	Std.	Long	Std.	Long	Std.	Long	Std.	Long	Std.	Long	Std.	Long
Dipperstick	ft. in. (mm)	3' 2" (960)	3' 8" (1120)	3' 8" (1120)	4' 5" (1350)	3' 8" (1120)	-	4' 3" (1300)	-	4' 3" (1300)	5' 3" (1600)	5' 3" (1600)	6' 3" (1900)	4' 10" (1480)	6' 3" (1900)
Dipperstick Breakout force (ISO)	lbf (kN)	1920 (8.5)	1710 (7.6)	3280 (14.6)	2880 (12.8)	3080 (13.7)	-	4390 (19.5)	-	4390 (19.5)	3800 (16.9)	7190 (31.9)	6460 (28.7)	5950 (26.5)	5035 (22.4)
Bucket Breakout force (ISO)	lbf (kN)	3490 (15.5)	3490 (15.5)	4740 (21.1)	4740 (21.1)	4520 (20.1)	-	6900 (30.7)	-	6900 (30.7)	6900 (30.7)	9550 (42.4)	9550 (42.4)	9190 (40.9)	9190 (40.9)
D - Max reach	ft. in. (mm)	12' 10" (3900)	13' 3" (4030)	14' 8" (4480)	15' 4" (4680)	15' 3" (4650)	-	17' (5180)	-	17' 5" (5315)	18' 5" (5605)	20' 2" (6150)	21' (6400)	20' 2" (6150)	21' 3" (6480)
D' - Max reach at ground level	ft. in. (mm)	12' 6" (3800)	12' 11" (3940)	14' 3" (4340)	14' 11" (4540)	14' 10" (4515)	-	16' 7" (5060)	-	17' 1" (5200)	18' (5495)	19' 9" (6010)	20' 7" (6270)	19' 9" (6010)	20' 10" (6350)
E - Max digging depth	ft. in. (mm)	7' 3" (2200)	7' 9" (2350)	7' 11" (2420)	8' 8" (2645)	8' 2" (2500)	-	9' 11" (3035)	-	10' 3" (3135)	11' 3" (3440)	12' 6" (3820)	13' 4" (4060)	11' 9" (3570)	13' 1" (3990)
F - Max dump height	ft. in. (mm)	8' 5" (2570)	8' 10" (2670)	9' 7" (2930)	9' 11" (3030)	9' 7" (2930)	-	10' 9" (3275)	-	11' 3" (3425)	11' 10" (3615)	13' 3" (4050)	13' 9" (4180)	12' 11" (3930)	13' 5" (4100)
G - Max digging height	ft. in. (mm)	11' 9" (3580)	12' 1" (3680)	13' 7" (4150)	13' 11" (4235)	14' (4270)	-	15' 3" (4650)	-	15' 9" (4810)	16' 7" (5010)	19' (5780)	19' 5" (5920)	18' 8" (5680)	19' 2" (5850)

Pin-On Bucket Offering				
Width in. (mm)	Cut in. (mm)	Rated ft.³ (liter)	No. of Teeth	Weight lbs. (kg)
E17C (1-position)				
10 (254)	11 (279)	.87 (25)	3	79 (36)
12 (305)	13 (330)	1.0 (28)	3	86 (39)
16 (406)	17 (432)	1.3 (37)	3	97 (44)
18 (457)	19 (483)	1.5 (42)	4	106 (48)
E26C & E30C (1-position)				
12 (305)	13 (330)	1.3 (37)	3	121 (55)
18 (457)	19 (483)	2.0 (57)	4	154 (70)
24 (610)	25 (635)	2.7 (76)	5	185 (84)
E30C high-capacity (1-position)				
12 (305)	13 (330)	2.1 (59)	3	161 (73)
18 (457)	19 (483)	3.2 (91)	4	189 (86)
24 (610)	25 (635)	4.3 (119)	5	249 (113)
E33C & E37C (1-position)				
12 (305)	13 (330)	2.2 (62)	3	161 (73)
18 (457)	19 (483)	3.2 (91)	4	205 (93)
24 (610)	25 (635)	4.2 (119)	5	247 (112)
36 (914)	37 (940)	6.4 (181)	6	331 (150)
E57C & E60C (1-position)				
12 (305)	13 (330)	3.0 (85)	3	190 (86)
18 (457)	19 (483)	4.5 (127)	4	240 (109)
24 (610)	25 (635)	6.3 (178)	5	291 (132)
36 (914)	37 (940)	9.8 (278)	6	388 (176)

NOTE: See page 20 for Coupler descriptions



18" Pin-On Bucket



36" Pin-On Bucket

Klac Bucket Offering

Width in. (mm)	Cut in. (mm)	Rated ft. ³ (liter)	No. of Teeth	Weight lbs. (kg)
E17C				
10 (254)	11 (279)	.87 (25)	3	88 (40)
12 (305)	13 (330)	1.0 (28)	3	95 (43)
16 (406)	17 (432)	1.5 (42)	3	106 (48)
18 (457)	19 (483)	1.8 (51)	4	117 (53)
E26C & E30C				
12 (305)	13 (330)	1.4 (39)	3	143 (65)
18 (457)	19 (483)	2.1 (58)	4	176 (80)
24 (610)	25 (635)	2.8 (78)	5	209 (95)
E33C & E37C				
12 (305)	13 (330)	2.2 (62)	3	179 (81)
18 (457)	19 (483)	3.2 (91)	4	223 (101)
24 (610)	25 (635)	4.2 (119)	5	267 (121)
36 (914)	37 (940)	6.4 (181)	6	348 (158)
E57C & E60C				
12 (305)	13 (330)	3.0 (85)	3	220 (100)
18 (457)	19 (483)	3.6 (102)	4	256 (116)
24 (610)	25 (635)	5.0 (142)	5	309 (140)
36 (914)	37 (940)	7.8 (221)	6	408 (185)

NOTE: See page 20 for Coupler descriptions



Klac Bucket

Coupler Specs		
Style	Weight lbs. (kg)	Application Notes
E17C		
Mechanical	65 (29)	For use where bucket (accessory) changes are frequent.
Klac	30 (14)	The low profile of the Klac style coupler is designed to mitigate the loss of breakout force.
E26C & E30C		
Mechanical	95 (43)	For use where bucket (accessory) changes are frequent.
Hydraulic	95 (43)	For use where bucket (accessory) changes are frequent and operator convenience is key factor.
Klac	60 (27)	The low profile of the Klac style coupler is designed to mitigate the loss of breakout force.
E33C & E37C		
Mechanical	97 (44)	For use where bucket (accessory) changes are frequent.
Hydraulic	115 (52)	For use where bucket (accessory) changes are frequent and operator convenience is key factor.
Klac	115 (52)	The low profile of the Klac style coupler is designed to mitigate the loss of breakout force.
E57C & E60C		
Mechanical	165 (75)	For use where bucket (accessory) changes are frequent.
Hydraulic	154 (70)	For use where bucket (accessory) changes are frequent and operator convenience is key factor.
Klac	110 (50)	The low profile of the Klac style coupler is designed to mitigate the loss of breakout force.



Mechanical Coupler



Klack Coupler & Bucket

Specialty Bucket Offering					
Width in. (mm)	Cut in. (mm)	Rated ft. ³ (liter)	No. of Teeth	Weight lbs. (kg)	Bolt-On Edge (Not Included)
E33C & E37C Ditch Cleaning Buckets - Pin-On					
36 (914)	37 (940)	6.6 (187)	-	233 (106)	Available
E33C & E37C Ditch Cleaning Buckets - Klac					
36 (914)	37 (940)	6.6 (187)	-	315 (143)	Available
E57C & E60C Ditch Cleaning Buckets - Pin-On					
36 (914)	37 (940)	6.6 (187)	-	238 (108)	Available
E57C & E60C Ditch Cleaning Buckets - Klac					
36 (914)	37 (940)	6.6 (187)	-	315 (143)	Available
E57C & E60C Cemetery Buckets - Pin-On					
36 (914)	37 (940)	3.5 (99)	6	269 (122)	-
E57C & E60C Cemetery Buckets - Klac					
36 (914)	37 (940)	3.5 (99)	6	310 (141)	-

- Not available

E17C Standard Arm

5 ft. 11 in. (1.8 m) Boom, 3 ft. 2 in. (0.96 m) Arm, Dozer Blade Down

Canopy unit equipped with 0.04 m³ (SAE heaped) bucket, 9 in. (230 mm) rubber track (extended) and 414 lb. (188 kg) counterweight.

Load/Lift point height		Load Radius										At Maximum Reach				
		3 ft. (1.0 m)		5 ft. (1.5 m)		7 ft. (2.0 m)		8 ft. (2.5 m)		10 ft. (3.0 m)		Reach ⌀	Capacity			
		end	side	end	side	end	side	end	side	end	side		end	side		
+7 ft. (2.0 m)	lb. (kg)									710* (320)*	710* (320)*	710* (320)*	510 (230)	10 ft. 1 in. (3.07 m)	560* (260)*	490 (220)
Groundline	lb. (kg)			1520* (690)*	1410 (640)	1740* (790)*	860 (390)	1220* (550)*	610 (280)	930* (420)*	460 (210)		10 ft. 8 in. (3.26 m)	820* (370)*	400 (180)	
-3 ft. (-1.0 m)	lb. (kg)	2280* (1030)*	2280* (1030)*	2180* (990)*	1440 (650)	1480* (670)*	870 (390)	1050* (480)*	610 (280)				8 ft. 11 in. (2.71 m)	900* (410)*	540 (240)	

E17C Long Arm

5 ft. 11 in. (1.8 m) Boom, 3 ft. 8 in. (1.12 m) Arm, Dozer Blade Down

Canopy unit equipped with 0.04 m³ (SAE heaped) bucket, 9 in. (230 mm) rubber track (extended) and 591 lb. (268 kg) counterweight.

Load/Lift point height		Load Radius										At Maximum Reach				
		3 ft. (1.0 m)		5 ft. (1.5 m)		7 ft. (2.0 m)		8 ft. (2.5 m)		10 ft. (3.0 m)		12 ft. (3.5 m)		Reach ⌀	Capacity	
		end	side	end	side	end	side	end	side	end	side	end	side		end	side
+10 ft. (3.0 m)	lb. (kg)													8 ft. 0 in. (2.43 m)	550* (250)*	550* (250)*
Groundline	lb. (kg)	880* (400)*	880* (400)*	1500* (680)*	1500* (680)*	1700* (770)*	970 (440)	1190* (540)*	690 (310)	910* (410)*	520 (240)			11 ft. 3 in. (3.42 m)	640* (290)*	420 (190)
-3 ft. (-1.0 m)	lb. (kg)	1980* (900)*	1980* (900)*	2350* (1070)*	1590 (720)	1540* (700)*	970 (440)	1100* (500)*	680 (310)				9 ft. 7 in. (2.91 m)	840* (380)*	540 (250)	

E26C Standard Arm

6 ft. 5 in. (1.9 m) Boom, 3 ft. 8 in. (1.12 m) Arm, Dozer Blade Down

Canopy unit equipped with 0.07 m³ (SAE heaped) bucket, 10 in. (250 mm) rubber track and 258 lb. (117 kg) counterweight.

Load/Lift point height		Load Radius										At Maximum Reach				
		3 ft. (1.0 m)		5 ft. (1.5 m)		7 ft. (2.0 m)		8 ft. (2.5 m)		10 ft. (3.0 m)		12 ft. (3.5 m)		Reach ⌀	Capacity	
		end	side	end	side	end	side	end	side	end	side	end	side		end	side
+10 ft. (3.0 m)	lb. (kg)									1290* (580)*	800 (360)			10 ft. 4 in. (3.16 m)	1350* (610)*	720 (330)
Groundline	lb. (kg)	1840* (830)*	1840* (830)*	2130* (970)*	2130* (970)*	4080* (1850)*	1280 (580)	3130* (1420)*	890 (400)	2340* (1060)*	670 (300)	1870* (850)*	520 (240)	12 ft. 4 in. (3.75 m)	1690* (770)*	460 (210)
-3 ft. (-1.0 m)	lb. (kg)	3720* (1690)*	3720* (1690)*	4650* (2110)*	2210 (1000)	4000* (1810)*	1,290 (580)	2,840* (1290)*	890 (400)	2110* (960)*	660 (300)			10 ft. 5 in. (3.17 m)	1900* (860)*	610 (280)

E26C Long Arm

6 ft. 5 in. (1.9 m) Boom, 4 ft. 5 in. (1.35 m) Arm, Dozer Blade Down

Canopy unit equipped with 0.07 m³ (SAE heaped) bucket, 10 in. (250 mm) rubber track and 545 lb. (247 kg) counterweight.

Load/Lift point height		Load Radius										At Maximum Reach						
		3 ft. (1.0 m)		5 ft. (1.5 m)		7 ft. (2.0 m)		8 ft. (2.5 m)		10 ft. (3.0 m)		12 ft. (3.5 m)		13 ft. (4.0)		Reach ⌀	Capacity	
		end	side	end	side	end	side	end	side	end	side	end	side	end	side		end	side
+10 ft. (3.0 m)	lb. (kg)														11 ft. 3 in. (3.43 m)	1100* (500)*	740 (330)	
Groundline	lb. (kg)	1550* (700)*	1550* (700)*	2050* (930)*	2050* (930)*	4160* (1890)*	1510 (690)	3,040* (1380)*	1060 (480)	2,270* (1030)*	800 (360)	1830* (830)*	630 (280)		13 ft. 1 in. (3.98 m)	1440* (650)*	510 (250)	
-3 ft. (-1.0 m)	lb. (kg)	3100* (1410)*	3100* (1410)*	3950* (1790)*	2550 (1160)	4280* (1940)*	1500 (680)	2990* (1360)*	1040 (470)	2240* (1020)*	780 (360)			11 ft. 3 in. (3.44 m)	1750* (790)*	640 (290)		

NOTE: Lifting capacity are based on ISO 10567.

Lifting capacity does not exceed 75% of tipping load with the machine on firm, level ground or 87% of full hydraulic capacity.

The lift point is a hook located on the back of the bucket.

*Indicates load limited by hydraulic capacity.

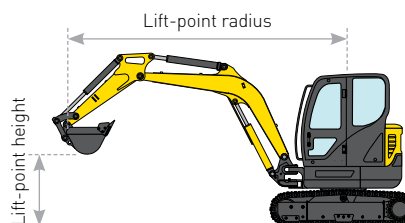

E30C Standard Arm

6 ft. 8 in. (2.03 m) Boom, 3 ft. 8 in. (1.12 m) Arm, Dozer Blade Down

Canopy unit equipped with 0.08 m³ (SAE heaped) bucket, 10 in. (250 mm) rubber track and 772 lb. (350 kg) counterweight.

Load/Lift point height		Load Radius										At Maximum Reach		
		7 ft. (2.0 m)		8 ft. (2.5 m)		10 ft. (3.0 m)		12 ft. (3.5 m)		13 ft. (4.0 m)		Reach ⌀	Capacity	
		end	side	end	side	end	side	end	side	end	side		end	side
+10 ft. (3.0 m)	lb. (kg)					1270* (580)*	1080 (490)					10 ft. 9 in. (3.27 m)	1070* (490)*	920 (420)
Groundline	lb. (kg)	3820* (1730)*	1730 (780)	3170* (1440)*	1210 (550)	2370* (1070)*	920 (420)	1890* (860)*	730 (330)			12 ft. 7 in. (3.84 m)	1460* (660)*	630 (280)
-3 ft. (-1.0 m)	lb. (kg)	4000* (1810)*	1740 (790)	2870* (1300)*	1210 (550)	2150* (980)*	910 (410)					10 ft. 9 in. (3.28 m)	1810* (820)*	800 (360)

E33C Standard Arm

7 ft. 10 in. (2.38 m) Boom, 4 ft. 3 in. (1.3 m) Arm, Dozer Blade Down

Canopy unit equipped with 0.09 m³ (SAE heaped) bucket, 12 in. (300 mm) rubber track and 772 lb. (350kg) counterweight.

Load/Lift point height		Load Radius								At Maximum Reach		
		3 ft. (1.0 m)		7 ft. (2.0 m)		10 ft. (3.0 m)		13 ft. (4.0 m)		Reach ⌀	Capacity	
		end	side	end	side	end	side	end	side		end	side
+10 ft. (3.0 m)	lb. (kg)									12 ft. 10 in. (3.92 m)	1240* (560)*	710 (320)
Groundline	lb. (kg)			4030* (1 830)*	1740 (790)	2880* (1310)*	900 (410)	1890* (860)*	570 (260)	14 ft. 3 in. (4.35 m)	1670* (760)*	490 (220)
-3 ft. (-1.0 m)	lb. (kg)	4470* (2030)*	4470* (2030)*	4940* (2240)*	1760 (800)	2750* (1250)*	890 (400)			12 ft. 8 in. (3.87 m)	1800* (820)*	590 (270)

E37C Standard Arm

8 ft. 2 in. (2.5 m) Boom, 4 ft. 3 in. (1.3 m) Arm, Dozer Blade Down

Canopy unit equipped with 0.11 m³ (SAE heaped) bucket, 12 in. (300 mm) rubber track and 900 lb. (410 kg) counterweight.

Load/Lift point height		Load Radius								At Maximum Reach		
		3 ft. (1.0 m)		7 ft. (2.0 m)		10 ft. (3.0 m)		13 ft. (4.0 m)		Reach ⌀	Capacity	
		end	side	end	side	end	side	end	side		end	side
+10 ft. (3.0 m)	lb. (kg)									12 ft. 11 in. (3.94 m)	1170* (530)*	1070 (490)
Groundline	lb. (kg)			2990* (1320)*	2500 (1130)	2410* (1090)*	1440 (650)	1570* (710)*	920 (420)	14 ft. 11 in. (4.55 m)	1320* (600)*	750 (340)
-3 ft. (-1.0 m)	lb. (kg)	3840* (1740)*	3840* (1740)*	4330* (1960)*	2800 (1270)	2390* (1090)*	1410 (640)	1520* (690)*	910 (410)	13 ft. 8 in. (4.17 m)	1400* (640)*	860 (390)

E37C Long Arm

8 ft. 2 in. (2.5 m) Boom, 5 ft. 3 in. (1.6 m) Arm, Dozer Blade Down

Canopy unit equipped with 0.11 m³ (SAE heaped) bucket, 12 in. (300 mm) rubber track and 1,235 lb. (560 kg) counterweight.

Load/Lift point height		Load Radius								At Maximum Reach		
		3 ft. (1.0 m)		7 ft. (2.0 m)		10 ft. (3.0 m)		13 ft. (4.0 m)		Reach ⌀	Capacity	
		end	side	end	side	end	side	end	side		end	side
+10 ft. (3.0 m)	lb. (kg)							970* (440)*	970* (440)*	14 ft. 2 in. (4.32 m)	970* (440)*	970* (440)*
Groundline	lb. (kg)			3060* (1390)*	3060* (1390)*	2300 lb* (1040)*	1630 (740)	1510* (680)*	1050 (470)	16 ft. 0 in. (4.87 m)	1140* (520)*	760 (350)
-3 ft. (-1.0 m)	lb. (kg)	3040* (1380)*	3040* (1380)*	4610* (2090)*	3090 (1400)	2420* (1100)*	1580 (720)	1560* (710)*	1020 (460)	14 ft. 10 in. (4.52 m)	1250* (570)*	850 (380)

NOTE: Lifting capacity are based on ISO 10567.

Lifting capacity does not exceed 75% of tipping load with the machine on firm, level ground or 87% of full hydraulic capacity.

The lift point is a hook located on the back of the bucket.

*Indicates load limited by hydraulic capacity.

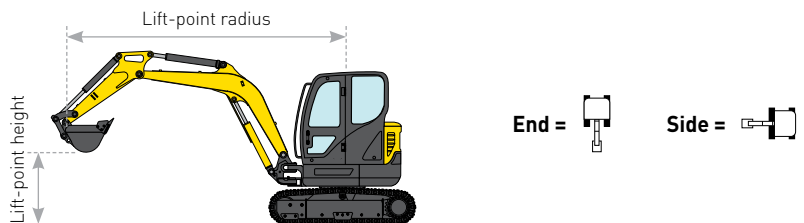

E57C Standard Arm

9 ft. 10 in. (3.0 m) Boom, 5 ft. 3 in. (1.6 m) Arm, Dozer Blade Down

Canopy unit equipped with 0.18 m³ (SAE heaped) bucket, 15 in. (380 mm) rubber track and 518 lb. (235 kg) counterweight.

Load/Lift point height		Load Radius								At Maximum Reach		
		7 ft. (2.0 m)		10 ft. (3.0 m)		13 ft. (4.0 m)		16 ft. (5.0 m)		Reach ⊕	Capacity	
		end	side	end	side	end	side	end	side		end	side
+10 ft. (3.0 m)	lb. (kg)					2340* (1060)*	2100 (950)			16 ft. 3 in. (4.96 m)	2150* (970)*	1400 (630)
Groundline	lb. (kg)	4160* (1890)*	4160* (1890)*	5920* (2680)*	2730 (1240)	3910* (1770)*	1750 (800)	2940* (1330)*	1230 (560)	17 ft. 0 in. (5.17 m)	2820* (1280)*	1160 (530)
-3 ft. (-1.0 m)	lb. (kg)	6870* (3120)*	5430 (2460)	5890* (2670)*	2690 (1220)	3950* (1790)*	1710 (780)			15 ft. 8 in. (4.77 m)	3040* (1380)*	1310 (590)

E57C Long Arm

9 ft. 10 in. (3.0 m) Boom, 6 ft. 3 in. (1.9 m) Arm, Dozer Blade Down

Canopy unit equipped with 0.18 m³ (SAE heaped) bucket, 15 in. (380 mm) rubber track and 739 lb. (335 kg) counterweight.

Load/Lift point height		Load Radius								At Maximum Reach		
		3 ft. (1.0 m)		7 ft. (2.0 m)		10 ft. (3.0 m)		13 ft. (4.0 m)		Reach ⊕	Capacity	
		end	side	end	side	end	side	end	side		end	side
+10 ft. (3.0 m)	lb. (kg)					2070* (940)*	2070* (940)*	2150* (980)*	1500 (680)	17 ft. 3 in. (5.27 m)	1800* (820)*	1350 (610)
Groundline	lb. (kg)	4070* (1840)*	4070* (1840)*	5770* (2620)*	2930 (1330)	3800* (1730)*	1890 (860)	2890* (1310)*	1320 (600)	17 ft. 11 in. (5.46 m)	2360* (1070)*	1140 (520)
-3 ft. (-1.0 m)	lb. (kg)	6160* (2790)*	5720 (2600)	5960* (2700)*	2860 (1300)	3980* (1800)*	1830 (830)	2880* (1310)*	1300 (590)	16 ft. 8 in. (5.08 m)	2800* (1270)*	1260 (570)

E60C Standard Arm

9 ft. 6 in. (2.9 m) Boom, 4 ft. 10 in. (1.48 m) Arm, Dozer Blade Down

Cab unit equipped with 0.18 m³ (SAE heaped) bucket, 15 in. (380 mm) rubber track and 1,036 lb. (470 kg)

Load/Lift point height		Load Radius								At Maximum Reach		
		7 ft. (2.0 m)		10 ft. (3.0 m)		13 ft. (4.0 m)		16 ft. (5.0 m)		Reach ⊕	Capacity	
		end	side	end	side	end	side	end	side		end	side
+10 ft. (3.0 m)	lb. (kg)					2590* (1180)*	1950 (880)			15 ft. 11 in. (4.86 m)	1880* (850)*	1330 (600)
Groundline	lb. (kg)	3610* (1640)*	3610* (1640)*	6560* (2970)*	2540 (1150)	4230* (1920)*	1610 (730)	3110* (1410)*	1120 (510)	16 ft. 8 in. (5.09 m)	2700* (1230)*	1090 (490)
-3 ft. (-1.0 m)	lb. (kg)	6420* (2910)*	5250 (2380)	6290* (2850)*	2510 (1140)	4160* (1890)*	1580 (720)			15 ft. 3 in. (4.65 m)	3260* (1480)*	1250 (570)

E60C Long Arm

9 ft. 6 in. (2.9 m) Boom, 6 ft. 3 in. (1.9 m) Arm, Dozer Blade Down

Cab unit equipped with 0.18 m³ (SAE heaped) bucket, 15 in. (380 mm) rubber track and 1,477 lb. (670 kg) counterweight.

Load/Lift point height		Load Radius								At Maximum Reach		
		7 ft. (2.0 m)		10 ft. (3.0 m)		13 ft. (4.0 m)		16 ft. (5.0 m)		Reach ⊕	Capacity	
		end	side	end	side	end	side	end	side		end	side
+10 ft. (3.0 m)	lb. (kg)					2090* (950)*	2090* (950)*	2130* (960)*	1400 (640)	17 ft. 3 in. (5.27 m)	1380* (620)*	1250 (570)
Groundline	lb. (kg)	3590* (1630)*	3590* (1630)*	6250* (2840)*	2770 (1260)	3990* (1810)*	1760 (800)	2980* (1350)*	1210 (550)	18 ft. 0 in. (5.48 m)	1880* (850)*	1030 (470)
-3 ft. (-1.0 m)	lb. (kg)	5480* (2490)*	5480* (2490)*	6370* (2890)*	2700 (1220)	4150* (1880)*	1700 (770)	2950* (1340)*	1190 (540)	16 ft. 8 in. (5.08 m)	2510* (1140)*	1160 (520)

NOTE: Lifting capacity are based on ISO 10567.

Lifting capacity does not exceed 75% of tipping load with the machine on firm, level ground or 87% of full hydraulic capacity.

The lift point is a hook located on the back of the bucket.

*Indicates load limited by hydraulic capacity.

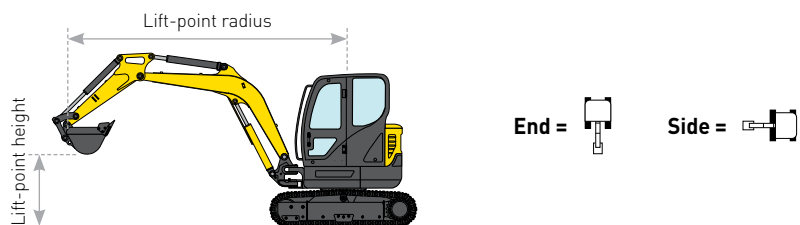

World Class Products Demand World Class Dealers



The purchase of a New Holland machine is just the beginning of our relationship together. Consider your experienced New Holland Construction equipment dealer as your local partner in productivity. Assistance in selecting the right model for your operation and developing an affordable leasing or financing plan through New Holland's financing division, CNH Industrial Capital, are just a few advantages your local dealer can provide.

Your New Holland dealer's full service capabilities bring you responsive support with genuine New Holland parts and all makes

coverage. More importantly, we are there wherever and whenever you need us with our fully equipped service vehicles. From customized maintenance programs to professional operator and technical training, our factory-trained service and parts experts are there to assist you with any of your equipment support needs.

Your business deserves nothing less than world class products supported by a world class business partner. That's your local New Holland Construction equipment dealer — your partner in productivity.



Learn more at www.newholland.com

New Holland Construction
500 Diller Ave.
New Holland, PA 17557

www.newholland.com

Design, materials and/or specifications are subject to change without notice and without liability therefor. Specifications are applicable to units sold in Canada, the United States, its territories and possessions, and may vary outside these areas.

© 2018 CNH Industrial America LLC. All rights reserved. New Holland is a trademark in the United States and many other countries, owned by or licensed to CNH Industrial N.V., its subsidiaries or affiliates. Any trademarks referred to herein, in association with goods and/or services of companies other than CNH America LLC, are the property of those respective companies.



Safety begins with a thorough understanding of the equipment. Always make sure you and your operators read the Operator's Manual before using the equipment. Pay close attention to all safety and operating decals and never operate machinery without all shields, protective devices and structures in place. This is a one-person machine. Never allow riders in the cab, outside the machine, or in/on any bucket or attachment.

NHC3614537 • 061805 • OTP • PRINTED IN U.S.A.

ADDENDUM ACKNOWLEDGEMENT FORM
SOLICITATION NO.:

Instructions: Please acknowledge receipt of all addenda issued with this solicitation by completing this addendum acknowledgment form. Check the box next to each addendum received and sign below. Failure to acknowledge addenda may result in bid disqualification.

Acknowledgment: I hereby acknowledge receipt of the following addenda and have made the necessary revisions to my proposal, plans and/or specification, etc.

Addendum Numbers Received:
(Check the box next to each addendum received)

- Addendum No. 1
- Addendum No. 2
- Addendum No. 3
- Addendum No. 4
- Addendum No. 5

- Addendum No. 6
- Addendum No. 7
- Addendum No. 8
- Addendum No. 9
- Addendum No. 10

I understand that failure to confirm the receipt of addenda may be cause for rejection of this bid. I further understand that any verbal representation made or assumed to be made during any oral discussion held between Vendor's representatives and any state personnel is not binding. Only the information issued in writing and added to the specifications by an official addendum is binding.

THE TRACTOR GUYS LLC

Company

Authorized Signature

1/31/20

Date

NOTE: This addendum acknowledgment should be submitted with the bid to expedite document processing.

DESIGNATED CONTACT: Vendor appoints the individual identified in this Section as the Contract Administrator and the initial point of contact for matters relating to this Contract.

Patrick Holguin Government Account Representative

(Name, Title)

Patrick Holguin Government Account Representative

(Printed Name and Title)

87 wiseman run rd. Salem, WV 26426

(Address)

304-615-6340

(Phone Number) / (Fax Number)

pholguin@parcs.com

(email address)

CERTIFICATION AND SIGNATURE: By signing below, or submitting documentation through wvOASIS, I certify that I have reviewed this Solicitation in its entirety; that I understand the requirements, terms and conditions, and other information contained herein; that this bid, offer or proposal constitutes an offer to the State that cannot be unilaterally withdrawn; that the product or service proposed meets the mandatory requirements contained in the Solicitation for that product or service, unless otherwise stated herein; that the Vendor accepts the terms and conditions contained in the Solicitation, unless otherwise stated herein; that I am submitting this bid, offer or proposal for review and consideration; that I am authorized by the vendor to execute and submit this bid, offer, or proposal, or any documents related thereto on vendor's behalf; that I am authorized to bind the vendor in a contractual relationship; and that to the best of my knowledge, the vendor has properly registered with any State agency that may require registration.

THE TRACTOR GUYS LLC

(Company)

(Authorized Signature) (Representative Name, Title)

Patrick Holguin Government Account Representative

(Printed Name and Title of Authorized Representative)

1/31/20

(Date)

304-782-4111

(Phone Number) (Fax Number)