

**Exhibit A Pricing Page**

**CRFQ DOT1900000117**

**Under Bridge Inspection Vehicle (7019E025)**

Item No.	Description:	Make/Model & Year	Quantity	Unit Price	Item Total Cost
1	One Complete unit: Under Bridge Inspection Vehicle	2020 OR NEWER FREIGHTLINER 122 SD WITH AN ASPEN A52 UNDER BRIDGE INSPECTION BODY	1	\$639,755.00	\$639,755.00
<b>Total Bid Amount</b> 					<b>\$639,755.00</b>

**Vendor Information**

Company Name: Matheny Motor Truck Company

Contract Manager: Jack Cummings

Address: 4125 1st Avenue

Nitro WV, 25143

Phone: 304-769-5860 x 3601

Fax: 304-769-5866

Email: jcummings@mathenymotors.com

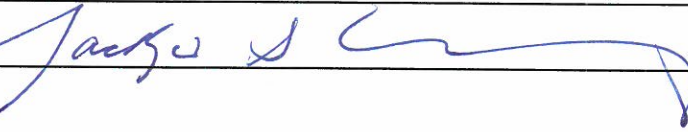
Signature: 

RECEIVED

2019 JUN 27 AM 8: 20

WV PURCHASING  
DIVISION



Purchasing Division  
 2019 Washington Street East  
 Post Office Box 50130  
 Charleston, WV 25305-0130

State of West Virginia  
 Request for Quotation  
 19 - Highways

Proc Folder: 571957

Doc Description: ADDENDUM NO. 4 -Extend bid opening - Under Bridge Inspection

Proc Type: Central Purchase Order

Date Issued	Solicitation Closes	Solicitation No	Version
2019-06-25	2019-06-27 13:30:00	CRFQ 0803 DOT1900000117	5

**BID RECEIVING LOCATION**

BID CLERK  
 DEPARTMENT OF ADMINISTRATION  
 PURCHASING DIVISION  
 2019 WASHINGTON ST E  
 CHARLESTON WV 25305  
 US

**VENDOR**

Vendor Name, Address and Telephone Number:

Matheny Motor Truck Company  
 50 Matheny Lane  
 Mineral Wells WV 26150  
 304-485-4418 x 3601

**FOR INFORMATION CONTACT THE BUYER**

Crystal G Hustead  
 (304) 558-2402  
 crystal.g.hustead@wv.gov

Signature X FEIN # 55-032-0770

DATE June 26, 2019

All offers subject to all terms and conditions contained in this solicitation

**ADDITIONAL INFORMATION:**

\*\*\*ADDENDUM NO. 4\*\*\*

To extend the bid opening from 06/26/2019 to 06/27/2019 at 1:30 pm.

NO OTHER CHANGES AT THIS TIME

INVOICE TO	SHIP TO
DIVISION OF HIGHWAYS EQUIPMENT DIVISION RT 33 83 BRUSHY ROAD CROSSING, PO BOX 610 BUCKHANNON WV26201 US	DIVISION OF HIGHWAYS EQUIPMENT DIVISION 83 BRUSHY FORK RD CROSSING BUCKHANNON WV 26201 US

Line	Comm Ln Desc	Qty	Unit Issue	Unit Price	Total Price
1	UNDER-BRIDGE INSPECTION VEHICLE	1.00000	EA	\$639,755.00	\$639,755.00

Comm Code	Manufacturer	Specification	Model #
25101911	Freightliner	Aspen A52 installed on a Freightliner 122 SD	

**Extended Description :**

UNDER-BRIDGE INSPECTION VEHICLE

**SCHEDULE OF EVENTS**

Line	Event	Event Date
1	MANDATORY PRE-BID MEETING	2019-06-05
2	VENDOR QUESTION DEADLINE	2019-06-10

DOT1900000117	<b>Document Phase</b> Final	<b>Document Description</b> ADDENDUM NO. 4 -Extend bid opening - Under Bridge Inspection	<b>Page 3</b> <b>of 3</b>
---------------	--------------------------------	--	------------------------------

**ADDITIONAL TERMS AND CONDITIONS**

See attached document(s) for additional Terms and Conditions



**ADDENDUM ACKNOWLEDGEMENT FORM**  
**SOLICITATION NO.: DOT1900000117**

**Instructions:** Please acknowledge receipt of all addenda issued with this solicitation by completing this addendum acknowledgment form. Check the box next to each addendum received and sign below. Failure to acknowledge addenda may result in bid disqualification.

**Acknowledgment:** I hereby acknowledge receipt of the following addenda and have made the necessary revisions to my proposal, plans and/or specification, etc.

**Addendum Numbers Received:**

(Check the box next to each addendum received)

- |  |  |
|--|--|
| <input checked="" type="checkbox"/> Addendum No. 1 | <input type="checkbox"/> Addendum No. 6  |
| <input checked="" type="checkbox"/> Addendum No. 2 | <input type="checkbox"/> Addendum No. 7  |
| <input checked="" type="checkbox"/> Addendum No. 3 | <input type="checkbox"/> Addendum No. 8  |
| <input checked="" type="checkbox"/> Addendum No. 4 | <input type="checkbox"/> Addendum No. 9  |
| <input type="checkbox"/> Addendum No. 5            | <input type="checkbox"/> Addendum No. 10 |

I understand that failure to confirm the receipt of addenda may be cause for rejection of this bid. I further understand that any verbal representation made or assumed to be made during any oral discussion held between Vendor's representatives and any state personnel is not binding. Only the information issued in writing and added to the specifications by an official addendum is binding.

Matheny Motor Truck Company

\_\_\_\_\_  
Company

  
\_\_\_\_\_  
Authorized Signature

June 26, 2019

\_\_\_\_\_  
Date

**NOTE:** This addendum acknowledgment should be submitted with the bid to expedite document processing.  
Revised 6/8/2012

**DESIGNATED CONTACT:** Vendor appoints the individual identified in this Section as the Contract Administrator and the initial point of contact for matters relating to this Contract.

Jack Cummings - sales consultant

(Name, Title)

Jack Cummings - sales consultant

(Printed Name and Title)

4125 1st Avenue, Nitro WV 25143

(Address)

304-769-5860 x 3601 304-769-5866

(Phone Number) / (Fax Number)

jcummings@mathenymotors.com

(email address)

**CERTIFICATION AND SIGNATURE:** By signing below, or submitting documentation through wvOASIS, I certify that I have reviewed this Solicitation in its entirety; that I understand the requirements, terms and conditions, and other information contained herein; that this bid, offer or proposal constitutes an offer to the State that cannot be unilaterally withdrawn; that the product or service proposed meets the mandatory requirements contained in the Solicitation for that product or service, unless otherwise stated herein; that the Vendor accepts the terms and conditions contained in the Solicitation, unless otherwise stated herein; that I am submitting this bid, offer or proposal for review and consideration; that I am authorized by the vendor to execute and submit this bid, offer, or proposal, or any documents related thereto on vendor's behalf; that I am authorized to bind the vendor in a contractual relationship; and that to the best of my knowledge, the vendor has properly registered with any State agency that may require registration.

Matheny Motor Truck Company

(Company)



Jack Cummings - sales consultant

(Authorized Signature) (Representative Name, Title)

Jack Cummings - sales consultant

(Printed Name and Title of Authorized Representative)

June 26, 2019

(Date)

304-769-5860 x 3601 304-769-5866

(Phone Number) (Fax Number)



West Virginia Ethics Commission  
**Disclosure of Interested Parties to Contracts**

(Required by W. Va. Code § 6D-1-2)

Contracting Business Entity: Matheny Motor Truck Co. Address: PO Box 1304

Authorized Agent: M J Matheny Address: Parkersburg WV 26102-1304

Contract Number: CRFQ 0803 DOT1900000117 Contract Description: Under-Bridge Inspection Vehicle

Governmental agency awarding contract: WV DOH

Check here if this is a Supplemental Disclosure

List the Names of Interested Parties to the contract which are known or reasonably anticipated by the contracting business entity for each category below (attach additional pages if necessary):

**1. Subcontractors or other entities performing work or service under the Contract**

Check here if none, otherwise list entity/individual names below.

Aspen Aerials - 4303 West 1st Street, Duluth MN 55807

**2. Any person or entity who owns 25% or more of contracting entity (not applicable to publicly traded entities)**

Check here if none, otherwise list entity/individual names below.

**3. Any person or entity that facilitated, or negotiated the terms of, the applicable contract (excluding legal services related to the negotiation or drafting of the applicable contract)**

Check here if none, otherwise list entity/individual names below.

Signature: M. J. Matheny CEO Date Signed: 6/24/2019

**Notary Verification**

State of West Virginia, County of Wood:

I, M J Matheny, the authorized agent of the contracting business entity listed above, being duly sworn, acknowledge that the Disclosure herein is being made under oath and under the penalty of perjury.

Taken, sworn to and subscribed before me this 24th day of June, 2019.

Michelle L. White  
Notary Public's Signature

**To be completed by State Agency:**

Date Received by State Agency: \_\_\_\_\_

Date submitted to Ethics Commission: \_\_\_\_\_

Governmental agency submitting Disclosure: \_\_\_\_\_

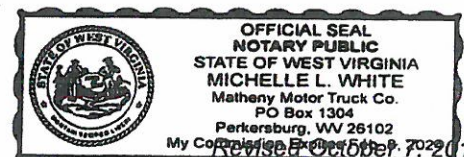



STATE OF WEST VIRGINIA  
Purchasing Division  
**PURCHASING AFFIDAVIT**

**CONSTRUCTION CONTRACTS:** Under W. Va. Code § 5-22-1(i), the contracting public entity shall not award a construction contract to any bidder that is known to be in default on any monetary obligation owed to the state or a political subdivision of the state, including, but not limited to, obligations related to payroll taxes, property taxes, sales and use taxes, fire service fees, or other fines or fees.

**ALL CONTRACTS:** Under W. Va. Code §5A-3-10a, no contract or renewal of any contract may be awarded by the state or any of its political subdivisions to any vendor or prospective vendor when the vendor or prospective vendor or a related party to the vendor or prospective vendor is a debtor and: (1) the debt owed is an amount greater than one thousand dollars in the aggregate; or (2) the debtor is in employer default.

**EXCEPTION:** The prohibition listed above does not apply where a vendor has contested any tax administered pursuant to chapter eleven of the W. Va. Code, workers' compensation premium, permit fee or environmental fee or assessment and the matter has not become final or where the vendor has entered into a payment plan or agreement and the vendor is not in default of any of the provisions of such plan or agreement.

**DEFINITIONS:**

"Debt" means any assessment, premium, penalty, fine, tax or other amount of money owed to the state or any of its political subdivisions because of a judgment, fine, permit violation, license assessment, defaulted workers' compensation premium, penalty or other assessment presently delinquent or due and required to be paid to the state or any of its political subdivisions, including any interest or additional penalties accrued thereon.

"Employer default" means having an outstanding balance or liability to the old fund or to the uninsured employers' fund or being in policy default, as defined in W. Va. Code § 23-2c-2, failure to maintain mandatory workers' compensation coverage, or failure to fully meet its obligations as a workers' compensation self-insured employer. An employer is not in employer default if it has entered into a repayment agreement with the Insurance Commissioner and remains in compliance with the obligations under the repayment agreement.

"Related party" means a party, whether an individual, corporation, partnership, association, limited liability company or any other form or business association or other entity whatsoever, related to any vendor by blood, marriage, ownership or contract through which the party has a relationship of ownership or other interest with the vendor so that the party will actually or by effect receive or control a portion of the benefit, profit or other consideration from performance of a vendor contract with the party receiving an amount that meets or exceeds five percent of the total contract amount.

**AFFIRMATION:** By signing this form, the vendor's authorized signer affirms and acknowledges under penalty of law for false swearing (W. Va. Code §61-5-3) that: (1) for construction contracts, the vendor is not in default on any monetary obligation owed to the state or a political subdivision of the state, and (2) for all other contracts, that neither vendor nor any related party owe a debt as defined above and that neither vendor nor any related party are in employer default as defined above, unless the debt or employer default is permitted under the exception above.

**WITNESS THE FOLLOWING SIGNATURE:**

Vendor's Name: Matheny Motor Truck Company

Authorized Signature: *[Signature]*

Date: June 26, 2019

State of WV

County of Kanawha, to-wit:

Taken, subscribed, and sworn to before me this 26<sup>th</sup> day of June, 2019.

My Commission expires December 25, 2023, 20  .

**AFFIX SEAL HERE**

**NOTARY PUBLIC** *Monica C. Whitt*

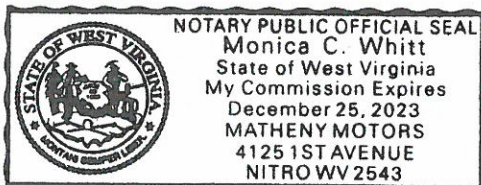

*Purchasing Affidavit (Revised 01/19/2018)*



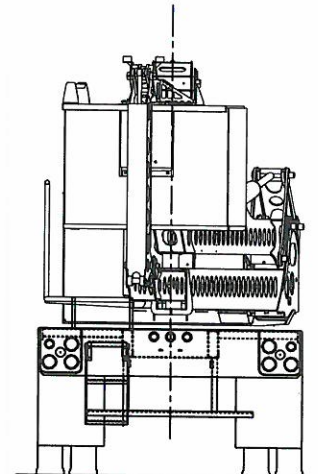
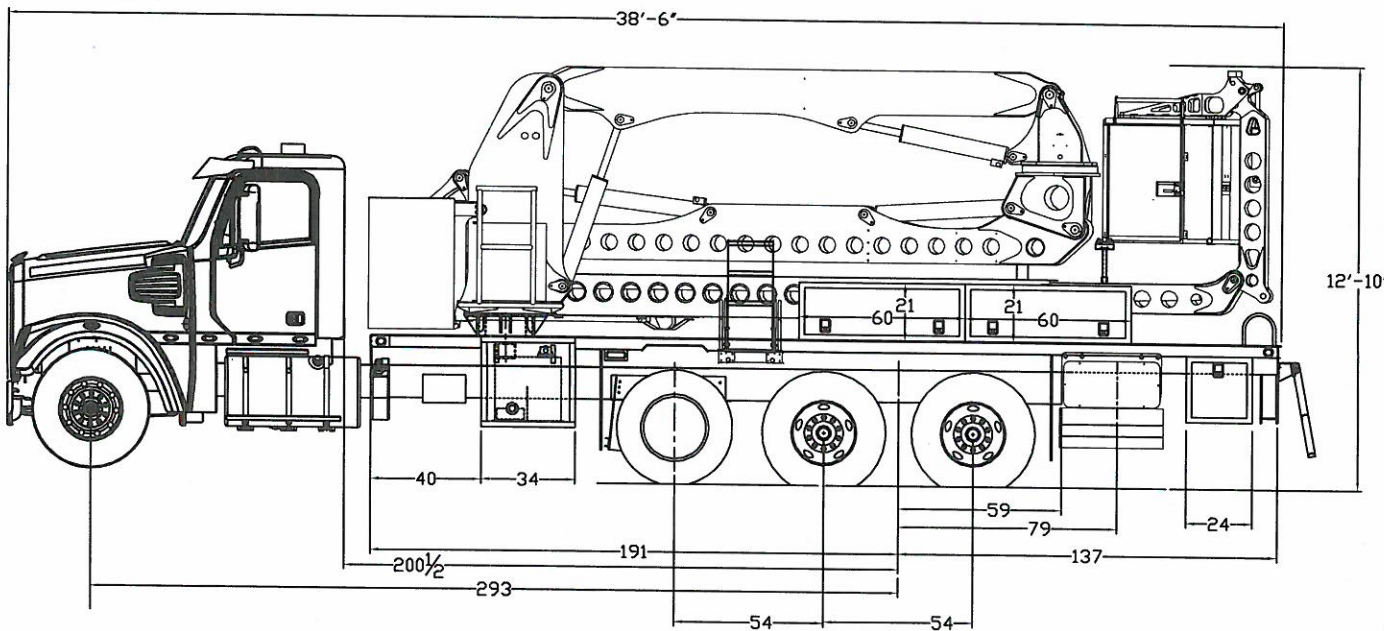
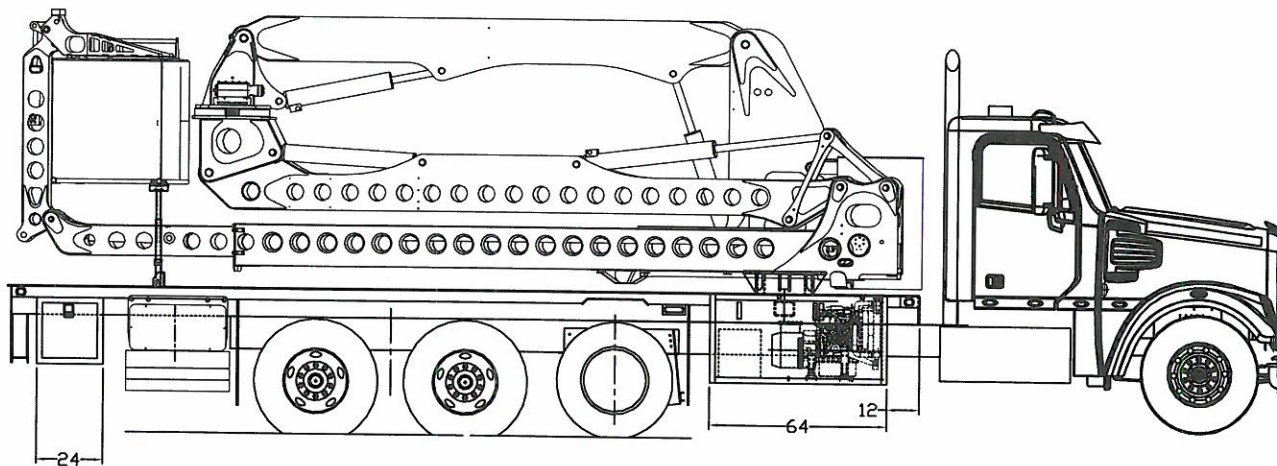

**AXLE WEIGHTS**

LIFT AXLE DOWN 17,686 LB  
 LIFT AXLE RAISED 20,141 LB

TOTAL WEIGHT  
 57,770 LB

8,500 LB      15,792 LB      15,792 LB  
 18,815 LB      18,815 LB

CHASSIS: FREIGHTLINER 122SD SFA

DO NOT SCALE THIS DRAWING

UNLESS OTHERWISE SPECIFIED  
 DIMENSIONS ARE IN INCHES  
 DIMENSIONS IN PARENTHESES ARE IN MILLIMETERS  
 DIMENSIONS IN QUOTES ARE QUOTE UNQUOTE AS SHOWN ON DRAWING

**ASPEN AERIALS** INC.  
 1000 WEST VIRGINIA AVENUE  
 MARTINSBURG, WV 26101

GENERAL ARRANGEMENT A52  
 WEST VIRGINIA DDH

DATE BY CLARK 4-12-10  
 D A52 WV

REV	DESCRIPTION	BY	DATE



# ASPEN A-52

Bridge Inspection Unit

## Inspection and Maintenance

**Design.....**The Aspen A-52 was designed as a dual functioning machine, one that can be used for both inspection and maintenance tasks. With the articulating boom installed, inspectors have the flexibility to inspect all areas of the bridge; above, below and 53' horizontally under. An interchangeable 1,500 capacity work platform can be installed for those heavy duty tasks, when you need additional room and extra tools to complete your work.

**Accessories.....** The Aspen A-52 can be equipped to assist you in your job. Air, 110 or 220V power, water lines, hydraulic tool circuit or welding cables can be routed to the platform for your use. The job can be finished in less time because the tools are there for you.

**Stabilization.....**Outriggers are not required and all counterweights stay within the width of the truck body. A sliding counterweight is installed and operates to either side while the Aspen A-52 is deployed to the opposite side.



### Interchangeable Platforms



Two platform options are available. Either a telescoping boom with an articulating 4th boom and inspection platform, or a 1,500 lb 3-stage walkway can be installed.



### Advanced Control System



As the most advanced microprocessor control system available, the "Plus 1" Graphical Terminal Interface includes a color display depicting unit operation and individual function performance while monitoring the unit's parameters, hydraulics and enabling simple troubleshooting. Wireless controls are included at both operator stations. A communication system is also provided with speakers in the cab, at the turntable, and in the platform. The platform station operates in the "hands-free" mode.

### Easy Deployment through cables and trusses



Whether you have the telescoping boom or walkway installed, the Aspen A-52 can easily maneuver around cables and steel truss members.







**Standard Equipment**

- Plus 1 Graphic Terminal Interface
- Hydraulically adjustable turntable
- Automatic leveling platform: 40" x 60" (1016mm x 1524mm), 600lb. (272kg.) capacity w/access gate
- 2 sets of wireless controls: one set in the platform and one set at the pedestal
- 4 articulating booms (3rd boom telescope); 2 rotating turrets
- Stability interlocks with monitoring system
- Two power systems: power take-off from the truck's transmission and a back-up diesel power unit
- 12-volt intercom system between platform, driver's compartment and pedestal

Options include air, electric and water lines

Horizontal Underbridge Reach	53' / 16.1m
Vertical Reach Down	57'-6" / 17.6m
Vertical Reach Up	44' / 13.4m
Boom no. 1 movement	+30 to - 35
Boom no. 2 movement	+ 0 to -105
Boom no. 3 movement	+90 to - 60
Boom no. 4 movement	+90 to - 34
Space Required on Bridge	102" / 2.5m
Basket Capacity	600 lbs. / 272 kg.
Basket Size	40" x 60" x 42" 101cm x 152cm
Overall Length	39' / 11.9m *
Overall Height	12'-10" / 3.9m *

\*May vary depending on chassis

**Aspen Aerials, Inc.**  
 4303 West 1st Street  
 Duluth, MN 55807

Phone: 218-624-1111  
 Toll Free: 800-888-2773  
 Fax: 218-624-1714  
 Web site: [www.aspenaerials.com](http://www.aspenaerials.com)



# Specifications

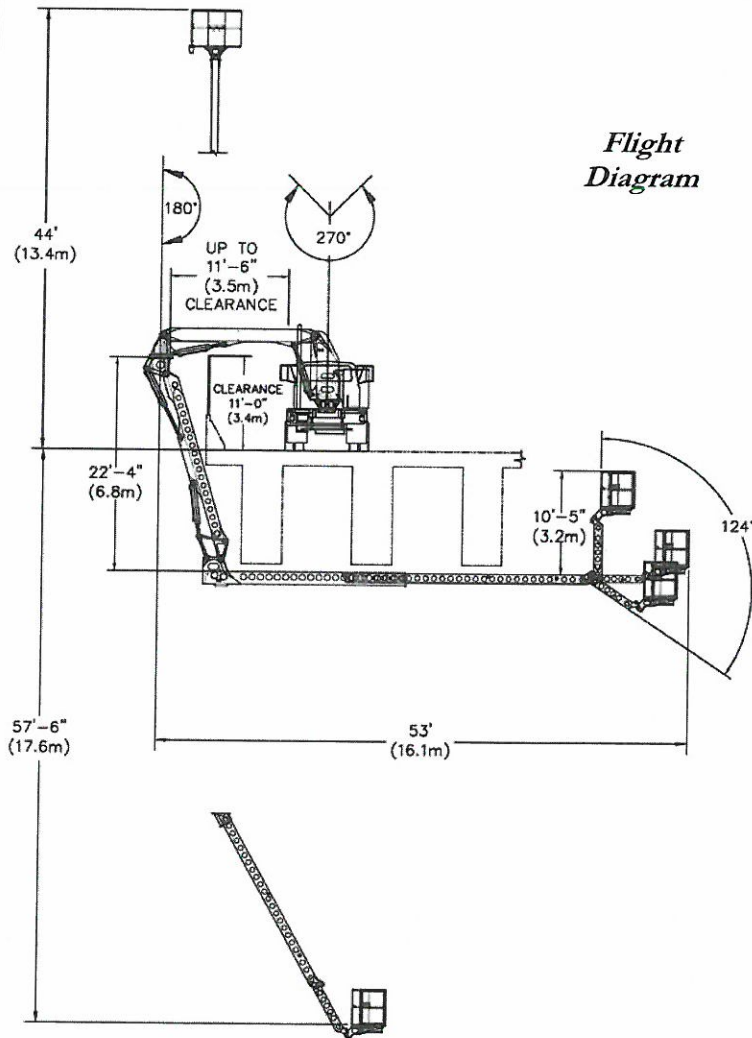

# Platform Features

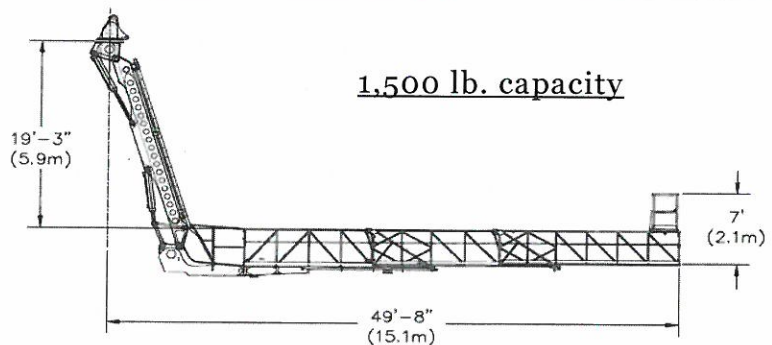

The Aspen A-52 can be equipped with an interchangeable work platform. This 43' long steel walkway can extend close to 50' horizontally under the bridge. It is kept level by means of a hydraulic leveling system and comes equipped with a "step up" platform for access behind deep girders. Wireless controls enable the workers to move the unit from anywhere along the platform.