



The following documentation is an electronically-submitted vendor response to an advertised solicitation from the *West Virginia Purchasing Bulletin* within the Vendor Self-Service portal at *wvOASIS.gov*. As part of the State of West Virginia's procurement process, and to maintain the transparency of the bid-opening process, this documentation submitted online is publicly posted by the West Virginia Purchasing Division at *WVPurchasing.gov* with any other vendor responses to this solicitation submitted to the Purchasing Division in hard copy format.

Header 4

General Information

Contact

Default Values

Discount

Document Information

Procurement Folder: 558157

Procurement Type: Central Purchase Order

Vendor ID: 000000200158

Legal Name: WV ELECTRIC SUPPLY CO

Alias/DBA:

Total Bid: \$53,255.32

Response Date: 04/04/2019

Response Time: 12:49

SO Doc Code: CRFQ

SO Dept: 0211

SO Doc ID: GSD1900000019

Published Date: 3/29/19

Close Date: 4/4/19

Close Time: 13:30

Status: Closed

Solicitation Description: Addendum 1 - Energy Savings -
Lights Project[Apply Default Values to Commodity Lines](#)[View Procurement Folder](#)



Purchasing Division
 2019 Washington Street East
 Post Office Box 50130
 Charleston, WV 25305-0130

**State of West Virginia
 Solicitation Response**

Proc Folder : 558157
Solicitation Description : Addendum 1 - Energy Savings - Lights Project
Proc Type : Central Purchase Order

Date issued	Solicitation Closes	Solicitation Response	Version
	2019-04-04 13:30:00	SR 0211 ESR04041900000004581	1

VENDOR
000000200158 WV ELECTRIC SUPPLY CO

Solicitation Number: CRFQ 0211 GSD1900000019

Total Bid : \$53,255.32 **Response Date:** 2019-04-04 **Response Time:** 12:49:06

Comments:

FOR INFORMATION CONTACT THE BUYER
 Linda B Harper
 (304) 558-0468
 linda.b.harper@wv.gov

Signature on File	FEIN #	DATE
--------------------------	---------------	-------------

All offers subject to all terms and conditions contained in this solicitation

Line	Comm Ln Desc	Qty	Unit Issue	Unit Price	Ln Total Or Contract Amount
1	Light emitting diode LED fixture	37.00000	EA	\$162.000000	\$5,994.00

Comm Code	Manufacturer	Specification	Model #
39111544			

Extended Description : 3.1.1 Barron Lighting Group, Trace Lite RCL Series, or equal.

Line	Comm Ln Desc	Qty	Unit Issue	Unit Price	Ln Total Or Contract Amount
2	Light emitting diode LED fixture	41.00000	EA	\$237.710000	\$9,746.11

Comm Code	Manufacturer	Specification	Model #
39111544			

Extended Description : 3.1.2 Metalux Cruz Series, AMSEM 24CZ-LD5-40SE-S-UNV-EL7W-L835-CD1-SVPD1-RV-U, or equal.

Line	Comm Ln Desc	Qty	Unit Issue	Unit Price	Ln Total Or Contract Amount
3	Light emitting diode LED fixture	30.00000	EA	\$223.000000	\$6,690.00

Comm Code	Manufacturer	Specification	Model #
39111544			

Extended Description : 3.1.3 Metalux Cruz Series AMSEGEN 24CZ-LD5-40SE-S-UNV-ETRD-L835-CD1-SVPD1-DV-U, or equal.

Line	Comm Ln Desc	Qty	Unit Issue	Unit Price	Ln Total Or Contract Amount
4	Interior lighting fixtures and accessories	8.00000	EA	\$72.870000	\$582.96

Comm Code	Manufacturer	Specification	Model #
39111500			

Extended Description : 3.1.4 Greengate OXC-P extreme temperature sensors, or equal.

Line	Comm Ln Desc	Qty	Unit Issue	Unit Price	Ln Total Or Contract Amount
5	Light emitting diode LED fixture	155.00000	EA	\$118.000000	\$18,290.00

Comm Code	Manufacturer	Specification	Model #
39111544			

Extended Description : 3.1.5 Metalux Cruz series Type AMS 24CZ-LD5-40SE-S-UNV-L835-CDI-SVPD1-DV-U, or equal.

Line	Comm Ln Desc	Qty	Unit Issue	Unit Price	Ln Total Or Contract Amount
6	Light emitting diode LED fixture	45.00000	EA	\$62.290000	\$2,803.05

Comm Code	Manufacturer	Specification	Model #
39111544			

Extended Description : 3.1.6 Metalux Cruz Series 22CZ-LD5-39E-S_UNV-L835-CD1-U, or equal.

Line	Comm Ln Desc	Qty	Unit Issue	Unit Price	Ln Total Or Contract Amount
7	Interior lighting fixtures and accessories	100.00000	EA	\$47.120000	\$4,712.00

Comm Code	Manufacturer	Specification	Model #
39111500			

Extended Description : 3.1.7 COOPER/EATON controller OSW-P-010, or equal.

Line	Comm Ln Desc	Qty	Unit Issue	Unit Price	Ln Total Or Contract Amount
8	Interior lighting fixtures and accessories	200.00000	EA	\$0.910000	\$182.00

Comm Code	Manufacturer	Specification	Model #
39111500			

Extended Description : 3.1.8 Seismic Lighting Fixture Clamp, COOPER EATON EQ-CLIP-U, or equal.

Line	Comm Ln Desc	Qty	Unit Issue	Unit Price	Ln Total Or Contract Amount
9	Interior lighting fixtures and accessories	40.00000	EA	\$106.380000	\$4,255.20

Comm Code	Manufacturer	Specification	Model #
39111500			

Extended Description :	3.1.9 Hubbell ATP 1500C motion detector w/Acuity Sensor switch Low 35 Power relay included, or equal.
-------------------------------	---

H-MOSS® Controls Adaptive Technology Passive Infrared Ceiling Sensors

HUBBELL



Features

- Coverage 1500 sq. ft. (360°) with photocell and isolated relay, low voltage sensor
- Long range major motion detection
- Office White ABS enclosure blends with ceiling tile
- Relay to interface with auxiliary systems such as HVAC
- Red LED indicates passive infrared detection
- "Install and Forget" operation. Auto-adjusting adaptive technology eliminates manual adjustments



Ordering Information

Description	Device Color	UPC Number	Catalog Number
Low voltage sensor with photocell and isolated relay	Office White	783585392523	ATP1500CRP

Listings

cULus listed to UL244A
ASHRAE 90.1 compliant
CEC Title 24 compliant

Specifications

Housing	Flame retardant UL 94 V-0 ABS
Lens	Polyethylene
Dimensions	1.5"H x 4.5"D
Mounting Height	8 to 12 feet

Performance

Controls

Ambient Light	1 to 1000 foot candles
Sensitivity	Adaptive 0 to 100%
Time Delay	Test (8 seconds), adaptive 8 to 40 minutes

Electrical

Isolated Relay	Normally open and normally closed terminals available
Power Requirements	24V DC nominal, 33mA from Hubbell CU series control unit

Environmental

Operating Temperature	32°F to 104°F (0°C to 40°C) with rate of change not exceeding 20°F (11°C) per hour
Storage Temperature	-20°F to 150°F (-29°C to 65°C); 0% to 95% non-condensing relative humidity

Sensing Indicators

Passive Infrared	Red LED
------------------	---------

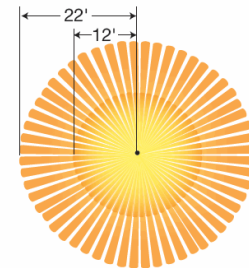
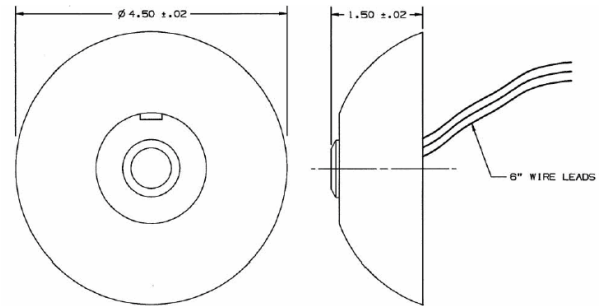

Complementary Products

Control Unit Auto-ON	CU300A
Control Unit Manual-ON	CU300M
Control Unit, HD, Latching, Auto/Manual-ON	CU300HD
Ceiling sensor NEMA 4X enclosure	ACIPE
Ceiling mount raceway adapter	ACMRA

Online Resources

Customer Use Drawing
eCatalog
Installation Instructions

Hubbell will not warrant their product if using another brand of power relay with it. It voids the UL.

Dimensions in Inches (mm)

Hubbell Wiring Device-Kellems • Hubbell Incorporated (Delaware) • 40 Waterview Drive • Shelton, CT 06484

Phone (800) 288-6000 • Fax (800) 255-1031 • Specifications subject to change without notice.





Features

- Automatic ON operation
- Automatic Voltage Detection eliminates the need for specialized wiring
- Zero Arc Point Switching Minimizes relay contact
- Easily mounts inside or outside a junction box or inside a fluorescent fixture ballast cavity.
- Plenum rated

Ordering Information

Description	Device Color	UPC Number	Catalog Number
Automatic-on operation, 120/277V AC, 50/60Hz	Black	783585181004	CU300A



Listings

cULus listed to UL 916
UL2043 plenum rated per NEC® 2014 300.22(C)(3)
ASHRAE 90.1 compliant

Specifications

Housing	Flame retardant UL 94-5VA thermoplastic
Dimensions	3.69"L x 2.33"W x 1.36"H

Performance

Electrical

AT Sensor/AAR Capacity	1 to 4 combined
Load Capacity	Incandescent - 0 to 1800 watts, 120V Ballast- 0 to 2400 watts, 277V Ballast- 0 to 5540 watts
Power Output	24V DC, 150mA
Power Supply	120-277V AC, 50/60Hz

Environmental

Operating Temperature	32°F to 104°F (0°C to 40°C); 0% to 90% non condensing relative humidity
Storage Temperature	-20°F to 150°F (-29°C to 65°C); 0% to 90% non condensing relative humidity

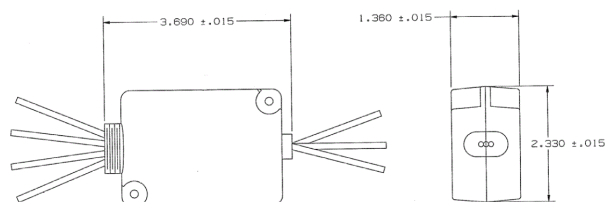

Complementary Products

Add-A-Relay AAR

Online Resources

Customer Use Drawing
eCatalog
Installation Instructions



HUBBELL
Control Solutions

HUBBELL CONTROL SOLUTIONS LIMITED WARRANTY

Limited Warranty (“Warranty”): Subject to the exclusions set forth below, Hubbell Building Automation, Inc. (now known as Hubbell Control Solutions (“HCS”)) warrants that the HCS branded occupancy sensors, daylight controls, lighting control panels, network devices and related products (collectively, “Products”) will be free from defects in material and workmanship for a period of five (5) years from the date of the certificate of building occupancy or proof of installation, whichever occurs first (“Warranty Period”). If the certificate of building occupancy is not available or there is no proof of installation, the Warranty Period shall begin with the Product shipment date.

Exclusions: This Warranty only covers Product function and does not cover existing building and/or network performance or limitations or any Product re-programming or field adjustments done by anyone that has not been authorized or certified in writing by HCS. Products that are identified by HCS as requiring on-site commissioning will only be covered by this Warranty if commissioned by HCS-certified personnel. Warranty coverage shall not apply to any equipment or integration services of another manufacturer used in conjunction with HCS Products or where factory-authorized cables are not used.

This Warranty applies only when the Products have been properly handled, stored, wired, transported, installed, operated and maintained in accordance with the applicable Specifications, including, without limitation, installation in applications in which ambient temperatures are within the range of specified operating temperatures and operation within the electrical values shown on the Specifications. HCS shall have no responsibility under this Warranty for any failure of the Products that results from external causes including without limitation: acts of nature; physical damage; exposure to adverse or hazardous chemicals or other substances; use of reactive cleaning agents and/or harsh chemicals to clean the Products; environmental conditions; vandalism; fire; power failure, improper power supply, power surges or dips, and/or excessive switching; fatigue failure or similar phenomena resulting from induced vibrations, harmonic oscillation or resonance associated with movement of air currents around the Product; animal or insect activity; fault or negligence of the purchaser of the Products, any end user of the Products and/or any third parties not engaged by HCS, improper or unauthorized use, installation, handling, storage, alteration, maintenance or service, including failure to abide by any product classifications or certifications, or failure to comply with any applicable standards, codes, recommendations, product specification sheets, use of Products with products, processes or materials supplied by the purchaser of the Products, any end user or third parties, or any other occurrences beyond HCS's reasonable control. In addition, HCS shall have no responsibility under this Warranty for any substantial deterioration in the Product finish that is caused by failure to clean, inspect or maintain the finish of the Products. During the Warranty Period some staining, chalking or fading may occur. This is normal aging of the finish and is not a manufacturing defect; therefore it is not covered by this Warranty. Neither polycarbonate nor acrylic material used in the Products is warranted against yellowing, as yellowing may naturally occur over time due to normal aging. If the Products are used on existing foundations, anchorages or structures, the purchaser of the Products and/or any end user is solely responsible for the structural integrity of such existing foundations, anchorages or structures and all consequences arising from their use.

Adequate records (as determined by HCS in its sole discretion) of operating history, maintenance, and/or testing must be kept by the end user and provided to HCS upon request to substantiate that the Products have failed to comply with the terms of this Warranty. The Products are not warranted against costs that may be incurred in connection with changes or modifications to the Products required to accommodate site conditions and/or faulty building construction or design. In addition, the Products are not warranted against cost resulting from installation of third party components, failures of third party supplied components, or failures of HCS supplied Products caused by third party supplied components. This Warranty is not applicable to any product(s) which are not installed and operated in accordance with the current edition of The National Electric Code (NEC), the Standards for Safety of Underwriters’ Laboratory, Inc. (UL), or the standards for the American National Standards Institute (ANSI), and with HCS instructions and guidelines for the Product. THIS WARRANTY IS VOID WITH RESPECT TO ANY PRODUCT IF THE PRODUCT IS NOT USED FOR THE PURPOSE FOR WHICH IT WAS DESIGNED OR IF ANY REPAIRS OR ALTERATIONS ARE MADE BY ANY PERSON NOT AUTHORIZED BY HCS IN WRITING.

Except as otherwise set forth herein, HCS does not warrant emergency batteries/inverters, replaceable consumables (such as printers or cartridges), computer hardware, mobile computing devices, software (other than firmware), commissioning systems, third party gear, and installation services, remote programming, professional services and other third party devices that are not manufactured by HCS, which are covered by the applicable third party manufacturer warranty (if any). Such third party manufacturer shall be solely responsible for the costs related to any claims associated with any such devices. Emergency batteries/inverters, occupancy sensors, daylight controls, lighting control panels and networked devices provided by Hubbell Lighting, Inc. are warranted separately; the terms of such warranties are located at www.hubbellighting.com/resources/warranty.

Remedy: If the Product(s) fail to comply with the terms of this Warranty and the end user (and the purchaser of the Product(s) if different from the end user) has fully complied with all of the obligations under this Warranty and the Terms and Conditions of Sale for Hubbell Lighting, Inc. (which are available at www.hubbellighting.com/terms_and_conditions) including, without limitation, payment in full in respect of the Products, HCS, at its sole option, will repair or replace the Product(s) with the same or a functionally equivalent Product(s) or component part(s). Specifically, HCS will repair the Product, replace with a similar or like Product (as determined by HCS in its sole discretion), or issue a credit to the purchaser which may be used for future HCS product purchases. (The amount of such credit shall be calculated by HCS at its sole discretion). HCS reserves the right to use new, reconditioned, refurbished, repaired or remanufactured products or parts in the repair or replacement of any Product covered by this Warranty. This Warranty excludes any and all removal or reinstallation costs and expenses including, without limitation, labor and equipment required to remove and/or reinstall original or replacement Product(s) or parts, shipping costs to return nonconforming Products(s) or any damage that may occur during the return of any Product(s) to HCS. This Warranty only extends to the Products as delivered to, and is for the sole and exclusive benefit of, the end user of the Products at the original location. HCS reserves the right to use new, reconditioned, refurbished, repaired or remanufactured products or parts in the repair or replacement of any Product covered by this Warranty. This Warranty may not be transferred or assigned by the end user. The repair, issuing of future purchase credit or replacement of any Products or component part within the Products is the sole and exclusive remedy for failure of the Products to comply with the terms of this Warranty and does not extend the Warranty period. Warranty claims regarding Products must be submitted in writing within thirty (30) days of discovery of the defect or failure to an authorized HCS customer service representative. Products or component parts may be required to be returned for inspection and verification of non-conformance by HCS, but no Products or component parts will be accepted for inspection, verification or return unless accompanied by a completed return materials authorization form which can be obtained only from an authorized HCS customer service representative. HCS is not responsible for any costs and expenses incurred in connection with the shipment of Products to HCS, but HCS shall bear all cost and expense incurred in connection with the shipment of replacement Products to the end user.

NO OTHER WARRANTIES: THE FOREGOING WARRANTY TERMS ARE EXCLUSIVE AND IN LIEU OF ALL OTHER WARRANTIES AND HCS EXPRESSLY DISCLAIMS ANY AND ALL OTHER WARRANTIES, EXPRESS OR IMPLIED RELATING DIRECTLY OR INDIRECTLY TO THE PRODUCT(S), WHETHER ORAL, WRITTEN, OR ARISING BY COURSE OF DEALING OR USAGE OF TRADE, INCLUDING, WITHOUT LIMITATION, ANY WARRANTIES OF MERCHANTABILITY OR FITNESS FOR A PARTICULAR PURPOSE. NO ORAL OR WRITTEN INFORMATION OR ADVICE GIVEN BY HCS OR ANY EMPLOYEE, AGENT, DISTRIBUTOR OR OTHER SUPPLIER OF HCS PRODUCTS SHALL CREATE A WARRANTY OR IN ANY WAY INCREASE THE SCOPE OF THE WARRANTY. NO EMPLOYEE, AGENT, DISTRIBUTOR OR OTHER SUPPLIER OF HCS PRODUCTS HAS THE AUTHORITY TO MODIFY OR AMEND THIS WARRANTY WITHOUT EXPRESS WRITTEN AUTHORIZATION FROM HCS.

LIMITATION OF LIABILITY: IN NO EVENT SHALL HCS'S TOTAL LIABILITY IN RESPECT OF ANY AND ALL CLAIMS OF ANY KIND WHETHER IN CONTRACT, WARRANTY, TORT (INCLUDING NEGLIGENCE), STRICT LIABILITY OR OTHERWISE ARISING OUT OF OR IN CONNECTION WITH, OR RESULTING FROM HCS'S PERFORMANCE OR BREACH OF THIS WARRANTY, OR FROM HCS'S SALE, DELIVERY, RESALE, REPAIR, OR REPLACEMENT OF ANY PRODUCT(S) OR THE FURNISHING OF ANY SERVICE, EXCEED THE PURCHASE PRICE ALLOCABLE TO THE PRODUCT(S) THAT GIVE RISE TO THE CLAIM, AND ANY AND ALL SUCH LIABILITY SHALL TERMINATE UPON THE EXPIRATION OF THE WARRANTY PERIOD. IN NO EVENT SHALL HCS BE LIABLE FOR ANY INDIRECT, SPECIAL, INCIDENTAL, CONSEQUENTIAL, EXEMPLARY, MULTIPLE OR PUNITIVE DAMAGES, EVEN IF INFORMED OF THE POSSIBILITY OF SUCH DAMAGES, WHETHER AS THE RESULT OF BREACH OF CONTRACT, WARRANTY, TORT (INCLUDING NEGLIGENCE), STRICT LIABILITY OR ANY OTHER THEORY, INCLUDING WITHOUT LIMITATION LABOR OR EQUIPMENT REQUIRED TO REMOVE AND/OR REINSTALL ORIGINAL OR REPLACEMENT PARTS, LOSS OF TIME, PROFITS OR REVENUES, LACK OR LOSS OF PRODUCTIVITY, LOSS OF USE OF THE PRODUCT(S) OR ANY ASSOCIATED EQUIPMENT, INTEREST CHARGES OR COST OF CAPITAL, COST OF SUBSTITUTE EQUIPMENT, FACILITIES, SYSTEMS, SERVICES OR DOWNTIME COSTS, DAMAGE TO OR LOSS OF PROPERTY OR EQUIPMENT, ANY INCONVENIENCE, COST OR DAMAGE ARISING OUT OF ANY DELAY IN PERFORMING, FAILURE TO PERFORM OR OTHER BREACH OF THE FOREGOING WARRANTY OR OBLIGATIONS UNDER SUCH WARRANTY, OR CLAIMS OF THIRD PARTIES AGAINST THE PURCHASER OF THE PRODUCTS OR THE END USER, ARISING OUT OF OR IN CONNECTION WITH THE SALE, INSTALLATION, USE OF, INABILITY TO USE, OR THE REPAIR OR REPLACEMENT OF THE PRODUCTS.

Right to Modify or Discontinue Warranty: This Warranty is effective for the purchases of Products on or after the effective date set forth herein and is in consideration of and is expressly subject to and conditioned by the terms set forth herein. HCS reserves the right to modify or discontinue this Warranty without notice provided that any such modification or discontinuance will only be effective with respect to any Products purchased after such modification or discontinuance.

DESIGNATED CONTACT: Vendor appoints the individual identified in this Section as the Contract Administrator and the initial point of contact for matters relating to this Contract.

Judy Lang Quotation Job Manager
(Name, Title)
Judy LANG Quotations / Job MANAGER
(Printed Name and Title)
250 12th St West Huntington, WV 25704
(Address)
304-399-4523 304-522-1454
(Phone Number) / (Fax Number)
judy.lang@wvsupply.com
(email address)

CERTIFICATION AND SIGNATURE: By signing below, or submitting documentation through wvOASIS, I certify that I have reviewed this Solicitation in its entirety; that I understand the requirements, terms and conditions, and other information contained herein; that this bid, offer or proposal constitutes an offer to the State that cannot be unilaterally withdrawn; that the product or service proposed meets the mandatory requirements contained in the Solicitation for that product or service, unless otherwise stated herein; that the Vendor accepts the terms and conditions contained in the Solicitation, unless otherwise stated herein; that I am submitting this bid, offer or proposal for review and consideration; that I am authorized by the vendor to execute and submit this bid, offer, or proposal, or any documents related thereto on vendor's behalf; that I am authorized to bind the vendor in a contractual relationship; and that to the best of my knowledge, the vendor has properly registered with any State agency that may require registration.

WV Electroc Supply
(Company)
Tony Barber VP
(Authorized Signature) (Representative Name, Title)
Tony Barber VP
(Printed Name and Title of Authorized Representative)
4/3/19
(Date)
304-525-0361 Fax 304-522-1454
(Phone Number) (Fax Number)

ADDENDUM ACKNOWLEDGEMENT FORM
SOLICITATION NO.:

Instructions: Please acknowledge receipt of all addenda issued with this solicitation by completing this addendum acknowledgment form. Check the box next to each addendum received and sign below. Failure to acknowledge addenda may result in bid disqualification.

Acknowledgment: I hereby acknowledge receipt of the following addenda and have made the necessary revisions to my proposal, plans and/or specification, etc.

Addendum Numbers Received:

(Check the box next to each addendum received)

- | | |
|--|--|
| <input checked="" type="checkbox"/> Addendum No. 1 | <input type="checkbox"/> Addendum No. 6 |
| <input type="checkbox"/> Addendum No. 2 | <input type="checkbox"/> Addendum No. 7 |
| <input type="checkbox"/> Addendum No. 3 | <input type="checkbox"/> Addendum No. 8 |
| <input type="checkbox"/> Addendum No. 4 | <input type="checkbox"/> Addendum No. 9 |
| <input type="checkbox"/> Addendum No. 5 | <input type="checkbox"/> Addendum No. 10 |

I understand that failure to confirm the receipt of addenda may be cause for rejection of this bid. I further understand that any verbal representation made or assumed to be made during any oral discussion held between Vendor's representatives and any state personnel is not binding. Only the information issued in writing and added to the specifications by an official addendum is binding.

WJ Electric Supply
Company

Tony Barber
Authorized Signature

4/3/19
Date

NOTE: This addendum acknowledgment should be submitted with the bid to expedite document processing.

STATE OF WEST VIRGINIA
Purchasing Division

PURCHASING AFFIDAVIT

CONSTRUCTION CONTRACTS: Under W. Va. Code § 5-22-1(i), the contracting public entity shall not award a construction contract to any bidder that is known to be in default on any monetary obligation owed to the state or a political subdivision of the state, including, but not limited to, obligations related to payroll taxes, property taxes, sales and use taxes, fire service fees, or other fines or fees.

ALL CONTRACTS: Under W. Va. Code §5A-3-10a, no contract or renewal of any contract may be awarded by the state or any of its political subdivisions to any vendor or prospective vendor when the vendor or prospective vendor or a related party to the vendor or prospective vendor is a debtor and: (1) the debt owed is an amount greater than one thousand dollars in the aggregate; or (2) the debtor is in employer default.

EXCEPTION: The prohibition listed above does not apply where a vendor has contested any tax administered pursuant to chapter eleven of the W. Va. Code, workers' compensation premium, permit fee or environmental fee or assessment and the matter has not become final or where the vendor has entered into a payment plan or agreement and the vendor is not in default of any of the provisions of such plan or agreement.

DEFINITIONS:

"Debt" means any assessment, premium, penalty, fine, tax or other amount of money owed to the state or any of its political subdivisions because of a judgment, fine, permit violation, license assessment, defaulted workers' compensation premium, penalty or other assessment presently delinquent or due and required to be paid to the state or any of its political subdivisions, including any interest or additional penalties accrued thereon.

"Employer default" means having an outstanding balance or liability to the old fund or to the uninsured employers' fund or being in policy default, as defined in W. Va. Code § 23-2c-2, failure to maintain mandatory workers' compensation coverage, or failure to fully meet its obligations as a workers' compensation self-insured employer. An employer is not in employer default if it has entered into a repayment agreement with the Insurance Commissioner and remains in compliance with the obligations under the repayment agreement.

"Related party" means a party, whether an individual, corporation, partnership, association, limited liability company or any other form or business association or other entity whatsoever, related to any vendor by blood, marriage, ownership or contract through which the party has a relationship of ownership or other interest with the vendor so that the party will actually or by effect receive or control a portion of the benefit, profit or other consideration from performance of a vendor contract with the party receiving an amount that meets or exceeds five percent of the total contract amount.

AFFIRMATION: By signing this form, the vendor's authorized signer affirms and acknowledges under penalty of law for false swearing (W. Va. Code §61-5-3) that: (1) for construction contracts, the vendor is not in default on any monetary obligation owed to the state or a political subdivision of the state, and (2) for all other contracts, that neither vendor nor any related party owe a debt as defined above and that neither vendor nor any related party are in employer default as defined above, unless the debt or employer default is permitted under the exception above.

WITNESS THE FOLLOWING SIGNATURE:

Vendor's Name: WV Electric Supply Co

Authorized Signature: Sharon A Maynard Date: 4/4/19

State of WV

County of Cabell, to-wit:

Taken, subscribed, and sworn to before me this 4th day of April, 2019.

My Commission expires June 15, 2023.

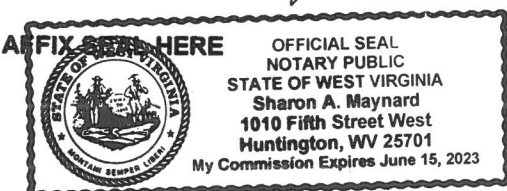

NOTARY PUBLIC Sharon A Maynard
Purchasing Affidavit (Revised 01/19/2018)