



Purchasing Division
 2019 Washington Street East
 Post Office Box 50130
 Charleston, WV 25305-0130

State of West Virginia
 Request for Quotation
 09 - Construction

Proc Folder: 414207

Doc Description: Addendum No. 2

Proc Type: Central Purchase Order

Date Issued	Solicitation Closes	Solicitation No	Version
2018-05-30	2018-06-13 13:30:00	CRFQ 0804 RMA1800000007	3

BID RECEIVING LOCATION

BID CLERK
 DEPARTMENT OF ADMINISTRATION
 PURCHASING DIVISION
 2019 WASHINGTON ST E
 CHARLESTON WV 25305
 US

VENDOR

Vendor Name, Address and Telephone Number:

RECEIVED

2018 JUN 13 AM 9:51

WV PURCHASING
 DIVISION

FOR INFORMATION CONTACT THE BUYER

Melissa Pettrey
 (304) 558-0094
 melissa.k.pettrey@wv.gov

Signature X *Auth M*

FEIN # 23-2938638

DATE 6/11/18

All offers subject to all terms and conditions contained in this solicitation

ADDITIONAL INFORMATION:

Addendum No. 2 is issued to publish and distribute the attached information to the vendor community.

Central Request for Quotation

The West Virginia Purchasing Division is soliciting bids on behalf of the West Virginia State Rail Authority (SRA) to establish a contract for the following: Repairs to bridges along the South Branch Valley Railroad (SBVR) The Vendor shall furnish any incidental work, materials, labor, and equipment that are necessary to complete the Construction Services per the terms and conditions and specifications as attached.

INVOICE TO		SHIP TO	
STATE RAIL AUTHORITY 120 WATER PLANT DR		STATE RAIL AUTHORITY (DBA) SOUTH BRANCH VALLEY RAILROAD 120 WATER PLANT DR	
MOOREFIELD	WV26836	MOOREFIELD	WV 26836
US		US	

Line	Comm Ln Desc	Qty	Unit Issue	Unit Price	Total Price
1	BR 8.5	0.00000 1.00	EA	\$ 4,900.00	\$ 4,900.00

Comm Code	Manufacturer	Specification	Model #
72141603			

Extended Description :

Replace post

INVOICE TO		SHIP TO	
STATE RAIL AUTHORITY 120 WATER PLANT DR		STATE RAIL AUTHORITY (DBA) SOUTH BRANCH VALLEY RAILROAD 120 WATER PLANT DR	
MOOREFIELD	WV26836	MOOREFIELD	WV 26836
US		US	

Line	Comm Ln Desc	Qty	Unit Issue	Unit Price	Total Price
2	BR 9.7	0.00000 1.00	EA	\$ 195,000.00	\$ 195,000.00

Comm Code	Manufacturer	Specification	Model #
72141603			

Extended Description :

Add a stringer to go from 3-ply to 4-ply on 39 spans

INVOICE TO		SHIP TO	
STATE RAIL AUTHORITY 120 WATER PLANT DR		STATE RAIL AUTHORITY (DBA) SOUTH BRANCH VALLEY RAILROAD 120 WATER PLANT DR	
MOOREFIELD	WW26836	MOOREFIELD	WW 26836
US		US	

Line	Comm Ln Desc	Qty	Unit Issue	Unit Price	Total Price
3	BR 15.2	0.00000 1.00	EA	\$ 9,300.00	\$ 9,300.00

Comm Code	Manufacturer	Specification	Model #
72141603			

Extended Description :
Replace piles

INVOICE TO		SHIP TO	
STATE RAIL AUTHORITY 120 WATER PLANT DR		STATE RAIL AUTHORITY (DBA) SOUTH BRANCH VALLEY RAILROAD 120 WATER PLANT DR	
MOOREFIELD	WW26836	MOOREFIELD	WW 26836
US		US	

Line	Comm Ln Desc	Qty	Unit Issue	Unit Price	Total Price
4	BR 17.1	0.00000 1.00	EA	\$ 5,700.00	\$ 5,700.00

Comm Code	Manufacturer	Specification	Model #
72141603			

Extended Description :
Replace bent, replace braces and add shims

INVOICE TO		SHIP TO	
STATE RAIL AUTHORITY 120 WATER PLANT DR		STATE RAIL AUTHORITY (DBA) SOUTH BRANCH VALLEY RAILROAD 120 WATER PLANT DR	
MOOREFIELD	WW26836	MOOREFIELD	WW 26836
US		US	

Line	Comm Ln Desc	Qty	Unit Issue	Unit Price	Total Price
5	BR 37.4	0.00000 1.00	EA	\$ 12,100.00	\$ 12,100.00

Comm Code	Manufacturer	Specification	Model #
72141603			

Extended Description :
Repair piles and install new cap

INVOICE TO		SHIP TO	
STATE RAIL AUTHORITY 120 WATER PLANT DR		STATE RAIL AUTHORITY (DBA) SOUTH BRANCH VALLEY RAILROAD 120 WATER PLANT DR	
MOOREFIELD	WV26836	MOOREFIELD	WV 26836
US		US	

Line	Comm Ln Desc	Qty	Unit Issue	Unit Price	Total Price
6	BR 43.8	0.00000 1.00	EA	\$58,000.00	\$58,000.00

Comm Code	Manufacturer	Specification	Model #
72141603			

Extended Description :
Replace bent, replace stringer and add stringers

INVOICE TO		SHIP TO	
STATE RAIL AUTHORITY 120 WATER PLANT DR		STATE RAIL AUTHORITY (DBA) SOUTH BRANCH VALLEY RAILROAD 120 WATER PLANT DR	
MOOREFIELD	WV26836	MOOREFIELD	WV 26836
US		US	

Line	Comm Ln Desc	Qty	Unit Issue	Unit Price	Total Price
7	BR 23.2	0.00000 1.00	EA	\$279,000.00	\$279,000.00

Comm Code	Manufacturer	Specification	Model #
72141603			

Extended Description :
BR 23.2 install gabion baskets for wing walls

TOTAL BID: \$564,000.00

RMA180000007	Document Phase Final	Document Description Addendum No. 2 Repair of 7 bridges on SBVR	Page 5 of 5
---------------------	--------------------------------	--	------------------------------

ADDITIONAL TERMS AND CONDITIONS

See attached document(s) for additional Terms and Conditions

INSTRUCTIONS TO VENDORS SUBMITTING BIDS

1. REVIEW DOCUMENTS THOROUGHLY: The attached documents contain a solicitation for bids. Please read these instructions and all documents attached in their entirety. These instructions provide critical information about requirements that if overlooked could lead to disqualification of a Vendor's bid. All bids must be submitted in accordance with the provisions contained in these instructions and the Solicitation. Failure to do so may result in disqualification of Vendor's bid.

2. MANDATORY TERMS: The Solicitation may contain mandatory provisions identified by the use of the words "must," "will," and "shall." Failure to comply with a mandatory term in the Solicitation will result in bid disqualification.

3. PREBID MEETING: The item identified below shall apply to this Solicitation.

A pre-bid meeting will not be held prior to bid opening

A NON-MANDATORY PRE-BID meeting will be held at the following place and time:

A MANDATORY PRE-BID meeting will be held at the following place and time:

State Rail Authority Office - Conference Room
120 Water Plant Drive
Moorefield, WV 26836

May 15, 2018 @ 10:30 a.m.

All Vendors submitting a bid must attend the mandatory pre-bid meeting. Failure to attend the mandatory pre-bid meeting shall result in disqualification of the Vendor's bid. No one person attending the pre-bid meeting may represent more than one Vendor.

An attendance sheet provided at the pre-bid meeting shall serve as the official document verifying attendance. The State will not accept any other form of proof or documentation to verify attendance. Any person attending the pre-bid meeting on behalf of a Vendor must list on the attendance sheet his or her name and the name of the Vendor he or she is representing.

Additionally, the person attending the pre-bid meeting should include the Vendor's E-Mail address, phone number, and Fax number on the attendance sheet. It is the Vendor's responsibility to locate the attendance sheet and provide the required information. Failure to complete the attendance sheet as required may result in disqualification of Vendor's bid.

All Vendors should arrive prior to the starting time for the pre-bid. Vendors who arrive after the starting time but prior to the end of the pre-bid will be permitted to sign in, but are charged with knowing all matters discussed at the pre-bid.

Questions submitted at least five business days prior to a scheduled pre-bid will be discussed at the pre-bid meeting if possible. Any discussions or answers to questions at the pre-bid meeting are preliminary in nature and are non-binding. Official and binding answers to questions will be published in a written addendum to the Solicitation prior to bid opening.

4. VENDOR QUESTION DEADLINE: Vendors may submit questions relating to this Solicitation to the Purchasing Division. Questions must be submitted in writing. All questions must be submitted on or before the date listed below and to the address listed below in order to be considered. A written response will be published in a Solicitation addendum if a response is possible and appropriate. Non-written discussions, conversations, or questions and answers regarding this Solicitation are preliminary in nature and are nonbinding.

Submitted e-mails should have solicitation number in the subject line.

Question Submission Deadline: 05/23/2018 @ 10:00 A.M. EDT

Submit Questions to: Melissa Pettrey, Senior Buyer
2019 Washington Street, East
Charleston, WV 25305
Fax: (304) 558-4115 (Vendors should not use this fax number for bid submission)
Email: Melissa.k.pettrey@wv.gov

5. VERBAL COMMUNICATION: Any verbal communication between the Vendor and any State personnel is not binding, including verbal communication at the mandatory pre-bid conference. Only information issued in writing and added to the Solicitation by an official written addendum by the Purchasing Division is binding.

6. BID SUBMISSION: All bids must be submitted electronically through wvOASIS or signed and delivered by the Vendor to the Purchasing Division at the address listed below on or before the date and time of the bid opening. Any bid received by the Purchasing Division staff is considered to be in the possession of the Purchasing Division and will not be returned for any reason. The Purchasing Division will not accept bids, modification of bids, or addendum acknowledgment forms via e-mail. Acceptable delivery methods include electronic submission via wvOASIS, hand delivery, delivery by courier, or facsimile.

The bid delivery address is:
Department of Administration, Purchasing Division
2019 Washington Street East
Charleston, WV 25305-0130

A bid that is not submitted electronically through wvOASIS should contain the information listed below on the face of the envelope or the bid may be rejected by the Purchasing Division.:

SEALED BID:

BUYER: Melissa Pettrey, Senior Buyer

SOLICITATION NO.:

BID OPENING DATE:

BID OPENING TIME:

FAX NUMBER:

The Purchasing Division may prohibit the submission of bids electronically through wvOASIS at its sole discretion. Such a prohibition will be contained and communicated in the wvOASIS system resulting in the Vendor's inability to submit bids through wvOASIS. Submission of a response to an Expression or Interest or Request for Proposal is not permitted in wvOASIS.

For Request For Proposal ("RFP") Responses Only: In the event that Vendor is responding to a request for proposal, the Vendor shall submit one original technical and one original cost proposal plus _____ convenience copies of each to the Purchasing Division at the address shown above. Additionally, the Vendor should identify the bid type as either a technical or cost proposal on the face of each bid envelope submitted in response to a request for proposal as follows:

BID TYPE: (This only applies to CRFP)

Technical

Cost

7. BID OPENING: Bids submitted in response to this Solicitation will be opened at the location identified below on the date and time listed below. Delivery of a bid after the bid opening date and time will result in bid disqualification. For purposes of this Solicitation, a bid is considered delivered when confirmation of delivery is provided by wvOASIS (in the case of electronic submission) or when the bid is time stamped by the official Purchasing Division time clock (in the case of hand delivery).

Bid Opening Date and Time: 06/05/2018 @ 1:30 P.M. EDT

Bid Opening Location: Department of Administration, Purchasing Division
2019 Washington Street East
Charleston, WV 25305-0130

8. ADDENDUM ACKNOWLEDGEMENT: Changes or revisions to this Solicitation will be made by an official written addendum issued by the Purchasing Division. Vendor should acknowledge receipt of all addenda issued with this Solicitation by completing an Addendum Acknowledgment Form, a copy of which is included herewith. Failure to acknowledge addenda may result in bid disqualification. The addendum acknowledgement should be submitted with the bid to expedite document processing.

9. BID FORMATTING: Vendor should type or electronically enter the information onto its bid to prevent errors in the evaluation. Failure to type or electronically enter the information may result in bid disqualification.

10. ALTERNATES: Any model, brand, or specification listed in this Solicitation establishes the acceptable level of quality only and is not intended to reflect a preference for, or in any way favor, a particular brand or vendor. Vendors may bid alternates to a listed model or brand provided that the alternate is at least equal to the model or brand and complies with the required specifications. The equality of any alternate being bid shall be determined by the State at its sole discretion. Any Vendor bidding an alternate model or brand should clearly identify the alternate items in its bid and should include manufacturer's specifications, industry literature, and/or any other relevant documentation demonstrating the equality of the alternate items. Failure to provide information for alternate items may be grounds for rejection of a Vendor's bid.

11. EXCEPTIONS AND CLARIFICATIONS: The Solicitation contains the specifications that shall form the basis of a contractual agreement. Vendor shall clearly mark any exceptions, clarifications, or other proposed modifications in its bid. Exceptions to, clarifications of, or modifications of a requirement or term and condition of the Solicitation may result in bid disqualification.

12. COMMUNICATION LIMITATIONS: In accordance with West Virginia Code of State Rules §148-1-6.6, communication with the State of West Virginia or any of its employees regarding this Solicitation during the solicitation, bid, evaluation or award periods, except through the Purchasing Division, is strictly prohibited without prior Purchasing Division approval. Purchasing Division approval for such communication is implied for all agency delegated and exempt purchases.

13. REGISTRATION: Prior to Contract award, the apparent successful Vendor must be properly registered with the West Virginia Purchasing Division and must have paid the \$125 fee, if applicable.

14. UNIT PRICE: Unit prices shall prevail in cases of a discrepancy in the Vendor's bid.

15. PREFERENCE: Vendor Preference may only be granted upon written request and only in accordance with the West Virginia Code § 5A-3-37 and the West Virginia Code of State Rules. A Vendor Preference Certificate form has been attached hereto to allow Vendor to apply for the preference. Vendor's failure to submit the Vendor Preference Certificate form with its bid will result in denial of Vendor Preference. Vendor Preference does not apply to construction projects.

16. SMALL, WOMEN-OWNED, OR MINORITY-OWNED BUSINESSES: For any solicitations publicly advertised for bid, in accordance with West Virginia Code §5A-3-37(a)(7) and W. Va. CSR § 148-22-9, any non-resident vendor certified as a small, women-owned, or minority-owned business under W. Va. CSR § 148-22-9 shall be provided the same preference made available to any resident vendor. Any non-resident small, women-owned, or minority-owned business must identify itself as such in writing, must submit that writing to the Purchasing Division with its bid, and must be properly certified under W. Va. CSR § 148-22-9 prior to contract award to receive the preferences made available to resident vendors. Preference for a non-resident small, women-owned, or minority owned business shall be applied in accordance with W. Va. CSR § 148-22-9.

17. WAIVER OF MINOR IRREGULARITIES: The Director reserves the right to waive minor irregularities in bids or specifications in accordance with West Virginia Code of State Rules § 148-1-4.6.

18. ELECTRONIC FILE ACCESS RESTRICTIONS: Vendor must ensure that its submission in wvOASIS can be accessed and viewed by the Purchasing Division staff immediately upon bid opening. The Purchasing Division will consider any file that cannot be immediately accessed and viewed at the time of the bid opening (such as, encrypted files, password protected files, or incompatible files) to be blank or incomplete as context requires, and are therefore unacceptable. A vendor will not be permitted to unencrypt files, remove password protections, or resubmit documents after bid opening to make a file viewable if those documents are required with the bid. A Vendor may be required to provide document passwords or remove access restrictions to allow the Purchasing Division to print or electronically save documents provided that those documents are viewable by the Purchasing Division prior to obtaining the password or removing the access restriction.

19. NON-RESPONSIBLE: The Purchasing Division Director reserves the right to reject the bid of any vendor as Non-Responsible in accordance with W. Va. Code of State Rules § 148-1-5.3, when the Director determines that the vendor submitting the bid does not have the capability to fully perform, or lacks the integrity and reliability to assure good-faith performance.”

20. ACCEPTANCE/REJECTION: The State may accept or reject any bid in whole, or in part in accordance with W. Va. Code of State Rules § 148-1-4.5. and § 148-1-6.4.b.”

21. YOUR SUBMISSION IS A PUBLIC DOCUMENT: Vendor’s entire response to the Solicitation and the resulting Contract are public documents. As public documents, they will be disclosed to the public following the bid/proposal opening or award of the contract, as required by the competitive bidding laws of West Virginia Code §§ 5A-3-1 et seq., 5-22-1 et seq., and 5G-1-1 et seq. and the Freedom of Information Act West Virginia Code §§ 29B-1-1 et seq.

DO NOT SUBMIT MATERIAL YOU CONSIDER TO BE CONFIDENTIAL, A TRADE SECRET, OR OTHERWISE NOT SUBJECT TO PUBLIC DISCLOSURE.

Submission of any bid, proposal, or other document to the Purchasing Division constitutes your explicit consent to the subsequent public disclosure of the bid, proposal, or document. The Purchasing Division will disclose any document labeled "confidential," "proprietary," "trade secret," "private," or labeled with any other claim against public disclosure of the documents, to include any "trade secrets" as defined by West Virginia Code § 47-22-1 et seq. All submissions are subject to public disclosure without notice.

22. INTERESTED PARTY DISCLOSURE: W. Va. Code § 6D-1-2 requires that for contracts with an actual or estimated value of at least \$100,000, the vendor must submit to the Purchasing Division a disclosure of interested parties to the contract, prior to contract award. That disclosure must occur on the form prescribed and approved by the WV Ethics Commission. A copy of that form is included with this solicitation or can be obtained from the WV Ethics Commission.

"Interested parties" means: (1) A business entity performing work or service pursuant to, or in furtherance of, the applicable contract, including specifically sub-contractors; (2) the person(s) who have an ownership interest equal to or greater than 25% in the business entity performing work or service pursuant to, or in furtherance of, the applicable contract; and (3) the person or business entity, if any, that served as a compensated broker or intermediary to actively facilitate the applicable contract or negotiated the terms of the applicable contract with the state agency: Provided, That subdivision (2) shall be inapplicable if a business entity is a publicly traded company: Provided, however, That subdivision (3) shall not include persons or business entities performing legal services related to the negotiation or drafting of the applicable contract.

23. WITH THE BID REQUIREMENTS: In instances where these specifications require documentation or other information with the bid, and a vendor fails to provide it with the bid, the Director of the Purchasing Division reserves the right to request those items after bid opening and prior to contract award pursuant to the authority to waive minor irregularities in bids or specifications under W. Va. CSR § 148-1-4.6. This authority does not apply to instances where state law mandates receipt with the bid.

GENERAL TERMS AND CONDITIONS:

1. CONTRACTUAL AGREEMENT: Issuance of a Award Document signed by the Purchasing Division Director, or his designee, and approved as to form by the Attorney General's office constitutes acceptance of this Contract made by and between the State of West Virginia and the Vendor. Vendor's signature on its bid signifies Vendor's agreement to be bound by and accept the terms and conditions contained in this Contract.

2. DEFINITIONS: As used in this Solicitation/Contract, the following terms shall have the meanings attributed to them below. Additional definitions may be found in the specifications included with this Solicitation/Contract.

2.1. "Agency" or "Agencies" means the agency, board, commission, or other entity of the State of West Virginia that is identified on the first page of the Solicitation or any other public entity seeking to procure goods or services under this Contract.

2.2. "Bid" or "Proposal" means the vendors submitted response to this solicitation.

2.3. "Contract" means the binding agreement that is entered into between the State and the Vendor to provide the goods or services requested in the Solicitation.

2.4. "Director" means the Director of the West Virginia Department of Administration, Purchasing Division.

2.5. "Purchasing Division" means the West Virginia Department of Administration, Purchasing Division.

2.6. "Award Document" means the document signed by the Agency and the Purchasing Division, and approved as to form by the Attorney General, that identifies the Vendor as the contract holder.

2.7. "Solicitation" means the official notice of an opportunity to supply the State with goods or services that is published by the Purchasing Division.

2.8. "State" means the State of West Virginia and/or any of its agencies, commissions, boards, etc. as context requires.

2.9. "Vendor" or "Vendors" means any entity submitting a bid in response to the Solicitation, the entity that has been selected as the lowest responsible bidder, or the entity that has been awarded the Contract as context requires.

3. CONTRACT TERM; RENEWAL; EXTENSION: The term of this Contract shall be determined in accordance with the category that has been identified as applicable to this Contract below:

Term Contract

Initial Contract Term: **Initial Contract Term:** This Contract becomes effective on _____ and extends for a period of _____ year(s).

Renewal Term: This Contract may be renewed upon the mutual written consent of the Agency, and the Vendor, with approval of the Purchasing Division and the Attorney General's office (Attorney General approval is as to form only). Any request for renewal should be delivered to the Agency and then submitted to the Purchasing Division thirty (30) days prior to the expiration date of the initial contract term or appropriate renewal term. A Contract renewal shall be in accordance with the terms and conditions of the original contract. Unless otherwise specified below, renewal of this Contract is limited to _____ successive one (1) year periods or multiple renewal periods of less than one year, provided that the multiple renewal periods do not exceed the total number of months available in all renewal years combined. Automatic renewal of this Contract is prohibited. Renewals must be approved by the Vendor, Agency, Purchasing Division and Attorney General's office (Attorney General approval is as to form only)

Alternate Renewal Term – This contract may be renewed for _____ successive _____ year periods or shorter periods provided that they do not exceed the total number of months contained in all available renewals. Automatic renewal of this Contract is prohibited. Renewals must be approved by the Vendor, Agency, Purchasing Division and Attorney General's office (Attorney General approval is as to form only)

Delivery Order Limitations: In the event that this contract permits delivery orders, a delivery order may only be issued during the time this Contract is in effect. Any delivery order issued within one year of the expiration of this Contract shall be effective for one year from the date the delivery order is issued. No delivery order may be extended beyond one year after this Contract has expired.

Fixed Period Contract: This Contract becomes effective upon Vendor's receipt of the notice to proceed and must be completed within three hundred and sixty-five (365) calendar days.

Fixed Period Contract with Renewals: This Contract becomes effective upon Vendor's receipt of the notice to proceed and part of the Contract more fully described in the attached specifications must be completed within _____ days. Upon completion of the work covered by the preceding sentence, the vendor agrees that maintenance, monitoring, or warranty services will be provided for _____ year(s) thereafter.

One Time Purchase: The term of this Contract shall run from the issuance of the Award Document until all of the goods contracted for have been delivered, but in no event will this Contract extend for more than one fiscal year.

Other: See attached.

4. NOTICE TO PROCEED: Vendor shall begin performance of this Contract immediately upon receiving notice to proceed unless otherwise instructed by the Agency. Unless otherwise specified, the fully executed Award Document will be considered notice to proceed.

5. QUANTITIES: The quantities required under this Contract shall be determined in accordance with the category that has been identified as applicable to this Contract below.

Open End Contract: Quantities listed in this Solicitation are approximations only, based on estimates supplied by the Agency. It is understood and agreed that the Contract shall cover the quantities actually ordered for delivery during the term of the Contract, whether more or less than the quantities shown.

Service: The scope of the service to be provided will be more clearly defined in the specifications included herewith.

Combined Service and Goods: The scope of the service and deliverable goods to be provided will be more clearly defined in the specifications included herewith.

One Time Purchase: This Contract is for the purchase of a set quantity of goods that are identified in the specifications included herewith. Once those items have been delivered, no additional goods may be procured under this Contract without an appropriate change order approved by the Vendor, Agency, Purchasing Division, and Attorney General's office.

6. EMERGENCY PURCHASES: The Purchasing Division Director may authorize the Agency to purchase goods or services in the open market that Vendor would otherwise provide under this Contract if those goods or services are for immediate or expedited delivery in an emergency. Emergencies shall include, but are not limited to, delays in transportation or an unanticipated increase in the volume of work. An emergency purchase in the open market, approved by the Purchasing Division Director, shall not constitute a breach of this Contract and shall not entitle the Vendor to any form of compensation or damages. This provision does not excuse the State from fulfilling its obligations under a One Time Purchase contract.

7. REQUIRED DOCUMENTS: All of the items checked below must be provided to the Purchasing Division by the Vendor as specified below.

BID BOND (Construction Only): Pursuant to the requirements contained in W. Va. Code § 5-22-1(c), All Vendors submitting a bid on a construction project shall furnish a valid bid bond in the amount of five percent (5%) of the total amount of the bid protecting the State of West Virginia. The bid bond must be submitted with the bid.

PERFORMANCE BOND: The apparent successful Vendor shall provide a performance bond in the amount of 100% of Contract Award. The performance bond must be received by the Purchasing Division prior to Contract award. On construction contracts, the performance bond must be 100% of the Contract value.

LABOR/MATERIAL PAYMENT BOND: The apparent successful Vendor shall provide a labor/material payment bond in the amount of 100% of the Contract value. The labor/material payment bond must be delivered to the Purchasing Division prior to Contract award.

In lieu of the Bid Bond, Performance Bond, and Labor/Material Payment Bond, the Vendor may provide certified checks, cashier's checks, or irrevocable letters of credit. Any certified check, cashier's check, or irrevocable letter of credit provided in lieu of a bond must be of the same amount and delivered on the same schedule as the bond it replaces. A letter of credit submitted in lieu of a performance and labor/material payment bond will only be allowed for projects under \$100,000. Personal or business checks are not acceptable. Notwithstanding the foregoing, West Virginia Code § 5-22-1 (d) mandates that a vendor provide a performance and labor/material payment bond for construction projects. Accordingly, substitutions for the performance and labor/material payment bonds for construction projects is not permitted.

MAINTENANCE BOND: The apparent successful Vendor shall provide a two (2) year maintenance bond covering the roofing system. The maintenance bond must be issued and delivered to the Purchasing Division prior to Contract award.

LICENSE(S) / CERTIFICATIONS / PERMITS: In addition to anything required under the Section entitled Licensing, of the General Terms and Conditions, the apparent successful Vendor shall furnish proof of the following licenses, certifications, and/or permits prior to Contract award, in a form acceptable to the Purchasing Division.

The apparent successful Vendor shall also furnish proof of any additional licenses or certifications contained in the specifications prior to Contract award regardless of whether or not that requirement is listed above.

8. INSURANCE: The apparent successful Vendor shall furnish proof of the insurance identified by a checkmark below prior to Contract award. Subsequent to contract award, and prior to the insurance expiration date, Vendor shall provide the Agency with proof that the insurance mandated herein has been continued. Vendor must also provide Agency with immediate notice of any changes in its insurance policies mandated herein, including but not limited to, policy cancelation, policy reduction, or change in insurers. The insurance coverages identified below must be maintained throughout the life of this contract. The apparent successful Vendor shall also furnish proof of any additional insurance requirements contained in the specifications prior to Contract award regardless of whether or not that insurance requirement is listed in this section.

Vendor must maintain:

Commercial General Liability Insurance in at least an amount of:
\$1,000,000.00 or more

Automobile Liability Insurance in at least an amount of: \$1,000,000.00 or more

Professional/Malpractice/Errors and Omission Insurance in at least an amount of:

Commercial Crime and Third Party Fidelity Insurance in an amount of:

Cyber Liability Insurance in an amount of: _____

Builders Risk Insurance in an amount equal to 100% of the amount of the Contract.

9. WORKERS' COMPENSATION INSURANCE: The apparent successful Vendor shall comply with laws relating to workers compensation, shall maintain workers' compensation insurance when required, and shall furnish proof of workers' compensation insurance upon request.

10. [Reserved]

11. LIQUIDATED DAMAGES: This clause shall in no way be considered exclusive and shall not limit the State or Agency's right to pursue any other available remedy. Vendor shall pay liquidated damages in the amount specified below or as described in the specifications:

one thousand (\$1000.00) for every calendar day beyond three-hundred sixty-five (365) days

Liquidated Damages Contained in the Specifications

12. ACCEPTANCE: Vendor's signature on its bid, or on the certification and signature page, constitutes an offer to the State that cannot be unilaterally withdrawn, signifies that the product or service proposed by vendor meets the mandatory requirements contained in the Solicitation for that product or service, unless otherwise indicated, and signifies acceptance of the terms and conditions contained in the Solicitation unless otherwise indicated.

13. PRICING: The pricing set forth herein is firm for the life of the Contract, unless specified elsewhere within this Solicitation/Contract by the State. A Vendor's inclusion of price adjustment provisions in its bid, without an express authorization from the State in the Solicitation to do so, may result in bid disqualification.

14. PAYMENT: Payment in advance is prohibited under this Contract. Payment may only be made after the delivery and acceptance of goods or services. The Vendor shall submit invoices, in arrears.

15. PURCHASING CARD ACCEPTANCE: The State of West Virginia currently utilizes a Purchasing Card program, administered under contract by a banking institution, to process payment for goods and services. The Vendor must accept the State of West Virginia's Purchasing Card for payment of all orders under this Contract unless the box below is checked.

Vendor is not required to accept the State of West Virginia's Purchasing Card as payment for all goods and services.

16. TAXES: The Vendor shall pay any applicable sales, use, personal property or any other taxes arising out of this Contract and the transactions contemplated thereby. The State of West Virginia is exempt from federal and state taxes and will not pay or reimburse such taxes.

17. ADDITIONAL FEES: Vendor is not permitted to charge additional fees or assess additional charges that were not either expressly provided for in the solicitation published by the State of West Virginia or included in the unit price or lump sum bid amount that Vendor is required by the solicitation to provide. Including such fees or charges as notes to the solicitation may result in rejection of vendor's bid. Requesting such fees or charges be paid after the contract has been awarded may result in cancellation of the contract.

18. FUNDING: This Contract shall continue for the term stated herein, contingent upon funds being appropriated by the Legislature or otherwise being made available. In the event funds are not appropriated or otherwise made available, this Contract becomes void and of no effect beginning on July 1 of the fiscal year for which funding has not been appropriated or otherwise made available.

19. CANCELLATION: The Purchasing Division Director reserves the right to cancel this Contract immediately upon written notice to the vendor if the materials or workmanship supplied do not conform to the specifications contained in the Contract. The Purchasing Division Director may also cancel any purchase or Contract upon 30 days written notice to the Vendor in accordance with West Virginia Code of State Rules § 148-1-5.2.b.

20. TIME: Time is of the essence with regard to all matters of time and performance in this Contract.

21. APPLICABLE LAW: This Contract is governed by and interpreted under West Virginia law without giving effect to its choice of law principles. Any information provided in specification manuals, or any other source, verbal or written, which contradicts or violates the West Virginia Constitution, West Virginia Code or West Virginia Code of State Rules is void and of no effect.

22. COMPLIANCE WITH LAWS: Vendor shall comply with all applicable federal, state, and local laws, regulations and ordinances. By submitting a bid, Vendor acknowledges that it has reviewed, understands, and will comply with all applicable laws, regulations, and ordinances.

SUBCONTRACTOR COMPLIANCE: Vendor shall notify all subcontractors providing commodities or services related to this Contract that as subcontractors, they too are required to comply with all applicable laws, regulations, and ordinances. Notification under this provision must occur prior to the performance of any work under the contract by the subcontractor.

23. ARBITRATION: Any references made to arbitration contained in this Contract, Vendor's bid, or in any American Institute of Architects documents pertaining to this Contract are hereby deleted, void, and of no effect.

24. MODIFICATIONS: This writing is the parties' final expression of intent. Notwithstanding anything contained in this Contract to the contrary no modification of this Contract shall be binding without mutual written consent of the Agency, and the Vendor, with approval of the Purchasing Division and the Attorney General's office (Attorney General approval is as to form only). Any change to existing contracts that adds work or changes contract cost, and were not included in the original contract, must be approved by the Purchasing Division and the Attorney General's Office (as to form) prior to the implementation of the change or commencement of work affected by the change.

25. WAIVER: The failure of either party to insist upon a strict performance of any of the terms or provision of this Contract, or to exercise any option, right, or remedy herein contained, shall not be construed as a waiver or a relinquishment for the future of such term, provision, option, right, or remedy, but the same shall continue in full force and effect. Any waiver must be expressly stated in writing and signed by the waiving party.

26. SUBSEQUENT FORMS: The terms and conditions contained in this Contract shall supersede any and all subsequent terms and conditions which may appear on any form documents submitted by Vendor to the Agency or Purchasing Division such as price lists, order forms, invoices, sales agreements, or maintenance agreements, and includes internet websites or other electronic documents. Acceptance or use of Vendor's forms does not constitute acceptance of the terms and conditions contained thereon.

27. ASSIGNMENT: Neither this Contract nor any monies due, or to become due hereunder, may be assigned by the Vendor without the express written consent of the Agency, the Purchasing Division, the Attorney General's office (as to form only), and any other government agency or office that may be required to approve such assignments. Notwithstanding the foregoing, Purchasing Division approval may or may not be required on certain agency delegated or exempt purchases.

28. WARRANTY: The Vendor expressly warrants that the goods and/or services covered by this Contract will: (a) conform to the specifications, drawings, samples, or other description furnished or specified by the Agency; (b) be merchantable and fit for the purpose intended; and (c) be free from defect in material and workmanship.

29. STATE EMPLOYEES: State employees are not permitted to utilize this Contract for personal use and the Vendor is prohibited from permitting or facilitating the same.

30. BANKRUPTCY: In the event the Vendor files for bankruptcy protection, the State of West Virginia may deem this Contract null and void, and terminate this Contract without notice.

31. PRIVACY, SECURITY, AND CONFIDENTIALITY: The Vendor agrees that it will not disclose to anyone, directly or indirectly, any such personally identifiable information or other confidential information gained from the Agency, unless the individual who is the subject of the information consents to the disclosure in writing or the disclosure is made pursuant to the Agency's policies, procedures, and rules. Vendor further agrees to comply with the Confidentiality Policies and Information Security Accountability Requirements, set forth in <http://www.state.wv.us/admin/purchase/privacy/default.html>.

32. YOUR SUBMISSION IS A PUBLIC DOCUMENT: Vendor's entire response to the Solicitation and the resulting Contract are public documents. As public documents, they will be disclosed to the public following the bid/proposal opening or award of the contract, as required by the competitive bidding laws of West Virginia Code §§ 5A-3-1 et seq., 5-22-1 et seq., and 5G-1-1 et seq. and the Freedom of Information Act West Virginia Code §§ 29B-1-1 et seq.

DO NOT SUBMIT MATERIAL YOU CONSIDER TO BE CONFIDENTIAL, A TRADE SECRET, OR OTHERWISE NOT SUBJECT TO PUBLIC DISCLOSURE.

Submission of any bid, proposal, or other document to the Purchasing Division constitutes your explicit consent to the subsequent public disclosure of the bid, proposal, or document. The Purchasing Division will disclose any document labeled "confidential," "proprietary," "trade secret," "private," or labeled with any other claim against public disclosure of the documents, to include any "trade secrets" as defined by West Virginia Code § 47-22-1 et seq. All submissions are subject to public disclosure without notice.

33. LICENSING: In accordance with West Virginia Code of State Rules § 148-1-6.1.e, Vendor must be licensed and in good standing in accordance with any and all state and local laws and requirements by any state or local agency of West Virginia, including, but not limited to, the West Virginia Secretary of State's Office, the West Virginia Tax Department, West Virginia Insurance Commission, or any other state agency or political subdivision. Obligations related to political subdivisions may include, but are not limited to, business licensing, business and occupation taxes, inspection compliance, permitting, etc. Upon request, the Vendor must provide all necessary releases to obtain information to enable the Purchasing Division Director or the Agency to verify that the Vendor is licensed and in good standing with the above entities.

SUBCONTRACTOR COMPLIANCE: Vendor shall notify all subcontractors providing commodities or services related to this Contract that as subcontractors, they too are required to be licensed, in good standing, and up-to-date on all state and local obligations as described in this section. Obligations related to political subdivisions may include, but are not limited to, business licensing, business and occupation taxes, inspection compliance, permitting, etc. Notification under this provision must occur prior to the performance of any work under the contract by the subcontractor.

34. ANTITRUST: In submitting a bid to, signing a contract with, or accepting a Award Document from any agency of the State of West Virginia, the Vendor agrees to convey, sell, assign, or transfer to the State of West Virginia all rights, title, and interest in and to all causes of action it may now or hereafter acquire under the antitrust laws of the United States and the State of West Virginia for price fixing and/or unreasonable restraints of trade relating to the particular commodities or services purchased or acquired by the State of West Virginia. Such assignment shall be made and become effective at the time the purchasing agency tenders the initial payment to Vendor.

35. VENDOR CERTIFICATIONS: By signing its bid or entering into this Contract, Vendor certifies (1) that its bid or offer was made without prior understanding, agreement, or connection with any corporation, firm, limited liability company, partnership, person or entity submitting a bid or offer for the same material, supplies, equipment or services; (2) that its bid or offer is in all respects fair and without collusion or fraud; (3) that this Contract is accepted or entered into without any prior understanding, agreement, or connection to any other entity that could be considered a violation of law; and (4) that it has reviewed this Solicitation in its entirety; understands the requirements, terms and conditions, and other information contained herein.

Vendor's signature on its bid or offer also affirms that neither it nor its representatives have any interest, nor shall acquire any interest, direct or indirect, which would compromise the performance of its services hereunder. Any such interests shall be promptly presented in detail to the Agency. The individual signing this bid or offer on behalf of Vendor certifies that he or she is authorized by the Vendor to execute this bid or offer or any documents related thereto on Vendor's behalf; that he or she is authorized to bind the Vendor in a contractual relationship; and that, to the best of his or her knowledge, the Vendor has properly registered with any State agency that may require registration.

36. VENDOR RELATIONSHIP: The relationship of the Vendor to the State shall be that of an independent contractor and no principal-agent relationship or employer-employee relationship is contemplated or created by this Contract. The Vendor as an independent contractor is solely liable for the acts and omissions of its employees and agents. Vendor shall be responsible for selecting, supervising, and compensating any and all individuals employed pursuant to the terms of this Solicitation and resulting contract. Neither the Vendor, nor any employees or subcontractors of the Vendor, shall be deemed to be employees of the State for any purpose whatsoever. Vendor shall be exclusively responsible for payment of employees and contractors for all wages and salaries, taxes, withholding payments, penalties, fees, fringe benefits, professional liability insurance premiums, contributions to insurance and pension, or other deferred compensation plans, including but not limited to, Workers' Compensation and Social Security obligations, licensing fees, etc. and the filing of all necessary documents, forms, and returns pertinent to all of the foregoing.

Vendor shall hold harmless the State, and shall provide the State and Agency with a defense against any and all claims including, but not limited to, the foregoing payments, withholdings, contributions, taxes, Social Security taxes, and employer income tax returns.

37. INDEMNIFICATION: The Vendor agrees to indemnify, defend, and hold harmless the State and the Agency, their officers, and employees from and against: (1) Any claims or losses for services rendered by any subcontractor, person, or firm performing or supplying services, materials, or supplies in connection with the performance of the Contract; (2) Any claims or losses resulting to any person or entity injured or damaged by the Vendor, its officers, employees, or subcontractors by the publication, translation, reproduction, delivery, performance, use, or disposition of any data used under the Contract in a manner not authorized by the Contract, or by Federal or State statutes or regulations; and (3) Any failure of the Vendor, its officers, employees, or subcontractors to observe State and Federal laws including, but not limited to, labor and wage and hour laws.

38. PURCHASING AFFIDAVIT: In accordance with West Virginia Code § 5-22-1(i), the contracting public entity shall not award a contract for a construction project to any bidder that is known to be in default on any monetary obligation owed to the state or a political subdivision of the state, including, but not limited to, obligations related to payroll taxes, property taxes, sales and use taxes, fire service fees, or other fines or fees. Accordingly, prior to contract award, Vendors are required to sign, notarize, and submit the Purchasing Affidavit to the Purchasing Division affirming under oath that it is not in default on any monetary obligation owed to the state or a political subdivision of the state.

39. ADDITIONAL AGENCY AND LOCAL GOVERNMENT USE: This Contract may be utilized by other agencies, spending units, and political subdivisions of the State of West Virginia; county, municipal, and other local government bodies; and school districts ("Other Government Entities"). Any extension of this Contract to the aforementioned Other Government Entities must be on the same prices, terms, and conditions as those offered and agreed to in this Contract, provided that such extension is in compliance with the applicable laws, rules, and ordinances of the Other Government Entity. If the Vendor does not wish to extend the prices, terms, and conditions of its bid and subsequent contract to the Other Government Entities, the Vendor must clearly indicate such refusal in its bid. A refusal to extend this Contract to the Other Government Entities shall not impact or influence the award of this Contract in any manner.

40. CONFLICT OF INTEREST: Vendor, its officers or members or employees, shall not presently have or acquire an interest, direct or indirect, which would conflict with or compromise the performance of its obligations hereunder. Vendor shall periodically inquire of its officers, members and employees to ensure that a conflict of interest does not arise. Any conflict of interest discovered shall be promptly presented in detail to the Agency.

41. REPORTS: Vendor shall provide the Agency and/or the Purchasing Division with the following reports identified by a checked box below:

Such reports as the Agency and/or the Purchasing Division may request. Requested reports may include, but are not limited to, quantities purchased, agencies utilizing the contract, total contract expenditures by agency, etc.

Quarterly reports detailing the total quantity of purchases in units and dollars, along with a listing of purchases by agency. Quarterly reports should be delivered to the Purchasing Division via email at purchasing.requisitions@wv.gov.

42. BACKGROUND CHECK: In accordance with W. Va. Code § 15-2D-3, the Director of the Division of Protective Services shall require any service provider whose employees are regularly employed on the grounds or in the buildings of the Capitol complex or who have access to sensitive or critical information to submit to a fingerprint-based state and federal background inquiry through the state repository. The service provider is responsible for any costs associated with the fingerprint-based state and federal background inquiry.

After the contract for such services has been approved, but before any such employees are permitted to be on the grounds or in the buildings of the Capitol complex or have access to sensitive or critical information, the service provider shall submit a list of all persons who will be physically present and working at the Capitol complex to the Director of the Division of

Protective Services for purposes of verifying compliance with this provision. The State reserves the right to prohibit a service provider's employees from accessing sensitive or critical information or to be present at the Capitol complex based upon results addressed from a criminal background check.

Service providers should contact the West Virginia Division of Protective Services by phone at (304) 558-9911 for more information.

43. PREFERENCE FOR USE OF DOMESTIC STEEL PRODUCTS: Except when authorized by the Director of the Purchasing Division pursuant to W. Va. Code § 5A-3-56, no contractor may use or supply steel products for a State Contract Project other than those steel products made in the United States. A contractor who uses steel products in violation of this section may be subject to civil penalties pursuant to W. Va. Code § 5A-3-56. As used in this section:

- a. "State Contract Project" means any erection or construction of, or any addition to, alteration of or other improvement to any building or structure, including, but not limited to, roads or highways, or the installation of any heating or cooling or ventilating plants or other equipment, or the supply of and materials for such projects, pursuant to a contract with the State of West Virginia for which bids were solicited on or after June 6, 2001.
- b. "Steel Products" means products rolled, formed, shaped, drawn, extruded, forged, cast, fabricated or otherwise similarly processed, or processed by a combination of two or more or such operations, from steel made by the open heath, basic oxygen, electric furnace, Bessemer or other steel making process. The Purchasing Division Director may, in writing, authorize the use of foreign steel products if:
- c. The cost for each contract item used does not exceed one tenth of one percent (.1%) of the total contract cost or two thousand five hundred dollars (\$2,500.00), whichever is greater. For the purposes of this section, the cost is the value of the steel product as delivered to the project; or
- d. The Director of the Purchasing Division determines that specified steel materials are not produced in the United States in sufficient quantity or otherwise are not reasonably available to meet contract requirements.

44. PREFERENCE FOR USE OF DOMESTIC ALUMINUM, GLASS, AND STEEL: In Accordance with W. Va. Code § 5-19-1 et seq., and W. Va. CSR § 148-10-1 et seq., for every contract or subcontract, subject to the limitations contained herein, for the construction, reconstruction, alteration, repair, improvement or maintenance of public works or for the purchase of any item of machinery or equipment to be used at sites of public works, only domestic aluminum, glass or steel products shall be supplied unless the spending officer determines, in writing, after the receipt of offers or bids, (1) that the cost of domestic aluminum, glass or steel products is unreasonable or inconsistent with the public interest of the State of West Virginia, (2) that domestic aluminum, glass or steel products are not produced in sufficient quantities to meet the contract requirements, or (3) the available domestic aluminum, glass, or steel do not meet the contract specifications. This provision only applies to public works contracts awarded in an amount more than fifty thousand dollars (\$50,000) or public works contracts that require more than ten thousand pounds of steel products.

The cost of domestic aluminum, glass, or steel products may be unreasonable if the cost is more than twenty percent (20%) of the bid or offered price for foreign made aluminum, glass, or steel products. If the domestic aluminum, glass or steel products to be supplied or produced in a "substantial labor surplus area", as defined by the United States Department of Labor, the cost of domestic aluminum, glass, or steel products may be unreasonable if the cost is more than thirty percent (30%) of the bid or offered price for foreign made aluminum, glass, or steel products. This preference shall be applied to an item of machinery or equipment, as indicated above, when the item is a single unit of equipment or machinery manufactured primarily of aluminum, glass or steel, is part of a public works contract and has the sole purpose or of being a permanent part of a single public works project. This provision does not apply to equipment or machinery purchased by a spending unit for use by that spending unit and not as part of a single public works project.

All bids and offers including domestic aluminum, glass or steel products that exceed bid or offer prices including foreign aluminum, glass or steel products after application of the preferences provided in this provision may be reduced to a price equal to or lower than the lowest bid or offer price for foreign aluminum, glass or steel products plus the applicable preference. If the reduced bid or offer prices are made in writing and supersede the prior bid or offer prices, all bids or offers, including the reduced bid or offer prices, will be reevaluated in accordance with this rule.

45. INTERESTED PARTY SUPPLEMENTAL DISCLOSURE: W. Va. Code § 6D-1-2 requires that for contracts with an actual or estimated value of at least \$100,000, the vendor must submit to the Agency a supplemental disclosure of interested parties reflecting any new or differing interested parties to the contract, which were not included in the original pre-award interested party disclosure, within 30 days following the completion or termination of the contract. A copy of that form is included with this solicitation or can be obtained from the WV Ethics Commission. "Interested parties" means: (1) A business entity performing work or service pursuant to, or in furtherance of, the applicable contract, including specifically sub-contractors; (2) the person(s) who have an ownership interest equal to or greater than 25% in the business entity performing work or service pursuant to, or in furtherance of, the applicable contract; and (3) the person or business entity, if any, that served as a compensated broker or intermediary to actively facilitate the applicable contract or negotiated the terms of the applicable contract with the state agency: Provided, That subdivision (2) shall be inapplicable if a business entity is a publicly traded company: Provided, however, That subdivision (3) shall not include persons or business entities performing legal services related to the negotiation or drafting of the applicable contract. The Agency shall submit a copy of the disclosure to the Ethics Commission within 15 days after receiving the supplemental disclosure of interested parties.

ADDITIONAL TERMS AND CONDITIONS (Construction Contracts Only)

1. CONTRACTOR'S LICENSE: West Virginia Code § 21-11-2 requires that all persons desiring to perform contracting work in this state be licensed. The West Virginia Contractors Licensing Board is empowered to issue the contractor's license. Applications for a contractor's license may be made by contacting the West Virginia Division of Labor. West Virginia Code § 21-11-11 requires any prospective Vendor to include the contractor's license number on its bid. If an apparent low bidder fails to submit a license number in accordance with this section, the Purchasing Division will promptly request by telephone and electronic mail that the low bidder and the second low bidder provide the license number within one business day of the request. Failure of the bidder to provide the license number within one business day of receiving the request shall result in disqualification of the bid. Vendors should include a contractor's license number in the space provided below.

Contractor's Name: Gregori Construction Inc.
Contractor's License No.: WV- 038242

The apparent successful Vendor must furnish a copy of its contractor's license prior to the issuance of a contract award document.

2. DRUG-FREE WORKPLACE AFFIDAVIT: W. Va. Code § 21-1D-5 provides that any solicitation for a public improvement contract requires each Vendor that submits a bid for the work to submit an affidavit that the Vendor has a written plan for a drug-free workplace policy. If the affidavit is not submitted with the bid submission, the Purchasing Division shall promptly request by telephone and electronic mail that the low bidder and second low bidder provide the affidavit within one business day of the request. Failure to submit the affidavit within one business day of receiving the request shall result in disqualification of the bid. To comply with this law, Vendor should complete the enclosed drug-free workplace affidavit and submit the same with its bid. Failure to submit the signed and notarized drugfree workplace affidavit or a similar affidavit that fully complies with the requirements of the applicable code, within one business day of being requested to do so shall result in disqualification of Vendor's bid. Pursuant to W. Va. Code 21-1D-2(b) and (k), this provision does not apply to public improvement contracts the value of which is \$100,000 or less or temporary or emergency repairs.

2.1. DRUG-FREE WORKPLACE POLICY: Pursuant to W. Va. Code § 21-1D-4, Vendor and its subcontractors must implement and maintain a written drug-free workplace policy that complies with said article. The awarding public authority shall cancel this contract if: (1) Vendor fails to implement and maintain a written drug-free workplace policy described in the preceding paragraph, (2) Vendor fails to provide information regarding implementation of its drug-free workplace policy at the request of the public authority; or (3) Vendor provides to the public authority false information regarding the contractor's drug-free workplace policy.

Pursuant to W. Va. Code 21-1D-2(b) and (k), this provision does not apply to public improvement contracts the value of which is \$100,000 or less or temporary or emergency repairs.

3. DRUG FREE WORKPLACE REPORT: Pursuant to W. Va. Code § 21-1D-7b, no less than once per year, or upon completion of the project, every contractor shall provide a certified report to the public authority which let the contract. For contracts over \$25,000, the public authority shall be the West Virginia Purchasing Division. For contracts of \$25,000 or less, the public authority shall be the agency issuing the contract. The report shall include:

- (1) Information to show that the education and training service to the requirements of West Virginia Code § 21-1D-5 was provided;
- (2) The name of the laboratory certified by the United States Department of Health and Human Services or its successor that performs the drug tests;
- (3) The average number of employees in connection with the construction on the public improvement;
- (4) Drug test results for the following categories including the number of positive tests and the number of negative tests: (A) Pre-employment and new hires; (B) Reasonable suspicion; (C) Post-accident; and (D) Random.

Vendor should utilize the attached Certified Drug Free Workplace Report Coversheet when submitting the report required hereunder. Pursuant to W. Va. Code 21-1D-2(b) and (k), this provision does not apply to public improvement contracts the value of which is \$100,000 or less or temporary or emergency repairs.

4. AIA DOCUMENTS: All construction contracts that will be completed in conjunction with architectural services procured under Chapter 5G of the West Virginia Code will be governed by the AIA A101-2007 and A201-2007 or the A107-2007 documents, as amended by the Supplementary Conditions for the State of West Virginia, in addition to the terms and conditions contained herein.

4A. PROHIBITION AGAINST GENERAL CONDITIONS: Notwithstanding anything contained in the AIA Documents or the Supplementary Conditions, the State of West Virginia will not pay for general conditions, or winter conditions, or any other condition representing a delay in the contracts. The Vendor is expected to mitigate delay costs to the greatest extent possible and any costs associated with Delays must be specifically and concretely identified. The state will not consider an average daily rate multiplied by the number of days extended to be an acceptable charge.

5. GREEN BUILDINGS MINIMUM ENERGY STANDARDS: In accordance with § 22-29-4, all new building construction projects of public agencies that have not entered the schematic design phase prior to July 1, 2012, or any building construction project receiving state grant funds and appropriations, including public schools, that have not entered the schematic design phase prior to July 1, 2012, shall be designed and constructed complying with the ICC International Energy Conservation Code, adopted by the State Fire Commission, and the ANSI/ASHRAE/IESNA Standard 90.1-2007: Provided, That if any construction project has a commitment of federal funds to pay for a portion of such project, this provision shall only apply to the extent such standards are consistent with the federal standards.

6. LOCAL LABOR MARKET HIRING REQUIREMENT: Pursuant to West Virginia Code §21-1C-1 et seq., Employers shall hire at least seventy-five percent of employees for public improvement construction projects from the local labor market, to be rounded off, with at least two employees from outside the local labor market permissible for each employer per project.

Any employer unable to employ the minimum number of employees from the local labor market shall inform the nearest office of Workforce West Virginia of the number of qualified employees needed and provide a job description of the positions to be filled.

If, within three business days following the placing of a job order, Workforce West Virginia is unable to refer any qualified job applicants to the employer or refers less qualified job applicants than the number requested, then Workforce West Virginia shall issue a waiver to the employer stating the unavailability of applicant and shall permit the employer to fill any positions covered by the waiver from outside the local labor market. The waiver shall be either oral or in writing and shall be issued within the prescribed three days. A waiver certificate shall be sent to both the employer for its permanent project records and to the public authority.

Any employer who violates this requirement is subject to a civil penalty of \$250 per each employee less than the required threshold of seventy-five percent per day of violation after receipt of a notice of violation.

Any employer that continues to violate any provision of this article more than fourteen calendar days after receipt of a notice of violation is subject to a civil penalty of \$500 per each employee less than the required threshold of seventy-five percent per day of violation.

The following terms used in this section have the meaning shown below.

(1) The term "construction project" means any construction, reconstruction, improvement, enlargement, painting, decorating or repair of any public improvement let to contract in an amount equal to or greater than \$500,000. The term "construction project" does not include temporary or emergency repairs;

(2) The term "employee" means any person hired or permitted to perform hourly work for wages by a person, firm or corporation in the construction industry; The term "employee" does not include:(i) Bona fide employees of a public authority or individuals engaged in making temporary or emergency repairs;(ii) Bona fide independent contractors; or(iii) Salaried supervisory personnel necessary to assure efficient execution of the employee's work;

(3) The term "employer" means any person, firm or corporation employing one or more employees on any public improvement and includes all contractors and subcontractors;

(4) The term "local labor market" means every county in West Virginia and any county outside of West Virginia if any portion of that county is within fifty miles of the border of West Virginia;

(5) The term "public improvement" includes the construction of all buildings, roads, highways, bridges, streets, alleys, sewers, ditches, sewage disposal plants, waterworks, airports and all other structures that may be let to contract by a public authority, excluding improvements funded, in whole or in part, by federal funds.

7. DAVIS-BACON AND RELATED ACT WAGE RATES:

- The work performed under this contract is federally funded in whole, or in part. Pursuant to _____, Vendors are required to pay applicable Davis-Bacon wage rates.
- The work performed under this contract is not subject to Davis-Bacon wage rates.

8. SUBCONTRACTOR LIST SUBMISSION: In accordance with W. Va. Code § 5-22-1, the apparent low bidder on a contract valued at more than \$250,000.00 for the construction, alteration, decoration, painting or improvement of a new or existing building or structure shall submit a list of all subcontractors who will perform more than \$25,000.00 of work on the project including labor and materials. (This section does not apply to any other construction projects, such as highway, mine reclamation, water or sewer projects.) The subcontractor list shall be provided to the Purchasing Division within one business day of the opening of bids for review. If the apparent low bidder fails to submit the subcontractor list, the Purchasing Division shall promptly request by telephone and electronic mail that the low bidder and second low bidder provide the subcontractor list within one business day of the request. Failure to submit the subcontractor list within one business day of receiving the request shall result in disqualification of the bid.

If no subcontractors who will perform more than \$25,000.00 of work are to be used to complete the project, the apparent low bidder must make this clear on the subcontractor list, in the bid itself, or in response to the Purchasing Division's request for the subcontractor list.

a. Required Information. The subcontractor list must contain the following information:

- i. Bidder's name
- ii. Name of each subcontractor performing more than \$25,000 of work on the project.
- iii. The license number of each subcontractor, as required by W. Va. Code § 21-11-1 et. seq.
- iv. If applicable, a notation that no subcontractor will be used to perform more than \$25,000.00 of work. (This item iv. is not required if the vendor makes this clear in the bid itself or in documentation following the request for the subcontractor list.)

b. Subcontractor List Submission Form: The subcontractor list may be submitted in any form, including the attached form, as long as the required information noted above is included. If any information is missing from the bidder's subcontractor list submission, it may be obtained from other documents such as bids, emails, letters, etc. that accompany the subcontractor list submission.

c. Substitution of Subcontractor. Written approval must be obtained from the State Spending Unit before any subcontractor substitution is permitted. Substitutions are not permitted unless:

- i. The subcontractor listed in the original bid has filed for bankruptcy;**
- ii. The subcontractor in the original bid has been debarred or suspended; or**
- iii. The contractor certifies in writing that the subcontractor listed in the original bid fails, is unable, or refuses to perform his subcontract.**

Subcontractor List Submission (Construction Contracts Only)

Bidder's Name: Gregori Construction Inc.

Check this box if no subcontractors will perform more than \$25,000.00 of work to complete the project.

Subcontractor Name	License Number if Required by W. Va. Code § 21-11-1 et. seq.
Amtrak Railroad Contractors of Maryland, Inc.	

Attach additional pages if necessary

DESIGNATED CONTACT: Vendor appoints the individual identified in this Section as the Contract Administrator and the initial point of contact for matters relating to this Contract.

Christopher A. Serefine, Estimator
(Name, Title)
Christopher A Serefine, Estimator
(Printed Name and Title)
P.O. Box 121, 736 Exastown Rd, Sarver, VA 16055
(Address)
724-353-1322 / 724-353-2486
(Phone Number) / (Fax Number)
cserefine@gregori-inc.com
(email address)

CERTIFICATION AND SIGNATURE: By signing below, or submitting documentation through wvOASIS, I certify that I have reviewed this Solicitation in its entirety; that I understand the requirements, terms and conditions, and other information contained herein; that this bid, offer or proposal constitutes an offer to the State that cannot be unilaterally withdrawn; that the product or service proposed meets the mandatory requirements contained in the Solicitation for that product or service, unless otherwise stated herein; that the Vendor accepts the terms and conditions contained in the Solicitation, unless otherwise stated herein; that I am submitting this bid, offer or proposal for review and consideration; that I am authorized by the vendor to execute and submit this bid, offer, or proposal, or any documents related thereto on vendor's behalf; that I am authorized to bind the vendor in a contractual relationship; and that to the best of my knowledge, the vendor has properly registered with any State agency that may require registration.

Gregori Construction Inc.
(Company)
Anthony Lascola, V.P.
(Authorized Signature) (Representative Name, Title)
Anthony Lascola, V.P.
(Printed Name and Title of Authorized Representative)
6/11/18
(Date)
724-353-1322 / 724-353-2486
(Phone Number) (Fax Number)

ADDENDUM ACKNOWLEDGEMENT FORM
SOLICITATION NO.: RMA180000007

Instructions: Please acknowledge receipt of all addenda issued with this solicitation by completing this addendum acknowledgment form. Check the box next to each addendum received and sign below. Failure to acknowledge addenda may result in bid disqualification.

Acknowledgment: I hereby acknowledge receipt of the following addenda and have made the necessary revisions to my proposal, plans and/or specification, etc.

Addendum Numbers Received:

(Check the box next to each addendum received)

- | | |
|--|--|
| <input checked="" type="checkbox"/> Addendum No. 1 | <input type="checkbox"/> Addendum No. 6 |
| <input checked="" type="checkbox"/> Addendum No. 2 | <input type="checkbox"/> Addendum No. 7 |
| <input type="checkbox"/> Addendum No. 3 | <input type="checkbox"/> Addendum No. 8 |
| <input type="checkbox"/> Addendum No. 4 | <input type="checkbox"/> Addendum No. 9 |
| <input type="checkbox"/> Addendum No. 5 | <input type="checkbox"/> Addendum No. 10 |

I understand that failure to confirm the receipt of addenda may be cause for rejection of this bid. I further understand that that any verbal representation made or assumed to be made during any oral discussion held between Vendor's representatives and any state personnel is not binding. Only the information issued in writing and added to the specifications by an official addendum is binding.

Gregori Construction Inc.

Company

Anthony Lascola

Authorized Signature

6/11/18

Date

NOTE: This addendum acknowledgement should be submitted with the bid to expedite document processing.

REQUEST FOR QUOTATION
Bridge Repair on the South Branch Valley Railroad

GENERAL CONSTRUCTION SPECIFICATIONS (No AIA Documents)

- 1. PURPOSE AND SCOPE:** The West Virginia Purchasing Division is soliciting bids on behalf of West Virginia State Rail Authority to establish a contract for the following:

Repairs to bridges along the South Branch Valley Railroad (SBVR) as more fully defined Within the specifications.

The Vendor shall furnish all materials, labor, and equipment necessary to complete all Construction Services. The Vendor shall furnish any incidental work, materials, labor, and equipment that are necessary to complete the Construction Services, even if such incidental work is not explicitly included in the Project Plans.

- 2. DEFINITIONS:** The terms listed below shall have the meanings assigned to them below. Additional definitions can be found in section 2 of the General Terms and Conditions and in the Project Plans as defined below.

2.1 “Construction Services” means bridge repairs on the SBVR as more fully described in the Project Plans.

2.2 “Pricing Page” means the pages contained in wvOASIS, attached hereto as Exhibit A, or included in the Project Plans upon which Vendor should list its proposed price for the Construction Services.

2.3 “Solicitation” means the official notice of an opportunity to supply the State with Construction Services that is published by the Purchasing Division.

2.4 “Project Plans” means documents developed by an architect, an engineer, the Agency, or another design professional, which are attached hereto as Exhibit B, that provide detailed instructions on how the Construction Services are to be performed. In the event that Project Plans contain drawings or other documents too large to attach in Exhibit B, Vendors can obtain copies in accordance with Section 9 of these Specifications.

2.5 “Numbering of Bridges” – Bridges are numbered from north to south with the number corresponding to the mileage from the north end of the line at Green Spring.

2.6 “Numbering of Spans, Bents, Piers” – These are all numbered from north to south with span #1 being the most northerly. If there is a bent at the north end of a bridge, it is numbered “1”.

2.7 “Numbering of Girders, Stringers, Posts or Piles” – All girders, stringers, posts or piles on the main line are numbered east to west. For example – S1 on span 5 would

REQUEST FOR QUOTATION
Bridge Repair on the South Branch Valley Railroad

be the fifth span from the north end of the bridge and the first stringer on the east side of that span.

2.8 “Stringer” means a longitudinal bridge girder for supporting part of a deck or railroad track between bents or piers.

2.9 “AREMA” means the American Railway Engineering and Maintenance-of-Way Association (www.AREMA.org)

2.10 “Piles” means A member usually driven or jetted into the ground and deriving its support from the underlying strata and the friction of the ground on its surface. The usual functions of a pile are to carry superimposed load, to compact the surrounding ground, to form a wall to exclude water and soft material or to resist lateral pressure of adjacent ground.

2.11 “Bent” means a part of a bridge substructure. It is a rigid frame which supports the vertical load and is placed transverse to the length of the structure. Bents are commonly used to support beams and girders.

2.12 “Cap” means The upper or bearing part of a bridge pier; designed to distribute concentrated loads evenly over the area of the pier.

3. ORDER OF PRECEDENCE: This General Construction Specifications document will have priority over, and supersede, anything contained in the Project Plans.

4. QUALIFICATIONS: Vendor, or Vendor’s staff if requirements are inherently limited to individuals rather than corporate entities, shall have the following minimum qualifications:

4.1. Experience: Vendor, or Vendor’s supervisory staff assigned to this project, must have successfully completed at least five projects that involved work similar to that described in these specifications or the Project Plans. Compliance with this experience requirement will be determined prior to contract award by the State through references provided by the Vendor upon request, through knowledge or documentation of the Vendor’s past projects, through confirmation of experience, or some other method that the State determines to be acceptable.

Vendor must provide any documentation requested by the State to assist in confirmation of compliance with this provision. References, documentation, or other information to confirm compliance with this experience requirement may be requested after bid opening and prior to contract award.

REQUEST FOR QUOTATION
Bridge Repair on the South Branch Valley Railroad

- 5. PRICING PAGES:** Vendor should electronically enter the information into the Pricing Pages through wvOASIS, if available, or as an electronic document.

Vendors can download the electronic copy of the Pricing Pages from the wvOASIS Vendor Self-Service (VSS) website. If responding with a paper bid, Vendors should download and/or print the assembled CRFQ document (with the highest version number) from wvOASIS and insert their unit price and extended cost for each line item.

- 6. CONTRACT AWARD:** The Contract is intended to provide Agency with a purchase price for the Construction Services. The Contract will be awarded to the lowest qualified responsible bidder meeting the required specifications. If the Pricing Pages contain alternates/add-ons, the Contract will be awarded based on the grand total of the base bid and any alternates/add-ons selected.
- 7. SELECTION OF ALTERNATES:** Pursuant to W. Va. Code § 5-22-1(e), if the Pricing Pages contain alternates/add-ons, there must be no more than seven listed, and the alternates/add-ons will be selected in the order of priority listed on the Pricing Pages. The first alternate/add-on must be selected before the second alternate/add-on can be selected and so on. Provided, that Agency may accept an alternate out of the listed order if acceptance would not affect determination of the lowest qualified responsible bidder. Any unaccepted alternate contained within a bid shall expire one hundred fifty days after the date of the opening of bids for review.
- 8. PERFORMANCE:** Vendor shall perform the Construction Services in accordance with this document and the Project Plans.
- 9. SUBSTITUTIONS:** Any substitution requests must be submitted in accordance with the official question and answer period described in the INSTRUCTIONS TO VENDORS SUBMITTING BIDS, Paragraph 4. Vendor Question Deadline. Vendors submitting substitution requests should submit product brochures and product specifications during the official question and answer period.
- 10. PROJECT PLANS:** The checked box will apply to Project Plans for this solicitation.

- X No Additional Project Plan Documents:** There are no additional Project Plans other than those attached hereto as Exhibit B or any subsequent addenda modifying Exhibit B.

REQUEST FOR QUOTATION
Bridge Repair on the South Branch Valley Railroad

- **Additional Project Plan Documents:** There are additional Project Plan documents other than those attached as Exhibit B. Copies of the additional Project Plan documents not attached as Exhibit B can be obtained by contacting the entity identified below.

11. CONDITIONS OF THE WORK

11.1. Permits: The Vendor shall procure all necessary permits and licenses to comply with all applicable Federal, State, or Local laws, regulations and ordinances of any regulating body.

11.2. Existing Conditions: If discrepancies are discovered between the existing conditions and those noted in the specifications, Vendor must immediately notify the Agency's representative. Vendor must also immediately notify the Agency if suspected hazardous materials are encountered.

11.3. Standard Work Hours: The standard hours of work for this Contract will be all daylight hours 7 days a week with the understanding that freight trains normally run once per day Monday – Thursday. The excursion train will start May 12, 2018 and runs on Saturdays and Sundays with a 1:00 PM departure from Romney (Mile Post 14) to Sycamore Bridge (Mile Post 31.7) and back. The last Saturday of every month the excursion train will run from Romney to Petersburg and back (Mile Post 14.5 – 51.2). Any work outside of the standard hours of work must be approved in advance at the Agency's sole discretion. A SBVR employee will be with the contractor to give on track protection. The SBVR employee will know the train schedule and when a train is running the vendor must clear all equipment from the track and make sure the track is suitable for train service.

11.4. Project Closeout: Project Closeout shall include the following:

11.4.1. Final Cleanup: Vendor shall perform the final cleanup activities listed below, along with any other final cleanup activities normally associated with the work performed under this Contract, prior to final inspection:

10.4.1.1 Vendor will be responsible for removal and disposal of old all timber and debris.

11.4.2. Final Inspection: Vendor shall participate in a final inspection with the Agency's project manager. The purpose of the final inspection will be to identify deficiencies that need to be remedied prior to Agency's final

REQUEST FOR QUOTATION
Bridge Repair on the South Branch Valley Railroad

acceptance of the work. Vendor shall at all times be obligated to perform in accordance with the Contract and must take all actions necessary to ensure that work complies with requirements of Contract prior to final acceptance. Final acceptance does not waive or release Vendor from its obligation to ensure that work complies with the Contract requirements. Vendor shall submit any warranty documents to the Agency project manager at final inspection.

12. FACILITIES ACCESS: Vendors must be given track access for any work performed on the track. An SBVR employee will provide the on-track protection and radio coordination.

11.1 Vendors may stage equipment at Vanderlip (US 50 near Romney), Petersburg Yard or Moorefield Yard. Contractor will be responsible for getting material to the work site. Vendor must contact agency with three (3) calendar days of delivery to schedule delivery date and time. SBVR Contact: Chesley Koerner – 304-613-5546

13. MISCELLANEOUS:

13.1. Contract Manager: During its performance of this Contract, Vendor must designate and maintain a primary contract manager responsible for overseeing Vendor's responsibilities under this Contract. The Contract manager must be available during normal business hours to address any customer service or other issues related to this Contract. Vendor should list its Contract manager and his or her contact information below.

Contract Manager: Brian Curry

Telephone Number: 724-353-1322

Fax Number: 724-353-2486

Email Address: Bcurry@gregori-inc.com

REQUEST FOR QUOTATION
Bridge Repairs on the South Branch Valley Railroad

EXHIBIT B – PROJECT PLANS

1. GENERAL REQUIREMENTS:

13.1 Mandatory Contract Item Requirements: Contract Item must meet or exceed the mandatory requirements listed below. All work has to meet AREMA standards. Bridge Drawings for each bridge are attached as Attachment A.

13.1.1 Bridge at Mile Post 8.5

13.1.1.1 Replace Post 1 at Bent 4 – 12” x 12” x 13’

13.1.2 Bridge at Mile Post 9.7

13.1.2.1 Add a stringer to go from 3-ply to 4-ply in each span. There are 39 – 12’ spans. Estimate 40- 8” x 16” x 24’ (Bridge drawing shows 3-ply stringer – need a stringer added to make 4-ply on entire bridge.)

13.1.3 Bridge at Mile Post 15.2

13.1.3.1 Replace Pile 1 at Bent 11 – 12” diameter round – 13’ out of ground

13.1.3.2 Replace Pile 4 at Bent 9 – 12” diameter round – 14 ½’ out of ground

13.1.3.2.1 Piles will be replaced by splicing below ground level. Splices will be Strong Tie – Fiber-polymer wrap or equivalent.

13.1.3.2.1.1 Equal characteristics means the wrap must be made from a fiber reinforced polymer.

13.1.4 Bridge at Mile Post 17.1

13.1.4.1 Replace Post 4 at Bent 2 – 12” x 12” x 4 ½’

13.1.4.2 Replace 2 timber braces - 3 ½” x 10” x 24’ on Span 14

REQUEST FOR QUOTATION
Bridge Repairs on the South Branch Valley Railroad

13.1.4.3 Shim top of posts where cap does not bear on it Post 3 at bent 11 and post 4 at bent 14

13.1.5 Bridge at Mile Post 23.2

13.1.5.1 – Gabion retaining walls will be installed per drawings in Attachment B.

13.1.5.2 – The purpose of the installation of new gabion basket end and wing walls as shown in Attachment B is to convert the existing five span bridge to a one span bridge (58' to 15'). It will require a new deck, 8" x 8" x 10' ties, 4 ply 8" x 16" 15' stringers and two new end piers that will set on existing concrete walls.

13.1.6 Bridge at Mile Post 37.4

13.1.6.1 Replace Piles 1, 2 & 3 in Bent 4 – 12" diameter round – 3' out of ground per AREMA Specifications.

13.1.6.2 Piles will be replaced by splicing below ground level.

13.1.6.3 Splices will be Strong Tie – Fiber-polymer wrap or equivalent.

13.1.6.3.1 Equal characteristics means the wrap must be made from a fiber reinforced polymer,

13.1.6.2 Install new cap at Bent 4

13.1.7 Bridge at Mile Post 43.8

13.1.7.1 Replace Bent 3 – 9' foot high

13.1.7.2 Replace S6 in Spans 2 & 3 – 8" x 16" x 24'

REQUEST FOR QUOTATION
Bridge Repairs on the South Branch Valley Railroad

13.1.7.3 Add 4th Stringer over Spans 2 & 3 – 8” x 16” x 24’

13.1.7.4 Add 4th Stringer over Spans 6 & 7 – 8” x 16” x 24’

13.2 Material Specifications

13.2.1 Posts, Piles and stringers

13.2.1.1 – Contractor shall supply all posts, piles and stringers. All material must conform with AREMA specifications. (AREMA.org)

Contractor will be responsible to remove old posts, piles and stringers from the property and dispose of them.

13.2.3 – Bolts

13.2.4.1 – Contractor shall supply new bolts, pins and fasteners required to secure the replacement of bridge material. All scarp bolts, pins, fasteners will be gathered and stacked at Moorefield yard and remain the property of the SRA.

BRIDGE INSPECTION REPORT

APRIL 12, 2017

BRIDGE NO. SBVR-8.5

PLAN & ELEVATION

PAGE 2 OF 3

Attachment "A"

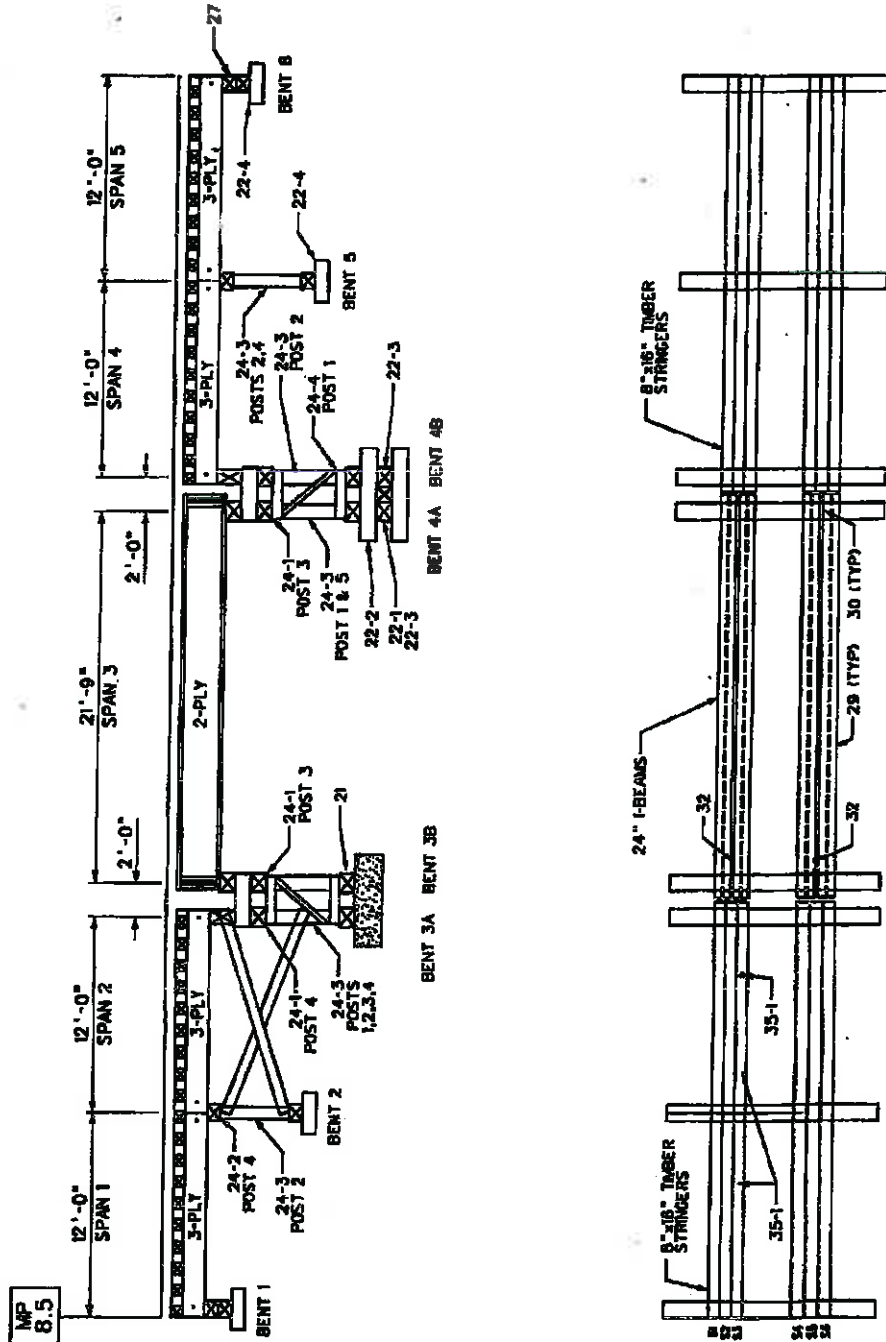

BRIDGE INSPECTION REPORT

APRIL 17, 2017

BRIDGE NO. SBVR-9.7

TYPICAL SECTION VIEW

PAGE: 1

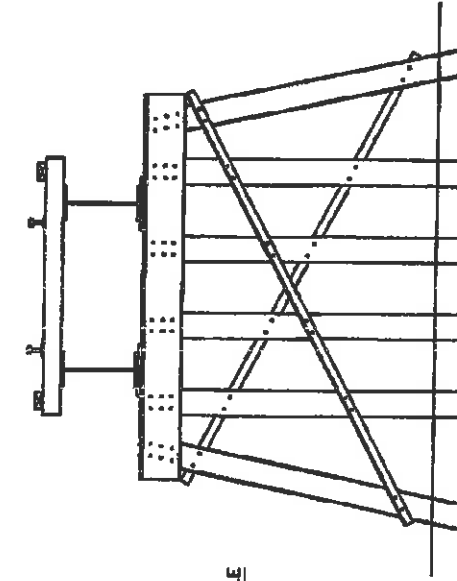

SPAN 1, 36-40: W36X230

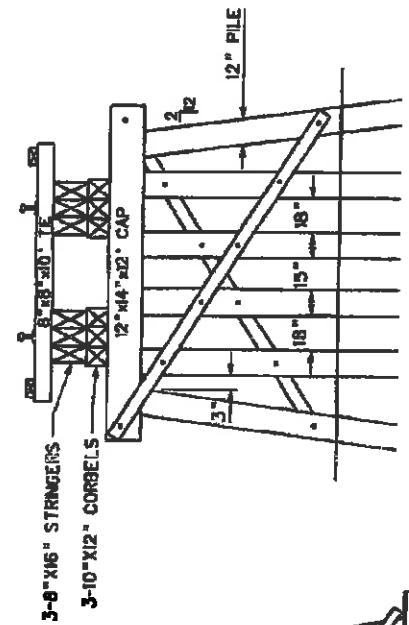

SPAN 2-35: 3-PLY 8\"X16\" TIMBER STRINGERS
SPAN 41-46: 3-PLY 8\"X16\" TIMBER STRINGERS

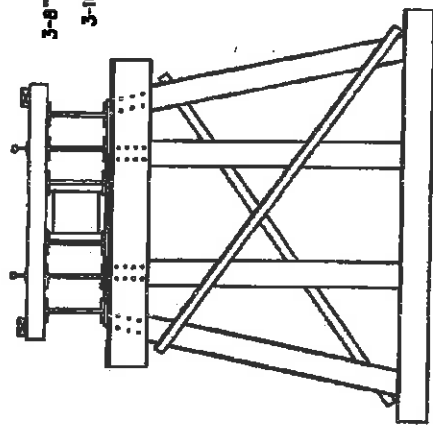

SPAN 47-58: 3-PLY G26X138

BRIDGE INSPECTION REPORT

APRIL 17, 2017

BRIDGE NO. SBVR-9.7

PLAN & ELEVATION

PAGE: 2

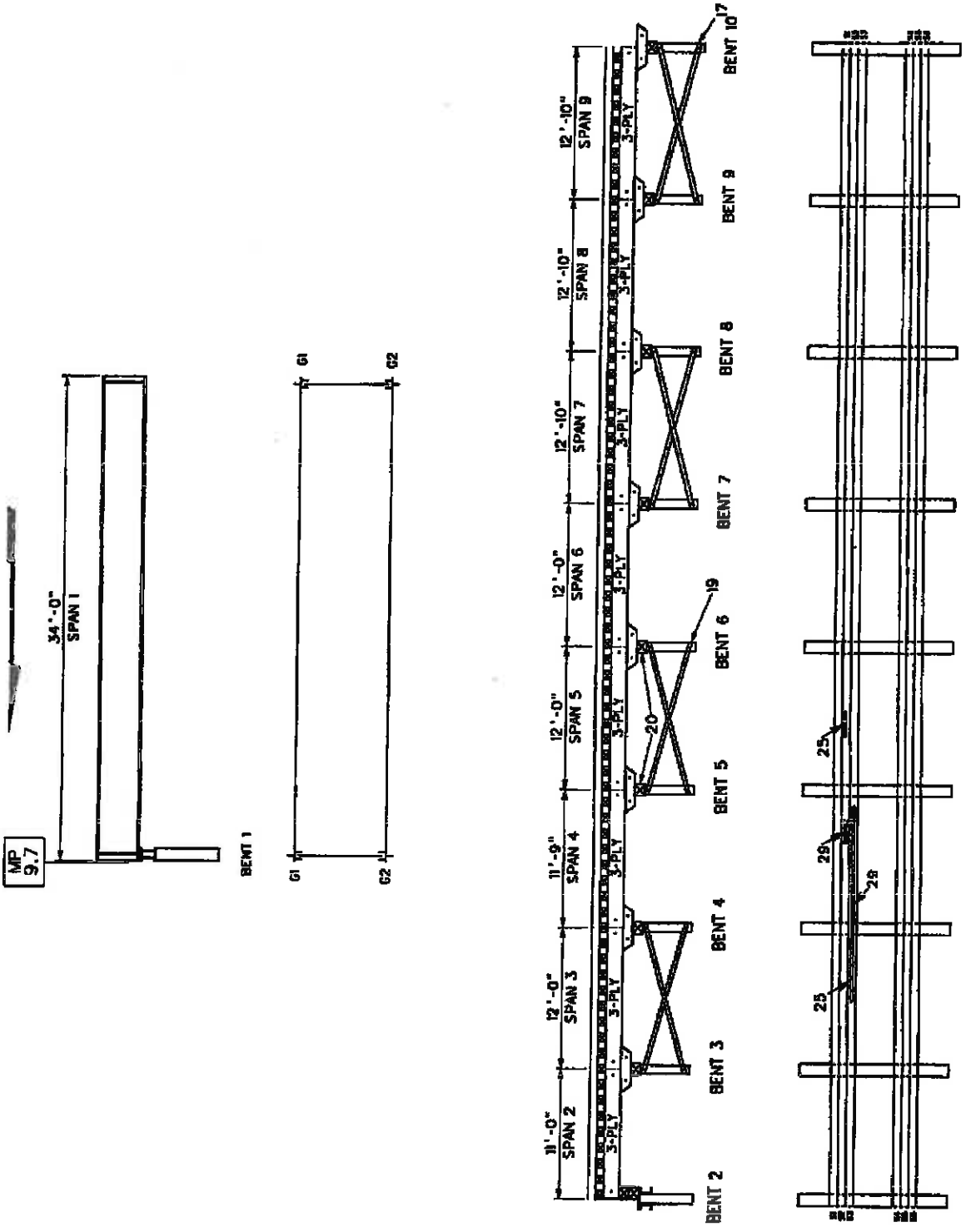

BRIDGE INSPECTION REPORT

APRIL 17, 2017

BRIDGE NO. SBVR-9.7

PLAN & ELEVATION

PAGE: 3 

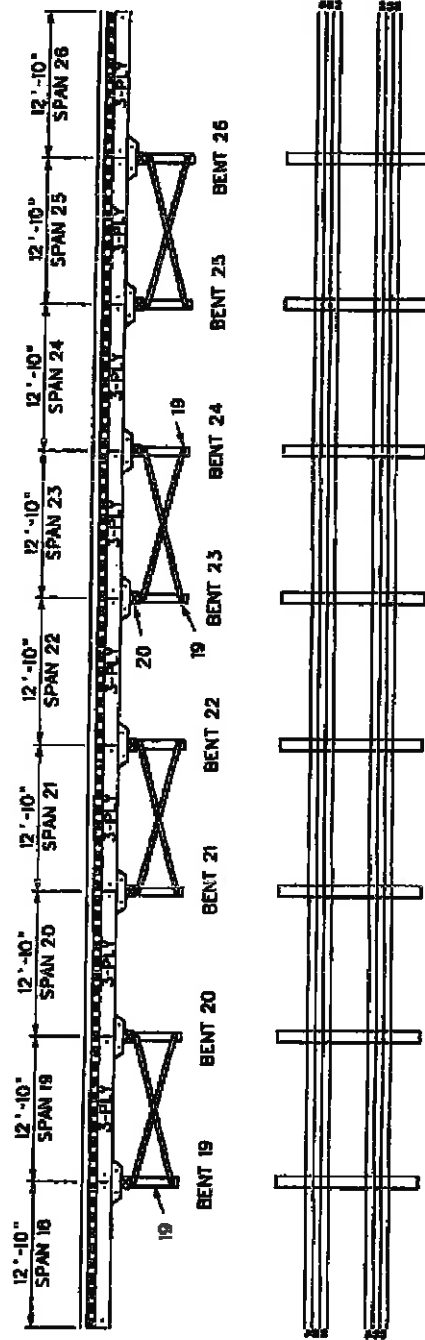
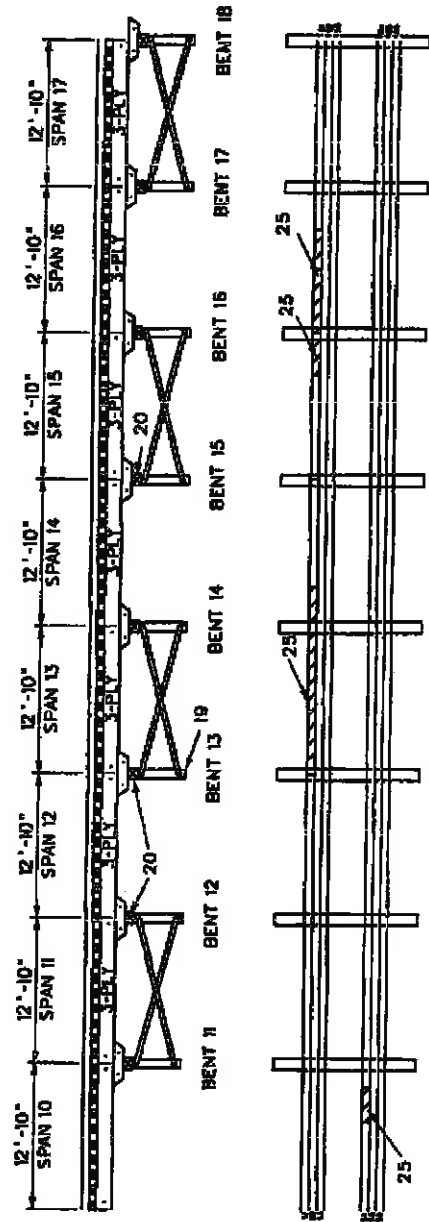

BRIDGE INSPECTION REPORT

APRIL 17, 2017

BRIDGE NO. SBVR-9.7

PLAN & ELEVATION

PAGE: 4 

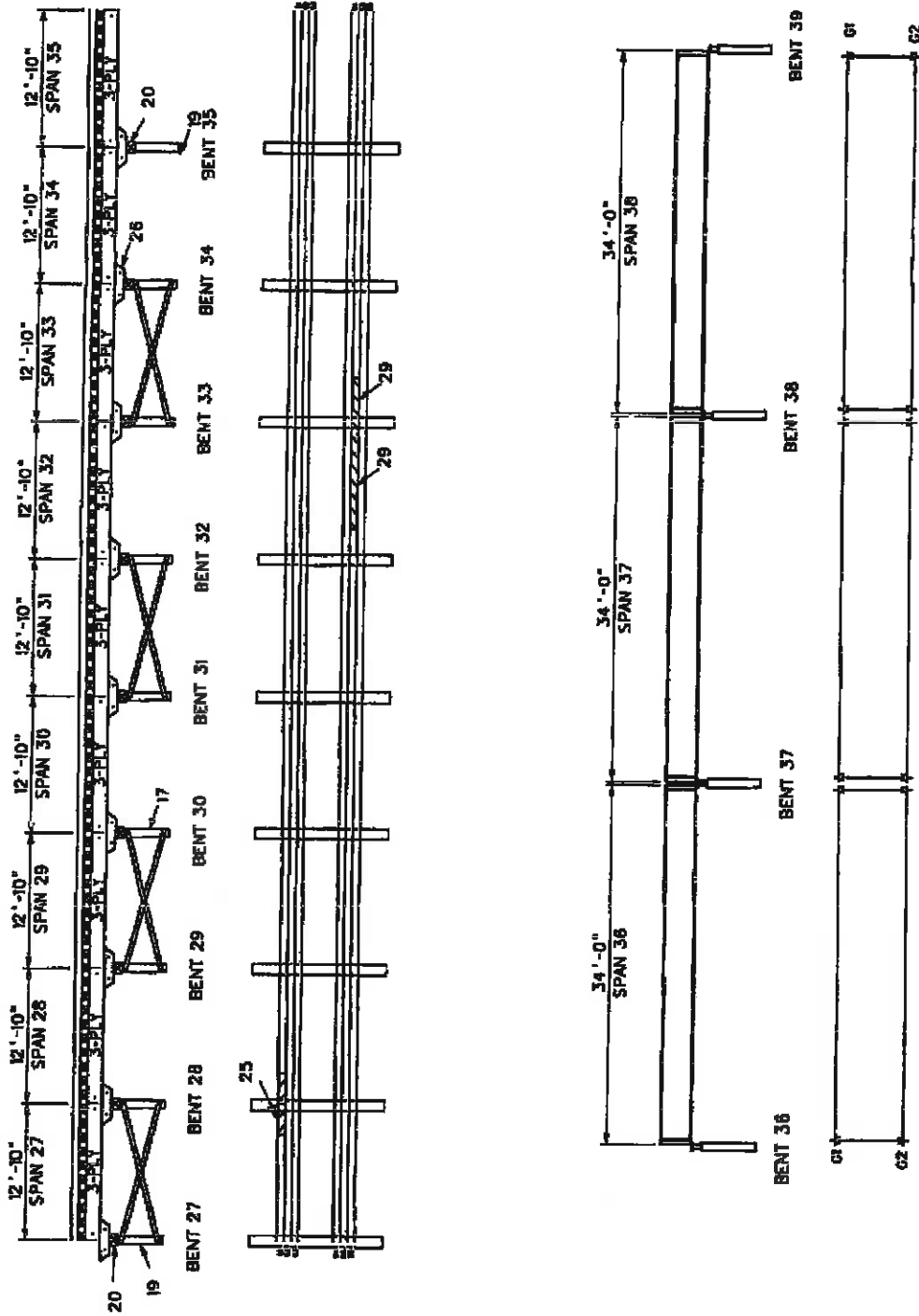

BRIDGE INSPECTION REPORT

APRIL 17, 2017

BRIDGE NO. SBVR-9.7

PLAN & ELEVATION

PAGE: 5

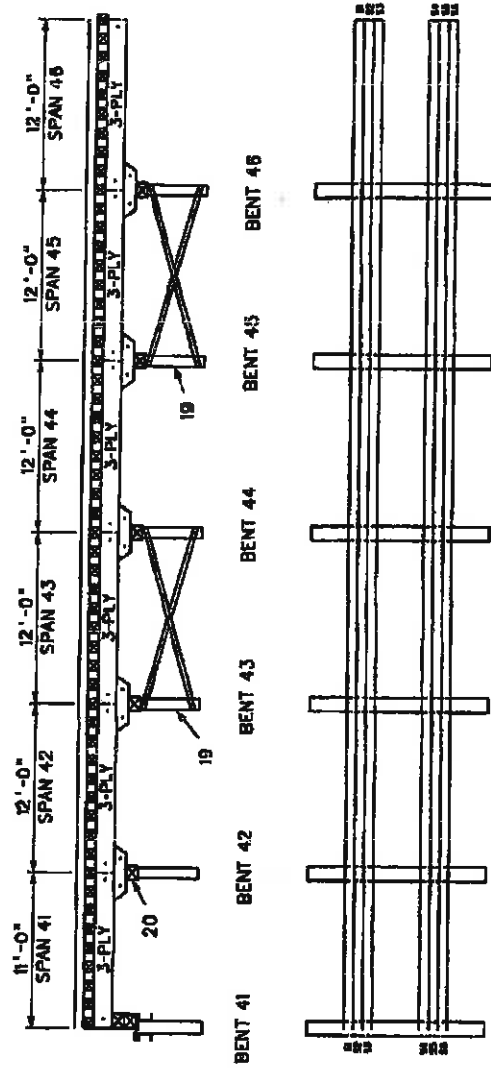
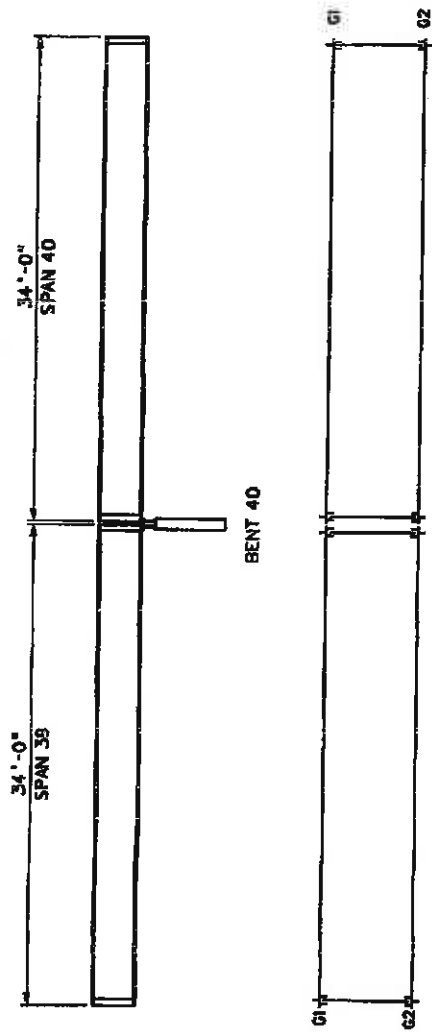

BRIDGE INSPECTION REPORT

APRIL 17, 2017

BRIDGE NO. SBVR-9.7

PLAN & ELEVATION

PAGE: 2 OF 10

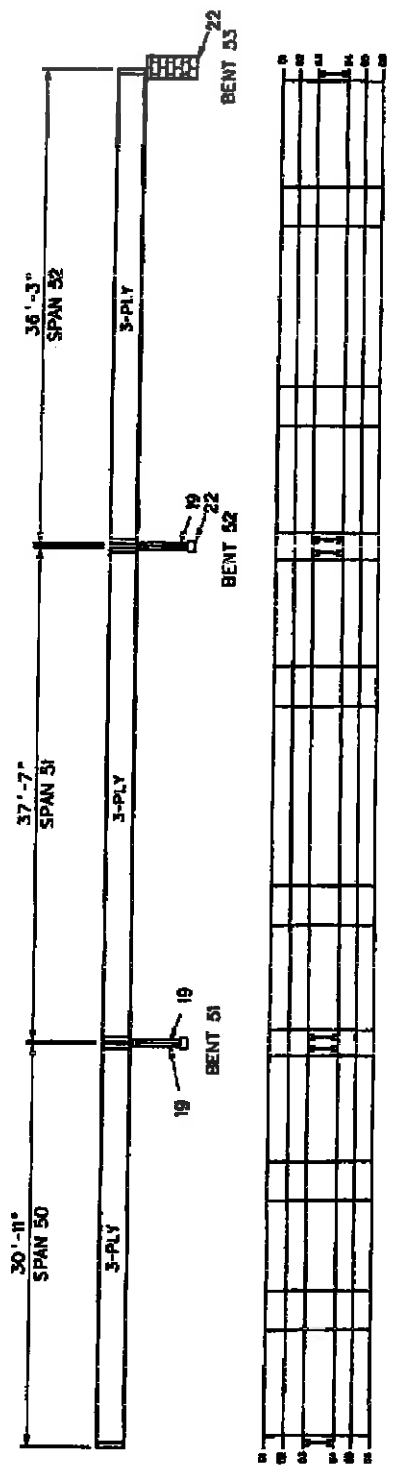
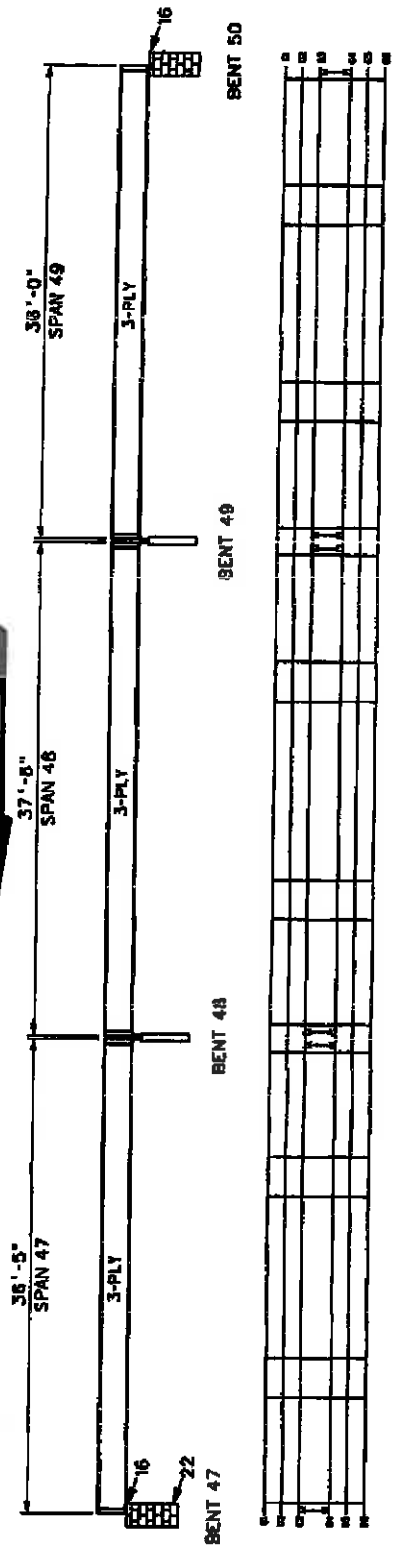

BRIDGE INSPECTION REPORT

APRIL 17, 2017

BRIDGE NO. SBVR-9.7

PLAN & ELEVATION

PAGE: 7

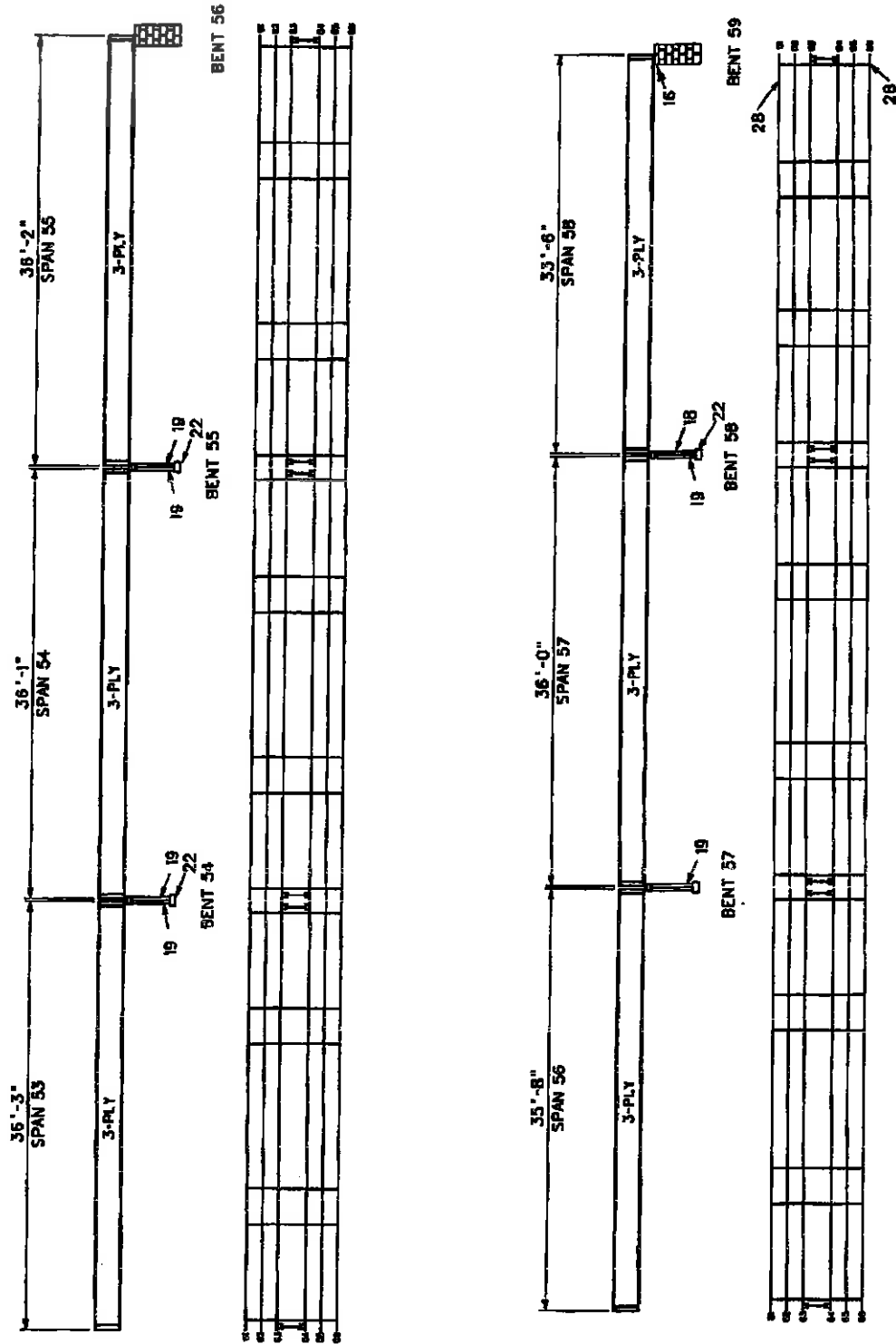

BRIDGE INSPECTION REPORT

APRIL 18, 2017

BRIDGE NO. SBVR-15.2

TYPICAL SECTION VIEW

PAGE: 1 OF 3

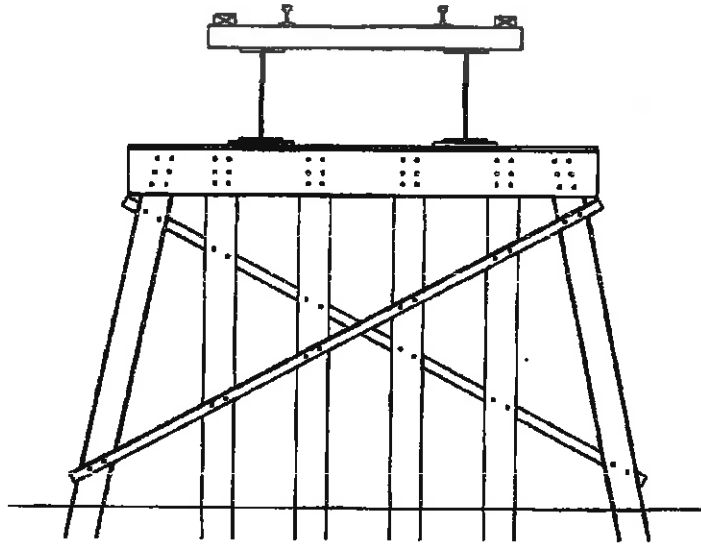

SPAN 16-31: W36X230

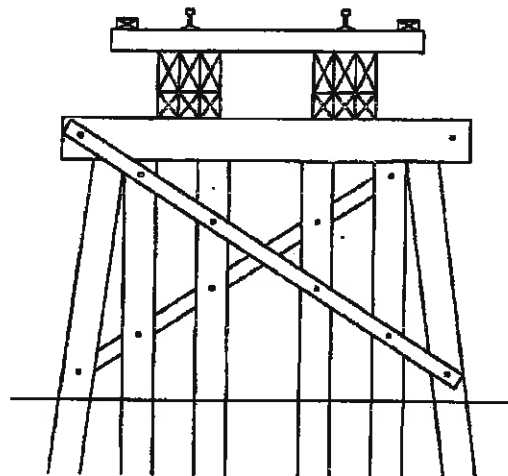

SPAN 1-15: 3-PLY 8"X16" TIMBER STRINGERS
SPAN 38-41: 3-PLY 8"X16" TIMBER STRINGERS

BRIDGE INSPECTION REPORT

APRIL 18, 2017

BRIDGE NO. SBVR-15.2

TYPICAL SECTION VIEW

PAGE: 2 OF 8

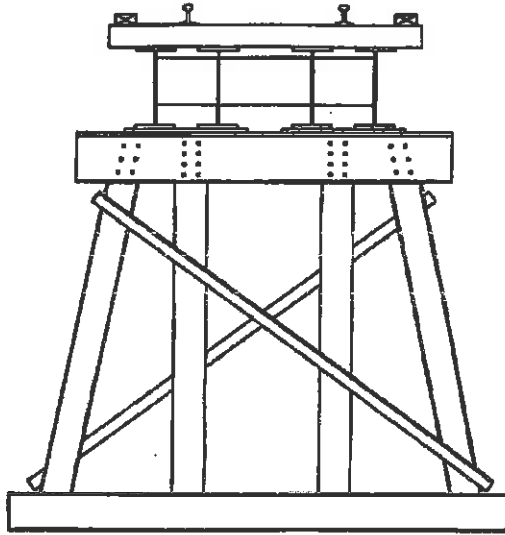

SPAN 32-34: 2-PLY W30X211

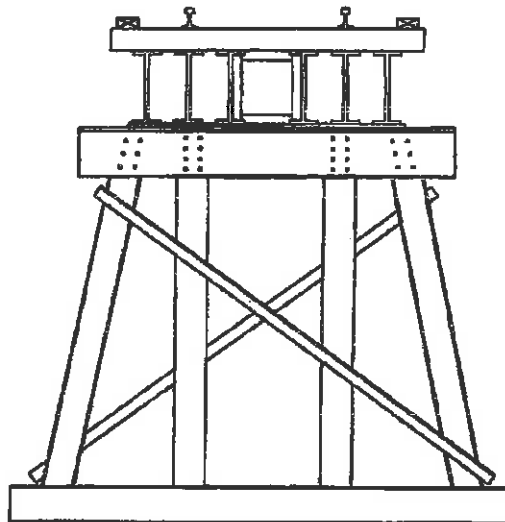

SPAN 35-37: 3-PLY WF26" BEAM

BRIDGE INSPECTION REPORT

APRIL 18, 2017

BRIDGE NO. SBVR-15.2

TYPICAL SECTION VIEW

PAGE: 3 OF 5

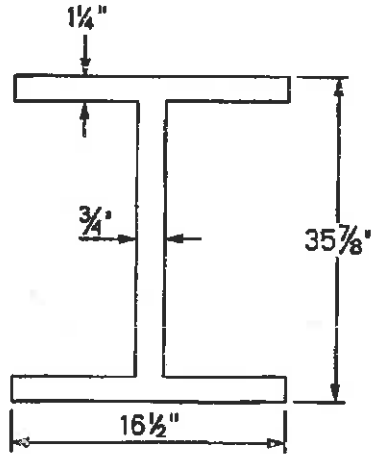

SPAN 16-31: W36X230

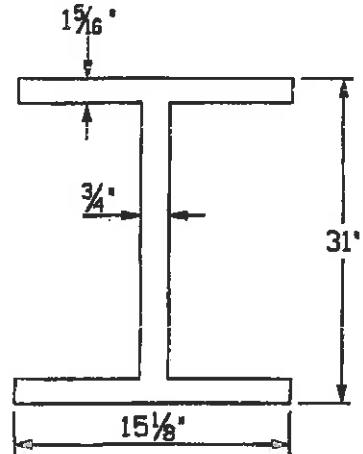

SPAN 32-34: 2-PLY W30X211

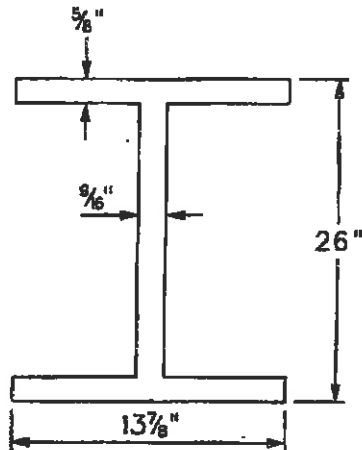

SPAN 35-37: 3 PLY WF26" BEAM

BRIDGE INSPECTION REPORT

APRIL 18, 2017

BRIDGE NO. SBVR-15.2

PLAN & ELEVATION

PAGE: 4 OF 4

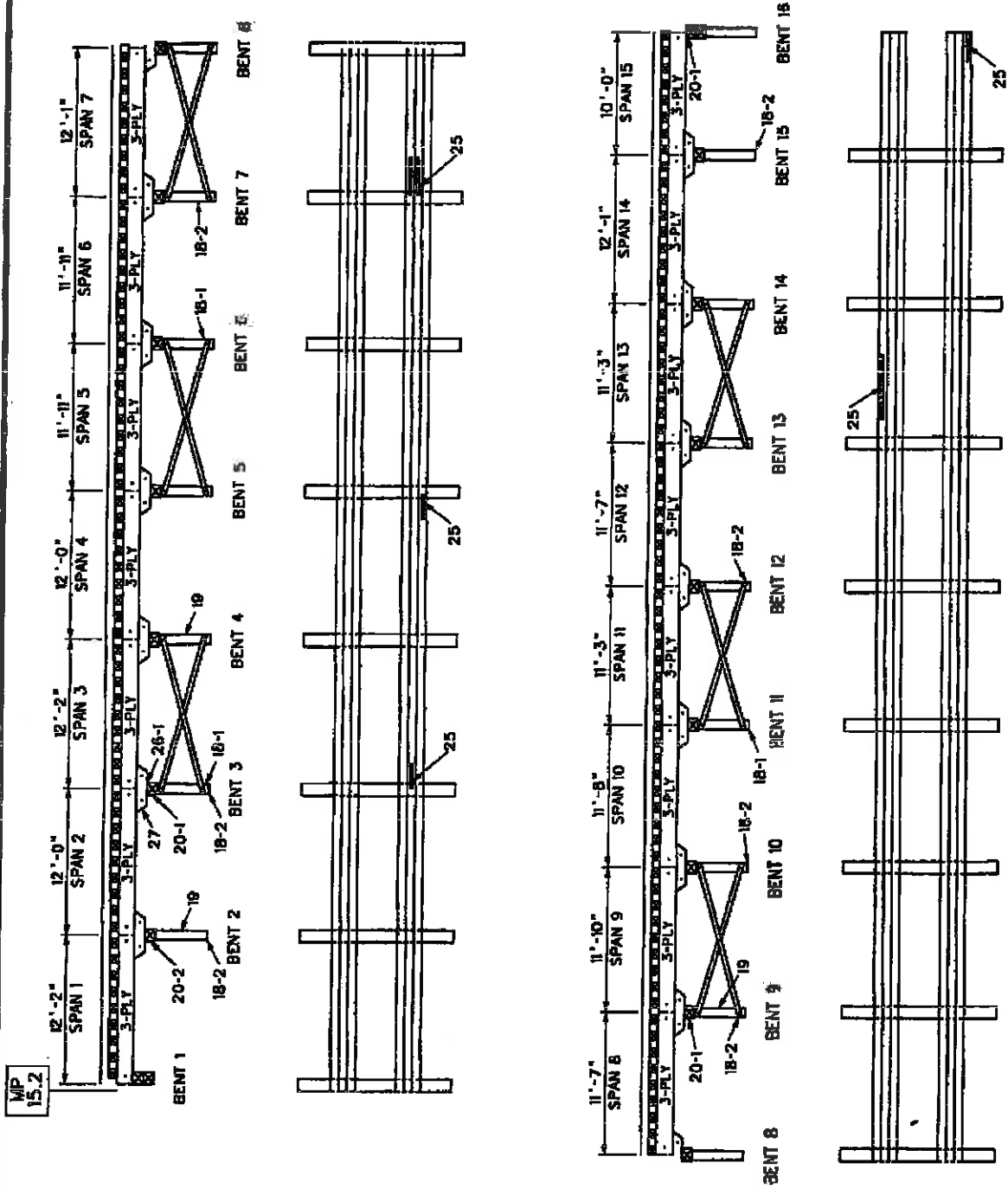

BRIDGE INSPECTION REPORT

APRIL 18, 2017

BRIDGE NO. SBVR-15.2

PLAN & ELEVATION

PAGE: 5 OF 8

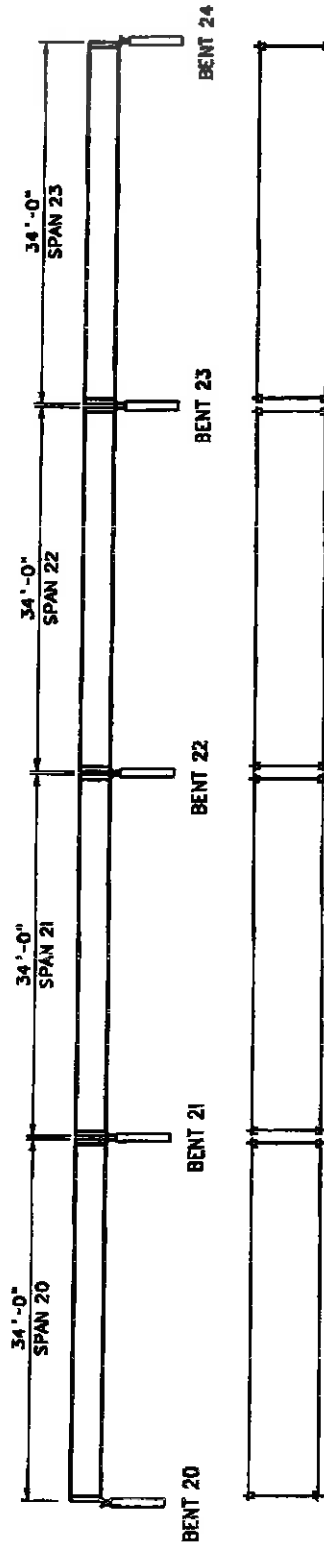
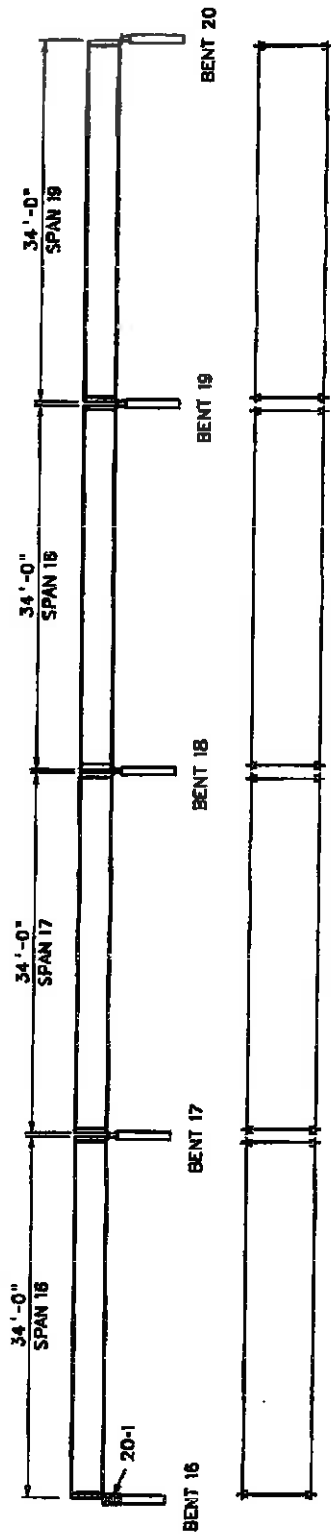

BRIDGE INSPECTION REPORT

APRIL 18, 2017

BRIDGE NO. SBVR-15.2

PLAN & ELEVATION

PAGE: 6 OF 6

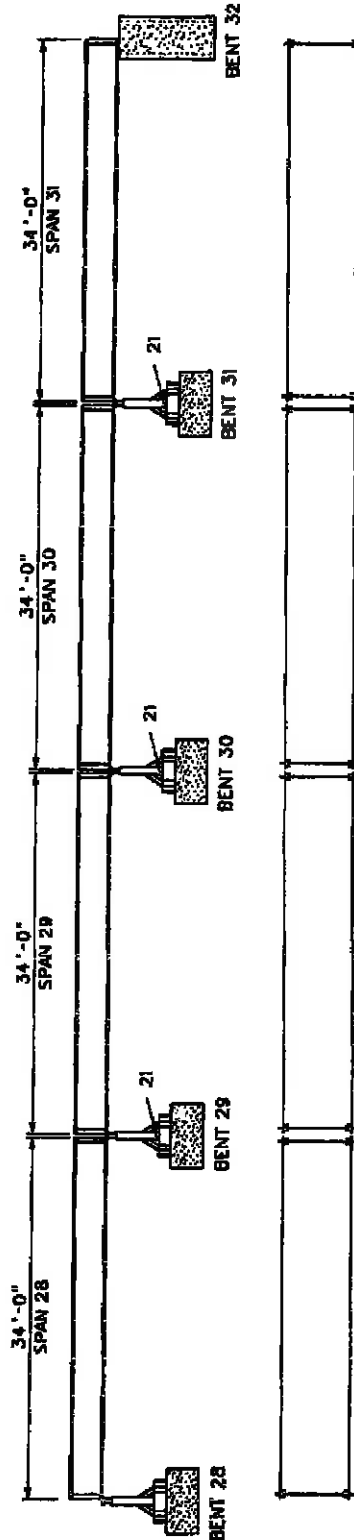
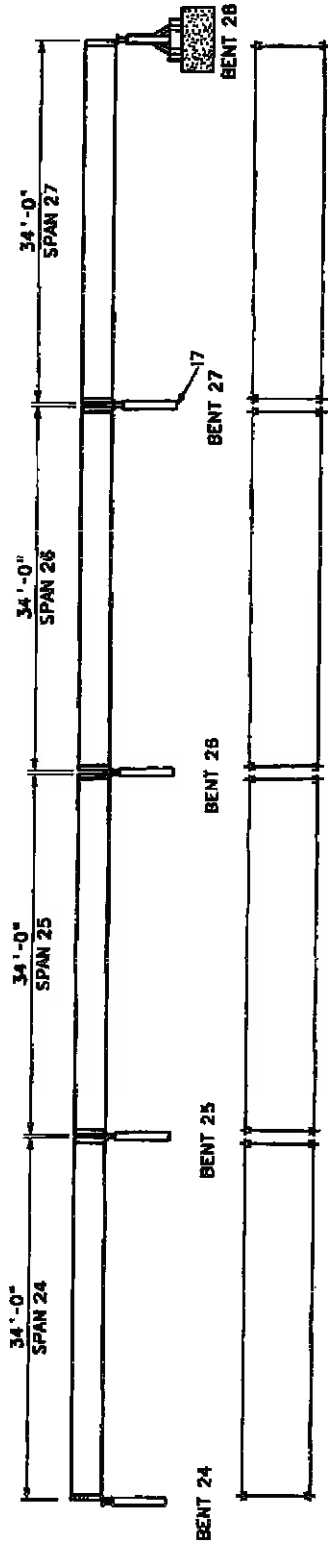

BRIDGE INSPECTION REPORT

APRIL 18, 2017

BRIDGE NO. SBVR-15.2

PLAN & ELEVATION

PAGE: 7 OF 6

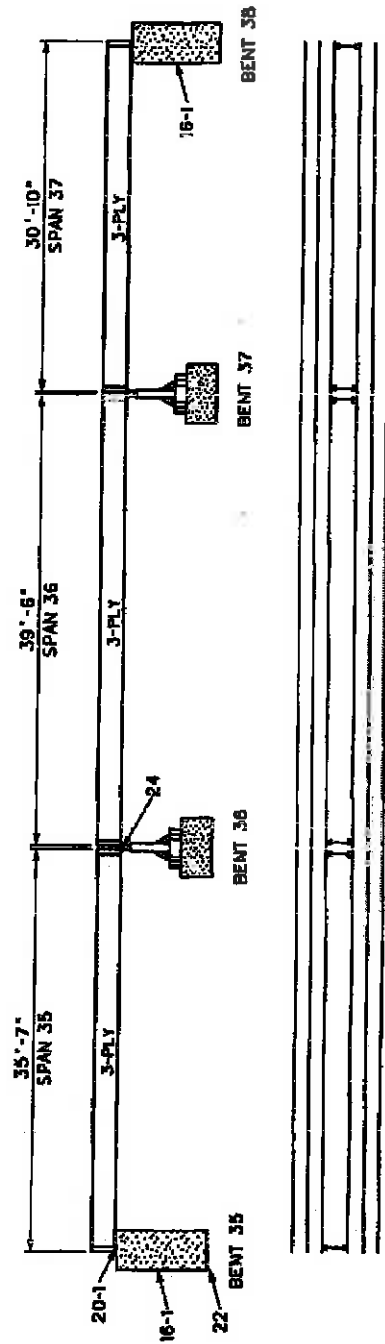
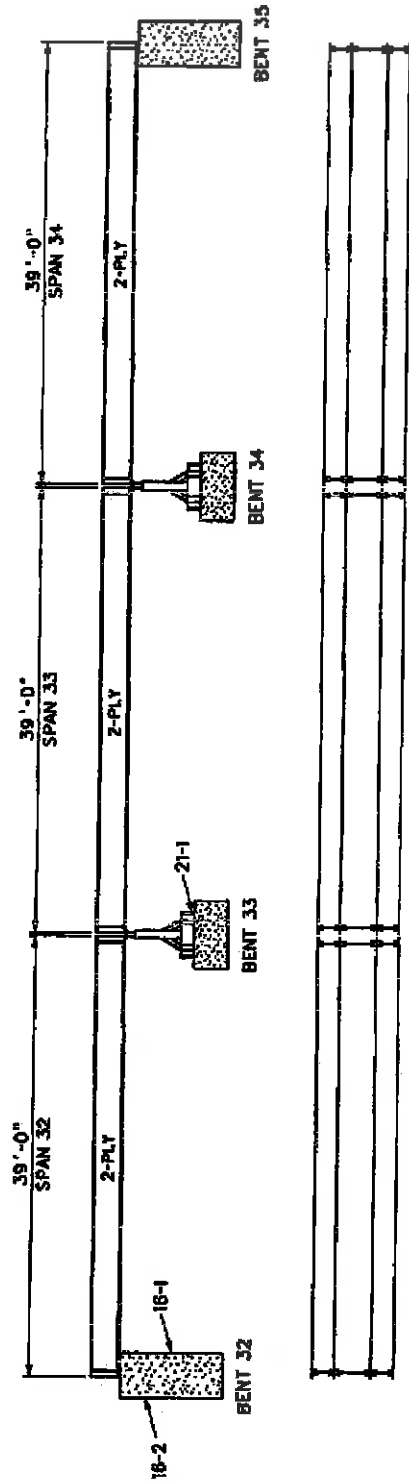

BRIDGE INSPECTION REPORT

APRIL 18, 2017

BRIDGE NO. SBVR-15.2

PLAN & ELEVATION

PAGE: 8 OF 8

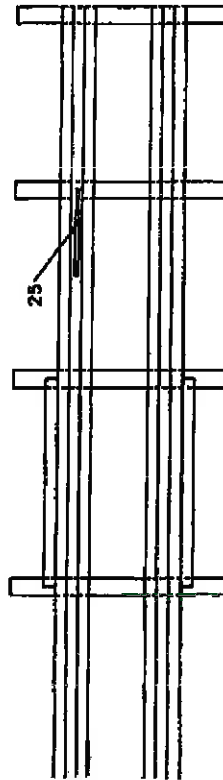
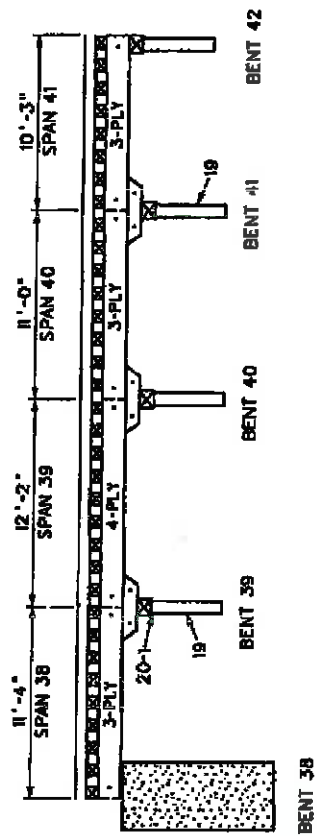

BRIDGE INSPECTION REPORT

APRIL 21, 2017

BRIDGE NO. SBVR-17.1

TYPICAL SECTION VIEW

PAGE: 1 OF 2

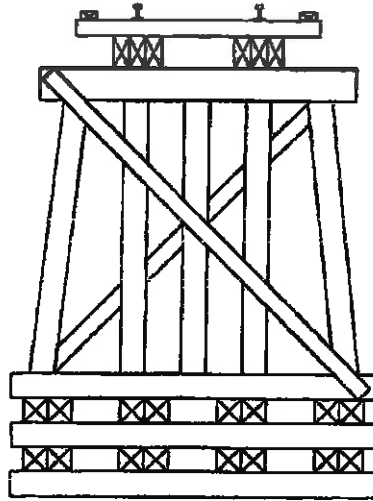

BENT 2-7, 18, 19

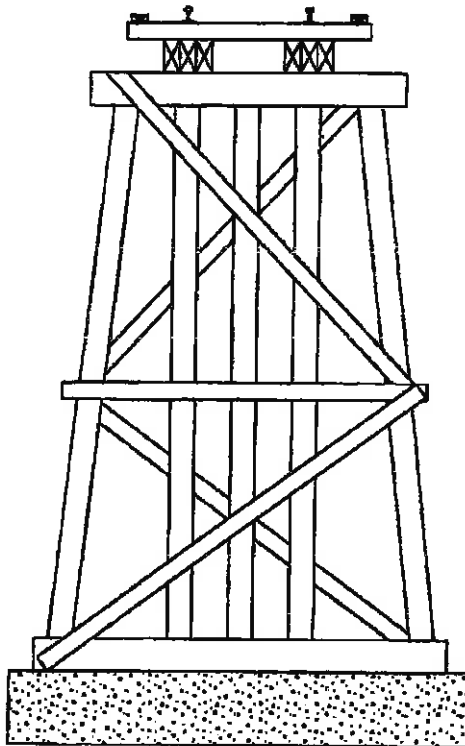

BENT 8-16

BRIDGE INSPECTION REPORT

APRIL 21, 2017

BRIDGE NO. SBVR-17.1

PLAN & ELEVATION

PAGE: 2 OF 2

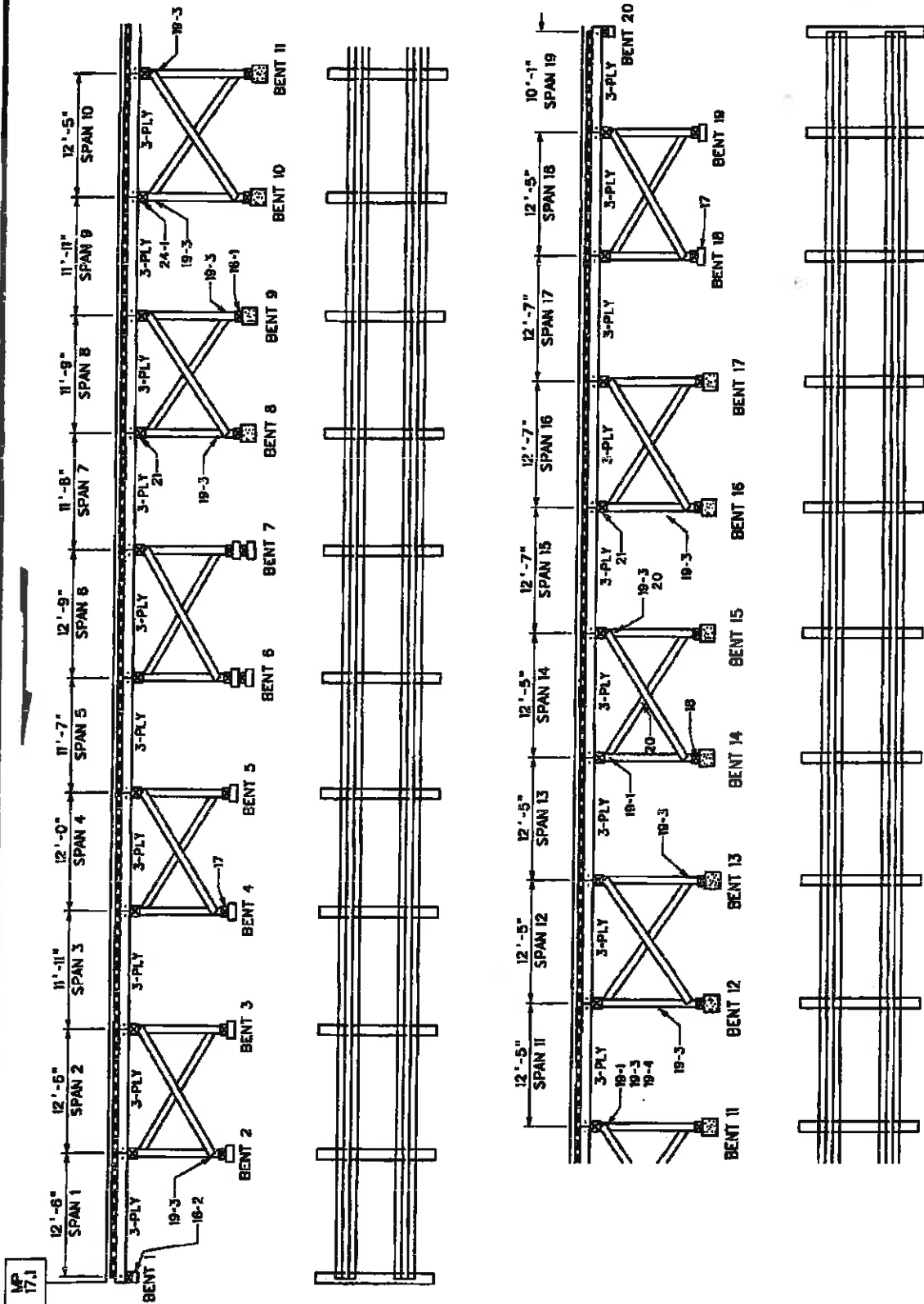

BRIDGE INVENTORY REPORT

APRIL 11, 2017

BRIDGE NO. SBVR-23.2

TYPICAL SECTION VIEW

PAGE: 1 OF 3

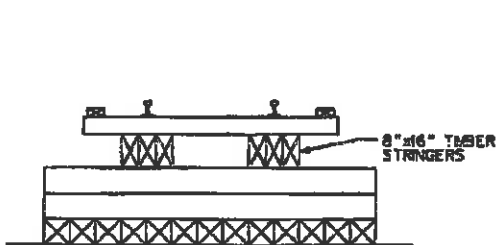

TIMBER WALLS 1 & 6

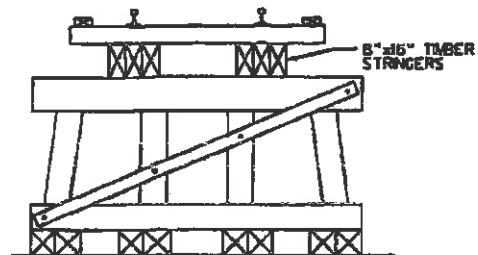

TIMBER FRAME BENT 2

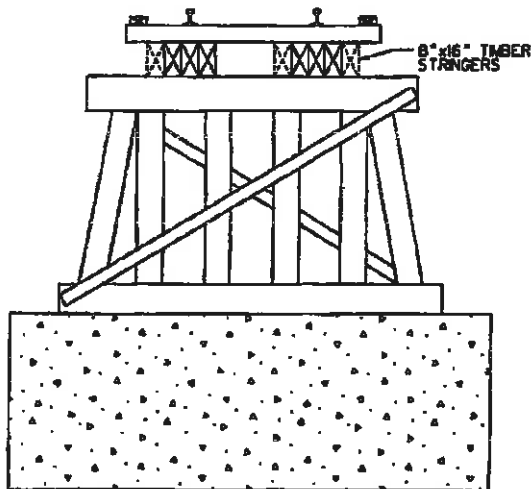

TIMBER FRAME BENTS 3 & 4

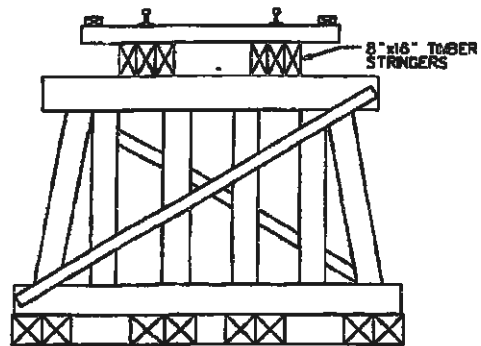

TIMBER FRAME BENT 5

BRIDGE INVENTORY REPORT

APRIL 11, 2017

BRIDGE NO. SBVR-23.2

PLAN & ELEVATION

PAGE: 2 OF 3

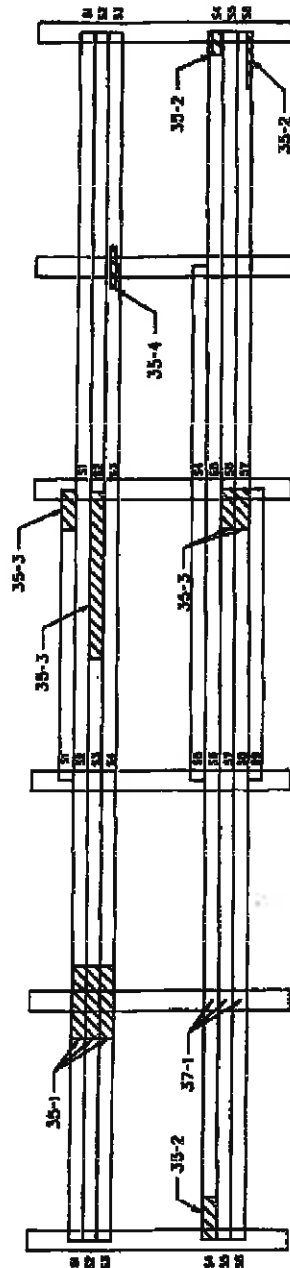
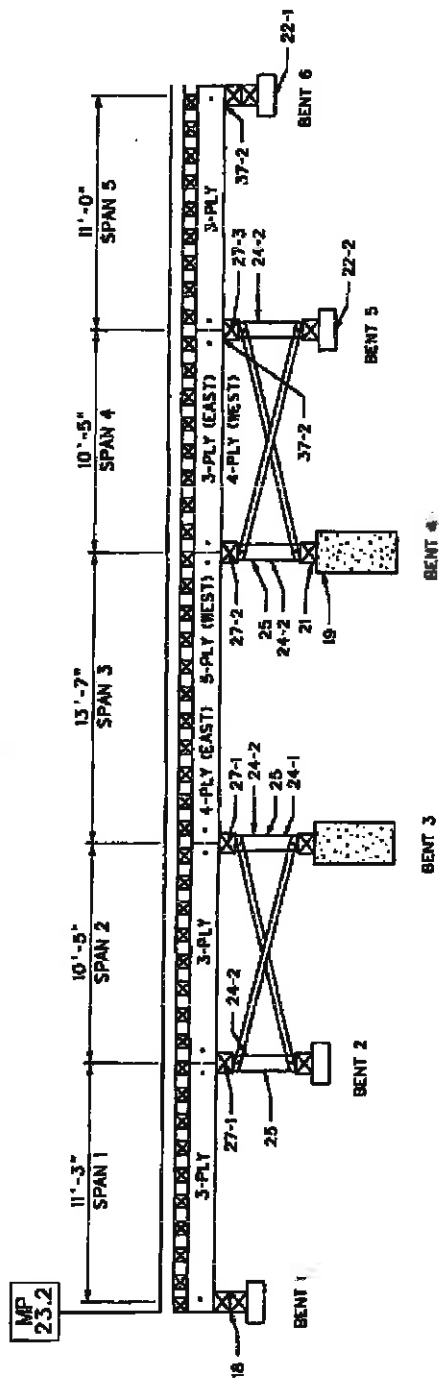

BRIDGE INSPECTION REPORT

APRIL 13, 2017

BRIDGE NO. SBVR-37.4

TYPICAL SECTION VIEW

PAGE: 1 OF 3

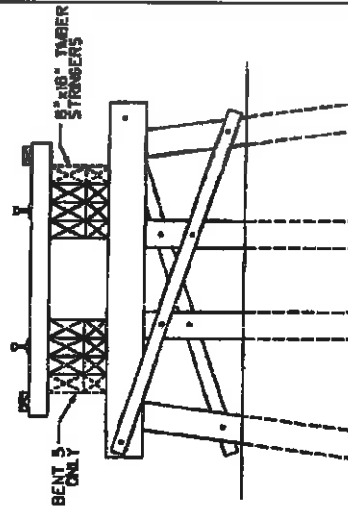

TIMBER PILE
BENTS 3 & 5

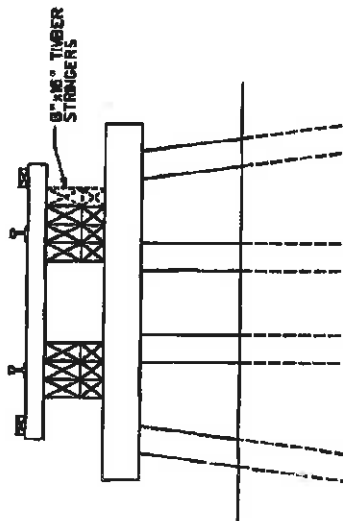

TIMBER PILE
BENTS 2 & 4

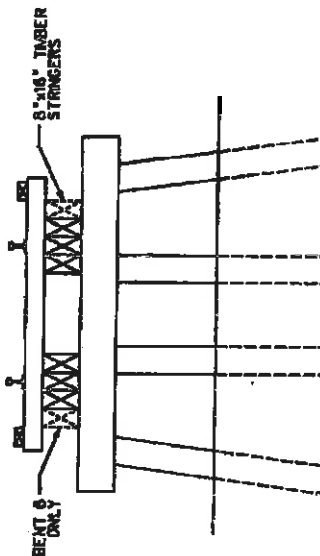

TIMBER PILE
BENTS 1 & 6

BRIDGE INSPECTION REPORT

APRIL 13, 2017

BRIDGE NO. SBVR-37.4

PLAN & ELEVATION

PAGE: 2 OF 3

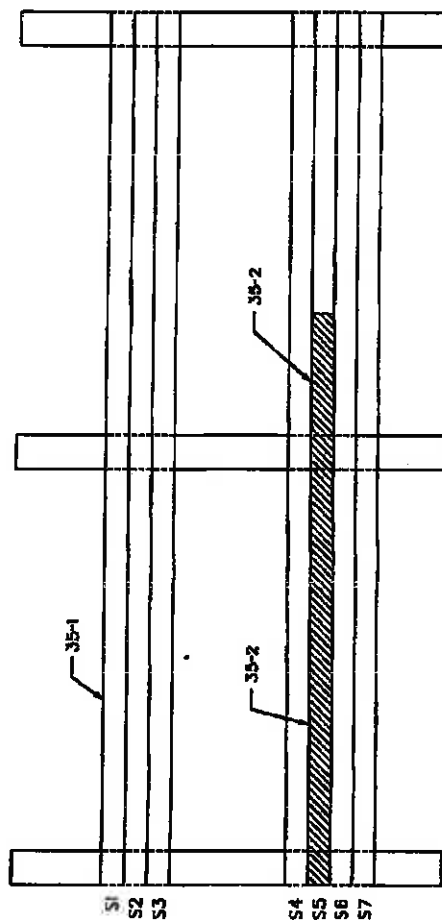
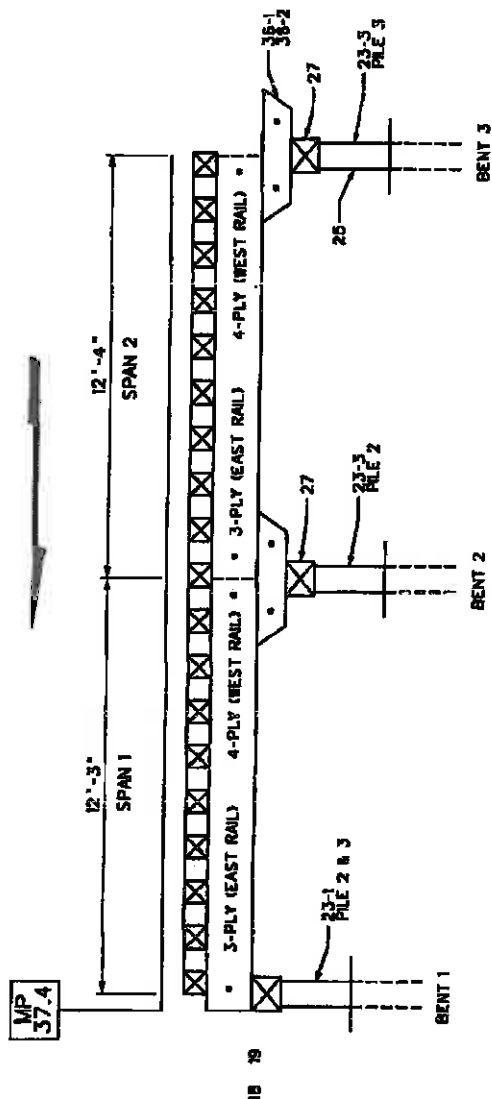

BRIDGE INSPECTION REPORT

APRIL 13, 2017

BRIDGE NO. SBYR-37.4

PLAN & ELEVATION

PAGE: 3 OF 3

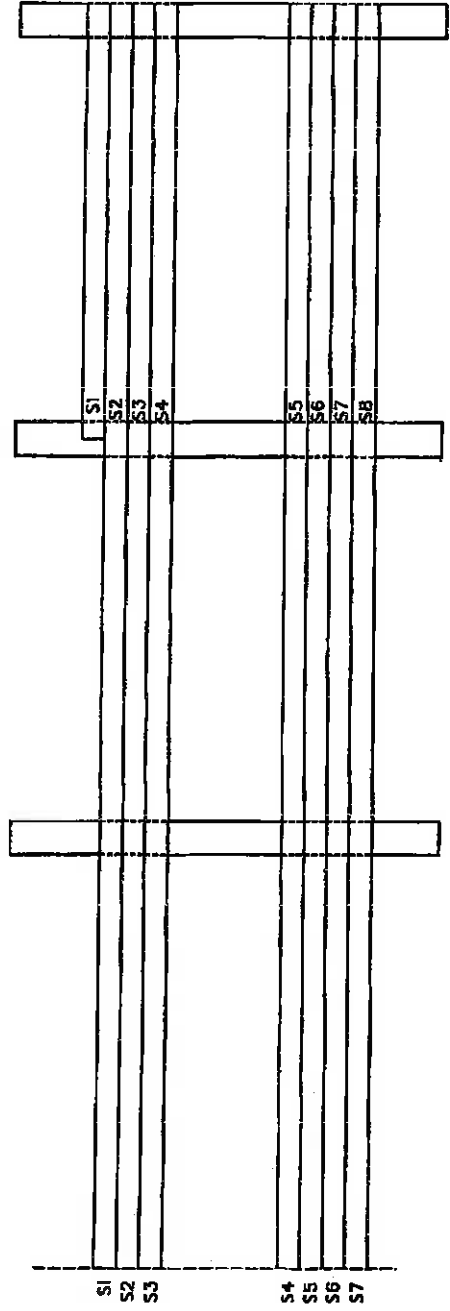
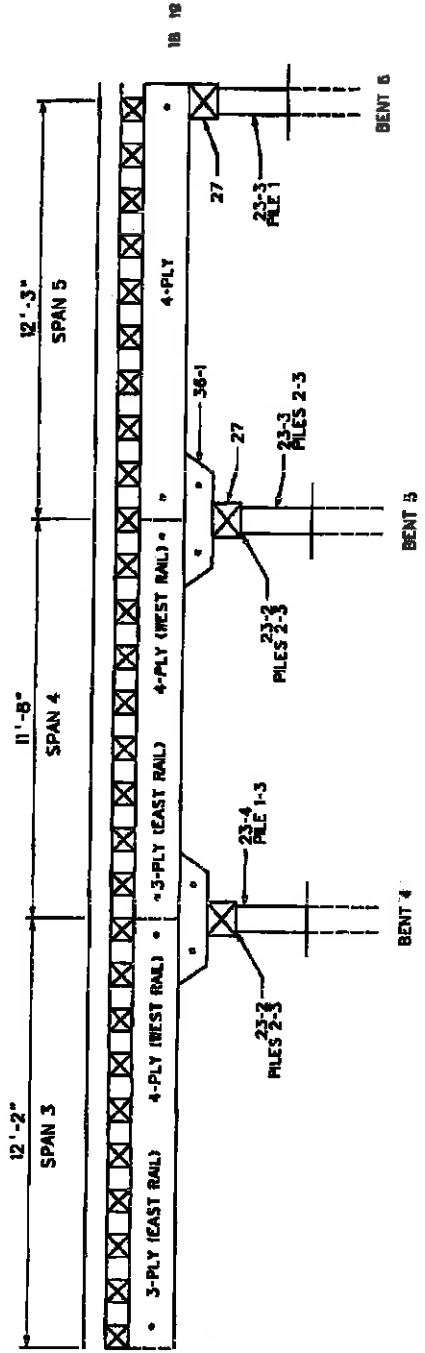

BRIDGE INSPECTION REPORT

APRIL 20, 2017

BRIDGE NO. SBVR-43.8

TYPICAL SECTION VIEW

PAGE: 1

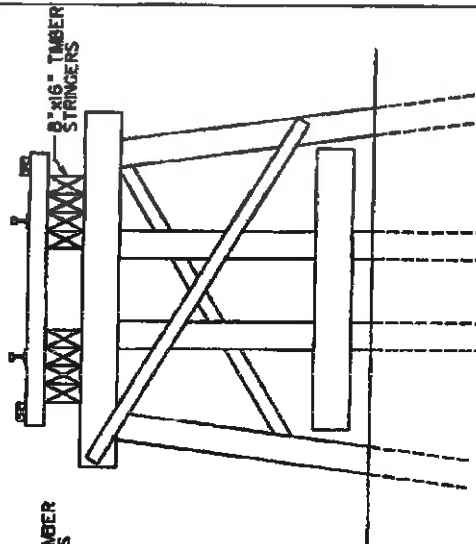

TIMBER FRAME/
PILE BENT 5

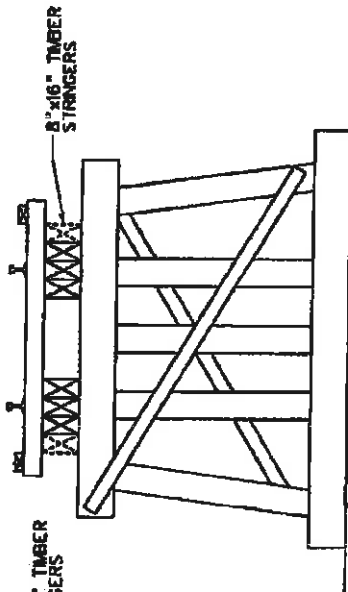

TIMBER FRAME
BENT 4

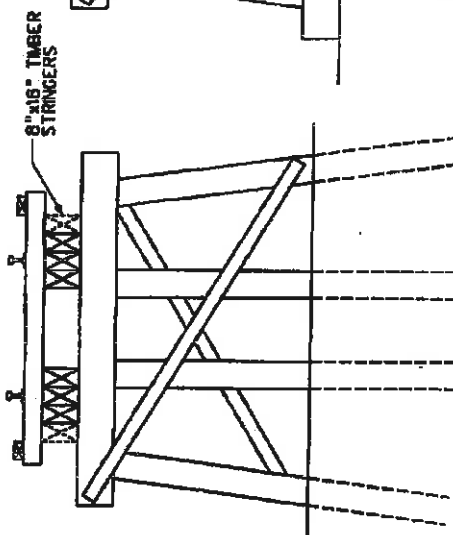

TIMBER PILE
BENTS 1-3 & 6-8

BRIDGE INSPECTION REPORT

APRIL 20, 2017

BRIDGE NO. SBVR-43.8

PLAN & ELEVATION

PAGE: 2

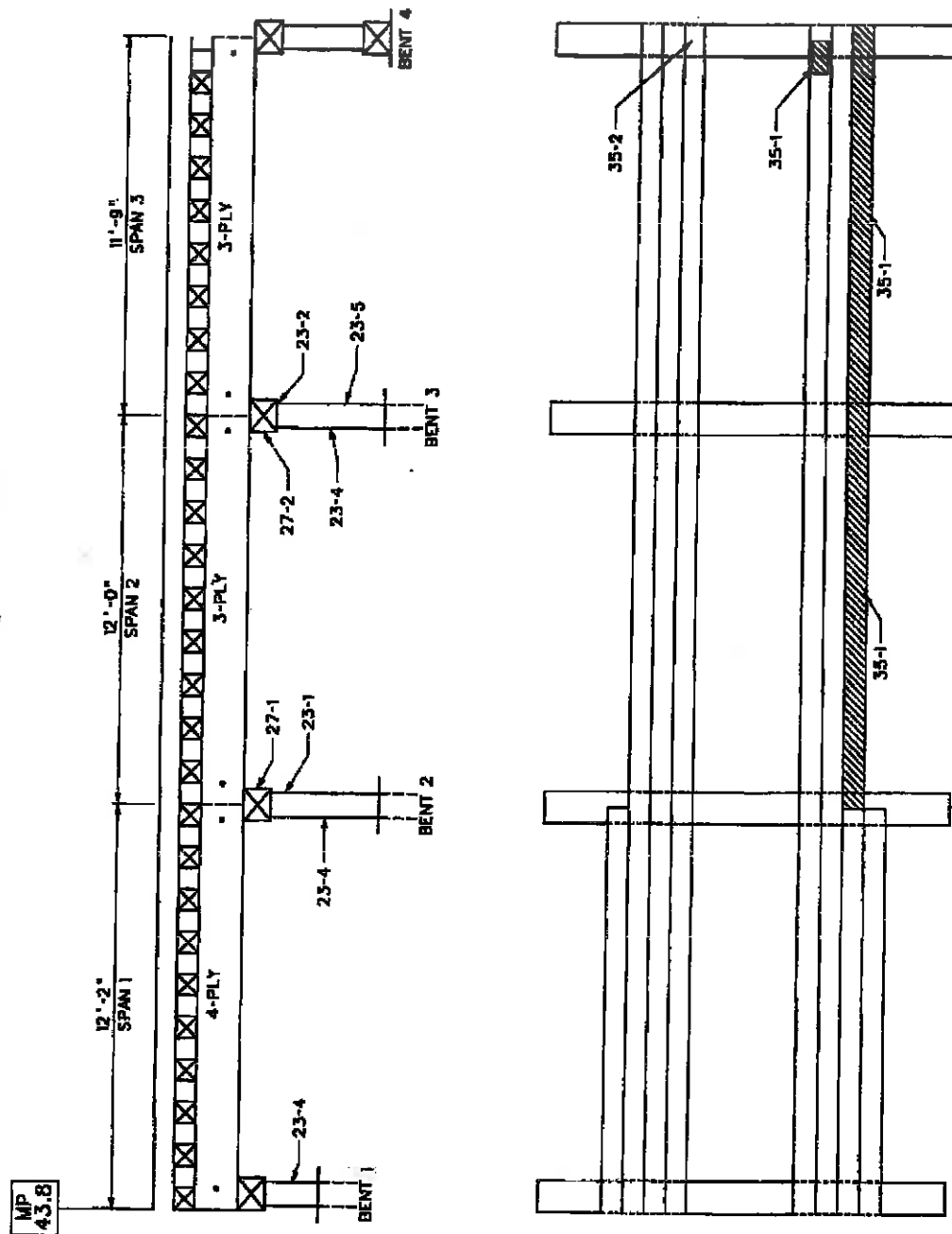

BRIDGE INSPECTION REPORT

APRIL 20, 2017

BRIDGE NO. SBVR-43.8

PLAN & ELEVATION

PAGE: 3

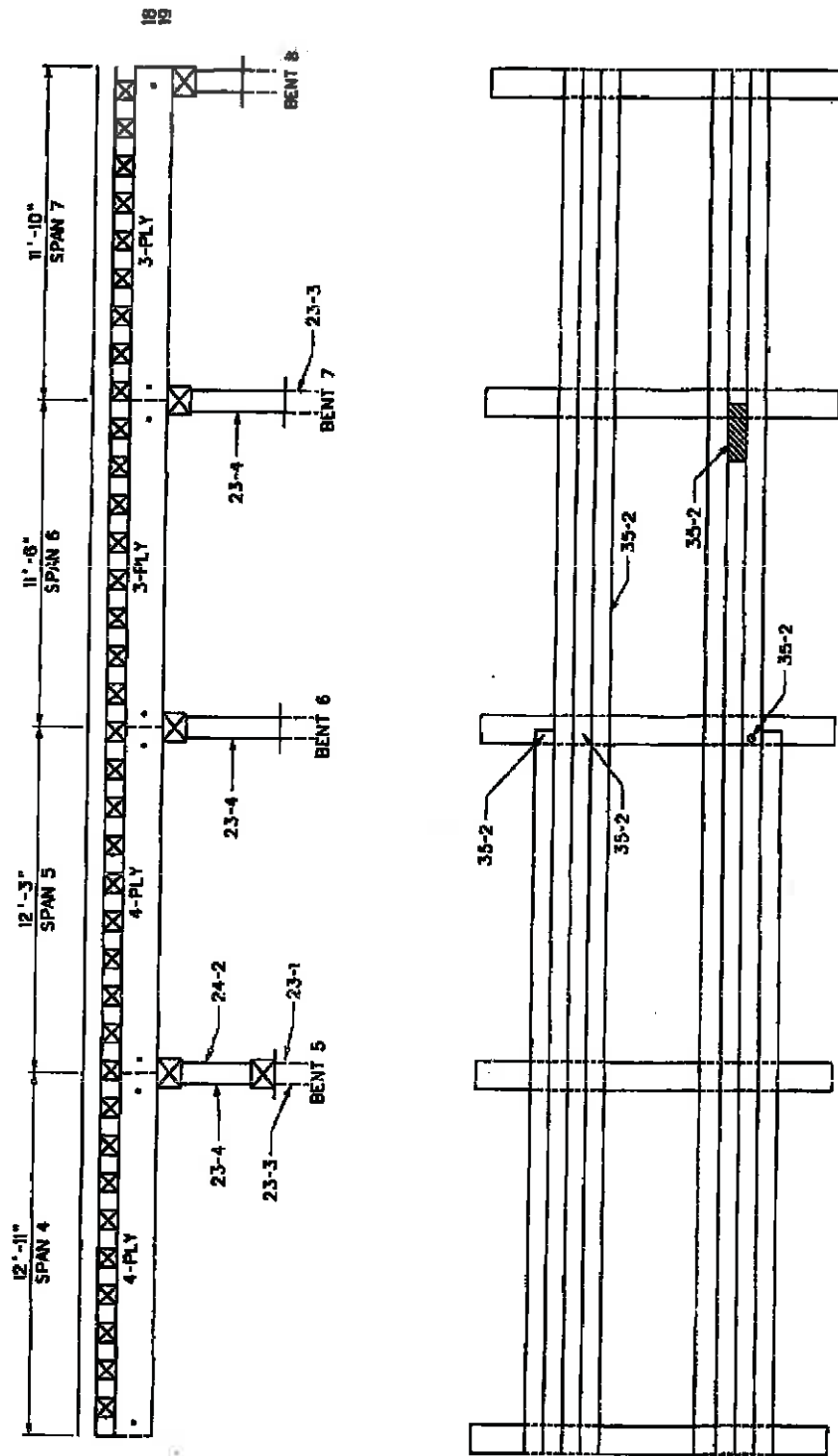

Notes

Cost for excavation, removal and disposal of material necessary in construction of gabion retaining walls shall be included in cost for Item 24000-000, 13.1.5.1
All unsuitable material shall be removed and disposed of in an approved waste site.
No separate payment will be made for this work.

Attachment "B"

Tributary to South Branch of Potomac River

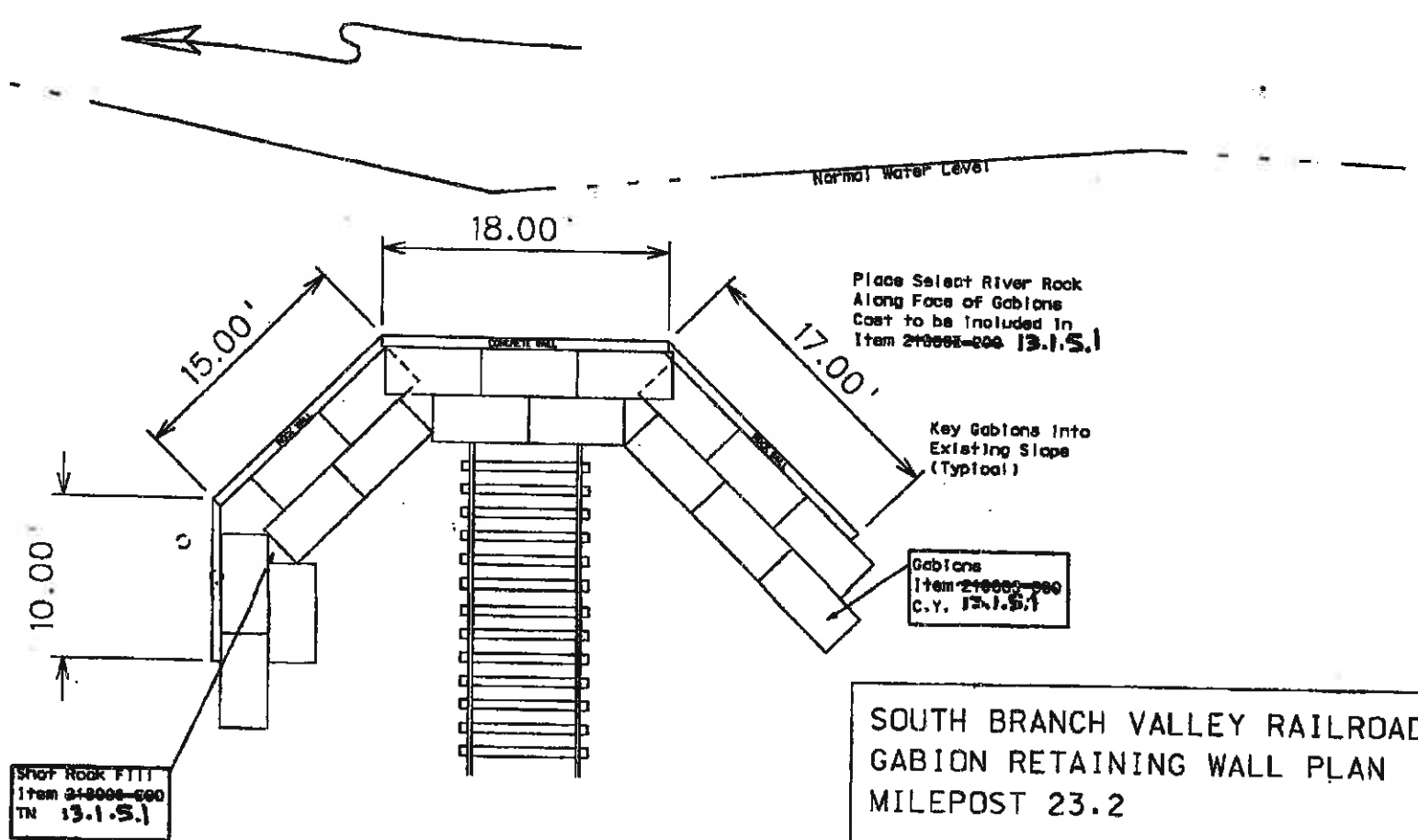

Place Select River Rock Along Face of Gabions
Cost to be included in
Item 24000-000 13.1.5.1

Key Gabions into Existing Slope
(Typical)

Gabions
Item 24000-000
C.Y. 13.1.5.1

Shot Rock FILL
Item 24000-000
TN 13.1.5.1

SOUTH BRANCH VALLEY RAILROAD
GABION RETAINING WALL PLAN
MILEPOST 23.2

PLAN
Not to Scale

HAMPSHIRE COUNTY

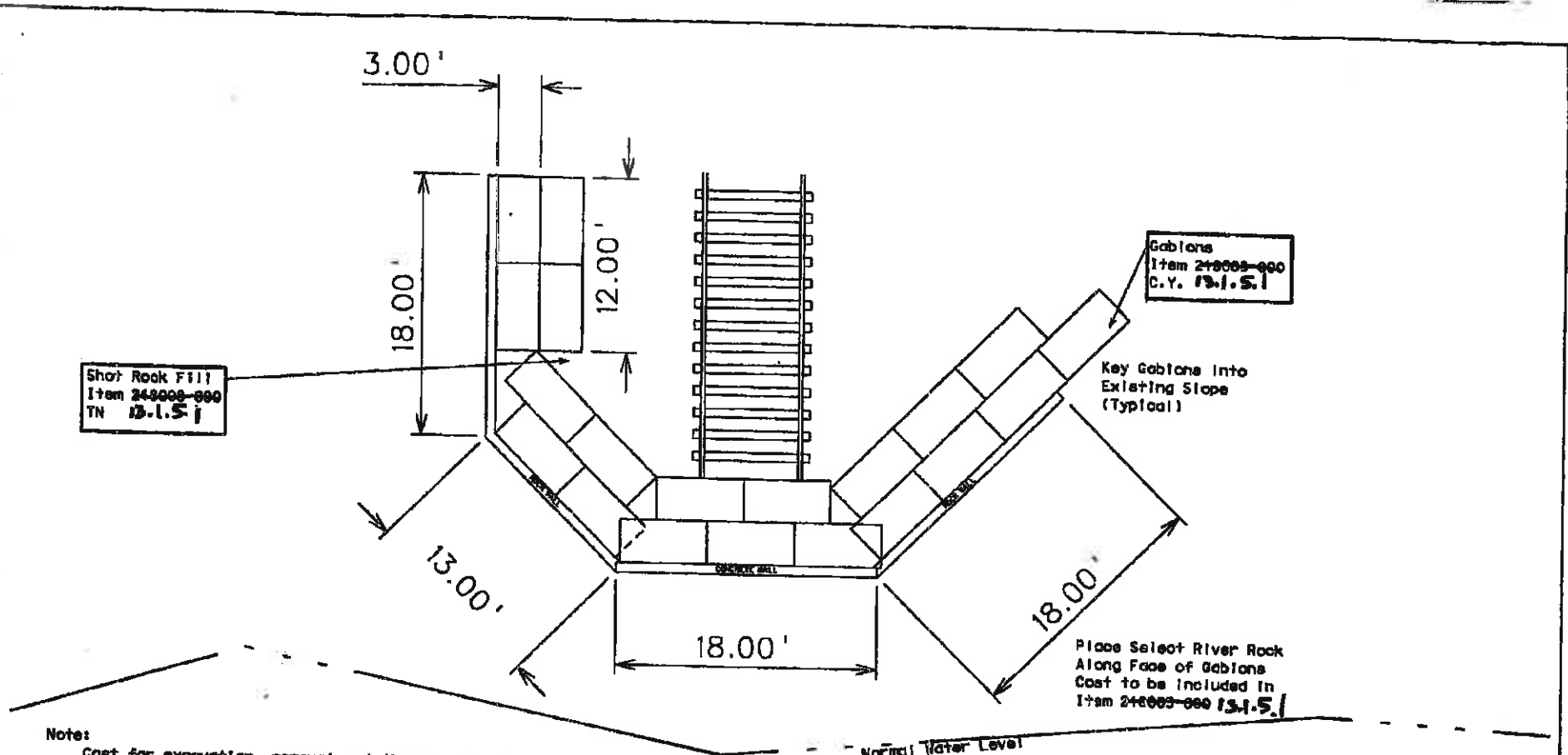

Note:

Cost for excavation, removal and disposal of material necessary in construction of gabion retaining walls shall be included in cost for item 24000-000 I.S.I. All unsuitable material shall be removed and disposed of in an approved waste site. No separate payment will be made for this work.

PLAN
Not to Scale

Tributary to South Branch of Potomac River



SOUTH BRANCH VALLEY RAILROAD
GABION RETAINING WALL PLAN
MILEPOST 23.2

HAMPSHIRE COUNTY

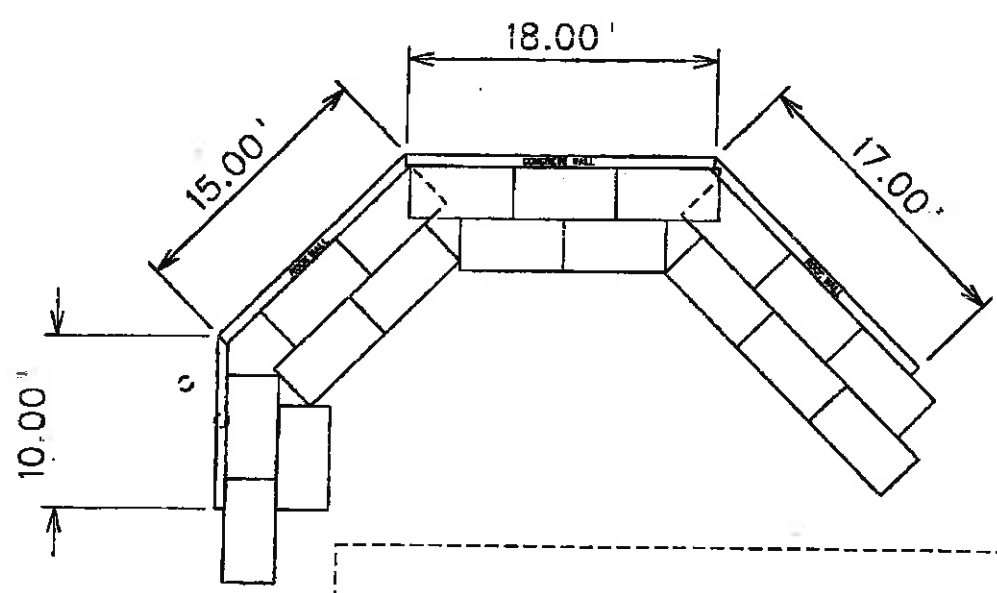
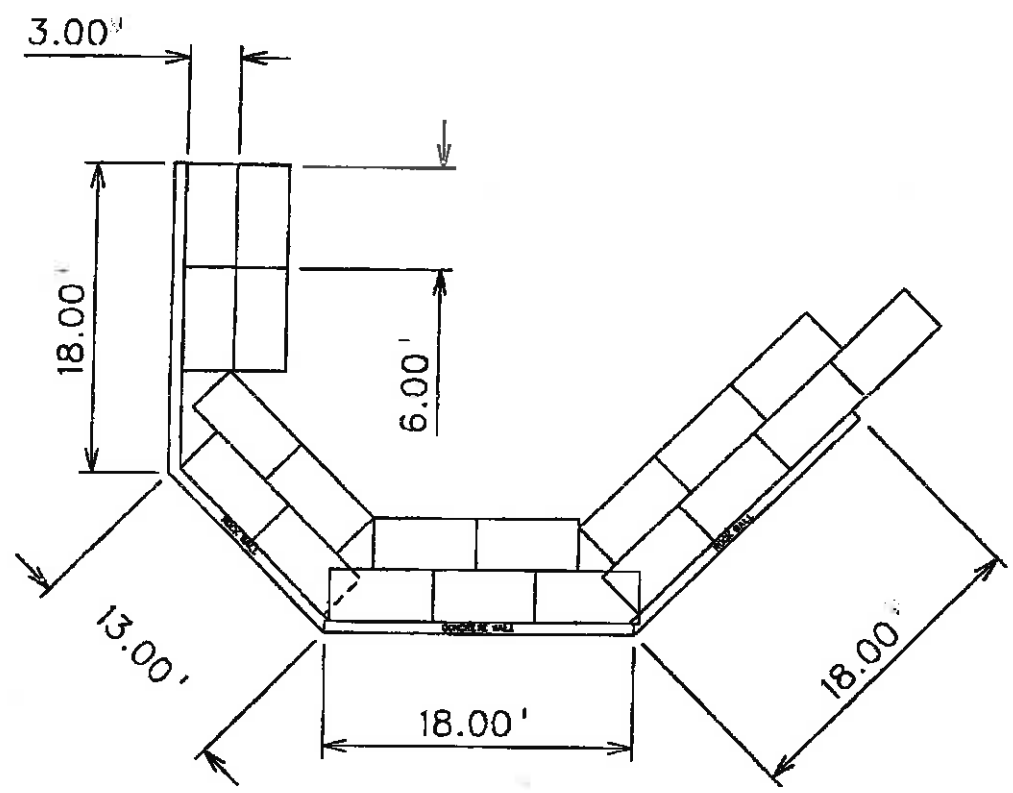

SBVRR BRIDGE 23.2
TYPICALS

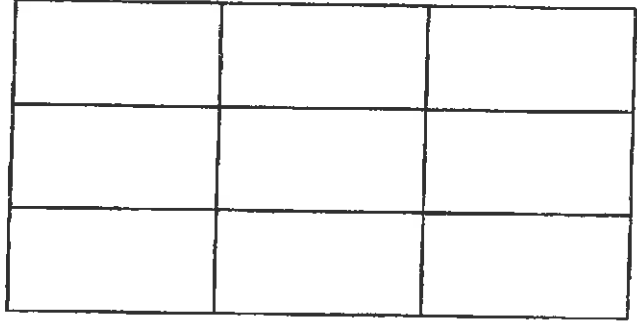
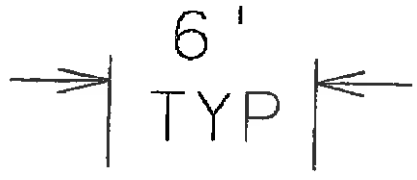

WING WALL

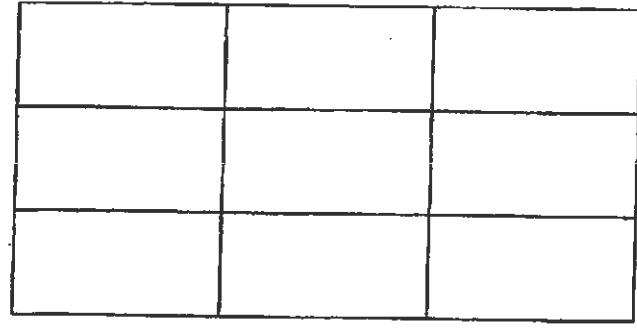
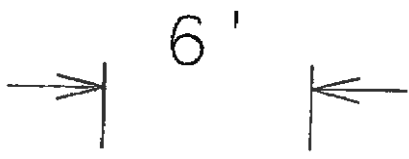

BREAST WALL

SBVRR BRIDGE 23.2
TYPICALS

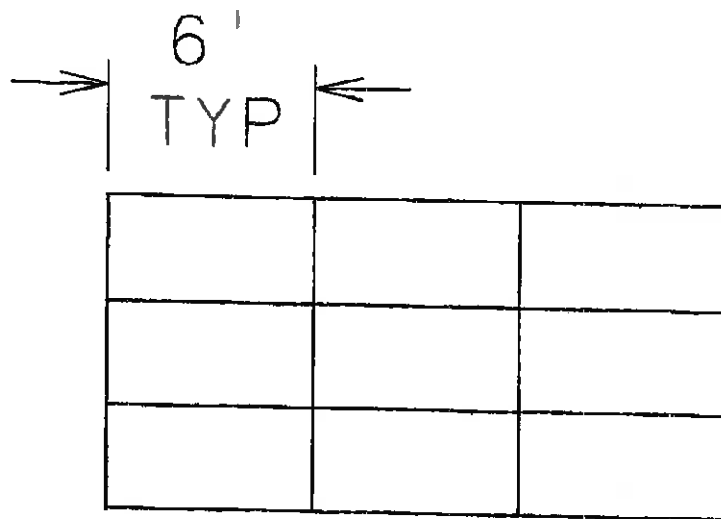

WING WALL

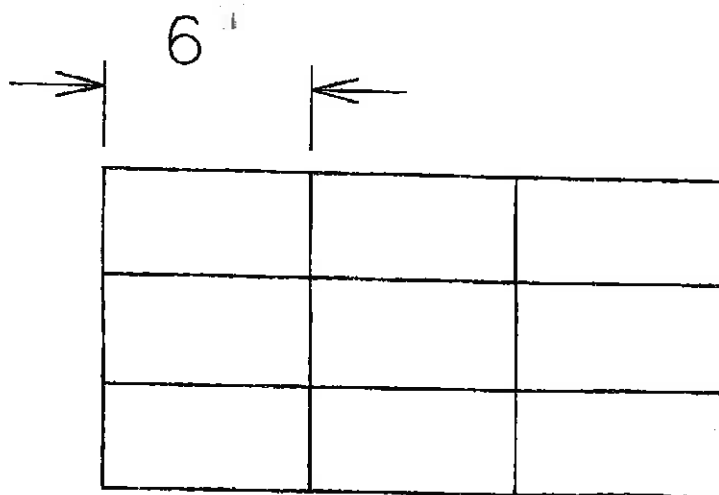

BREAST WALL

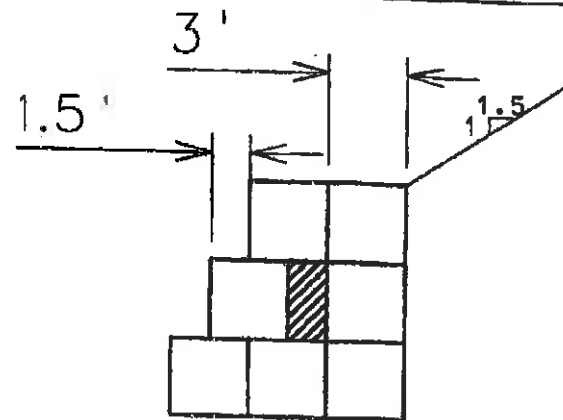

TYPICAL SECTION

SECTIONS SHOWN HATCHED DO NOT
REQUIRE GABION MESH UNLESS THEY
ARE IN THE BOTTOM COURSE OF THE
WALL



THE COST FOR ALL LABOR, MATERIALS, AND EQUIPMENT NECESSARY TO
CONSTRUCT THE GABIONS IN ACCORDANCE WITH THE ATTACHED DETAIL
SHALL BE INCLUDED IN THE UNIT BID PRICE OF ITEM ~~210003-000~~
13-1.5.1

SOUTH BRANCH VALLEY RAILROAD.
GABION RETAINING WALL PLAN
MILEPOST 23.2

HAMPSHIRE COUNTY

STATE OF WEST VIRGINIA
Purchasing Division

PURCHASING AFFIDAVIT

CONSTRUCTION CONTRACTS: Under W. Va. Code § 5-22-1(i), the contracting public entity shall not award a construction contract to any bidder that is known to be in default on any monetary obligation owed to the state or a political subdivision of the state, including, but not limited to, obligations related to payroll taxes, property taxes, sales and use taxes, fire service fees, or other fines or fees.

ALL CONTRACTS: Under W. Va. Code §5A-3-10a, no contract or renewal of any contract may be awarded by the state or any of its political subdivisions to any vendor or prospective vendor when the vendor or prospective vendor or a related party to the vendor or prospective vendor is a debtor and: (1) the debt owed is an amount greater than one thousand dollars in the aggregate; or (2) the debtor is in employer default.

EXCEPTION: The prohibition listed above does not apply where a vendor has contested any tax administered pursuant to chapter eleven of the W. Va. Code, workers' compensation premium, permit fee or environmental fee or assessment and the matter has not become final or where the vendor has entered into a payment plan or agreement and the vendor is not in default of any of the provisions of such plan or agreement.

DEFINITIONS:

"Debt" means any assessment, premium, penalty, fine, tax or other amount of money owed to the state or any of its political subdivisions because of a judgment, fine, permit violation, license assessment, defaulted workers' compensation premium, penalty or other assessment presently delinquent or due and required to be paid to the state or any of its political subdivisions, including any interest or additional penalties accrued thereon.

"Employer default" means having an outstanding balance or liability to the old fund or to the uninsured employers' fund or being in policy default, as defined in W. Va. Code § 23-2c-2, failure to maintain mandatory workers' compensation coverage, or failure to fully meet its obligations as a workers' compensation self-insured employer. An employer is not in employer default if it has entered into a repayment agreement with the insurance Commissioner and remains in compliance with the obligations under the repayment agreement.

"Related party" means a party, whether an individual, corporation, partnership, association, limited liability company or any other form or business association or other entity whatsoever, related to any vendor by blood, marriage, ownership or contract through which the party has a relationship of ownership or other interest with the vendor so that the party will actually or by effect receive or control a portion of the benefit, profit or other consideration from performance of a vendor contract with the party receiving an amount that meets or exceeds five percent of the total contract amount.

AFFIRMATION: By signing this form, the vendor's authorized signer affirms and acknowledges under penalty of law for false swearing (W. Va. Code §61-5-3) that: (1) for construction contracts, the vendor is not in default on any monetary obligation owed to the state or a political subdivision of the state, and (2) for all other contracts, that neither vendor nor any related party owe a debt as defined above and that neither vendor nor any related party are in employer default as defined above, unless the debt or employer default is permitted under the exception above.

WITNESS THE FOLLOWING SIGNATURE:

Vendor's Name: Gregori Construction Inc.

Authorized Signature: [Signature]

Date: 6/11/18

State of PENNSYLVANIA

County of BUTLER, to-wit

Taken, subscribed, and sworn to before me this 11th day of JUNE, 2018.

My Commission expires JULY 14, 2021.

AFFIX SEAL HERE

NOTARY PUBLIC

COMMONWEALTH OF PENNSYLVANIA
NOTARIAL SEAL
Gary L. McKissick, Notary Public
Neshannock Twp., Lawrence County
My Commission Expires July 14, 2021
MEMBER, PENNSYLVANIA ASSOCIATION OF NOTARIES

[Signature]
Purchasing Affidavit (Revised 01/19/2018)

West Virginia Ethics Commission



Disclosure of Interested Parties to Contracts

Pursuant to *W. Va. Code* § 6D-1-2, a state agency may not enter into a contract, or a series of related contracts, that has/have an actual or estimated value of \$100,000 or more until the business entity submits to the contracting state agency a Disclosure of Interested Parties to the applicable contract. In addition, the business entity awarded a contract is obligated to submit a supplemental Disclosure of Interested Parties reflecting any new or differing interested parties to the contract within 30 days following the completion or termination of the applicable contract.

For purposes of complying with these requirements, the following definitions apply:

"Business entity" means any entity recognized by law through which business is conducted, including a sole proprietorship, partnership or corporation.

"Interested party" or "Interested parties" means:

- (1) A business entity performing work or service pursuant to, or in furtherance of, the applicable contract, including specifically sub-contractors;
- (2) the person(s) who have an ownership interest equal to or greater than 25% in the business entity performing work or service pursuant to, or in furtherance of, the applicable contract. (This subdivision does not apply to a publicly traded company); and
- (3) the person or business entity, if any, that served as a compensated broker or intermediary to actively facilitate the applicable contract or negotiated the terms of the applicable contract with the state agency. (This subdivision does not apply to persons or business entities performing legal services related to the negotiation or drafting of the applicable contract.)

"State agency" means a board, commission, office, department or other agency in the executive, judicial or legislative branch of state government, including publicly funded institutions of higher education: Provided, that for purposes of *W. Va. Code* § 6D-1-2, the West Virginia Investment Management Board shall not be deemed a state agency nor subject to the requirements of that provision.

The contracting business entity must complete this form and submit it to the contracting state agency prior to contract award and to complete another form within 30 days of contract completion or termination.

This form was created by the State of West Virginia Ethics Commission, 210 Brooks Street, Suite 300, Charleston, WV 25301-1804. Telephone: (304)558-0664; fax: (304)558-2169; e-mail: ethics@wv.gov; website: www.ethics.wv.gov

West Virginia Ethics Commission
Disclosure of Interested Parties to Contracts

(Required by W. Va. Code § 6D-1-2)

Contracting Business Entity: Gregori Construction Inc. Address: P.O. Box 121, 736 Ekastown Rd
Scraper, Pa 16055

Authorized Agent: STATE RAIL Authority (DBA)
South Branch Valley Railroad Address: 120 Water Plant Dr. Moorefield, WV 26036

Contract Number: CRFQ 0804 RMA 180000007 Contract Description: Bridge Repair

Governmental agency awarding contract: Purchasing Division, State of West Virginia

Check here if this is a Supplemental Disclosure

List the Names of Interested Parties to the contract which are known or reasonably anticipated by the contracting business entity for each category below (attach additional pages if necessary):

1. Subcontractors or other entities performing work or service under the Contract

Check here if none, otherwise list entity/individual names below.

Amtrak Railroad Contractors of Maryland, Inc.

2. Any person or entity who owns 25% or more of contracting entity (not applicable to publicly traded entities)

Check here if none, otherwise list entity/individual names below.

Richard Gregori

3. Any person or entity that facilitated, or negotiated the terms of, the applicable contract (excluding legal services related to the negotiation or drafting of the applicable contract)

Check here if none, otherwise list entity/individual names below.

Signature: Anthony Lascola Date Signed: 6/11/18

Notary Verification

State of PENNSYLVANIA, County of BUTLER

I, ANTHONY LASCOLA, the authorized agent of the contracting business entity listed above, being duly sworn, acknowledge that the Disclosure herein is being made under oath and under the penalty of perjury.

Taken, sworn to and subscribed before me this 11th day of JUNE, 2018

Gary L. McKissick
Notary Public's Signature

To be completed by State Agency:

Date Received by State Agency: _____
Date submitted to Ethics Commission: _____
Governmental agency submitting Disclosure: _____

COMMONWEALTH OF PENNSYLVANIA
NOTARIAL SEAL
Gary L. McKissick, Notary Public
Neshannock Twp., Lawrence County
My Commission Expires July 14, 2021
MEMBER, PENNSYLVANIA ASSOCIATION OF NOTARIES

Revised October 7, 2017



State of West Virginia
DRUG FREE WORKPLACE CONFORMANCE AFFIDAVIT
West Virginia Code §21-1D-5

~~STATE OF WEST VIRGINIA,~~
~~COUNTY OF Hampshire,~~ TO-WIT:
PENNSYLVANIA
BUTLER

I, Anthony Lascola, after being first duly sworn, depose and state as follows:

- 1. I am an employee of Gregori Construction Inc.; and,
(Company Name)
- 2. I do hereby attest that Gregori Construction Inc.
(Company Name)

maintains a written plan for a drug-free workplace policy and that such plan and policy are in compliance with **West Virginia Code** §21-1D.

The above statements are sworn to under the penalty of perjury.

Printed Name: Anthony Lascola
 Signature: *Anthony Lascola*
 Title: U.P.
 Company Name: Gregori Construction Inc.
 Date: 6/11/18

Taken, subscribed and sworn to before me this 11th day of June, 2018.

By Commission expires 7/14/21

(Seal)

Gary L. McKissick
 (Notary Public)

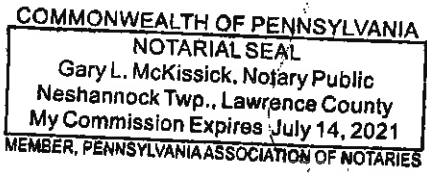

BID BOND

KNOW ALL MEN BY THESE PRESENTS, That we, the undersigned, Gregori Construction Inc.
of Sarver , PA , as Principal, and Great American Insurance Company
of Cincinnati , OH , a corporation organized and existing under the laws of the State of
OH with its principal office in the City of Cincinnati , as Surety, are held and firmly bound unto the State
of West Virginia, as Obligee, in the penal sum of Five Percent of Amount Bid (\$ 5%) for the payment of which,
well and truly to be made, we jointly and severally bind ourselves, our heirs, administrators, executors, successors and assigns.

The Condition of the above obligation is such that whereas the Principal has submitted to the Purchasing Section of the
Department of Administration a certain bid or proposal, attached hereto and made a part hereof, to enter into a contract in writing for
Repair of 7 Bridges on South Branch Valley Railroad, Timber Repairs and Bridge Replacement; #CRFQ 0804
RMA18*7

NOW THEREFORE,

- (a) If said bid shall be rejected, or
- (b) If said bid shall be accepted and the Principal shall enter into a contract in accordance with the bid or proposal
attached hereto and shall furnish any other bonds and insurance required by the bid or proposal, and shall in all other respects perform
the agreement created by the acceptance of said bid, then this obligation shall be null and void, otherwise this obligation shall remain in
full force and effect. It is expressly understood and agreed that the liability of the Surety for any and all claims hereunder shall, in no
event, exceed the penal amount of this obligation as herein stated.

The Surety, for the value received, hereby stipulates and agrees that the obligations of said Surety and its bond shall be in no
way impaired or affected by any extension of the time within which the Obligee may accept such bid, and said Surety does hereby
waive notice of any such extension.

WITNESS, the following signatures and seals of Principal and Surety, executed and sealed by a proper officer of Principal and
Surety, or by Principal individually if Principal is an individual, this 13th day of June, 2018

Principal Seal

Gregori Construction Inc.
(Name of Principal)
By: Anth. J. Anthony Lascol
(Must be President, Vice President, or
Duly Authorized Agent)
U.P.
(Title)

Surety Seal



Great American Insurance Company
(Name of Surety)
By: Josephine M. Streyle
Josephine M. Streyle Attorney-in-Fact

IMPORTANT – Surety executing bonds must be licensed in West Virginia to transact surety insurance, must affix its seal, and must attach a power of attorney with its seal affixed.

GREAT AMERICAN INSURANCE COMPANY®

Administrative Office: 301 E 4TH STREET • CINCINNATI, OHIO 45202 • 513-369-5000 • FAX 513-723-2740

The number of persons authorized by this power of attorney is not more than 1

Bond No. Bid Bond

POWER OF ATTORNEY

KNOW ALL MEN BY THESE PRESENTS: That the GREAT AMERICAN INSURANCE COMPANY, a corporation organized and existing under and by virtue of the laws of the State of Ohio, does hereby nominate, constitute and appoint the person or persons named below its true and lawful attorney-in-fact, for it and in its name, place and stead to execute on behalf of the said Company, as surety, the specific bond, undertaking or contract of suretyship referenced herein; provided that the liability of the said Company on any such bond, undertaking or contract of suretyship executed under this authority shall not exceed the limit stated below. The bond number on this Power of Attorney must match the bond number on the bond to which it is attached or it is invalid.

Name	Address	Limit of Power
Josephine M. Streyle	225 North Shore Drive, Suite 300 Pittsburgh, PA 15212	\$100,000,000.00

Principal: Gregori Construction Inc.
Obligee: State of West Virginia

IN WITNESS WHEREOF the GREAT AMERICAN INSURANCE COMPANY has caused these presents to be signed and attested by its appropriate officers and its corporate seal hereunto affixed this 13th day of June, 2018.

Attest

GREAT AMERICAN INSURANCE COMPANY



Atty L C. B.
Assistant Secretary

David C. Kitchin
Divisional Senior Vice President

DAVID C. KITCHIN (877-377-2405)

STATE OF OHIO, COUNTY OF HAMILTON - ss:

On this 13th day of June, 2018, before me personally appeared DAVID C. KITCHIN, to me known, being duly sworn, deposes and says that he resides in Cincinnati, Ohio, that he is a Divisional Senior Vice President of the Bond Division of Great American Insurance Company, the Company described in and which executed the above instrument; that he knows the seal of the said Company; that the seal affixed to the said instrument is such corporate seal; that it was so affixed by authority of his office under the By-Laws of said Company, and that he signed his name thereto by like authority.



Susan A. Kohorst
Notary Public, State of Ohio
My Commission Expires 05-18-2020

Susan A. Kohorst

This Power of Attorney is granted by authority of the following resolutions adopted by the Board of Directors of Great American Insurance Company by unanimous written consent dated June 9, 2008.

RESOLVED: That the Divisional President, the several Divisional Senior Vice Presidents, Divisional Vice Presidents and Divisional Assistant Vice Presidents, or any one of them, be and hereby is authorized, from time to time, to appoint one or more Attorneys-in-Fact to execute on behalf of the Company, as surety, any and all bonds, undertakings and contracts of suretyship, or other written obligations in the nature thereof; to prescribe their respective duties and the respective limits of their authority; and to revoke any such appointment at any time.

RESOLVED FURTHER: That the Company seal and the signature of any of the aforesaid officers and any Secretary or Assistant Secretary of the Company may be affixed by facsimile to any power of attorney or certificate of either given for the execution of any bond, undertaking, contract of suretyship, or other written obligation in the nature thereof, such signature and seal when so used being hereby adopted by the Company as the original signature of such officer and the original seal of the Company, to be valid and binding upon the Company with the same force and effect as though manually affixed.

CERTIFICATION

I, STEPHEN C. BERAHA, Assistant Secretary of Great American Insurance Company, do hereby certify that the foregoing Power of Attorney and the Resolutions of the Board of Directors of June 9, 2008 have not been revoked and are now in full force and effect.

Signed and sealed this 13th day of June, 2018.



Atty L C. B.
Assistant Secretary

BID BOND PREPARATION INSTRUCTIONS

AGENCY (A) _____
RFQ/RFP# (B) _____

- (A) WV State Agency
(Stated on Page 1 "Spending Unit")
- (B) Request for Quotation Number (upper right corner of page #1)
- (C) Your Business Entity Name (or Individual Name if Sole Proprietor)
- (D) City, Location of your Company
- (E) State, Location of your Company
- (F) Surety Corporate Name
- (G) City, Location of Surety
- (H) State, Location of Surety
- (I) State of Surety Incorporation
- (J) City of Surety's Principal Office
- (K) Minimum amount of acceptable bid bond is 5% of total bid. You may state "5% of bid" or a specific amount on this line in words.
- (L) Amount of bond in numbers
- (M) Brief Description of scope of work
- (N) Day of the month
- (O) Month
- (P) Year
- (Q) Name of Business Entity (or Individual Name if Sole Proprietor)
- (R) Seal of Principal
- (S) Signature of President, Vice President, or Authorized Agent
- (T) Title of Person Signing for Principal
- (U) Seal of Surety
- (V) Name of Surety
- (W) Signature of Attorney in Fact of the Surety

Bid Bond
KNOW ALL MEN BY THESE PRESENTS, That we, the undersigned,
_____(C)_____ of _____(D)_____ _____(E)_____
as Principal, and _____(F)_____ of _____(G)_____
_____(H)_____, a corporation organized and existing under the laws
of the State of _____(I)_____ with its principal office in the City of
_____(J)_____, as Surety, are held and firmly bound unto The State
of West Virginia, as Obligee, in the penal sum of _____(K)_____
(\$ _____(L)_____) for the payment of which, well and truly to be made,
we jointly and severally bind ourselves, our heirs, administrators, executors,
successors and assigns.

The Condition of the above obligation is such that whereas the Principal has submitted to the Purchasing Section of the Department of Administration a certain bid or proposal, attached hereto and made a part hereof to enter into a contract in writing for _____
_____(M)_____

NOW THEREFORE

- (a) If said bid shall be rejected, or
- (b) If said bid shall be accepted and the Principal shall enter into a contract in accordance with the bid or proposal attached hereto and shall furnish any other bonds and insurance required by the bid or proposal, and shall in all other respects perform the agreement created by the acceptance of said bid then this obligation shall be null and void, otherwise this obligation shall remain in full force and effect. It is expressly understood and agreed that the liability of the Surety for any and all claims hereunder shall, in no event, exceed the penal amount of this obligation as herein stated

The Surety for value received, hereby stipulates and agrees that the obligations of said Surety and its bond shall be in no way impaired or affected by any extension of time within which the Obligee may accept such bid: and said Surety does hereby waive notice of any such extension.

WITNESS, the following signatures and seals of Principal and Surety, executed and sealed by a proper officer of Principal and Surety, or by Principal individually if Principal is an individual, the _____(N)_____ day of _____(O)_____, 20_____(P)_____.

Principal Seal _____(Q)_____
(Name of Principal)
(R)
By _____(S)_____
(Must be President, Vice President, or Duly Authorized Agent)
_____(T)_____
Title
Surety Seal _____(U)_____
(Name of Surety)
_____(V)_____
Attorney-in-Fact

NOTE 1: Dated Power of Attorney with Surety Seal must accompany this bid bond.

IMPORTANT – Surety executing bonds must be licensed in West Virginia to transact surety insurance, must affix its seal, and must attach a power of attorney with its seal affixed.

State of West Virginia
Purchasing Division

CERTIFIED DRUG-FREE WORKPLACE REPORT COVERSHEET

In accordance with *West Virginia Code* § 21-1D-7b, no less than once per year, or upon completion of the project, every contractor shall provide a certified report to the public authority which let the contract. That report must include each of the items identified below in the Required Report Content section.

Instructions: Vendor should complete this coversheet, attach it to the required report, and submit it to the appropriate location as follows: For contracts more than \$25,000, the report should be mailed to the West Virginia Purchasing Division at 2019 Washington Street East, Charleston, WV 25305. For contracts of \$25,000 or less, the vendor should mail the report to the public authority issuing the contract.

Contract Identification:

Contract Number: CRFQ 0804 RMA1800000007

Contract Purpose: Bridge Rehabilitation

Agency Requesting Work: Purchasing Division, State of West Virginia

Required Report Content: The attached report must include each of the items listed below. The vendor should check each box as an indication that the required information has been included in the attached report.

To BE
Provided
upon
AWARD

- Information indicating the education and training service to the requirements of *West Virginia Code* § 21-1D-5 was provided;
- Name of the laboratory certified by the United States Department of Health and Human Services or its successor that performs the drug tests;
- Average number of employees in connection with the construction on the public improvement;
- Drug test results for the following categories including the number of positive tests and the number of negative tests: (A) Pre-employment and new hires; (B) Reasonable suspicion; (C) Post-accident; and (D) Random.

Vendor Contact Information:

Vendor Name: Gregori Construction Inc.

Vendor Telephone: 724-353-1322

Vendor Address: P.O. Box 121, 736 Ekastun Rd
Sevier, Pa 16055

Vendor Fax: 724-353-2486

Vendor E-Mail: Cserafino@gregori-inc.com



State of West Virginia

PURCHASING DIVISION

Construction Bid Submission Review Form

This list has been provided for informational purposes only and is not to be construed as a complete list of request for quotation or bidding requirements for any individual construction project. This list does not and cannot include every item, mistake or oversight that could cause a contractor's bid to be disqualified. Rather, this list is intended to draw attention to some of the most common problems that the Purchasing Division encounters in the bidding process for construction projects. All potential bidders must read the request for quotation, all additional documents, and all instructions relating thereto ("Bid Documents") in their entirety to identify the actual request for quotation and bidding requirements. Failure to read the Bid Documents in their entirety and comply with the stated requirements contained therein may result in bid disqualification.

Errors That Shall Be Reason for Immediate Bid Disqualification

1. Failure to attend a mandatory pre-bid meeting
2. Failure to sign the bid
3. Failure to supply a valid bid bond or other surety approved by the State of West Virginia
4. Failure to meet any mandatory requirement of the RFQ
5. Failure to acknowledge receipt of Addenda (only if stipulated as mandatory)
6. Failure to submit bid prior to the bid opening date and time
7. Federal debarment
8. State of West Virginia debarment or suspension

Errors that May Be Reason for Bid Disqualification Before Contract Award

1. Debt to the State or Political Subdivision (must be cured prior to award)
2. Workers' Compensation or Unemployment Compensation delinquency (must be cured prior to award)
3. Not registered as a vendor with the State (must be cured prior to award)
4. Failure to obtain required bonds and/or insurance
5. Failure to provide the sub-contractor listing within one business day of bid opening or one business day of the request to do so by the Purchasing Division.
6. Failure to supply West Virginia contractor's license number with bid or within one day of Purchasing Division request to do so.
7. Failure to supply a signed drug free workplace affidavit with bid or within one day of Purchasing Division request to do so.
8. Failure to use the provided RFQ form (only if stipulated as mandatory).