



Purchasing Division  
 2019 Washington Street East  
 Post Office Box 50130  
 Charleston, WV 25305-0130

State of West Virginia  
 Request for Quotation  
 19 — Highways

Proc Folder: 432815

Doc Description: FLAT SHEET AND PRE-CUT ALUMINUM

Proc Type: Central Master Agreement

Date Issued	Solicitation Closes	Solicitation No	Version
2018-04-05	2018-04-26 13:30:00	CRFQ 0803 DOT1800000085	1

**BID RECEIVING LOCATION**

BID CLERK  
 DEPARTMENT OF ADMINISTRATION  
 PURCHASING DIVISION  
 2019 WASHINGTON ST E  
 CHARLESTON WV 25305  
 US

**VENDOR**

Vendor Name, Address and Telephone Number:

*Osburn Associates Inc*  
*Po Box 912*  
*Logan Oh 43138*

04/25/18 10:14:30  
 WV Purchasing Division

**FOR INFORMATION CONTACT THE BUYER**

Mark A Atkins  
 (304) 558-2307  
 mark.a.atkins@wv.gov

*Melinda Thompson*

Signature X

FEIN # *31-1041388*

DATE *4-23-18*

All offers subject to all terms and conditions contained in this solicitation

**ADDITIONAL INFORMATION:**

The West Virginia Purchasing Division is soliciting bids on behalf of the West Virginia Division of Highways (WVDOH) and the West Virginia Division of Corrections (WVDOC) to establish an open-end contract for flat sheet and pre-cut aluminum for use in the manufacturing of highway signing per attached documents.

INVOICE TO		SHIP TO	
DIVISION OF HIGHWAYS TRAFFIC ENGINEERING DIVISION 1900 KANAWHA BLVD E, BLDG 5 RM A550 CHARLESTON WV25305-0430 US		DIVISION OF HIGHWAYS TRAFFIC ENG. TSC - CENTRAL SIGN SHOP 180 DRY BRANCH DR CHARLESTON WV 25306 US	

Line	Comm Ln Desc	Qty	Unit Issue	Unit Price	Total Price
1	Vendor shall use Exhibit_A Pricing Page(s) for bid pricing.	0.00000	EA		

Comm Code	Manufacturer	Specification	Model #
30265000			

**Extended Description :**

FLAT SHEET AND PRE-CUT ALUMINUM - SEE PRICING PAGES ATTACHED:

Note: Vendor shall use Exhibit\_A Pricing Page(s) for bid pricing. If vendor is submitting a bid online, Vendor should enter \$0.00 in the Oasis commodity line.

Vendor shall enter pricing into the Exhibit\_A Pricing Page and must attach with bid.  
See section 18 of Instructions to Bidders.

**SCHEDULE OF EVENTS**

Line	Event	Event Date
1	Technical Questions due by 2:00pm EDT:	2018-04-16

DOT1800000085	<b>Document Phase</b> Final	<b>Document Description</b> FLAT SHEET AND PRE-CUT ALUMINUM	<b>Page 3</b> <b>of 3</b>
---------------	--------------------------------	--	------------------------------

**ADDITIONAL TERMS AND CONDITIONS**

See attached document(s) for additional Terms and Conditions

Quantities listed in this RFQ are approximations only. It is understood and agreed that the contract shall cover the quantities actually ordered for delivery during the term of the contract, whether more or less than the quantities shown. Award will be based on lowest GRAND TOTAL cost.

ITEM NUMBER	ESTIMATED QTY	DESCRIPTION	UNIT COST EACH	EXTENDED TOTAL AMOUNT	DOH INVENTORY SUBCODE	UNSPSC CODE
<b>CLASS II SHEET - 0.080 INCH THICKNESS</b>						
1	80	1-1/2 FT X 12 FT X 0.080 GAUGE THICKNESS	\$ 43.38	\$ 3,470.40	030-218144	30265000
2	30	2 FT X 12 FT X 0.080 GAUGE THICKNESS	\$ 57.84	\$ 1,735.20	224144	30265000
3	80	2-1/2 FT X 12 FT X 0.080 GAUGE THICKNESS	\$ 72.30	\$ 5,784.00	230144	30265000
4	30	3 FT X 12 FT X 0.080 GAUGE THICKNESS	\$ 86.76	\$ 2,602.80	236144	30265000
5	50	3-1/2 FT X 12 FT X 0.080 GAUGE THICKNESS	\$ 101.22	\$ 5,061.00	242144	30265000
6	20	4 FT X 12 FT X 0.080 GAUGE THICKNESS	\$ 115.68	\$ 2,313.60	248144	30265000
7	20	5 FT X 12 FT X 0.080 GAUGE THICKNESS	\$ 144.60	\$ 2,892.00	260144	30265000
<b>CLASS II SHEET - 0.040 INCH THICKNESS</b>						
8	30	4 FT X 12 FT X 0.040 GAUGE THICKNESS	\$ 106.08	\$ 3,182.40	148144	30265000
9	20	5 FT X 12 FT X 0.040 GAUGE THICKNESS	\$ 132.60	\$ 2,652.00	160144	30265000
<b>CLASS III - ALUMINUM PRE-CUT SIGN MATERIAL - 0.080 INCH THICKNESS</b>						
10	20	6 IN X 30 IN HORIZONTAL RECTANGLE	\$ 3.03	\$ 60.60	031-000630	30265000
11	800	9 IN X 24 IN VERTICAL RECTANGLE	\$ 3.62	\$ 2,896.00	031-000924	30265000
12	20	9 IN X 30 IN VERTICAL RECTANGLE	\$ 4.52	\$ 90.40	000930	30265000
13	20	9 IN X 30 IN HORIZONTAL RECTANGLE	\$ 4.52	\$ 90.40	000930	30265000
14	170	9 IN X 42 IN HORIZONTAL RECTANGLE	\$ 6.31	\$ 1,072.70	000942	30265000
15	320	9 IN X 48 IN HORIZONTAL RECTANGLE	\$ 7.23	\$ 2,313.60	000948	30265000
16	200	12 IN X 18 IN VERTICAL RECTANGLE	\$ 3.62	\$ 724.00	001218	30265000
17	1000	12 IN X 24 IN HORIZONTAL RECTANGLE	\$ 4.82	\$ 4,820.00	001224	30265000
18	240	12 IN X 30 IN HORIZONTAL RECTANGLE	\$ 6.03	\$ 1,447.20	001230	30265000
19	1300	12 IN X 36 IN RECTANGLE	\$ 7.23	\$ 9,399.00	001236	30265000
20	20	12 IN X 48 IN VERTICAL RECTANGLE	\$ 9.64	\$ 192.80	001248	30265000
21	800	15 IN X 21 IN HORIZONTAL RECTANGLE	\$ 5.25	\$ 4,200.00	001521	30265000
22	30	15 IN X 30 IN HORIZONTAL RECTANGLE	\$ 7.53	\$ 225.90	001530	30265000
23	180	15 IN X 36 IN HORIZONTAL RECTANGLE	\$ 9.04	\$ 1,627.20	001536	30265000
24	800	15 IN X 42 IN HORIZONTAL RECTANGLE	\$ 10.54	\$ 8,432.00	031-001542	30265000
25	700	15 IN X 48 IN HORIZONTAL RECTANGLE	\$ 12.05	\$ 8,435.00	001548	30265000
26	140	15 IN X 54 IN HORIZONTAL RECTANGLE	\$ 13.55	\$ 1,897.00	001554	30265000
27	30	15 IN X 60 IN HORIZONTAL RECTANGLE	\$ 15.06	\$ 451.80	001560	30265000
28	200	18 IN X 18 IN SQUARE	\$ 5.42	\$ 1,084.00	001818	30265000
29	200	18 IN X 18 IN DIAMOND	\$ 5.42	\$ 1,084.00	001818	30265000
30	500	18 IN X 24 IN VERTICAL RECTANGLE	\$ 7.23	\$ 3,615.00	001824	30265000

31	20	18 IN X 30 IN HORIZONTAL RECTANGLE	\$ 9.04	\$ 180.80	001830	30265000
32	200	18 IN X 36 IN HORIZONTAL RECTANGLE	\$ 10.85	\$ 2,170.00	001836	30265000
33	20	21 IN X 28 IN HORIZONTAL RECTANGLE	\$ 9.84	\$ 196.80	002128	30265000
34	1800	24 IN X 24 IN SQUARE	\$ 9.64	\$ 17,352.00	002424	30265000
35	1800	24 IN X 30 IN VERTICAL RECTANGLE	\$ 12.05	\$ 21,690.00	002430	30265000
36	120	24 IN X 36 IN VERTICAL RECTANGLE	\$ 14.46	\$ 1,735.20	002436	30265000
37	520	24 IN X 48 IN HORIZONTAL RECTANGLE	\$ 19.28	\$ 10,025.60	031-002448	30265000
38	20	24 IN X 72 IN HORIZONTAL RECTANGLE	\$ 28.92	\$ 578.40	002472	30265000
39	1100	30 IN X 30 IN DIAMOND	\$ 15.06	\$ 16,566.00	003030	30265000
40	1100	30 IN X 30 IN SQUARE	\$ 15.06	\$ 16,566.00	003030	30265000
41	200	30 IN X 36 IN VERTICAL RECTANGLE	\$ 18.08	\$ 3,616.00	003036	30265000
42	100	30 IN X 42 IN HORIZONTAL/VERTICAL RECTANGLE	\$ 21.09	\$ 2,109.00	003042	30265000
43	350	30 IN X 48 IN HORIZONTAL/VERTICAL RECTANGLE	\$ 24.10	\$ 8,435.00	003048	30265000
44	20	30 IN X 60 IN HORIZONTAL RECTANGLE	\$ 30.13	\$ 602.60	003060	30265000
45	280	36 IN X 36 IN DIAMOND	\$ 21.69	\$ 6,073.20	003636	30265000
46	280	36 IN X 36 IN SQUARE	\$ 21.69	\$ 6,073.20	003636	30265000
47	20	36 IN X 45 IN HORIZONTAL RECTANGLE	\$ 27.11	\$ 542.20	003645	30265000
48	130	36 IN X 48 IN VERTICAL RECTANGLE	\$ 28.92	\$ 3,759.60	003648	30265000
49	20	36 IN X 60 IN HORIZONTAL RECTANGLE	\$ 36.15	\$ 723.00	003660	30265000
50	370	48 IN X 48 IN DIAMOND	\$ 38.56	\$ 14,267.20	004848	30265000
51	20	48 IN X 60 IN VERTICAL RECTANGLE	\$ 48.20	\$ 964.00	004860	30265000
52	20	24 IN X 24 IN INTERSTATE SHIELD	\$ 9.64	\$ 192.80	022424	30265000
53	20	24 IN X 30 IN INTERSTATE SHIELD	\$ 12.05	\$ 241.00	031-022430	30265000
54	20	36 IN X 36 IN INTERSTATE SHIELD	\$ 21.69	\$ 433.80	023636	30265000
55	20	36 IN X 45 IN INTERSTATE SHIELD	\$ 27.11	\$ 542.20	023645	30265000
56	80	36 IN X 36 IN X 36 IN TRIANGLE	\$ 16.87	\$ 1,349.60	043636	30265000
57	20	48 IN X 48 IN X 48 IN TRIANGLE	\$ 28.92	\$ 578.40	044848	30265000
58	70	30 IN X 30 IN PENTAGON	\$ 15.06	\$ 1,054.20	053030	30265000
59	30	36 IN X 36 IN PENTAGON	\$ 21.69	\$ 650.70	053636	30265000
60	10	48 IN X 48 IN PENTAGON	\$ 38.56	\$ 385.60	054848	30265000
61	50	36 IN X 48 IN X 48 IN PENNANT	\$ 38.56	\$ 1,928.00	063648	30265000
62	10	48 IN X 64 IN X 64 IN PENNANT	\$ 68.55	\$ 685.50	064864	30265000
63	60	36 IN CIRCLE	\$ 21.69	\$ 1,301.40	073600	30265000

64	330	18 IN X 18 IN OCTAGON	\$ 5.42	\$ 1,788.60	081818	30265000
65	1600	30 IN X 30 IN OCTAGON	\$ 15.06	\$ 24,096.00	083030	30265000
66	200	36 IN X 36 IN OCTAGON	\$ 21.69	\$ 4,338.00	083636	30265000
67	20	48 IN X 48 IN OCTAGON	\$ 38.56	\$ 771.20	084848	30265000
68	20	24 IN X 24 IN US ROUTE SHIELD	\$ 9.64	\$ 192.80	022424	30265000
69	20	36 IN X 36 IN US ROUTE SHIELD	\$ 21.69	\$ 433.80	023636	30265000
70	20	24 IN X 30 IN US ROUTE SHIELD	\$ 12.05	\$ 241.00	022430	30265000
71	20	36 IN X 45 IN US ROUTE SHIELD	\$ 27.11	\$ 542.20	023645	30265000
<b>GRAND TOTAL</b>				\$ 259,824.60		

REQUEST FOR QUOTATION  
CRFQ 0803 DOT1800000085  
Flat Sheet and Pre-Cut Aluminum

---

**SPECIFICATIONS**

1. **PURPOSE AND SCOPE:** The West Virginia Purchasing Division is soliciting bids on behalf of the West Virginia Division of Highways (WVDOH) and the West Virginia Division of Corrections (WVDOC) to establish an open-end contract for flat sheet and pre-cut aluminum for use in the manufacturing of highway signing.
  
2. **DEFINITIONS:** The terms listed below shall have the meanings assigned to them below. Additional definitions can be found in section 2 of the General Terms and Conditions.
  - 2.1 **“Contract Item” or “Contract Items”** means the list of items identified in Section 3.1 below and on the Pricing Pages.
  - 2.2 **“Pricing Pages”** means the schedule of prices, estimated order quantity, and totals contained in wvOASIS or attached hereto as Exhibit A and used to evaluate the Solicitation responses.
  - 2.3 **“Solicitation”** means the official notice of an opportunity to supply the State with goods or services that is published by the Purchasing Division.
  - 2.4 **“WVDOH”** means the West Virginia Division of Highways
  - 2.5 **“WVDOC”** means the West Virginia Division of Corrections
  - 2.6 **“FHWA”** means Federal Highway Administration
  - 2.7 **“FT”** means feet.
  - 2.8 **“IN”** means inches
  - 2.9 **“Class II Sheets”** means flat sheet aluminum blanks provided in the sizes and thicknesses specified, without pre-punched mounting holes and without corner radiuses.
  - 2.10 **“Class III Pre-Cuts”** means flat sheet aluminum blanks provided in the thicknesses specified and provided in the pre-cut sign sizes specified, with pre-punched mounting holes and with corner radiuses, if applicable.

REQUEST FOR QUOTATION  
CRFQ 0803 DOT1800000085  
Flat Sheet and Pre-Cut Aluminum

---

**2.11 “WVDOH Standards”** means official standards published by the WVDOH pertaining to design, fabrication, construction, and material testing/acceptance. Examples of WVDOH Standards include the “WVDOH Standard Specifications Roads and Bridges”, the WVDOH “Standard Details Book” (Volumes I, II, and III), and the WVDOH “Materials Procedures”. Specific WVDOH Standards applicable to this RFQ are identified in the RFQ. The specific standards referenced above and any other WVDOH Standard publications referenced herein may be found at the following web address:

<http://www.transportation.wv.gov/highways/engineering/Pages/publications.aspx>

### 3. GENERAL REQUIREMENTS:

**3.1 Contract Items and Mandatory Requirements:** Vendor shall provide Agency with the Contract Items listed below on an open-end and continuing basis. Contract Items must meet or exceed the mandatory requirements as shown below.

The specifications of this RFQ and/or any WVDOH Standards referenced in and/or attached to this RFQ may include references to specific recognized “industry standard” specifications which are issued by third parties, such as the American Society for Testing and Materials (ASTM) and the American Association of State and Highway Transportation Officials (AASHTO). Such specifications are protected by strict copyright restrictions and cannot be published as part of this RFQ. The ability to access such specifications shall be considered a mandatory requirement for participation in the RFQ process as a Vendor or as a supplier to the Vendor, as applicable.

All Material shall be in accordance with Section 661 of the West Virginia Division of Highways’ Standard Specifications for Roads and Bridges, latest edition, as applicable, unless otherwise specified or allowed for herein.

Class II Sheets and Class III Pre-Cuts shall be either 6061-T6 or 5052-H38 aluminum alloy and shall meet ASTM specifications ASTM-B-209 and ASTM-B449. The Vendor should state which alloy will be provided under this Contract at the location provided in Section 8.5. This Contract shall not be awarded without this information.

Alloy 5052-H38 stable flat sheet must be thermal flattened to reduce internal stresses and shall show excellent flatness after shear by full width of sheet.



REQUEST FOR QUOTATION  
CRFQ 0803 DOT1800000085  
Flat Sheet and Pre-Cut Aluminum

---

All exposed aluminum surfaces shall be given a chromate type chemical conversion treatment conforming to ASTM-B-449 Class I or Class II.

For each Release Order, the Agency reserves the right to sample each coil of aluminum from which the Vendor intends to fabricate Class II Sheets or Class III Pre-Cuts for conformance with the above specifications. If fabricated into Class III Pre-Cuts, each size may be sampled. The Agency further reserves the right to random sample upon delivery.

All sheets to be commercially flat, free from waves, scratches and buckles, corrosion, analysis markings, heat or oil stains, or any blemish which will prevent finishing to a bright uniform surface by a light cleaning process (bright dip), which prepares aluminum sheets for the application of paint, reflective sheeting, electro-cut sheeting, etc. All sheets to be free of oil and grease, and must be dry and not contaminated with waxes or dirt. Plugged holes will not be accepted. The edges, holes, and corners of the aluminum sheets shall be smooth, de-burred and free of dents and deformation.

Hole punching, if required, shall be per the reference noted on the list of items provided in **Exhibit B**. If the Punching Detail column indicates "Federal", then the punching layout shall be in accordance with the "Blank Standards" section of the FHWA publication "Standard Highway Signs", latest edition. If the Punching Detail column indicates "Special Detail", then the punching layout shall be in accordance with the applicable special detail contained within **Exhibit B**. If the Punching Detail column indicates "TP1-1", "TP1-2", "TP1-3", or "TP1-4", then the punching layout shall be in accordance with the Standard Detail sheet of the same designation contained within the WVDOH Publication "Standard Details Book Vol. II: Signing, Signals, Lighting, and Markings", latest edition.

All corner radiuses shall be 1-1/2 inches or in accordance with the previously referenced "Blank Standards" section of the FHWA publication "Standard Highway Signs", latest edition.

The latest edition of the FHWA publication "Standard Highway Signs" may be found at the following web address:

[https://mutcd.fhwa.dot.gov/ser-shs\\_millennium.htm](https://mutcd.fhwa.dot.gov/ser-shs_millennium.htm)

**3.1.1 Contract Item Numbers 1-7 - CLASS II SHEET – 0.080 INCH THICKNESS**

**3.1.1.1** Contract Item Numbers 1-7 **shall not** have holes or corner radiuses.

REQUEST FOR QUOTATION  
CRFQ 0803 DOT1800000085  
Flat Sheet and Pre-Cut Aluminum

---

3.1.1.2 Contract Item Numbers 1-7 shall meet a tolerance for buckles and edgewaves of not more than 3/8 inch.

**3.1.2 Contract Item Numbers 8-9 - CLASS II SHEET – 0.040 INCH THICKNESS**

3.1.2.1 Contract Item Numbers 8-9 **shall not** have holes or corner radiuses.

3.1.2.2 Contract Item Numbers 8-9 shall meet a tolerance for buckles and edgewaves of not more than 3/8 inch.

**3.1.3 Contract Item Numbers 10-71 - CLASS III PRE-CUT – 0.080 INCH THICKNESS**

3.1.3.1 Contract Item Numbers 10-71 **shall have** holes placed as specified herein.

3.1.3.2 Contract Item Numbers 10-71 shall have corner radiuses as shown on the applicable detail.

3.1.3.3 Contract Item Numbers 10-69 shall meet the following maximum tolerances for buckles and edgewaves based on square footage. Both the long and short dimensions of each sign blank shall meet the following tolerances:

≤ 4 SQ. FT.	3/16 INCH
> 4 SQ. FT. AND ≤ 6 SQ. FT.	5/16 INCH
> 6 SQ. FT.	3/8 INCH

**4. CONTRACT AWARD:**

**4.1 Contract Award:** The Contract is intended to provide Agencies with a purchase price on all Contract Items. The Contract shall be awarded to the Vendor that provides the Contract Items meeting the required specifications for the lowest overall total cost as shown on the Pricing Pages.

REQUEST FOR QUOTATION  
CRFQ 0803 DOT1800000085  
Flat Sheet and Pre-Cut Aluminum

---

- 4.2 Pricing Pages:** Vendor should complete the Pricing Pages by providing a unit price for each item listed. Vendor should complete the Pricing Pages in their entirety as failure to do so may result in Vendor's bids being disqualified.

The Pricing Pages contain a list of the Contract Items and estimated purchase volume. The estimated purchase volume for each item represents the approximate volume of anticipated purchases only. No future use of the Contract or any individual item is guaranteed or implied.

Vendor should complete the **Exhibit A** Pricing Pages by entering the Unit Price for each commodity item. The Pricing Pages have been provided in Excel format with the Grand Total automatically calculated when the Unit Price is entered. However, it is the Vendor's responsibility to ensure their bid is totaled correctly before submitting. In most cases, the Vendor can request an electronic copy of the Pricing Pages for bid purposes by sending an email request to the following address: [Mark.A.Atkins@wv.gov](mailto:Mark.A.Atkins@wv.gov).

**5. ORDERING AND PAYMENT:**

- 5.1 Ordering:** Vendor shall accept orders through wvOASIS, regular mail, facsimile, e-mail, or any other written form of communication. Vendor may, but is not required to, accept on-line orders through a secure internet ordering portal/website. If Vendor has the ability to accept on-line orders, it should include in its response a brief description of how Agencies may utilize the on-line ordering system. Vendor shall ensure that its on-line ordering system is properly secured prior to processing Agency orders on-line.
- 5.2 Payment:** Vendor shall accept payment in accordance with the payment procedures of the State of West Virginia.
- 5.3 Minimum Order Size:** The minimum order for free shipping is 10,000 pounds. The Agency will pay delivery charges on all orders less than 10,000 pounds, provided that Vendor invoices those delivery costs as a separate charge with the original freight bill attached to the invoice.

For the purposes of determining if the order meets the minimum weight requirement specified, the estimated weight per unit values listed on **Exhibit B** shall be used. These weights are calculated based on an assumed aluminum unit weight of 168.5 pounds / cubic foot. Values are rounded to the nearest whole pound. The weight calculations for each size sheet or blank is based on the calculated square footage of each sheet or blank, based on the dimensions shown. Note that although the

REQUEST FOR QUOTATION  
CRFQ 0803 DOT1800000085  
Flat Sheet and Pre-Cut Aluminum

---

dimensions shown for interstate shields and U.S. route shields are nominal and not the actual blank dimensions, the nominal dimensions are used to calculate the blank square footage for use in weight calculations regardless.

- 5.4 Shop Drawings:** Shop drawing submittal and approval will be required for orders if indicated on the Release Order. The Vendor shall not deliver any material until receipt of approved shop drawings, if required. No additional Working Days will be added to the Delivery Time specified in Section 6.1 if shop drawings are required. Shop drawing transmittal instructions will typically be indicated on the Release Order.

**6. DELIVERY AND RETURN:**

- 6.1 Delivery Time:** Vendor shall deliver standard orders within thirty-five (35) Working Days after orders are received. Vendor shall ship all orders in accordance with the above schedule and shall not hold orders until a minimum delivery quantity is met.
- 6.2 Late Delivery:** The Agency placing the order under this Contract must be notified in writing if orders will be delayed for any reason. Any delay in delivery that could cause harm to an Agency will be grounds for cancellation of the delayed order, and/or obtaining the items ordered from a third party.

Any Agency seeking to obtain items from a third party under this provision must first obtain approval of the Purchasing Division.

Regardless of whether or not the vendor provides written notification of an order delay, if the Vendor is unable to deliver in full within thirty-five (35) Working Days after receipt of the order, the Vendor shall be subject to a daily (per Calendar Day) penalty in the amount of \$150 until the order is received in full. This penalty shall be assessed by subtracting the penalty from the original total value of the Release Order. The penalty shall not exceed the original total amount of the Release Order.

- 6.3 Delivery Payment/Risk of Loss:** Standard order delivery shall be F.O.B. destination to the Agency's location. Vendor shall include the cost of standard order delivery charges in its bid pricing/discount and is not permitted to charge the Agency separately for such delivery, except for as allowed for in Section 5.3. The Agency will pay delivery charges on all emergency orders provided that Vendor invoices those delivery costs as a separate charge with the original freight bill attached to the invoice.
- 6.4 Return of Unacceptable Items:** If the Agency deems the Contract Items to be unacceptable, the Contract Items shall be returned to Vendor at Vendor's expense

**REQUEST FOR QUOTATION  
CRFQ 0803 DOT1800000085  
Flat Sheet and Pre-Cut Aluminum**

---

and with no restocking charge. Vendor shall either make arrangements for the return within five (5) days of being notified that items are unacceptable, or permit the Agency to arrange for the return and reimburse Agency for delivery expenses. If the original packaging cannot be utilized for the return, Vendor will supply the Agency with appropriate return packaging upon request. All returns of unacceptable items shall be F.O.B. the Agency's location. The returned product shall either be replaced, or the Agency shall receive a full credit or refund for the purchase price, at the Agency's discretion. If the Agency elects to have the returned items replaced, the provisions of Sections 6.1 and 6.2 shall remain in effect until the order is completed in full with material accepted by the Agency.

**6.5 Return Due to Agency Error:** Items ordered in error by the Agency will be returned for credit within 30 days of receipt, F.O.B. Vendor's location. Vendor shall not charge a restocking fee if returned products are in a resalable condition. Items shall be deemed to be in a resalable condition if they are unused and in the original packaging. Any restocking fee for items not in a resalable condition shall be the lower of the Vendor's customary restocking fee or 5% of the total invoiced value of the returned items.

**6.6 Packaging & Delivery Method:** To prevent scratching and damage to individual sheets, the stacks of aluminum blanks shall be banded to the pallets securely enough to prevent shifting between individual sheets during shipping. When shipped by way of a non-enclosed truck, the shipment shall be tarped. The pallets must be of a suitable construction to withstand normal handling and must be free of dirt, oil, grease and all foreign matter. A piece of cardboard or paper shall be placed and secured under the strapping at the top of each pallet of blanks. The top of this piece of cardboard or paper is to be marked with the size of the blanks including on the pallet, and the quantity of blanks on the pallet. Varying size blanks shall not be mixed on a pallet. Horizontal and vertical rectangles of the same size shall not be mixed on a pallet. Square and diamond blanks of the same size shall not be mixed on a pallet. To facilitate ease in performing verification counts upon delivery, each group of ten (10) blanks on a pallet shall be stacked such that they are slightly offset from the group of ten (10) blanks immediately preceding and proceeding it.

**All Class II sheets shall be packed in crates/pallets not to exceed 2,000 pounds.**

**All Class III pre-cuts are to be packed in crates/pallets not to exceed 2,000 pounds.**

No stacks shall contain more than 500 ea. blanks due to storage rack space limitations. In addition, the following requirements shall apply:

REQUEST FOR QUOTATION  
CRFQ 0803 DOT180000085  
Flat Sheet and Pre-Cut Aluminum

---

- 0.080 inch thick blanks larger than 7.21 square feet (and up to 18 square feet) shall be 100 ea. maximum per pallet.
- 0.080 inch thick blanks less than 7.21 square feet shall be 250 ea. maximum per pallet, with the exception of blanks that are no more than 3.6 square feet.
- 0.080 inch thick blanks up to 3.6 square feet shall be 500 ea. maximum per pallet.

Stacks shall not be larger than the maximum allowed, as shown in **Exhibit B**.

A packing slip shall accompany each delivery.

**7. VENDOR DEFAULT:**

**7.1** The following shall be considered a vendor default under this Contract.

- 7.1.1 Failure to provide Contract Items in accordance with the requirements contained herein.
- 7.1.2 Failure to comply with other specifications and requirements contained herein.
- 7.1.3 Failure to comply with any laws, rules, and ordinances applicable to the Contract Services provided under this Contract.
- 7.1.4 Failure to remedy deficient performance upon request.

**7.2** The following remedies shall be available to Agency upon default.

- 7.2.1 Immediate cancellation of the Contract.
- 7.2.2 Immediate cancellation of one or more release orders issued under this Contract.
- 7.2.3 Any other remedies available in law or equity.

**8. MISCELLANEOUS:**

**8.1 No Substitutions:** Vendor shall supply only Contract Items submitted in response to the Solicitation unless a contract modification is approved in accordance with the provisions contained in this Contract.

**8.2 Vendor Supply:** Vendor must carry sufficient inventory of the Contract Items being offered to fulfill its obligations under this Contract. By signing its bid, Vendor certifies that it can supply the Contract Items contained in its bid response.

REQUEST FOR QUOTATION  
CRFQ 0803 DOT1800000085  
Flat Sheet and Pre-Cut Aluminum

---

**8.3 Reports:** Vendor shall provide quarterly reports and annual summaries to the Agency showing the Agency's items purchased, quantities of items purchased, and total dollar value of the items purchased. Vendor shall also provide reports, upon request, showing the items purchased during the term of this Contract, the quantity purchased for each of those items, and the total value of purchases for each of those items. Failure to supply such reports may be grounds for cancellation of this Contract.

**8.4 Contract Manager:** During its performance of this Contract, Vendor must designate and maintain a primary contract manager responsible for overseeing Vendor's responsibilities under this Contract. The Contract manager must be available during normal business hours to address any customer service or other issues related to this Contract. Vendor should list its Contract manager and his or her contact information below.

**Contract Manager:** Jennifer Treadway  
**Telephone Number:** 800 523-8917  
**Fax Number:** 740-385-8016  
**Email Address:** jennifert@oshvras.com

**8.5 Aluminum Material Designation:** Vendor should specify the material designation of the aluminum to be supplied under this Contract (6061-T6 or 5052-H38) below.

5052 H38

## INSTRUCTIONS TO VENDORS SUBMITTING BIDS

**1. REVIEW DOCUMENTS THOROUGHLY:** The attached documents contain a solicitation for bids. Please read these instructions and all documents attached in their entirety. These instructions provide critical information about requirements that if overlooked could lead to disqualification of a Vendor's bid. All bids must be submitted in accordance with the provisions contained in these instructions and the Solicitation. Failure to do so may result in disqualification of Vendor's bid.

**2. MANDATORY TERMS:** The Solicitation may contain mandatory provisions identified by the use of the words "must," "will," and "shall." Failure to comply with a mandatory term in the Solicitation will result in bid disqualification.

**3. PREBID MEETING:** The item identified below shall apply to this Solicitation.

A pre-bid meeting will not be held prior to bid opening

A **NON-MANDATORY PRE-BID** meeting will be held at the following place and time:

A **MANDATORY PRE-BID** meeting will be held at the following place and time:

All Vendors submitting a bid must attend the mandatory pre-bid meeting. Failure to attend the mandatory pre-bid meeting shall result in disqualification of the Vendor's bid. No one person attending the pre-bid meeting may represent more than one Vendor.

An attendance sheet provided at the pre-bid meeting shall serve as the official document verifying attendance. The State will not accept any other form of proof or documentation to verify attendance. Any person attending the pre-bid meeting on behalf of a Vendor must list on the attendance sheet his or her name and the name of the Vendor he or she is representing.



Additionally, the person attending the pre-bid meeting should include the Vendor's E-Mail address, phone number, and Fax number on the attendance sheet. It is the Vendor's responsibility to locate the attendance sheet and provide the required information. Failure to complete the attendance sheet as required may result in disqualification of Vendor's bid.

All Vendors should arrive prior to the starting time for the pre-bid. Vendors who arrive after the starting time but prior to the end of the pre-bid will be permitted to sign in, but are charged with knowing all matters discussed at the pre-bid.

Questions submitted at least five business days prior to a scheduled pre-bid will be discussed at the pre-bid meeting if possible. Any discussions or answers to questions at the pre-bid meeting are preliminary in nature and are non-binding. Official and binding answers to questions will be published in a written addendum to the Solicitation prior to bid opening.

**4. VENDOR QUESTION DEADLINE:** Vendors may submit questions relating to this Solicitation to the Purchasing Division. Questions must be submitted in writing. All questions must be submitted on or before the date listed below and to the address listed below in order to be considered. A written response will be published in a Solicitation addendum if a response is possible and appropriate. Non-written discussions, conversations, or questions and answers regarding this Solicitation are preliminary in nature and are nonbinding.

Submitted e-mails should have solicitation number in the subject line.

Question Submission Deadline: April 16, 2018 due by 2:00pm EDT

Submit Questions to: Mark Atkins, Senior Buyer  
2019 Washington Street, East  
Charleston, WV 25305  
Fax: (304) 558-4115 (Vendors should not use this fax number for bid submission)  
Email: Mark.A.Atkins@wv.gov

**5. VERBAL COMMUNICATION:** Any verbal communication between the Vendor and any State personnel is not binding, including verbal communication at the mandatory pre-bid conference. Only information issued in writing and added to the Solicitation by an official written addendum by the Purchasing Division is binding.

**6. BID SUBMISSION:** All bids must be submitted electronically through wvOASIS or signed and delivered by the Vendor to the Purchasing Division at the address listed below on or before the date and time of the bid opening. Any bid received by the Purchasing Division staff is considered to be in the possession of the Purchasing Division and will not be returned for any reason. The Purchasing Division will not accept bids, modification of bids, or addendum acknowledgment forms via e-mail. Acceptable delivery methods include electronic submission via wvOASIS, hand delivery, delivery by courier, or facsimile.

The bid delivery address is:  
Department of Administration, Purchasing Division  
2019 Washington Street East  
Charleston, WV 25305-0130

A bid that is not submitted electronically through wvOASIS should contain the information listed below on the face of the envelope or the bid may be rejected by the Purchasing Division.:

SEALED BID: Aluminum sheets  
BUYER: Mark Atkins, File #33  
SOLICITATION NO.: CRFQ 0803 DOT1800000085  
BID OPENING DATE: 04/26/2018  
BID OPENING TIME: 1:30pm EDT  
FAX NUMBER: 304-558-3970

The Purchasing Division may prohibit the submission of bids electronically through wvOASIS at its sole discretion. Such a prohibition will be contained and communicated in the wvOASIS system resulting in the Vendor's inability to submit bids through wvOASIS. Submission of a response to an Expression or Interest or Request for Proposal is not permitted in wvOASIS.

**For Request For Proposal ("RFP") Responses Only:** In the event that Vendor is responding to a request for proposal, the Vendor shall submit one original technical and one original cost proposal plus N/A convenience copies of each to the Purchasing Division at the address shown above. Additionally, the Vendor should identify the bid type as either a technical or cost proposal on the face of each bid envelope submitted in response to a request for proposal as follows:

BID TYPE: (This only applies to CRFP)

- Technical  
 Cost

**7. BID OPENING:** Bids submitted in response to this Solicitation will be opened at the location identified below on the date and time listed below. Delivery of a bid after the bid opening date and time will result in bid disqualification. For purposes of this Solicitation, a bid is considered delivered when confirmation of delivery is provided by wvOASIS (in the case of electronic submission) or when the bid is time stamped by the official Purchasing Division time clock (in the case of hand delivery).

Bid Opening Date and Time: April 26, 2018 at 1:30pm EDT

Bid Opening Location: Department of Administration, Purchasing Division  
2019 Washington Street East  
Charleston, WV 25305-0130

**8. ADDENDUM ACKNOWLEDGEMENT:** Changes or revisions to this Solicitation will be made by an official written addendum issued by the Purchasing Division. Vendor should acknowledge receipt of all addenda issued with this Solicitation by completing an Addendum Acknowledgment Form, a copy of which is included herewith. Failure to acknowledge addenda may result in bid disqualification. The addendum acknowledgement should be submitted with the bid to expedite document processing.

**9. BID FORMATTING:** Vendor should type or electronically enter the information onto its bid to prevent errors in the evaluation. Failure to type or electronically enter the information may result in bid disqualification.

**10. ALTERNATES:** Any model, brand, or specification listed in this Solicitation establishes the acceptable level of quality only and is not intended to reflect a preference for, or in any way favor, a particular brand or vendor. Vendors may bid alternates to a listed model or brand provided that the alternate is at least equal to the model or brand and complies with the required specifications. The equality of any alternate being bid shall be determined by the State at its sole discretion. Any Vendor bidding an alternate model or brand should clearly identify the alternate items in its bid and should include manufacturer's specifications, industry literature, and/or any other relevant documentation demonstrating the equality of the alternate items. Failure to provide information for alternate items may be grounds for rejection of a Vendor's bid.

**11. EXCEPTIONS AND CLARIFICATIONS:** The Solicitation contains the specifications that shall form the basis of a contractual agreement. Vendor shall clearly mark any exceptions, clarifications, or other proposed modifications in its bid. Exceptions to, clarifications of, or modifications of a requirement or term and condition of the Solicitation may result in bid disqualification.

**12. COMMUNICATION LIMITATIONS:** In accordance with West Virginia Code of State Rules §148-1-6.6, communication with the State of West Virginia or any of its employees regarding this Solicitation during the solicitation, bid, evaluation or award periods, except through the Purchasing Division, is strictly prohibited without prior Purchasing Division approval. Purchasing Division approval for such communication is implied for all agency delegated and exempt purchases.

**13. REGISTRATION:** Prior to Contract award, the apparent successful Vendor must be properly registered with the West Virginia Purchasing Division and must have paid the \$125 fee, if applicable.

**14. UNIT PRICE:** Unit prices shall prevail in cases of a discrepancy in the Vendor's bid.

**15. PREFERENCE:** Vendor Preference may only be granted upon written request and only in accordance with the West Virginia Code § 5A-3-37 and the West Virginia Code of State Rules. A Vendor Preference Certificate form has been attached hereto to allow Vendor to apply for the preference. Vendor's failure to submit the Vendor Preference Certificate form with its bid will result in denial of Vendor Preference. Vendor Preference does not apply to construction projects.

**16. SMALL, WOMEN-OWNED, OR MINORITY-OWNED BUSINESSES:** For any solicitations publicly advertised for bid, in accordance with West Virginia Code §5A-3-37(a)(7) and W. Va. CSR § 148-22-9, any non-resident vendor certified as a small, women-owned, or minority-owned business under W. Va. CSR § 148-22-9 shall be provided the same preference made available to any resident vendor. Any non-resident small, women-owned, or minority-owned business must identify itself as such in writing, must submit that writing to the Purchasing Division with its bid, and must be properly certified under W. Va. CSR § 148-22-9 prior to contract award to receive the preferences made available to resident vendors. Preference for a non-resident small, women-owned, or minority owned business shall be applied in accordance with W. Va. CSR § 148-22-9.

**17. WAIVER OF MINOR IRREGULARITIES:** The Director reserves the right to waive minor irregularities in bids or specifications in accordance with West Virginia Code of State Rules § 148-1-4.6.

**18. ELECTRONIC FILE ACCESS RESTRICTIONS:** Vendor must ensure that its submission in wvOASIS can be accessed and viewed by the Purchasing Division staff immediately upon bid opening. The Purchasing Division will consider any file that cannot be immediately accessed and viewed at the time of the bid opening (such as, encrypted files, password protected files, or incompatible files) to be blank or incomplete as context requires, and are therefore unacceptable. A vendor will not be permitted to unencrypt files, remove password protections, or resubmit documents after bid opening to make a file viewable if those documents are required with the bid. A Vendor may be required to provide document passwords or remove access restrictions to allow the Purchasing Division to print or electronically save documents provided that those documents are viewable by the Purchasing Division prior to obtaining the password or removing the access restriction.

**19. NON-RESPONSIBLE:** The Purchasing Division Director reserves the right to reject the bid of any vendor as Non-Responsible in accordance with W. Va. Code of State Rules § 148-1-5.3, when the Director determines that the vendor submitting the bid does not have the capability to fully perform, or lacks the integrity and reliability to assure good-faith performance.”

**20. ACCEPTANCE/REJECTION:** The State may accept or reject any bid in whole, or in part in accordance with W. Va. Code of State Rules § 148-1-4.5. and § 148-1-6.4.b.”

**21. YOUR SUBMISSION IS A PUBLIC DOCUMENT:** Vendor’s entire response to the Solicitation and the resulting Contract are public documents. As public documents, they will be disclosed to the public following the bid/proposal opening or award of the contract, as required by the competitive bidding laws of West Virginia Code §§ 5A-3-1 et seq., 5-22-1 et seq., and 5G-1-1 et seq. and the Freedom of Information Act West Virginia Code §§ 29B-1-1 et seq.

**DO NOT SUBMIT MATERIAL YOU CONSIDER TO BE CONFIDENTIAL, A TRADE SECRET, OR OTHERWISE NOT SUBJECT TO PUBLIC DISCLOSURE.**

Submission of any bid, proposal, or other document to the Purchasing Division constitutes your explicit consent to the subsequent public disclosure of the bid, proposal, or document. The Purchasing Division will disclose any document labeled “confidential,” “proprietary,” “trade secret,” “private,” or labeled with any other claim against public disclosure of the documents, to include any “trade secrets” as defined by West Virginia Code § 47-22-1 et seq. All submissions are subject to public disclosure without notice.

**22. INTERESTED PARTY DISCLOSURE:** W. Va. Code § 6D-1-2 requires that for contracts with an actual or estimated value of at least \$100,000, the vendor must submit to the Purchasing Division a disclosure of interested parties to the contract, prior to contract award. That disclosure must occur on the form prescribed and approved by the WV Ethics Commission. A copy of that form is included with this solicitation or can be obtained from the WV Ethics Commission.

“Interested parties” means: (1) A business entity performing work or service pursuant to, or in furtherance of, the applicable contract, including specifically sub-contractors; (2) the person(s) who have an ownership interest equal to or greater than 25% in the business entity performing work or service pursuant to, or in furtherance of, the applicable contract; and (3) the person or business entity, if any, that served as a compensated broker or intermediary to actively facilitate the applicable contract or negotiated the terms of the applicable contract with the state agency: Provided, That subdivision (2) shall be inapplicable if a business entity is a publicly traded company: Provided, however, That subdivision (3) shall not include persons or business entities performing legal services related to the negotiation or drafting of the applicable contract.

**23. WITH THE BID REQUIREMENTS:** In instances where these specifications require documentation or other information with the bid, and a vendor fails to provide it with the bid, the Director of the Purchasing Division reserves the right to request those items after bid opening and prior to contract award pursuant to the authority to waive minor irregularities in bids or specifications under W. Va. CSR § 148-1-4.6. This authority does not apply to instances where state law mandates receipt with the bid.

## **GENERAL TERMS AND CONDITIONS:**

**1. CONTRACTUAL AGREEMENT:** Issuance of a Award Document signed by the Purchasing Division Director, or his designee, and approved as to form by the Attorney General's office constitutes acceptance of this Contract made by and between the State of West Virginia and the Vendor. Vendor's signature on its bid signifies Vendor's agreement to be bound by and accept the terms and conditions contained in this Contract.

**2. DEFINITIONS:** As used in this Solicitation/Contract, the following terms shall have the meanings attributed to them below. Additional definitions may be found in the specifications included with this Solicitation/Contract.

**2.1. "Agency" or "Agencies"** means the agency, board, commission, or other entity of the State of West Virginia that is identified on the first page of the Solicitation or any other public entity seeking to procure goods or services under this Contract.

**2.2. "Bid" or "Proposal"** means the vendors submitted response to this solicitation.

**2.3. "Contract"** means the binding agreement that is entered into between the State and the Vendor to provide the goods or services requested in the Solicitation.

**2.4. "Director"** means the Director of the West Virginia Department of Administration, Purchasing Division.

**2.5. "Purchasing Division"** means the West Virginia Department of Administration, Purchasing Division.

**2.6. "Award Document"** means the document signed by the Agency and the Purchasing Division, and approved as to form by the Attorney General, that identifies the Vendor as the contract holder.

**2.7. "Solicitation"** means the official notice of an opportunity to supply the State with goods or services that is published by the Purchasing Division.

**2.8. "State"** means the State of West Virginia and/or any of its agencies, commissions, boards, etc. as context requires.

**2.9. "Vendor" or "Vendors"** means any entity submitting a bid in response to the Solicitation, the entity that has been selected as the lowest responsible bidder, or the entity that has been awarded the Contract as context requires.

**3. CONTRACT TERM; RENEWAL; EXTENSION:** The term of this Contract shall be determined in accordance with the category that has been identified as applicable to this Contract below:

**Term Contract**

**Initial Contract Term:** This Contract becomes effective on upon award and extends for a period of one (1) year(s).

**Renewal Term:** This Contract may be renewed upon the mutual written consent of the Agency, and the Vendor, with approval of the Purchasing Division and the Attorney General's office (Attorney General approval is as to form only). Any request for renewal should be delivered to the Agency and then submitted to the Purchasing Division thirty (30) days prior to the expiration date of the initial contract term or appropriate renewal term. A Contract renewal shall be in accordance with the terms and conditions of the original contract. Unless otherwise specified below, renewal of this Contract is limited to three (3) successive one (1) year periods or multiple renewal periods of less than one year, provided that the multiple renewal periods do not exceed the total number of months available in all renewal years combined. Automatic renewal of this Contract is prohibited. Renewals must be approved by the Vendor, Agency, Purchasing Division and Attorney General's office (Attorney General approval is as to form only)

**Alternate Renewal Term** – This contract may be renewed for \_\_\_\_\_ successive \_\_\_\_\_ year periods or shorter periods provided that they do not exceed the total number of months contained in all available renewals. Automatic renewal of this Contract is prohibited. Renewals must be approved by the Vendor, Agency, Purchasing Division and Attorney General's office (Attorney General approval is as to form only)

**Delivery Order Limitations:** In the event that this contract permits delivery orders, a delivery order may only be issued during the time this Contract is in effect. Any delivery order issued within one year of the expiration of this Contract shall be effective for one year from the date the delivery order is issued. No delivery order may be extended beyond one year after this Contract has expired.

**Fixed Period Contract:** This Contract becomes effective upon Vendor's receipt of the notice to proceed and must be completed within \_\_\_\_\_ days.

**Fixed Period Contract with Renewals:** This Contract becomes effective upon Vendor's receipt of the notice to proceed and part of the Contract more fully described in the attached specifications must be completed within \_\_\_\_\_ days. Upon completion of the work covered by the preceding sentence, the vendor agrees that maintenance, monitoring, or warranty services will be provided for \_\_\_\_\_ year(s) thereafter.

**One Time Purchase:** The term of this Contract shall run from the issuance of the Award Document until all of the goods contracted for have been delivered, but in no event will this Contract extend for more than one fiscal year.

**Other:** See attached.

**4. NOTICE TO PROCEED:** Vendor shall begin performance of this Contract immediately upon receiving notice to proceed unless otherwise instructed by the Agency. Unless otherwise specified, the fully executed Award Document will be considered notice to proceed.

**5. QUANTITIES:** The quantities required under this Contract shall be determined in accordance with the category that has been identified as applicable to this Contract below.

**Open End Contract:** Quantities listed in this Solicitation are approximations only, based on estimates supplied by the Agency. It is understood and agreed that the Contract shall cover the quantities actually ordered for delivery during the term of the Contract, whether more or less than the quantities shown.

**Service:** The scope of the service to be provided will be more clearly defined in the specifications included herewith.

**Combined Service and Goods:** The scope of the service and deliverable goods to be provided will be more clearly defined in the specifications included herewith.

**One Time Purchase:** This Contract is for the purchase of a set quantity of goods that are identified in the specifications included herewith. Once those items have been delivered, no additional goods may be procured under this Contract without an appropriate change order approved by the Vendor, Agency, Purchasing Division, and Attorney General's office.

**6. EMERGENCY PURCHASES:** The Purchasing Division Director may authorize the Agency to purchase goods or services in the open market that Vendor would otherwise provide under this Contract if those goods or services are for immediate or expedited delivery in an emergency. Emergencies shall include, but are not limited to, delays in transportation or an unanticipated increase in the volume of work. An emergency purchase in the open market, approved by the Purchasing Division Director, shall not constitute a breach of this Contract and shall not entitle the Vendor to any form of compensation or damages. This provision does not excuse the State from fulfilling its obligations under a One Time Purchase contract.

**7. REQUIRED DOCUMENTS:** All of the items checked below must be provided to the Purchasing Division by the Vendor as specified below.

**BID BOND (Construction Only):** Pursuant to the requirements contained in W. Va. Code § 5-22-1(c), All Vendors submitting a bid on a construction project shall furnish a valid bid bond in the amount of five percent (5%) of the total amount of the bid protecting the State of West Virginia. The bid bond must be submitted with the bid.

**PERFORMANCE BOND:** The apparent successful Vendor shall provide a performance bond in the amount of \_\_\_\_\_. The performance bond must be received by the Purchasing Division prior to Contract award. On construction contracts, the performance bond must be 100% of the Contract value.



**LABOR/MATERIAL PAYMENT BOND:** The apparent successful Vendor shall provide a labor/material payment bond in the amount of 100% of the Contract value. The labor/material payment bond must be delivered to the Purchasing Division prior to Contract award.

In lieu of the Bid Bond, Performance Bond, and Labor/Material Payment Bond, the Vendor may provide certified checks, cashier's checks, or irrevocable letters of credit. Any certified check, cashier's check, or irrevocable letter of credit provided in lieu of a bond must be of the same amount and delivered on the same schedule as the bond it replaces. A letter of credit submitted in lieu of a performance and labor/material payment bond will only be allowed for projects under \$100,000. Personal or business checks are not acceptable. Notwithstanding the foregoing, West Virginia Code § 5-22-1 (d) mandates that a vendor provide a performance and labor/material payment bond for construction projects. Accordingly, substitutions for the performance and labor/material payment bonds for construction projects is not permitted.

**MAINTENANCE BOND:** The apparent successful Vendor shall provide a two (2) year maintenance bond covering the roofing system. The maintenance bond must be issued and delivered to the Purchasing Division prior to Contract award.

**LICENSE(S) / CERTIFICATIONS / PERMITS:** In addition to anything required under the Section entitled Licensing, of the General Terms and Conditions, the apparent successful Vendor shall furnish proof of the following licenses, certifications, and/or permits prior to Contract award, in a form acceptable to the Purchasing Division.

The apparent successful Vendor shall also furnish proof of any additional licenses or certifications contained in the specifications prior to Contract award regardless of whether or not that requirement is listed above.

**8. INSURANCE:** The apparent successful Vendor shall furnish proof of the insurance identified by a checkmark below prior to Contract award. Subsequent to contract award, and prior to the insurance expiration date, Vendor shall provide the Agency with proof that the insurance mandated herein has been continued. Vendor must also provide Agency with immediate notice of any changes in its insurance policies mandated herein, including but not limited to, policy cancelation, policy reduction, or change in insurers. The insurance coverages identified below must be maintained throughout the life of this contract. The apparent successful Vendor shall also furnish proof of any additional insurance requirements contained in the specifications prior to Contract award regardless of whether or not that insurance requirement is listed in this section.

Vendor must maintain:

**Commercial General Liability Insurance** in at least an amount of:

\$250,000.00

**Automobile Liability Insurance** in at least an amount of: \_\_\_\_\_

**Professional/Malpractice/Errors and Omission Insurance** in at least an amount of: \_\_\_\_\_

**Commercial Crime and Third Party Fidelity Insurance** in an amount of: \_\_\_\_\_

**Cyber Liability Insurance** in an amount of: \_\_\_\_\_

**Builders Risk Insurance** in an amount equal to 100% of the amount of the Contract.

**9. WORKERS' COMPENSATION INSURANCE:** The apparent successful Vendor shall comply with laws relating to workers compensation, shall maintain workers' compensation insurance when required, and shall furnish proof of workers' compensation insurance upon request.

**10. [Reserved]**

**11. LIQUIDATED DAMAGES:** This clause shall in no way be considered exclusive and shall not limit the State or Agency's right to pursue any other available remedy. Vendor shall pay liquidated damages in the amount specified below or as described in the specifications:

\_\_\_\_\_ for \_\_\_\_\_

Liquidated Damages Contained in the Specifications

**12. ACCEPTANCE:** Vendor's signature on its bid, or on the certification and signature page, constitutes an offer to the State that cannot be unilaterally withdrawn, signifies that the product or service proposed by vendor meets the mandatory requirements contained in the Solicitation for that product or service, unless otherwise indicated, and signifies acceptance of the terms and conditions contained in the Solicitation unless otherwise indicated.

**13. PRICING:** The pricing set forth herein is firm for the life of the Contract, unless specified elsewhere within this Solicitation/Contract by the State. A Vendor's inclusion of price adjustment provisions in its bid, without an express authorization from the State in the Solicitation to do so, may result in bid disqualification.

**14. PAYMENT:** Payment in advance is prohibited under this Contract. Payment may only be made after the delivery and acceptance of goods or services. The Vendor shall submit invoices, in arrears.

**15. PURCHASING CARD ACCEPTANCE:** The State of West Virginia currently utilizes a Purchasing Card program, administered under contract by a banking institution, to process payment for goods and services. The Vendor must accept the State of West Virginia's Purchasing Card for payment of all orders under this Contract unless the box below is checked.

Vendor is not required to accept the State of West Virginia's Purchasing Card as payment for all goods and services.

**16. TAXES:** The Vendor shall pay any applicable sales, use, personal property or any other taxes arising out of this Contract and the transactions contemplated thereby. The State of West Virginia is exempt from federal and state taxes and will not pay or reimburse such taxes.

**17. ADDITIONAL FEES:** Vendor is not permitted to charge additional fees or assess additional charges that were not either expressly provided for in the solicitation published by the State of West Virginia or included in the unit price or lump sum bid amount that Vendor is required by the solicitation to provide. Including such fees or charges as notes to the solicitation may result in rejection of vendor's bid. Requesting such fees or charges be paid after the contract has been awarded may result in cancellation of the contract.

**18. FUNDING:** This Contract shall continue for the term stated herein, contingent upon funds being appropriated by the Legislature or otherwise being made available. In the event funds are not appropriated or otherwise made available, this Contract becomes void and of no effect beginning on July 1 of the fiscal year for which funding has not been appropriated or otherwise made available.

**19. CANCELLATION:** The Purchasing Division Director reserves the right to cancel this Contract immediately upon written notice to the vendor if the materials or workmanship supplied do not conform to the specifications contained in the Contract. The Purchasing Division Director may also cancel any purchase or Contract upon 30 days written notice to the Vendor in accordance with West Virginia Code of State Rules § 148-1-5.2.b.

**20. TIME:** Time is of the essence with regard to all matters of time and performance in this Contract.

**21. APPLICABLE LAW:** This Contract is governed by and interpreted under West Virginia law without giving effect to its choice of law principles. Any information provided in specification manuals, or any other source, verbal or written, which contradicts or violates the West Virginia Constitution, West Virginia Code or West Virginia Code of State Rules is void and of no effect.

**22. COMPLIANCE WITH LAWS:** Vendor shall comply with all applicable federal, state, and local laws, regulations and ordinances. By submitting a bid, Vendor acknowledges that it has reviewed, understands, and will comply with all applicable laws, regulations, and ordinances.

**SUBCONTRACTOR COMPLIANCE:** Vendor shall notify all subcontractors providing commodities or services related to this Contract that as subcontractors, they too are required to comply with all applicable laws, regulations, and ordinances. Notification under this provision must occur prior to the performance of any work under the contract by the subcontractor.

**23. ARBITRATION:** Any references made to arbitration contained in this Contract, Vendor's bid, or in any American Institute of Architects documents pertaining to this Contract are hereby deleted, void, and of no effect.

**24. MODIFICATIONS:** This writing is the parties' final expression of intent. Notwithstanding anything contained in this Contract to the contrary no modification of this Contract shall be binding without mutual written consent of the Agency, and the Vendor, with approval of the Purchasing Division and the Attorney General's office (Attorney General approval is as to form only). Any change to existing contracts that adds work or changes contract cost, and were not included in the original contract, must be approved by the Purchasing Division and the Attorney General's Office (as to form) prior to the implementation of the change or commencement of work affected by the change.

**25. WAIVER:** The failure of either party to insist upon a strict performance of any of the terms or provision of this Contract, or to exercise any option, right, or remedy herein contained, shall not be construed as a waiver or a relinquishment for the future of such term, provision, option, right, or remedy, but the same shall continue in full force and effect. Any waiver must be expressly stated in writing and signed by the waiving party.

**26. SUBSEQUENT FORMS:** The terms and conditions contained in this Contract shall supersede any and all subsequent terms and conditions which may appear on any form documents submitted by Vendor to the Agency or Purchasing Division such as price lists, order forms, invoices, sales agreements, or maintenance agreements, and includes internet websites or other electronic documents. Acceptance or use of Vendor's forms does not constitute acceptance of the terms and conditions contained thereon.

**27. ASSIGNMENT:** Neither this Contract nor any monies due, or to become due hereunder, may be assigned by the Vendor without the express written consent of the Agency, the Purchasing Division, the Attorney General's office (as to form only), and any other government agency or office that may be required to approve such assignments. Notwithstanding the foregoing, Purchasing Division approval may or may not be required on certain agency delegated or exempt purchases.

**28. WARRANTY:** The Vendor expressly warrants that the goods and/or services covered by this Contract will: (a) conform to the specifications, drawings, samples, or other description furnished or specified by the Agency; (b) be merchantable and fit for the purpose intended; and (c) be free from defect in material and workmanship.

**29. STATE EMPLOYEES:** State employees are not permitted to utilize this Contract for personal use and the Vendor is prohibited from permitting or facilitating the same.

**30. BANKRUPTCY:** In the event the Vendor files for bankruptcy protection, the State of West Virginia may deem this Contract null and void, and terminate this Contract without notice.

**31. PRIVACY, SECURITY, AND CONFIDENTIALITY:** The Vendor agrees that it will not disclose to anyone, directly or indirectly, any such personally identifiable information or other confidential information gained from the Agency, unless the individual who is the subject of the information consents to the disclosure in writing or the disclosure is made pursuant to the Agency's policies, procedures, and rules. Vendor further agrees to comply with the Confidentiality Policies and Information Security Accountability Requirements, set forth in <http://www.state.wv.us/admin/purchase/privacy/default.html>.

**32. YOUR SUBMISSION IS A PUBLIC DOCUMENT:** Vendor's entire response to the Solicitation and the resulting Contract are public documents. As public documents, they will be disclosed to the public following the bid/proposal opening or award of the contract, as required by the competitive bidding laws of West Virginia Code §§ 5A-3-1 et seq., 5-22-1 et seq., and 5G-1-1 et seq. and the Freedom of Information Act West Virginia Code §§ 29B-1-1 et seq.

**DO NOT SUBMIT MATERIAL YOU CONSIDER TO BE CONFIDENTIAL, A TRADE SECRET, OR OTHERWISE NOT SUBJECT TO PUBLIC DISCLOSURE.**

Submission of any bid, proposal, or other document to the Purchasing Division constitutes your explicit consent to the subsequent public disclosure of the bid, proposal, or document. The Purchasing Division will disclose any document labeled "confidential," "proprietary," "trade secret," "private," or labeled with any other claim against public disclosure of the documents, to include any "trade secrets" as defined by West Virginia Code § 47-22-1 et seq. All submissions are subject to public disclosure without notice.

**33. LICENSING:** In accordance with West Virginia Code of State Rules § 148-1-6.1.e, Vendor must be licensed and in good standing in accordance with any and all state and local laws and requirements by any state or local agency of West Virginia, including, but not limited to, the West Virginia Secretary of State's Office, the West Virginia Tax Department, West Virginia Insurance Commission, or any other state agency or political subdivision. Obligations related to political subdivisions may include, but are not limited to, business licensing, business and occupation taxes, inspection compliance, permitting, etc. Upon request, the Vendor must provide all necessary releases to obtain information to enable the Purchasing Division Director or the Agency to verify that the Vendor is licensed and in good standing with the above entities.

**SUBCONTRACTOR COMPLIANCE:** Vendor shall notify all subcontractors providing commodities or services related to this Contract that as subcontractors, they too are required to be licensed, in good standing, and up-to-date on all state and local obligations as described in this section. Obligations related to political subdivisions may include, but are not limited to, business licensing, business and occupation taxes, inspection compliance, permitting, etc. Notification under this provision must occur prior to the performance of any work under the contract by the subcontractor.

**34. ANTITRUST:** In submitting a bid to, signing a contract with, or accepting a Award Document from any agency of the State of West Virginia, the Vendor agrees to convey, sell, assign, or transfer to the State of West Virginia all rights, title, and interest in and to all causes of action it may now or hereafter acquire under the antitrust laws of the United States and the State of West Virginia for price fixing and/or unreasonable restraints of trade relating to the particular commodities or services purchased or acquired by the State of West Virginia. Such assignment shall be made and become effective at the time the purchasing agency tenders the initial payment to Vendor.

**35. VENDOR CERTIFICATIONS:** By signing its bid or entering into this Contract, Vendor certifies (1) that its bid or offer was made without prior understanding, agreement, or connection with any corporation, firm, limited liability company, partnership, person or entity submitting a bid or offer for the same material, supplies, equipment or services; (2) that its bid or offer is in all respects fair and without collusion or fraud; (3) that this Contract is accepted or entered into without any prior understanding, agreement, or connection to any other entity that could be considered a violation of law; and (4) that it has reviewed this Solicitation in its entirety; understands the requirements, terms and conditions, and other information contained herein.

Vendor's signature on its bid or offer also affirms that neither it nor its representatives have any interest, nor shall acquire any interest, direct or indirect, which would compromise the performance of its services hereunder. Any such interests shall be promptly presented in detail to the Agency. The individual signing this bid or offer on behalf of Vendor certifies that he or she is authorized by the Vendor to execute this bid or offer or any documents related thereto on Vendor's behalf; that he or she is authorized to bind the Vendor in a contractual relationship; and that, to the best of his or her knowledge, the Vendor has properly registered with any State agency that may require registration.

**36. VENDOR RELATIONSHIP:** The relationship of the Vendor to the State shall be that of an independent contractor and no principal-agent relationship or employer-employee relationship is contemplated or created by this Contract. The Vendor as an independent contractor is solely liable for the acts and omissions of its employees and agents. Vendor shall be responsible for selecting, supervising, and compensating any and all individuals employed pursuant to the terms of this Solicitation and resulting contract. Neither the Vendor, nor any employees or subcontractors of the Vendor, shall be deemed to be employees of the State for any purpose whatsoever. Vendor shall be exclusively responsible for payment of employees and contractors for all wages and salaries, taxes, withholding payments, penalties, fees, fringe benefits, professional liability insurance premiums, contributions to insurance and pension, or other deferred compensation plans, including but not limited to, Workers' Compensation and Social Security obligations, licensing fees, etc. and the filing of all necessary documents, forms, and returns pertinent to all of the foregoing.

Vendor shall hold harmless the State, and shall provide the State and Agency with a defense against any and all claims including, but not limited to, the foregoing payments, withholdings, contributions, taxes, Social Security taxes, and employer income tax returns.

**37. INDEMNIFICATION:** The Vendor agrees to indemnify, defend, and hold harmless the State and the Agency, their officers, and employees from and against: (1) Any claims or losses for services rendered by any subcontractor, person, or firm performing or supplying services, materials, or supplies in connection with the performance of the Contract; (2) Any claims or losses resulting to any person or entity injured or damaged by the Vendor, its officers, employees, or subcontractors by the publication, translation, reproduction, delivery, performance, use, or disposition of any data used under the Contract in a manner not authorized by the Contract, or by Federal or State statutes or regulations; and (3) Any failure of the Vendor, its officers, employees, or subcontractors to observe State and Federal laws including, but not limited to, labor and wage and hour laws.

**38. PURCHASING AFFIDAVIT:** In accordance with West Virginia Code § 5-22-1(i), the contracting public entity shall not award a contract for a construction project to any bidder that is known to be in default on any monetary obligation owed to the state or a political subdivision of the state, including, but not limited to, obligations related to payroll taxes, property taxes, sales and use taxes, fire service fees, or other fines or fees. Accordingly, prior to contract award, Vendors are required to sign, notarize, and submit the Purchasing Affidavit to the Purchasing Division affirming under oath that it is not in default on any monetary obligation owed to the state or a political subdivision of the state.

**39. ADDITIONAL AGENCY AND LOCAL GOVERNMENT USE:** This Contract may be utilized by other agencies, spending units, and political subdivisions of the State of West Virginia; county, municipal, and other local government bodies; and school districts (“Other Government Entities”). Any extension of this Contract to the aforementioned Other Government Entities must be on the same prices, terms, and conditions as those offered and agreed to in this Contract, provided that such extension is in compliance with the applicable laws, rules, and ordinances of the Other Government Entity. If the Vendor does not wish to extend the prices, terms, and conditions of its bid and subsequent contract to the Other Government Entities, the Vendor must clearly indicate such refusal in its bid. A refusal to extend this Contract to the Other Government Entities shall not impact or influence the award of this Contract in any manner.

**40. CONFLICT OF INTEREST:** Vendor, its officers or members or employees, shall not presently have or acquire an interest, direct or indirect, which would conflict with or compromise the performance of its obligations hereunder. Vendor shall periodically inquire of its officers, members and employees to ensure that a conflict of interest does not arise. Any conflict of interest discovered shall be promptly presented in detail to the Agency.

**41. REPORTS:** Vendor shall provide the Agency and/or the Purchasing Division with the following reports identified by a checked box below:

Such reports as the Agency and/or the Purchasing Division may request. Requested reports may include, but are not limited to, quantities purchased, agencies utilizing the contract, total contract expenditures by agency, etc.

Quarterly reports detailing the total quantity of purchases in units and dollars, along with a listing of purchases by agency. Quarterly reports should be delivered to the Purchasing Division via email at [purchasing.requisitions@wv.gov](mailto:purchasing.requisitions@wv.gov).

**42. BACKGROUND CHECK:** In accordance with W. Va. Code § 15-2D-3, the Director of the Division of Protective Services shall require any service provider whose employees are regularly employed on the grounds or in the buildings of the Capitol complex or who have access to sensitive or critical information to submit to a fingerprint-based state and federal background inquiry through the state repository. The service provider is responsible for any costs associated with the fingerprint-based state and federal background inquiry.

After the contract for such services has been approved, but before any such employees are permitted to be on the grounds or in the buildings of the Capitol complex or have access to sensitive or critical information, the service provider shall submit a list of all persons who will be physically present and working at the Capitol complex to the Director of the Division of



Protective Services for purposes of verifying compliance with this provision. The State reserves the right to prohibit a service provider's employees from accessing sensitive or critical information or to be present at the Capitol complex based upon results addressed from a criminal background check.

Service providers should contact the West Virginia Division of Protective Services by phone at (304) 558-9911 for more information.

**43. PREFERENCE FOR USE OF DOMESTIC STEEL PRODUCTS:** Except when authorized by the Director of the Purchasing Division pursuant to W. Va. Code § 5A-3-56, no contractor may use or supply steel products for a State Contract Project other than those steel products made in the United States. A contractor who uses steel products in violation of this section may be subject to civil penalties pursuant to W. Va. Code § 5A-3-56. As used in this section:

- a. "State Contract Project" means any erection or construction of, or any addition to, alteration of or other improvement to any building or structure, including, but not limited to, roads or highways, or the installation of any heating or cooling or ventilating plants or other equipment, or the supply of and materials for such projects, pursuant to a contract with the State of West Virginia for which bids were solicited on or after June 6, 2001.
- b. "Steel Products" means products rolled, formed, shaped, drawn, extruded, forged, cast, fabricated or otherwise similarly processed, or processed by a combination of two or more or such operations, from steel made by the open heath, basic oxygen, electric furnace, Bessemer or other steel making process. The Purchasing Division Director may, in writing, authorize the use of foreign steel products if:
- c. The cost for each contract item used does not exceed one tenth of one percent (.1%) of the total contract cost or two thousand five hundred dollars (\$2,500.00), whichever is greater. For the purposes of this section, the cost is the value of the steel product as delivered to the project; or
- d. The Director of the Purchasing Division determines that specified steel materials are not produced in the United States in sufficient quantity or otherwise are not reasonably available to meet contract requirements.

**44. PREFERENCE FOR USE OF DOMESTIC ALUMINUM, GLASS, AND STEEL:** In Accordance with W. Va. Code § 5-19-1 et seq., and W. Va. CSR § 148-10-1 et seq., for every contract or subcontract, subject to the limitations contained herein, for the construction, reconstruction, alteration, repair, improvement or maintenance of public works or for the purchase of any item of machinery or equipment to be used at sites of public works, only domestic aluminum, glass or steel products shall be supplied unless the spending officer determines, in writing, after the receipt of offers or bids, (1) that the cost of domestic aluminum, glass or steel products is unreasonable or inconsistent with the public interest of the State of West Virginia, (2) that domestic aluminum, glass or steel products are not produced in sufficient quantities to meet the contract requirements, or (3) the available domestic aluminum, glass, or steel do not meet the contract specifications. This provision only applies to public works contracts awarded in an amount more than fifty thousand dollars (\$50,000) or public works contracts that require more than ten thousand pounds of steel products.

The cost of domestic aluminum, glass, or steel products may be unreasonable if the cost is more than twenty percent (20%) of the bid or offered price for foreign made aluminum, glass, or steel products. If the domestic aluminum, glass or steel products to be supplied or produced in a “substantial labor surplus area”, as defined by the United States Department of Labor, the cost of domestic aluminum, glass, or steel products may be unreasonable if the cost is more than thirty percent (30%) of the bid or offered price for foreign made aluminum, glass, or steel products. This preference shall be applied to an item of machinery or equipment, as indicated above, when the item is a single unit of equipment or machinery manufactured primarily of aluminum, glass or steel, is part of a public works contract and has the sole purpose or of being a permanent part of a single public works project. This provision does not apply to equipment or machinery purchased by a spending unit for use by that spending unit and not as part of a single public works project.

All bids and offers including domestic aluminum, glass or steel products that exceed bid or offer prices including foreign aluminum, glass or steel products after application of the preferences provided in this provision may be reduced to a price equal to or lower than the lowest bid or offer price for foreign aluminum, glass or steel products plus the applicable preference. If the reduced bid or offer prices are made in writing and supersede the prior bid or offer prices, all bids or offers, including the reduced bid or offer prices, will be reevaluated in accordance with this rule.

**45. INTERESTED PARTY SUPPLEMENTAL DISCLOSURE:** W. Va. Code § 6D-1-2 requires that for contracts with an actual or estimated value of at least \$100,000, the vendor must submit to the Agency a supplemental disclosure of interested parties reflecting any new or differing interested parties to the contract, which were not included in the original pre-award interested party disclosure, within 30 days following the completion or termination of the contract. A copy of that form is included with this solicitation or can be obtained from the WV Ethics Commission. "Interested parties" means: (1) A business entity performing work or service pursuant to, or in furtherance of, the applicable contract, including specifically sub-contractors; (2) the person(s) who have an ownership interest equal to or greater than 25% in the business entity performing work or service pursuant to, or in furtherance of, the applicable contract; and (3) the person or business entity, if any, that served as a compensated broker or intermediary to actively facilitate the applicable contract or negotiated the terms of the applicable contract with the state agency: Provided, That subdivision (2) shall be inapplicable if a business entity is a publicly traded company: Provided, however, That subdivision (3) shall not include persons or business entities performing legal services related to the negotiation or drafting of the applicable contract. The Agency shall submit a copy of the disclosure to the Ethics Commission within 15 days after receiving the supplemental disclosure of interested parties.

**DESIGNATED CONTACT:** Vendor appoints the individual identified in this Section as the Contract Administrator and the initial point of contact for matters relating to this Contract.

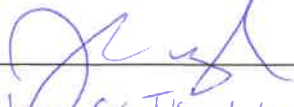
  
\_\_\_\_\_  
(Name, Title)  
Jennifer Treadway Bidding Agent / Sales  
\_\_\_\_\_  
(Printed Name and Title)  
PO Box 914 Logan Oh 43138  
\_\_\_\_\_  
(Address)  
800-523-8917 Fax 740-385-8016  
\_\_\_\_\_  
(Phone Number) / (Fax Number)  
jennifert@osburns.com  
\_\_\_\_\_  
(email address)

**CERTIFICATION AND SIGNATURE:** By signing below, or submitting documentation through wvOASIS, I certify that I have reviewed this Solicitation in its entirety; that I understand the requirements, terms and conditions, and other information contained herein; that this bid, offer or proposal constitutes an offer to the State that cannot be unilaterally withdrawn; that the product or service proposed meets the mandatory requirements contained in the Solicitation for that product or service, unless otherwise stated herein; that the Vendor accepts the terms and conditions contained in the Solicitation, unless otherwise stated herein; that I am submitting this bid, offer or proposal for review and consideration; that I am authorized by the vendor to execute and submit this bid, offer, or proposal, or any documents related thereto on vendor's behalf; that I am authorized to bind the vendor in a contractual relationship; and that to the best of my knowledge, the vendor has properly registered with any State agency that may require registration.

Osburn Associates Inc  
\_\_\_\_\_  
(Company)

 Bidding Agent  
\_\_\_\_\_  
(Authorized Signature) (Representative Name, Title)

Melinda Thompson  
\_\_\_\_\_  
(Printed Name and Title of Authorized Representative)

4-20-18  
\_\_\_\_\_  
(Date)

800-523-8917 | 740-385-8016 fax  
\_\_\_\_\_  
(Phone Number) (Fax Number)

CRFQ 0803 DOT1800000085

# EXHIBIT B

## (NEXT 12 PAGES)

**EXHIBIT B**

ITEM NUMBER	DESCRIPTION	PUNCHING DETAIL*	ESTIMATED WEIGHT PER UNIT (POUNDS)	MAX SHEETS / BLANKS PER STACK	DOH INVENTORY SUBCODE
<b>CLASS II SHEET - 0.080 INCH THICKNESS</b>					
1	1-1/2 FT X 12 FT X 0.080 GAUGE THICKNESS	NO HOLES	20	2000 #	030-218144
2	2 FT X 12 FT X 0.080 GAUGE THICKNESS	NO HOLES	27	2000 #	224144
3	2-1/2 FT X 12 FT X 0.080 GAUGE THICKNESS	NO HOLES	34	2000 #	230144
4	3 FT X 12 FT X 0.080 GAUGE THICKNESS	NO HOLES	40	2000 #	236144
5	3-1/2 FT X 12 FT X 0.080 GAUGE THICKNESS	NO HOLES	47	2000 #	242144
6	4 FT X 12 FT X 0.080 GAUGE THICKNESS	NO HOLES	54	2000 #	248144
7	5 FT X 12 FT X 0.080 GAUGE THICKNESS	NO HOLES	67	2000 #	260144
<b>CLASS II SHEET - 0.040 INCH THICKNESS</b>					
8	4 FT X 12 FT X 0.040 GAUGE THICKNESS	NO HOLES	27	2000 #	148144
9	5 FT X 12 FT X 0.040 GAUGE THICKNESS	NO HOLES	34	2000 #	160144
<b>CLASS III - ALUMINUM PRE-CUT SIGN MATERIAL - 0.080 INCH THICKNESS</b>					
10	6 IN X 30 IN HORIZONTAL RECTANGLE	TP1-3	1	500 EA.	031-000630
11	9 IN X 24 IN VERTICAL RECTANGLE	TP1-4	2	500 EA.	031-000924
12	9 IN X 30 IN VERTICAL RECTANGLE	TP1-4	2	500 EA.	000930
13	9 IN X 30 IN HORIZONTAL RECTANGLE	TP1-3	2	500 EA.	000930
14	9 IN X 42 IN HORIZONTAL RECTANGLE	TP1-3 (FOLLOW D16-1 DETAIL)	3	500 EA.	000942
15	9 IN X 48 IN HORIZONTAL RECTANGLE	TP1-3 (FOLLOW D16-1 DETAIL)	3	500 EA.	000948
16	12 IN X 18 IN VERTICAL RECTANGLE	TP1-4	2	500 EA.	001218
17	12 IN X 24 IN HORIZONTAL RECTANGLE	TP1-3	2	500 EA.	001224
18	12 IN X 30 IN HORIZONTAL RECTANGLE	SPECIAL DETAIL	3	500 EA.	001230
19	12 IN X 36 IN RECTANGLE	SPECIAL DETAIL	3	500 EA.	001236
20	12 IN X 48 IN VERTICAL RECTANGLE	TP1-4	4	250 EA.	001248
21	15 IN X 21 IN HORIZONTAL RECTANGLE	TP1-3	2	500 EA.	001521
22	15 IN X 30 IN HORIZONTAL RECTANGLE	TP1-3	4	500 EA.	001530
23	15 IN X 36 IN HORIZONTAL RECTANGLE	TP1-3	4	250 EA.	001536
24	15 IN X 42 IN HORIZONTAL RECTANGLE	TP1-3	5	250 EA.	031-001542
25	15 IN X 48 IN HORIZONTAL RECTANGLE	TP1-3	6	250 EA.	001548
26	15 IN X 54 IN HORIZONTAL RECTANGLE	TP1-3	6	250 EA.	001554
27	15 IN X 60 IN HORIZONTAL RECTANGLE	TP1-3	7	250 EA.	001560

\* TP1-1 : SEE WVDOH STANDARD DETAILS BOOK, VOLUME II, PAGE TP1-1

TP1-2 : SEE WVDOH STANDARD DETAILS BOOK, VOLUME II, PAGE TP1-2

TP1-3 : SEE WVDOH STANDARD DETAILS BOOK, VOLUME II, PAGE TP1-3

TP1-4 : SEE WVDOH STANDARD DETAILS BOOK, VOLUME II, PAGE TP1-4

SPECIAL DETAIL : SEE ATTACHED SPECIAL DETAIL SHEET

FEDERAL : SEE "SIGN BLANKS" SECTION OF THE FHWA STANDARD HIGHWAY SIGNS PUBLICATION, LATEST EDITION

ITEM NUMBER	DESCRIPTION	PUNCHING DETAIL*	ESTIMATED WEIGHT PER UNIT (POUNDS)	MAX SHEETS / BLANKS PER STACK	DOH INVENTORY SUBCODE
<b>CLASS III - ALUMINUM PRE-CUT SIGN MATERIAL - 0.080 INCH THICKNESS (CONTINUED)</b>					
28	18 IN X 18 IN SQUARE	TP1-2	3	500 EA.	001818
29	18 IN X 18 IN DIAMOND	SPECIAL DETAIL	3	500 EA.	001818
30	18 IN X 24 IN VERTICAL RECTANGLE	TP1-4	3	500 EA.	001824
31	18 IN X 30 IN HORIZONTAL RECTANGLE	SPECIAL DETAIL	4	250 EA.	001830
32	18 IN X 36 IN HORIZONTAL RECTANGLE	TP1-3	5	250 EA.	001836
33	21 IN X 28 IN HORIZONTAL RECTANGLE	TP1-3	5	250 EA.	002128
34	24 IN X 24 IN SQUARE	TP1-2	4	250 EA.	002424
35	24 IN X 30 IN VERTICAL RECTANGLE	TP1-4	6	250 EA.	002430
36	24 IN X 36 IN VERTICAL RECTANGLE	SPECIAL DETAIL	7	250 EA.	002436
37	24 IN X 48 IN HORIZONTAL RECTANGLE	TP1-3	9	100 EA.	031-002448
38	24 IN X 72 IN HORIZONTAL RECTANGLE	NO HOLES	13	100 EA.	002472
39	30 IN X 30 IN DIAMOND	TP1-2	7	250 EA.	003030
40	30 IN X 30 IN SQUARE	TP1-2	7	250 EA.	003030
41	30 IN X 36 IN VERTICAL RECTANGLE	TP1-4	8	100 EA.	003036
42	30 IN X 42 IN HORIZONTAL/VERTICAL RECTANGLE	TP1-3, TP1-4 (PUNCH FOR HORIZONTAL AND VERTICAL)	10	100 EA.	003042
43	30 IN X 48 IN HORIZONTAL/VERTICAL RECTANGLE	TP1-3, TP1-4 (PUNCH FOR HORIZONTAL AND VERTICAL)	11	100 EA.	003048
44	30 IN X 60 IN HORIZONTAL RECTANGLE	TP1-3	14	100 EA.	003060
45	36 IN X 36 IN DIAMOND	TP1-2	10	100 EA.	003636
46	36 IN X 36 IN SQUARE	TP1-2	10	100 EA.	003636
47	36 IN X 45 IN HORIZONTAL RECTANGLE	TP1-3 (FOLLOW "M" SERIES DETAIL)	13	100 EA.	003645
48	36 IN X 48 IN VERTICAL RECTANGLE	TP1-4	13	100 EA.	003648
49	36 IN X 60 IN HORIZONTAL RECTANGLE	SPECIAL DETAIL	17	100 EA.	003660
50	48 IN X 48 IN DIAMOND	TP1-2	18	100 EA.	004848
51	48 IN X 60 IN VERTICAL RECTANGLE	TP1-4	22	100 EA.	004860
52	24 IN X 24 IN INTERSTATE SHIELD	FEDERAL	4	250 EA.	022424

\* TP1-1 : SEE WVDOH STANDARD DETAILS BOOK, VOLUME II, PAGE TP1-1

TP1-2 : SEE WVDOH STANDARD DETAILS BOOK, VOLUME II, PAGE TP1-2

TP1-3 : SEE WVDOH STANDARD DETAILS BOOK, VOLUME II, PAGE TP1-3

TP1-4 : SEE WVDOH STANDARD DETAILS BOOK, VOLUME II, PAGE TP1-4

SPECIAL DETAIL : SEE ATTACHED SPECIAL DETAIL SHEET

FEDERAL : SEE "SIGN BLANKS" SECTION OF THE FHWA STANDARD HIGHWAY SIGNS PUBLICATION, LATEST EDITION

ITEM NUMBER	DESCRIPTION	PUNCHING DETAIL*	ESTIMATED WEIGHT PER UNIT (POUNDS)	MAX SHEETS / BLANKS PER STACK	DOH INVENTORY SUBCODE
<b>CLASS III - ALUMINUM PRE-CUT SIGN MATERIAL - 0.080 INCH THICKNESS (CONTINUED)</b>					
53	24 IN X 30 IN INTERSTATE SHIELD	FEDERAL	6	250 EA.	031-022430
54	36 IN X 36 IN INTERSTATE SHIELD	FEDERAL	10	100 EA.	023636
55	36 IN X 45 IN INTERSTATE SHIELD	FEDERAL	13	100 EA.	023645
56	36 IN X 36 IN X 36 IN TRIANGLE	TP1-1	4	250 EA.	043636
57	48 IN X 48 IN X 48 IN TRIANGLE	TP1-1	8	250 EA.	044848
58	30 IN X 30 IN PENTAGON	FEDERAL	5	250 EA.	053030
59	36 IN X 36 IN PENTAGON	FEDERAL	8	100 EA.	053636
60	48 IN X 48 IN PENTAGON	SPECIAL DETAIL	13	100 EA.	054848
61	36 IN X 48 IN X 48 IN PENNANT	TP1-2	6	250 EA.	063648
62	48 IN X 64 IN X 64 IN PENNANT	SPECIAL DETAIL	11	100 EA.	064864
63	36 IN CIRCLE	TP1-2	8	250 EA.	073600
64	18 IN X 18 IN OCTAGON	SPECIAL DETAIL	2	500 EA.	081818
65	30 IN X 30 IN OCTAGON	TP1-1	6	250 EA.	083030
66	36 IN X 36 IN OCTAGON	TP1-1	10	100 EA.	083636
67	48 IN X 48 IN OCTAGON	TP1-1	17	100 EA.	084848
68	24 IN X 24 IN US ROUTE SHIELD	NO HOLES	4	250 EA.	022424
69	36 IN X 36 IN US ROUTE SHIELD	NO HOLES	10	100 EA.	023636
70	24 IN X 30 IN US ROUTE SHIELD	NO HOLES	6	250 EA.	022430
71	36 IN X 45 IN US ROUTE SHIELD	NO HOLES	13	100 EA.	023645

\* TP1-1 : SEE WVDOH STANDARD DETAILS BOOK, VOLUME II, PAGE TP1-1

TP1-2 : SEE WVDOH STANDARD DETAILS BOOK, VOLUME II, PAGE TP1-2

TP1-3 : SEE WVDOH STANDARD DETAILS BOOK, VOLUME II, PAGE TP1-3

TP1-4 : SEE WVDOH STANDARD DETAILS BOOK, VOLUME II, PAGE TP1-4

SPECIAL DETAIL : SEE ATTACHED SPECIAL DETAIL SHEET

FEDERAL : SEE "SIGN BLANKS" SECTION OF THE FHWA STANDARD HIGHWAY SIGNS PUBLICATION, LATEST EDITION

12 IN X 30 IN HORIZONTAL RECTANGLE

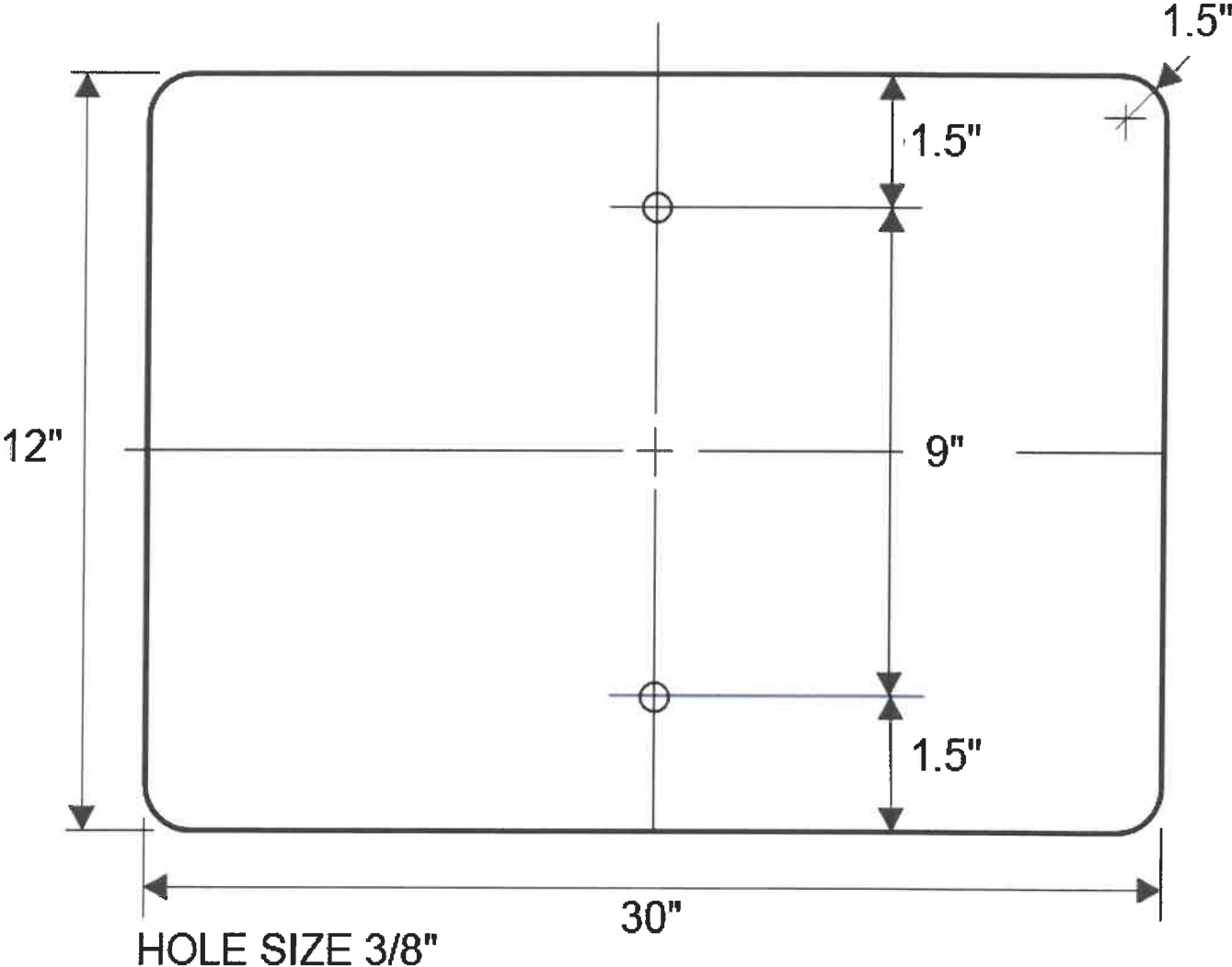



12 IN X 36 IN HORIZONTAL RECTANGLE

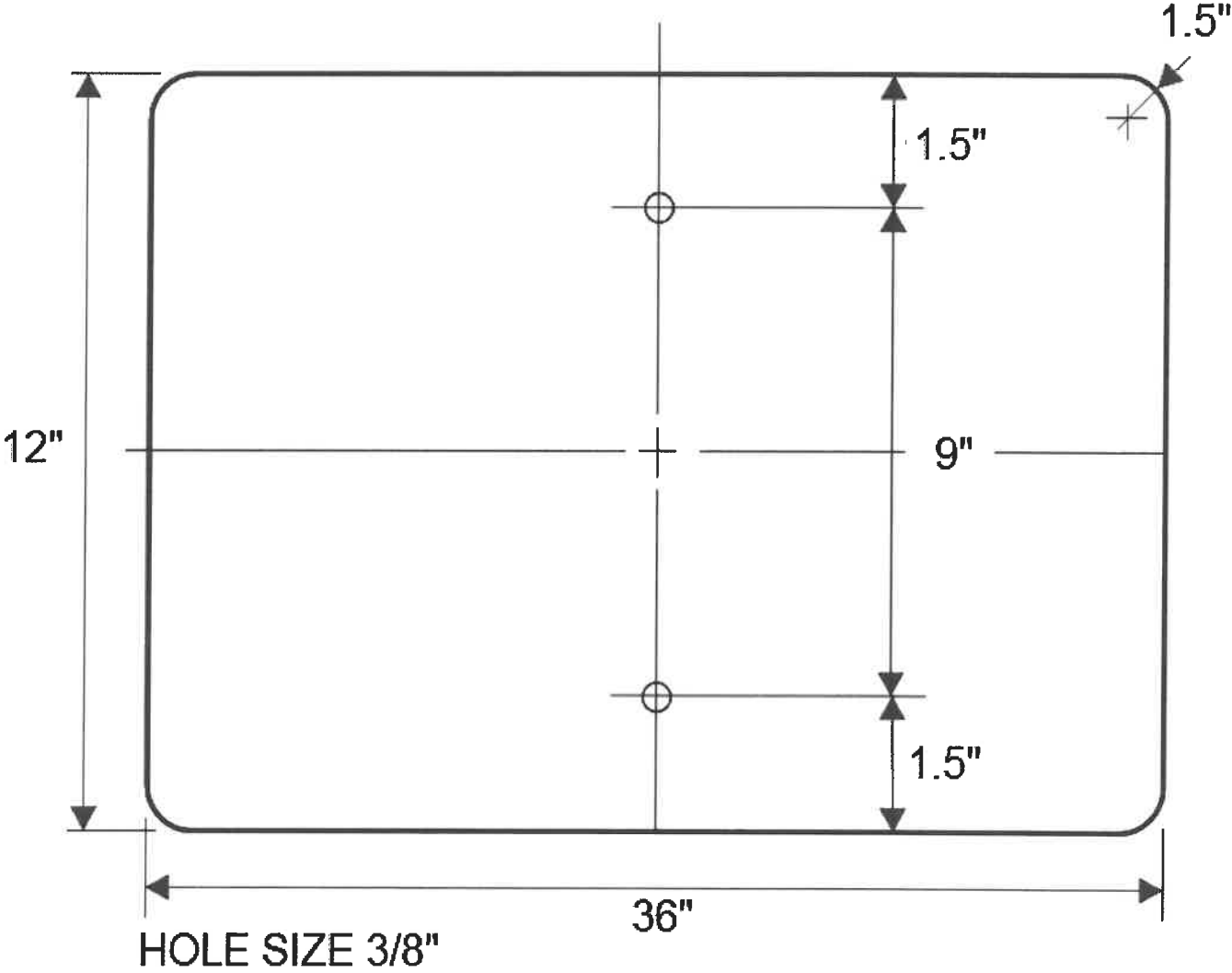

# 18 IN X 18 IN DIAMOND

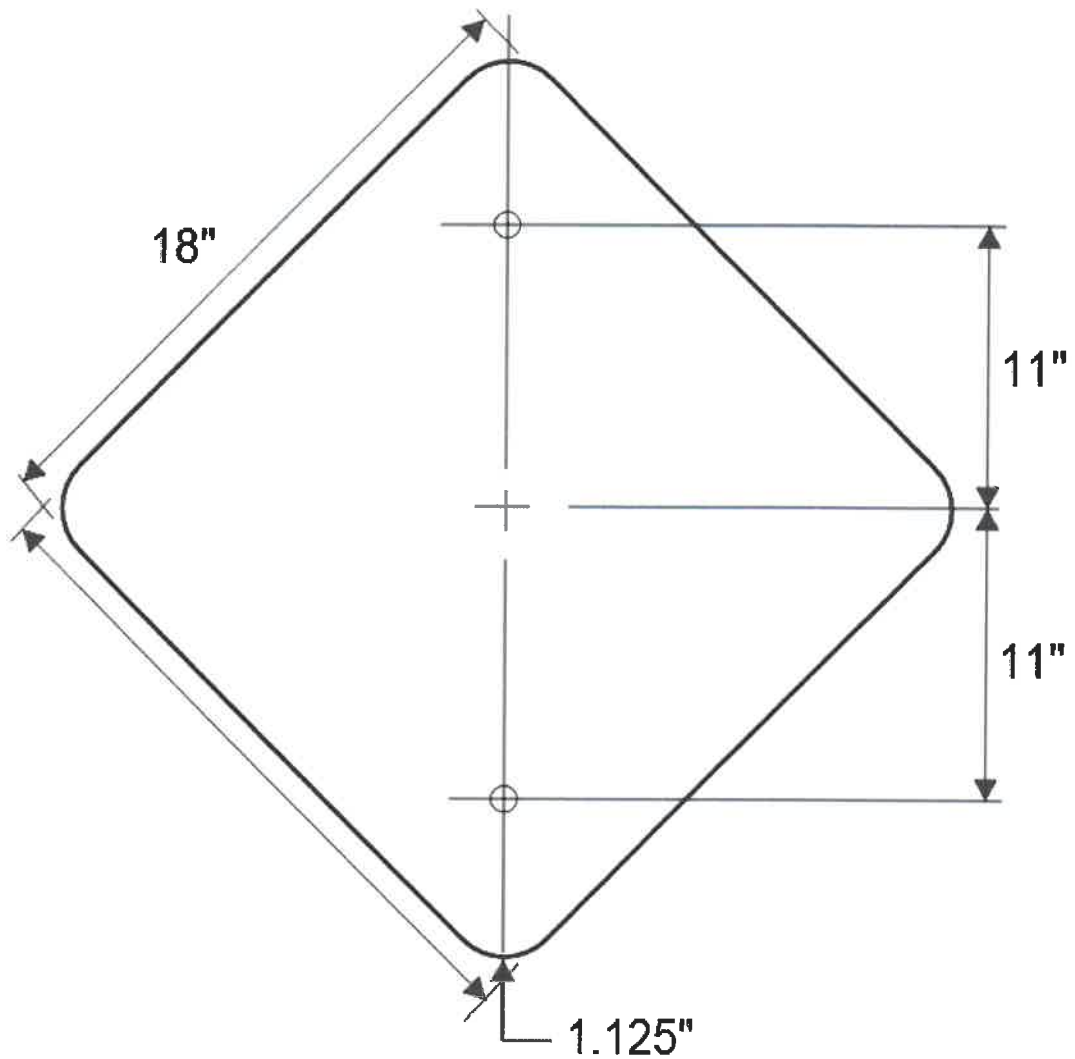

HOLE SIZE 3/8"

# 18 IN X 18 IN OCTAGON

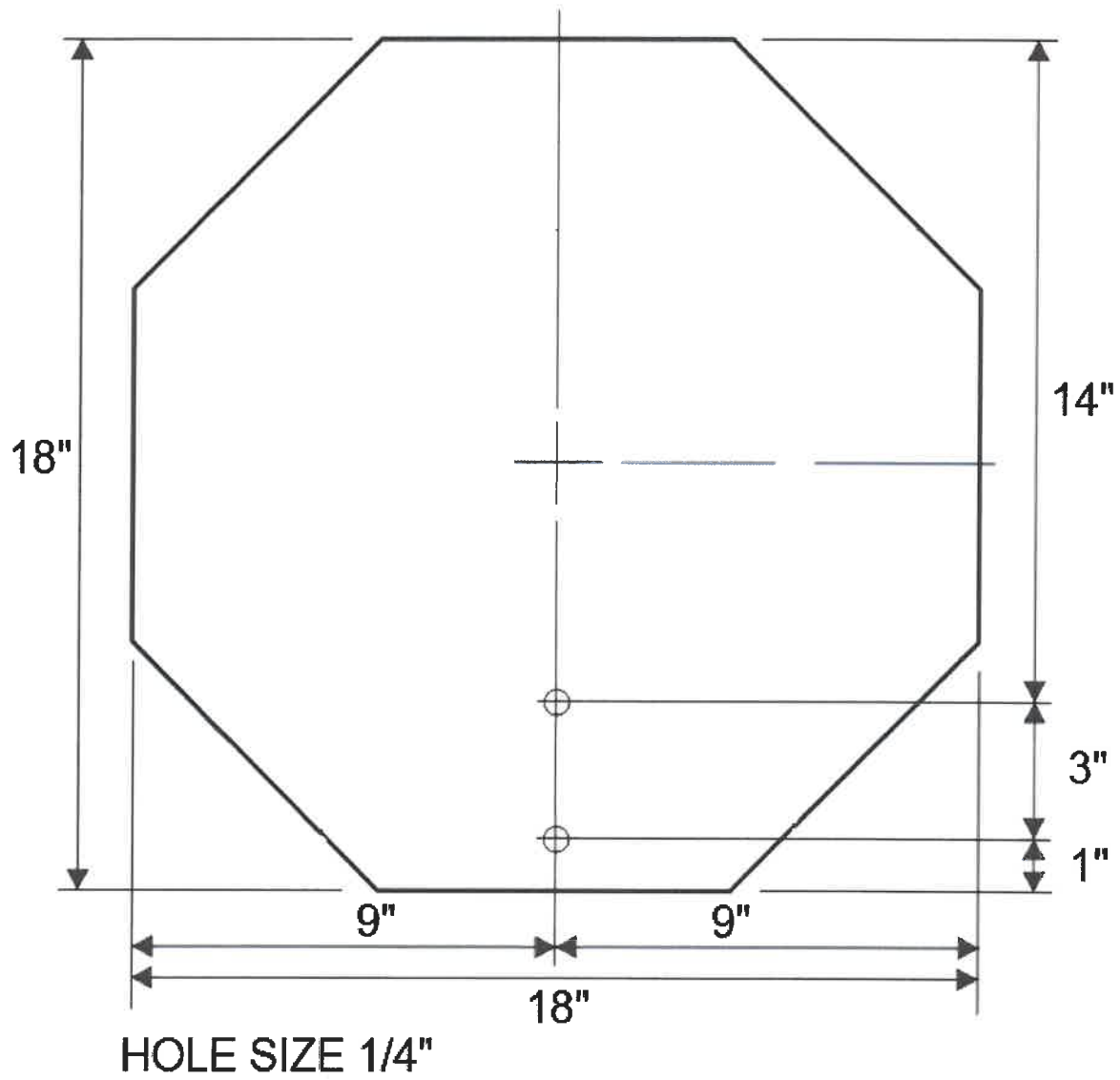

18 IN X 30 IN HORIZONTAL RECTANGLE

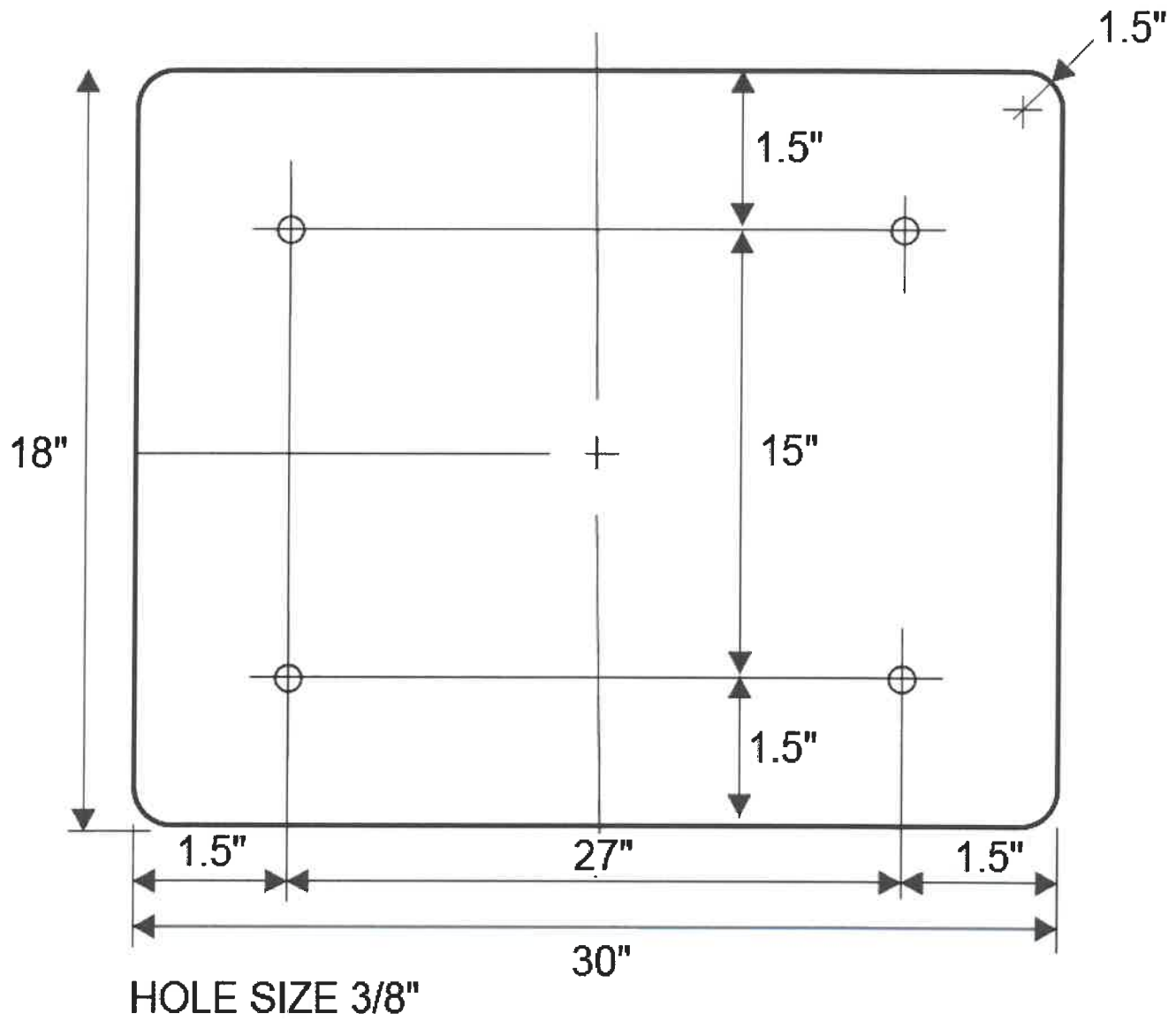

24 IN X 36 IN VERTICAL RECTANGLE

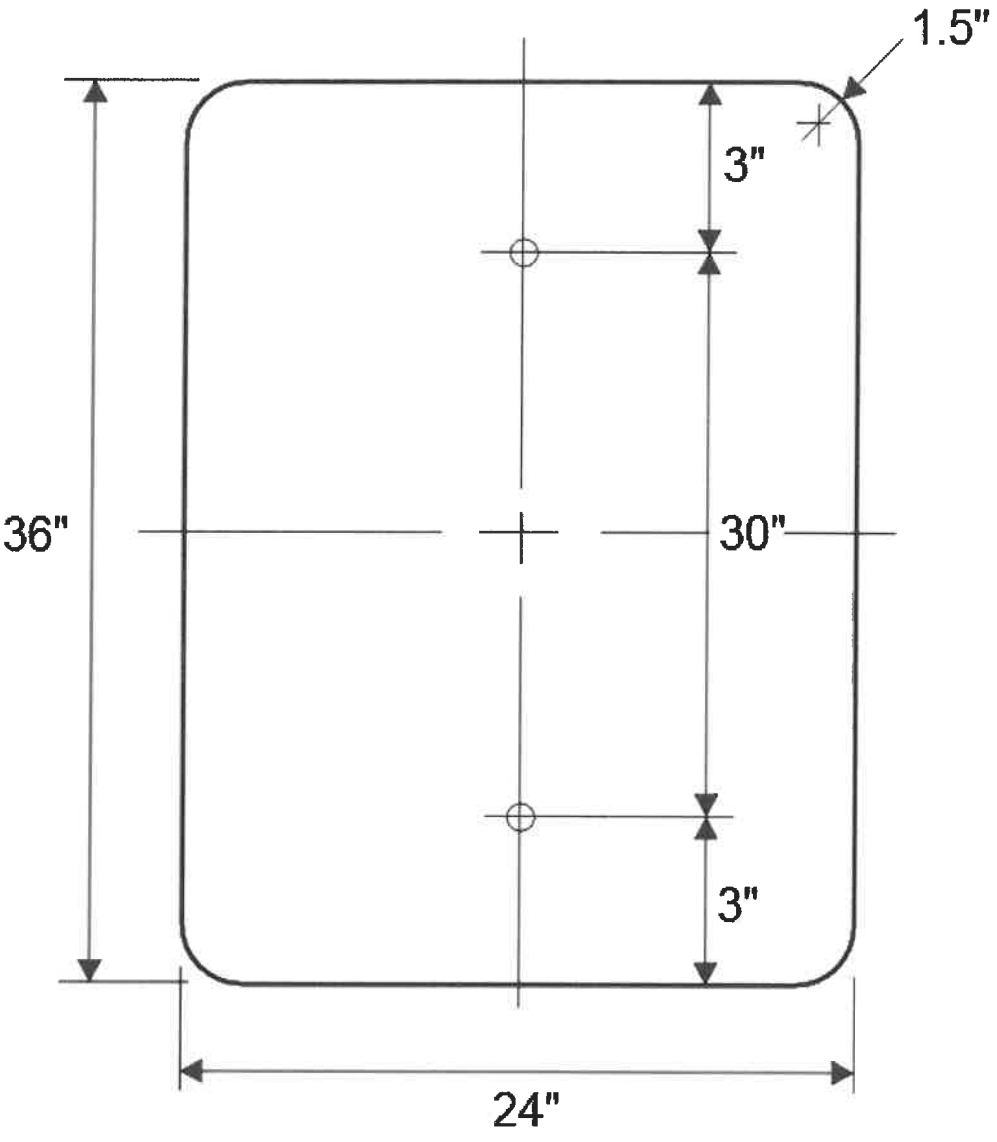

HOLE SIZE 3/8"

# 36 IN X 60 IN HORIZONTAL RECTANGLE

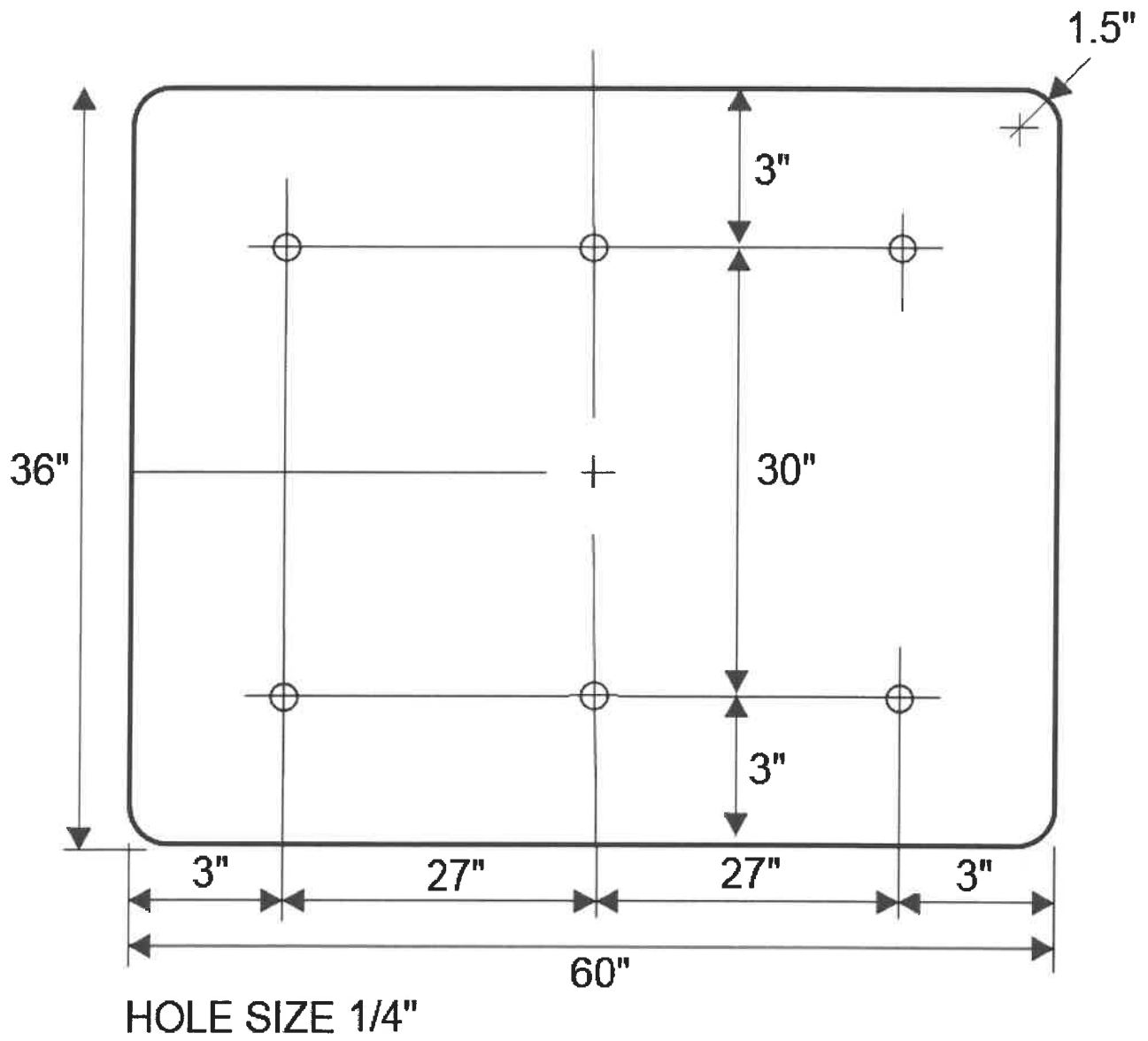

48 IN X 48 IN PENTAGON

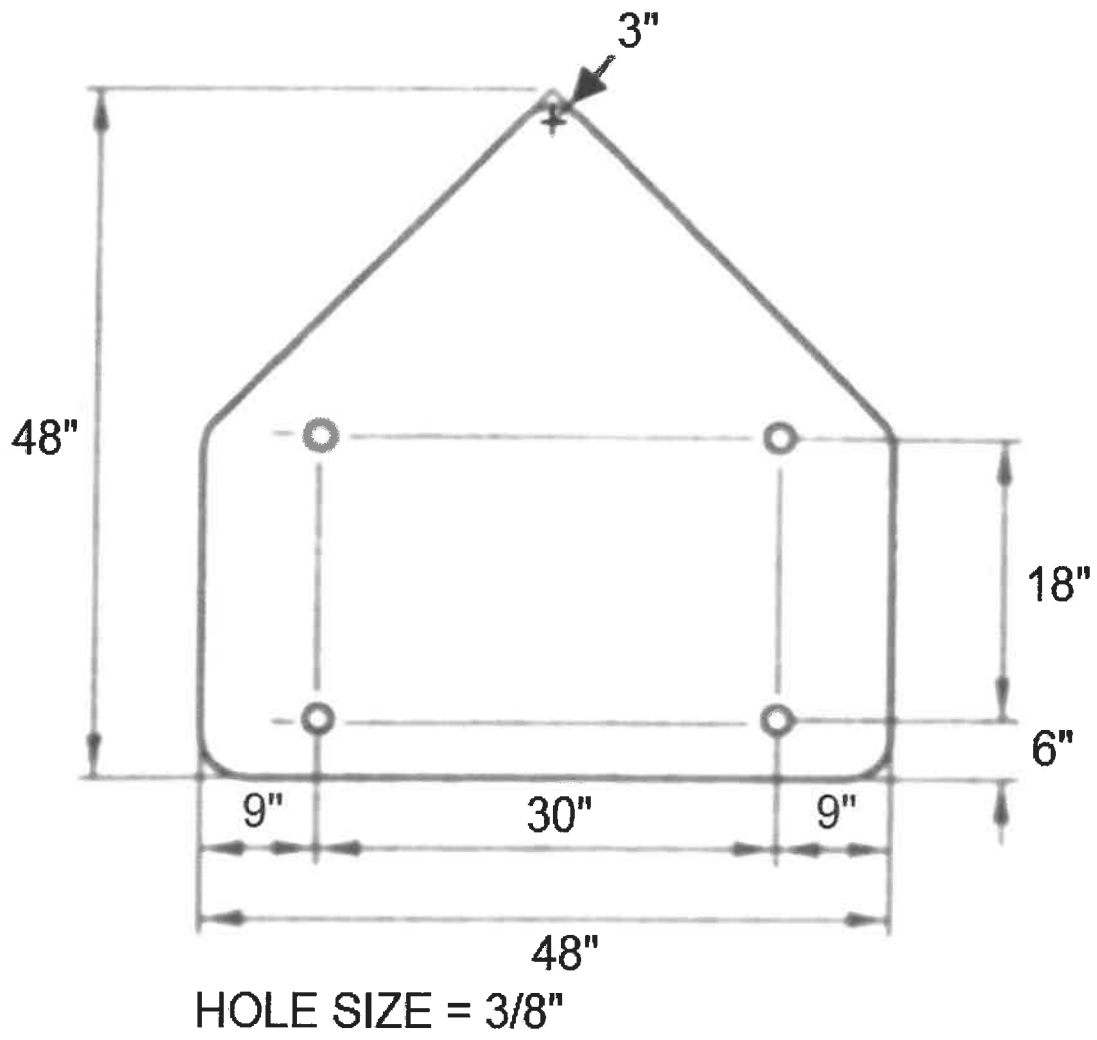

# 48 IN X 48 IN X 64 IN PENNANT

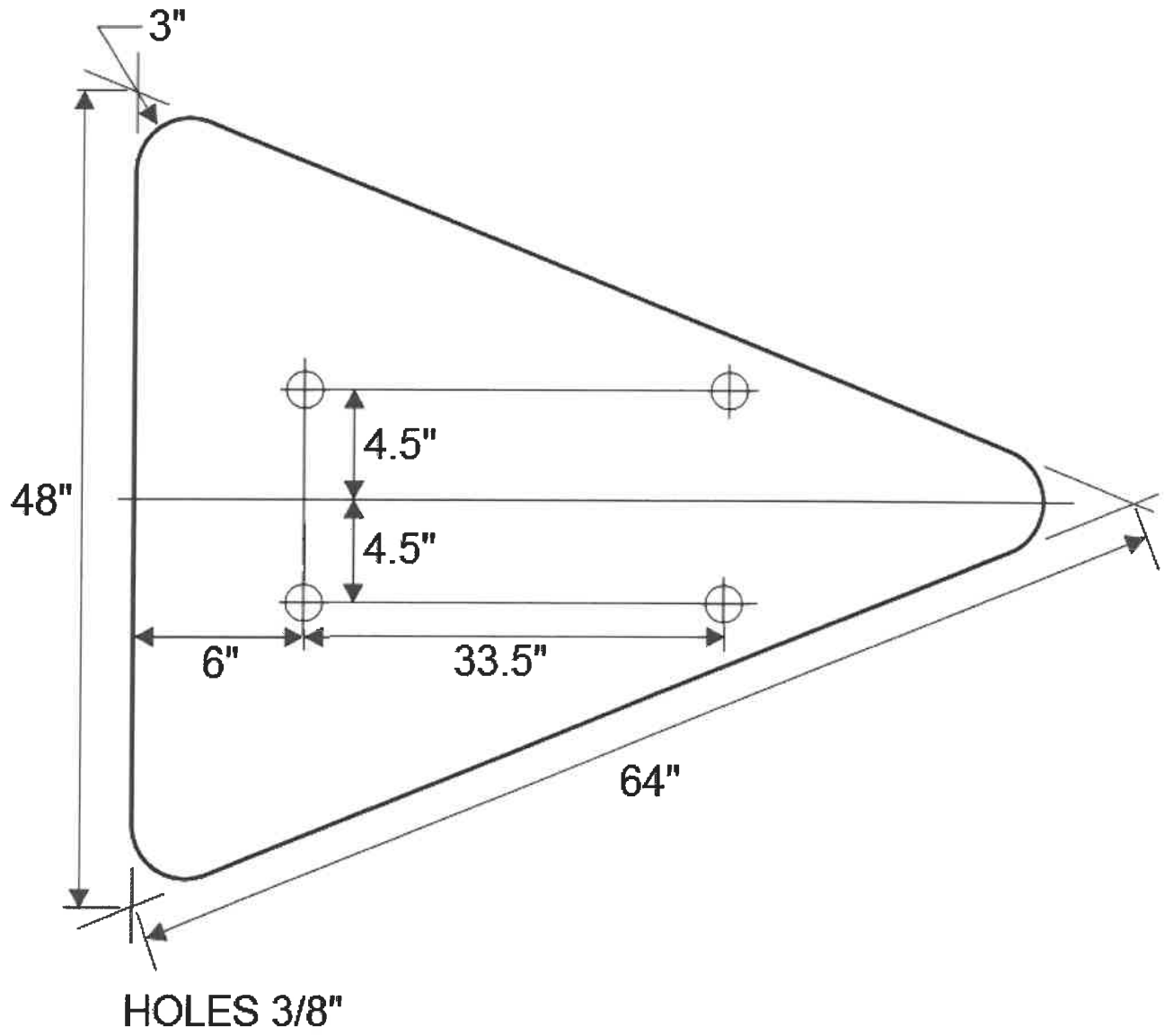



STATE OF WEST VIRGINIA  
Purchasing Division

# PURCHASING AFFIDAVIT

**CONSTRUCTION CONTRACTS:** Under W. Va. Code § 5-22-1(i), the contracting public entity shall not award a construction contract to any bidder that is known to be in default on any monetary obligation owed to the state or a political subdivision of the state, including, but not limited to, obligations related to payroll taxes, property taxes, sales and use taxes, fire service fees, or other fines or fees.

**ALL CONTRACTS:** Under W. Va. Code §5A-3-10a, no contract or renewal of any contract may be awarded by the state or any of its political subdivisions to any vendor or prospective vendor when the vendor or prospective vendor or a related party to the vendor or prospective vendor is a debtor and: (1) the debt owed is an amount greater than one thousand dollars in the aggregate; or (2) the debtor is in employer default.

**EXCEPTION:** The prohibition listed above does not apply where a vendor has contested any tax administered pursuant to chapter eleven of the W. Va. Code, workers' compensation premium, permit fee or environmental fee or assessment and the matter has not become final or where the vendor has entered into a payment plan or agreement and the vendor is not in default of any of the provisions of such plan or agreement.

**DEFINITIONS:**

**"Debt"** means any assessment, premium, penalty, fine, tax or other amount of money owed to the state or any of its political subdivisions because of a judgment, fine, permit violation, license assessment, defaulted workers' compensation premium, penalty or other assessment presently delinquent or due and required to be paid to the state or any of its political subdivisions, including any interest or additional penalties accrued thereon.

**"Employer default"** means having an outstanding balance or liability to the old fund or to the uninsured employers' fund or being in policy default, as defined in W. Va. Code § 23-2c-2, failure to maintain mandatory workers' compensation coverage, or failure to fully meet its obligations as a workers' compensation self-insured employer. An employer is not in employer default if it has entered into a repayment agreement with the Insurance Commissioner and remains in compliance with the obligations under the repayment agreement.

**"Related party"** means a party, whether an individual, corporation, partnership, association, limited liability company or any other form or business association or other entity whatsoever, related to any vendor by blood, marriage, ownership or contract through which the party has a relationship of ownership or other interest with the vendor so that the party will actually or by effect receive or control a portion of the benefit, profit or other consideration from performance of a vendor contract with the party receiving an amount that meets or exceeds five percent of the total contract amount.

**AFFIRMATION:** By signing this form, the vendor's authorized signer affirms and acknowledges under penalty of law for false swearing (W. Va. Code §61-5-3) that: (1) for construction contracts, the vendor is not in default on any monetary obligation owed to the state or a political subdivision of the state, and (2) for all other contracts, that neither vendor nor any related party owe a debt as defined above and that neither vendor nor any related party are in employer default as defined above, unless the debt or employer default is permitted under the exception above.

**WITNESS THE FOLLOWING SIGNATURE:**

Vendor's Name: Osburn Associates Inc

Authorized Signature: Melinda Thompson Date: 4-23-18

State of Ohio

County of Hocking, to-wit:

Taken, subscribed, and sworn to before me this 23rd day of April, 2018.

My Commission Expires 2/12, 2023.



MICHAEL E GROVE  
Notary Public, State of Ohio  
My Commission Expires  
February 12, 2023

NOTARY PUBLIC Michael E Grove

# VENDOR PREFERENCE CERTIFICATE

Certification and application is hereby made for Preference in accordance with **West Virginia Code**, §5A-3-37. (Does not apply to construction contracts). **West Virginia Code**, §5A-3-37, provides an opportunity for qualifying vendors to request (at the time of bid) preference for their residency status. Such preference is an evaluation method only and will be applied only to the cost bid in accordance with the **West Virginia Code**. This certificate for application is to be used to request such preference. The Purchasing Division will make the determination of the Vendor Preference, if applicable.

**1. Application is made for 2.5% vendor preference for the reason checked:**

- Bidder is an individual resident vendor and has resided continuously in West Virginia, or bidder is a partnership, association or corporation resident vendor and has maintained its headquarters or principal place of business continuously in West Virginia, for four (4) years immediately preceding the date of this certification; **or,**
- Bidder is a resident vendor partnership, association, or corporation with at least eighty percent of ownership interest of bidder held by another entity that meets the applicable four year residency requirement; **or,**
- Bidder is a nonresident vendor which has an affiliate or subsidiary which employs a minimum of one hundred state residents and which has maintained its headquarters or principal place of business within West Virginia continuously for the four (4) years immediately preceding the date of this certification; **or,**

**2. Application is made for 2.5% vendor preference for the reason checked:**

- Bidder is a resident vendor who certifies that, during the life of the contract, on average at least 75% of the employees working on the project being bid are residents of West Virginia who have resided in the state continuously for the two years immediately preceding submission of this bid; **or,**

**3. Application is made for 2.5% vendor preference for the reason checked:**

- Bidder is a nonresident vendor that employs a minimum of one hundred state residents, or a nonresident vendor which has an affiliate or subsidiary which maintains its headquarters or principal place of business within West Virginia and employs a minimum of one hundred state residents, and for purposes of producing or distributing the commodities or completing the project which is the subject of the bidder's bid and continuously over the entire term of the project, on average at least seventy-five percent of the bidder's employees or the bidder's affiliate's or subsidiary's employees are residents of West Virginia who have resided in the state continuously for the two immediately preceding years and the vendor's bid; **or,**

**4. Application is made for 5% vendor preference for the reason checked:**

- Bidder meets either the requirement of both subdivisions (1) and (2) or subdivision (1) and (3) as stated above; **or,**

**5. Application is made for 3.5% vendor preference who is a veteran for the reason checked:**

- Bidder is an individual resident vendor who is a veteran of the United States armed forces, the reserves or the National Guard and has resided in West Virginia continuously for the four years immediately preceding the date on which the bid is submitted; **or,**

**6. Application is made for 3.5% vendor preference who is a veteran for the reason checked:**

- Bidder is a resident vendor who is a veteran of the United States armed forces, the reserves or the National Guard, if, for purposes of producing or distributing the commodities or completing the project which is the subject of the vendor's bid and continuously over the entire term of the project, on average at least seventy-five percent of the vendor's employees are residents of West Virginia who have resided in the state continuously for the two immediately preceding years.

**7. Application is made for preference as a non-resident small, women- and minority-owned business, in accordance with West Virginia Code §5A-3-59 and West Virginia Code of State Rules.**

- Bidder has been or expects to be approved prior to contract award by the Purchasing Division as a certified small, women- and minority-owned business.

Bidder understands if the Secretary of Revenue determines that a Bidder receiving preference has failed to continue to meet the requirements for such preference, the Secretary may order the Director of Purchasing to: (a) rescind the contract or purchase order; or (b) assess a penalty against such Bidder in an amount not to exceed 5% of the bid amount and that such penalty will be paid to the contracting agency or deducted from any unpaid balance on the contract or purchase order.

By submission of this certificate, Bidder agrees to disclose any reasonably requested information to the Purchasing Division and authorizes the Department of Revenue to disclose to the Director of Purchasing appropriate information verifying that Bidder has paid the required business taxes, provided that such information does not contain the amounts of taxes paid nor any other information deemed by the Tax Commissioner to be confidential.

**Bidder hereby certifies that this certificate is true and accurate in all respects; and that if a contract is issued to Bidder and if anything contained within this certificate changes during the term of the contract, Bidder will notify the Purchasing Division in writing immediately.**

Bidder: Osborn Associates Inc Signed: Melinda Thomas

Date: 4-23-18 Title: Bidding Agent

\*Check any combination of preference consideration(s) indicated above, which you are entitled to receive.

## West Virginia Ethics Commission



### Disclosure of Interested Parties to Contracts

Pursuant to *W. Va. Code* § 6D-1-2, a state agency may not enter into a contract, or a series of related contracts, that has/have an actual or estimated value of \$100,000 or more until the business entity submits to the contracting state agency a Disclosure of Interested Parties to the applicable contract. In addition, the business entity awarded a contract is obligated to submit a supplemental Disclosure of Interested Parties reflecting any new or differing interested parties to the contract within 30 days following the completion or termination of the applicable contract.

For purposes of complying with these requirements, the following definitions apply:

*"Business entity"* means any entity recognized by law through which business is conducted, including a sole proprietorship, partnership or corporation.

*"Interested party"* or *"Interested parties"* means:

- (1) A business entity performing work or service pursuant to, or in furtherance of, the applicable contract, including specifically sub-contractors;
- (2) the person(s) who have an ownership interest equal to or greater than 25% in the business entity performing work or service pursuant to, or in furtherance of, the applicable contract. (This subdivision does not apply to a publicly traded company); and
- (3) the person or business entity, if any, that served as a compensated broker or intermediary to actively facilitate the applicable contract or negotiated the terms of the applicable contract with the state agency. (This subdivision does not apply to persons or business entities performing legal services related to the negotiation or drafting of the applicable contract.)

*"State agency"* means a board, commission, office, department or other agency in the executive, judicial or legislative branch of state government, including publicly funded institutions of higher education: Provided, that for purposes of *W. Va. Code* § 6D-1-2, the West Virginia Investment Management Board shall not be deemed a state agency nor subject to the requirements of that provision.

The contracting business entity must complete this form and submit it to the contracting state agency prior to contract award and to complete another form within 30 days of contract completion or termination.

*This form was created by the State of West Virginia Ethics Commission, 210 Brooks Street, Suite 300, Charleston, WV 25301-1804. Telephone: (304)558-0664; fax: (304)558-2169; e-mail: [ethics@wv.gov](mailto:ethics@wv.gov); website: [www.ethics.wv.gov](http://www.ethics.wv.gov).*

West Virginia Ethics Commission  
**Disclosure of Interested Parties to Contracts**

(Required by W. Va. Code § 6D-1-2)

Contracting Business Entity: \_\_\_\_\_ Address: \_\_\_\_\_

Authorized Agent: \_\_\_\_\_ Address: \_\_\_\_\_

Contract Number: CRFG 0903 DOT 18 00000085 Contract Description: Flat Sheet aluminum

Governmental agency awarding contract: \_\_\_\_\_

Check here if this is a Supplemental Disclosure

List the Names of Interested Parties to the contract which are known or reasonably anticipated by the contracting business entity for each category below (attach additional pages if necessary):

**1. Subcontractors or other entities performing work or service under the Contract**

Check here if none, otherwise list entity/individual names below.

**2. Any person or entity who owns 25% or more of contracting entity (not applicable to publicly traded entities)**

Check here if none, otherwise list entity/individual names below.

**3. Any person or entity that facilitated, or negotiated the terms of, the applicable contract (excluding legal services related to the negotiation or drafting of the applicable contract)**

Check here if none, otherwise list entity/individual names below.

Signature: Melinda Thompson Date Signed: 4-23-18

**Notary Verification**

State of Ohio, County of Hocking:

I, Melinda Thompson, the authorized agent of the contracting business entity listed above, being duly sworn, acknowledge that the Disclosure herein is being made under oath and under the penalty of perjury.

Taken, sworn to and subscribed before me this 23rd day of April, 2018.

Michael E Grove  
Notary Public's Signature

**To be completed by State Agency:**

Date Received by State Agency: \_\_\_\_\_  
Date submitted to Ethics Commission: \_\_\_\_\_  
Governmental agency submitting Disclosure: \_\_\_\_\_



MICHAEL E GROVE  
Notary Public, State of Ohio  
My Commission Expires  
February 12, 2023

Revised October 7, 2017



JOHN A. MYERS  
CABINET SECRETARY

STATE OF WEST VIRGINIA  
DEPARTMENT OF ADMINISTRATION  
PURCHASING DIVISION  
2019 WASHINGTON STREET, EAST  
CHARLESTON, WEST VIRGINIA 25305-0130

W. MICHAEL SHEETS  
DIRECTOR

## State of West Virginia Bid Opportunity

<b>Solicitation Type</b>	CRFQ
<b>Solicitation No.</b>	DOT1800000085
<b>Description:</b>	FLAT SHEET AND PRE-CUT ALUMINUM
<b>Deadline for Q&amp;A:</b>	04/16/18
<b>Mandatory Bid Conference:</b>	N/A
<b>Bid Closing Date and Time:</b>	04/26/18 1:30 PM EST

APR 09 2018

Dear Potential Bidder:

Your business has been identified as a potential vendor by the requesting agency for the solicitation noted above.

Should your business be interested in this bid opportunity, please visit [www.wvOASIS.gov](http://www.wvOASIS.gov), and click on the Vendor Self Service (VSS) Portal. At the welcome screen, please review any announcements and log into your account or click on the "Public Access" button in the bottom left of the page in order to view the *West Virginia Purchasing Bulletin*. At the *West Virginia Purchasing Bulletin* page, you may view all bid opportunities or you may search for the solicitation noted above by typing the solicitation number in the "keyword search" box. All modifications to solicitations prior to award will be noted as an "addendum" and also available at this same location.

The *West Virginia Purchasing Bulletin* lists all bid opportunities more than \$5,000 for the state of West Virginia. Solicitations prefaced with an "A" are agency-delegated bid opportunities expected to be \$25,000 or less; those prefaced with an "C" are central Purchasing Division solicitations expected to exceed \$25,000.

Additional information may be accessed by clicking on the summary or details of the solicitation.

Should you decide to bid on this opportunity, you may submit a bid through the acceptable delivery methods including electronic submission via wvOASIS system, hand delivery, delivery by courier, or by facsimile; however, the Purchasing Division cannot accept bids via electronic mail.

Thank you for your interest in doing business with the State of West Virginia. Should you have any questions regarding becoming a registered vendor with the Purchasing Division, please visit our vendor registration webpage at <http://www.state.wv.us/admin/purchase/VendorReg.html>.

West Virginia Purchasing Division  
[WVPurchasing.gov](http://WVPurchasing.gov)