



Purchasing Division  
 2019 Washington Street East  
 Post Office Box 50130  
 Charleston, WV 25305-0130

State of West Virginia  
 Request for Quotation  
 36 - Vehicles

Proc Folder: 413604

Doc Description: Class 371 41,000 GVWR Single Axle Dump Truck w/ Accessories

Proc Type: Central Master Agreement

Date Issued	Solicitation Closes	Solicitation No	Version
2018-01-30	2018-03-01 13:30:00	CRFQ 0803 DOT1800000052	1

**BID RECEIVING LOCATION**

BID CLERK  
 DEPARTMENT OF ADMINISTRATION  
 PURCHASING DIVISION  
 2019 WASHINGTON ST E  
 CHARLESTON WV 25305  
 US

**VENDOR**

Vendor Name, Address and Telephone Number:

Heritage Equipment Inc.  
 322 Dry Hill Road  
 Beckley, WV 25801  
 304-887-1044

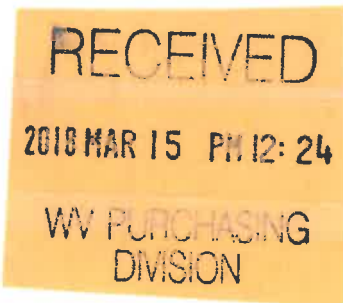

**FOR INFORMATION CONTACT THE BUYER**

Mark A Atkins  
 (304) 558-2307  
 mark.a.atkins@wv.gov

Signature X

FEIN #

550759079

DATE

3-15-2018

All offers subject to all terms and conditions contained in this solicitation



Purchasing Division  
 2019 Washington Street East  
 Post Office Box 50130  
 Charleston, WV 25305-0130

State of West Virginia  
 Request for Quotation  
 36 – Vehicles

Proc Folder: 413604

Doc Description: ADDENDUM\_1: Class 371 41,000 GVWR Single Axle Dump Truck

Proc Type: Central Master Agreement

Date Issued	Solicitation Closes	Solicitation No	Version
2018-02-05	2018-03-08 13:30:00	CRFQ 0803 DOT1800000052	2

**BID RECEIVING LOCATION**

BID CLERK  
 DEPARTMENT OF ADMINISTRATION  
 PURCHASING DIVISION  
 2019 WASHINGTON ST E  
 CHARLESTON WV 25305  
 US

**VENDOR**

Vendor Name, Address and Telephone Number:  
 Heritage Equipment Inc.  
 322 Dry Hill Road  
 Beckley, WV 25801  
 304-887-1044

**FOR INFORMATION CONTACT THE BUYER**

Mark A Atkins  
 (304) 558-2307  
 mark.a.atkins@wv.gov

Signature X *Mark Atkins*

FEIN # 550759079

DATE 3/15/18

All offers subject to all terms and conditions contained in this solicitation



Purchasing Division  
 2019 Washington Street East  
 Post Office Box 50130  
 Charleston, WV 25305-0130

State of West Virginia  
 Request for Quotation  
 36 – Vehicles

Proc Folder: 413604

Doc Description: ADDENDUM\_2: Class 371 41,000 GVWR Single Axle Dump Truck

Proc Type: Central Master Agreement

Date Issued	Solicitation Closes	Solicitation No	Version
2018-03-06	2018-03-15 13:30:00	CRFQ 0803 DOT1800000052	3

**BID RECEIVING LOCATION**

BID CLERK  
 DEPARTMENT OF ADMINISTRATION  
 PURCHASING DIVISION  
 2019 WASHINGTON ST E  
 CHARLESTON WV 25305  
 US

**VENDOR**

Vendor Name, Address and Telephone Number:

Heritage Equipment Inc.  
 322 Dry Hill Road  
 Beckley, WV 25801  
 304-887-1044

**FOR INFORMATION CONTACT THE BUYER**

Mark A Atkins  
 (304) 558-2307  
 mark.a.atkins@wv.gov

Signature X

FEIN #

550759079

DATE

3-15-2018

All offers subject to all terms and conditions contained in this solicitation

**DESIGNATED CONTACT:** Vendor appoints the individual identified in this Section as the Contract Administrator and the initial point of contact for matters relating to this Contract.

Mike Coburn Fleet Sales Manager  
(Name, Title)  
Mike Coburn  
(Printed Name and Title)  
322 Dry Hill Road Beckley, WV 25801  
(Address)  
304-887-1044 304-254-9007  
(Phone Number) / (Fax Number)  
mikecoburntrucks@gmail.com  
(email address)

**CERTIFICATION AND SIGNATURE:** By signing below, or submitting documentation through wvOASIS, I certify that I have reviewed this Solicitation in its entirety; that I understand the requirements, terms and conditions, and other information contained herein; that this bid, offer or proposal constitutes an offer to the State that cannot be unilaterally withdrawn; that the product or service proposed meets the mandatory requirements contained in the Solicitation for that product or service, unless otherwise stated herein; that the Vendor accepts the terms and conditions contained in the Solicitation, unless otherwise stated herein; that I am submitting this bid, offer or proposal for review and consideration; that I am authorized by the vendor to execute and submit this bid, offer, or proposal, or any documents related thereto on vendor's behalf; that I am authorized to bind the vendor in a contractual relationship; and that to the best of my knowledge, the vendor has properly registered with any State agency that may require registration.

Heritage Equipment Inc.  
(Company)  
Mike Coburn  
(Authorized Signature) (Representative Name, Title)  
Mike Coburn Fleet Sales Manager  
(Printed Name and Title of Authorized Representative)  
March 15, 2018  
(Date)  
304-887-1044 304-254-9007  
(Phone Number) (Fax Number)

# SOLICITATION NUMBER: CRFQ 0803 DOT1800000052

## Addendum Number: 1

---

The purpose of this addendum is to modify the solicitation identified as CRFQ 0803 DOT1800000052 ("Solicitation") to reflect the change(s) identified and described below.

### Applicable Addendum Category:

- Modify bid opening date and time
- Modify Technical Question due date and time
- Attachment of vendor questions and responses
- Attachment of pre-bid sign-in sheet
- Correction of error
- Other

### Description of Modification to Solicitation:

1. To move the bid opening date from 03/01/2018 to 03/08/2018 at 1:30pm EST.
2. To move the Technical Questioning deadline period from 02/21/2018 to 02//2018 due by 2:00pm EST.

No other changes made.

**Additional Documentation:** Documentation related to this Addendum (if any) has been included herewith as Attachment A and is specifically incorporated herein by reference.

### Terms and Conditions:

1. All provisions of the Solicitation and other addenda not modified herein shall remain in full force and effect.
2. Vendor should acknowledge receipt of all addenda issued for this Solicitation by completing an Addendum Acknowledgment, a copy of which is included herewith. Failure to acknowledge addenda may result in bid disqualification. The addendum acknowledgement should be submitted with the bid to expedite document processing.

**ADDENDUM ACKNOWLEDGEMENT FORM**  
**SOLICITATION NO.: CRFO 0803 DOT180000052**

**Instructions:** Please acknowledge receipt of all addenda issued with this solicitation by completing this addendum acknowledgment form. Check the box next to each addendum received and sign below. Failure to acknowledge addenda may result in bid disqualification.

**Acknowledgment:** I hereby acknowledge receipt of the following addenda and have made the necessary revisions to my proposal, plans and/or specification, etc.

**Addendum Numbers Received:**  
(Check the box next to each addendum received)

- |  |  |
|--|--|
| <input checked="" type="checkbox"/> Addendum No. 1 | <input type="checkbox"/> Addendum No. 6  |
| <input checked="" type="checkbox"/> Addendum No. 2 | <input type="checkbox"/> Addendum No. 7  |
| <input type="checkbox"/> Addendum No. 3            | <input type="checkbox"/> Addendum No. 8  |
| <input type="checkbox"/> Addendum No. 4            | <input type="checkbox"/> Addendum No. 9  |
| <input type="checkbox"/> Addendum No. 5            | <input type="checkbox"/> Addendum No. 10 |

I understand that failure to confirm the receipt of addenda may be cause for rejection of this bid. I further understand that that any verbal representation made or assumed to be made during any oral discussion held between Vendor's representatives and any state personnel is not binding. Only the information issued in writing and added to the specifications by an official addendum is binding.

Heritage Equipment, Inc.  
Company

Mike Johnson  
Authorized Signature

3-15-2018  
Date

**NOTE:** This addendum acknowledgement should be submitted with the bid to expedite document processing.

West Virginia Ethics Commission  
**Disclosure of Interested Parties to Contracts**

(Required by W. Va. Code § 6D-1-2)

Contracting Business Entity: Heritage Equipment Inc Address: 322 Dry Hill Rd Beckley, WV  
25801

Authorized Agent: Mike Coburn Address: 322 Dry Hill Rd Beckley, WV  
25801

Contract Number: CRFQ 0803 DOT1800000052 Contract Description: Class 371 41,000 GVWR  
Single Axle Dump Truck w/Accessories

Governmental agency awarding contract: \_\_\_\_\_

Check here if this is a Supplemental Disclosure

List the Names of Interested Parties to the contract which are known or reasonably anticipated by the contracting business entity for each category below (attach additional pages if necessary):

**1. Subcontractors or other entities performing work or service under the Contract**

Check here if none, otherwise list entity/individual names below.

**2. Any person or entity who owns 25% or more of contracting entity (not applicable to publicly traded entities)**

Check here if none, otherwise list entity/individual names below.

**3. Any person or entity that facilitated, or negotiated the terms of, the applicable contract (excluding legal services related to the negotiation or drafting of the applicable contract)**

Check here if none, otherwise list entity/individual names below.

Signature: Mike Coburn

Date Signed: 3-15-2018

**Notary Verification**

State of WV, County of Raleigh:

I, Mike Coburn, the authorized agent of the contracting business entity listed above, being duly sworn, acknowledge that the Disclosure herein is being made under oath and under the penalty of perjury.

Taken, sworn to and subscribed before me this 15<sup>th</sup> day of March 2018.

Donna S Johnson  
Notary Public's Signature

**To be completed by State Agency:**

Date Received by State Agency: \_\_\_\_\_

Date submitted to Ethics Commission: \_\_\_\_\_

Governmental agency submitting Disclosure: \_\_\_\_\_

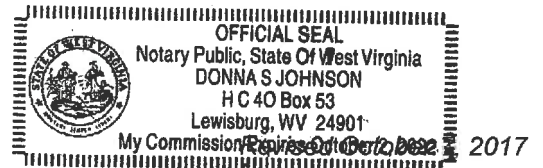

STATE OF WEST VIRGINIA  
Purchasing Division

# PURCHASING AFFIDAVIT

**CONSTRUCTION CONTRACTS:** Under W. Va. Code § 5-22-1(i), the contracting public entity shall not award a construction contract to any bidder that is known to be in default on any monetary obligation owed to the state or a political subdivision of the state, including, but not limited to, obligations related to payroll taxes, property taxes, sales and use taxes, fire service fees, or other fines or fees.

**ALL CONTRACTS:** Under W. Va. Code §5A-3-10a, no contract or renewal of any contract may be awarded by the state or any of its political subdivisions to any vendor or prospective vendor when the vendor or prospective vendor or a related party to the vendor or prospective vendor is a debtor and: (1) the debt owed is an amount greater than one thousand dollars in the aggregate; or (2) the debtor is in employer default.

**EXCEPTION:** The prohibition listed above does not apply where a vendor has contested any tax administered pursuant to chapter eleven of the W. Va. Code, workers' compensation premium, permit fee or environmental fee or assessment and the matter has not become final or where the vendor has entered into a payment plan or agreement and the vendor is not in default of any of the provisions of such plan or agreement.

**DEFINITIONS:**

**"Debt"** means any assessment, premium, penalty, fine, tax or other amount of money owed to the state or any of its political subdivisions because of a judgment, fine, permit violation, license assessment, defaulted workers' compensation premium, penalty or other assessment presently delinquent or due and required to be paid to the state or any of its political subdivisions, including any interest or additional penalties accrued thereon.

**"Employer default"** means having an outstanding balance or liability to the old fund or to the uninsured employers' fund or being in policy default, as defined in W. Va. Code § 23-2c-2, failure to maintain mandatory workers' compensation coverage, or failure to fully meet its obligations as a workers' compensation self-insured employer. An employer is not in employer default if it has entered into a repayment agreement with the Insurance Commissioner and remains in compliance with the obligations under the repayment agreement.

**"Related party"** means a party, whether an individual, corporation, partnership, association, limited liability company or any other form or business association or other entity whatsoever, related to any vendor by blood, marriage, ownership or contract through which the party has a relationship of ownership or other interest with the vendor so that the party will actually or by effect receive or control a portion of the benefit, profit or other consideration from performance of a vendor contract with the party receiving an amount that meets or exceeds five percent of the total contract amount.

**AFFIRMATION:** By signing this form, the vendor's authorized signer affirms and acknowledges under penalty of law for false swearing (W. Va. Code §61-5-3) that: (1) for construction contracts, the vendor is not in default on any monetary obligation owed to the state or a political subdivision of the state, and (2) for all other contracts, that neither vendor nor any related party owe a debt as defined above and that neither vendor nor any related party are in employer default as defined above, unless the debt or employer default is permitted under the exception above.

**WITNESS THE FOLLOWING SIGNATURE:**

Vendor's Name: Heritage Equipment Inc.

Authorized Signature: *Mike Quinn* Date: 3/15/18

State of WV

County of Raleigh, to-wit:

Taken, subscribed, and sworn to before me this 15<sup>th</sup> day of March, 2018.

My Commission expires October 2, 2022.

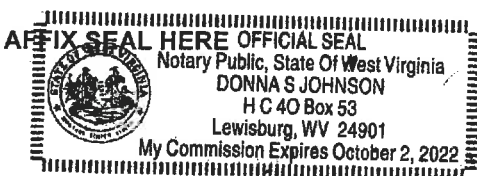

NOTARY PUBLIC *Donna S. Johnson*



# State of West Virginia

## VENDOR PREFERENCE CERTIFICATE

Certification and application is hereby made for Preference in accordance with *West Virginia Code*, §5A-3-37. (Does not apply to construction contracts). *West Virginia Code*, §5A-3-37, provides an opportunity for qualifying vendors to request (at the time of bid) preference for their residency status. Such preference is an evaluation method only and will be applied only to the cost bid in accordance with the *West Virginia Code*. This certificate for application is to be used to request such preference. The Purchasing Division will make the determination of the Vendor Preference, if applicable.

1.  **Application is made for 2.5% vendor preference for the reason checked:**  
Bidder is an individual resident vendor and has resided continuously in West Virginia, or bidder is a partnership, association or corporation resident vendor and has maintained its headquarters or principal place of business continuously in West Virginia, for four (4) years immediately preceding the date of this certification; or,  
 Bidder is a resident vendor partnership, association, or corporation with at least eighty percent of ownership interest of bidder held by another entity that meets the applicable four year residency requirement; or,  
 Bidder is a nonresident vendor which has an affiliate or subsidiary which employs a minimum of one hundred state residents and which has maintained its headquarters or principal place of business within West Virginia continuously for the four (4) years immediately preceding the date of this certification; or,
2.  **Application is made for 2.5% vendor preference for the reason checked:**  
Bidder is a resident vendor who certifies that, during the life of the contract, on average at least 75% of the employees working on the project being bid are residents of West Virginia who have resided in the state continuously for the two years immediately preceding submission of this bid; or,
3.  **Application is made for 2.5% vendor preference for the reason checked:**  
Bidder is a nonresident vendor that employs a minimum of one hundred state residents, or a nonresident vendor which has an affiliate or subsidiary which maintains its headquarters or principal place of business within West Virginia and employs a minimum of one hundred state residents, and for purposes of producing or distributing the commodities or completing the project which is the subject of the bidder's bid and continuously over the entire term of the project, on average at least seventy-five percent of the bidder's employees or the bidder's affiliate's or subsidiary's employees are residents of West Virginia who have resided in the state continuously for the two immediately preceding years and the vendor's bid; or,
4.  **Application is made for 5% vendor preference for the reason checked:**  
Bidder meets either the requirement of both subdivisions (1) and (2) or subdivision (1) and (3) as stated above; or,
5.  **Application is made for 3.5% vendor preference who is a veteran for the reason checked:**  
Bidder is an individual resident vendor who is a veteran of the United States armed forces, the reserves or the National Guard and has resided in West Virginia continuously for the four years immediately preceding the date on which the bid is submitted; or,
6.  **Application is made for 3.5% vendor preference who is a veteran for the reason checked:**  
Bidder is a resident vendor who is a veteran of the United States armed forces, the reserves or the National Guard, if, for purposes of producing or distributing the commodities or completing the project which is the subject of the vendor's bid and continuously over the entire term of the project, on average at least seventy-five percent of the vendor's employees are residents of West Virginia who have resided in the state continuously for the two immediately preceding years.
7.  **Application is made for preference as a non-resident small, women- and minority-owned business, in accordance with *West Virginia Code* §5A-3-59 and *West Virginia Code of State Rules*.**  
Bidder has been or expects to be approved prior to contract award by the Purchasing Division as a certified small, women- and minority-owned business.

Bidder understands if the Secretary of Revenue determines that a Bidder receiving preference has failed to continue to meet the requirements for such preference, the Secretary may order the Director of Purchasing to: (a) rescind the contract or purchase order; or (b) assess a penalty against such Bidder in an amount not to exceed 5% of the bid amount and that such penalty will be paid to the contracting agency or deducted from any unpaid balance on the contract or purchase order.

By submission of this certificate, Bidder agrees to disclose any reasonably requested information to the Purchasing Division and authorizes the Department of Revenue to disclose to the Director of Purchasing appropriate information verifying that Bidder has paid the required business taxes, provided that such information does not contain the amounts of taxes paid nor any other information deemed by the Tax Commissioner to be confidential.

**Bidder hereby certifies that this certificate is true and accurate in all respects; and that if a contract is issued to Bidder and if anything contained within this certificate changes during the term of the contract, Bidder will notify the Purchasing Division in writing immediately.**

Bidder: Heritage Equipment Inc.

Signed: 

Date: March 15, 2018

Title: Fleet Sales Manager

CRFQ 0803 DOT1800000052  
REQUEST FOR QUOTATION  
(Class 371) 41,000 GVWR Single Axle Dump Truck  
w/ Hydraulic System, Snow Plow, and V-Box Spreader

---

7.1.3 Failure to comply with any laws, rules, and ordinances applicable to the Contract Services provided under this Contract.

7.1.4 Failure to remedy deficient performance upon request.

7.2 The following remedies shall be available to Agency upon default.

7.2.1 Immediate cancellation of the Contract.

7.2.2 Immediate cancellation of one or more release orders issued under this Contract.

7.2.3 Any other remedies available in law or equity.

**8. MISCELLANEOUS:**

**8.1 No Substitutions:** Vendor shall supply only Contract Items submitted in response to RFQ unless a contract modification is approved in accordance with the provisions contained in this contract.

**8.2 Reports:** Vendor shall provide quarterly reports and annual summaries to the Agency showing the Agency's items purchased, quantities of items purchased, and total dollar value of the items purchased. Vendor shall also provide reports, upon request, showing the items purchased during the term of this Contract, the quantity purchased for each of those items, and the total value of purchases for each of those items. Failure to supply such reports may be grounds for cancellation of this Contract.

**8.3 Contract Manager:** During its performance of this Contract, Vendor must designate and maintain a primary contract manager responsible for overseeing Vendor's responsibilities under this Contract. The Contract manager must be available during normal business hours to address any customer service or other issues related to this Contract. Vendor should list its Contract manager and his or her contact information below.

Contract Manager: Mike Coburn  
Telephone Number: 304-887-1044  
Fax Number: 304-254-9007  
Email Address: mikecoburntrucks@gmail.com

EXHIBIT\_A PRICING PAGE

CRFQ 0803 DOT1800000052

**Class 371 41,000 GVWR Single Axle Dump Truck**

Item No.	Description:	Make/Model & Year	Estimated Unit Quantity	Unit Price	Item Total Cost
1	<b>Complete Unit: Cab Chassis/Dump Body w/Hyd. System w/Front 10' snow plow &amp; V-box spreader</b>	MAKE: Western Star MODEL: 4700 YEAR: 2019	60	\$ 182,750.00	\$ 10,965,000.00
2	<b>Complete Unit: Cab Chassis/Dump Body w/Hyd. System, w/Front 11' snow plow &amp; V-box spreader</b>	MAKE: Western Star MODEL: 4700 YEAR: 2019	60	\$ 183,150.00	\$ 10,989,000.00
<b>Total Bid Cost</b>					<b>\$ 21,954,000.00</b>

VENDOR: HERITAGE EQUIPMENT INC.  
 CONTACT NAME: MIKE COBURN  
 CONTACT PHONE: 304-887-1044  
 CONTACT EMAIL: mikecoburntrucks@gmail.com

**Bid will be awarded to the lowest overall bid total for all items**



**WESTERN STAR**

**4700** SF SB

Dump | Mixer | Crane  
Snowplow | Roll-off | Sewer Vac



**Serious trucks.®**

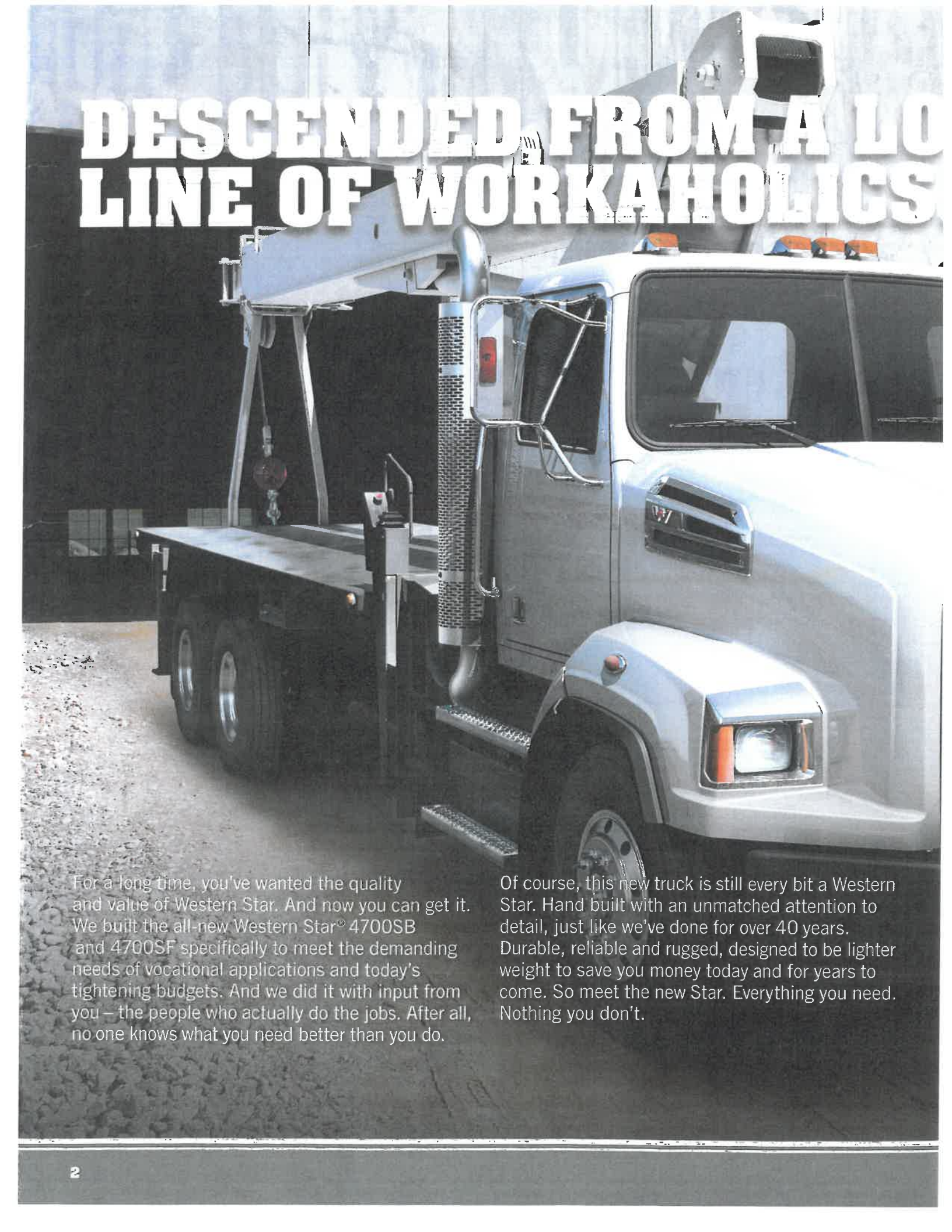

# DESCENDED FROM A LO LINE OF WORKAHOLICS

For a long time, you've wanted the quality and value of Western Star. And now you can get it. We built the all-new Western Star® 4700SB and 4700SF specifically to meet the demanding needs of vocational applications and today's tightening budgets. And we did it with input from you – the people who actually do the jobs. After all, no one knows what you need better than you do.

Of course, this new truck is still every bit a Western Star. Hand built with an unmatched attention to detail, just like we've done for over 40 years. Durable, reliable and rugged, designed to be lighter weight to save you money today and for years to come. So meet the new Star. Everything you need. Nothing you don't.

NG



## The all-steel, corrosion-resistant office.

No aluminum or rivets here. That just wouldn't be strong enough. Our galvanized steel cabs are built to keep you safe. Extra gussets and reinforcements, bonded instead of riveted, precision welded for strength, then dipped and protected with a 17-stage e-coat process for long-lasting corrosion resistance and a superior paint finish. Strength and longevity are the goals. We'd say they've been exceeded.

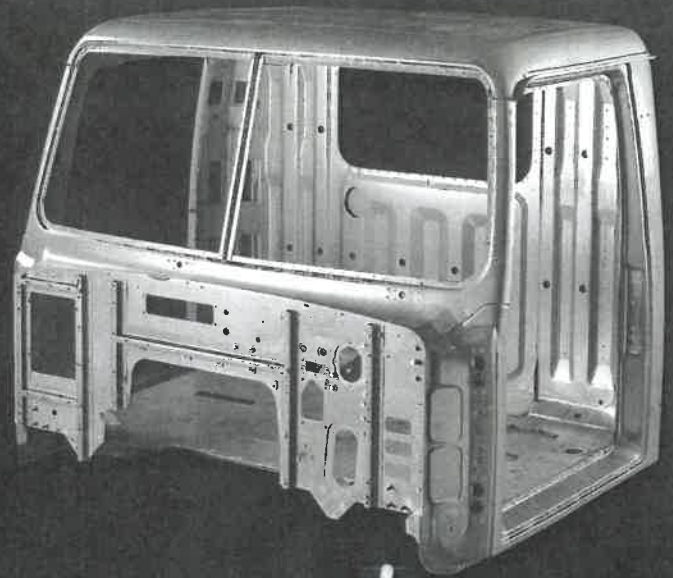

### A NEW INTERIOR DESIGNED TO FIT THE WAY YOU WORK.

The interior of the Western Star 4700 isn't built just to look pretty. It's built to make the job easier. A 72-inch-wide cab that's simple to get in and out of. Greater visibility. And a selection of new colors and finishes for a workplace that's brighter and easier to clean. One with loads of storage in the doors and between the seats, as well as features like customizable marine-grade switches and a hinged dash with exposed fasteners for improved serviceability. Yes, form does meet function.

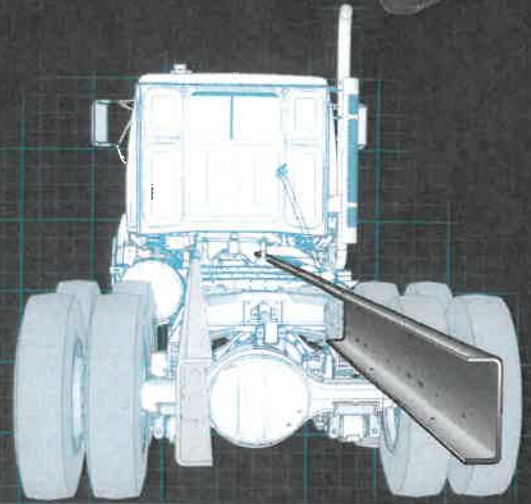

### HEAVYWEIGHT PERFORMANCE. WITHOUT THE HEAVY.

Yes, you can get strong and light. The half-inch-thick, single-channel frame rails available on the 4700 give you both. Rated at 3.2M RBM, they also come custom drilled for your application, for added strength. And since they aren't stacked, it's harder for corrosion to start. Good idea.

### THE RIGHT SIZE TO DO JUST ABOUT ANYTHING.

With a newly designed sloped hood and a 110-inch BBC, the 4700 offers unobstructed sight lines with incredible visibility. Plus, its shorter overall length, when combined with a 55-degree wheel cut, gives you the maneuverability to get into – and out of – some pretty tight spots.

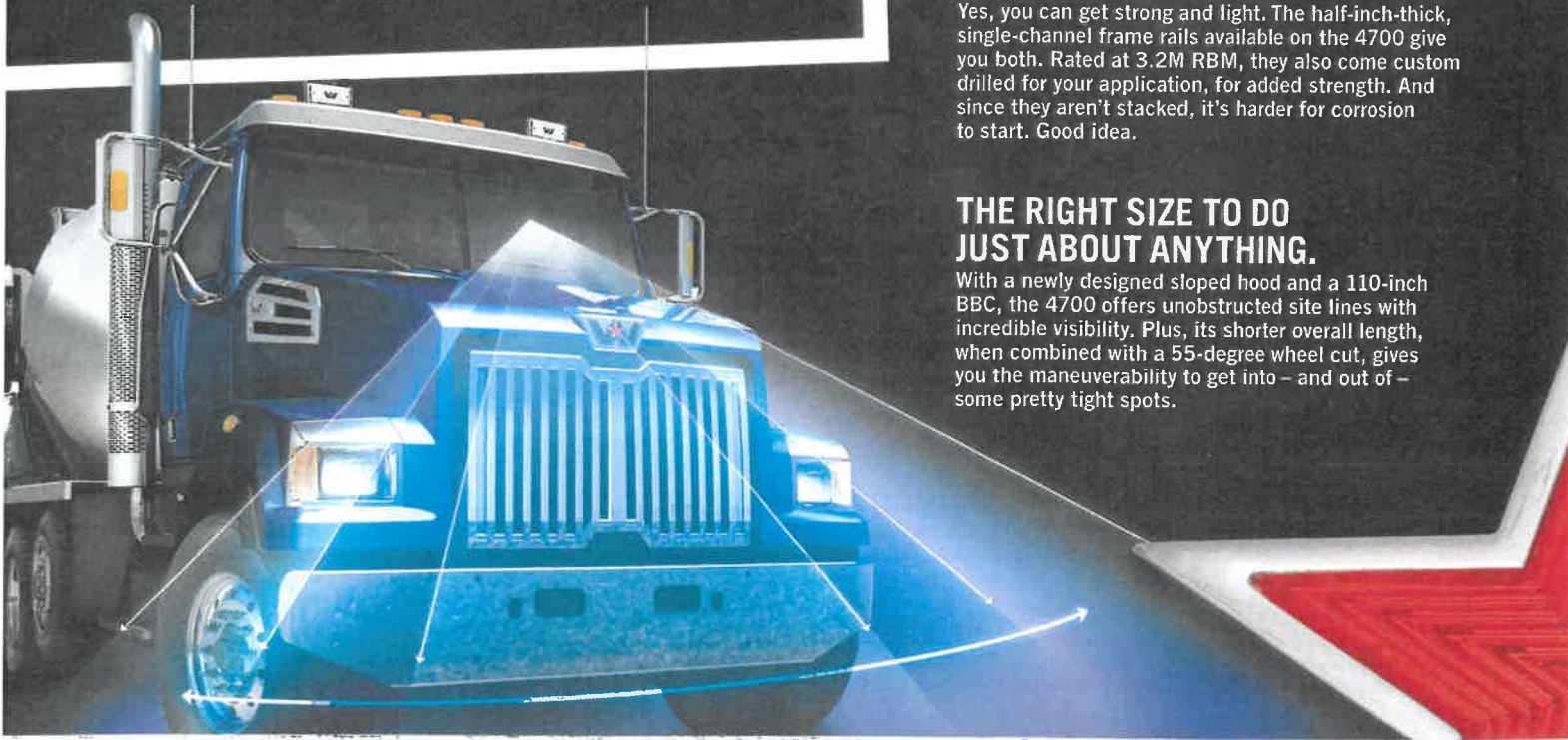



## Wiring made easy.

Few things can speed up an installation like smart wiring. So we put our body builder interface connector and transmission control unit in the cab and out of the elements. You'll also find a bolt-in pass-through plate in the cab floor to eliminate unnecessary drilling, and a dedicated floor channel with an easy-to-remove top that provides plenty of room for you to run your own wiring. Anything to make it easy.

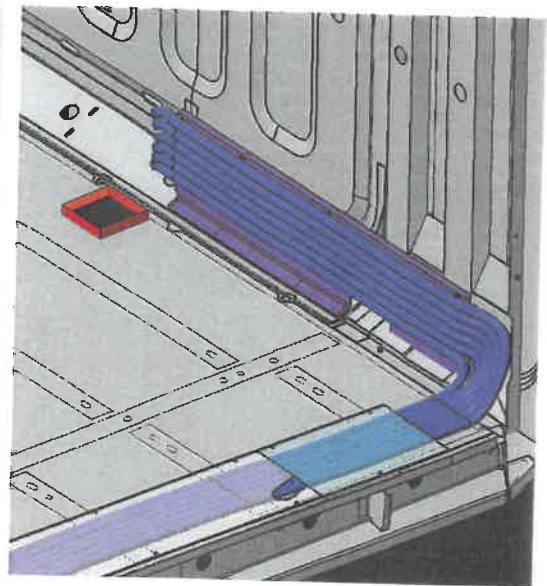



# JUST WHAT THE BODY BUILDERS ASKED FOR.

We didn't only talk to owners. We talked to body builders, too. Which is why we built the all-new Western Star® 4700SB and 4700SF with the features and body builder-specific options that reduce their installation time and save you money. Clean back of cab, in-cab batteries for clear frame rails, front frame extensions, ample room between the seats to install auxiliary equipment, and the list goes on. Just ask your dealer for more details.

## **There's more than one way to run an exhaust.**

Whether you need a clean back of cab or are looking for options to maximize fuel capacity, you'll find the exhaust options to make your truck a reality.

## **Pumps. Outriggers. And PTOs.**

The 4700 comes standard with a stationary grille to make installing the equipment you need a little more convenient.

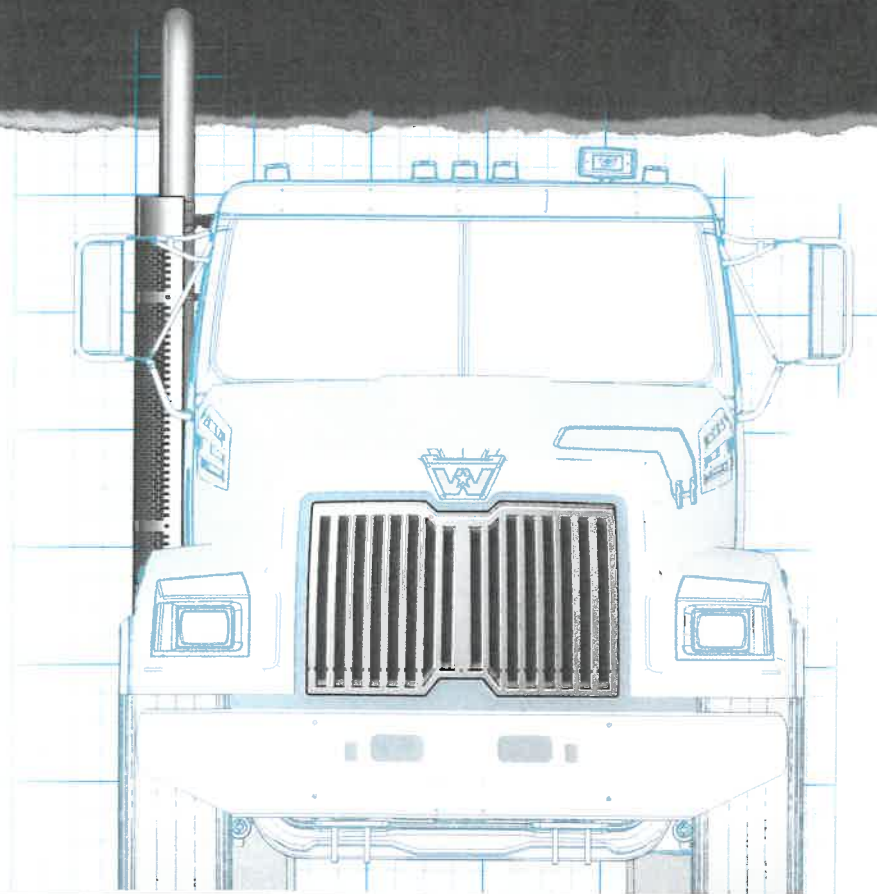

# To us, close enough just isn't good enough.

When it comes to choosing an engine, close enough should never enter the conversation. That's why we offer a variety of Detroit™ and Cummins engine choices to give you the widest range of horsepower ratings for your application.

**CUMMINS ISC**  
260-350, 1000lb-ft.

**CUMMINS ISL**  
345-380HP, 1150-1300lb-ft.

**DETROIT™ DD13®**  
350-470HP, 1250-1650lb-ft.

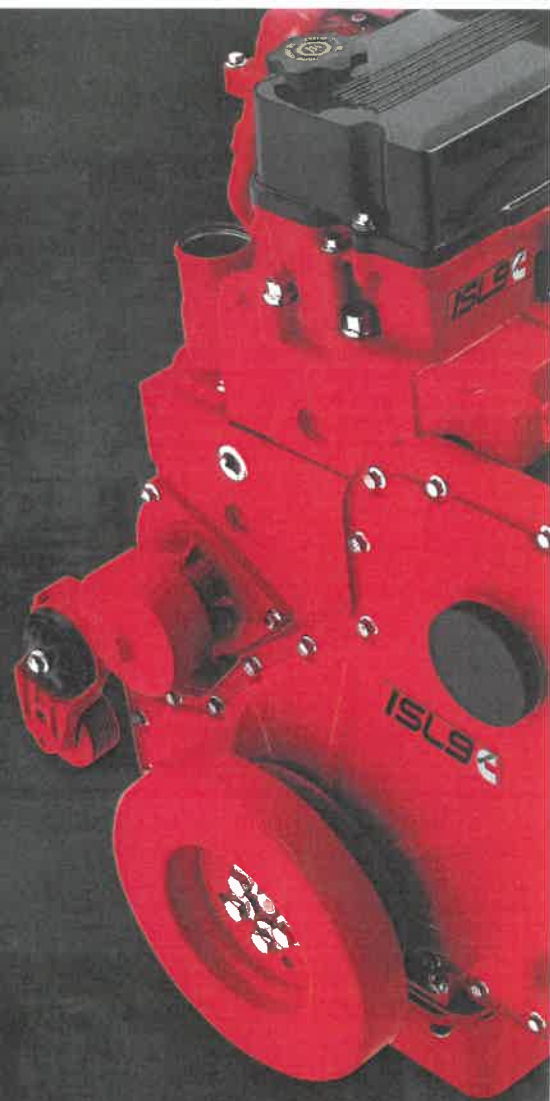

**DETROIT™**

**BLUETEC™**

## SCR. JUST ANOTHER WAY TO MAKE YOU MONEY.

SCR (Selective Catalytic Reduction) is a simple yet cost-effective solution to meeting today's challenging emission requirements while improving engine power and efficiency. With reduced maintenance, better fuel economy and less regenerations, SCR helps increase engine performance and reliability for greater uptime. Whether you're driving to the job site or running the PTO when you're hard at work, SCR is the proven emissions system that provides a substantial return on your investment.

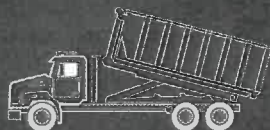
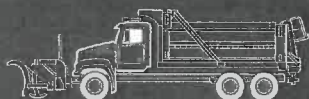
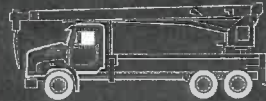
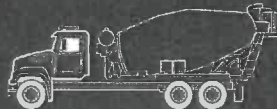
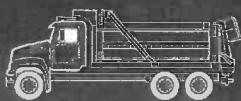

## THE RIGHT TRUCK FOR THE JOB. ANY JOB.

The 4700 was engineered to be versatile. Easy to body up and built to last. The only question left to answer is how many you should order.



# 4700

## SF SET FORWARD AXLE

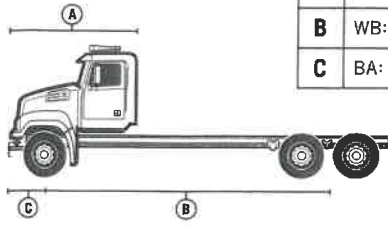

<b>A</b>	BBC: 110"
<b>B</b>	WB: Up to 300"
<b>C</b>	BA: 29"

## SB SET BACK AXLE

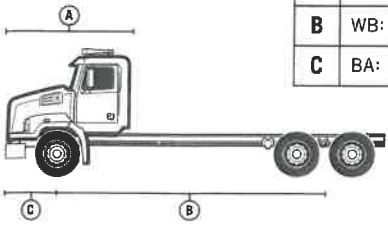

<b>A</b>	BBC: 110"
<b>B</b>	WB: Up to 300"
<b>C</b>	BA: 47"

### PARTS AND SERVICE, WHEN YOU NEED THEM.

Our goal is to keep you working. That's why your dealer has an experienced service center team and carries a wide selection of parts, with access to an even greater variety through our expanding global network of parts distribution centers. You get the support you need to grow – no matter where you do business.

### YOUR KIND OF FINANCING PROGRAMS.

Being part of the Daimler Truck Financial family means we can get you into the right truck at the right price with rates that are competitive with anyone, including banks. Plus, because we know the transportation and vocational business, it's simple to get the financing you need – and into the Western Star you want.

Daimler Truck Financial

Financing that works for you.



For the Western Star® dealer nearest you, call 1-866-850-STAR | [WESTERNSTAR.COM](http://WESTERNSTAR.COM)

WS/MC-B-340. Specifications subject to change without notice. Western Star Truck Sales, Inc. is registered to ISO 9001:2000 and ISO 14001:2004. Copyright © 2012 Daimler Trucks North America LLC. All rights reserved. Western Star Truck Sales, Inc. is a subsidiary of Daimler Trucks North America LLC, a Daimler Company.