

Exhibit A

**Pricing Sheet**

**CRFQ 0803 DOT1700000086**

<b>Item Number</b>	<b>Estimated Quantity</b>	<b>Unit of Measure</b>	<b>Description</b>	<b>Unit Price Each</b>	<b>Total</b>
1	20	Each	One complete unit: Hydraulic Compact Excavator	\$ 53,539.00	\$ 1,070,780.00
				<b>Grand Total</b>	<b>\$ 1,070,780.00</b>

Vendor shall list the year, make, and model of the unit being bid:

Year: \_\_\_\_\_ 2017

Make: \_\_\_\_\_ Bobcat

Model: E50



08/16/17 11:58:34  
Purchasing Division

Exhibit A

Pricing Sheet

CRFQ 0803 DOT1700000086

Item Number	Estimated Quantity	Unit of Measure	Description	Unit Price Each	Total
1	20	Each	One complete unit: Hydraulic Compact Excavator	\$ 53,539.00	\$ 1,070,780.00
				<b>Grand Total</b>	<b>\$ 1,070,780.00</b>

Vendor shall list the year, make, and model of the unit being bid:

Year: \_\_\_\_\_ 2017

Make: \_\_\_\_\_ Bobcat

Model: E50

**Bobcat.**  
**Of Advantage Valley**  
A Division of Jefferds Corporation  
 614 New Goff Mountain Road  
 Cross Lanes WV 25313



614 New Goff Mt. Road • Cross Lanes, WV 25313  
 (304) 776-9100 • Fax (304) 776-0285  
 1 866-4BOBCAT • Cell (304) 561-8280  
 Email: [stevew@jefferds.com](mailto:stevew@jefferds.com)  
 Web: [www.BobcatWV.com](http://www.BobcatWV.com)

**Steve Lewis**  
 Bobcat Specialist

STATE OF WEST VIRGINIA  
Purchasing Division

**PURCHASING AFFIDAVIT**

**MANDATE:** Under W. Va. Code §5A-3-10a, no contract or renewal of any contract may be awarded by the state or any of its political subdivisions to any vendor or prospective vendor when the vendor or prospective vendor or a related party to the vendor or prospective vendor is a debtor and: (1) the debt owed is an amount greater than one thousand dollars in the aggregate; or (2) the debtor is in employer default.

**EXCEPTION:** The prohibition listed above does not apply where a vendor has contested any tax administered pursuant to chapter eleven of the W. Va. Code, workers' compensation premium, permit fee or environmental fee or assessment and the matter has not become final or where the vendor has entered into a payment plan or agreement and the vendor is not in default of any of the provisions of such plan or agreement.

**DEFINITIONS:**

**"Debt"** means any assessment, premium, penalty, fine, tax or other amount of money owed to the state or any of its political subdivisions because of a judgment, fine, permit violation, license assessment, defaulted workers' compensation premium, penalty or other assessment presently delinquent or due and required to be paid to the state or any of its political subdivisions, including any interest or additional penalties accrued thereon.

**"Employer default"** means having an outstanding balance or liability to the old fund or to the uninsured employers' fund or being in policy default, as defined in W. Va. Code § 23-2c-2, failure to maintain mandatory workers' compensation coverage, or failure to fully meet its obligations as a workers' compensation self-insured employer. An employer is not in employer default if it has entered into a repayment agreement with the Insurance Commissioner and remains in compliance with the obligations under the repayment agreement.

**"Related party"** means a party, whether an individual, corporation, partnership, association, limited liability company or any other form or business association or other entity whatsoever, related to any vendor by blood, marriage, ownership or contract through which the party has a relationship of ownership or other interest with the vendor so that the party will actually or by effect receive or control a portion of the benefit, profit or other consideration from performance of a vendor contract with the party receiving an amount that meets or exceeds five percent of the total contract amount.

**AFFIRMATION:** By signing this form, the vendor's authorized signer affirms and acknowledges under penalty of law for false swearing (W. Va. Code §61-5-3) that neither vendor nor any related party owe a debt as defined above and that neither vendor nor any related party are in employer default as defined above, unless the debt or employer default is permitted under the exception above.

**WITNESS THE FOLLOWING SIGNATURE:**

Vendor's Name: JEFFERDS CORPORATION DBA BOBCAT OF ADVANTAGE VALLEY

Authorized Signature: Rodney P. Zou Date: 8-15-17

State of West Virginia

County of Putnam, to-wit:

Taken, subscribed, and sworn to before me this 15<sup>th</sup> day of August, 2017.

My Commission expires 6-30, 2018.

AFFIX SEAL HERE

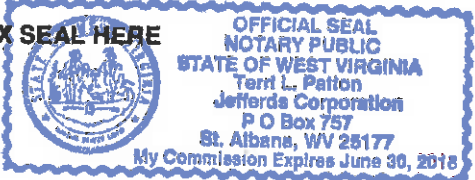

NOTARY PUBLIC Tert L. Patton

State of West Virginia  
**VENDOR PREFERENCE CERTIFICATE**

Certification and application is hereby made for Preference in accordance with **West Virginia Code**, §5A-3-37. (Does not apply to construction contracts). **West Virginia Code**, §5A-3-37, provides an opportunity for qualifying vendors to request (at the time of bid) preference for their residency status. Such preference is an evaluation method only and will be applied only to the cost bid in accordance with the **West Virginia Code**. This certificate for application is to be used to request such preference. The Purchasing Division will make the determination of the Vendor Preference, if applicable.

1.  **Application is made for 2.5% vendor preference for the reason checked:**  
 Bidder is an individual resident vendor and has resided continuously in West Virginia for four (4) years immediately preceding the date of this certification; **or**,  
 Bidder is a partnership, association or corporation resident vendor and has maintained its headquarters or principal place of business continuously in West Virginia for four (4) years immediately preceding the date of this certification;  
 Bidder is a resident vendor partnership, association, or corporation with at least eighty percent of ownership interest of bidder held by another entity that meets the applicable four year residency requirement; **or**,  
 Bidder is a nonresident vendor which has an affiliate or subsidiary which employs a minimum of one hundred state residents and which has maintained its headquarters or principal place of business within West Virginia continuously for the four (4) years immediately preceding the date of this certification; **or**,
2.  **Application is made for 2.5% vendor preference for the reason checked:**  
 Bidder is a resident vendor who certifies that, during the life of the contract, on average at least 75% of the employees working on the project being bid are residents of West Virginia who have resided in the state continuously for the two years immediately preceding submission of this bid; **or**,
3.  **Application is made for 2.5% vendor preference for the reason checked:**  
 Bidder is a nonresident vendor that employs a minimum of one hundred state residents, or a nonresident vendor which has an affiliate or subsidiary which maintains its headquarters or principal place of business within West Virginia and employs a minimum of one hundred state residents, and for purposes of producing or distributing the commodities or completing the project which is the subject of the bidder's bid and continuously over the entire term of the project, on average at least seventy-five percent of the bidder's employees or the bidder's affiliate's or subsidiary's employees are residents of West Virginia who have resided in the state continuously for the two immediately preceding years and the vendor's bid; **or**,
4.  **Application is made for 5% vendor preference for the reason checked:**  
 Bidder meets either the requirement of both subdivisions (1) and (2) or subdivision (1) and (3) as stated above; **or**,
5.  **Application is made for 3.5% vendor preference who is a veteran for the reason checked:**  
 Bidder is an individual resident vendor who is a veteran of the United States armed forces, the reserves or the National Guard and has resided in West Virginia continuously for the four years immediately preceding the date on which the bid is submitted; **or**,
6.  **Application is made for 3.5% vendor preference who is a veteran for the reason checked:**  
 Bidder is a resident vendor who is a veteran of the United States armed forces, the reserves or the National Guard, if, for purposes of producing or distributing the commodities or completing the project which is the subject of the vendor's bid and continuously over the entire term of the project, on average at least seventy-five percent of the vendor's employees are residents of West Virginia who have resided in the state continuously for the two immediately preceding years.
7.  **Application is made for preference as a non-resident small, women- and minority-owned business, in accordance with West Virginia Code §5A-3-59 and West Virginia Code of State Rules.**  
 Bidder has been or expects to be approved prior to contract award by the Purchasing Division as a certified small, women- and minority-owned business.

Bidder understands if the Secretary of Revenue determines that a Bidder receiving preference has failed to continue to meet the requirements for such preference, the Secretary may order the Director of Purchasing to: (a) rescind the contract or purchase order; or (b) assess a penalty against such Bidder in an amount not to exceed 5% of the bid amount and that such penalty will be paid to the contracting agency or deducted from any unpaid balance on the contract or purchase order.

By submission of this certificate, Bidder agrees to disclose any reasonably requested information to the Purchasing Division and authorizes the Department of Revenue to disclose to the Director of Purchasing appropriate information verifying that Bidder has paid the required business taxes, provided that such information does not contain the amounts of taxes paid nor any other information deemed by the Tax Commissioner to be confidential.

**Bidder hereby certifies that this certificate is true and accurate in all respects; and that if a contract is issued to Bidder and if anything contained within this certificate changes during the term of the contract, Bidder will notify the Purchasing Division in writing immediately.**

**Bidder:** Jeffers Corporation dba Bobcat of Advantage Valley

**Signed:** 

**Date:** 8-16-17

**Title:** Bobcat Specialist

\*Check any combination of preference consideration(s) indicated above, which you are entitled to receive.

## GENERAL TERMS AND CONDITIONS:

**1. CONTRACTUAL AGREEMENT:** Issuance of a Award Document signed by the Purchasing Division Director, or his designee, and approved as to form by the Attorney General's office constitutes acceptance of this Contract made by and between the State of West Virginia and the Vendor. Vendor's signature on its bid signifies Vendor's agreement to be bound by and accept the terms and conditions contained in this Contract.

**2. DEFINITIONS:** As used in this Solicitation/Contract, the following terms shall have the meanings attributed to them below. Additional definitions may be found in the specifications included with this Solicitation/Contract.

**2.1. "Agency" or "Agencies"** means the agency, board, commission, or other entity of the State of West Virginia that is identified on the first page of the Solicitation or any other public entity seeking to procure goods or services under this Contract.

**2.2. "Bid" or "Proposal"** means the vendors submitted response to this solicitation.

**2.3. "Contract"** means the binding agreement that is entered into between the State and the Vendor to provide the goods or services requested in the Solicitation.

**2.4. "Director"** means the Director of the West Virginia Department of Administration, Purchasing Division.

**2.5. "Purchasing Division"** means the West Virginia Department of Administration, Purchasing Division.

**2.6. "Award Document"** means the document signed by the Agency and the Purchasing Division, and approved as to form by the Attorney General, that identifies the Vendor as the contract holder.

**2.7. "Solicitation"** means the official notice of an opportunity to supply the State with goods or services that is published by the Purchasing Division.

**2.8. "State"** means the State of West Virginia and/or any of its agencies, commissions, boards, etc. as context requires.

**2.9. "Vendor" or "Vendors"** means any entity submitting a bid in response to the Solicitation, the entity that has been selected as the lowest responsible bidder, or the entity that has been awarded the Contract as context requires.

**3. CONTRACT TERM; RENEWAL; EXTENSION:** The term of this Contract shall be determined in accordance with the category that has been identified as applicable to this Contract below:

**Term Contract**

**Initial Contract Term:** This Contract becomes effective on \_\_\_\_\_  
upon award \_\_\_\_\_ and extends for a period of \_\_\_\_\_ one (1) \_\_\_\_\_ year(s).

**Renewal Term:** This Contract may be renewed upon the mutual written consent of the Agency, and the Vendor, with approval of the Purchasing Division and the Attorney General's office (Attorney General approval is as to form only). Any request for renewal should be submitted to the Purchasing Division thirty (30) days prior to the expiration date of the initial contract term or appropriate renewal term. A Contract renewal shall be in accordance with the terms and conditions of the original contract. Renewal of this Contract is limited to \_\_\_\_\_ three (3) \_\_\_\_\_ successive one (1) year periods or multiple renewal periods of less than one year, provided that the multiple renewal periods do not exceed ~~thirty-six (36)~~ \_\_\_\_\_ months in total. Automatic renewal of this Contract is prohibited. Notwithstanding the foregoing, Purchasing Division approval is not required on agency delegated or exempt purchases. Attorney General approval may be required for vendor terms and conditions.

**Delivery Order Limitations:** In the event that this contract permits delivery orders, a delivery order may only be issued during the time this Contract is in effect. Any delivery order issued within one year of the expiration of this Contract shall be effective for one year from the date the delivery order is issued. No delivery order may be extended beyond one year after this Contract has expired.

**Fixed Period Contract:** This Contract becomes effective upon Vendor's receipt of the notice to proceed and must be completed within \_\_\_\_\_ days.

**Fixed Period Contract with Renewals:** This Contract becomes effective upon Vendor's receipt of the notice to proceed and part of the Contract more fully described in the attached specifications must be completed within \_\_\_\_\_ days.

Upon completion, the vendor agrees that maintenance, monitoring, or warranty services will be provided for one year thereafter with an additional \_\_\_\_\_ successive one year renewal periods or multiple renewal periods of less than one year provided that the multiple renewal periods do not exceed \_\_\_\_\_ months in total. Automatic renewal of this Contract is prohibited.

**One Time Purchase:** The term of this Contract shall run from the issuance of the Award Document until all of the goods contracted for have been delivered, but in no event will this Contract extend for more than one fiscal year.

**Other:** See attached.

**4. NOTICE TO PROCEED:** Vendor shall begin performance of this Contract immediately upon receiving notice to proceed unless otherwise instructed by the Agency. Unless otherwise specified, the fully executed Award Document will be considered notice to proceed.

**5. QUANTITIES:** The quantities required under this Contract shall be determined in accordance with the category that has been identified as applicable to this Contract below.

**Open End Contract:** Quantities listed in this Solicitation are approximations only, based on estimates supplied by the Agency. It is understood and agreed that the Contract shall cover the quantities actually ordered for delivery during the term of the Contract, whether more or less than the quantities shown.

**Service:** The scope of the service to be provided will be more clearly defined in the specifications included herewith.

**Combined Service and Goods:** The scope of the service and deliverable goods to be provided will be more clearly defined in the specifications included herewith.

**One Time Purchase:** This Contract is for the purchase of a set quantity of goods that are identified in the specifications included herewith. Once those items have been delivered, no additional goods may be procured under this Contract without an appropriate change order approved by the Vendor, Agency, Purchasing Division, and Attorney General's office.

**6. EMERGENCY PURCHASES:** The Purchasing Division Director may authorize the Agency to purchase goods or services in the open market that Vendor would otherwise provide under this Contract if those goods or services are for immediate or expedited delivery in an emergency. Emergencies shall include, but are not limited to, delays in transportation or an unanticipated increase in the volume of work. An emergency purchase in the open market, approved by the Purchasing Division Director, shall not constitute of breach of this Contract and shall not entitle the Vendor to any form of compensation or damages. This provision does not excuse the State from fulfilling its obligations under a One Time Purchase contract.

**7. REQUIRED DOCUMENTS:** All of the items checked below must be provided to the Purchasing Division by the Vendor as specified below.

**BID BOND (Construction Only):** Pursuant to the requirements contained in W. Va. Code § 5-22-1(c), All Vendors submitting a bid on a construction project shall furnish a valid bid bond in the amount of five percent (5%) of the total amount of the bid protecting the State of West Virginia. The bid bond must be submitted with the bid.

**PERFORMANCE BOND:** The apparent successful Vendor shall provide a performance bond in the amount of \_\_\_\_\_. The performance bond must be received by the Purchasing Division prior to Contract award. On construction contracts, the performance bond must be 100% of the Contract value.

**LABOR/MATERIAL PAYMENT BOND:** The apparent successful Vendor shall provide a labor/material payment bond in the amount of 100% of the Contract value. The labor/material payment bond must be delivered to the Purchasing Division prior to Contract award.

In lieu of the Bid Bond, Performance Bond, and Labor/Material Payment Bond, the Vendor may provide certified checks, cashier's checks, or irrevocable letters of credit. Any certified check, cashier's check, or irrevocable letter of credit provided in lieu of a bond must be of the same amount and delivered on the same schedule as the bond it replaces. A letter of credit submitted in lieu of a performance and labor/material payment bond will only be allowed for projects under \$100,000. Personal or business checks are not acceptable. Notwithstanding the foregoing, West Virginia Code § 5-22-1 (d) mandates that a vendor provide a performance and labor/material payment bond for construction projects. Accordingly, substitutions for the performance and labor/material payment bonds for construction projects is not permitted.

**MAINTENANCE BOND:** The apparent successful Vendor shall provide a two (2) year maintenance bond covering the roofing system. The maintenance bond must be issued and delivered to the Purchasing Division prior to Contract award.

**LICENSE(S) / CERTIFICATIONS / PERMITS:** In addition to anything required under the Section entitled Licensing, of the General Terms and Conditions, the apparent successful Vendor shall furnish proof of the following licenses, certifications, and/or permits prior to Contract award, in a form acceptable to the Purchasing Division.

The apparent successful Vendor shall also furnish proof of any additional licenses or certifications contained in the specifications prior to Contract award regardless of whether or not that requirement is listed above.



**8. INSURANCE:** The apparent successful Vendor shall furnish proof of the insurance identified by a checkmark below prior to Contract award. Subsequent to contract award, and prior to the insurance expiration date, Vendor shall provide the Agency with proof that the insurance mandated herein has been continued. Vendor must also provide Agency with immediate notice of any changes in its insurance policies mandated herein, including but not limited to, policy cancelation, policy reduction, or change in insurers. The insurance coverages identified below must be maintained throughout the life of this contract. The apparent successful Vendor shall also furnish proof of any additional insurance requirements contained in the specifications prior to Contract award regardless of whether or not that insurance requirement is listed in this section.

Vendor must maintain:

**Commercial General Liability Insurance** in at least an amount of:  
\_\_\_\_\_  
\_\_\_\_\_

**Automobile Liability Insurance** in at least an amount of: \_\_\_\_\_

**Professional/Malpractice/Errors and Omission Insurance** in at least an amount of:  
\_\_\_\_\_

**Commercial Crime and Third Party Fidelity Insurance** in an amount of:  
\_\_\_\_\_  
\_\_\_\_\_

**Cyber Liability Insurance** in an amount of: \_\_\_\_\_

**Builders Risk Insurance** in an amount equal to 100% of the amount of the Contract.

**9. WORKERS' COMPENSATION INSURANCE:** The apparent successful Vendor shall comply with laws relating to workers compensation, shall maintain workers' compensation insurance when required, and shall furnish proof of workers' compensation insurance upon request.

**10. LITIGATION BOND:** The Director reserves the right to require any Vendor that files a protest of an award to submit a litigation bond in the amount equal to one percent of the lowest bid submitted or \$5,000, whichever is greater. The entire amount of the bond shall be forfeited if the hearing officer determines that the protest was filed for frivolous or improper purpose, including but not limited to, the purpose of harassing, causing unnecessary delay, or needless expense for the Agency. All litigation bonds shall be made payable to the Purchasing Division. In lieu of a bond, the protester may submit a cashier's check or certified check payable to the Purchasing Division. Cashier's or certified checks will be deposited with and held by the State Treasurer's office. If it is determined that the protest has not been filed for frivolous or improper purpose, the bond or deposit shall be returned in its entirety.

**11. LIQUIDATED DAMAGES:** Vendor shall pay liquidated damages in the amount of n/a for n/a.

This clause shall in no way be considered exclusive and shall not limit the State or Agency's right to pursue any other available remedy.

**12. ACCEPTANCE:** Vendor's signature on its bid, or on the certification and signature page, constitutes an offer to the State that cannot be unilaterally withdrawn, signifies that the product or service proposed by vendor meets the mandatory requirements contained in the Solicitation for that product or service, unless otherwise indicated, and signifies acceptance of the terms and conditions contained in the Solicitation unless otherwise indicated.

**13. PRICING:** The pricing set forth herein is firm for the life of the Contract, unless specified elsewhere within this Solicitation/Contract by the State. A Vendor's inclusion of price adjustment provisions in its bid, without an express authorization from the State in the Solicitation to do so, may result in bid disqualification.

**14. PAYMENT:** Payment in advance is prohibited under this Contract. Payment may only be made after the delivery and acceptance of goods or services. The Vendor shall submit invoices, in arrears.

**15. PURCHASING CARD ACCEPTANCE:** The State of West Virginia currently utilizes a Purchasing Card program, administered under contract by a banking institution, to process payment for goods and services. The Vendor must accept the State of West Virginia's Purchasing Card for payment of all orders under this Contract unless the box below is checked.

Vendor is not required to accept the State of West Virginia's Purchasing Card as payment for all goods and services.

**16. TAXES:** The Vendor shall pay any applicable sales, use, personal property or any other taxes arising out of this Contract and the transactions contemplated thereby. The State of West Virginia is exempt from federal and state taxes and will not pay or reimburse such taxes.

**17. ADDITIONAL FEES:** Vendor is not permitted to charge additional fees or assess additional charges that were not either expressly provided for in the solicitation published by the State of West Virginia or included in the unit price or lump sum bid amount that Vendor is required by the solicitation to provide. Including such fees or charges as notes to the solicitation may result in rejection of vendor's bid. Requesting such fees or charges be paid after the contract has been awarded may result in cancellation of the contract.

**18. FUNDING:** This Contract shall continue for the term stated herein, contingent upon funds being appropriated by the Legislature or otherwise being made available. In the event funds are not appropriated or otherwise made available, this Contract becomes void and of no effect beginning on July 1 of the fiscal year for which funding has not been appropriated or otherwise made available.

**19. CANCELLATION:** The Purchasing Division Director reserves the right to cancel this Contract immediately upon written notice to the vendor if the materials or workmanship supplied do not conform to the specifications contained in the Contract. The Purchasing Division Director may also cancel any purchase or Contract upon 30 days written notice to the Vendor in accordance with West Virginia Code of State Rules § 148-1-6.1.e.

**20. TIME:** Time is of the essence with regard to all matters of time and performance in this Contract.

**21. APPLICABLE LAW:** This Contract is governed by and interpreted under West Virginia law without giving effect to its choice of law principles. Any information provided in specification manuals, or any other source, verbal or written, which contradicts or violates the West Virginia Constitution, West Virginia Code or West Virginia Code of State Rules is void and of no effect.

**22. COMPLIANCE:** Vendor shall comply with all applicable federal, state, and local laws, regulations and ordinances. By submitting a bid, Vendor acknowledges that it has reviewed, understands, and will comply with all applicable laws, regulations, and ordinances.

**23. ARBITRATION:** Any references made to arbitration contained in this Contract, Vendor's bid, or in any American Institute of Architects documents pertaining to this Contract are hereby deleted, void, and of no effect.

**24. MODIFICATIONS:** This writing is the parties' final expression of intent. Notwithstanding anything contained in this Contract to the contrary no modification of this Contract shall be binding without mutual written consent of the Agency, and the Vendor, with approval of the Purchasing Division and the Attorney General's office (Attorney General approval is as to form only). Any change to existing contracts that adds work or changes contract cost, and were not included in the original contract, must be approved by the Purchasing Division and the Attorney General's Office (as to form) prior to the implementation of the change or commencement of work affected by the change.

Revised 04/07/2017

**25. WAIVER:** The failure of either party to insist upon a strict performance of any of the terms or provision of this Contract, or to exercise any option, right, or remedy herein contained, shall not be construed as a waiver or a relinquishment for the future of such term, provision, option, right, or remedy, but the same shall continue in full force and effect. Any waiver must be expressly stated in writing and signed by the waiving party.

**26. SUBSEQUENT FORMS:** The terms and conditions contained in this Contract shall supersede any and all subsequent terms and conditions which may appear on any form documents submitted by Vendor to the Agency or Purchasing Division such as price lists, order forms, invoices, sales agreements, or maintenance agreements, and includes internet websites or other electronic documents. Acceptance or use of Vendor's forms does not constitute acceptance of the terms and conditions contained thereon.

**27. ASSIGNMENT:** Neither this Contract nor any monies due, or to become due hereunder, may be assigned by the Vendor without the express written consent of the Agency, the Purchasing Division, the Attorney General's office (as to form only), and any other government agency or office that may be required to approve such assignments. Notwithstanding the foregoing, Purchasing Division approval may or may not be required on certain agency delegated or exempt purchases.

**28. WARRANTY:** The Vendor expressly warrants that the goods and/or services covered by this Contract will: (a) conform to the specifications, drawings, samples, or other description furnished or specified by the Agency; (b) be merchantable and fit for the purpose intended; and (c) be free from defect in material and workmanship.

**29. STATE EMPLOYEES:** State employees are not permitted to utilize this Contract for personal use and the Vendor is prohibited from permitting or facilitating the same.

**30. BANKRUPTCY:** In the event the Vendor files for bankruptcy protection, the State of West Virginia may deem this Contract null and void, and terminate this Contract without notice.

**31. PRIVACY, SECURITY, AND CONFIDENTIALITY:** The Vendor agrees that it will not disclose to anyone, directly or indirectly, any such personally identifiable information or other confidential information gained from the Agency, unless the individual who is the subject of the information consents to the disclosure in writing or the disclosure is made pursuant to the Agency's policies, procedures, and rules. Vendor further agrees to comply with the Confidentiality Policies and Information Security Accountability Requirements, set forth in <http://www.state.wv.us/admin/purchase/privacy/default.html>.

**32. YOUR SUBMISSION IS A PUBLIC DOCUMENT:** Vendor's entire response to the Solicitation and the resulting Contract are public documents. As public documents, they will be disclosed to the public following the bid/proposal opening or award of the contract, as required by the competitive bidding laws of West Virginia Code §§ 5A-3-1 et seq., 5-22-1 et seq., and 5G-1-1 et seq. and the Freedom of Information Act West Virginia Code §§ 29B-1-1 et seq.

**DO NOT SUBMIT MATERIAL YOU CONSIDER TO BE CONFIDENTIAL, A TRADE SECRET, OR OTHERWISE NOT SUBJECT TO PUBLIC DISCLOSURE.**

Submission of any bid, proposal, or other document to the Purchasing Division constitutes your explicit consent to the subsequent public disclosure of the bid, proposal, or document. The Purchasing Division will disclose any document labeled "confidential," "proprietary," "trade secret," "private," or labeled with any other claim against public disclosure of the documents, to include any "trade secrets" as defined by West Virginia Code § 47-22-1 et seq. All submissions are subject to public disclosure without notice.

**33. LICENSING:** In accordance with West Virginia Code of State Rules § 148-1-6.1.e, Vendor must be licensed and in good standing in accordance with any and all state and local laws and requirements by any state or local agency of West Virginia, including, but not limited to, the West Virginia Secretary of State's Office, the West Virginia Tax Department, West Virginia Insurance Commission, or any other state agency or political subdivision. Upon request, the Vendor must provide all necessary releases to obtain information to enable the Purchasing Division Director or the Agency to verify that the Vendor is licensed and in good standing with the above entities.

**34. ANTITRUST:** In submitting a bid to, signing a contract with, or accepting a Award Document from any agency of the State of West Virginia, the Vendor agrees to convey, sell, assign, or transfer to the State of West Virginia all rights, title, and interest in and to all causes of action it may now or hereafter acquire under the antitrust laws of the United States and the State of West Virginia for price fixing and/or unreasonable restraints of trade relating to the particular commodities or services purchased or acquired by the State of West Virginia. Such assignment shall be made and become effective at the time the purchasing agency tenders the initial payment to Vendor.

**35. VENDOR CERTIFICATIONS:** By signing its bid or entering into this Contract, Vendor certifies (1) that its bid or offer was made without prior understanding, agreement, or connection with any corporation, firm, limited liability company, partnership, person or entity submitting a bid or offer for the same material, supplies, equipment or services; (2) that its bid or offer is in all respects fair and without collusion or fraud; (3) that this Contract is accepted or entered into without any prior understanding, agreement, or connection to any other entity that could be considered a violation of law; and (4) that it has reviewed this Solicitation in its entirety; understands the requirements, terms and conditions, and other information contained herein.

Vendor's signature on its bid or offer also affirms that neither it nor its representatives have any interest, nor shall acquire any interest, direct or indirect, which would compromise the performance of its services hereunder. Any such interests shall be promptly presented in detail to the Agency. The individual signing this bid or offer on behalf of Vendor certifies that he or she is authorized by the Vendor to execute this bid or offer or any documents related thereto on Vendor's behalf; that he or she is authorized to bind the Vendor in a contractual relationship; and that, to the best of his or her knowledge, the Vendor has properly registered with any State agency that may require registration.

**36. VENDOR RELATIONSHIP:** The relationship of the Vendor to the State shall be that of an independent contractor and no principal-agent relationship or employer-employee relationship is contemplated or created by this Contract. The Vendor as an independent contractor is solely liable for the acts and omissions of its employees and agents. Vendor shall be responsible for selecting, supervising, and compensating any and all individuals employed pursuant to the terms of this Solicitation and resulting contract. Neither the Vendor, nor any employees or subcontractors of the Vendor, shall be deemed to be employees of the State for any purpose whatsoever. Vendor shall be exclusively responsible for payment of employees and contractors for all wages and salaries, taxes, withholding payments, penalties, fees, fringe benefits, professional liability insurance premiums, contributions to insurance and pension, or other deferred compensation plans, including but not limited to, Workers' Compensation and Social Security obligations, licensing fees, etc. and the filing of all necessary documents, forms, and returns pertinent to all of the foregoing.

Vendor shall hold harmless the State, and shall provide the State and Agency with a defense against any and all claims including, but not limited to, the foregoing payments, withholdings, contributions, taxes, Social Security taxes, and employer income tax returns.

**37. INDEMNIFICATION:** The Vendor agrees to indemnify, defend, and hold harmless the State and the Agency, their officers, and employees from and against: (1) Any claims or losses for services rendered by any subcontractor, person, or firm performing or supplying services, materials, or supplies in connection with the performance of the Contract; (2) Any claims or losses resulting to any person or entity injured or damaged by the Vendor, its officers, employees, or subcontractors by the publication, translation, reproduction, delivery, performance, use, or disposition of any data used under the Contract in a manner not authorized by the Contract, or by Federal or State statutes or regulations; and (3) Any failure of the Vendor, its officers, employees, or subcontractors to observe State and Federal laws including, but not limited to, labor and wage and hour laws.

**38. PURCHASING AFFIDAVIT:** In accordance with West Virginia Code § 5A-3-10a, all Vendors are required to sign, notarize, and submit the Purchasing Affidavit stating that neither the Vendor nor a related party owe a debt to the State in excess of \$1,000. The affidavit must be submitted prior to award, but should be submitted with the Vendor's bid. A copy of the Purchasing Affidavit is included herewith.

**39. ADDITIONAL AGENCY AND LOCAL GOVERNMENT USE:** This Contract may be utilized by other agencies, spending units, and political subdivisions of the State of West Virginia; county, municipal, and other local government bodies; and school districts (“Other Government Entities”). Any extension of this Contract to the aforementioned Other Government Entities must be on the same prices, terms, and conditions as those offered and agreed to in this Contract, provided that such extension is in compliance with the applicable laws, rules, and ordinances of the Other Government Entity. If the Vendor does not wish to extend the prices, terms, and conditions of its bid and subsequent contract to the Other Government Entities, the Vendor must clearly indicate such refusal in its bid. A refusal to extend this Contract to the Other Government Entities shall not impact or influence the award of this Contract in any manner.

**40. CONFLICT OF INTEREST:** Vendor, its officers or members or employees, shall not presently have or acquire an interest, direct or indirect, which would conflict with or compromise the performance of its obligations hereunder. Vendor shall periodically inquire of its officers, members and employees to ensure that a conflict of interest does not arise. Any conflict of interest discovered shall be promptly presented in detail to the Agency.

**41. REPORTS:** Vendor shall provide the Agency and/or the Purchasing Division with the following reports identified by a checked box below:

Such reports as the Agency and/or the Purchasing Division may request. Requested reports may include, but are not limited to, quantities purchased, agencies utilizing the contract, total contract expenditures by agency, etc.

Quarterly reports detailing the total quantity of purchases in units and dollars, along with a listing of purchases by agency. Quarterly reports should be delivered to the Purchasing Division via email at [purchasing.requisitions@wv.gov](mailto:purchasing.requisitions@wv.gov).

**42. BACKGROUND CHECK:** In accordance with W. Va. Code § 15-2D-3, the Director of the Division of Protective Services shall require any service provider whose employees are regularly employed on the grounds or in the buildings of the Capitol complex or who have access to sensitive or critical information to submit to a fingerprint-based state and federal background inquiry through the state repository. The service provider is responsible for any costs associated with the fingerprint-based state and federal background inquiry.

After the contract for such services has been approved, but before any such employees are permitted to be on the grounds or in the buildings of the Capitol complex or have access to sensitive or critical information, the service provider shall submit a list of all persons who will be physically present and working at the Capitol complex to the Director of the Division of Protective Services for purposes of verifying compliance with this provision. The State reserves the right to prohibit a service provider’s employees from accessing sensitive or critical information or to be present at the Capitol complex based upon results addressed from a criminal background check.

Service providers should contact the West Virginia Division of Protective Services by phone at (304) 558-9911 for more information.

**43. PREFERENCE FOR USE OF DOMESTIC STEEL PRODUCTS:** Except when authorized by the Director of the Purchasing Division pursuant to W. Va. Code § 5A-3-56, no contractor may use or supply steel products for a State Contract Project other than those steel products made in the United States. A contractor who uses steel products in violation of this section may be subject to civil penalties pursuant to W. Va. Code § 5A-3-56. As used in this section:

a. "State Contract Project" means any erection or construction of, or any addition to, alteration of or other improvement to any building or structure, including, but not limited to, roads or highways, or the installation of any heating or cooling or ventilating plants or other equipment, or the supply of and materials for such projects, pursuant to a contract with the State of West Virginia for which bids were solicited on or after June 6, 2001.

b. "Steel Products" means products rolled, formed, shaped, drawn, extruded, forged, cast, fabricated or otherwise similarly processed, or processed by a combination of two or more or such operations, from steel made by the open heath, basic oxygen, electric furnace, Bessemer or other steel making process. The Purchasing Division Director may, in writing, authorize the use of foreign steel products if:

c. The cost for each contract item used does not exceed one tenth of one percent (.1%) of the total contract cost or two thousand five hundred dollars (\$2,500.00), whichever is greater. For the purposes of this section, the cost is the value of the steel product as delivered to the project; or

d. The Director of the Purchasing Division determines that specified steel materials are not produced in the United States in sufficient quantity or otherwise are not reasonably available to meet contract requirements.



**44. PREFERENCE FOR USE OF DOMESTIC ALUMINUM, GLASS, AND STEEL:** In Accordance with W. Va. Code § 5-19-1 et seq., and W. Va. CSR § 148-10-1 et seq., for every contract or subcontract, subject to the limitations contained herein, for the construction, reconstruction, alteration, repair, improvement or maintenance of public works or for the purchase of any item of machinery or equipment to be used at sites of public works, only domestic aluminum, glass or steel products shall be supplied unless the spending officer determines, in writing, after the receipt of offers or bids, (1) that the cost of domestic aluminum, glass or steel products is unreasonable or inconsistent with the public interest of the State of West Virginia, (2) that domestic aluminum, glass or steel products are not produced in sufficient quantities to meet the contract requirements, or (3) the available domestic aluminum, glass, or steel do not meet the contract specifications. This provision only applies to public works contracts awarded in an amount more than fifty thousand dollars (\$50,000) or public works contracts that require more than ten thousand pounds of steel products.

The cost of domestic aluminum, glass, or steel products may be unreasonable if the cost is more than twenty percent (20%) of the bid or offered price for foreign made aluminum, glass, or steel products. If the domestic aluminum, glass or steel products to be supplied or produced in a “substantial labor surplus area”, as defined by the United States Department of Labor, the cost of domestic aluminum, glass, or steel products may be unreasonable if the cost is more than thirty percent (30%) of the bid or offered price for foreign made aluminum, glass, or steel products. This preference shall be applied to an item of machinery or equipment, as indicated above, when the item is a single unit of equipment or machinery manufactured primarily of aluminum, glass or steel, is part of a public works contract and has the sole purpose or of being a permanent part of a single public works project. This provision does not apply to equipment or machinery purchased by a spending unit for use by that spending unit and not as part of a single public works project.

All bids and offers including domestic aluminum, glass or steel products that exceed bid or offer prices including foreign aluminum, glass or steel products after application of the preferences provided in this provision may be reduced to a price equal to or lower than the lowest bid or offer price for foreign aluminum, glass or steel products plus the applicable preference. If the reduced bid or offer prices are made in writing and supersede the prior bid or offer prices, all bids or offers, including the reduced bid or offer prices, will be reevaluated in accordance with this rule.

**DESIGNATED CONTACT:** Vendor appoints the individual identified in this Section as the Contract Administrator and the initial point of contact for matters relating to this Contract.

  
\_\_\_\_\_  
(Name, Title)  
Steve Lewis, Bobcat Specialist  
\_\_\_\_\_  
(Printed Name and Title)  
614 New Goff Mt. Road, Cross Lanes, WV 25313  
\_\_\_\_\_  
(Address)  
304-776-9100/304-776-0285  
\_\_\_\_\_  
(Phone Number) / (Fax Number)  
stevelewis@jefferds.com  
\_\_\_\_\_  
(email address)

**CERTIFICATION AND SIGNATURE:** By signing below, or submitting documentation through wvOASIS, I certify that I have reviewed this Solicitation in its entirety; that I understand the requirements, terms and conditions, and other information contained herein; that this bid, offer or proposal constitutes an offer to the State that cannot be unilaterally withdrawn; that the product or service proposed meets the mandatory requirements contained in the Solicitation for that product or service, unless otherwise stated herein; that the Vendor accepts the terms and conditions contained in the Solicitation, unless otherwise stated herein; that I am submitting this bid, offer or proposal for review and consideration; that I am authorized by the vendor to execute and submit this bid, offer, or proposal, or any documents related thereto on vendor's behalf; that I am authorized to bind the vendor in a contractual relationship; and that to the best of my knowledge, the vendor has properly registered with any State agency that may require registration.

\_\_\_\_\_  
Jefferds Corporation dba Bobcat of Advantage Valley  
(Company)

  
\_\_\_\_\_  
(Authorized Signature) (Representative Name, Title)

\_\_\_\_\_  
Steve Lewis, Bobcat Specialist  
(Printed Name and Title of Authorized Representative)

\_\_\_\_\_  
8-16-17  
(Date)

\_\_\_\_\_  
304-776-9100/304-776-0285  
(Phone Number) (Fax Number)

CRFQ 0803 DOT1700000086  
REQUEST FOR QUOTATION  
**HYDRAULIC COMPACT TRACK EXCAVATOR**  
With Swivel Head, Digging Bucket, Ditching Bucket, Thumb

---

**SPECIFICATIONS**

1. **PURPOSE AND SCOPE:** The West Virginia Purchasing Division is soliciting bids on behalf of the West Virginia Division of Highways (WVDOH), the West Virginia Department of Transportation (WVDOT), to establish an open-end contract for a Hydraulic Compact Track Excavators.
  
2. **DEFINITIONS:** The terms listed below shall have the meanings assigned to them below. Additional definitions can be found in section 2 of the General Terms and Conditions.
  - 2.1 **“Contract Item” or “Contract Items”** means the list of items identified in Section 3, Subsection 1 below.
  - 2.2 **“Pricing Pages”** means the schedule of prices, estimated order quantity, and totals contained in wvOASIS or attached hereto as Exhibit A, and used to evaluate the Solicitation responses.
  - 2.3 **“Solicitation”** means the official notice of an opportunity to supply the State with goods or services that is published by the Purchasing Division.
  - 2.4 **“WVDOH”** means West Virginia Division of Highways.
  - 2.5 **“GPM”** means gallons per minute.
  - 2.6 **“TOPS”** means tip over protection cover.
  - 2.7 **“ROPS”** means Roll- over protection structure.
  - 2.8 **“FLOPS”** means falling object protection structure.
  - 2.9 **“OEM”** means original equipment manufacturer.
  
3. **GENERAL REQUIREMENTS:**
  - 3.1 **Contract Items and Mandatory Requirements:** Vendor shall provide Agency with the Contract Items listed below on an open-end and continuing basis. Contract Items must meet or exceed the mandatory requirements as shown below.

CRFQ 0803 DOT1700000086  
REQUEST FOR QUOTATION  
**HYDRAULIC COMPACT TRACK EXCAVATOR**  
**With Swivel Head, Digging Bucket, Ditching Bucket, Thumb**

---

**3.1.1 Hydraulic Compact Excavator with Swivel Head, Digging Bucket, Ditching Bucket, Hydraulic Thumb.**

**3.1.1.1** Operating weight shall be minimum 11,500 pounds including thumb, blade, swivel and bucket.

**3.1.1.2** The unit specified herein and offered shall be manufactured on or after January 1, 2017 and will be clearly identified and marked with date of manufacture.

**3.1.2 Engine:**

**3.1.2.1** Engine shall be 35 horsepower minimum; diesel engine, liquid cooled.

**3.1.2.2** Engine shall include the following characteristics;  
A. Fuel water separator filter factory installed.  
B. 12-volt system  
C. Electric fuel priming pump  
D. Automatic idle system.

**3.1.3 Powertrain**

**3.1.3.1** Shall have minimum of one (1) high and a minimum of one (1) low travel speed.

**3.1.4 Hydraulic System:**

**3.1.4.1** Shall have hydraulic system that will accept different attachments and maintain safe oil temperature within manufacturers recommended operation range during continuous operation under maximum working combinations.

**3.1.4.2** Unit shall be equipped with a factory installed hydraulic thumb.

CRFQ 0803 DOT1700000086  
REQUEST FOR QUOTATION  
**HYDRAULIC COMPACT TRACK EXCAVATOR**  
With Swivel Head, Digging Bucket, Ditching Bucket, Thumb

---

**3.1.4.3** Drive shall be hydrostatic design with independent track control.

**3.1.4.4** Swing brake shall be wet-disc type.

**3.1.4.5** Unit shall be joystick controlled with a minimum of one (1) additional actuator for auxiliary hydraulics.

**3.1.4.6** Unit shall have control pattern-change valve.

**3.1.4.7** Unit shall have auxiliary hydraulic valve section.

**3.1.4.8** Unit shall have auxiliary hydraulic lines with quick couplers and a 3-way hydraulic valve to switch from swivel head to thumb.

**3.1.4.9** Unit shall have auxiliary work tool flow control adjustment capabilities.

**3.1.5 Undercarriage:**

**3.1.5.1** Undercarriage frame shall be manufacturers standard for model bid, and shall include:

- A. Rubber tracks minimum of 16 inches wide.
- B. Track guides to prevent track misalignment
- C. Track adjustment shall be of hydraulic design
- D. Belly pan guard.
- E. Undercarriage with manufacturer's standard size hydraulic blade for model bid, with float.

**3.1.6 Cab:**

**3.1.6.1** Shall be all weather steel cab with ROPS/TOPS/FLOPS with all-round visibility.

**3.1.6.2** Unit shall have a cloth suspension seat with padded arm rest.

CRFQ 0803 DOT1700000086  
REQUEST FOR QUOTATION  
**HYDRAULIC COMPACT TRACK EXCAVATOR**  
With Swivel Head, Digging Bucket, Ditching Bucket, Thumb

---

**3.1.6.3** Cab shall be equipped with manufacturers' heater and air-conditioning system.

**3.1.6.4** Cab shall be equipped with front windshield wiper and washer.

**3.1.6.5** Manufacturer's vandalism protection package shall be provided. The vandalism protection package shall include locking cab-doors, locking compartments for engine and hydraulic components, locking fuel and radiator access and electrical cut-off switch. All locks except master switch shall be keyed alike.

**3.1.6.6** The following shall be included for cab area:

- A. Interior cab light
- B. Two work lights, one at boom and one on cab.
- C. AM and FM radio with antenna
- D. Shall have motion alarm with cancel switch
- E. Horn.
- F. One 12-volt accessory outlet.
- G. Complete engine monitoring system.
- H. Rear secondary exit kit.
- I. Shall be wired for smart link capabilities.
- J. Cab mirrors

**3.1.7** **Maximum Reach and Digging Depth**

**3.1.7.1** Unit bid shall have minimum digging depth of 12 foot and a minimum digging reach of 20 foot.

**3.1.8** **Counterweight**

**3.1.8.1** Unit shall include the maximum available counterweight for unit bid.

CRFQ 0803 DOT1700000086  
REQUEST FOR QUOTATION  
**HYDRAULIC COMPACT TRACK EXCAVATOR**  
With Swivel Head, Digging Bucket, Ditching Bucket, Thumb

---

**3.1.9 Tilting Coupler/Swivel**

**3.1.9.1** Unit shall include a hydraulic tilting coupler/swivel.

**3.1.9.2** Total tilt range 134 degrees minimum.

**3.1.9.3** Shall allow for use of OEM bucket

**3.1.9.4** Shall include integral quick coupler.

**3.1.10 Bucket**

**3.1.10.1** Unit shall include a 40-inch minimum smooth ditching bucket.

**3.1.10.2** Unit shall include a 24-inch digging bucket with replaceable teeth.

**3.1.10.3** Both buckets shall be quick coupler style.

**3.1.11 Compact Excavator Paint:**

**3.1.11.1** Unit shall be painted manufacturers standard color.

**4. CONTRACT AWARD:**

**4.1 Contract Award:** The Contract is intended to provide Agencies with a purchase price on all Contract Items. The Contract shall be awarded to the Vendor that provides the Contract Items meeting the required specifications for the lowest overall total cost.

**4.2 Pricing Pages:** Vendor must complete the Exhibit\_A Pricing Page by entering the Unit Price for the commodity requested. The pricing page is provided in an Excel format and will automatically calculate the Total price and Grand Total price when the Unit Price is entered. However, it is the

CRFQ 0803 DOT1700000086  
REQUEST FOR QUOTATION  
**HYDRAULIC COMPACT TRACK EXCAVATOR**  
With Swivel Head, Digging Bucket, Ditching Bucket, Thumb

---

Vendor's responsibility to ensure the calculations for their bid is correct before submitting. Vendor must complete the Pricing Page in its entirety as failure to do so may result in Vendor's bids being disqualified.

The Pricing Pages contain a list of the Contract Items and estimated purchase volume. The estimated purchase volume for each item represents the approximate volume of anticipated purchases only. No future use of the Contract or any individual item is guaranteed or implied.

Vendor should electronically enter the information into the Pricing Pages through wvOASIS, if available, or as an electronic document. In most cases, the Vendor can request an electronic copy of the Pricing Pages for bid purposes by sending an email request to the following address: [Mark.A.Atkins@wv.gov](mailto:Mark.A.Atkins@wv.gov).

**5. ORDERING AND PAYMENT:**

- 5.1 Ordering:** Vendor shall accept orders by regular mail, facsimile, e-mail, or any other written forms of communication.
- 5.2 Payment:** Vendor shall accept payment in accordance with the payment procedures of the State of West Virginia.

**6. DELIVERY AND RETURN:**

- 6.1 Delivery Time:** Vendor shall deliver standard orders within **120** working days after orders are received. Vendor shall ship all orders in accordance with the above schedule and shall not hold orders until a minimum delivery quantity is met. A completed pilot model for inspection must be provided within **90** working day(s) after receipt of the purchase agreement by the successful vendor. Working day is defined as any week day, Monday thru Friday, excluding Federal and State Holidays.
- 6.2 Late Delivery:** The Agency placing the order under this Contract must be notified in writing if orders will be delayed for any reason. Any delay in delivery that could cause harm to an Agency will be grounds for cancellation of the delayed order, and/or obtaining the items ordered from a third party.

Any Agency seeking to obtain items from a third party under this provision must first obtain approval of the Purchasing Division.



CRFQ 0803 DOT170000086  
REQUEST FOR QUOTATION  
**HYDRAULIC COMPACT TRACK EXCAVATOR**  
With Swivel Head, Digging Bucket, Ditching Bucket, Thumb

---

- 6.3 Delivery Payment/Risk of Loss:** Standard order delivery shall be F.O.B. destination to the Agency's location. Vendor shall include the cost of standard order delivery charges in its bid pricing/discount and is not permitted to charge the Agency separately for such delivery.
- 6.4 Representative Unit for Test:** The successful vendor must (if specified) provide the DOH one (1) completed represented unit to be observed and evaluated on each order to insure compliance with specification. If requested, the time period for testing and evaluation shall be seven (7) working days following receipt of the unit. DOH will incur no obligation for deterioration of surfaces, finishes, seals, and mechanical or electrical parts on the unit resulting from operation and testing within the limits of these specifications; nor will DOH incur obligation for damage to the unit resulting from failure to meet specifications when due care and attention is given by DOH and testing is done within the limits of these specifications. Failure of the pilot unit to satisfactorily meet specifications as bid may be cause for cancellation of the purchase order, and return of the delivered unit along with all associated equipment to the vendor at the vendor's expense.
- 6.5 Condition of Unit(s) Upon Delivery:** All units must arrive at the prescribed delivery point having been completely pre-serviced with oil, lubricants, and coolant. All prescribed precautions pertaining to first operations and break-in of the unit are to be posted conspicuously on the unit for ready observance by the operator.
- 6.6 Delivery Point:** Delivery point of the completed representative unit will be the WVDOH, Equipment Division, 83 Brushy Fork Crossing, Buckhannon, WV 26201.

**7. MISCELLANEOUS:**

- 7.1 No Substitutions:** Vendor shall supply only Contract Items submitted in response to RFQ unless a contract modification is approved in accordance with the provisions contained in this contract.
- 7.2 Reports:** Vendor shall provide quarterly reports and annual summaries to the Agency showing the Agency's items purchased, quantities of items purchased, and total dollar value of the items purchased. Vendor shall also provide reports, upon request, showing the items purchased during the term of this Contract, the quantity purchased for each of those items, and the total value of purchases for each of those items. Failure to supply such reports may be grounds for cancellation of this Contract.

CRFQ 0803 DOT1700000086  
REQUEST FOR QUOTATION  
**HYDRAULIC COMPACT TRACK EXCAVATOR**  
With Swivel Head, Digging Bucket, Ditching Bucket, Thumb

---

**7.3 Contract Manager:** During its performance of this Contract, Vendor must designate and maintain a primary contract manager responsible for overseeing Vendor's responsibilities under this Contract. The Contract manager must be available during normal business hours to address any customer service or other issues related to this Contract. Vendor should list its Contract manager and his or her contact information below.

**Contract Manager:** Steve Lewis  
**Telephone Number:** 304-776-9100  
**Fax Number:** 304-776-0285  
**Email Address:** stevelewis@jefferds.com

**7.4 Operating and Service Manuals and Parts Lists:** An operator's manual must be included with each unit upon delivery. A "line sheet" (if applicable) and the "Equipment Preventative Maintenance Questionnaire", (Exhibit "B") must be with pilot unit upon delivery, Attn: Marcia Lee. There must be 12 service/shop/maintenance manuals and 14 parts manuals; CD-ROM is preferred in lieu of parts manuals. Manuals shall be delivered upon completion of delivery of total units. Failure to do so will delay payment.

**7.5 Training:** Manufacturers and/or dealers will be required to stage a thorough seminar on the subjects of Preventative Maintenance, Operator, and Mechanic Training. In order to keep operators and mechanics updated, the successful vendor shall conduct training sessions covering the operation, maintenance, trouble-shooting with each purchase order against this open end contract. Manufacturers and/or dealers shall be required to furnish the Training Academy with one (1) Operator's Manual to be shipped direct to

**WVDOH**  
Training Academy  
P.O. Box 610  
Buckhannon, West Virginia 26201

Prior to delivery of the pilot unit. Training seminar to be held at the WVDOT, Equipment Division, Buckhannon, WV.

**7.6 Preventative Maintenance & Operator Procedures:** Manufacturers and/or dealers will be required to submit to the Equipment Division, in addition to the

CRFQ 0803 DOT1700000086  
REQUEST FOR QUOTATION  
**HYDRAULIC COMPACT TRACK EXCAVATOR**  
**With Swivel Head, Digging Bucket, Ditching Bucket, Thumb**

---

operating and service manuals, booklets and pamphlets explaining the Preventative Maintenance and Operator Procedures to be used by the operators of this equipment, and must include such things as daily prestart inspection procedure, service schedule, and routine maintenance required, safety precautions, etc. The successful vendor shall furnish all training aids; i.e. videos, projectors as required in conducting the training.

**7.7 Warranty and Service Policy:** The bid shall include a breakdown of the complete manufacturer's warranty per section. The unit must be accompanied upon delivery by the unit's manufacturers executed warranty and service policy.

**7.8 Unspecified Accessories & Features:** All parts, equipment, accessories, materials, design and performance characteristics not specified herein, but which are necessary to provide a complete unit, must be furnished with each unit and required to conform to strength, quality of material, and quality of workmanship to those which are advertised and provided to the market in general by the unit Industry. All parts and accessories advertised and regularly supplied as standard shall be included, except those which would represent duplication of these specified and except those which, by specification, are not to be furnished. All standard safety features, required by Federal and State Law, shall be included.

## **8. VENDOR DEFAULT:**

**8.1** The following shall be considered a vendor default under this Contract.

8.1.1 Failure to provide Contract Items in accordance with the requirements contained herein.

8.1.2 Failure to comply with other specifications and requirements contained herein.

8.1.3 Failure to comply with any laws, rules, and ordinances applicable to the Contract Services provided under this Contract.

8.1.4 Failure to remedy deficient performance upon request.

CRFQ 0803 DOT1700000086  
REQUEST FOR QUOTATION  
**HYDRAULIC COMPACT TRACK EXCAVATOR**  
**With Swivel Head, Digging Bucket, Ditching Bucket, Thumb**

---

**8.2** The following remedy shall be available to Agency upon default.

8.2.1 Immediate cancellation of the contract.

8.2.2 Immediate cancellation of one or more release orders issued under this Contract.

8.2.3 Any other remedies available in law or equity.



Purchasing Division  
 2019 Washington Street East  
 Post Office Box 50130  
 Charleston, WV 25305-0130

State of West Virginia  
 Request for Quotation  
 13 - Equipment

Proc Folder: 336215

Doc Description: HYDRAULIC COMPACT TRACK EXCAVATOR

Proc Type: Central Master Agreement

Date Issued	Solicitation Closes	Solicitation No	Version
2017-06-05	2017-06-28 13:30:00	CRFQ 0803 DOT1700000086	1

**BID RECEIVING LOCATION**

BID CLERK  
 DEPARTMENT OF ADMINISTRATION  
 PURCHASING DIVISION  
 2019 WASHINGTON ST E  
 CHARLESTON WV 25305  
 US

**VENDOR**

Vend  **Bobcat.**  
**Of Advantage Valley**  
 A Division of Jefferds Corporation  
 614 New Goff Mountain Road  
 Cross Lanes WV 25313

304-776-9100

**FOR INFORMATION CONTACT THE BUYER**

Mark A Atkins  
 (304) 558-2307  
 mark.a.atkins@wv.gov

Signature X 

FEIN # 55-0336065

DATE 8-16-17

All offers subject to all terms and conditions contained in this solicitation

**ADDITIONAL INFORMATION**

The West Virginia Purchasing Division is soliciting bids on behalf of the West Virginia Division of Highways (WVDOH), the West Virginia Department of Transportation (WVDOT), to establish an open-end contract for Hydraulic Compact Track Excavators per the attached documents.

**MANDATORY PRE-BID MEETING:**

A Mandatory Pre-Bid Meeting will be held on:

DATE: June 15, 2017  
 TIME: 10:00am EST  
 LOCATION: WVDOH  
 Equipment Division  
 83 Brushy Fork Crossing  
 Buckhannon, WV 26201

INVOICE TO	SHIP TO
DIVISION OF HIGHWAYS EQUIPMENT DIVISION RT 33 83 BRUSHY ROAD CROSSING, PO BOX 610 BUCKHANNON WV26201 US	DIVISION OF HIGHWAYS EQUIPMENT DIVISION 83 BRUSHY FORK RD CROSSING BUCKHANNON WV 26201 US

Line	Comm Ln Desc	Qty	Unit Issue	Unit Price	Total Price
1	Pricing shall be completed on Exhibit A Pricing Page.	0.00000	EA		

Comm Code	Manufacturer	Specification	Model #
22101526			

**Extended Description :**

HYDRAULIC COMPACT EXCAVATOR:

Note: Vendor shall use Exhibit\_A Pricing Page(s) for bid pricing. If bidding online vendor should enter \$0.00 in the Oasis commodity line.

Vendor must attach the Exhibit\_A pricing page to their bid.

See Section 18 of Instructions to Bidders for additional information.

**SCHEDULE OF EVENTS**

Line	Event	Event Date
1	Mandatory Pre-Bid Meeting @ 10:00am EST	2017-06-15
2	Technical Questions due by:	2017-06-19

<b>DOT1700000086</b>	<b>Document Phase</b> Final	<b>Document Description</b> HYDRAULIC COMPACT TRACK EXCAVATOR	<b>Page 3</b> <b>of 3</b>
----------------------	--------------------------------	---	------------------------------

**ADDITIONAL TERMS AND CONDITIONS**

See attached document(s) for additional Terms and Conditions

**SOLICITATION NUMBER: CRFQ 0803 DOT1700000086**

**Addendum Number: 1**

---

The purpose of this addendum is to modify the solicitation identified as CRFQ 0803 DOT1700000086 ("Solicitation") to reflect the change(s) identified and described below.

**Applicable Addendum Category:**

- Modify bid opening date and time
- Modify Technical Question submission date
- Modify Mandatory Pre-Bid Meeting date
- Attachment of pre-bid sign-in sheet
- Correction of error
- Other

**Description of Modification to Solicitation:**

- 1: Move Pre-Bid Meeting date from June 15, 2017 to July 21, 2017 at 10:00am EST.**
- 2: Move Technical Question submittal deadline from June 19, 2017 to July 26, 2017.**
- 3: Move Bid Opening date from June 28, 2017 to August 08, 2017 @ 1:30pm EST.**

**NO OTHER CHANGES.**

**Additional Documentation:** Documentation related to this Addendum (if any) has been included herewith as Attachment A and is specifically incorporated herein by reference.

**Terms and Conditions:**

1. All provisions of the Solicitation and other addenda not modified herein shall remain in full force and effect.
2. Vendor should acknowledge receipt of all addenda issued for this Solicitation by completing an Addendum Acknowledgment, a copy of which is included herewith. Failure to acknowledge addenda may result in bid disqualification. The addendum acknowledgement should be submitted with the bid to expedite document processing.



**ADDENDUM ACKNOWLEDGEMENT FORM**  
**SOLICITATION NO.: CRFO 0803 DOT1700000086**

**Instructions:** Please acknowledge receipt of all addenda issued with this solicitation by completing this addendum acknowledgment form. Check the box next to each addendum received and sign below. Failure to acknowledge addenda may result in bid disqualification.

**Acknowledgment:** I hereby acknowledge receipt of the following addenda and have made the necessary revisions to my proposal, plans and/or specification, etc.

**Addendum Numbers Received:**

(Check the box next to each addendum received)

- |  |  |
|--|--|
| <input checked="" type="checkbox"/> Addendum No. 1 | <input type="checkbox"/> Addendum No. 6  |
| <input type="checkbox"/> Addendum No. 2            | <input type="checkbox"/> Addendum No. 7  |
| <input type="checkbox"/> Addendum No. 3            | <input type="checkbox"/> Addendum No. 8  |
| <input type="checkbox"/> Addendum No. 4            | <input type="checkbox"/> Addendum No. 9  |
| <input type="checkbox"/> Addendum No. 5            | <input type="checkbox"/> Addendum No. 10 |

I understand that failure to confirm the receipt of addenda may be cause for rejection of this bid. I further understand that that any verbal representation made or assumed to be made during any oral discussion held between Vendor's representatives and any state personnel is not binding. Only the information issued in writing and added to the specifications by an official addendum is binding.

Jefferds Corporation dba Bobcat of Advantage Valley  
Company

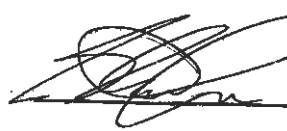
  
Authorized Signature

8-16-17

Date

**NOTE:** This addendum acknowledgment should be submitted with the bid to expedite document processing.



Purchasing Division  
 2019 Washington Street East  
 Post Office Box 50130  
 Charleston, WV 25305-0130

State of West Virginia  
 Request for Quotation  
 13 - Equipment

Proc Folder: 336215

Doc Description: ADDENDUM\_1: HYDRAULIC COMPACT TRACK EXCAVATOR

Proc Type: Central Master Agreement

Date Issued	Solicitation Closes	Solicitation No	Version
2017-06-12	2017-08-08 13:30:00	CRFQ 0803 DOT1700000086	2

**BID RECEIVING LOCATION**

BID CLERK  
 DEPARTMENT OF ADMINISTRATION  
 PURCHASING DIVISION  
 2019 WASHINGTON ST E  
 CHARLESTON WV 25305  
 US

**VENDOR**

 **Bobcat.**  
**Of Advantage Valley**  
 A Division of Jefferds Corporation  
 614 New Goff Mountain Road  
 Cross Lanes WV 25313

304-776-9100

**FOR INFORMATION CONTACT THE BUYER**

Mark A Atkins  
 (304) 558-2307  
 mark.a.atkins@wv.gov

Signature X 

FEIN # 55-0336065

DATE 8-16-17

All offers subject to all terms and conditions contained in this solicitation

**ADDITIONAL INFORMATION:**

**ADDENDUM 1:** Is issued for the following:

- 1: Move Pre-Bid Meeting date from June 15, 2017 to July 21, 2017 at 10:00am EST.
- 2: Move Technical Question submittal deadline from June 19, 2017 to July 26, 2017.
- 3: Move Bid Opening date from June 28, 2017 to August 08, 2017 @ 1:30pm EST.

**NO OTHER CHANGES.**

The West Virginia Purchasing Division is soliciting bids on behalf of the West Virginia Division of Highways (WVDOH), the West Virginia Department of Transportation (WVDOT), to establish an open-end contract for Hydraulic Compact Track Excavators per the attached documents.

**MANDATORY PRE-BID MEETING:**

A Mandatory Pre-Bid Meeting will be held on:

DATE: JULY 21, 2017

TIME: 10:00am EST

LOCATION: WVDOH

Equipment Division  
83 Brushy Fork Crossing  
Buckhannon, WV 26201

INVOICE TO	SHIP TO
DIVISION OF HIGHWAYS EQUIPMENT DIVISION RT 33 83 BRUSHY ROAD CROSSING, PO BOX 610 BUCKHANNON WV26201 US	DIVISION OF HIGHWAYS EQUIPMENT DIVISION 83 BRUSHY FORK RD CROSSING BUCKHANNON WV 26201 US

Line	Comm Ln Desc	Qty	Unit Issue	Unit Price	Total Price
1	Pricing shall be completed on Exhibit A Pricing Page.	0.00000	EA		

Comm Code	Manufacturer	Specification	Model #
22101526			

**Extended Description :**

**HYDRAULIC COMPACT EXCAVATOR:**

Note: Vendor shall use Exhibit\_A Pricing Page(s) for bid pricing. If bidding online vendor should enter \$0.00 in the Oasis commodity line.

Vendor must attach the Exhibit\_A pricing page to their bid.

See Section 18 of Instructions to Bidders for additional information.

**SCHEDULE OF EVENTS**

Line	Event	Event Date
1	Mandatory Pre-Bid Meeting @ 10:00am EST	2017-07-21
2	Technical Questions due by:	2017-07-26

<b>DOT1700000086</b>	<b>Document Phase</b> Final	<b>Document Description</b> ADDENDUM_1: HYDRAULIC COMPACT TRACK EXCAVATOR	<b>Page 3</b> <b>of 3</b>
----------------------	--------------------------------	---	------------------------------

**ADDITIONAL TERMS AND CONDITIONS**

See attached document(s) for additional Terms and Conditions

**SOLICITATION NUMBER: CRFQ 0803 DOT1700000086**

**Addendum Number: 1**

---

The purpose of this addendum is to modify the solicitation identified as CRFQ 0803 DOT1700000086 ("Solicitation") to reflect the change(s) identified and described below.

**Applicable Addendum Category:**

- Modify bid opening date and time
- Modify Technical Question submission date
- Modify Mandatory Pre-Bid Meeting date
- Attachment of pre-bid sign-in sheet
- Correction of error
- Other

**Description of Modification to Solicitation:**

- 1: Move Pre-Bid Meeting date from June 15, 2017 to July 21, 2017 at 10:00am EST.**
- 2: Move Technical Question submittal deadline from June 19, 2017 to July 26, 2017.**
- 3: Move Bid Opening date from June 28, 2017 to August 08, 2017 @ 1:30pm EST.**

**NO OTHER CHANGES.**

**Additional Documentation:** Documentation related to this Addendum (if any) has been included herewith as Attachment A and is specifically incorporated herein by reference.

**Terms and Conditions:**

1. All provisions of the Solicitation and other addenda not modified herein shall remain in full force and effect.
2. Vendor should acknowledge receipt of all addenda issued for this Solicitation by completing an Addendum Acknowledgment, a copy of which is included herewith. Failure to acknowledge addenda may result in bid disqualification. The addendum acknowledgement should be submitted with the bid to expedite document processing.

**ADDENDUM ACKNOWLEDGEMENT FORM**  
**SOLICITATION NO.: CRFO 0803 DOT170000086**

**Instructions:** Please acknowledge receipt of all addenda issued with this solicitation by completing this addendum acknowledgment form. Check the box next to each addendum received and sign below. Failure to acknowledge addenda may result in bid disqualification.

**Acknowledgment:** I hereby acknowledge receipt of the following addenda and have made the necessary revisions to my proposal, plans and/or specification, etc.

**Addendum Numbers Received:**

(Check the box next to each addendum received)

- |  |  |
|--|--|
| <input checked="" type="checkbox"/> Addendum No. 1 | <input type="checkbox"/> Addendum No. 6  |
| <input type="checkbox"/> Addendum No. 2            | <input type="checkbox"/> Addendum No. 7  |
| <input type="checkbox"/> Addendum No. 3            | <input type="checkbox"/> Addendum No. 8  |
| <input type="checkbox"/> Addendum No. 4            | <input type="checkbox"/> Addendum No. 9  |
| <input type="checkbox"/> Addendum No. 5            | <input type="checkbox"/> Addendum No. 10 |

I understand that failure to confirm the receipt of addenda may be cause for rejection of this bid. I further understand that that any verbal representation made or assumed to be made during any oral discussion held between Vendor's representatives and any state personnel is not binding. Only the information issued in writing and added to the specifications by an official addendum is binding.

Jefferds Corporation dba Bobcat of Advantage Valley

Company



Authorized Signature

8-16-17

Date

**NOTE:** This addendum acknowledgement should be submitted with the bid to expedite document processing.



Purchasing Division  
 2019 Washington Street East  
 Post Office Box 50130  
 Charleston, WV 25305-0130

State of West Virginia  
 Request for Quotation  
 13 - Equipment

Proc Folder: 336215

Doc Description: ADDENDUM\_2: HYDRAULIC COMPACT TRACK EXCAVATOR

Proc Type: Central Master Agreement

Date Issued	Solicitation Closes	Solicitation No	Version
2017-08-03	2017-08-08 13:30:00	CRFQ 0803 DOT1700000086	3

**BID RECEIVING LOCATION**

BID CLERK  
 DEPARTMENT OF ADMINISTRATION  
 PURCHASING DIVISION  
 2019 WASHINGTON ST E  
 CHARLESTON WV 25305  
 US

**VENDOR**

 **Bobcat.**  
**Of Advantage Valley**  
 A Division of Jefferds Corporation  
 614 New Goff Mountain Road  
 Cross Lanes WV 25313

304-776-9100

**FOR INFORMATION CONTACT THE BUYER**

Mark A Atkins  
 (304) 558-2307  
 mark.a.atkins@wv.gov

Signature X 

FEIN # 55-0336065

DATE 8-16-17

All offers subject to all terms and conditions contained in this solicitation

**ADDITIONAL INFORMATION**

**ADDENDUM 2:** Is issued for the following:

1. To publish the Agency responses to the questions submitted by Vendors during the Technical Questioning period.
2. To publish the pre-bid sign-in sheets.

NO OTHER CHANGES.

The West Virginia Purchasing Division is soliciting bids on behalf of the West Virginia Division of Highways (WVDOH), the West Virginia Department of Transportation (WVDOT), to establish an open-end contract for Hydraulic Compact Track Excavators per the attached documents.

INVOICE TO	BID TO
DIVISION OF HIGHWAYS EQUIPMENT DIVISION RT 33 83 BRUSHY ROAD CROSSING, PO BOX 610 BUCKHANNON WV26201 US	DIVISION OF HIGHWAYS EQUIPMENT DIVISION 83 BRUSHY FORK RD CROSSING BUCKHANNON WV 26201 US

Line	Comm Ln Desc	Qty	Unit Issue	Unit Price	Total Price
1	Pricing shall be completed on Exhibit A Pricing Page.	0.00000	EA		

Comm Code	Manufacturer	Specification	Model #
22101526			

Extended Description :

**HYDRAULIC COMPACT EXCAVATOR:**

Note: Vendor shall use Exhibit\_A Pricing Page(s) for bid pricing. If bidding online vendor should enter \$0.00 in the Oasis commodity line.

Vendor must attach the Exhibit\_A pricing page to their bid.

See Section 18 of Instructions to Bidders for additional information.

**SCHEDULE OF EVENTS**

Line	Event	Event Date
1	Mandatory Pre-Bid Meeting @ 10:00am EST	2017-07-21
2	Technical Questions due by:	2017-07-26



**SOLICITATION NUMBER: CRFQ 0803 DOT1700000086**

**Addendum Number: 2**

---

The purpose of this addendum is to modify the solicitation identified as CRFQ 0803 DOT1700000086 ("Solicitation") to reflect the change(s) identified and described below.

**Applicable Addendum Category:**

- Modify bid opening date and time
- Modify specifications of product or service being sought
- Attachment of vendor questions and responses
- Attachment of pre-bid sign-in sheet
- Correction of error
- Other

**Description of Modification to Solicitation:**

1. To publish the Agency responses to the questions submitted by Vendors during the Technical Questioning period.
2. To publish the pre-bid sign-in sheets.

No other changes made.

**Additional Documentation:** Documentation related to this Addendum (if any) has been included herewith as Attachment A and is specifically incorporated herein by reference.

**Terms and Conditions:**

1. All provisions of the Solicitation and other addenda not modified herein shall remain in full force and effect.
2. Vendor should acknowledge receipt of all addenda issued for this Solicitation by completing an Addendum Acknowledgment, a copy of which is included herewith. Failure to acknowledge addenda may result in bid disqualification. The addendum acknowledgement should be submitted with the bid to expedite document processing.

Attachment\_A

ADDENDUM\_2

CRFQ 0803 DOT1700000086

HYDRAULIC COMPACT TRACK EXCAVATOR

The original language in contract will be listed first with question and answer to follow below.

1. 3.1.2.2 – C Electric fuel priming pump

Question: Bobcat uses a manual fuel priming pump on its line of mini excavators. Electric priming pump is not available. Would a manual priming pump be acceptable?

Answer: yes, will change to read: Electric fuel priming pump or Manual priming pump.

2. 3.1.5.1 – A Rubber tracks minimum of 16 inches wide.

Question: Bobcat track measurement is 15.7 inches. Is that acceptable?

Answer: yes, Rubber tracks minimum of 15.7 inches wide.

3. 3.1.5.1 – B Track guides to prevent track misalignment.

Question: Could you clarify what you are looking for here? Bobcat does not offer any additional guides for track alignment. The track system is designed to prevent misalignment without the need for external accessories.

Answer: Will change to read: Track roller guides to prevent track misalignment.

4.. 3.1.5.1 - E Undercarriage with manufacturer's standard size hydraulic blade for model bid, with float.

Question: Our blade does not have a float, is this acceptable?

Answer: YES, Will change to read: Undercarriage with manufacturers standard size hydraulic blade for model bid with or without float.

5. 3.1.6.6 - D Shall have motion alarm with cancel switch

Question: The cat unit has a backup alarm, but it can't be cancelled during operation – could the cancel switch portion be removed?

Answer: yes, will change to read: Shall have travel/motion alarm.

6. 6.1.6.6 – H Rear secondary exit kit.

Question: Could you clarify what you are looking for here. Bobcat has access through left door, front window, and left window. Rear glass in Bobcat excavators is glued in.

Answer: will change to read: Excavator shall have more than one exit.

7. 6.1.6.6 – I Shall be wired for smart link capabilities.

Question # 1: Smart link is a proprietary system offered by John Deere. Bobcat does not offer this product at the moment. There may be some aftermarket GPS location products available but they would be limited in what information they would transmit.

Question # 2: Please explain Smart Link and what you want it to be able to provide?

Answer: Will change to read: Shall be wire ready for manufacturers Telematics if available by manufacturer bid. (were not asking for telemetric system, just factory wired ready for it thru manufacturer if manufactures model bid offers it)

8. 3.1.7.1 Unit bid shall have minimum digging depth of 12 foot and a minimum digging reach of 20 foot.

Question # 1: The Cat unit has a digging reach of 19.58 feet – could this be lowered?

Question # 2: Our digging depth is 11'7", and our minimum digging reach is 19'7", are these ok?

Question # 3: We have a digging reach of 19'11.4", is that acceptable?

Answer: Will change to read: Unit shall have Long arm with maximum dig depth and maximum reach for model bid.

9. This will be a combined question, Sections involved are:

3.1.4.8 Unit shall have auxiliary hydraulic lines with quick couplers and a 3-way hydraulic valve to switch from swivel head to thumb.

#### 3.1.9 Tilting Coupler/Swivel

**Question:** The way I interpret it, DOH is wanting the 3-way hydraulic valve to switch from swivel head to thumb so that the thumb doesn't have to be removed when operating the tilt function on the coupler. Cat offers a tilting coupler but it is not compatible with the thumb because of the way the thumb mounts – there are clearance issues that will inhibit the function of the tilt coupler. I am not sure if the other tilt coupler manufacturers (like HELAC) have the same issue. If the DOH is willing to relax the spec to allow removing the thumb when using the tilt coupler, they wouldn't need the 3-way valve.

**Answer:** Will change to read: Unit shall have auxiliary hydraulic lines with quick couplers and a 3-way hydraulic valve to switch from swivel head to thumb if needed.

**Answer:** No, we want to be able use swivel with thumb installed.

10. 3.1.9.4 Shall include integral quick coupler.

**Question:** There was some discussion about this in the meeting and I'm not completely sure what the discussion was with the other dealers. Bobcats hydra tilt swings 180 degrees. 90 left and 90 right. The hydra tilt itself has a integral quick disconnect that connects the hydra tilt to the excavator. The grading bucket that attaches to the hydra tilt has a 2 bolt disconnect that attaches the bucket to the hydra tilt. Is this what you are looking for here. I think this is fairly common throughout manufacturers.

**Answer:** yes, will accept.

11. 6.1 Delivery Time: Vendor shall deliver standard orders within 120 working days after orders are received. Vendor shall ship all orders in accordance with the above schedule and shall not hold orders until a minimum delivery quantity is met. A completed pilot model for inspection must be provided within 90 working day(s) after receipt of the purchase agreement by the successful vendor. Working day is defined as any week day, Monday thru Friday, excluding Federal and State Holidays.

**PRE-BID CONFERENCE  
SIGN IN SHEET**

Request for Quotation Number: CRFQ 0803 DOT 1700000086 Date: 7/21/17

Project Description: Hydraulic Compact Track Excavator

**PLEASE PRINT LEGIBLY. THIS INFORMATION IS ESSENTIAL TO CONTACT THE ATTENDEES IN A TIMELY MANNER. FAILURE TO DO SO MAY RESULT IN DELAYS IN YOUR COMPANY GETTING IMPORTANT BID INFORMATION.**

Firm Name:	Bobcat of Advantage Valley
Firm Address:	64 New Golf Mt Road Cross Lanes WV 25313
Representative Attending:	Steve Lewis
Phone Number:	304 776-9100
Fax Number:	304 776-0285
Email Address:	Steve.lewis@jeffcoals.com

Firm Name:	WEST VIRGINIA TRACUM
Firm Address:	P.O. BOX 473 CHARLESTON WV 25322
Representative Attending:	DAVE GRADY
Phone Number:	304-346-5301
Fax Number:	304-346-5305
Email Address:	westvirginiatracum@wvnsa.com

Firm Name:	Leslie Equipment Co
Firm Address:	19 Guff Crossing Dr Cross Lanes WV 25315
Representative Attending:	Eric Brooks
Phone Number:	304 204 1818
Fax Number:	304 204 1811
Email Address:	Brokeseric@Lech.com

Firm Name:	Rudd Equipment Co
Firm Address:	500 Ribey Road Nitro, WV 25840
Representative Attending:	Steve Neff
Phone Number:	304-541-3390
Fax Number:	304-755-7990
Email Address:	Sneff@RuddEquipment.com

Firm Name:	Walker Machinery
Firm Address:	P.O. Box 2427 Charleston, WV 25329
Representative Attending:	Matt Conner
Phone Number:	(304) 543-5406
Fax Number:	(304) 759-6404
Email Address:	mconner@walker-cs.com

Firm Name:	
Firm Address:	
Representative Attending:	
Phone Number:	
Fax Number:	
Email Address:	

PRE-BID CONFERENCE  
SIGN IN SHEET

Request for Quotation Number: CRFQ 0803 DOT 1700000086 Date: 7/21/17

Project Description: Hydraulic Compact Track Excavator

PLEASE PRINT LEGIBLY. THIS INFORMATION IS ESSENTIAL TO CONTACT THE ATTENDEES IN A TIMELY MANNER. FAILURE TO DO SO MAY RESULT IN DELAYS IN YOUR COMPANY GETTING IMPORTANT BID INFORMATION.

Firm Name: BRIDGEPORT EQUIPMENT AND TOOL  
Firm Address: 435 W. MYLES AVE  
PENNSBORO, NJ 26455  
Representative Attending: RON GARDNER  
Phone Number: 304-659-7917  
Fax Number: 304-659-3276  
Email Address: R.GARDNER@BRIDGEPORTEQUIPMENT.COM

Firm Name: \_\_\_\_\_  
Firm Address: \_\_\_\_\_  
Representative Attending: \_\_\_\_\_  
Phone Number: \_\_\_\_\_  
Fax Number: \_\_\_\_\_  
Email Address: \_\_\_\_\_

Firm Name: Bridgeport Equipment and Tool  
Firm Address: 15 Acers Street  
Marietta, OH 45750  
Representative Attending: Chris Walter  
Phone Number: 740-373-6686  
Fax Number: 740-373-3895  
Email Address: Cwalter@bridgeport-equip.com

Firm Name: \_\_\_\_\_  
Firm Address: \_\_\_\_\_  
Representative Attending: \_\_\_\_\_  
Phone Number: \_\_\_\_\_  
Fax Number: \_\_\_\_\_  
Email Address: \_\_\_\_\_

Firm Name: Bridgeport Equipment & Tool  
Firm Address: 6777 Morris Creek Rd  
Huntman WV 25702  
Representative Attending: Brandon Newille  
Phone Number: 304-736-2120  
Fax Number: 304-736-2120  
Email Address: bnwille@bridgeport-equip.com

Firm Name: \_\_\_\_\_  
Firm Address: \_\_\_\_\_  
Representative Attending: \_\_\_\_\_  
Phone Number: \_\_\_\_\_  
Fax Number: \_\_\_\_\_  
Email Address: \_\_\_\_\_

PRE-BID CONFERENCE  
SIGN IN SHEET

Request for Quotation Number: CRFQ 0803 DOT 1700000086 Date: 7/21/17

Project Description: Hydraulic Compact Track Excavator

PLEASE PRINT LEGIBLY. THIS INFORMATION IS ESSENTIAL TO CONTACT THE ATTENDEES IN A TIMELY MANNER. FAILURE TO DO SO  
MAY RESULT IN DELAYS IN YOUR COMPANY GETTING IMPORTANT BID INFORMATION.

Firm Name:	Anderson Equipment Co.
Firm Address:	<del>2007 Ruskin Drive</del> 1 Andy's Way S. Charleston W.V.
Representative Attending:	Bert R. Smith
Phone Number:	304-614-5811
Fax Number:	
Email Address:	bsmith@andersonequip.com

Firm Name:	
Firm Address:	
Representative Attending:	
Phone Number:	
Fax Number:	
Email Address:	

Firm Name:	State Equipment, LLC
Firm Address:	560 New Goff Mtn. Rd. Cross Lanes, W.V.
Representative Attending:	Tom Conner
Phone Number:	304 776 4405
Fax Number:	304 776 4409
Email Address:	eddie@stateequipment.com

Firm Name:	
Firm Address:	
Representative Attending:	
Phone Number:	
Fax Number:	
Email Address:	

Firm Name:	
Firm Address:	
Representative Attending:	
Phone Number:	
Fax Number:	
Email Address:	

Firm Name:	
Firm Address:	
Representative Attending:	
Phone Number:	
Fax Number:	
Email Address:	

PRE-BID CONFERENCE  
SIGN IN SHEET

Request for Quotation Number: CRFQ 0803 DOT 1700000086 Date: 7/2/17

Project Description: Hydraulic Compact Track Excavator

**PLEASE PRINT LEGIBLY. THIS INFORMATION IS ESSENTIAL TO CONTACT THE ATTENDEES IN A TIMELY MANNER. FAILURE TO DO SO MAY RESULT IN DELAYS IN YOUR COMPANY GETTING IMPORTANT BID INFORMATION.**

Firm Name:	
Firm Address:	<u>Prm Hall</u>
	<u>WVDOH</u>
Representative Attending:	
Phone Number:	
Fax Number:	
Email Address:	

Firm Name:	<u>Todd Campbell</u>
Firm Address:	<u>WVDOH</u>
Representative Attending:	
Phone Number:	
Fax Number:	
Email Address:	

Firm Name:	
Firm Address:	<u>Angie Morgan</u>
	<u>DOH</u>
Representative Attending:	
Phone Number:	
Fax Number:	
Email Address:	

Firm Name:	
Firm Address:	<u>MARCIN LEE</u>
	<u>DOH</u>
Representative Attending:	
Phone Number:	
Fax Number:	
Email Address:	

Firm Name:	
Firm Address:	<u>Harley Smith</u>
	<u>WV DOH</u>
Representative Attending:	
Phone Number:	
Fax Number:	
Email Address:	

Firm Name:	
Firm Address:	
Representative Attending:	
Phone Number:	
Fax Number:	
Email Address:	



OFFICE (304) 346-5301  
(800) 640-8245



# WEST VIRGINIA TRACTOR COMPANY

CONSTRUCTION, MINING, MUNICIPAL & INDUSTRIAL EQUIPMENT

www.wvtractor.com

**GARY W. GRADY**  
PRESIDENT  
Res. (304) 346-9372  
Cell (304) 549-6056

P. O. BOX 473,  
214 VIRGINIA ST. W.  
CHAS., WV 25322/25302

wvtractor@msn.com

**STEVE NEFF**  
PRODUCT SUPPORT REPRESENTATIVE



(304) 755-7788 Office  
(304) 541-3390 Cell  
sneff@ruddequipment.com



Ph: 740-373-6686  
Fax: 740-373-3895  
Cell: 740-338-9295

15 Acme Street  
Marietta, OH 45750

**BRANDON NEVILLE**  
Sales Manager

bneville@bridgeportequip.com



Now in 7 Locations in West Virginia, Ohio, and Kentucky!

www.bridgeportequip.com



"Run with the Best"

**Eric Brookes**

Sales Representative

19 Goff Crossing Drive  
Cross Lanes, WV 25313  
brookeseric@lec1.com  
www.lec1.com



JOHN DEERE

Office: 304-204-1818  
Fax: 304-204-1811  
Cell: 304-542-0433



Ph: 304-659-2917  
Fax: 304-659-3276  
Cell: 304-997-6354

435 W. Myles Avenue  
Pennsboro, WV 26415

**RON GARDNER**  
Sales

rgardner@bridgeportequip.com



Now in 9 Locations in West Virginia, Ohio, and Kentucky!

www.bridgeportequip.com



Toronto Store 740-537-5300  
Bridgeport Store 740-635-1129  
New Martinsville 304-455-6686

**CHRIS WALTER**  
General Manager

Ph: 304-455-6686  
Fax: 304-455-6685  
1200 S. Bridge Street  
New Martinsville, WV 26155  
Toll Free: 1-866-95-DEERE

Ph: 740-373-6686  
Fax: 740-373-3895  
15 Acme Street  
Marietta, OH 45750

cwalter@bridgeportequipmentandtool.com

## STATE EQUIPMENT, INC.



**TOM CONNER**  
MANAGER

CELL: 304-869-0442  
OFFICE: 304-592-0491  
HOME: 304-903-8075  
FAX: 304-592-0499  
EMAIL: TCONNER@STATEEQUIPMENT.COM  
WWW.STATEEQUIPMENT.COM

RR2 Box 849F  
SHINNSTON, WV 26431



## Bobcat of Advantage Valley

614 New Goff Mt. Road • Cross Lanes, WV 25313  
(304) 776-9100 • Fax (304) 776-0285  
1 866-4BOBCAT • Cell (304) 561-8280  
Email: stevelewis@jefferds.com  
Web: www.Bobcatwv.com

**Steve Lewis**  
Bobcat Specialist



## Anderson EQUIPMENT COMPANY

Your COMPLETE Equipment Solution

**Bert Smith**  
Sales Representative

Fairmont Branch  
2007 Ruskin Drive  
Pleasant Valley, WV 26554  
bert@andersonsequip.com  
Phone: 304-366-3075  
Fax: 304-366-7214  
Mobile: 304-614-5811

West Virginia  
Salesman of the Year 2015

www.andersonsequip.com

# Walker



**Matt Conner**  
Sales Representative

**Cecil I. Walker Machinery Co.**  
P.O. Box 2427  
Charleston, WV 25329-2427  
304.949.6400  
304.759.6404 fax  
304.543.5406 cell  
mconner@walker-cat.com  
walker-cat.com

**ADDENDUM ACKNOWLEDGEMENT FORM**  
**SOLICITATION NO.: CRFQ 0803 DOT1700000086**

**Instructions:** Please acknowledge receipt of all addenda issued with this solicitation by completing this addendum acknowledgment form. Check the box next to each addendum received and sign below. Failure to acknowledge addenda may result in bid disqualification.

**Acknowledgment:** I hereby acknowledge receipt of the following addenda and have made the necessary revisions to my proposal, plans and/or specification, etc.

**Addendum Numbers Received:**

(Check the box next to each addendum received)

- |  |  |
|--|--|
| <input checked="" type="checkbox"/> Addendum No. 1 | <input type="checkbox"/> Addendum No. 6  |
| <input checked="" type="checkbox"/> Addendum No. 2 | <input type="checkbox"/> Addendum No. 7  |
| <input type="checkbox"/> Addendum No. 3            | <input type="checkbox"/> Addendum No. 8  |
| <input type="checkbox"/> Addendum No. 4            | <input type="checkbox"/> Addendum No. 9  |
| <input type="checkbox"/> Addendum No. 5            | <input type="checkbox"/> Addendum No. 10 |

I understand that failure to confirm the receipt of addenda may be cause for rejection of this bid. I further understand that that any verbal representation made or assumed to be made during any oral discussion held between Vendor's representatives and any state personnel is not binding. Only the information issued in writing and added to the specifications by an official addendum is binding.

Jefferds Corporation dba Bobcat of Advantage Valley

Company



Authorized Signature

8-16-17

Date

**NOTE:** This addendum acknowledgement should be submitted with the bid to expedite document processing.



Purchasing Division  
 2019 Washington Street East  
 Post Office Box 50130  
 Charleston, WV 25305-0130

State of West Virginia  
 Request for Quotation  
 13 – Equipment

Proc Folder: 336215

Doc Description: ADDENDUM\_2: HYDRAULIC COMPACT TRACK EXCAVATOR

Proc Type: Central Master Agreement

Date Issued	Solicitation Closes	Solicitation No	Version
2017-08-03	2017-08-08 13:30:00	CRFQ 0803 DOT1700000086	3

**ADDRESS**

BID CLERK  
 DEPARTMENT OF ADMINISTRATION  
 PURCHASING DIVISION  
 2019 WASHINGTON ST E  
 CHARLESTON WV 25305  
 US

**CONTACT**

 **Bobcat**  
 Of Advantage Valley  
 A Division of Jefferds Corporation  
 614 New Goff Mountain Road  
 Cross Lanes WV 25313

304-776-9100

**FOR INFORMATION CONTACT THE BUYER**

Mark A Atkins  
 (304) 558-2307  
 mark.a.atkins@wv.gov

Signature X 

FEIN # 55-0336065

DATE 8-16-17

All offers subject to all terms and conditions contained in this solicitation

ADDE IDUM\_2: Is issued for the following:

1. To publish the Agency responses to the questions submitted by Vendors during the Technical Questioning period.
2. To publish the pre-bid sign-in sheets.

NO OTHER CHANGES.

The West Virginia Purchasing Division is soliciting bids on behalf of the West Virginia Division of Highways (WVDOH), the West Virginia Department of Transportation (WVDOT), to establish an open-end contract for Hydraulic Compact Track Excavators per the attached documents.

DIVISION OF HIGHWAYS EQUIPMENT DIVISION RT 33 83 BRUSHY ROAD CROSSING, PO BOX 610 BUCKHANNON WV26201 US	DIVISION OF HIGHWAYS EQUIPMENT DIVISION 83 BRUSHY FORK RD CROSSING BUCKHANNON WV 26201 US
---	---

Line	Comm Ln Desc	Qty	Unit Issue	Unit Price	Total Price
1	Pricing shall be completed on Exhibit A Pricing Page.	0.00000	EA		

Comm Code	Manufacturer	Specification	Model #
22101526			

**Extended Description :**

HYDRAULIC COMPACT EXCAVATOR:

Note: Vendor shall use Exhibit\_A Pricing Page(s) for bid pricing. If bidding online vendor should enter \$0.00 in the Oasis commodity line.

Vendor must attach the Exhibit\_A pricing page to their bid.

See Section 18 of Instructions to Bidders for additional information.

Line	Event	Event Date
1	Mandatory Pre-Bid Meeting @ 10:00am EST	2017-07-21
2	Technical Questions due by:	2017-07-26

<b>DOT1700000086</b>	<b>Document Phase</b> Final	<b>Document Description</b> ADDENDUM_2: HYDRAULIC COMPACT TRACK EXCAVATOR	<b>Page 3</b> <b>of 3</b>
----------------------	--------------------------------	---	------------------------------

**ADDITIONAL TERMS AND CONDITIONS**

See attached document(s) for additional Terms and Conditions



Purchasing Division  
 2019 Washington Street East  
 Post Office Box 50130  
 Charleston, WV 25305-0130

State of West Virginia  
 Request for Quotation  
 13 – Equipment

Proc Folder: 336215

Doc Description: ADDENDUM\_3: HYDRAULIC COMPACT TRACK EXCAVATOR

Proc Type: Central Master Agreement

Date Issued	Solicitation Closes	Solicitation No	Version
2017-08-04	2017-08-16 13:30:00	CRFQ 0803 DOT1700000086	4

**BID RECEIVING LOCATION**

BID CLERK  
 DEPARTMENT OF ADMINISTRATION  
 PURCHASING DIVISION  
 2019 WASHINGTON ST E  
 CHARLESTON WV 25305  
 US

**VENDOR**

 **Bobcat.**  
**Of Advantage Valley**  
 A Division of Jefferds Corporation  
 614 New Goff Mountain Road  
 Cross Lanes WV 25313

304-776-9100

**FOR INFORMATION CONTACT THE BUYER**

Mark A Atkins  
 (304) 558-2307  
 mark.a.atkins@wv.gov

Signature X 

FEIN # 55-0336065

DATE 8-16-17

All offers subject to all terms and conditions contained in this solicitation

**ADDITIONAL INFORMATION:**

ADDENDUM 3: Is issued for the following:

1. Move Bid Opening date from August 08, 2017 to August 16, 2017 @ 1:30pm EST.

NO OTHER CHANGES.

The West Virginia Purchasing Division is soliciting bids on behalf of the West Virginia Division of Highways (WVDOH), the West Virginia Department of Transportation (WVDOT), to establish an open-end contract for Hydraulic Compact Track Excavators per the attached documents.

INVOICE TO	SHIP TO
DIVISION OF HIGHWAYS EQUIPMENT DIVISION RT 33 83 BRUSHY ROAD CROSSING, PO BOX 610 BUCKHANNON WV26201 US	DIVISION OF HIGHWAYS EQUIPMENT DIVISION 83 BRUSHY FORK RD CROSSING BUCKHANNON WV 26201 US

Line	Comm Ln Desc	Qty	Unit Issue	Unit Price	Total Price
1	Pricing shall be completed on Exhibit A Pricing Page.	0.00000	EA		

Comm Code	Manufacturer	Specification	Model #
22101526			

Extended Description :

HYDRAULIC COMPACT EXCAVATOR:

Note: Vendor shall use Exhibit\_A Pricing Page(s) for bid pricing. If bidding online vendor should enter \$0.00 in the Oasis commodity line.

Vendor must attach the Exhibit\_A pricing page to their bid.

See Section 18 of Instructions to Bidders for additional information.

**SCHEDULE OF EVENTS:**

Line	Event	Event Date
1	Mandatory Pre-Bid Meeting @ 10:00am EST	2017-07-21
2	Technical Questions due by:	2017-07-26

# SOLICITATION NUMBER: CRFQ 0803 DOT1700000086

## Addendum Number: 3

---

The purpose of this addendum is to modify the solicitation identified as CRFQ 0803 DOT1700000086 ("Solicitation") to reflect the change(s) identified and described below.

### Applicable Addendum Category:

- Modify bid opening date and time
- Modify Technical Question submission date
- Modify Mandatory Pre-Bid Meeting date
- Attachment of pre-bid sign-in sheet
- Correction of error
- Other

### Description of Modification to Solicitation:

1: Move Bid Opening date from August 08, 2017 to August 16, 2017 @ 1:30pm EST.

NO OTHER CHANGES.

**Additional Documentation:** Documentation related to this Addendum (if any) has been included herewith as Attachment A and is specifically incorporated herein by reference.

### Terms and Conditions:

1. All provisions of the Solicitation and other addenda not modified herein shall remain in full force and effect.
2. Vendor should acknowledge receipt of all addenda issued for this Solicitation by completing an Addendum Acknowledgment, a copy of which is included herewith. Failure to acknowledge addenda may result in bid disqualification. The addendum acknowledgement should be submitted with the bid to expedite document processing.



**ADDENDUM ACKNOWLEDGEMENT FORM**  
**SOLICITATION NO.: CRFO 0803 DOT1700000086**

**Instructions:** Please acknowledge receipt of all addenda issued with this solicitation by completing this addendum acknowledgment form. Check the box next to each addendum received and sign below. Failure to acknowledge addenda may result in bid disqualification.

**Acknowledgment:** I hereby acknowledge receipt of the following addenda and have made the necessary revisions to my proposal, plans and/or specification, etc.

**Addendum Numbers Received:**

(Check the box next to each addendum received)

- |  |  |
|--|--|
| <input checked="" type="checkbox"/> Addendum No. 1 | <input type="checkbox"/> Addendum No. 6  |
| <input checked="" type="checkbox"/> Addendum No. 2 | <input type="checkbox"/> Addendum No. 7  |
| <input checked="" type="checkbox"/> Addendum No. 3 | <input type="checkbox"/> Addendum No. 8  |
| <input type="checkbox"/> Addendum No. 4            | <input type="checkbox"/> Addendum No. 9  |
| <input type="checkbox"/> Addendum No. 5            | <input type="checkbox"/> Addendum No. 10 |

I understand that failure to confirm the receipt of addenda may be cause for rejection of this bid. I further understand that that any verbal representation made or assumed to be made during any oral discussion held between Vendor's representatives and any state personnel is not binding. Only the information issued in writing and added to the specifications by an official addendum is binding.

\_\_\_\_\_  
Jefferds Corporation dba Bobcat of Advantage Valley

\_\_\_\_\_  
Company

  
\_\_\_\_\_  
Authorized Signature

8-16-17  
\_\_\_\_\_  
Date

\_\_\_\_\_  
Date

**NOTE:** This addendum acknowledgement should be submitted with the bid to expedite document processing.



Purchasing Division  
 2019 Washington Street East  
 Post Office Box 50130  
 Charleston, WV 25305-0130

State of West Virginia  
 Request for Quotation  
 13 – Equipment

Proc Folder: 336215

Doc Description: ADDENDUM\_3: HYDRAULIC COMPACT TRACK EXCAVATOR

Proc Type: Central Master Agreement

Date Issued	Solicitation Closes	Solicitation No	Version
2017-08-04	2017-08-16 13:30:00	CRFQ 0803 DOT1700000086	4

BID CLERK  
 DEPARTMENT OF ADMINISTRATION  
 PURCHASING DIVISION  
 2019 WASHINGTON ST E  
 CHARLESTON WV 25305  
 US

 **Bobcat**  
 Of Advantage Valley  
 A Division of Jefferds Corporation  
 614 New Goff Mountain Road  
 Cross Lanes WV 25313

304-776-9100

FOR INFORMATION CONTACT THE BUYER

Mark A Atkins  
 (304) 558-2307  
 mark.a.atkins@wv.gov

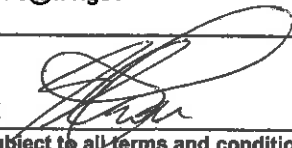
Signature X 

FEIN # 55-0336065

DATE 8-16-17

All offers subject to all terms and conditions contained in this solicitation

ADDENDUM 3: Is issued for the following:

1. Move Bid Opening date from August 08, 2017 to August 16, 2017 @ 1:30pm EST.

NO OTHER CHANGES.

The West Virginia Purchasing Division is soliciting bids on behalf of the West Virginia Division of Highways (WVDOH), the West Virginia Department of Transportation (WVDOT), to establish an open-end contract for Hydraulic Compact Track Excavators per the attached documents.

DIVISION OF HIGHWAYS EQUIPMENT DIVISION RT 33 83 BRUSHY ROAD CROSSING, PO BOX 610 BUCKHANNON WV26201 US	DIVISION OF HIGHWAYS EQUIPMENT DIVISION 83 BRUSHY FORK RD CROSSING BUCKHANNON WV 26201 US
---	---

Line	Comm Ln Desc	Qty	Unit Issue	Unit Price	Total Price
1	Pricing shall be completed on Exhibit A Pricing Page.	0.00000	EA		

Comm Code	Manufacturer	Specification	Model #
22101526			

**Extended Description :**

HYDRAULIC COMPACT EXCAVATOR:

Note: Vendor shall use Exhibit\_A Pricing Page(s) for bid pricing. If bidding online vendor should enter \$0.00 in the Oasis commodity line.

Vendor must attach the Exhibit\_A pricing page to their bid.

See Section 18 of Instructions to Bidders for additional information.

Line	Event	Event Date
1	Mandatory Pre-Bid Meeting @ 10:00am EST	2017-07-21
2	Technical Questions due by:	2017-07-26

<b>DOT1700000086</b>	<b>Document Phase</b> Final	<b>Document Description</b> ADDENDUM_3: HYDRAULIC COMPACT TRACK EXCAVATOR	<b>Page 3</b> <b>of 3</b>
----------------------	--------------------------------	---	------------------------------

**ADDITIONAL TERMS AND CONDITIONS**

See attached document(s) for additional Terms and Conditions



Purchasing Division  
 2019 Washington Street East  
 Post Office Box 50130  
 Charleston, WV 25305-0130

State of West Virginia  
 Request for Quotation  
 13 – Equipment

Proc Folder: 336215

Doc Description: ADDENDUM\_4: HYDRAULIC COMPACT TRACK EXCAVATOR

Proc Type: Central Master Agreement

Date issued	Solicitation Closes	Solicitation No	Version
2017-08-11	2017-08-16 13:30:00	CRFQ 0803 DOT1700000086	5

**BID RECEIVING LOCATION**

BID CLERK  
 DEPARTMENT OF ADMINISTRATION  
 PURCHASING DIVISION  
 2019 WASHINGTON ST E  
 CHARLESTON WV 25305  
 US

**VENDOR**

 **Bobcat**  
 Of Advantage Valley  
 A Division of Jefferds Corporation  
 614 New Goff Mountain Road  
 Cross Lanes WV 25313

304-776-9100

**FOR INFORMATION CONTACT THE BUYER**

Mark A Atkins  
 (304) 558-2307  
 mark.a.atkins@wv.gov

Signature X

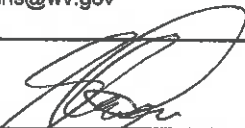

FEIN #

55-0336065

DATE

8-16-17

All offers subject to all terms and conditions contained in this solicitation

**ADDITIONAL INFORMATION:**

ADDENDUM 4: Is issued for the following:

1: To publish additional clarification to the agency response to technical questions posed by vendors concerning specification requirements for Specification 3.1.9.4. during the Technical Questioning Period and to attach Exhibit C for reference.

NO OTHER CHANGES.

The West Virginia Purchasing Division is soliciting bids on behalf of the West Virginia Division of Highways (WVDOH), the West Virginia Department of Transportation (WVDOT), to establish an open-end contract for Hydraulic Compact Track Excavators per the attached documents.

INVOICE TO	SHIP TO
DIVISION OF HIGHWAYS EQUIPMENT DIVISION RT 33 83 BRUSHY ROAD CROSSING, PO BOX 610 BUCKHANNON WV26201 US	DIVISION OF HIGHWAYS EQUIPMENT DIVISION 83 BRUSHY FORK RD CROSSING BUCKHANNON WV 26201 US

Line	Comm Ln Desc	Qty	Unit Issue	Unit Price	Total Price
1	Pricing shall be completed on Exhibit A Pricing Page.	0.00000	EA		

Comm Code	Manufacturer	Specification	Model #
22101526			

Extended Description :

HYDRAULIC COMPACT EXCAVATOR:

Note: Vendor shall use Exhibit\_A Pricing Page(s) for bid pricing. If bidding online vendor should enter \$0.00 in the Oasis commodity line.

Vendor must attach the Exhibit\_A pricing page to their bid.

See Section 18 of Instructions to Bidders for additional information.

**SCHEDULE OF EVENTS**

Line	Event	Event Date
1	Mandatory Pre-Bid Meeting @ 10:00am EST	2017-07-21
2	Technical Questions due by:	2017-07-26

# SOLICITATION NUMBER: CRFQ 0803 DOT1700000086

## Addendum Number: 4

---

The purpose of this addendum is to modify the solicitation identified as CRFQ 0803 DOT1700000086 ("Solicitation") to reflect the change(s) identified and described below.

### Applicable Addendum Category:

- Modify bid opening date and time
- Modify Technical Question submission date
- Modify Mandatory Pre-Bid Meeting date
- Attachment of pre-bid sign-in sheet
- Publish Exhibit\_C for reference.
- Clarification to the agency response to technical questions concerning Specification 3.1.9.4.

### Description of Modification to Solicitation:

**1: To publish additional clarification to the agency response to technical questions posed by vendors concerning specification requirements for Specification 3.1.9.4. and attach Exhibit C for reference.**

**NO OTHER CHANGES.**

**Additional Documentation:** Documentation related to this Addendum (if any) has been included herewith as Attachment A and is specifically incorporated herein by reference.

### Terms and Conditions:

1. All provisions of the Solicitation and other addenda not modified herein shall remain in full force and effect.
2. Vendor should acknowledge receipt of all addenda issued for this Solicitation by completing an Addendum Acknowledgment, a copy of which is included herewith. Failure to acknowledge addenda may result in bid disqualification. The addendum acknowledgement should be submitted with the bid to expedite document processing.

Attachment\_A

Addendum\_4



CRFQ 0803 DOT170000086

**HYDRAULIC COMPACT TRACK EXCAVATOR**

The original language in contract will be listed first with question and answer to follow below.

**1. 3.1.9.4 Shall include integral quick coupler.**

**Question # 1:** I see that # 10 on the addendum is addressing 3.1.9.4. It states that Bobcat is allowed to use its quick disconnect system. We discussed at the pre bid about this being a Pin Grabber Coupler, to me this is contradicting what we talked about at the pre bid. Any chance we could get clarification on this? Huge price difference between pin grabber style, and the quick disconnect style.

**Question # 2:** In the prebid meeting, the question was asked, relating to item 3.1.9.4, if the agency was wanting a hydraulic pin grabber style coupler. They answered yes, that is what they were looking for. On addendum # 2, question 10 was raised by Bobcat asking if their coupler with a 2 bolt disconnect would be acceptable and it was answered that it would – that is a manual style coupler and not a hydraulic pin grabber. There is a significant cost difference between the manual style and the hydraulic pin grabber style. Can you please provide clarification so we are sure we are providing the correct coupler?

**Answer:** Will Change the following to read: 3.1.9.4 Shall have standard pin on half- hitch coupler or Equal.

**3.1.10.1 Unit shall include a 40-inch minimum smooth ditching bucket with pins.**

**3.1.10.2 Unit shall include a 24-inch digging bucket with pins and replaceable teeth.**

**3.1.9.3 Shall allow use of OEM bucket (Will be Removed)**

**3.1.10.3 Both Buckets ditching and digging shall work with half- hitch coupler.**

**2. The WVDOH will also be adding an Exhibit C to this contract. Please see attached Exhibit C.**



# EXHIBIT C

**A.** Standard Half-Hitch Pin on Swivel Coupler

**B.** 40-inch Smooth Ditching Bucket

**C.** 24-inch Digging Bucket w/replaceable teeth

**A.**



Standard pin-on

**B.**

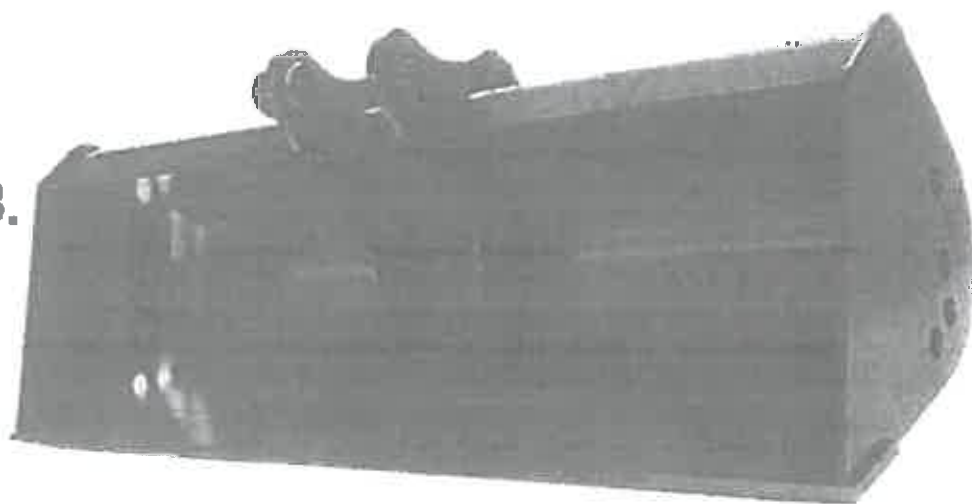

**C.**

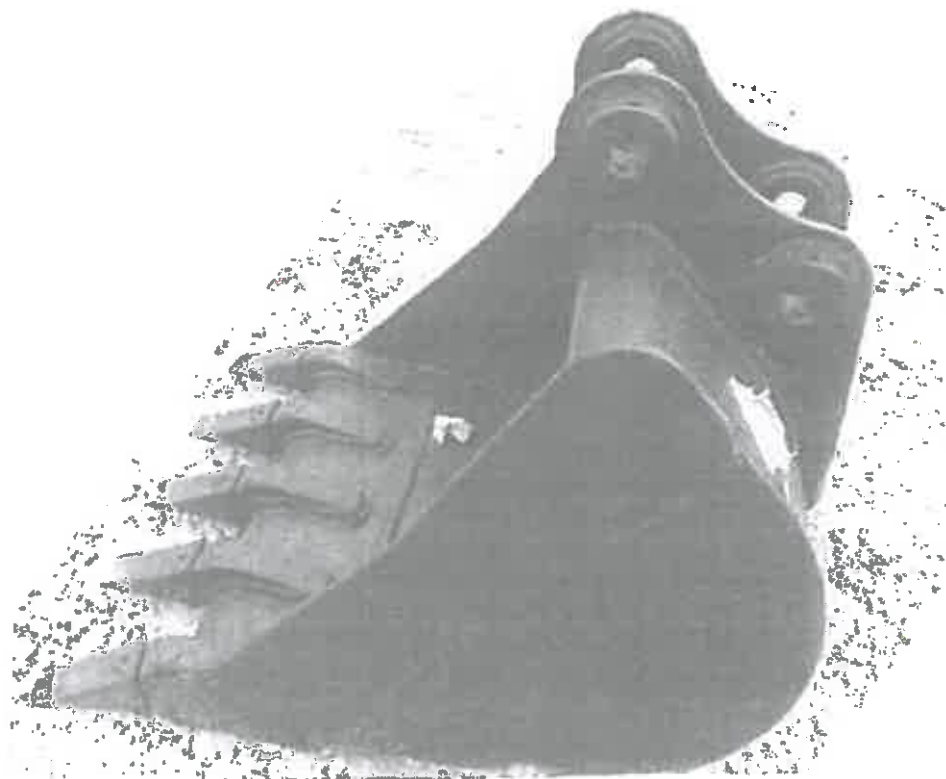

**ADDENDUM ACKNOWLEDGEMENT FORM**  
**SOLICITATION NO.: CRFO 0803 DOT1700000086**

**Instructions:** Please acknowledge receipt of all addenda issued with this solicitation by completing this addendum acknowledgment form. Check the box next to each addendum received and sign below. Failure to acknowledge addenda may result in bid disqualification.

**Acknowledgment:** I hereby acknowledge receipt of the following addenda and have made the necessary revisions to my proposal, plans and/or specification, etc.

**Addendum Numbers Received:**

(Check the box next to each addendum received)

- |  |  |
|--|--|
| <input checked="" type="checkbox"/> Addendum No. 1 | <input type="checkbox"/> Addendum No. 6  |
| <input checked="" type="checkbox"/> Addendum No. 2 | <input type="checkbox"/> Addendum No. 7  |
| <input checked="" type="checkbox"/> Addendum No. 3 | <input type="checkbox"/> Addendum No. 8  |
| <input checked="" type="checkbox"/> Addendum No. 4 | <input type="checkbox"/> Addendum No. 9  |
| <input type="checkbox"/> Addendum No. 5            | <input type="checkbox"/> Addendum No. 10 |

I understand that failure to confirm the receipt of addenda may be cause for rejection of this bid. I further understand that that any verbal representation made or assumed to be made during any oral discussion held between Vendor's representatives and any state personnel is not binding. Only the information issued in writing and added to the specifications by an official addendum is binding.

Jefferds Corporation dba Bobcat of Advantage Valley

Company



Authorized Signature

8-16-17

Date

**NOTE:** This addendum acknowledgement should be submitted with the bid to expedite document processing.



Purchasing Division  
 2019 Washington Street East  
 Post Office Box 50130  
 Charleston, WV 25305-0130

State of West Virginia  
 Request for Quotation  
 13 - Equipment

Proc Folder: 336215

Doc Description: ADDENDUM\_4: HYDRAULIC COMPACT TRACK EXCAVATOR

Proc Type: Central Master Agreement

Date Issued	Solicitation Closes	Solicitation No	Version
2017-08-11	2017-08-16 13:30:00	CRFQ 0803 DOT1700000086	5

BID CLERK  
 DEPARTMENT OF ADMINISTRATION  
 PURCHASING DIVISION  
 2019 WASHINGTON ST E  
 CHARLESTON WV 25305  
 US

 **Bobcat**  
 Of Advantage Valley  
 A Division of Jefferds Corporation  
 614 New Goff Mountain Road  
 Cross Lanes WV 25313

304-776-9100

FOR INFORMATION CONTACT THE BUYER

Mark A Atkins  
 (304) 558-2307  
 mark.a.atkins@wv.gov

Signature X 

FEIN # 55-0336065

DATE 8-16-17

All offers subject to all terms and conditions contained in this solicitation

**ADDENDUM\_4: Is issued for the following:**

1: To publish additional clarification to the agency response to technical questions posed by vendors concerning specification requirements for Specification 3.1.9.4. during the Technical Questioning Period and to attach Exhibit C for reference.

**NO OTHER CHANGES.**

The West Virginia Purchasing Division is soliciting bids on behalf of the West Virginia Division of Highways (WVDOH), the West Virginia Department of Transportation (WVDOT), to establish an open-end contract for Hydraulic Compact Track Excavators per the attached documents.

DIVISION OF HIGHWAYS EQUIPMENT DIVISION RT 33 83 BRUSHY ROAD CROSSING, PO BOX 610 BUCKHANNON WV26201 US	DIVISION OF HIGHWAYS EQUIPMENT DIVISION 83 BRUSHY FORK RD CROSSING BUCKHANNON WV 26201 US
---	---

Line	Comm Ln Desc	Qty	Unit Issue	Unit Price	Total Price
1	Pricing shall be completed on Exhibit A Pricing Page.	0.00000	EA		

Comm Code	Manufacturer	Specification	Model #
22101526	Bobcat	E50	E50

**Extended Description :**

HYDRAULIC COMPACT EXCAVATOR:

Note: Vendor shall use Exhibit\_A Pricing Page(s) for bid pricing. If bidding online vendor should enter \$0.00 in the Oasis commodity line.

Vendor must attach the Exhibit\_A pricing page to their bid.

See Section 18 of Instructions to Bidders for additional information.



Line	Event	Event Date
1	Mandatory Pre-Bid Meeting @ 10:00am EST	2017-07-21
2	Technical Questions due by:	2017-07-26

<b>DOT1700000086</b>	<b>Document Phase</b> <i>Final</i>	<b>Document Description</b> ADDENDUM_4: HYDRAULIC COMPACT TRACK EXCAVATOR	<b>Page 3</b> <b>of 3</b>
----------------------	---------------------------------------	---	------------------------------

**ADDITIONAL TERMS AND CONDITIONS**

See attached document(s) for additional Terms and Conditions

# EXCAVATOR SPECIFICATIONS

## E50 Excavator Machine Dimensions

- All dimensions are shown in inches. Respective metric dimensions are given in millimeters enclosed by parentheses.
  - Where applicable, specifications conform to SAE or ISO standards and are subject to change without notice.

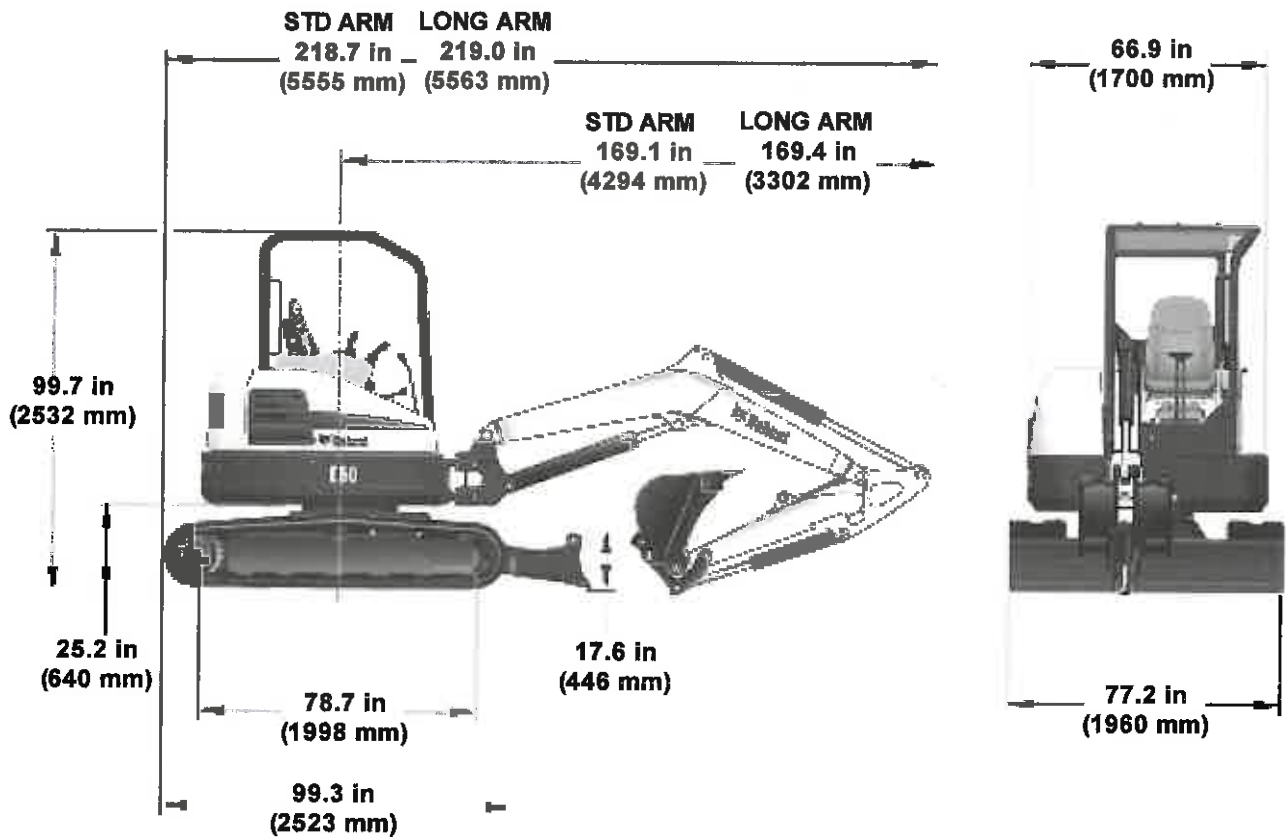
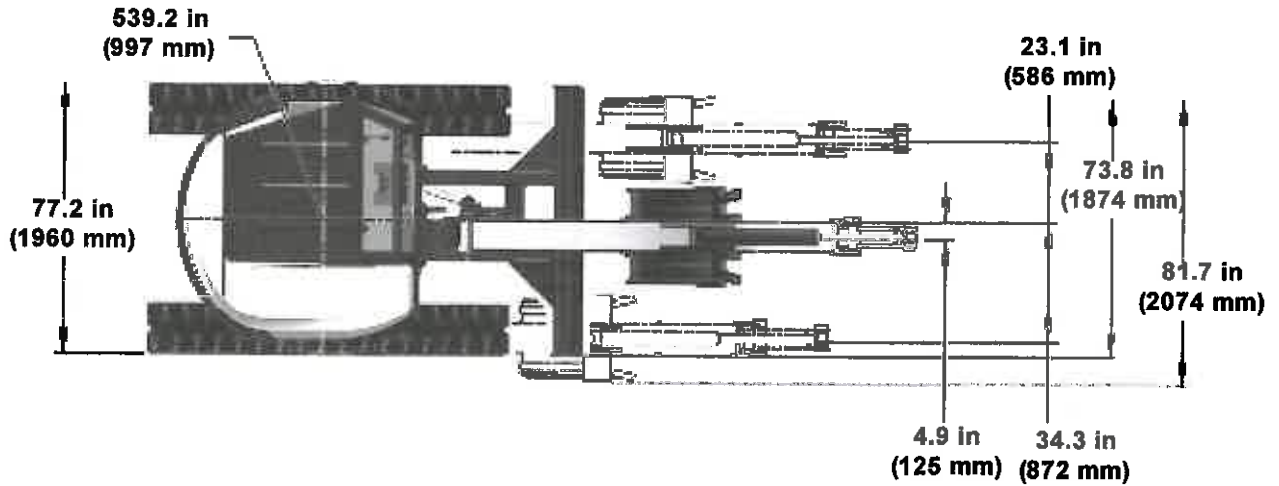

NA5066

*\*Specification(s) are based on engineering calculations and are not actual measurements. Specification(s) are provided for comparison purposes only and are subject to change without notice. Specification(s) for your individual Bobcat equipment will vary based on normal variations in design, manufacturing, operating conditions, and other factors.*

## EXCAVATOR SPECIFICATIONS (CONT'D)

### E50 Excavator Machine Dimensions - Standard Arm

- All dimensions are shown in inches. Respective metric dimensions are given in millimeters enclosed by parentheses.
- Where applicable, specifications conform to SAE or ISO standards and are subject to change without notice.

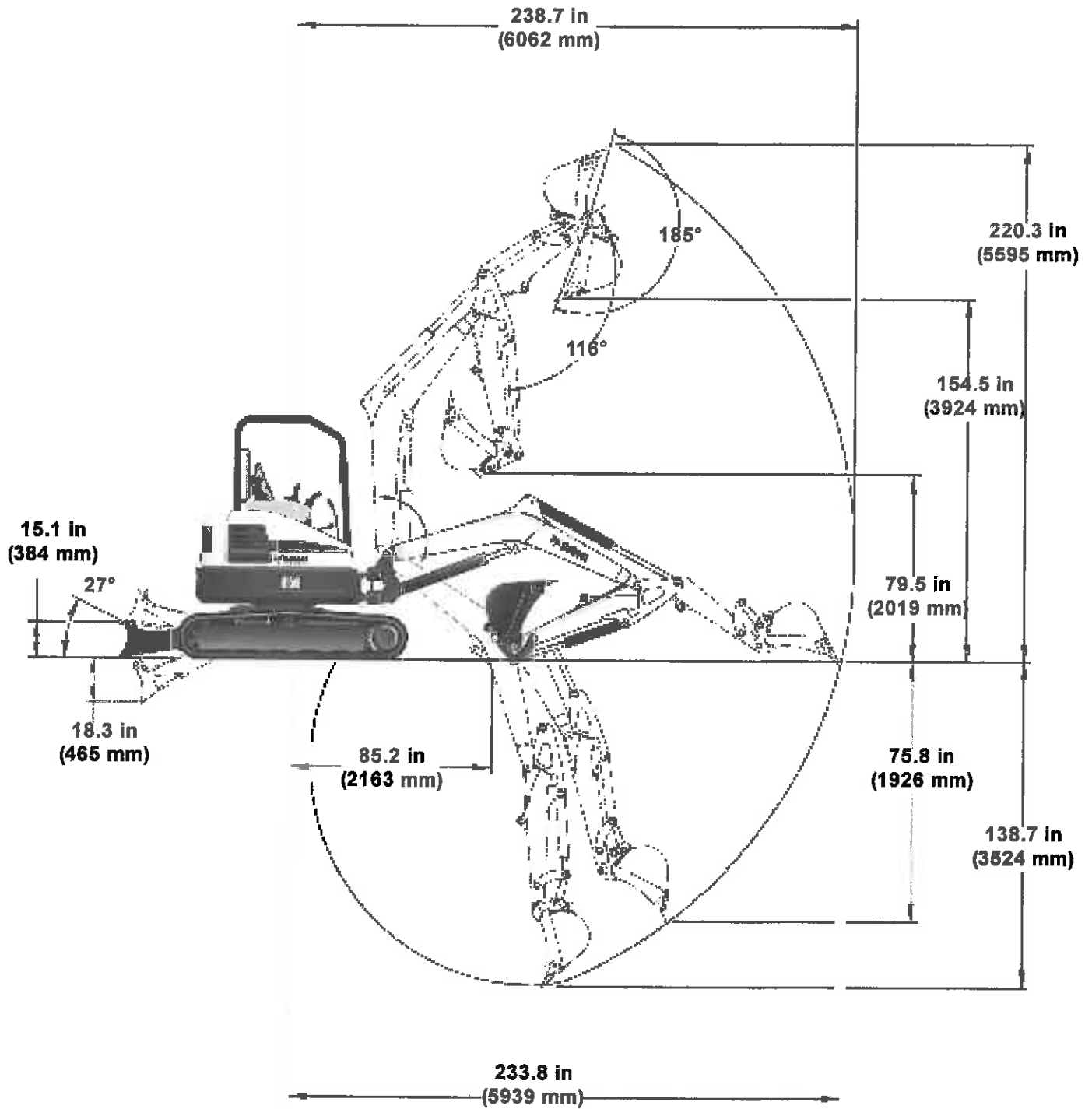

## EXCAVATOR SPECIFICATIONS (CONT'D)

### E50 Excavator Machine Dimensions - Long Arm

- All dimensions are shown in inches. Respective metric dimensions are given in millimeters enclosed by parentheses.
- Where applicable, specifications conform to SAE or ISO standards and are subject to change without notice.

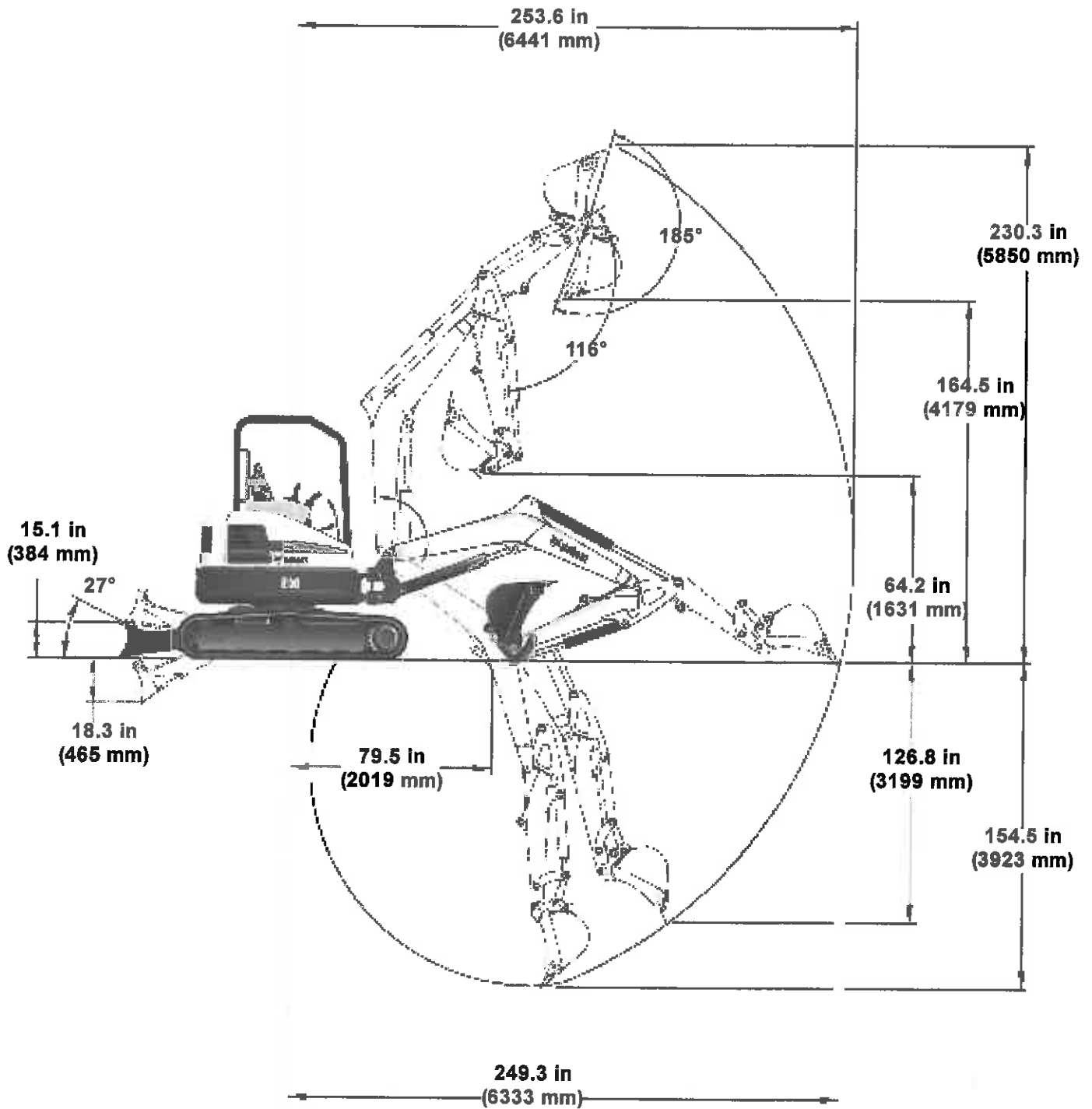



## EXCAVATOR SPECIFICATIONS (CONT'D)

### E50 Excavator Machine Dimensions - Angle Blade

- All dimensions are shown in inches. Respective metric dimensions are given in millimeters enclosed by parentheses.
- Where applicable, specifications conform to SAE or ISO standards and are subject to change without notice.

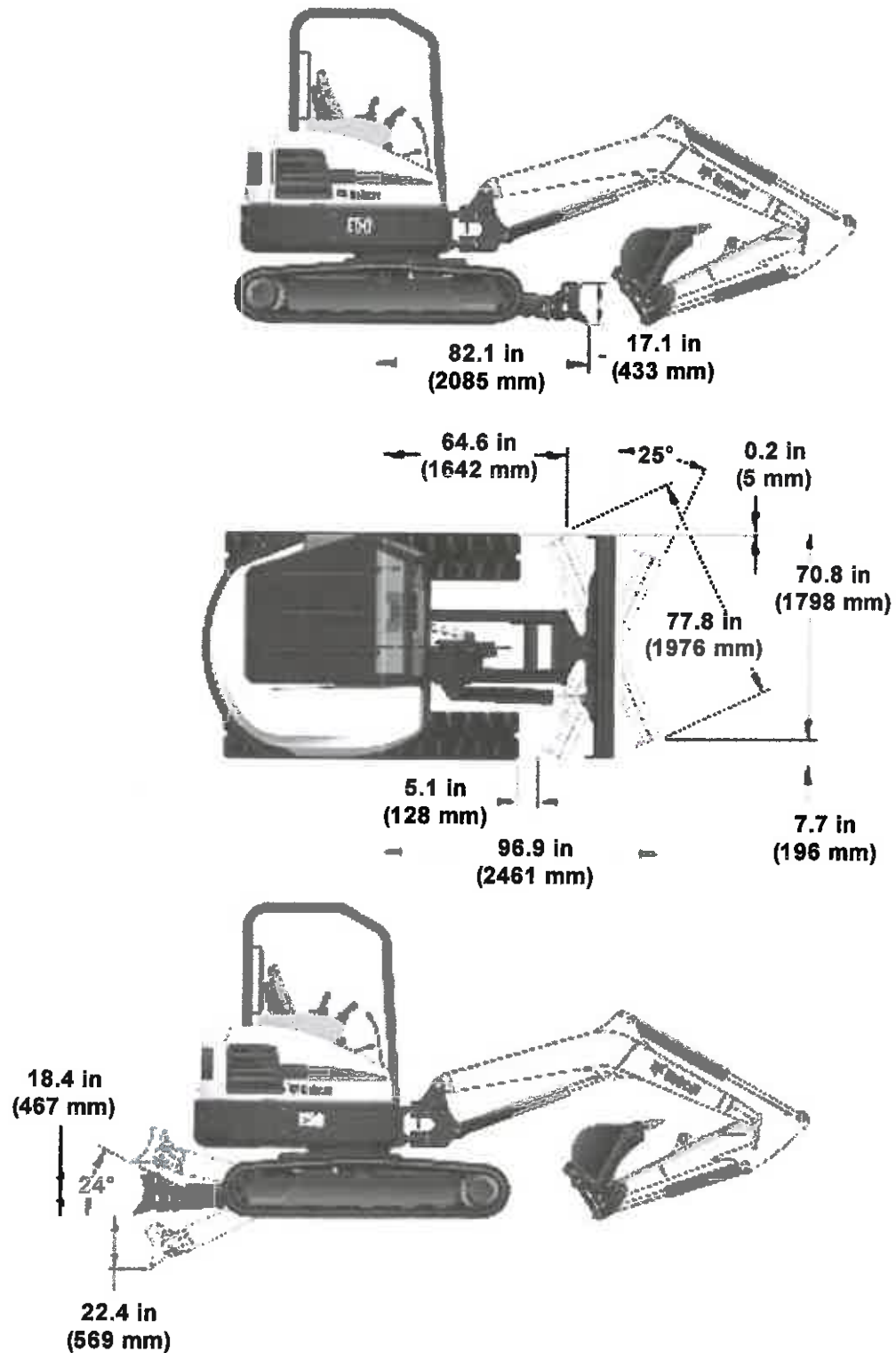

## EXCAVATOR SPECIFICATIONS (CONT'D)

### Performance

E50	
Operating weight (canopy w/ rubber tracks, and 24 in (610 mm) bucket)	10677 lb (4843 kg)
If equipped with the following, add:	<p>Steel tracks, add 289 lb (131kg);  Cab w/Heater, add 267 lb (121 kg);  Cab w/HVAC, add 309 lb (140 kg);  Long Arm (with additional counterweight), add 518 lb (235 kg);  Additional Counterweight 450 lb (204 kg);  Angle Blade, add 346 lb (157 kg)</p>
Travel Speed (Low / High)	1.9 mph / 3.1 mph (3,1 kph / 5,0 kph)
Digging Force (per ISO 6015)	
With Standard Arm	<p>Arm - 6744 lbf (29997 N)  Bucket - 8977 lbf (39930 N)</p>
With Long Arm	<p>Arm - 5751 lbf (25580 N)  Bucket - 8977 lbf (39930 N)</p>
Boom Swing	<p>Left 75°</p> <p>Right 50°</p>

### Controls

Steering	Two hand levers (optional foot pedals)
Hydraulics	Two hand operated levers (joysticks) control boom, bucket, arm and upperstructure slew
Blade	Hand lever
Angle Blade (If Equipped)	Switch on blade lever
Two Speed	Switch on blade lever
Boom Switch	Electric switch in left joystick
Auxiliary Hydraulics	Electric switch in right joystick
Auxiliary Pressure Release	Electric switch in right joystick
Engine	Engine speed control dial with auto idle feature, key type start switch
Starting Aid	Glow Plugs - activated by key switch
Brakes	
Travel	
Service & Parking	Hydraulic lock in motor circuit
Swing	
Service	Hydraulic lock on motor
Holding	Spring applied - hydraulic release

## EXCAVATOR SPECIFICATIONS (CONT'D)

### Engine

Make/Model	2.4L Bobcat Engine
Fuel/Cooling	Diesel / Liquid
Horsepower @ 2200 RPM	49.8 hp (37,1Kw)
Torque @ 1600 RPM	151.2 ft-lb (205 N•m)
Number Of Cylinders	4
Displacement	146 ci 2,392 L)
Bore/Stroke	3.54 x 3.70 in (90 x 94 mm)
Lubrication	Pressure System with Filter
Crankcase Ventilation	Closed Breathing
Air Cleaner	Dry replaceable paper dual cartridge
Ignition	Diesel-Compression
Low Idle Speed	1220 rpm +/- 25 rpm
High Idle Speed	2200 rpm
Engine Coolant	Propylene Glycol / water mixture (53% PG / 47% water)

### Hydraulic System

Pump Type	Engine driven, single outlet, variable displacement, load sensing, torque limited, piston pump
Pump Capacity Piston Pump	36.6 U.S. gpm (138,5 Lpm)
Auxiliary Flow (Aux3)	20.0 U.S. gpm (75,7 Lpm)
Auxiliary Flow - 2nd Aux (Female coupler) (Male Coupler)	12.0 U.S. U.S. gpm (45,4 L/min) 9.0 U.S. gpm (34,1 L/min)
Hydraulic Filter	Full flow replaceable, 3 micron synthetic media element
Control Valve	closed center, individually compensated
System Relief Pressure Slew Circuit Boom, Blade, Arm, Bucket, Boom Swing, Auxiliary Joystick Control Pressure	3625 psi (250 bar) 3045 psi (210 bar) 435 psi (30 bar)
Auxiliary Port Relief, Male And Female Couplers	4206 psi (290 bar)
Case Drain	25 psi (1,7 bar)

## EXCAVATOR SPECIFICATIONS (CONT'D)

### Hydraulic Cylinders

Cylinder	Bore	Rod	Stroke
Boom (cushion up)	4.00 in (101,6 mm)	2.25 in (57,1 mm)	27.45 in (697 mm)
Arm (cushion retract / extend)	3.50 in (88,9 mm)	2.25 in (57,1 mm)	29.82 in (757 mm)
Bucket	3.25 in (82,6 mm)	2.00 in (50,8 mm)	20.63 in (524 mm)
Boom Swing	3.75 in (95,2 mm)	2.00 in (50,8 mm)	19.32 in (491 mm)
Blade	4.00 in (101,6 mm)	2.00 in (50,8 mm)	7.68 in (195 mm)
Angle Blade (If equipped)	2.50 in (63,5 mm)	1.50 in (38,1 mm)	16.65 in (423 mm)

### Hydraulic Cycle Times

Bucket Curl	2.6 Seconds
Bucket Dump	1.8 Seconds
Arm Retract	3.1 Seconds
Arm Extend	3.1 Seconds
Boom Raise	4.8 Seconds
Boom Lower	4.6 Seconds
Boom Swing Left	4.4 Seconds
Boom Swing Right	4.6 Seconds
Blade Raise	3.1 Seconds
Blade Lower	2.7 Seconds
Angle Blade Left (If equipped)	1.9 Seconds
Angle Blade Right (If equipped)	2.0 Seconds

### Electrical

Starting Aid	Glow Plugs
Alternator	12 volts, 90 Amp open frame w/ internal regulator
Battery	12 volts - 530 CCA @ 00F (-180C)
Starter	12 volts; gear reduction 2.7 hp (2.0 kw)
Instrumentation	Fuel gauge, audible alarm, visual warning for engine functions and hourmeter
Lights	37.5 watt (2)

## EXCAVATOR SPECIFICATIONS (CONT'D)

### Drive System

Final Drive	Each track is driven by hydrostatic axial piston motor
Type of Reduction	56.4:1 two stage planetary

### Slew System

Slew Motor	Axial piston connected to a planetary drive
Slew Circle	Single row shear type ball bearing with internal gear
Slew Speed	9.0 rpm

### Undercarriage

Crawler Track Design	Sealed track rollers with boxed section track roller frame, grease type track adjuster with shock absorbing recoil spring
Width of crawler	77.2 in (1960 mm)

### Capacities

Fuel Tank	21.1 U.S. gal (79,9 L)
Hydraulic Reservoir Only (Center of Sight Glass)	Tank Cap. 4.0 U.S. gal (15,1 L)
Hydraulic System (with Reservoir)	14.5 U.S. gal (54,9 L)
Cooling System	2.2 U.S. gal (8,3 L)
Engine Oil and Filter	7.5 qt (7,1 L)
Final Drive (each)	1.1 qt (1,0 L)

### Tracks

Type	Rubber	Steel
Width	15.7 in (400 mm)	15.7 in (400 mm)
Number of Track Rollers (per side)	5	5

### Ground Pressure

Rubber Tracks - Standard Arm Long Arm	3.95 psi (27,2 kPa) (0,272 bar) 4.05 psi (27,9 kPa) (0,280 bar)
Steel Tracks - Standard Arm Long Arm	4.14 psi (28,5 kPa) (0,285 bar) 4.25 psi (29,3 kPa) (0,293 bar)

# Lift Charts

## Standard Arm

### WARNING

**OVERLOAD CAN TIP THE EXCAVATOR AND CAUSE INJURY OR DEATH**

- Do not lift or hold any load that exceeds these ratings at their specified load radii and height.
- Total rated load is shown. The weight of all lifting devices must be deducted to determine the net load that can be lifted.



Where applicable, specifications conform to ISO Standards. Specifications are subject to change without notice. Lift Point is bucket hinge point with standard bucket attached and bucket cylinder fully extended.

### EXCAVATOR MODEL E50

<b>CIRCUIT PRESSURES</b>		<b>BOOM LENGTH</b>	2775 mm (109.3 in)
WORKING	250 bar (3625 psi)	<b>ARM LENGTH</b>	1625 mm (64.0 in)
HOLDING	280 bar (4206 psi)	<b>COUNTERWEIGHT</b>	750 kg (1653 lb)
		<b>STANDARD BUCKET</b>	610 mm (24.0 in)
			142 kg (313 lb)

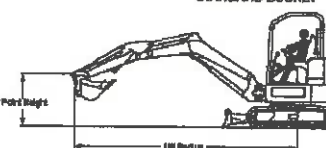

LIFT POINT HEIGHT	RATED LIFT CAPACITY OVER BLADE, BLADE DOWN - kg (lb)				RATED LIFT CAPACITY OVER BLADE, BLADE UP - kg (lb)				RATED LIFT CAPACITY OVER SIDE, BLADE UP - kg (lb)			
	LIFT RADIUS - mm (in)			LIFT @ MAXIMUM RADIUS kg (lb) @ mm (in)	LIFT RADIUS - mm (in)			LIFT @ MAXIMUM RADIUS kg (lb) @ mm (in)	LIFT RADIUS - mm (in)			LIFT @ MAXIMUM RADIUS kg (lb) @ mm (in)
	2000 (78.7)	3000 (118.1)	4000 (157.5)		2000 (78.7)	3000 (118.1)	4000 (157.5)		2000 (78.7)	3000 (118.1)	4000 (157.5)	
4000 (157.5)			*967 (2131) @ 4075 (160)				*967 (2131) @ 4075 (160)				562 (1239) @ 4075 (160)	522 (1151) @ 4075 (160)
3000 (118.1)			*979 (2158) @ 4850 (191)			749 (1652) @ 4850 (191)	512 (1190) @ 4850 (191)				560 (1235) @ 4850 (191)	369 (814) @ 4850 (191)
2000 (78.7)	*1603 (3534)	*1246 (2746)	*1117 (2462) @ 5250 (207)		1181 (2606) @ 5250 (207)	708 (1561) @ 5250 (207)	428 (944) @ 5250 (207)		896 (1954) @ 5250 (207)	537 (1185) @ 5250 (207)	296 (652) @ 5250 (207)	
1000 (39.4)	*2454 (5411)	*1559 (3438) @ 5325 (210)	*1184 (2611) @ 5325 (210)		1028 (2268) @ 5325 (210)	658 (1450) @ 5325 (210)	398 (877) @ 5325 (210)		794 (1750) @ 5325 (210)	485 (1071) @ 5325 (210)	280 (617) @ 5325 (210)	
Ground	*2737 (6034)	*1760 (3880) @ 5175 (204)	*1259 (2775) @ 5175 (204)		1013 (2234) @ 5175 (204)	635 (1399) @ 5175 (204)	413 (911) @ 5175 (204)		730 (1610) @ 5175 (204)	451 (995) @ 5175 (204)	289 (637) @ 5175 (204)	
-1000 (-39.4)	*4023 (8870)	*2652 (5847) @ 4705 (185)	*1717 (3786) @ 4705 (185)	1988 (4384) @ 4705 (185)	944 (2082) @ 4705 (185)	627 (1382) @ 4705 (185)	490 (1081) @ 4705 (185)	1378 (3039) @ 4705 (185)	734 (1620) @ 4705 (185)	454 (1002) @ 4705 (185)	343 (757) @ 4705 (185)	

\* Rated Hydraulic Lift Capacity

76222 SW 7108424 enUS

## Standard Arm -- Add-on Counterweight

### WARNING

**OVERLOAD CAN TIP THE EXCAVATOR AND CAUSE INJURY OR DEATH**

- Do not lift or hold any load that exceeds these ratings at their specified load radii and height.
- Total rated load is shown. The weight of all lifting devices must be deducted to determine the net load that can be lifted.



Where applicable, specifications conform to ISO Standards. Specifications are subject to change without notice. Lift Point is bucket hinge point with standard bucket attached and bucket cylinder fully extended.

### EXCAVATOR MODEL E50

<b>CIRCUIT PRESSURES</b>		<b>BOOM LENGTH</b>	2775 mm (109.3 in)
WORKING	250 bar (3625 psi)	<b>ARM LENGTH</b>	1625 mm (64.0 in)
HOLDING	280 bar (4206 psi)	<b>COUNTERWEIGHT</b>	970 kg (2138 lb)
		<b>STANDARD BUCKET</b>	610 mm (24.0 in)
			142 kg (313 lb)

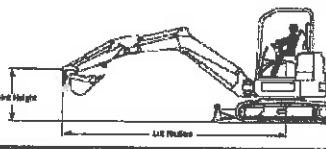

LIFT POINT HEIGHT	RATED LIFT CAPACITY OVER BLADE, BLADE DOWN - kg (lb)				RATED LIFT CAPACITY OVER BLADE, BLADE UP - kg (lb)				RATED LIFT CAPACITY OVER SIDE, BLADE UP - kg (lb)			
	LIFT RADIUS - mm (in)			LIFT @ MAXIMUM RADIUS kg (lb) @ mm (in)	LIFT RADIUS - mm (in)			LIFT @ MAXIMUM RADIUS kg (lb) @ mm (in)	LIFT RADIUS - mm (in)			LIFT @ MAXIMUM RADIUS kg (lb) @ mm (in)
	2000 (78.7)	3000 (118.1)	4000 (157.5)		2000 (78.7)	3000 (118.1)	4000 (157.5)		2000 (78.7)	3000 (118.1)	4000 (157.5)	
4000 (157.5)			*967 (2131) @ 4075 (160)				*967 (2131) @ 4075 (160)				635 (1399) @ 4075 (160)	615 (1359) @ 4075 (160)
3000 (118.1)			*979 (2158) @ 4850 (191)			*879 (1939) @ 4850 (191)	593 (1307) @ 4850 (191)				654 (1442) @ 4850 (191)	417 (919) @ 4850 (191)
2000 (78.7)	*1603 (3534)	*1246 (2746)	*1117 (2462) @ 5250 (207)		1803 (3984) @ 5250 (207)	818 (1804) @ 5250 (207)	497 (1096) @ 5250 (207)		918 (2023) @ 5250 (207)	577 (1273) @ 5250 (207)	348 (767) @ 5250 (207)	
1000 (39.4)	*2454 (5411)	*1559 (3438) @ 5325 (210)	*1184 (2611) @ 5325 (210)		1158 (2554) @ 5325 (210)	765 (1686) @ 5325 (210)	467 (1030) @ 5325 (210)		822 (1813) @ 5325 (210)	591 (1172) @ 5325 (210)	321 (706) @ 5325 (210)	
Ground	*2737 (6034)	*1760 (3880) @ 5175 (204)	*1259 (2775) @ 5175 (204)		1082 (2386) @ 5175 (204)	721 (1591) @ 5175 (204)	482 (1062) @ 5175 (204)		746 (1644) @ 5175 (204)	520 (1147) @ 5175 (204)	317 (700) @ 5175 (204)	
-1000 (-39.4)	*4023 (8870)	*2652 (5847) @ 4705 (185)	*1717 (3786) @ 4705 (185)	2329 (5134) @ 4705 (185)	1090 (2403) @ 4705 (185)	723 (1583) @ 4705 (185)	565 (1248) @ 4705 (185)	1438 (3170) @ 4705 (185)	768 (1685) @ 4705 (185)	512 (1130) @ 4705 (185)	401 (885) @ 4705 (185)	

\* Rated Hydraulic Lift Capacity

77741 SW 7108424 enUS

# Long Arm

## WARNING

**OVERLOAD CAN TIP THE EXCAVATOR AND CAUSE INJURY OR DEATH**

- Do not lift or hold any load that exceeds these ratings at their specified load radii and height.
- Total rated load is shown. The weight of all lifting devices must be deducted to determine the net load that can be lifted.



Where applicable, specifications conform to ISO Standards. Specifications are subject to change without notice. Lift Point is bucket hinge point with standard bucket attached and bucket cylinder fully extended.

### EXCAVATOR MODEL E50

<b>CIRCUIT PRESSURES</b>		<b>BOOM LENGTH</b>	2770 mm (109.3 in)
<b>WORKING</b>	280 bar (3825 psi)	<b>ARM LENGTH</b>	1925 mm (75.9 in)
<b>HOLDING</b>	280 bar (4205 psi)	<b>COUNTER WEIGHT</b>	970 kg (2138 lb)
		<b>STANDARD BUCKET</b>	810 mm (24.0 in)
			142 kg (313 lb)

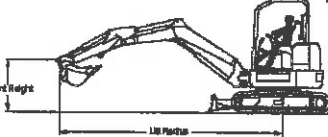

LIFT POINT HEIGHT	RATED LIFT CAPACITY OVER BLADE, BLADE DOWN - kg (lb)						RATED LIFT CAPACITY OVER BLADE, BLADE UP - kg (lb)						RATED LIFT CAPACITY OVER SIDE, BLADE UP - kg (lb)					
	LIFT RADIUS - mm (in)			LIFT @ MAXIMUM RADIUS, kg (lb) @ mm (in)	LIFT RADIUS - mm (in)			LIFT @ MAXIMUM RADIUS, kg (lb) @ mm (in)	LIFT RADIUS - mm (in)			LIFT @ MAXIMUM RADIUS, kg (lb) @ mm (in)						
	3000 (118.1)	4000 (157.5)	5000 (196.9)		3000 (118.1)	4000 (157.5)	5000 (196.9)		3000 (118.1)	4000 (157.5)	5000 (196.9)							
4000 (157.5)		*683 (1506)		*554 (1221) @ 4800 (181)		*683 (1506)		470 (1037) @ 4800 (181)		*683 (1506)		482 (1062) @ 4800 (181)						
3000 (118.1)		*750 (1673)	*729 (1608)	*575 (1268) @ 5150 (203)		*750 (1673)	550 (1214)	498 (1099) @ 5150 (203)		692 (1526)	432 (953)	371 (818) @ 5150 (203)						
2000 (78.7)	*1202 (2649)	*996 (2196)	*973 (2146)	*759 (1673) @ 5480 (216)	*1202 (2649)	*996 (2196)	507 (1117)	424 (936) @ 5480 (216)	1090 (2403)	661 (1459)	420 (926)	302 (666) @ 5480 (216)						
1000 (39.4)	*2182 (4749)	*1406 (3100)	*1131 (2494)	*932 (2054) @ 5570 (219)	1178 (2597)	730 (1610)	482 (1062)	394 (868) @ 5570 (219)	920 (2049)	602 (1329)	386 (852)	275 (607) @ 5570 (219)						
Ground	*2688 (5926)	*1696 (3716)	*1268 (2796)	*1126 (2482) @ 5400 (213)	1124 (2479)	700 (1543)	478 (1054)	415 (915) @ 5400 (213)	906 (1998)	568 (1231)	366 (808)	289 (637) @ 5400 (213)						
-1000 (-39.4)	*2777 (6122)	*1770 (3902)	*1238 (2729)	*1215 (2678) @ 5050 (199)	1139 (2512)	696 (1534)	476 (1049)	481 (1061) @ 5050 (199)	876 (1931)	570 (1256)	367 (809)	340 (750) @ 5050 (199)						

\* Rated Hydraulic Lift Capacity

7622 SW 7188436 enUS

# WARRANTY

## Bobcat Excavators

Bobcat Company warrants to its authorized dealers and authorized dealers of Bobcat Equipment Ltd., who in turn warrant to the owner, that each new Bobcat Excavator will be free from proven defects in material and workmanship with respect to (i) all components of the product except as otherwise specified herein for twelve (12) months, (ii) tracks for twelve (12) months on a prorated basis based on the remaining depth of the track at the time any defect is discovered, and (iii) Bobcat brand batteries, for an additional twelve (12) months after the initial twelve month warranty period, provided that Bobcat Company shall only reimburse a fixed portion of the cost of replacing the battery during such additional twelve months. The foregoing time periods shall all commence after delivery by the authorized Bobcat dealer to the original buyer.

During the warranty period, the authorized Bobcat dealer shall repair or replace, at Bobcat Company's option, without charge for parts and labor, any part of the Bobcat product except as otherwise specified herein which falls because of defects in material or workmanship. The owner shall provide the authorized Bobcat dealer with prompt written notice of the defect and allow reasonable time for repair or replacement. Bobcat Company may, at its option, require failed parts to be returned to the factory. Travel time of mechanics and transportation of the Bobcat product to the authorized Bobcat dealer for warranty work are the responsibility of the owner. The remedies provided in this warranty are exclusive.

This warranty does not cover replacement of scheduled service items such as oil, filters, tune-up parts, and other high-wear items. This warranty does not cover damages resulting from abuse, accidents, alterations, use of the Bobcat product with any accessory or attachment not approved by Bobcat Company, air flow obstructions, or failure to maintain or use the Bobcat product according to the instructions applicable to it.

**THIS WARRANTY IS EXCLUSIVE AND IN LIEU OF ALL OTHER WARRANTIES AND CONDITIONS, EXCEPT THE WARRANTY OF TITLE. BOBCAT COMPANY DISCLAIMS ALL OTHER WARRANTIES AND CONDITIONS, EXPRESS OR IMPLIED, INCLUDING ANY IMPLIED WARRANTIES OR CONDITIONS OF MERCHANTABILITY OR FITNESS FOR A PARTICULAR PURPOSE. IN NO EVENT SHALL BOBCAT COMPANY OR THE AUTHORIZED BOBCAT DEALER BE LIABLE FOR ANY SPECIAL, INCIDENTAL, INDIRECT OR CONSEQUENTIAL DAMAGES, WHATSOEVER, INCLUDING, BUT NOT LIMITED TO, LOSS OR INTERRUPTION OF BUSINESS, LOST PROFITS, OR LOSS OF MACHINE USE, WHETHER BASED ON CONTRACT, WARRANTY, TORT, NEGLIGENCE, STRICT LIABILITY, STATUTE OR OTHERWISE, EVEN IF BOBCAT COMPANY OR THE AUTHORIZED BOBCAT DEALER HAS BEEN ADVISED OF THE POSSIBILITY OF SUCH DAMAGES. THE TOTAL LIABILITY OF BOBCAT COMPANY AND THE AUTHORIZED BOBCAT DEALERS WITH RESPECT TO THE PRODUCT AND SERVICES FURNISHED HEREUNDER SHALL NOT EXCEED THE PURCHASE PRICE OF THE PRODUCT UPON WHICH SUCH LIABILITY IS BASED.**



**Bobcat®**





**Bobcat**

**Compact Excavators**



**Bobcat.**

of Advantage Valley

**SALES • SERVICE • RENTAL**

Cross Lanes, WV 25313

304-776-9100 • 1-866-426-2228

[www.bobcatwv.com](http://www.bobcatwv.com)

***One Tough Animal***