



Purchasing Division  
 2019 Washington Street East  
 Post Office Box 50130  
 Charleston, WV 25305-0130

State of West Virginia  
 Request for Quotation  
 13 - Equipment

Proc Folder: 339026

Doc Description: Compact Excavator with Attachments

Proc Type: Central Purchase Order

Date Issued	Solicitation Closes	Solicitation No	Version
2017-08-14	2017-09-05 13:30:00	CRFQ 0313 DEP1800000001	1

**BID RECEIVING LOCATION**

BID CLERK  
 DEPARTMENT OF ADMINISTRATION  
 PURCHASING DIVISION  
 2019 WASHINGTON ST E  
 CHARLESTON WV 25305  
 US

**VENDOR**

Vendor Name, Address and Telephone Number:  
*C.I. Walker Machinery Co.*  
*P.O. Box 2427*  
*Charleston, WV 25329*  
*(304) 949-6400*

09/12/17 11:08:58  
 WV Purchasing Division

**FOR INFORMATION CONTACT THE BUYER**

Brittany E Ingraham  
 (304) 558-2157  
 brittany.e.ingraham@wv.gov

Signature X *[Handwritten Signature]* FEIN # *55-0352647* DATE *9/11/17*

All offers subject to all terms and conditions contained in this solicitation

**ADDITIONAL INFORMATION:**

**Request for Quotation:**

The West Virginia Purchasing Division is soliciting bids on behalf of West Virginia Department of Environmental Protection (Office of Abandoned Mine Lands and Reclamation) to establish a contract for the one-time purchase of a compact excavator with attachments per the bid requirements, specifications, terms and conditions attached to this solicitation.

INVOICE TO		SHIP TO	
ENVIRONMENTAL PROTECTION OFFICE OF AML&R 601 57TH ST SE CHARLESTON WV25304 US		STATE OF WEST VIRGINIA JOBSITE - SEE SPECIFICATIONS No City WV 99999 US	

Line	Comm Ln Desc	Qty	Unit Issue	Unit Price	Total Price
1	Compact Excavator	1.00000	EA	\$ 49,194.21	\$ 49,194.21

Comm Code	Manufacturer	Specification	Model #
30190000	CAT	303SE2 CR	

**Extended Description :**  
Compact Excavator

INVOICE TO		SHIP TO	
ENVIRONMENTAL PROTECTION OFFICE OF AML&R 601 57TH ST SE CHARLESTON WV25304 US		STATE OF WEST VIRGINIA JOBSITE - SEE SPECIFICATIONS No City WV 99999 US	

Line	Comm Ln Desc	Qty	Unit Issue	Unit Price	Total Price
2	12" Digging Bucket	1.00000	EA	\$ 638.00	\$ 638.00

Comm Code	Manufacturer	Specification	Model #
30190000	CAT	12" Bucket	

**Extended Description :**  
12" Digging Bucket

INVOICE TO		SHIP TO	
ENVIRONMENTAL PROTECTION OFFICE OF AML&R 601 57TH ST SE CHARLESTON WV25304 US		STATE OF WEST VIRGINIA JOBSITE - SEE SPECIFICATIONS  No City WV 99999 US	

Line	Comm Ln Desc	Qty	Unit Issue	Unit Price	Total Price
3	24" Digging Bucket	1.00000	EA	\$ 800.00	\$ 800.00

Comm Code	Manufacturer	Specification	Model #
30190000	CAT	24" Bucket	

Extended Description :  
24" Digging Bucket

INVOICE TO		SHIP TO	
ENVIRONMENTAL PROTECTION OFFICE OF AML&R 601 57TH ST SE CHARLESTON WV25304 US		STATE OF WEST VIRGINIA JOBSITE - SEE SPECIFICATIONS  No City WV 99999 US	

Line	Comm Ln Desc	Qty	Unit Issue	Unit Price	Total Price
4	36" Grading Bucket	1.00000	EA	\$ 4555.00	\$ 4555.00

Comm Code	Manufacturer	Specification	Model #
30190000	Werk Brau	WTB36	

Extended Description :  
36" Grading Bucket

INVOICE TO		SHIP TO	
ENVIRONMENTAL PROTECTION OFFICE OF AML&R 601 57TH ST SE CHARLESTON WV25304 US		STATE OF WEST VIRGINIA JOBSITE - SEE SPECIFICATIONS  No City WV 99999 US	

Line	Comm Ln Desc	Qty	Unit Issue	Unit Price	Total Price
5	Root Rake	1.00000	EA	\$ 1151.00	\$ 1151.00

Comm Code	Manufacturer	Specification	Model #
30190000	TAG	2405 R	

Extended Description :

Root Rake

INVOICE TO	SHIP TO
ENVIRONMENTAL PROTECTION OFFICE OF AML&R 601 57TH ST SE CHARLESTON WV25304 US	STATE OF WEST VIRGINIA JOBSITE - SEE SPECIFICATIONS No City WV 99999 US

Line	Comm Ln Desc	Qty	Unit Issue	Unit Price	Total Price
6	Hydraulic Brush Cutter	1.00000	EA	\$ 4086. <sup>00</sup>	\$ 4086. <sup>00</sup>

Comm Code	Manufacturer	Specification	Model #
30190000	Bushmaster	MX401-42SL	

Extended Description :

Hydraulic Brush Cutter

INVOICE TO	SHIP TO
ENVIRONMENTAL PROTECTION OFFICE OF AML&R 601 57TH ST SE CHARLESTON WV25304 US	STATE OF WEST VIRGINIA JOBSITE - SEE SPECIFICATIONS No City WV 99999 US

Line	Comm Ln Desc	Qty	Unit Issue	Unit Price	Total Price
7	Hydraulic Plate Compactor	1.00000	EA	\$ 5141. <sup>00</sup>	\$ 5141. <sup>00</sup>

Comm Code	Manufacturer	Specification	Model #
30190000	CAT	CVPI6	

Extended Description :

Hydraulic Plate Compactor

INVOICE TO		SHIP TO	
ENVIRONMENTAL PROTECTION OFFICE OF AML&R 601 57TH ST SE CHARLESTON WV25304 US		STATE OF WEST VIRGINIA JOBSITE - SEE SPECIFICATIONS  No City WV 99999 US	

Line	Comm Ln Desc	Qty	Unit Issue	Unit Price	Total Price
8	Hydraulic Hammer/Breaker	1.00000	EA	\$7428.00	\$7428.00

Comm Code	Manufacturer	Specification	Model #
30190000	CAT	H55E	

Extended Description :  
Hydraulic Hammer/Breaker

INVOICE TO		SHIP TO	
ENVIRONMENTAL PROTECTION OFFICE OF AML&R 601 57TH ST SE CHARLESTON WV25304 US		STATE OF WEST VIRGINIA JOBSITE - SEE SPECIFICATIONS  No City WV 99999 US	

Line	Comm Ln Desc	Qty	Unit Issue	Unit Price	Total Price
9	3/8" Ratchet Binders	5.00000	EA	\$67.40	\$337.00

Comm Code	Manufacturer	Specification	Model #
30190000	REDWING	3/8" Ratchet Binders	

Extended Description :  
3/8" Ratchet Binders

INVOICE TO		SHIP TO	
ENVIRONMENTAL PROTECTION OFFICE OF AML&R 601 57TH ST SE CHARLESTON WV25304 US		STATE OF WEST VIRGINIA JOBSITE - SEE SPECIFICATIONS  No City WV 99999 US	

Line	Comm Ln Desc	Qty	Unit Issue	Unit Price	Total Price
10	3/8" X 20' Chain with Hooks	5.00000	EA	\$44.60	\$223.00

Comm Code	Manufacturer	Specification	Model #
30190000	REDWING	3/8" x 20' Chain w/ Hooks	

**Extended Description :**

3/8" X 20' Chain with Hooks

INVOICE TO	SHIP TO
ENVIRONMENTAL PROTECTION OFFICE OF AML&R 601 57TH ST SE CHARLESTON WV25304 US	STATE OF WEST VIRGINIA JOBSITE - SEE SPECIFICATIONS No City WV 99999 US

Line	Comm Ln Desc	Qty	Unit Issue	Unit Price	Total Price
11	2" Wide Lifting Straps 4' Long	2.00000	EA	\$ 12.00	\$ 24.00

Comm Code	Manufacturer	Specification	Model #
30190000	REDWING	2" Wide Lifting Straps 4' Long	

**Extended Description :**

2" Wide Lifting Straps 4' Long

INVOICE TO	SHIP TO
ENVIRONMENTAL PROTECTION OFFICE OF AML&R 601 57TH ST SE CHARLESTON WV25304 US	STATE OF WEST VIRGINIA JOBSITE - SEE SPECIFICATIONS No City WV 99999 US

Line	Comm Ln Desc	Qty	Unit Issue	Unit Price	Total Price
12	2" Wide Lifting Straps 10' Long	3.00000	EA	\$ 23.00	\$ 69.00

Comm Code	Manufacturer	Specification	Model #
30190000	REDWING	2" Wide Lifting Straps 10' Long	

**Extended Description :**

2" Wide Lifting Straps 10' Long

INVOICE TO		SHIP TO	
ENVIRONMENTAL PROTECTION OFFICE OF AML&R 601 57TH ST SE CHARLESTON WV25304 US		STATE OF WEST VIRGINIA JOBSITE - SEE SPECIFICATIONS  No City WV 99999 US	

Line	Comm Ln Desc	Qty	Unit Issue	Unit Price	Total Price
13	Triple Leg Chain Sling	1.00000	EA	\$ 364.00	\$ 364.00

Comm Code	Manufacturer	Specification	Model #
30190000	Redwing	Triple Leg Chain Sling	

Extended Description :  
Triple Leg Chain Sling

INVOICE TO		SHIP TO	
ENVIRONMENTAL PROTECTION OFFICE OF AML&R 601 57TH ST SE CHARLESTON WV25304 US		STATE OF WEST VIRGINIA JOBSITE - SEE SPECIFICATIONS  No City WV 99999 US	

Line	Comm Ln Desc	Qty	Unit Issue	Unit Price	Total Price
14	3/4" Screw Pin Anchor Shackle	5.00000	EA	\$ 35.00	\$ 175.00

Comm Code	Manufacturer	Specification	Model #
30190000	Redwing	3/4" Screw Pin Anchor Shackle	

Extended Description :  
3/4" Screw Pin Anchor Shackle

INVOICE TO		SHIP TO	
ENVIRONMENTAL PROTECTION OFFICE OF AML&R 601 57TH ST SE CHARLESTON WV25304 US		STATE OF WEST VIRGINIA JOBSITE - SEE SPECIFICATIONS  No City WV 99999 US	

Line	Comm Ln Desc	Qty	Unit Issue	Unit Price	Total Price
15	2,500 Hour Maintenance Agreement and Comprehensive Warranty	1.00000	EA	\$ 5033.00	\$ 5033.00

Comm Code	Manufacturer	Specification	Model #
30190000	Walker Machinery Co.	2500hr Maintenance & Warranty	

**Extended Description :**

2,500 Hour Maintenance Agreement and Comprehensive Warranty



DEP180000001	<b>Document Phase</b> Final	<b>Document Description</b> Compact Excavator with Attachments	<b>Page 9</b> of 9
--------------	--------------------------------	---	-----------------------

**ADDITIONAL TERMS AND CONDITIONS**

See attached document(s) for additional Terms and Conditions



Purchasing Division  
 2019 Washington Street East  
 Post Office Box 50130  
 Charleston, WV 25305-0130

State of West Virginia  
 Request for Quotation  
 13 - Equipment

Proc Folder: 339026

Doc Description: Addendum No.01 - Compact Excavator with Attachments

Proc Type: Central Purchase Order

Date Issued	Solicitation Closes	Solicitation No	Version
2017-08-31	2017-09-12 13:30:00	CRFQ 0313 DEP1800000001	2

**BID RECEIVING LOCATION**

BID CLERK  
 DEPARTMENT OF ADMINISTRATION  
 PURCHASING DIVISION  
 2019 WASHINGTON ST E  
 CHARLESTON WV 25305  
 US

**VENDOR**

Vendor Name, Address and Telephone Number:

*C.I. Walker Machinery Co.  
 P.O. Box 2427  
 Charleston, WV 25329  
 (304) 949-6400*

**FOR INFORMATION CONTACT THE BUYER**

Brittany E Ingraham  
 (304) 558-2157  
 brittany.e.ingraham@wv.gov

Signature X  FEIN # *55-0352647* DATE *9/11/17*

All offers subject to all terms and conditions contained in this solicitation

**ADDITIONAL INFORMATION:**

**Addendum**

Addendum No.01 issued to publish and distribute the attached information to the vendor community.

\*\*\*\*\*

**Request for Quotation**

The West Virginia Purchasing Division is soliciting bids on behalf of West Virginia Department of Environmental Protection (Office of Abandoned Mine Lands and Reclamation) to establish a contract for the one-time purchase of a compact excavator with attachments per the bid requirements, specifications, terms and conditions attached to this solicitation.

INVOICE TO		SHIP TO	
ENVIRONMENTAL PROTECTION OFFICE OF AML&R 601 57TH ST SE CHARLESTON WV25304 US		STATE OF WEST VIRGINIA JOBSITE - SEE SPECIFICATIONS No City WV 99999 US	

Line	Comm Ln Desc	Qty	Unit Issue	Unit Price	Total Price
1	Compact Excavator	1.00000	EA		

Comm Code	Manufacturer	Specification	Model #
30190000			

**Extended Description :**  
Compact Excavator

INVOICE TO		SHIP TO	
ENVIRONMENTAL PROTECTION OFFICE OF AML&R 601 57TH ST SE CHARLESTON WV25304 US		STATE OF WEST VIRGINIA JOBSITE - SEE SPECIFICATIONS No City WV 99999 US	

Line	Comm Ln Desc	Qty	Unit Issue	Unit Price	Total Price
2	12" Digging Bucket	1.00000	EA		

Comm Code	Manufacturer	Specification	Model #
30190000			

**Extended Description :**  
12" Digging Bucket

INVOICE TO		SHIP TO	
ENVIRONMENTAL PROTECTION OFFICE OF AML&R 601 57TH ST SE CHARLESTON WV25304 US		STATE OF WEST VIRGINIA JOBSITE - SEE SPECIFICATIONS  No City WV 99999 US	

Line	Comm Ln Desc	Qty	Unit Issue	Unit Price	Total Price
3	24" Digging Bucket	1.00000	EA		

Comm Code	Manufacturer	Specification	Model #
30190000			

**Extended Description :**  
24" Digging Bucket

INVOICE TO		SHIP TO	
ENVIRONMENTAL PROTECTION OFFICE OF AML&R 601 57TH ST SE CHARLESTON WV25304 US		STATE OF WEST VIRGINIA JOBSITE - SEE SPECIFICATIONS  No City WV 99999 US	

Line	Comm Ln Desc	Qty	Unit Issue	Unit Price	Total Price
4	36" Grading Bucket	1.00000	EA		

Comm Code	Manufacturer	Specification	Model #
30190000			

**Extended Description :**  
36" Grading Bucket

INVOICE TO		SHIP TO	
ENVIRONMENTAL PROTECTION OFFICE OF AML&R 601 57TH ST SE CHARLESTON WV25304 US		STATE OF WEST VIRGINIA JOBSITE - SEE SPECIFICATIONS  No City WV 99999 US	

Line	Comm Ln Desc	Qty	Unit Issue	Unit Price	Total Price
5	Root Rake	1.00000	EA		

Comm Code	Manufacturer	Specification	Model #
30190000			

**Extended Description :**

Root Rake

INVOICE TO		SHIP TO	
ENVIRONMENTAL PROTECTION OFFICE OF AML&R 601 57TH ST SE CHARLESTON WV25304 US		STATE OF WEST VIRGINIA JOBSITE - SEE SPECIFICATIONS No City WV 99999 US	

Line	Comm Ln Desc	Qty	Unit Issue	Unit Price	Total Price
6	Hydraulic Brush Cutter	1.00000	EA		

Comm Code	Manufacturer	Specification	Model #
30190000			

**Extended Description :**

Hydraulic Brush Cutter

INVOICE TO		SHIP TO	
ENVIRONMENTAL PROTECTION OFFICE OF AML&R 601 57TH ST SE CHARLESTON WV25304 US		STATE OF WEST VIRGINIA JOBSITE - SEE SPECIFICATIONS No City WV 99999 US	

Line	Comm Ln Desc	Qty	Unit Issue	Unit Price	Total Price
7	Hydraulic Plate Compactor	1.00000	EA		

Comm Code	Manufacturer	Specification	Model #
30190000			

**Extended Description :**

Hydraulic Plate Compactor

INVOICE TO		SHIP TO	
ENVIRONMENTAL PROTECTION OFFICE OF AML&R 601 57TH ST SE CHARLESTON WV25304 US		STATE OF WEST VIRGINIA JOBSITE - SEE SPECIFICATIONS  No City WV 99999 US	

Line	Comm Ln Desc	Qty	Unit Issue	Unit Price	Total Price
8	Hydraulic Hammer/Breaker	1.00000	EA		

Comm Code	Manufacturer	Specification	Model #
30190000			

**Extended Description :**  
Hydraulic Hammer/Breaker

INVOICE TO		SHIP TO	
ENVIRONMENTAL PROTECTION OFFICE OF AML&R 601 57TH ST SE CHARLESTON WV25304 US		STATE OF WEST VIRGINIA JOBSITE - SEE SPECIFICATIONS  No City WV 99999 US	

Line	Comm Ln Desc	Qty	Unit Issue	Unit Price	Total Price
9	3/8" Ratchet Binders	5.00000	EA		

Comm Code	Manufacturer	Specification	Model #
30190000			

**Extended Description :**  
3/8" Ratchet Binders

INVOICE TO		SHIP TO	
ENVIRONMENTAL PROTECTION OFFICE OF AML&R 601 57TH ST SE CHARLESTON WV25304 US		STATE OF WEST VIRGINIA JOBSITE - SEE SPECIFICATIONS  No City WV 99999 US	

Line	Comm Ln Desc	Qty	Unit Issue	Unit Price	Total Price
10	3/8" X 20' Chain with Hooks	5.00000	EA		

Comm Code	Manufacturer	Specification	Model #
30190000			

**Extended Description :**  
3/8" X 20' Chain with Hooks

INVOICE TO		SHIP TO	
ENVIRONMENTAL PROTECTION OFFICE OF AML&R 601 57TH ST SE CHARLESTON WV25304 US		STATE OF WEST VIRGINIA JOBSITE - SEE SPECIFICATIONS No City WV 99999 US	

Line	Comm Ln Desc	Qty	Unit Issue	Unit Price	Total Price
11	2" Wide Lifting Straps 4' Long	2.00000	EA		

Comm Code	Manufacturer	Specification	Model #
30190000			

**Extended Description :**  
2" Wide Lifting Straps 4' Long

INVOICE TO		SHIP TO	
ENVIRONMENTAL PROTECTION OFFICE OF AML&R 601 57TH ST SE CHARLESTON WV25304 US		STATE OF WEST VIRGINIA JOBSITE - SEE SPECIFICATIONS No City WV 99999 US	

Line	Comm Ln Desc	Qty	Unit Issue	Unit Price	Total Price
12	2" Wide Lifting Straps 10' Long	3.00000	EA		

Comm Code	Manufacturer	Specification	Model #
30190000			

**Extended Description :**  
2" Wide Lifting Straps 10' Long

INVOICE TO		SHIP TO	
ENVIRONMENTAL PROTECTION OFFICE OF AML&R 601 57TH ST SE CHARLESTON WV25304 US		STATE OF WEST VIRGINIA JOBSITE - SEE SPECIFICATIONS  No City WV 99999 US	

Line	Comm Ln Desc	Qty	Unit Issue	Unit Price	Total Price
13	Triple Leg Chain Sling	1.00000	EA		

Comm Code	Manufacturer	Specification	Model #
30190000			

**Extended Description :**  
Triple Leg Chain Sling

INVOICE TO		SHIP TO	
ENVIRONMENTAL PROTECTION OFFICE OF AML&R 601 57TH ST SE CHARLESTON WV25304 US		STATE OF WEST VIRGINIA JOBSITE - SEE SPECIFICATIONS  No City WV 99999 US	

Line	Comm Ln Desc	Qty	Unit Issue	Unit Price	Total Price
14	3/4" Screw Pin Anchor Shackle	5.00000	EA		

Comm Code	Manufacturer	Specification	Model #
30190000			

**Extended Description :**  
3/4" Screw Pin Anchor Shackle

INVOICE TO		SHIP TO	
ENVIRONMENTAL PROTECTION OFFICE OF AML&R 601 57TH ST SE CHARLESTON WV25304 US		STATE OF WEST VIRGINIA JOBSITE - SEE SPECIFICATIONS  No City WV 99999 US	

Line	Comm Ln Desc	Qty	Unit Issue	Unit Price	Total Price
15	2,500 Hour Maintenance Agreement and Comprehensive Warranty	1.00000	EA		



Comm Code	Manufacturer	Specification	Model #
30190000			

**Extended Description :**

2,500 Hour Maintenance Agreement and Comprehensive Warranty

<b>DEP1800000001</b>	<b>Document Phase</b> Final	<b>Document Description</b> Addendum No.01 - Compact Excavator with Attachments	<b>Page 9</b> of 9
----------------------	--------------------------------	--	-----------------------

**ADDITIONAL TERMS AND CONDITIONS**

See attached document(s) for additional Terms and Conditions

**SOLICITATION NUMBER: CRFQ DEP1800000001**

**Addendum Number: No.01**

---

The purpose of this addendum is to modify the solicitation identified as ("Solicitation") to reflect the change(s) identified and described below.

**Applicable Addendum Category:**

- Modify bid opening date and time
- Modify specifications of product or service being sought
- Attachment of vendor questions and responses
- Attachment of pre-bid sign-in sheet
- Correction of error
- Other

**Description of Modification to Solicitation:**

This addendum is issued to modify the solicitation per the attached documentation and the following:

1. To modify the bid opening date:  
 Bid opening WAS September 5, 2017 at 1:30 PM EST  
 Bid opening IS NOW September 12, 2017 at 1:30 PM EST
2. To publish vendor questions and agency responses

No other changes.

**Additional Documentation:** Documentation related to this Addendum (if any) has been included herewith as Attachment A and is specifically incorporated herein by reference.

**Terms and Conditions:**

1. All provisions of the Solicitation and other addenda not modified herein shall remain in full force and effect.
2. Vendor should acknowledge receipt of all addenda issued for this Solicitation by completing an Addendum Acknowledgment, a copy of which is included herewith. Failure to acknowledge addenda may result in bid disqualification. The addendum acknowledgement should be submitted with the bid to expedite document processing.

# ATTACHMENT A

Compact Excavator  
CRFQ DEP1800000001  
Vendor Questions and Agency Answers

Q1.) I have a question regarding 3.1.1.20, referring to minimum digging reach of 17 feet, would you be talking about the digging radius?

A1.) Yes

Q2.) 3.1.1.5 Our machine does not have a hydraulic accumulator to release pressure, is this OK?

A2.) Specification 3.1.1.5 requires a device such as a hydraulic accumulator to release pressure while changing the attachment hydraulic lines.

Q3.) 3.1.1.15 Our machine does not have an electrical cut off switch, is this OK? All of our keys are keyed alike

A3.) No, Specification 3.1.1.5 requires an electrical cut off switch. All locks except master switch shall be keyed alike.

Q4.) 3.1.1.3. I have concern that with the front window guard along with the coupler that the weight will greatly exceed 8900 lbs. With the angle blade, thumb and bucket we will be right at 8953. Is this OK??

A4.) No, Specification 3.1.1.3 states that unit must be between 8,200 to 8,900-pound transport weight. Transport weight shall include excavator full of fluids, thumb, and (Item 3.1.3) a 24" digging bucket.

Q5.) I have a question regarding 3.1.1.3, would 9,000LB Transport Weight be accepted? In the specs you are asking for 8,900LB Transport Weight.

A5.) No, a 9,000lb transport weight will not be accepted.

**ADDENDUM ACKNOWLEDGEMENT FORM**  
**SOLICITATION NO.:**

**Instructions:** Please acknowledge receipt of all addenda issued with this solicitation by completing this addendum acknowledgment form. Check the box next to each addendum received and sign below. Failure to acknowledge addenda may result in bid disqualification.

**Acknowledgment:** I hereby acknowledge receipt of the following addenda and have made the necessary revisions to my proposal, plans and/or specification, etc.

**Addendum Numbers Received:**

(Check the box next to each addendum received)

- |  |  |
|--|--|
| <input checked="" type="checkbox"/> Addendum No. 1 | <input type="checkbox"/> Addendum No. 6  |
| <input type="checkbox"/> Addendum No. 2            | <input type="checkbox"/> Addendum No. 7  |
| <input type="checkbox"/> Addendum No. 3            | <input type="checkbox"/> Addendum No. 8  |
| <input type="checkbox"/> Addendum No. 4            | <input type="checkbox"/> Addendum No. 9  |
| <input type="checkbox"/> Addendum No. 5            | <input type="checkbox"/> Addendum No. 10 |

I understand that failure to confirm the receipt of addenda may be cause for rejection of this bid. I further understand that any verbal representation made or assumed to be made during any oral discussion held between Vendor's representatives and any state personnel is not binding. Only the information issued in writing and added to the specifications by an official addendum is binding.

C. I. Walker Machinery Co.  
Company

[Signature]  
Authorized Signature

9/11/17  
Date

**NOTE:** This addendum acknowledgement should be submitted with the bid to expedite document processing.

Revised 6/8/2012

## INSTRUCTIONS TO VENDORS SUBMITTING BIDS

**1. REVIEW DOCUMENTS THOROUGHLY:** The attached documents contain a solicitation for bids. Please read these instructions and all documents attached in their entirety. These instructions provide critical information about requirements that if overlooked could lead to disqualification of a Vendor's bid. All bids must be submitted in accordance with the provisions contained in these instructions and the Solicitation. Failure to do so may result in disqualification of Vendor's bid.

**2. MANDATORY TERMS:** The Solicitation may contain mandatory provisions identified by the use of the words "must," "will," and "shall." Failure to comply with a mandatory term in the Solicitation will result in bid disqualification.

**3. PREBID MEETING:** The item identified below shall apply to this Solicitation.

A pre-bid meeting will not be held prior to bid opening

A **NON-MANDATORY PRE-BID** meeting will be held at the following place and time:

A **MANDATORY PRE-BID** meeting will be held at the following place and time:

All Vendors submitting a bid must attend the mandatory pre-bid meeting. Failure to attend the mandatory pre-bid meeting shall result in disqualification of the Vendor's bid. No one person attending the pre-bid meeting may represent more than one Vendor.

An attendance sheet provided at the pre-bid meeting shall serve as the official document verifying attendance. The State will not accept any other form of proof or documentation to verify attendance. Any person attending the pre-bid meeting on behalf of a Vendor must list on the attendance sheet his or her name and the name of the Vendor he or she is representing.

Additionally, the person attending the pre-bid meeting should include the Vendor's E-Mail address, phone number, and Fax number on the attendance sheet. It is the Vendor's responsibility to locate the attendance sheet and provide the required information. Failure to complete the attendance sheet as required may result in disqualification of Vendor's bid.

All Vendors should arrive prior to the starting time for the pre-bid. Vendors who arrive after the starting time but prior to the end of the pre-bid will be permitted to sign in, but are charged with knowing all matters discussed at the pre-bid.

Questions submitted at least five business days prior to a scheduled pre-bid will be discussed at the pre-bid meeting if possible. Any discussions or answers to questions at the pre-bid meeting are preliminary in nature and are non-binding. Official and binding answers to questions will be published in a written addendum to the Solicitation prior to bid opening.

**4. VENDOR QUESTION DEADLINE:** Vendors may submit questions relating to this Solicitation to the Purchasing Division. Questions must be submitted in writing. All questions must be submitted on or before the date listed below and to the address listed below in order to be considered. A written response will be published in a Solicitation addendum if a response is possible and appropriate. Non-written discussions, conversations, or questions and answers regarding this Solicitation are preliminary in nature and are nonbinding.

Submitted e-mails should have solicitation number in the subject line.

Question Submission Deadline: August 28, 2017 @ 9:00 AM EST

Submit Questions to: Brittany Ingraham  
2019 Washington Street, East  
Charleston, WV 25305  
Fax: (304) 558-4115 (Vendors should not use this fax number for bid submission)  
Email: [Brittany.E.Ingraham@wv.gov](mailto:Brittany.E.Ingraham@wv.gov)

**5. VERBAL COMMUNICATION:** Any verbal communication between the Vendor and any State personnel is not binding, including verbal communication at the mandatory pre-bid conference. Only information issued in writing and added to the Solicitation by an official written addendum by the Purchasing Division is binding.

**6. BID SUBMISSION:** All bids must be submitted electronically through wvOASIS or signed and delivered by the Vendor to the Purchasing Division at the address listed below on or before the date and time of the bid opening. Any bid received by the Purchasing Division staff is considered to be in the possession of the Purchasing Division and will not be returned for any reason. The Purchasing Division will not accept bids, modification of bids, or addendum acknowledgment forms via e-mail. Acceptable delivery methods include electronic submission via wvOASIS, hand delivery, delivery by courier, or facsimile.



The bid delivery address is:  
 Department of Administration, Purchasing Division  
 2019 Washington Street East  
 Charleston, WV 25305-0130

A bid that is not submitted electronically through wvOASIS should contain the information listed below on the face of the envelope or the bid may be rejected by the Purchasing Division.:

SEALED BID:  
 BUYER:  
 SOLICITATION NO.:  
 BID OPENING DATE:  
 BID OPENING TIME:  
 FAX NUMBER:

The Purchasing Division may prohibit the submission of bids electronically through wvOASIS at its sole discretion. Such a prohibition will be contained and communicated in the wvOASIS system resulting in the Vendor's inability to submit bids through wvOASIS. Submission of a response to an Expression or Interest or Request for Proposal is not permitted in wvOASIS.

**For Request For Proposal ("RFP") Responses Only:** In the event that Vendor is responding to a request for proposal, the Vendor shall submit one original technical and one original cost proposal plus           N/A           convenience copies of each to the Purchasing Division at the address shown above. Additionally, the Vendor should identify the bid type as either a technical or cost proposal on the face of each bid envelope submitted in response to a request for proposal as follows:

BID TYPE: (This only applies to CRFP)

- Technical  
 Cost

**7. BID OPENING:** Bids submitted in response to this Solicitation will be opened at the location identified below on the date and time listed below. Delivery of a bid after the bid opening date and time will result in bid disqualification. For purposes of this Solicitation, a bid is considered delivered when confirmation of delivery is provided by wvOASIS (in the case of electronic submission) or when the bid is time stamped by the official Purchasing Division time clock (in the case of hand delivery).

Bid Opening Date and Time: September 5, 2017 at 1:30 PM EST

Bid Opening Location: Department of Administration, Purchasing Division  
 2019 Washington Street East  
 Charleston, WV 25305-0130

- 8. ADDENDUM ACKNOWLEDGEMENT:** Changes or revisions to this Solicitation will be made by an official written addendum issued by the Purchasing Division. Vendor should acknowledge receipt of all addenda issued with this Solicitation by completing an Addendum Acknowledgment Form, a copy of which is included herewith. Failure to acknowledge addenda may result in bid disqualification. The addendum acknowledgement should be submitted with the bid to expedite document processing.
- 9. BID FORMATTING:** Vendor should type or electronically enter the information onto its bid to prevent errors in the evaluation. Failure to type or electronically enter the information may result in bid disqualification.
- 10. ALTERNATES:** Any model, brand, or specification listed in this Solicitation establishes the acceptable level of quality only and is not intended to reflect a preference for, or in any way favor, a particular brand or vendor. Vendors may bid alternates to a listed model or brand provided that the alternate is at least equal to the model or brand and complies with the required specifications. The equality of any alternate being bid shall be determined by the State at its sole discretion. Any Vendor bidding an alternate model or brand should clearly identify the alternate items in its bid and should include manufacturer's specifications, industry literature, and/or any other relevant documentation demonstrating the equality of the alternate items. Failure to provide information for alternate items may be grounds for rejection of a Vendor's bid.
- 11. EXCEPTIONS AND CLARIFICATIONS:** The Solicitation contains the specifications that shall form the basis of a contractual agreement. Vendor shall clearly mark any exceptions, clarifications, or other proposed modifications in its bid. Exceptions to, clarifications of, or modifications of a requirement or term and condition of the Solicitation may result in bid disqualification.
- 12. COMMUNICATION LIMITATIONS:** In accordance with West Virginia Code of State Rules §148-1-6.6, communication with the State of West Virginia or any of its employees regarding this Solicitation during the solicitation, bid, evaluation or award periods, except through the Purchasing Division, is strictly prohibited without prior Purchasing Division approval. Purchasing Division approval for such communication is implied for all agency delegated and exempt purchases.
- 13. REGISTRATION:** Prior to Contract award, the apparent successful Vendor must be properly registered with the West Virginia Purchasing Division and must have paid the \$125 fee, if applicable.
- 14. UNIT PRICE:** Unit prices shall prevail in cases of a discrepancy in the Vendor's bid.
- 15. PREFERENCE:** Vendor Preference may only be granted upon written request and only in accordance with the West Virginia Code § 5A-3-37 and the West Virginia Code of State Rules. A Vendor Preference Certificate form has been attached hereto to allow Vendor to apply for the preference. Vendor's failure to submit the Vendor Preference Certificate form with its bid will result in denial of Vendor Preference. Vendor Preference does not apply to construction projects.

- 16. SMALL, WOMEN-OWNED, OR MINORITY-OWNED BUSINESSES:** For any solicitations publicly advertised for bid, in accordance with West Virginia Code §5A-3-37(a)(7) and W. Va. CSR § 148-22-9, any non-resident vendor certified as a small, women-owned, or minority-owned business under W. Va. CSR § 148-22-9 shall be provided the same preference made available to any resident vendor. Any non-resident small, women-owned, or minority-owned business must identify itself as such in writing, must submit that writing to the Purchasing Division with its bid, and must be properly certified under W. Va. CSR § 148-22-9 prior to contract award to receive the preferences made available to resident vendors. Preference for a non-resident small, women-owned, or minority owned business shall be applied in accordance with W. Va. CSR § 148-22-9.
- 17. WAIVER OF MINOR IRREGULARITIES:** The Director reserves the right to waive minor irregularities in bids or specifications in accordance with West Virginia Code of State Rules § 148-1-4.6.
- 18. ELECTRONIC FILE ACCESS RESTRICTIONS:** Vendor must ensure that its submission in wvOASIS can be accessed and viewed by the Purchasing Division staff immediately upon bid opening. The Purchasing Division will consider any file that cannot be immediately accessed and viewed at the time of the bid opening (such as, encrypted files, password protected files, or incompatible files) to be blank or incomplete as context requires, and are therefore unacceptable. A vendor will not be permitted to unencrypt files, remove password protections, or resubmit documents after bid opening to make a file viewable if those documents are required with the bid. A Vendor may be required to provide document passwords or remove access restrictions to allow the Purchasing Division to print or electronically save documents provided that those documents are viewable by the Purchasing Division prior to obtaining the password or removing the access restriction.
- 19. NON-RESPONSIBLE:** The Purchasing Division Director reserves the right to reject the bid of any vendor as Non-Responsible in accordance with W. Va. Code of State Rules § 148-1-5.3, when the Director determines that the vendor submitting the bid does not have the capability to fully perform, or lacks the integrity and reliability to assure good-faith performance.”
- 20. ACCEPTANCE/REJECTION:** The State may accept or reject any bid in whole, or in part in accordance with W. Va. Code of State Rules § 148-1-4.5. and § 148-1-6.4.b.”

**21. YOUR SUBMISSION IS A PUBLIC DOCUMENT:** Vendor's entire response to the Solicitation and the resulting Contract are public documents. As public documents, they will be disclosed to the public following the bid/proposal opening or award of the contract, as required by the competitive bidding laws of West Virginia Code §§ 5A-3-1 et seq., 5-22-1 et seq., and 5G-1-1 et seq. and the Freedom of Information Act West Virginia Code §§ 29B-1-1 et seq.

**DO NOT SUBMIT MATERIAL YOU CONSIDER TO BE CONFIDENTIAL, A TRADE SECRET, OR OTHERWISE NOT SUBJECT TO PUBLIC DISCLOSURE.**

Submission of any bid, proposal, or other document to the Purchasing Division constitutes your explicit consent to the subsequent public disclosure of the bid, proposal, or document. The Purchasing Division will disclose any document labeled "confidential," "proprietary," "trade secret," "private," or labeled with any other claim against public disclosure of the documents, to include any "trade secrets" as defined by West Virginia Code § 47-22-1 et seq. All submissions are subject to public disclosure without notice.

**22. INTERESTED PARTY DISCLOSURE:** W. Va. Code § 6D-1-2 requires that for contracts with an actual or estimated value of at least \$100,000, the vendor must submit to the Purchasing Division a disclosure of interested parties to the contract, prior to contract award. That disclosure must occur on the form prescribed and approved by the WV Ethics Commission. A copy of that form is included with this solicitation or can be obtained from the WV Ethics Commission. "Interested parties" means: (1) A business entity performing work or service pursuant to, or in furtherance of, the applicable contract, including specifically sub-contractors; (2) the person(s) who have an ownership interest equal to or greater than 25% in the business entity performing work or service pursuant to, or in furtherance of, the applicable contract; and (3) the person or business entity, if any, that served as a compensated broker or intermediary to actively facilitate the applicable contract or negotiated the terms of the applicable contract with the state agency: Provided, That subdivision (2) shall be inapplicable if a business entity is a publicly traded company: Provided, however, That subdivision (3) shall not include persons or business entities performing legal services related to the negotiation or drafting of the applicable contract.

## GENERAL TERMS AND CONDITIONS:

- 1. CONTRACTUAL AGREEMENT:** Issuance of a Award Document signed by the Purchasing Division Director, or his designee, and approved as to form by the Attorney General's office constitutes acceptance of this Contract made by and between the State of West Virginia and the Vendor. Vendor's signature on its bid signifies Vendor's agreement to be bound by and accept the terms and conditions contained in this Contract.
- 2. DEFINITIONS:** As used in this Solicitation/Contract, the following terms shall have the meanings attributed to them below. Additional definitions may be found in the specifications included with this Solicitation/Contract.
  - 2.1. "Agency" or "Agencies"** means the agency, board, commission, or other entity of the State of West Virginia that is identified on the first page of the Solicitation or any other public entity seeking to procure goods or services under this Contract.
  - 2.2. "Bid" or "Proposal"** means the vendors submitted response to this solicitation.
  - 2.3. "Contract"** means the binding agreement that is entered into between the State and the Vendor to provide the goods or services requested in the Solicitation.
  - 2.4. "Director"** means the Director of the West Virginia Department of Administration, Purchasing Division.
  - 2.5. "Purchasing Division"** means the West Virginia Department of Administration, Purchasing Division.
  - 2.6. "Award Document"** means the document signed by the Agency and the Purchasing Division, and approved as to form by the Attorney General, that identifies the Vendor as the contract holder.
  - 2.7. "Solicitation"** means the official notice of an opportunity to supply the State with goods or services that is published by the Purchasing Division.
  - 2.8. "State"** means the State of West Virginia and/or any of its agencies, commissions, boards, etc. as context requires.
  - 2.9. "Vendor" or "Vendors"** means any entity submitting a bid in response to the Solicitation, the entity that has been selected as the lowest responsible bidder, or the entity that has been awarded the Contract as context requires.

**3. CONTRACT TERM; RENEWAL; EXTENSION:** The term of this Contract shall be determined in accordance with the category that has been identified as applicable to this Contract below:

**Term Contract**

**Initial Contract Term:** This Contract becomes effective on \_\_\_\_\_ and extends for a period of \_\_\_\_\_ year(s).

**Renewal Term:** This Contract may be renewed upon the mutual written consent of the Agency, and the Vendor, with approval of the Purchasing Division and the Attorney General's office (Attorney General approval is as to form only). Any request for renewal should be submitted to the Purchasing Division thirty (30) days prior to the expiration date of the initial contract term or appropriate renewal term. A Contract renewal shall be in accordance with the terms and conditions of the original contract. Renewal of this Contract is limited to \_\_\_\_\_ successive one (1) year periods or multiple renewal periods of less than one year, provided that the multiple renewal periods do not exceed \_\_\_\_\_ months in total. Automatic renewal of this Contract is prohibited. Notwithstanding the foregoing, Purchasing Division approval is not required on agency delegated or exempt purchases. Attorney General approval may be required for vendor terms and conditions.

**Delivery Order Limitations:** In the event that this contract permits delivery orders, a delivery order may only be issued during the time this Contract is in effect. Any delivery order issued within one year of the expiration of this Contract shall be effective for one year from the date the delivery order is issued. No delivery order may be extended beyond one year after this Contract has expired.

**Fixed Period Contract:** This Contract becomes effective upon Vendor's receipt of the notice to proceed and must be completed within \_\_\_\_\_ days.

**Fixed Period Contract with Renewals:** This Contract becomes effective upon Vendor's receipt of the notice to proceed and part of the Contract more fully described in the attached specifications must be completed within \_\_\_\_\_ days.

Upon completion, the vendor agrees that maintenance, monitoring, or warranty services will be provided for one year thereafter with an additional \_\_\_\_\_ successive one year renewal periods or multiple renewal periods of less than one year provided that the multiple renewal periods do not exceed \_\_\_\_\_ months in total. Automatic renewal of this Contract is prohibited.

**One Time Purchase:** The term of this Contract shall run from the issuance of the Award Document until all of the goods contracted for have been delivered, but in no event will this Contract extend for more than one fiscal year.

**Other:** See attached.

**4. NOTICE TO PROCEED:** Vendor shall begin performance of this Contract immediately upon receiving notice to proceed unless otherwise instructed by the Agency. Unless otherwise specified, the fully executed Award Document will be considered notice to proceed.

**5. QUANTITIES:** The quantities required under this Contract shall be determined in accordance with the category that has been identified as applicable to this Contract below.

**Open End Contract:** Quantities listed in this Solicitation are approximations only, based on estimates supplied by the Agency. It is understood and agreed that the Contract shall cover the quantities actually ordered for delivery during the term of the Contract, whether more or less than the quantities shown.

**Service:** The scope of the service to be provided will be more clearly defined in the specifications included herewith.

**Combined Service and Goods:** The scope of the service and deliverable goods to be provided will be more clearly defined in the specifications included herewith.

**One Time Purchase:** This Contract is for the purchase of a set quantity of goods that are identified in the specifications included herewith. Once those items have been delivered, no additional goods may be procured under this Contract without an appropriate change order approved by the Vendor, Agency, Purchasing Division, and Attorney General's office.

**6. EMERGENCY PURCHASES:** The Purchasing Division Director may authorize the Agency to purchase goods or services in the open market that Vendor would otherwise provide under this Contract if those goods or services are for immediate or expedited delivery in an emergency. Emergencies shall include, but are not limited to, delays in transportation or an unanticipated increase in the volume of work. An emergency purchase in the open market, approved by the Purchasing Division Director, shall not constitute breach of this Contract and shall not entitle the Vendor to any form of compensation or damages. This provision does not excuse the State from fulfilling its obligations under a One Time Purchase contract.

**7. REQUIRED DOCUMENTS:** All of the items checked below must be provided to the Purchasing Division by the Vendor as specified below.

**BID BOND (Construction Only):** Pursuant to the requirements contained in W. Va. Code § 5-22-1(c), All Vendors submitting a bid on a construction project shall furnish a valid bid bond in the amount of five percent (5%) of the total amount of the bid protecting the State of West Virginia. The bid bond must be submitted with the bid.

**PERFORMANCE BOND:** The apparent successful Vendor shall provide a performance bond in the amount of \_\_\_\_\_. The performance bond must be received by the Purchasing Division prior to Contract award. On construction contracts, the performance bond must be 100% of the Contract value.

**LABOR/MATERIAL PAYMENT BOND:** The apparent successful Vendor shall provide a labor/material payment bond in the amount of 100% of the Contract value. The labor/material payment bond must be delivered to the Purchasing Division prior to Contract award.

In lieu of the Bid Bond, Performance Bond, and Labor/Material Payment Bond, the Vendor may provide certified checks, cashier's checks, or irrevocable letters of credit. Any certified check, cashier's check, or irrevocable letter of credit provided in lieu of a bond must be of the same amount and delivered on the same schedule as the bond it replaces. A letter of credit submitted in lieu of a performance and labor/material payment bond will only be allowed for projects under \$100,000. Personal or business checks are not acceptable. Notwithstanding the foregoing, West Virginia Code § 5-22-1 (d) mandates that a vendor provide a performance and labor/material payment bond for construction projects. Accordingly, substitutions for the performance and labor/material payment bonds for construction projects is not permitted.

**MAINTENANCE BOND:** The apparent successful Vendor shall provide a two (2) year maintenance bond covering the roofing system. The maintenance bond must be issued and delivered to the Purchasing Division prior to Contract award.

**LICENSE(S) / CERTIFICATIONS / PERMITS:** In addition to anything required under the Section entitled Licensing, of the General Terms and Conditions, the apparent successful Vendor shall furnish proof of the following licenses, certifications, and/or permits prior to Contract award, in a form acceptable to the Purchasing Division.

The apparent successful Vendor shall also furnish proof of any additional licenses or certifications contained in the specifications prior to Contract award regardless of whether or not that requirement is listed above.



**8. INSURANCE:** The apparent successful Vendor shall furnish proof of the insurance identified by a checkmark below prior to Contract award. Subsequent to contract award, and prior to the insurance expiration date, Vendor shall provide the Agency with proof that the insurance mandated herein has been continued. Vendor must also provide Agency with immediate notice of any changes in its insurance policies mandated herein, including but not limited to, policy cancelation, policy reduction, or change in insurers. The insurance coverages identified below must be maintained throughout the life of this contract. The apparent successful Vendor shall also furnish proof of any additional insurance requirements contained in the specifications prior to Contract award regardless of whether or not that insurance requirement is listed in this section.

Vendor must maintain:

**Commercial General Liability Insurance** in at least an amount of:

\_\_\_\_\_

**Automobile Liability Insurance** in at least an amount of: \_\_\_\_\_

**Professional/Malpractice/Errors and Omission Insurance** in at least an amount of:

\_\_\_\_\_

**Commercial Crime and Third Party Fidelity Insurance** in an amount of:

\_\_\_\_\_

**Cyber Liability Insurance** in an amount of: \_\_\_\_\_

**Builders Risk Insurance** in an amount equal to 100% of the amount of the Contract.

**9. WORKERS' COMPENSATION INSURANCE:** The apparent successful Vendor shall comply with laws relating to workers compensation, shall maintain workers' compensation insurance when required, and shall furnish proof of workers' compensation insurance upon request.

**10. LITIGATION BOND:** The Director reserves the right to require any Vendor that files a protest of an award to submit a litigation bond in the amount equal to one percent of the lowest bid submitted or \$5,000, whichever is greater. The entire amount of the bond shall be forfeited if the hearing officer determines that the protest was filed for frivolous or improper purpose, including but not limited to, the purpose of harassing, causing unnecessary delay, or needless expense for the Agency. All litigation bonds shall be made payable to the Purchasing Division. In lieu of a bond, the protester may submit a cashier's check or certified check payable to the Purchasing Division. Cashier's or certified checks will be deposited with and held by the State Treasurer's office. If it is determined that the protest has not been filed for frivolous or improper purpose, the bond or deposit shall be returned in its entirety.

**11. LIQUIDATED DAMAGES:** Vendor shall pay liquidated damages in the amount of

for \_\_\_\_\_

This clause shall in no way be considered exclusive and shall not limit the State or Agency's right to pursue any other available remedy.

**12. ACCEPTANCE:** Vendor's signature on its bid, or on the certification and signature page, constitutes an offer to the State that cannot be unilaterally withdrawn, signifies that the product or service proposed by vendor meets the mandatory requirements contained in the Solicitation for that product or service, unless otherwise indicated, and signifies acceptance of the terms and conditions contained in the Solicitation unless otherwise indicated.

**13. PRICING:** The pricing set forth herein is firm for the life of the Contract, unless specified elsewhere within this Solicitation/Contract by the State. A Vendor's inclusion of price adjustment provisions in its bid, without an express authorization from the State in the Solicitation to do so, may result in bid disqualification.

**14. PAYMENT:** Payment in advance is prohibited under this Contract. Payment may only be made after the delivery and acceptance of goods or services. The Vendor shall submit invoices, in arrears.

**15. PURCHASING CARD ACCEPTANCE:** The State of West Virginia currently utilizes a Purchasing Card program, administered under contract by a banking institution, to process payment for goods and services. The Vendor must accept the State of West Virginia's Purchasing Card for payment of all orders under this Contract unless the box below is checked.

Vendor is not required to accept the State of West Virginia's Purchasing Card as payment for all goods and services.

- 16. TAXES:** The Vendor shall pay any applicable sales, use, personal property or any other taxes arising out of this Contract and the transactions contemplated thereby. The State of West Virginia is exempt from federal and state taxes and will not pay or reimburse such taxes.
- 17. ADDITIONAL FEES:** Vendor is not permitted to charge additional fees or assess additional charges that were not either expressly provided for in the solicitation published by the State of West Virginia or included in the unit price or lump sum bid amount that Vendor is required by the solicitation to provide. Including such fees or charges as notes to the solicitation may result in rejection of vendor's bid. Requesting such fees or charges be paid after the contract has been awarded may result in cancellation of the contract.
- 18. FUNDING:** This Contract shall continue for the term stated herein, contingent upon funds being appropriated by the Legislature or otherwise being made available. In the event funds are not appropriated or otherwise made available, this Contract becomes void and of no effect beginning on July 1 of the fiscal year for which funding has not been appropriated or otherwise made available.
- 19. CANCELLATION:** The Purchasing Division Director reserves the right to cancel this Contract immediately upon written notice to the vendor if the materials or workmanship supplied do not conform to the specifications contained in the Contract. The Purchasing Division Director may also cancel any purchase or Contract upon 30 days written notice to the Vendor in accordance with West Virginia Code of State Rules § 148-1-6.1.e.
- 20. TIME:** Time is of the essence with regard to all matters of time and performance in this Contract.
- 21. APPLICABLE LAW:** This Contract is governed by and interpreted under West Virginia law without giving effect to its choice of law principles. Any information provided in specification manuals, or any other source, verbal or written, which contradicts or violates the West Virginia Constitution, West Virginia Code or West Virginia Code of State Rules is void and of no effect.
- 22. COMPLIANCE WITH LAWS:** Vendor shall comply with all applicable federal, state, and local laws, regulations and ordinances. By submitting a bid, Vendor acknowledges that it has reviewed, understands, and will comply with all applicable laws, regulations, and ordinances.
- 23. ARBITRATION:** Any references made to arbitration contained in this Contract, Vendor's bid, or in any American Institute of Architects documents pertaining to this Contract are hereby deleted, void, and of no effect.

- 24. MODIFICATIONS:** This writing is the parties' final expression of intent. Notwithstanding anything contained in this Contract to the contrary no modification of this Contract shall be binding without mutual written consent of the Agency, and the Vendor, with approval of the Purchasing Division and the Attorney General's office (Attorney General approval is as to form only). Any change to existing contracts that adds work or changes contract cost, and were not included in the original contract, must be approved by the Purchasing Division and the Attorney General's Office (as to form) prior to the implementation of the change or commencement of work affected by the change.
- 25. WAIVER:** The failure of either party to insist upon a strict performance of any of the terms or provision of this Contract, or to exercise any option, right, or remedy herein contained, shall not be construed as a waiver or a relinquishment for the future of such term, provision, option, right, or remedy, but the same shall continue in full force and effect. Any waiver must be expressly stated in writing and signed by the waiving party.
- 26. SUBSEQUENT FORMS:** The terms and conditions contained in this Contract shall supersede any and all subsequent terms and conditions which may appear on any form documents submitted by Vendor to the Agency or Purchasing Division such as price lists, order forms, invoices, sales agreements, or maintenance agreements, and includes internet websites or other electronic documents. Acceptance or use of Vendor's forms does not constitute acceptance of the terms and conditions contained thereon.
- 27. ASSIGNMENT:** Neither this Contract nor any monies due, or to become due hereunder, may be assigned by the Vendor without the express written consent of the Agency, the Purchasing Division, the Attorney General's office (as to form only), and any other government agency or office that may be required to approve such assignments. Notwithstanding the foregoing, Purchasing Division approval may or may not be required on certain agency delegated or exempt purchases.
- 28. WARRANTY:** The Vendor expressly warrants that the goods and/or services covered by this Contract will: (a) conform to the specifications, drawings, samples, or other description furnished or specified by the Agency; (b) be merchantable and fit for the purpose intended; and (c) be free from defect in material and workmanship.
- 29. STATE EMPLOYEES:** State employees are not permitted to utilize this Contract for personal use and the Vendor is prohibited from permitting or facilitating the same.
- 30. BANKRUPTCY:** In the event the Vendor files for bankruptcy protection, the State of West Virginia may deem this Contract null and void, and terminate this Contract without notice.
- 31. PRIVACY, SECURITY, AND CONFIDENTIALITY:** The Vendor agrees that it will not disclose to anyone, directly or indirectly, any such personally identifiable information or other confidential information gained from the Agency, unless the individual who is the subject of the information consents to the disclosure in writing or the disclosure is made pursuant to the Agency's policies, procedures, and rules. Vendor further agrees to comply with the Confidentiality Policies and Information Security Accountability Requirements, set forth in <http://www.state.wv.us/admin/purchase/privacy/default.html>.

**32. YOUR SUBMISSION IS A PUBLIC DOCUMENT:** Vendor's entire response to the Solicitation and the resulting Contract are public documents. As public documents, they will be disclosed to the public following the bid/proposal opening or award of the contract, as required by the competitive bidding laws of West Virginia Code §§ 5A-3-1 et seq., 5-22-1 et seq., and 5G-1-1 et seq. and the Freedom of Information Act West Virginia Code §§ 29B-1-1 et seq.

**DO NOT SUBMIT MATERIAL YOU CONSIDER TO BE CONFIDENTIAL, A TRADE SECRET, OR OTHERWISE NOT SUBJECT TO PUBLIC DISCLOSURE.**

Submission of any bid, proposal, or other document to the Purchasing Division constitutes your explicit consent to the subsequent public disclosure of the bid, proposal, or document. The Purchasing Division will disclose any document labeled "confidential," "proprietary," "trade secret," "private," or labeled with any other claim against public disclosure of the documents, to include any "trade secrets" as defined by West Virginia Code § 47-22-1 et seq. All submissions are subject to public disclosure without notice.

**33. LICENSING:** In accordance with West Virginia Code of State Rules § 148-1-6.1.e, Vendor must be licensed and in good standing in accordance with any and all state and local laws and requirements by any state or local agency of West Virginia, including, but not limited to, the West Virginia Secretary of State's Office, the West Virginia Tax Department, West Virginia Insurance Commission, or any other state agency or political subdivision. Upon request, the Vendor must provide all necessary releases to obtain information to enable the Purchasing Division Director or the Agency to verify that the Vendor is licensed and in good standing with the above entities.

**34. ANTITRUST:** In submitting a bid to, signing a contract with, or accepting a Award Document from any agency of the State of West Virginia, the Vendor agrees to convey, sell, assign, or transfer to the State of West Virginia all rights, title, and interest in and to all causes of action it may now or hereafter acquire under the antitrust laws of the United States and the State of West Virginia for price fixing and/or unreasonable restraints of trade relating to the particular commodities or services purchased or acquired by the State of West Virginia. Such assignment shall be made and become effective at the time the purchasing agency tenders the initial payment to Vendor.

**35. VENDOR CERTIFICATIONS:** By signing its bid or entering into this Contract, Vendor certifies (1) that its bid or offer was made without prior understanding, agreement, or connection with any corporation, firm, limited liability company, partnership, person or entity submitting a bid or offer for the same material, supplies, equipment or services; (2) that its bid or offer is in all respects fair and without collusion or fraud; (3) that this Contract is accepted or entered into without any prior understanding, agreement, or connection to any other entity that could be considered a violation of law; and (4) that it has reviewed this Solicitation in its entirety; understands the requirements, terms and conditions, and other information contained herein.

Vendor's signature on its bid or offer also affirms that neither it nor its representatives have any interest, nor shall acquire any interest, direct or indirect, which would compromise the performance of its services hereunder. Any such interests shall be promptly presented in detail to the Agency. The individual signing this bid or offer on behalf of Vendor certifies that he or she is authorized by the Vendor to execute this bid or offer or any documents related thereto on Vendor's behalf; that he or she is authorized to bind the Vendor in a contractual relationship; and that, to the best of his or her knowledge, the Vendor has properly registered with any State agency that may require registration.

**36. VENDOR RELATIONSHIP:** The relationship of the Vendor to the State shall be that of an independent contractor and no principal-agent relationship or employer-employee relationship is contemplated or created by this Contract. The Vendor as an independent contractor is solely liable for the acts and omissions of its employees and agents. Vendor shall be responsible for selecting, supervising, and compensating any and all individuals employed pursuant to the terms of this Solicitation and resulting contract. Neither the Vendor, nor any employees or subcontractors of the Vendor, shall be deemed to be employees of the State for any purpose whatsoever. Vendor shall be exclusively responsible for payment of employees and contractors for all wages and salaries, taxes, withholding payments, penalties, fees, fringe benefits, professional liability insurance premiums, contributions to insurance and pension, or other deferred compensation plans, including but not limited to, Workers' Compensation and Social Security obligations, licensing fees, etc. and the filing of all necessary documents, forms, and returns pertinent to all of the foregoing.

Vendor shall hold harmless the State, and shall provide the State and Agency with a defense against any and all claims including, but not limited to, the foregoing payments, withholdings, contributions, taxes, Social Security taxes, and employer income tax returns.

**37. INDEMNIFICATION:** The Vendor agrees to indemnify, defend, and hold harmless the State and the Agency, their officers, and employees from and against: (1) Any claims or losses for services rendered by any subcontractor, person, or firm performing or supplying services, materials, or supplies in connection with the performance of the Contract; (2) Any claims or losses resulting to any person or entity injured or damaged by the Vendor, its officers, employees, or subcontractors by the publication, translation, reproduction, delivery, performance, use, or disposition of any data used under the Contract in a manner not authorized by the Contract, or by Federal or State statutes or regulations; and (3) Any failure of the Vendor, its officers, employees, or subcontractors to observe State and Federal laws including, but not limited to, labor and wage and hour laws.

**38. PURCHASING AFFIDAVIT:** In accordance with West Virginia Code § 5-22-1(i), the contracting public entity shall not award a contract for a construction project to any bidder that is known to be in default on any monetary obligation owed to the state or a political subdivision of the state, including, but not limited to, obligations related to payroll taxes, property taxes, sales and use taxes, fire service fees, or other fines or fees. Accordingly, prior to contract award, Vendors are required to sign, notarize, and submit the Purchasing Affidavit to the Purchasing Division affirming under oath that it is not in default on any monetary obligation owed to the state or a political subdivision of the state.

**39. ADDITIONAL AGENCY AND LOCAL GOVERNMENT USE:** This Contract may be utilized by other agencies, spending units, and political subdivisions of the State of West Virginia; county, municipal, and other local government bodies; and school districts ("Other Government Entities"). Any extension of this Contract to the aforementioned Other Government Entities must be on the same prices, terms, and conditions as those offered and agreed to in this Contract, provided that such extension is in compliance with the applicable laws, rules, and ordinances of the Other Government Entity. If the Vendor does not wish to extend the prices, terms, and conditions of its bid and subsequent contract to the Other Government Entities, the Vendor must clearly indicate such refusal in its bid. A refusal to extend this Contract to the Other Government Entities shall not impact or influence the award of this Contract in any manner.

**40. CONFLICT OF INTEREST:** Vendor, its officers or members or employees, shall not presently have or acquire an interest, direct or indirect, which would conflict with or compromise the performance of its obligations hereunder. Vendor shall periodically inquire of its officers, members and employees to ensure that a conflict of interest does not arise. Any conflict of interest discovered shall be promptly presented in detail to the Agency.

**41. REPORTS:** Vendor shall provide the Agency and/or the Purchasing Division with the following reports identified by a checked box below:

Such reports as the Agency and/or the Purchasing Division may request. Requested reports may include, but are not limited to, quantities purchased, agencies utilizing the contract, total contract expenditures by agency, etc.

Quarterly reports detailing the total quantity of purchases in units and dollars, along with a listing of purchases by agency. Quarterly reports should be delivered to the Purchasing Division via email at [purchasing.requisitions@wv.gov](mailto:purchasing.requisitions@wv.gov).

**42. BACKGROUND CHECK:** In accordance with W. Va. Code § 15-2D-3, the Director of the Division of Protective Services shall require any service provider whose employees are regularly employed on the grounds or in the buildings of the Capitol complex or who have access to sensitive or critical information to submit to a fingerprint-based state and federal background inquiry through the state repository. The service provider is responsible for any costs associated with the fingerprint-based state and federal background inquiry.

After the contract for such services has been approved, but before any such employees are permitted to be on the grounds or in the buildings of the Capitol complex or have access to sensitive or critical information, the service provider shall submit a list of all persons who will be physically present and working at the Capitol complex to the Director of the Division of Protective Services for purposes of verifying compliance with this provision. The State reserves the right to prohibit a service provider's employees from accessing sensitive or critical information or to be present at the Capitol complex based upon results addressed from a criminal background check.

Service providers should contact the West Virginia Division of Protective Services by phone at (304) 558-9911 for more information.

**43. PREFERENCE FOR USE OF DOMESTIC STEEL PRODUCTS:** Except when authorized by the Director of the Purchasing Division pursuant to W. Va. Code § 5A-3-56, no contractor may use or supply steel products for a State Contract Project other than those steel products made in the United States. A contractor who uses steel products in violation of this section may be subject to civil penalties pursuant to W. Va. Code § 5A-3-56. As used in this section:

- a. "State Contract Project" means any erection or construction of, or any addition to, alteration of or other improvement to any building or structure, including, but not limited to, roads or highways, or the installation of any heating or cooling or ventilating plants or other equipment, or the supply of and materials for such projects, pursuant to a contract with the State of West Virginia for which bids were solicited on or after June 6, 2001.
- b. "Steel Products" means products rolled, formed, shaped, drawn, extruded, forged, cast, fabricated or otherwise similarly processed, or processed by a combination of two or more or such operations, from steel made by the open heath, basic oxygen, electric furnace, Bessemer or other steel making process. The Purchasing Division Director may, in writing, authorize the use of foreign steel products if:
  - c. The cost for each contract item used does not exceed one tenth of one percent (.1%) of the total contract cost or two thousand five hundred dollars (\$2,500.00), whichever is greater. For the purposes of this section, the cost is the value of the steel product as delivered to the project; or
  - d. The Director of the Purchasing Division determines that specified steel materials are not produced in the United States in sufficient quantity or otherwise are not reasonably available to meet contract requirements.



**44. PREFERENCE FOR USE OF DOMESTIC ALUMINUM, GLASS, AND STEEL:** In Accordance with W. Va. Code § 5-19-1 et seq., and W. Va. CSR § 148-10-1 et seq., for every contract or subcontract, subject to the limitations contained herein, for the construction, reconstruction, alteration, repair, improvement or maintenance of public works or for the purchase of any item of machinery or equipment to be used at sites of public works, only domestic aluminum, glass or steel products shall be supplied unless the spending officer determines, in writing, after the receipt of offers or bids, (1) that the cost of domestic aluminum, glass or steel products is unreasonable or inconsistent with the public interest of the State of West Virginia, (2) that domestic aluminum, glass or steel products are not produced in sufficient quantities to meet the contract requirements, or (3) the available domestic aluminum, glass, or steel do not meet the contract specifications. This provision only applies to public works contracts awarded in an amount more than fifty thousand dollars (\$50,000) or public works contracts that require more than ten thousand pounds of steel products.

The cost of domestic aluminum, glass, or steel products may be unreasonable if the cost is more than twenty percent (20%) of the bid or offered price for foreign made aluminum, glass, or steel products. If the domestic aluminum, glass or steel products to be supplied or produced in a "substantial labor surplus area", as defined by the United States Department of Labor, the cost of domestic aluminum, glass, or steel products may be unreasonable if the cost is more than thirty percent (30%) of the bid or offered price for foreign made aluminum, glass, or steel products. This preference shall be applied to an item of machinery or equipment, as indicated above, when the item is a single unit of equipment or machinery manufactured primarily of aluminum, glass or steel, is part of a public works contract and has the sole purpose or of being a permanent part of a single public works project. This provision does not apply to equipment or machinery purchased by a spending unit for use by that spending unit and not as part of a single public works project.

All bids and offers including domestic aluminum, glass or steel products that exceed bid or offer prices including foreign aluminum, glass or steel products after application of the preferences provided in this provision may be reduced to a price equal to or lower than the lowest bid or offer price for foreign aluminum, glass or steel products plus the applicable preference. If the reduced bid or offer prices are made in writing and supersede the prior bid or offer prices, all bids or offers, including the reduced bid or offer prices, will be reevaluated in accordance with this rule.

**45. INTERESTED PARTY SUPPLEMENTAL DISCLOSURE:** W. Va. Code § 6D-1-2 requires that for contracts with an actual or estimated value of at least \$100,000, the vendor must submit to the Agency a supplemental disclosure of interested parties reflecting any new or differing interested parties to the contract, which were not included in the original pre-award interested party disclosure, within 30 days following the completion or termination of the contract. A copy of that form is included with this solicitation or can be obtained from the WV Ethics Commission. "Interested parties" means: (1) A business entity performing work or service pursuant to, or in furtherance of, the applicable contract, including specifically sub-contractors; (2) the person(s) who have an ownership interest equal to or greater than 25% in the business entity performing work or service pursuant to, or in furtherance of, the applicable contract; and (3) the person or business entity, if any, that served as a compensated broker or intermediary to actively facilitate the applicable contract or negotiated the terms of the applicable contract with the state agency: Provided, That subdivision (2) shall be inapplicable if a business entity is a publicly traded company: Provided, however, That subdivision (3) shall not include persons or business entities performing legal services related to the negotiation or drafting of the applicable contract. The Agency shall submit a copy of the disclosure to the Ethics Commission within 15 days after receiving the supplemental disclosure of interested parties.

**DESIGNATED CONTACT:** Vendor appoints the individual identified in this Section as the Contract Administrator and the initial point of contact for matters relating to this Contract.

Matthew E. Conner, Sales Representative  
(Name, Title)  
Matthew E. Conner, Sales Representative  
(Printed Name and Title)  
P.O. Box 2427, Charleston, WV 25329  
(Address)  
(304) 543-5406 / (304) 759-6404  
(Phone Number) / (Fax Number)  
mconner@walker-cat.com  
(email address)

**CERTIFICATION AND SIGNATURE:** By signing below, or submitting documentation through wvOASIS, I certify that I have reviewed this Solicitation in its entirety; that I understand the requirements, terms and conditions, and other information contained herein; that this bid, offer or proposal constitutes an offer to the State that cannot be unilaterally withdrawn; that the product or service proposed meets the mandatory requirements contained in the Solicitation for that product or service, unless otherwise stated herein; that the Vendor accepts the terms and conditions contained in the Solicitation, unless otherwise stated herein; that I am submitting this bid, offer or proposal for review and consideration; that I am authorized by the vendor to execute and submit this bid, offer, or proposal, or any documents related thereto on vendor's behalf; that I am authorized to bind the vendor in a contractual relationship; and that to the best of my knowledge, the vendor has properly registered with any State agency that may require registration.

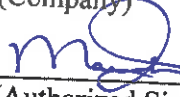
C.I. Walker Machinery Co.  
(Company)  
 Matthew E. Conner, Sales Representative  
(Authorized Signature) (Representative Name, Title)  
Matthew E. Conner, Sales Representative  
(Printed Name and Title of Authorized Representative)  
9/11/17  
(Date)  
(304) 543-5406 / (304) 759-6404  
(Phone Number) (Fax Number)

SPECIFICATIONS

1. **PURPOSE AND SCOPE:** The West Virginia Purchasing Division is soliciting bids on behalf of West Virginia Department of Environmental Protection (Office of Abandoned Mine Lands and Reclamation) to establish a contract for the one-time purchase of a compact excavator with attachments.

Current Operating Environment:

The Agency currently owns a FORD F-350 Crew Cab, Short Bed, Single Rear Wheel, 4x4 (four-wheel drive) pickup with a 14,000-pound towing capacity including a 7'X16' PJ dump bed trailer that will be used for the transportation of the solicited equipment. The compact excavator must be able to be hauled on this equipment.

2. **DEFINITIONS:** The terms listed below shall have the meanings assigned to them below. Additional definitions can be found in section 2 of the General Terms and Conditions.
  - 2.1 **"Contract Item"** means the list of items identified and fully described by the specifications in 3.1 below.
  - 2.2 **"Pricing Page"** means the pages, contained in wvOASIS or attached as Exhibit A, upon which Vendor should list its proposed price for the Contract Items.
  - 2.3 **"Solicitation"** means the official notice of an opportunity to supply the State with goods or services that is published by the Purchasing Division.
  - 2.4 **"F.O.B."** means free on board.
  - 2.5 **"EPA Final Tier 4 Diesel Engine"** means the Environmental Protection Agencies' regulation to control the emissions from new and in-use nonroad compression ignition engines.
  - 2.6 **"OEM"** means the original equipment manufacturer.
  - 2.7 **"ROPS"** means the roll over protection structure.
  - 2.8 **"WVDEP", "AML" AND "AGENCY"** means West Virginia Department of Environmental Protection Office of Abandoned Mine Lands and Reclamation
  - 2.9 **"GRADE 70 TRANSPORT CHAIN"** means heat treated carbon steel transport chain that meets or exceeds regulations set by the Department of Transportation.

**3. GENERAL REQUIREMENTS:**

**3.1 Mandatory Contract Item Requirements:** Contract Item must meet or exceed the mandatory requirements listed below.

**3.1.1 Compact Excavator**

**3.1.1.1** Compact excavator shall be John Deere 35G or Equal.

**3.1.1.2** Unit must be "new" manufactured in 2017 or current model year machine; clearly identified and marked with the date of manufacture.

**3.1.1.3** Unit must be between 8,200 to 8,900-pound transport weight. Transport weight shall include excavator full of fluids, thumb and (Item 3.1.3) a 24" digging bucket.

**3.1.1.4** Overall width shall not exceed 72 inches.

**3.1.1.5** Unit must be equipped with one and two-way switchable auxiliary hydraulics on the stick for attachments. The auxiliary hydraulics shall have standard quick couplers for the attachments. The controls must be joystick mounted in the cab for operation. There shall be a device such as a hydraulic accumulator to release pressure while changing the attachment hydraulic lines. Hydraulic flow rate must be a minimum of 16 gallons per minute.

**3.1.1.6** Unit must be equipped with a hydraulic power angle blade for backfilling. Blade must be operable from the cab.

**3.1.1.7** Unit must be equipped with a hydraulic operating OEM thumb or Manufacturers' suggested adequate size for the machine. The thumb shall have a minimum of two tines.

**3.1.1.8** Unit must be equipped with an enclosed glass cab. The glass shall be tinted laminated safety glass.

**3.1.1.9** The front glass shall be equipped with a powered wiper.

REQUEST FOR QUOTATION  
Compact Excavator with Attachments

---

- 3.1.1.10 Unit cab shall be ROPS certified.
- 3.1.1.11 Unit shall be equipped with manufacturers' heater and air conditioning system.
- 3.1.1.12 Unit shall have AM/FM Radio and Antennae installed in cab.
- 3.1.1.13 Unit must be equipped with a cushioned cloth suspension seat with armrests inside the cab. The seat shall be equipped with a seat belt that meets the federal motor vehicle standards.
- 3.1.1.14 Unit must be equipped with a Werk-Brau HD055-45, or Equal pin grabber type quick coupler.
  - 3.1.1.14.1 The quick coupler must be able to install the bucket on "backwards" so that the bucket opening shall be open away from the machine.
  - 3.1.1.14.2 The quick coupler shall be equipped with dual locks and a lifting eye.
- 3.1.1.15 Manufacturer's vandalism protection package shall be provided. The vandalism protection package shall include locking cab doors, locking compartments for engine and hydraulic components, locking fuel and radiator access and electrical cut-off switch. All locks except master switch shall be keyed alike.
- 3.1.1.16 Unit must have an EPA final tier 4 diesel engine with a minimum of 23 HP. Engine must be equipped with a self-priming fuel system. Engine shall be liquid cooled and coolant shall be manufacturer approved extended life anti-freeze that provides protection to at least -30 degrees Fahrenheit. Cold weather starting aid shall be provided.
- 3.1.1.17 Unit shall be manufacturers standard undercarriage and be fitted with rubber tracks.

**REQUEST FOR QUOTATION**  
**Compact Excavator with Attachments**

---

- 3.1.1.18** Prior to delivery; unit must be fully assembled and serviced in accordance with the manufacturers "Work Ready" preparation procedures.
- 3.1.1.19** Unit shall have a minimum lift capacity of 3,300 pounds at a minimum of 10 feet out and over the blade of the machine.
- 3.1.1.20** Unit shall have a minimum digging reach of 17 feet and minimum digging force of 4,200 lbs.
- 3.1.1.21** Unit shall be equipped with the following lighting systems:
  - 3.1.1.21.1** The unit must have a minimum of two halogen operating lights. One shall be boom mounted and one shall be cab mounted towards the bucket.
  - 3.1.1.21.2** There shall be a roof top mounted beacon light.
  - 3.1.1.21.3** The unit shall have tail lights or reflectors on the rear of the machine.
  - 3.1.1.21.4** All lighting shall be switch operable from the cab.
- 3.1.1.22** Unit shall be fitted with an OEM front window protection screen.
- 3.1.1.23** Unit shall be equipped with a fire extinguisher properly mounted to the machine.
- 3.1.1.24** All parts and accessories advertised and regularly supplied as standard shall be included. All standard safety features, required by Federal and State Law, shall be included.
- 3.1.1.25** Unit shall have at least one of each: owner's manual, repair manual, operator's manual, and the safety maintenance and operation literature in paper or digital format (CD/DVD) at the time of delivery.

REQUEST FOR QUOTATION  
Compact Excavator with Attachments

---

**3.1.1.25** All equipment listed below (3.1.2, 3.1.3, 3.1.4, 3.1.5, 3.1.6, 3.1.7, and 3.1.8) must all be compatible with the Compact Excavator Brand and Model that the vendor is submitting in response to this solicitation.

**3.1.2 12" Digging Bucket**

**3.1.2.1** Digging Bucket must be Vendor's strongest duty with a minimum capacity of 2.0 cubic feet.

**3.1.2.2** Digging bucket must be compatible with the installed quick coupler (pins installed) on the compact excavator (3.1.1.14).

**3.1.2.3** Digging Bucket must have replaceable teeth.

**3.1.2.4** Digging Bucket must be compatible with 3.1.1 Compact Excavator Brand and Model vendor bid for this solicitation.

**3.1.3 24" Digging Bucket**

**3.1.3.1** Digging Bucket must be Vendor's strongest duty with a minimum capacity of 5.0 cubic feet.

**3.1.3.2** Digging bucket must be compatible with the installed quick coupler (pins installed) on the compact excavator (3.1.1.14).

**3.1.3.3** Digging Bucket must have replaceable teeth.

**3.1.3.4** Digging Bucket must be compatible with 3.1.1 Compact Excavator Brand and Model vendor bid for this solicitation.

**3.1.4 36" Grading Bucket**

**3.1.4.1** Grading Bucket must be Werk-Brau WTB36 or Equal.

**3.1.4.2** Grading Bucket must have a minimum of 90 degrees of tilt (45 degrees in each direction).



3.1.4.3 Grading Bucket must have a minimum capacity of three (3) cubic feet.

3.1.4.4 Grading Bucket must be compatible with the installed quick coupler (pins installed) and auxiliary hydraulics on the compact excavator (3.1.1.14).

3.1.4.5 Grading Bucket must have bolt on smooth cutting edge installed.

3.1.4.6 Grading Bucket must have tapered sides to prevent wet material from sticking while dumping.

3.1.4.7 Grading Bucket must be compatible with 3.1.1 Compact Excavator Brand and Model vendor bid for this solicitation.

**3.1.5 Root Rake**

3.1.5.1 Root rake must be Tag Manufacturing 2405R or Equal.

3.1.5.2 Root rake must be minimum of 24" wide.

3.1.5.3 Root rake must have five (5) tines. Each tine must be eight (8) inches in length.

3.1.5.4 Root rake must be compatible with the installed quick coupler (pins installed) on the compact excavator (3.1.1.14).

3.1.5.5 Root Rake must be compatible with 3.1.1 Compact Excavator Brand and Model vendor bid for this solicitation.

**3.1.6 Hydraulic Brush Cutter**

3.1.6.1 Hydraulic brush cutter attachment must be Bushmaster Mini X Model MX401-42SL or Equal

3.1.6.2 Hydraulic brush cutter attachment must be compatible with the installed quick coupler (pins installed) and auxiliary hydraulics on the compact excavator (3.1.1.14).

**3.1.6.3** Hydraulic brush cutter attachment must have a minimum of 42" cutting diameter. Brush cutter must be capable of cutting up to three-inch diameter brush. Brush cutter must have replaceable blades.

**3.1.6.4** Hydraulic brush cutter attachment must be compatible with 3.1.1 Compact Excavator Brand and Model vendor bid for this solicitation.

**3.1.7 Hydraulic Plate Compactor**

**3.1.7.1** Hydraulic Plate compactor attachment must be Allied 400B or Equal.

**3.1.7.2** Hydraulic Plate compactor attachment must be compatible with the installed quick coupler pins installed and auxiliary hydraulics on the compact excavator.

**3.1.7.3** Hydraulic Plate compactor attachment must have a minimum impulse force of 4,000 pounds.

**3.1.7.4** Hydraulic Plate compactor attachment must have a minimum of 13 inch by 25 inch base compaction plate.

**3.1.8 Hydraulic Hammer/Breaker**

**3.1.8.1** Hydraulic hammer must be Rammer 522 or Equal.

**3.1.8.2** Hydraulic hammer must be compatible with the installed quick coupler (pins installed) and auxiliary hydraulics on the compact excavator.

**3.1.8.3** Hydraulic hammer must be equipped with a composite bushing which requires no greasing during operation. The tool must be unbreakable and guaranteed for life.

3.1.8.4 Hydraulic hammer must be in the five hundred (500) foot-pound energy class.

3.1.8.5 Hydraulic Hammer must be compatible with 3.1.1 Compact Excavator Brand and Model vendor bid for this solicitation.

**3.1.9 3/8" Ratchet Binders**

3.1.9.1 3/8" ratchet binder must be a ratcheting style with self-locking handle for grade 70 3/8" chain.

3.1.9.2 3/8" ratchet binder must have a clevis grab hook on each end.

3.1.9.3 3/8" ratchet binder must have a minimum of 8" take-up.

3.1.9.4 3/8" Ratchet binder must have a minimum working load limit of 9,200 pounds.

**3.1.10 3/8" X 20' Chain with Hooks**

3.1.10.1 3/8" X 20' Chain with hooks must be Grade 70 transport chain.

3.1.10.2 3/8" X 20' Chain with hooks must have a clevis grab hook on each end.

3.1.10.3 3/8" X 20' Chain with hooks must have a minimum working load limit of 6,600 pounds.

**3.1.11 Lifting apparatus**

3.1.11.1 Lifting straps shall be a minimum of two-inch-wide, single ply Nylon with eyes on each end. Each of the eyes shall be a minimum of ten inches long. The lifting straps shall have a minimum vertical lifting capacity of 3,100 pounds. The working load limits of the lifting straps shall be tagged on each unit. Straps shall be in the following lengths: Two in a four-foot (4') length. Three in a ten-foot (10') length.

**3.1.11.2** Triple leg chain sling shall be a minimum of grade 100 9/32" chain hung from an oblong solid master ring. Each chain leg shall be four-foot in length. Each leg shall be fitted with a latching style sling hook. A single leg of the chain sling shall have a minimum vertical lifting capacity of 3,500 pounds. The working load limits of the chain sling shall be tagged on the unit.

**3.1.11.3** A minimum 3/4" screw pin anchor shackle shall be galvanized carbon steel. The shackle shall have a minimum working load limit of 9,500 pounds.

**3.1.12 Minimum of 2,500 Hour Maintenance Agreement and Comprehensive Warranty**

**3.1.12.1** The minimum 2,500-hour maintenance agreement and extended comprehensive warranty shall be for item 3.1.1 the compact excavator. The minimum 2,500-hour maintenance agreement and comprehensive warranty must be provided for a minimum of the first 2,500 machine hours or 60 months of ownership whichever comes first.

**3.1.12.2** The preventive maintenance agreement must include all parts, labor, equipment, supplies, lubricants, etc., for the OEM suggested maintenance schedule. Fluid analysis must be included in each preventative maintenance session as recommended by the manufacturer.

**3.1.12.3** The extended comprehensive warranty shall cover the compact excavator after the initial factory warranty is expired. The comprehensive warranty must cover everything on the machine except for what is defined as Manufacturers' "wear items". "Wear items" including pins, tracks, etc. must be clearly defined on the summary as not covered.

**3.1.12.4** A summary of the coverage and full copies of the OEM initial factory warranty, maintenance agreement and extended comprehensive warranty should be provided with the vendors bid

REQUEST FOR QUOTATION  
Compact Excavator with Attachments

---

response. This information may be required before award of contract.

**4. CONTRACT AWARD:**

**4.1 Contract Award:** The Contract is intended to provide Agencies with a purchase price for the Contract Items. The Contract shall be awarded to the Vendor that provides the Contract Items meeting the required specifications for the lowest overall total cost as shown on the Pricing Pages.

**Pre-Delivery:** Prior to delivery each piece of equipment must be completely serviced in accordance with Manufacturers' Dealer "make ready" preparation and in accordance with these specifications and the Manufacturers' recommendations. Owner's manuals must be delivered with the equipment

**4.2 Pricing Page:** Vendor should complete the Pricing Page by entering the unit cost and extended cost to equal the total bid amount. Vendor should complete the Pricing Page in full as failure to complete the Pricing Page in its entirety may result in Vendor's bid being disqualified.

**4.2.1** Vendor's who wish to respond to a Centralized Request for Quotation (CRFQ) online may submit information through the State's wvOASIS Vendor Self Service (VSS).

Vendors should download the Exhibit "A" Pricing Page that is attached separately to the CRFQ and published to the VSS. Vendor must identify Brand, Model and Year equipment being bid and include it with their submitted bid response.

Any product brochures to support vendor's product should be submitted with vendor's bid response. These brochures and any supporting documentation may be required before award of contract.

Vendor should type or electronically enter the information into the Pricing Page to prevent errors in the evaluation.

**5. PAYMENT:**

**5.1 Payment:** Vendor shall accept payment in accordance with the payment procedures of the State of West Virginia.

REQUEST FOR QUOTATION  
Compact Excavator with Attachments

---

**6. DELIVERY AND RETURN:**

**6.1 Delivery Time:** Vendor shall ship the Contract Items immediately after being awarded this Contract and receiving a purchase order or notice to proceed. Vendor shall deliver the Contract Items within sixty (60) calendar day(s) after receiving a purchase order or notice to proceed. Vendor shall ship all orders in accordance with the above schedule and shall not hold orders until a minimum delivery quantity is met.

**6.2 Late Delivery:** The Agency placing the order under this Contract must be notified in writing if the shipment of the Contract Items will be delayed for any reason. Any delay in delivery that could cause harm to the Agency will be grounds for cancellation of the Contract, and/or obtaining the Contract Items from a third party.

Any Agency seeking to obtain the Contract Items from a third party under this provision must first obtain approval of the Purchasing Division.

**6.3 Delivery Payment/Risk of Loss:** Vendor shall deliver the Contract Items F.O.B. destination to the Agency's location. Vendor shall include the cost of standard order delivery charges in its bid pricing/discount and is not permitted to charge the Agency separately for such delivery

**6.4 Condition of Unit(s) Upon Delivery:** All units must arrive at the prescribed delivery point having been completely pre-serviced with oil, lubricants, and coolant. All prescribed precautions pertaining to first operations and break-in of the unit are to be posted conspicuously on the unit for ready observance by the operator.

**6.5 Delivery Point:** Delivery point of the completed unit will be the Blackwater River Drum Station Building located off Aqua Drive in Davis, West Virginia. GPS Location: 39°07'40.9"N -79°26'58.0"W

**7 VENDOR DEFAULT:**

**7.1** The following shall be considered a vendor default under this Contract.

**7.1.1** Failure to provide Contract Items in accordance with the requirements contained herein.

**7.1.2** Failure to comply with other specifications and requirements contained herein.

**7.1.3** Failure to comply with any laws, rules, and ordinances applicable to the Contract Services provided under this Contract.

REQUEST FOR QUOTATION  
Compact Excavator with Attachments

---

- 7.1.4 Failure to remedy deficient performance upon request.
- 7.2 The following remedies shall be available to Agency upon default.
  - 7.2.1 Immediate cancellation of the Contract.
  - 7.2.2 Immediate cancellation of orders issued under this Contract.
  - 7.2.3 Any other remedies available in law or equity.

**Exhibit A Pricing Page**  
**DEP Compact Excavator and Miscellaneous Equipment**

Item	QTY	Unit of Measure	Description	Brand Bid if 'or Equal'	Model Bid if 'or Equal'	Unit Price	Extended Cost
3.1.1	1	Ea	Compact Excavator	Caterpillar	303.5E2CR	\$49,194.21	\$49,194.21
3.1.2	1	Ea	12" Digging Bucket	Caterpillar	12" Bucket	\$638.00	\$638.00
3.1.3	1	Ea	24" Digging Bucket	Caterpillar	24" Bucket	\$800.00	\$800.00
3.1.4	1	Ea	36" Grading Bucket	Werk Brau	WTB36	\$4,555.00	\$4,555.00
3.1.5	1	Ea	Root Rake	TAG	2405R	\$1,151.00	\$1,151.00
3.1.6	1	Ea	Hydraulic Brush Cutter	Bushmaster	MX401-42SL	\$4,086.00	\$4,086.00
3.1.7	1	Ea	Hydraulic Plate Compactor	Caterpillar	CVP16	\$5,141.00	\$5,141.00
3.1.8	1	Ea	Hydraulic Hammer/Breaker	Caterpillar	H55E	\$7,428.00	\$7,428.00
3.1.9	5	Ea	3/8" Ratchet Binders	Redwing	3/8" Ratchet Binders	\$67.40	\$337.00
3.1.10	5	Ea	3/8" X 20' Chain with Hooks	Redwing	3/8" X 20' Chain with Hooks	\$44.60	\$223.00
3.1.11	2	Ea	2" Wide Lifting Straps 4' long	Redwing	2" Wide Lifting Straps 4' long	\$12.00	\$24.00
3.1.12	3	Ea	2" Wide Lifting Straps 10' long	Redwing	2" Wide Lifting Straps 10' long	\$23.00	\$69.00
3.1.13	1	Ea	Triple Leg Chain Sling	Redwing	Triple Leg Chain Sling	\$364.00	\$364.00
3.1.14	5	Ea	3/4" Screw Pin Anchor Shackle	Redwing	3/4" Screw Pin Anchor Shackle	\$35.00	\$175.00
3.1.15	1	Ea	2,500 Hour Maintenance Agreement and Comprehensive Warranty	Walker Machinery Co.	2,500 Hour Maintenance Agreement and Comprehensive Warranty	\$5,033.00	\$5,033.00
<b>TOTAL BID AMOUNT:</b>							<b>\$79,218.21</b>

**Company:** C.I. Walker Machinery Co.

**Address:** P.O. Box 2427

**City:** Charleston

**State:** WV



## Exceptions to DEP1800000001

- 3.1.1.14.2 The Quick Coupler shall be equipped with dual locks and a lifting eye.
  - The Caterpillar 303.5E2CR has a lifting eye designed into the bucket linkage bracket, not into the Caterpillar Quick Coupler.
  
- 3.1.1.19 Unit shall have a minimum lift capacity of 3,300 pounds at a minimum of 10 feet out and over the blade of the machine.
  - The Caterpillar 303.5E2CR has a published lift capacity of 3,020 pounds at 9'10" out and over the blade. However, Caterpillar rates lift capacities in compliance with standard ISO 10567:2007. The loads do not exceed 87% of hydraulic lifting capacity or 75% of tipping capacity.
  
- 3.1.7.3 Hydraulic Plate compactor attachment must have a minimum impulse force of 4,000 pounds.
  - The Caterpillar CVP16 has an impulse force of 3,650 pounds.
  
- 3.1.7.4 Hydraulic Plate compactor attachment must have a minimum of 13 inch by 25 inch base compaction plate.
  - The Caterpillar CVP16 has a 12 inch by 24 inch base compaction plate.
  
- 3.1.8.3 Hydraulic hammer must be equipped with a composite bushing which requires no greasing during operation. The tool must be unbreakable and guaranteed for life.
  - The Caterpillar H55E hammer does require greasing during operation. The tool is not unbreakable or guaranteed for life.

# 303.5E2 CR, 304E2 CR, 305E2 CR, 305.5E2 CR



Mini Hydraulic Excavators



	303.5E2 CR	304E2 CR	305E2 CR	305.5E2 CR
<b>Engine</b>				
Engine Model	Cat® C1.7	Cat C2.4	Cat C2.4	Cat C2.4
Net Power (ISO 9249)	17.5 kW (23.5 hp)	30 kW (40.2 hp)	30 kW (40.2 hp)	32.9 kW (44.2 hp)
<b>Weights</b>				
Operating Weight with Canopy	3539 kg (7,803 lb)	3884 kg (8,564 lb)	5020 kg (11,069 lb)	5259 kg (11,596 lb)
Operating Weight with Cab	3723 kg (8,209 lb)	4039 kg (8,906 lb)	5185 kg (11,433 lb)	5423 kg (11,958 lb)
<b>Operating Specifications</b>				
Maximum Dig Depth	3180 mm (125 in)	3430 mm (135 in)	3670 mm (144 in)	3870 mm (152 in)

**The right  
machine  
with the  
right power,  
versatility  
and ease  
of operation  
required  
for your  
application.**



**Contents**

Operator Station.....	4
Operation and Hydraulic Control.....	5
Engine.....	5
COMPASS Control Panel.....	6
Compact Radius Design.....	8
Undercarriage.....	9
Dozer Blade.....	10
Coupler and Work Tool Options.....	11
Serviceability and Support.....	12
Specifications.....	13
Standard Equipment.....	19
Optional Equipment.....	19



**The Cat E2 Series Mini Hydraulic Excavators are designed to carry on the solid performance of their E Series predecessors, while adding even greater value for the customer. The new High Definition Hydraulic (HDH) System, redesigned operator station and enhanced digital control panel specially designed for Cat Mini Excavators – COIPASS (Complete, Operation, Maintenance, Performance And Security System) – are all standard features that improve performance and increase value.**

# Operator Station

## Productivity with Comfort and Quality

### Comfortable Working Environment

The high quality suspension seat, 76 mm (3 in) retractable seat belt, easy to adjust armrests, and ergonomic layout provide superior comfort and reduce operator fatigue. The new interlocking front window system, updated operator interface and 100% pilot controls provide a best-in-class operator station and customer value.

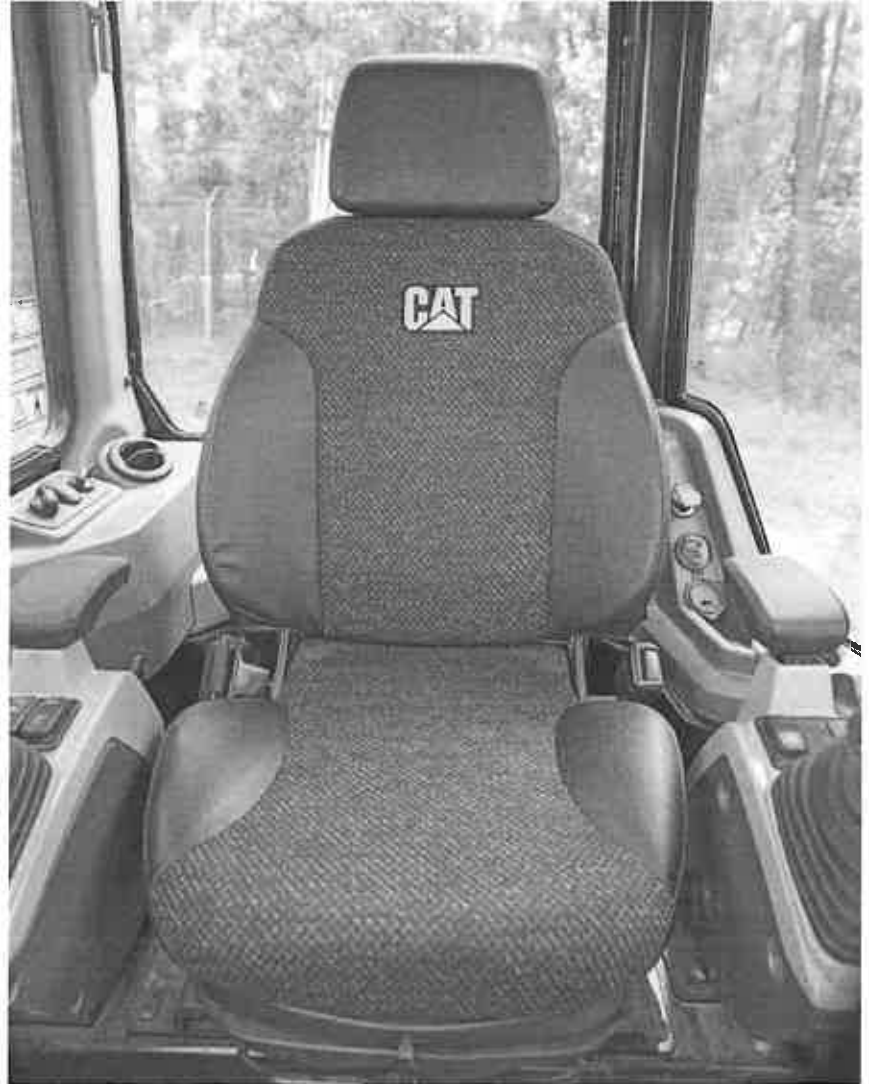

### Joystick Controls

The boom swing and auxiliary hydraulic functions are located at your fingertips providing smooth, easy operation. They also eliminate foot pedals and free up the floor for more room for the operator's feet. 100% pilot controls provide consistent flow and pressure throughout the life of the machine. This allows all controls to be locked out while starting the machine.



# Operation and Hydraulic Control

## Pushing Performance to the Limit

### Powerful Digging, Precise Control

The new High Definition Hydraulic (HDH) System in the E2 machines provides a load sensing and flow sharing capability leading to operational precision, efficient performance and greater control. By combining variable pump efficiency, open center valve simplicity, and a simple architecture the valve achieves controllability. The simple valve architecture reduces heat which leads to a reduction in hydraulic instability and improved overall efficiency.

### 200 Degree Bucket Rotation

Industry leading bucket rotation of over 200 degrees provides greater material retention during truck loading.

It also allows for easier vertical wall digging without repositioning the machine.

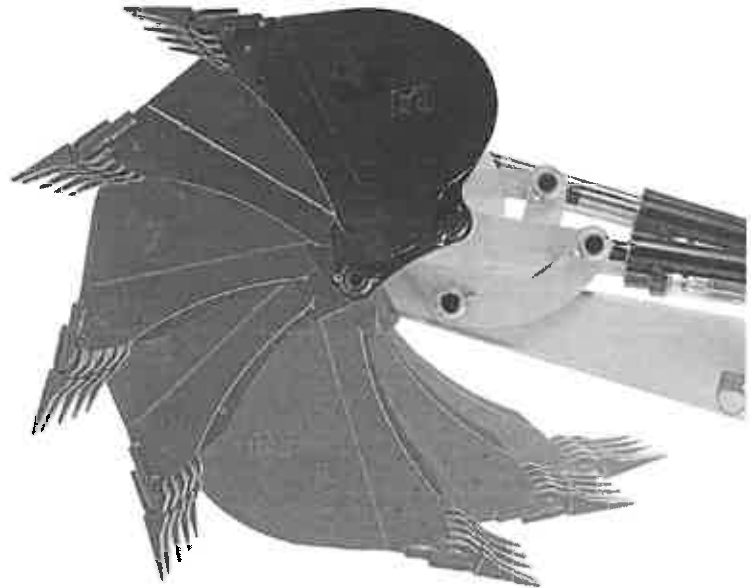

## Engine

### Intelligent Operation

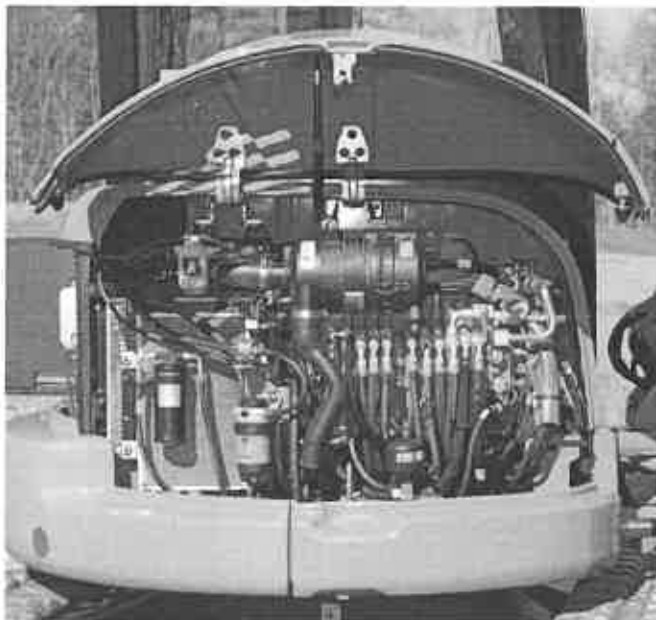

### Engine

Each of the E2 models is equipped with the engine solution to best support the power and performance required based on the weight class and application. Also, standard features like auto idle offer consistent lower engine speeds to increase engine life and offer fuel savings.

Smart Technology is a new feature of the 303.5E2. Through the integration of this technology with the U.S. EPA Tier 4 Final 23.5 hp (17.6 kW) engine, the machine is able to meet and exceed performance of the previous generation 303.5E. Additionally, testing on the 303.5E2 revealed an 8% fuel economy improvement and 7% greater efficiency over the E Series.

### Automatic Two Speed

With the standard automatic two speed feature, the machine will automatically balance high speed and torque travel requirements based on job site conditions to give the operator the optimum speed and control. The machine can be put in low gear if slower travel is desired while in tight conditions.



# COMPASS Control Panel

Complete, Operation, Maintenance, Performance and Security System



The COMPASS control panel on the Cat E2 Series mini hydraulic excavators was specifically designed by Caterpillar for compact excavators. It adds several new features to the machines increasing the amount of customer value. All of the following features are now standard on all E2 Series models.

**Complete** – All of the control panel features are standard

**Operation** – Simple operation of the pattern changer, hydraulic quick coupler and fuel gauge visibility all at the push of a button

**Maintenance** – Maintenance intervals, diagnostics and work hours

**Performance** – Save up to 20% fuel while maintaining optimum performance levels

**And**

**Security** – Anti-theft device with individual user and master passwords

**System** – Ergonomically designed control panel



## Passcode Protected Security System

A standard anti-theft device now comes on every E2 Series compact excavator. A five digit alphanumeric password is required to start the machine when the anti-theft feature is enabled. There is a master password and up to five user passwords can be created by the owner if desired.

*Keep your machine safe on a busy job site by locking it when you are not around*

## Adjustable Auxiliary Work Tool Flow Control

The E2 Series machines now have simple adjustability of the flow going down the boom and stick to the work tool. Both the standard main line and optional secondary auxiliary hydraulics can be adjusted on a scale of 1–15 through a few buttons on the control panel.

*Adjust the flow to your different tools with a simple push of a button*



**UNLOCK** the new features and experience the value of the exclusive COMPASS control panel on the E2 Series compact excavators



### **Continuous Flow**

Once this feature is enabled through a button on the monitor, the E2 Series machines can run in continuous flow mode. With the auxiliary hydraulics on the right hand joystick, just hold the roller switch at the desired flow rate and direction for 2.5 seconds and the machine will maintain that flow rate until it is turned off.

*Maintain hydraulic flow to your tools at any flow and in any direction with the simple push of a button*



### **Pattern Changer**

Change the operating pattern between excavator and backhoe with a simple press of a button from the comfort of the cab.

*Exclusive push button pattern changer is safe and easy*



### **Maintenance and Performance Information**

Easily keep track of various maintenance and performance parameters of your machine.

*Reset the maintenance intervals and ensure the machine is receiving proper care maximizing the life of the machine*







## **Compact Radius Design**

Ease of Transport, Access and Operation

### **Compact Radius**

The compact radius design gives greater machine versatility and the capability to work within confined areas. This allows the operator to concentrate on the work being done without having to worry about damaging the back of the machine or other job site obstacles. On the 305E2 CR and the 305.5E2 CR, the upper body stays within 140 mm (5.5 in) of the undercarriage.

### **Zero Tail Swing**

The 303.5E2 CR and the 304E2 CR models feature a zero tail swing design. On these models, the radius of the upper body stays entirely within the width of the undercarriage.

**Rubber Track** – The standard rubber track lets you work on multiple surfaces such as grass, pavement or stone without damaging the surface or machine.

**Steel Track Option** – Optional steel track is available for harsh conditions such as demolition. The extra weight of the steel tracks generally provides better stability when digging over the side of the machine.

**Rubber Pads** – Optional rubber pads can be attached to the steel track to prevent damage to paved surfaces and minimize noise and vibration during travel with the steel track system. This option provides the maximum overall stability. (Not available on the 303.5E2 CR and 304E2 CR.)

## Undercarriage A Strong Foundation



# Dozer Blade

Maximize your productivity

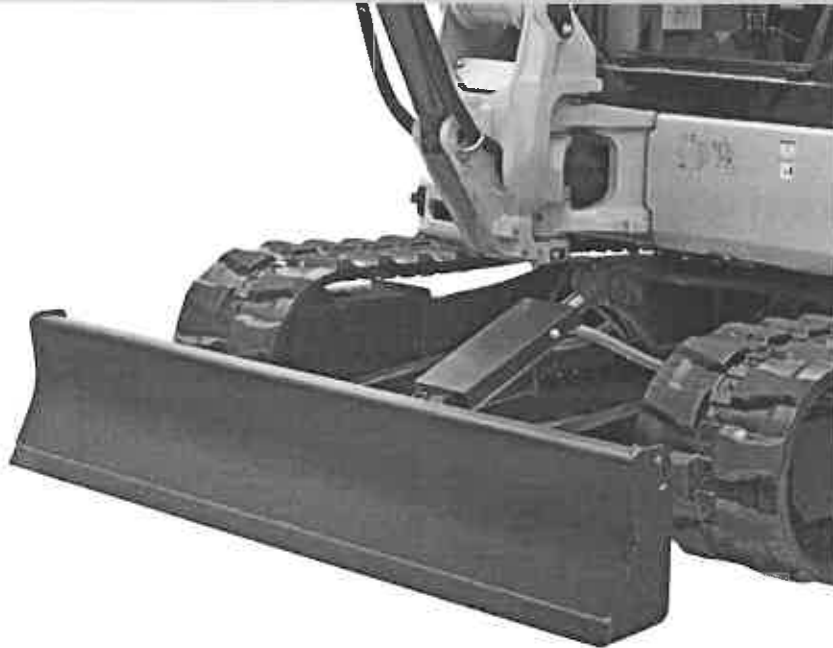

## Simple Dozer Control with Float Function

The dozer function is pilot controlled from inside the cab, providing smooth, proportional operation. The standard float function is enabled by pushing the lever fully forward into the detent position. Cleanup and backfilling is easier since the operator does not have to adjust the blade height during travel.

## Excellent Blade Visibility

Visibility to the blade is excellent in any position, allowing the blade to be positioned behind the operator and away from the front linkage for better access when back dragging and finishing in tight areas.

## Angle Blade Option

Increase machine versatility with the Cat angle dozer blade. Built for strength and durability, the hydraulic angle blade features a hardened steel wear edge and good protection to cylinders and hydraulic lines. The angle blade can be positioned straight ahead or angled up to 25 degrees to the left or right. This reduces the number of times required to back up and reposition when backfilling so you can finish the job faster. All functions of the blade are controlled with one joystick using a proportional roller switch for the angle function.

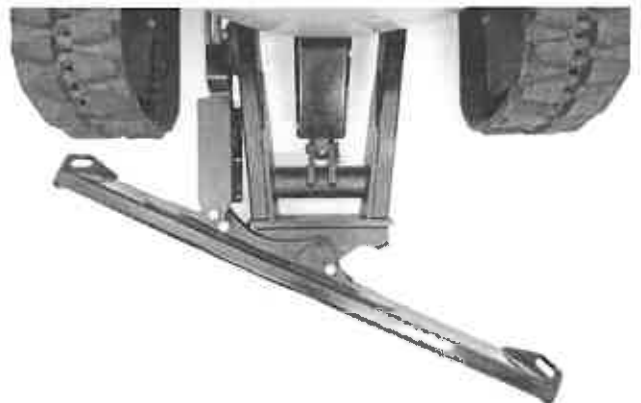
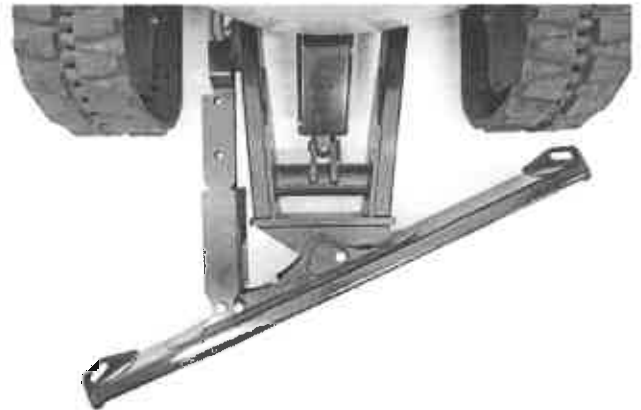

# Coupler and Work Tool Options

## Versatility for Any Application

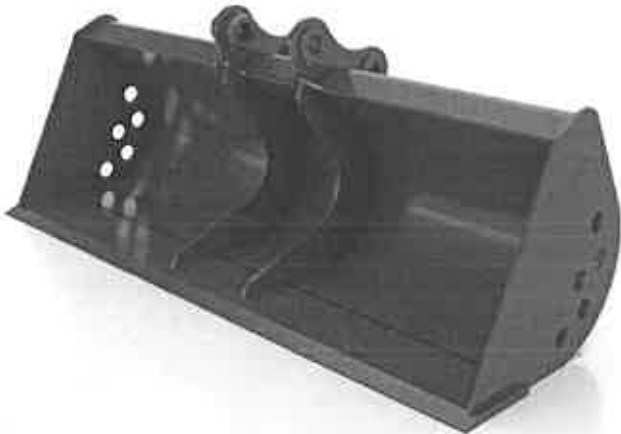
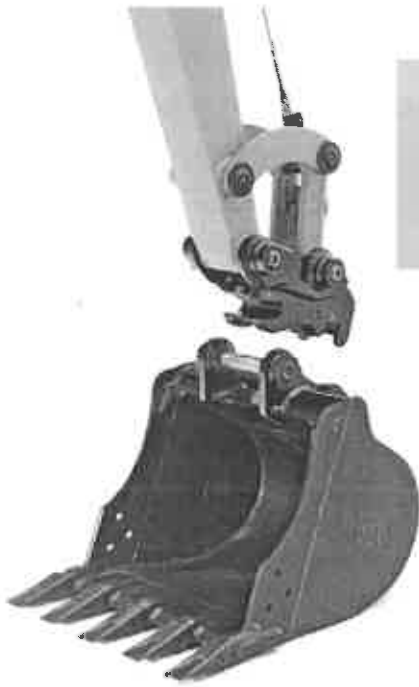

### Couplers

The E2 Series is available with a mechanical pin-grabber or a hydraulic pin-grabber quick coupler option. The coupler design uses a wedge to keep the tool secure to the coupler, reducing wear and maintaining a tight fit through the life of the coupler.

The hydraulic coupler allows the operator to change tools without leaving the comfort of the cab.

### Wide Range of Work Tools

A wide range of Cat Work Tools have been designed specifically for the Cat Mini Hydraulic Excavators to maximize machine performance. Available work tools include:

- Buckets (heavy duty and heavy duty capacity)
- Tilting, Ditch Cleaning Buckets
- Hydraulic Hammers
- Augers
- Thumbs (not available in all regions)
- Vibratory Compactors
- Shears (boom mounted on 305E2 CR/305.5E2 CR only)
- Quick Coupler

### Standard Thumb Ready Sticks

Machines come standard with stick mounted brackets, ready to fit a hydraulic thumb for even greater machine versatility.

A factory installed bracket and relief valve make hydraulic thumb installation simple and cost-effective.

### Standard Auxiliary Lines and Accumulator

One-way and two-way auxiliary lines (combined function), including quick connections, are fitted as standard equipment so the machine comes ready to work. A standard accumulator allows for auxiliary pressure to be released, making connecting and disconnecting work tools safer and easier.

# Serviceability and Support

Maximized Uptime and Ease of Service



## Easy Service

Extended service intervals, durable components, and ease of service access points decrease your owning and operating costs while increasing your long-term value.

- Lifting side hood allows access to air filter, main implement valve, 1-way/2-way auxiliary flow selector, accumulator, fuel filter and hydraulic tank. This eliminates the need to lift the cab when maintaining and servicing the machine.
- Swing open door provides access to major components and service points including engine oil check and fill, vertically mounted engine oil filter, starter motor and alternator.
- Easy access to the radiator and oil cooler results in simplified cleaning and reduced maintenance times.
- S-O SSM oil sampling valve allows easy sampling of the hydraulic fluid for preventative maintenance.
- 500 hour engine oil and filter change period reduces operating costs and machine downtime.

## Customer Support You Can Count On

Your Cat dealer is ready to assist you with your purchase decision and everything after.

- Financing packages are flexible to meet your needs.
- Unmatched parts availability keeps you working.
- Make comparisons of machines, with estimates of component life, preventative maintenance and cost of production.
- Your Cat dealer can evaluate the cost to repair, rebuild and replace your machine.
- For more information on Cat products, dealer services and industry solutions, visit [www.cat.com](http://www.cat.com).

## 303.5E2 CR, 304E2 CR, 305E2 CR, 305.5E2 CR Specifications

### Engine

Engine Model		
303.5E2 CR	Cat C1.7*	
304E2 CR/305E2 CR/305.5E2 CR	Cat C2.4**	
Rated Net Power (ISO 9249)		
303.5E2 CR	17.5 kW	23.5 hp
304E2 CR/305E2 CR	30 kW	40.2 hp
305.5E2 CR	32.9 kW	44.1 hp
Gross Power		
303.5E2 CR	18.5 kW	24.8 hp
304E2 CR/305E2 CR	31.2 kW	41.8 hp
305.5E2 CR	34.1 kW	45.7 hp
Bore		
	87 mm	3.4 in
Stroke		
303.5E2 CR	92.4 mm	3.6 in
304E2 CR/305E2 CR/305.5E2 CR	102.4 mm	4 in
Displacement		
303.5E2 CR	1.7 L	104 in <sup>3</sup>
304E2 CR/305E2 CR/305.5E2 CR	2.4 L	146 in <sup>3</sup>

\* Cat C1.7 engine meets U.S. EPA Tier 4 Final/EU Stage IIIB emission standards.

\*\* Cat C2.4 engine meets U.S. EPA Tier 4 Interim/EU Stage IIIA emission standards.

### Weights\*

Operating Weight with Canopy		
303.5E2 CR	3539 kg	7,803 lb
304E2 CR	3884 kg	8,564 lb
305E2 CR	5020 kg	11,069 lb
305E2 CR	5259 kg	11,596 lb
Operating Weight with Cab		
303.5E2 CR	3723 kg	8,209 lb
304E2 CR	4039 kg	8,906 lb
305E2 CR	5185 kg	11,433 lb
305E2 CR	5423 kg	11,958 lb

\* Weight includes rubber tracks, bucket, operator, full fuel and auxiliary lines.

### Travel System

Travel Speed – High		
303.5E2 CR	4.6 km/h	2.9 mph
304E2 CR	5.2 km/h	3.2 mph
305E2 CR	4.4 km/h	2.7 mph
305.5E2 CR	4.5 km/h	2.8 mph
Travel Speed – Low		
303.5E2 CR	3.2 km/h	2.0 mph
304E2 CR	3.3 km/h	2.1 mph
305E2 CR/305.5E2 CR	2.8 km/h	1.7 mph
Maximum Traction Force – High Speed		
303.5E2 CR	17.0 kN	3,822 lbf
304E2 CR	16.9 kN	3,799 lbf
305E2 CR	24.1 kN	5,418 lbf
305.5E2 CR	26.8 kN	6,025 lbf
Maximum Traction Force – Low Speed		
303.5E2 CR	31.1 kN	6,992 lbf
304E2 CR	31.0 kN	6,969 lbf
305E2 CR	45.2 kN	10,161 lbf
305.5E2 CR	47.8 kN	10,745 lbf
Ground Pressure		
303.5E2 CR	31.7 kPa	4.6 psi
304E2 CR	29.5 kPa	4.3 psi
305E2 CR	30.8 kPa	4.5 psi
305.5E2 CR	32.2 kPa	4.7 psi

### Service Refill Capacities

Cooling System		
303.5E2 CR/304E2 CR	5.5 L	1.5 gal
305E2 CR/305.5E2 CR	10.5 L	2.8 gal
Engine Oil		
303.5E2 CR/304E2 CR	7.0 L	1.8 gal
305E2 CR/305.5E2 CR	9.5 L	2.5 gal
Fuel Tank		
303.5E2 CR/304E2 CR	46 L	12.2 gal
305E2 CR/305.5E2 CR	63 L	16.6 gal
Hydraulic Tank		
303.5E2 CR/304E2 CR	42.3 L	11.2 gal
305E2 CR/305.5E2 CR	68.3 L	18 gal
Hydraulic System		
303.5E2 CR/304E2 CR	65 L	17.2 gal
305E2 CR/305.5E2 CR	78 L	20.6 gal

## 303.5E2 CR, 304E2 CR, 305E2 CR, 305.5E2 CR Specifications

### Hydraulic System\*

Pump Flow		
303.5E2 CR/304E2 CR	100 L/min	26.4 gal/min
305E2 CR	150 L/min	39.6 gal/min
305.5E2 CR	163 L/min	43.1 gal/min
Operating Pressure – Equipment		
245 bar	3,553 psi	
Operating Pressure – Travel		
245 bar	3,553 psi	
Operating Pressure – Swing		
216 bar	3,132 psi	
Auxiliary Circuit – Primary		
303.5E2 CR/304E2 CR	70 L/min	18.5 gal/min
305E2 CR/305.5E2 CR	80 L/min	21.1 gal/min
Auxiliary Circuit – Secondary		
25 L/min	6.6 gal/min	
Digging Force = Stick (standard)		
303.5E2 CR	18.9 kN	4,249 lbf
304E2 CR	21.6 kN	4,856 lbf
305E2 CR	24.7 kN	5,553 lbf
305.5E2 CR	28.9 kN	6,497 lbf
Digging Force = Stick (long)		
303.5E2 CR	16.9 kN	3,799 lbf
304E2 CR	19.5 kN	4,384 lbf
305E2 CR	21.3 kN	4,788 lbf
305.5E2 CR	24.8 kN	5,575 lbf
Digging Force = Bucket		
303.5E2 CR	33.0 kN	7,419 lbf
304E2 CR	37.8 kN	8,498 lbf
305E2 CR	44.7 kN	10,049 lbf
305.5E2 CR	50.9 kN	11,443 lbf

\* Load sensing hydraulics with variable displacement piston pump.

### Swing System

Machine Swing Speed	10 rpm
Boom Swing – Left (without stop)	
303.5E2 CR/305E2 CR/305.5E2 CR	80°
304E2 CR	70°
Boom Swing – Left (with stop)	
303.5E2 CR/304E2 CR	55°
305E2 CR/305.5E2 CR	60°
Swing – Right	
	50°

### Blade

Width		
303.5E2 CR	1780 mm	70 in
304E2 CR	1950 mm	77 in
305E2 CR/305.5E2 CR	1980 mm	78 in
Height		
303.5E2 CR/304E2 CR	325 mm	13 in
305E2 CR/305.5E2 CR	375 mm	14.8 in
Dig Depth		
303.5E2 CR/304E2 CR	470 mm	19 in
305E2 CR/305.5E2 CR	555 mm	21.9 in
Lift Height		
303.5E2 CR/304E2 CR	400 mm	16 in
305E2 CR/305.5E2 CR	405 mm	15.9 in

# 303.5E2 CR, 304E2 CR, 305E2 CR, 305.5E2 CR Specifications

## 303.5E2 CR Dimensions

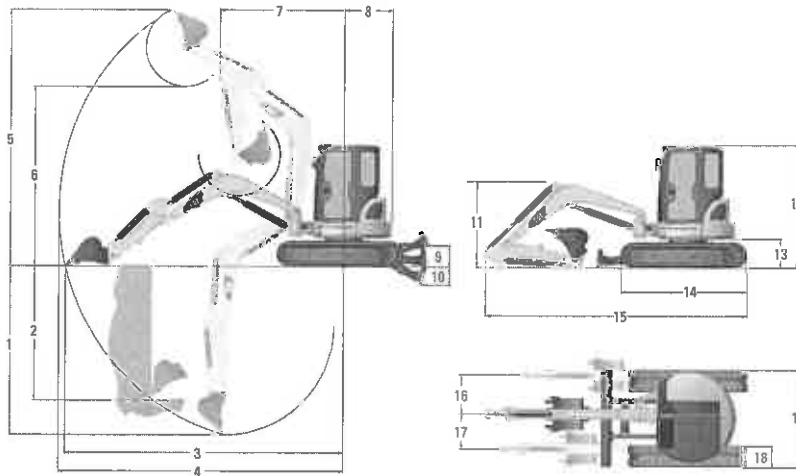

	Standard Stick		Long Stick	
1 Dig Depth	2880 mm	113 in	3180 mm	125 in
2 Vertical Wall	2320 mm	91 in	2470 mm	97 in
3 Maximum Reach at Ground Level	5060 mm	199 in	5320 mm	209 in
4 Maximum Reach	5200 mm	205 in	5440 mm	214 in
5 Maximum Dig Height	4920 mm	194 in	5030 mm	198 in
6 Maximum Dump Clearance	3520 mm	139 in	3640 mm	143 in
7 Boom In Reach	2060 mm	81 in	2180 mm	86 in
8 Tail Swing	890 mm	35 in	890 mm	35 in
9 Maximum Blade Height	400 mm	16 in	400 mm	16 in
10 Maximum Blade Depth	470 mm	19 in	470 mm	19 in
11 Boom Height in Shipping Position	1420 mm	56 in	1650 mm	65 in
12 O/A Shipping Height	2500 mm	98 in	2500 mm	98 in
13 Swing Bearing Height	565 mm	22 in	565 mm	22 in
14 O/A Undercarriage Length	2220 mm	87 in	2220 mm	87 in
15 O/A Shipping Length	4730 mm	186 in	4790 mm	189 in
16 Boom Swing Right	765 mm	30 in	765 mm	30 in
17 Boom Swing Left	670 mm	26 in	670 mm	26 in
18 Track Belt/Shoe Width	300 mm	12 in	300 mm	12 in
19 O/A Track Width	1780 mm	70 in	1780 mm	70 in

## 303.5E2 CR Lift Capacities at Ground Level\*

Lift Point Radius	3000 mm (9'8")		4000 mm (13'1")		
	Front	Side	Front	Side	
Blade Down	kg	1340	720	850	460
	lb	2,955	1,588	1,874	1,014
Blade Up	kg	750	660	470	420
	lb	1,654	1,455	1,036	926

\* The above loads are in compliance with hydraulic excavator lift capacity rating standard ISO 10567:2007 and they do not exceed 87% of hydraulic lifting capacity or 75% of tipping capacity. The excavator bucket weight is not included on this chart. Lifting capacities are for long stick.



# 303.5E2 CR, 304E2 CR, 305E2 CR, 305.5E2 CR Specifications

## 304E2 CR Dimensions

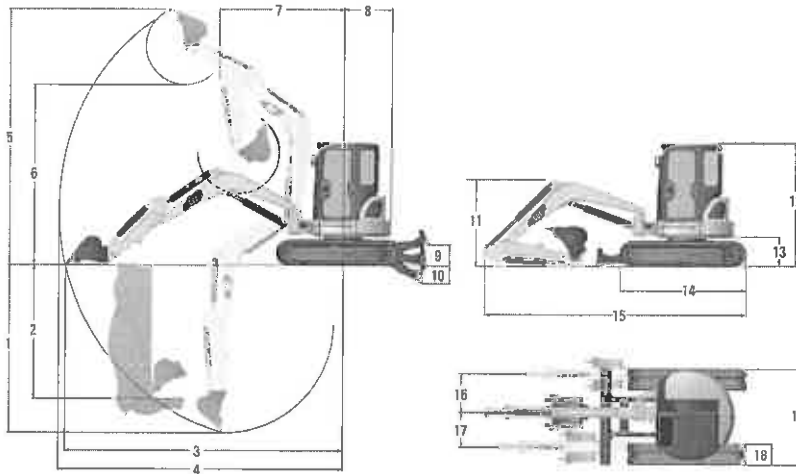

	Standard Stick		Long Stick	
1 Dig Depth	3130 mm	123 in	3430 mm	135 in
2 Vertical Wall	2420 mm	95 in	2560 mm	101 in
3 Maximum Reach at Ground Level	5220 mm	206 in	5470 mm	215 in
4 Maximum Reach	5350 mm	211 in	5590 mm	220 in
5 Maximum Dig Height	4980 mm	196 in	5070 mm	200 in
6 Maximum Dump Clearance	3590 mm	141 in	3690 mm	145 in
7 Boom In Reach	2110 mm	83 in	2220 mm	87 in
8 Tail Swing	975 mm	38 in	975 mm	38 in
9 Maximum Blade Height	400 mm	16 in	400 mm	16 in
10 Maximum Blade Depth	470 mm	19 in	470 mm	19 in
11 Boom Height in Shipping Position	1480 mm	58 in	1770 mm	70 in
12 O/A Shipping Height	2500 mm	98 in	2500 mm	98 in
13 Swing Bearing Height	565 mm	22 in	565 mm	22 in
14 O/A Undercarriage Length	2220 mm	87 in	2220 mm	87 in
15 O/A Shipping Length	4820 mm	190 in	4930 mm	194 in
16 Boom Swing Right	735 mm	29 in	735 mm	29 in
17 Boom Swing Left	670 mm	26 in	670 mm	26 in
18 Track Belt/Shoe Width	350 mm	14 in	350 mm	14 in
19 O/A Track Width	1950 mm	77 in	1950 mm	77 in

## 304E2 CR Lift Capacities at Ground Level\*

Lift Point Radius		3000 mm (9'8")		4500 mm (14'9")	
		Front	Side	Front	Side
Blade Down	kg	1570	910	860	480
	lb	3,462	2,007	1,896	1,058
Blade Up	kg	820	820	430	430
	lb	1,808	1,808	948	948

\* The above loads are in compliance with hydraulic excavator lift capacity rating standard ISO 10567:2007 and they do not exceed 87% of hydraulic lifting capacity or 75% of tipping capacity. The excavator bucket weight is not included on this chart. Lifting capacities are for long stick.

# 303.5E2 CR, 304E2 CR, 305E2 CR, 305.5E2 CR Specifications

## 305E2 CR Dimensions

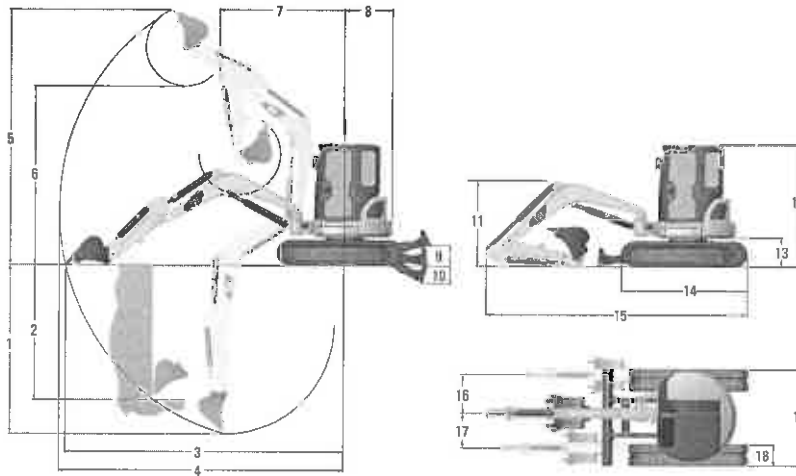

	Standard Stick		Long Stick	
1 Dig Depth	3280 mm	129 in	3670 mm	144 in
2 Vertical Wall	2320 mm	91 in	2630 mm	104 in
3 Maximum Reach at Ground Level	5430 mm	210 in	5810 mm	229 in
4 Maximum Reach	5600 mm	220 in	5960 mm	235 in
5 Maximum Dig Height	5250 mm	207 in	5440 mm	214 in
6 Maximum Dump Clearance	3720 mm	129 in	3920 mm	154 in
7 Boom In Reach	2350 mm	93 in	2530 mm	100 in
8 Tail Swing	1100 mm	43 in	1100 mm	43 in
9 Maximum Blade Height	405 mm	16 in	405 mm	16 in
10 Maximum Blade Depth	555 mm	22 in	555 mm	22 in
11 Boom Height in Shipping Position	1750 mm	69 in	2150 mm	85 in
12 O/A Shipping Height	2550 mm	100 in	2550 mm	100 in
13 Swing Bearing Height	615 mm	24 in	615 mm	24 in
14 O/A Undercarriage Length	2580 mm	102 in	2580 mm	102 in
15 O/A Shipping Length	5180 mm	204 in	5290 mm	208 in
16 Boom Swing Right	785 mm	31 in	785 mm	31 in
17 Boom Swing Left	695 mm	27 in	695 mm	27 in
18 Track Belt/Shoe Width	400 mm	16 in	400 mm	16 in
19 O/A Track Width	1980 mm	78 in	1980 mm	78 in

## 305E2 CR Lift Capacities at Ground Level\*

Lift Point Radius		3000 mm (9'8")		4500 mm (14'9")	
		Front	Side	Front	Side
Blade Down	kg	2340	1200	1260	640
	lb	5,159	2,646	2,778	1,411
Blade Up	kg	1450	1070	760	570
	lb	3,197	2,359	1,676	1,257

\* The above loads are in compliance with hydraulic excavator lift capacity rating standard ISO 10567:2007 and they do not exceed 87% of hydraulic lifting capacity or 75% of tipping capacity. The excavator bucket weight is not included on this chart. Lifting capacities are for standard stick.

# 303.5E2 CR, 304E2 CR, 305E2 CR, 305.5E2 CR Specifications

## 305.5E2 CR Dimensions

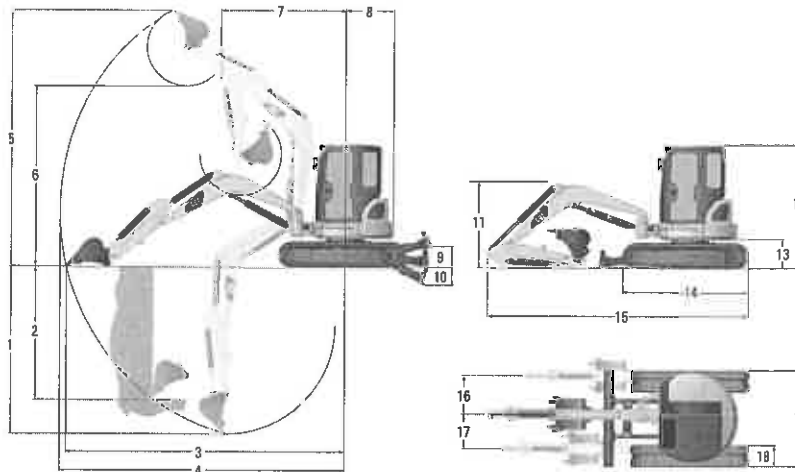

	Standard Stick		Long Stick	
1 Dig Depth	3470 mm	137 in	3870 mm	152 in
2 Vertical Wall	2330 mm	92 in	2730 mm	107 in
3 Maximum Reach at Ground Level	5630 mm	222 in	6020 mm	237 in
4 Maximum Reach	5790 mm	228 in	6170 mm	243 in
5 Maximum Dig Height	5330 mm	210 in	5590 mm	220 in
6 Maximum Dump Clearance	3820 mm	150 in	4080 mm	161 in
7 Boom In Reach	2400 mm	94 in	2530 mm	100 in
8 Tail Swing	1130 mm	44 in	1130 mm	44 in
9 Maximum Blade Height	405 mm	16 in	405 mm	16 in
10 Maximum Blade Depth	555 mm	22 in	555 mm	22 in
11 Boom Height in Shipping Position	1740 mm	69 in	2150 mm	85 in
12 O/A Shipping Height	2550 mm	100 in	2550 mm	100 in
13 Swing Bearing Height	615 mm	24 in	615 mm	24 in
14 O/A Undercarriage Length	2580 mm	102 in	2580 mm	102 in
15 O/A Shipping Length	5330 mm	210 in	5460 mm	215 in
16 Boom Swing Right	785 mm	31 in	785 mm	31 in
17 Boom Swing Left	695 mm	27 in	695 mm	27 in
18 Track Belt/Shoe Width	400 mm	16 in	400 mm	16 in
19 O/A Track Width	1980 mm	78 in	1980 mm	78 in

## 305.5E2 CR Lift Capacities at Ground Level\*

Lift Point Radius		3000 mm (9'8")		4500 mm (14'9")	
		Front	Side	Front	Side
Blade Down	kg	2590	1290	1380	690
	lb	5,710	2,844	3,042	1,521
Blade Up	kg	1550	1150	820	620
	lb	3,417	2,535	1,808	1,367

\* The above loads are in compliance with hydraulic excavator lift capacity rating standard ISO 10567:2007 and they do not exceed 87% of hydraulic lifting capacity or 75% of tipping capacity. The excavator bucket weight is not included on this chart. Lifting capacities are for standard stick.

## 303.5E2 CR, 304E2 CR, 305E2 CR, 305.5E2 CR Standard Equipment

### Standard Equipment

Standard equipment may vary. Consult your Cat dealer for details.

- 1-way and 2-way (combined function) auxiliary hydraulic lines
- Adjustable auxiliary flow control for work tools
- Adjustable wrist rests
- Alternator
- Anti-theft security system
- Automatic engine idle
- Automatic swing park brake
- Automatic two speed travel
- Auxiliary line quick disconnects
- Boom cylinder guard
- Cab mounted work light
- Canopy with Top Guard ISO 10262 (Level 1), ROPS ISO 12117-2 and TOPS ISO 12117
- Coat hook
- COMPASS display panel
- Cup holder
- Continuous flow
- Control pattern changer (not available in Europe)
- Dozer blade with float function
- Floor mat
- Foot travel pedals
- Horn
- Hydraulic oil cooler
- Lifting eye on bucket linkage (standard equipment for all regions except Europe)
- Lockable storage box
- Low maintenance linkage pin joints
- Maintenance free battery
- Rubber track
- Retractable seatbelt
- Stick
  - 303.5E2 CR/304E2 CR – Long stick (optional in Europe)
  - 305E2 CR/305.5E2 CR – Standard stick
- Suspension seat, vinyl covered
- Thumb Ready sticks (standard equipment for all regions except Europe)
- Travel alarm (optional in Europe)

## 303.5E2 CR, 304E2 CR, 305E2 CR, 305.5E2 CR Optional Equipment

### Optional Equipment

Optional equipment may vary. Consult your Cat dealer for details.

- Air conditioning
- Angle dozer blade with float function
- Beacon socket for canopy machines
- Boom check valve (Europe only)
- Boom mounted light
- Cab, radio ready with Top Guard ISO 10262 (Level 1), ROPS ISO 12117-2 and TOPS ISO 12117 with heater/defroster, interior light and windshield wiper/washer
- Ecology drain valve for hydraulic tank
- High back suspension seat, fabric covered
- Hydraulic quick coupler lines
- Lifting eye on bucket linkage (optional in Europe, standard for all other regions)
- Stick
  - 303.5E2 CR/304E2 CR – Standard stick (Europe only)
  - 305E2 CR/305.5E2 CR – Long stick
- Mechanical quick coupler
- Mirrors for cab and canopy
- Seatbelt, 75 mm (3 in) wide (optional in Europe, standard in all other regions)
- Secondary auxiliary hydraulic lines
- Steel track and steel track with rubber pads

For more complete information on Cat products, dealer services, and industry solutions, visit us on the web at [www.cat.com](http://www.cat.com)

AEHQ7365 (12-2014)

© 2014 Caterpillar  
All rights reserved

Materials and specifications are subject to change without notice. Featured machines in photos may include additional equipment. See your Cat dealer for available options.

CAT, CATERPILLAR, SAFETY.CAT.COM, their respective logos, "Caterpillar Yellow" and the "Power Edge" trade dress, as well as corporate and product identity used herein, are trademarks of Caterpillar and may not be used without permission.



**SERVICE****Equipment Protection Plan****Global****Machine****Premier Equipment Protection Plan****Overview**

This Equipment Protection Plan (EPP) addresses the coverage definitions on the base machine available for components that are covered under various new and used/rebuilt equipment programs offered through Caterpillar.

Premier EPP coverage is available for new Cat machines (except when EAME-specified Blanket Cat Certified Used Premier coverage terms are available). Refer to the Standard Machine Warranty and applicable program bulletins for covered component failures during the standard warranty period and refer to Premier EPP for covered component failures during the EPP coverage period.

**► Components Covered Under Premier EPP**

**Premier EPP** coverage is intended to reimburse for defects in material and workmanship of covered components. Coverage for defects in material and workmanship as defined by this bulletin means the failure of any original or Cat approved replacement part to work as designed in normal service, providing proper maintenance was received as recommended by the manufacturer in the Operation & Maintenance (O&M) Manual.

**Premier EPP** is a comprehensive component coverage that includes the components covered by Powertrain - EPP (Bulletin 8.01), Hydraulic - EPP (Bulletin 8.02), Hydraulic and Technology – EPP (Bulletin 8.10), and additional components not excluded by this bulletin.

**Components Excluded Under the Premier EPP:**

Premier EPP covers all warrantable defects during the standard factory warranty period. See warranty bulletin 2.01 for an explanation of warrantable defects. Upon expiration of the standard machine warranty, the following exclusions apply:

**Service Items** - Service items are excluded for defects in material and workmanship under the **Premier EPP** Coverage. Examples include:

- Coolant
- Lubricants (Oil)
- Additives and Conditioners
- Fluids
- Filters
- Fuel
- Diesel Exhaust Fluid

► 08.03-02 (03/17)

<https://warranty.cat.com/wtyguide>  
© 2017 Caterpillar All Rights Reserved.

► Indicates change.

CAT, CATERPILLAR, their respective logos, "Caterpillar Yellow" and the "Power Edge" trade dress, as well as corporate and product identity used herein, are trademarks of Caterpillar and may not be used without permission.

Dealer and Dealers are defined as any Cat Authorized Dealer or Cat Authorized Repair Representative.

For additional Service Items that are excluded, refer to the Global Service Warranty Guide.

Service items are reimbursed under **Premier EPP** only when a covered component failure causes resultant damage to the service item.

**Maintenance Items** - Specific maintenance intervals & requirements are defined within the O&M Manual for each individual model. Any procedures or scheduled replacement parts outlined within the "Maintenance" section of the O&M Manual are excluded from **Premier EPP** coverage. This would include inspections, testing, adjustments, repairs, replacement, or rebuild.

Examples include:

- V-Belts and Serpentine Belts
- Filters & Elements
- Fuses
- Windshield Wiper Blades
- Lamps, Lights & Light Bulbs (excluding LED Light Assemblies)
- Paint/Decals
- Weld Maintenance Structural Repairs (certain models)
- Planned component replacement
- Driveline wear items
- Service Brake Components – wear items including but not limited to, disc, plates, and linings, either internal or external

For additional maintenance items that are excluded, refer to the Global Service Warranty Guide.

Maintenance items are reimbursed under **Premier EPP** only when a covered component failure causes resultant-damage to the maintenance part.

**Components or Systems Covered by Other Caterpillar Warranty Statements:**

Examples include:

- Batteries
- Cat Work Tools
- Mobil-trac™ belts
- Rubber track used on Compact Construction Equipment (CCE).
- Machine Control & Guidance
- Cat Tires
- Service Tools and Supplies

For additional Components or Systems that are excluded, refer to the Global Service Warranty Guide.

**Components or Systems Not Included in Standard Machine Warranty:**

Examples include:

- CCE work tools

For additional Components or Systems that are excluded, refer to the Global Service Warranty Guide.

**Components or Systems Covered Beyond Standard Machine Warranty, regardless of enrollment or duration:**

Examples include:

- Moving Undercarriage (Refer to bulletins 5.01 & 5.02)
- Ground Engaging Tools (GET) (Refer to bulletin 4.03)
- Long-Life Weld-On Landfill Compactor Plus Tip (Refer to bulletin 4.03)

For additional components or systems that are excluded, refer to the Global Service Warranty Guide.

**Components Covered by Any Other Manufacturers' Warranty Statements:**

Examples include:

- Other Manufacturer Tires
- Other Manufacturer Hammers
- Timberking™ Products
- Forestry Work Tools
- Ag Products

**Other Excluded Components:**

- Glass
- Lens
- Radios
- Mini-Hydraulic Excavator rubber track belts (Covered under “Rubber Track Warranty For The Multi Terrain Loader and Compact Track Loader” bulletin 2.09)
- Effective for sales on/after 01Jul10, Hydraulic Line Quick Connect/Disconnect Components on CCE Machines. (Work Tools are excluded on page 2 of this bulletin.)

For additional components that are excluded, refer to the Global Service Warranty Guide.

## General Exclusions and Limitations

**Premier EPP** does not cover the following:

- Operator abuse, neglect, improper or abusive use of the machine including but not limited to the failure to perform the recommended preventative maintenance as specified in the Operation and Maintenance (O&M) Manual.
- Applications not approved by Caterpillar.
- Improper or abusive use of machine.
- Operation beyond the design and/or capacity of the machine.
- Wear-out and normal deterioration in performance, accelerated wear-out of components due to operating technique or application; including but not limited to oil consumption and gasket or seal leaks.
- Chemical corrosion and physical or mechanical erosion
- Unauthorized fuel setting changes.
- Acts of war, vandalism, riot, theft, explosion, collision, fire and/or any other act of nature, person or vermin.
- Operating equipment with improper, contaminated, or improper levels of fuel or fluids, or the use of improper filters.
- Modifications, unless the modifications were authorized at the request of Caterpillar and performed at an approved repair facility.
- Operating at performance settings other than the standard Caterpillar specification.
- Accelerated wear-out of components due to operating technique or application.
- Physical damage.
- Any repairs if the service meter has been stopped or altered or misrepresents the equipment's actual usage.
- Mechanical transportation or towing costs or field service travel expenses.
- Loss of time, inconvenience, downtime or downtime-related expenses or other incidental or consequential loss that results from a defect in material or workmanship.
- Any costs incurred to improve operating performance due to normal wear and tear.
- Storage or miscellaneous shop supplies.
- Mechanical Breakdown resulting from failure of a non-covered component.
- Freight and taxes.



- Any cost covered by any warranty of the manufacturer including emissions warranty or repairer's guarantee regardless of whether the warranty or repairer's guarantee is honored.
- Performance complaints including, but not limited to, adjustments to fuel settings or electronic unit injectors to comply with emissions standards under Environmental Protection Agency or similar national, federal, provincial or state law.
- Any costs incurred for the manufacturer to comply with emissions standards under the Environmental Protection Agency or similar national, federal, provincial or state law.
- Failure to use fuels and lubricants that meet or exceed the minimum specification requirements of the manufacturer as specified in the operations manual or other technical bulletins.

For machines enrolled in the **Premier EPP**, please refer to the Contractual Liability Policy (CLIP) for a complete list of exclusions and limitations. In the event of any ambiguity, the CLIP issued by Caterpillar Insurance Company will govern. Additional information regarding the CLIP policy may be obtained by contacting your dealership designated Warranty Manager.

## Customer's Responsibilities

The customer is responsible for assuring all recommended preventative maintenance is performed at the specified service intervals as described in the O&M Manuals. Preventative maintenance includes, but is not limited to the servicing, adjusting and/or replacing of specified components.

**Premier EPP** does not cover failure of any components as a result of not performing scheduled maintenance. The dealer may be required to provide proof of compliance with the maintenance schedules, at the time of a failure. Proof may include receipts or copies of work orders or invoices showing the performed maintenance services.

## S•O•S<sup>SM</sup> Fluid Analysis Test Results

S•O•S is not a requirement of the EPP program, however, it is recommended that at the point of enrollment, S•O•S sampling begin at the first recommended interval and continue throughout the remainder of the EPP coverage term.

## Wear-out and Extent of Coverage

Wear-out and/or deterioration are not covered by **Premier EPP**.

The intent is not to restore the product to a like-new condition, but rather to restore the product to its operating condition just prior to the covered failure. **Premier EPP** covers only the repair or replacement of the failed component and any resultant damaged parts. Other parts removed in the process of repair will be reinstalled "as is", unless the customer authorized the additional cost for their account.

**Example:** While performing a **Premier EPP** program repair for a piston ring failure, the dealer service technician notices the vee belts and coolant hoses are worn and deteriorated. He also notices some wear (within acceptable limits) on the cylinder head valve guides. In addition to the piston ring failure, the service technician replaces the vee belts and coolant hoses, and reconditions the valve guides to avoid future downtime.

In this example the vee belts, coolant hoses and valve guide reconditioning cannot be claimed to Caterpillar because they did not have a defect nor were they damaged as a result of the piston ring failure. They were repaired or replaced as a result of the customer responsibilities for assuring all recommended preventative maintenance is performed.

**NOTE:** If the piston ring failed due to abuse (running without changing oil at the proper interval), the ring failure and resultant damage would not be due to a Caterpillar defect, and therefore, not a covered failure.

# VENDOR PREFERENCE CERTIFICATE

Certification and application is hereby made for Preference in accordance with *West Virginia Code*, §5A-3-37. (Does not apply to construction contracts). *West Virginia Code*, §5A-3-37, provides an opportunity for qualifying vendors to request (at the time of bid) preference for their residency status. Such preference is an evaluation method only and will be applied only to the cost bid in accordance with the *West Virginia Code*. This certificate for application is to be used to request such preference. The Purchasing Division will make the determination of the Vendor Preference, if applicable.

1.  Application is made for 2.5% vendor preference for the reason checked:  
 Bidder is an individual resident vendor and has resided continuously in West Virginia for four (4) years immediately preceding the date of this certification; or,  
 Bidder is a partnership, association or corporation resident vendor and has maintained its headquarters or principal place of business continuously in West Virginia for four (4) years immediately preceding the date of this certification;  
 Bidder is a resident vendor partnership, association, or corporation with at least eighty percent of ownership interest of bidder held by another entity that meets the applicable four year residency requirement; or,  
 Bidder is a nonresident vendor which has an affiliate or subsidiary which employs a minimum of one hundred state residents and which has maintained its headquarters or principal place of business within West Virginia continuously for the four (4) years immediately preceding the date of this certification; or,

2.  Application is made for 2.5% vendor preference for the reason checked:  
 Bidder is a resident vendor who certifies that, during the life of the contract, on average at least 75% of the employees working on the project being bid are residents of West Virginia who have resided in the state continuously for the two years immediately preceding submission of this bid; or,

3.  Application is made for 2.5% vendor preference for the reason checked:  
 Bidder is a nonresident vendor that employs a minimum of one hundred state residents, or a nonresident vendor which has an affiliate or subsidiary which maintains its headquarters or principal place of business within West Virginia and employs a minimum of one hundred state residents, and for purposes of producing or distributing the commodities or completing the project which is the subject of the bidder's bid and continuously over the entire term of the project, on average at least seventy-five percent of the bidder's employees or the bidder's affiliate's or subsidiary's employees are residents of West Virginia who have resided in the state continuously for the two immediately preceding years and the vendor's bid; or,

4.  Application is made for 5% vendor preference for the reason checked:  
 Bidder meets either the requirement of both subdivisions (1) and (2) or subdivision (1) and (3) as stated above; or,

5.  Application is made for 3.5% vendor preference who is a veteran for the reason checked:  
 Bidder is an individual resident vendor who is a veteran of the United States armed forces, the reserves or the National Guard and has resided in West Virginia continuously for the four years immediately preceding the date on which the bid is submitted; or,

6.  Application is made for 3.5% vendor preference who is a veteran for the reason checked:  
 Bidder is a resident vendor who is a veteran of the United States armed forces, the reserves or the National Guard, if, for purposes of producing or distributing the commodities or completing the project which is the subject of the vendor's bid and continuously over the entire term of the project, on average at least seventy-five percent of the vendor's employees are residents of West Virginia who have resided in the state continuously for the two immediately preceding years.

7.  Application is made for preference as a non-resident small, women- and minority-owned business, in accordance with *West Virginia Code* §5A-3-59 and *West Virginia Code of State Rules*.  
 Bidder has been or expects to be approved prior to contract award by the Purchasing Division as a certified small, women- and minority-owned business.

Bidder understands if the Secretary of Revenue determines that a Bidder receiving preference has failed to continue to meet the requirements for such preference, the Secretary may order the Director of Purchasing to: (a) rescind the contract or purchase order; or (b) assess a penalty against such Bidder in an amount not to exceed 5% of the bid amount and that such penalty will be paid to the contracting agency or deducted from any unpaid balance on the contract or purchase order.

By submission of this certificate, Bidder agrees to disclose any reasonably requested information to the Purchasing Division and authorizes the Department of Revenue to disclose to the Director of Purchasing appropriate information verifying that Bidder has paid the required business taxes, provided that such information does not contain the amounts of taxes paid nor any other information deemed by the Tax Commissioner to be confidential.

Bidder hereby certifies that this certificate is true and accurate in all respects; and that if a contract is issued to Bidder and if anything contained within this certificate changes during the term of the contract, Bidder will notify the Purchasing Division in writing immediately.

Bidder: C.I. Walker Machinery Co.

Signed: [Signature]

Date: 9/11/17

Title: Sales Representative

\*Check any combination of preference consideration(s) indicated above, which you are entitled to receive.

## West Virginia Ethics Commission



### Disclosure of Interested Parties to Contracts

Pursuant to W. Va. Code § 6D-1-2, a state agency may not enter into a contract, or a series of related contracts, that has/have an actual or estimated value of \$100,000 or more until the business entity submits to the contracting state agency a Disclosure of Interested Parties to the applicable contract. In addition, the business entity awarded a contract is obligated to submit a supplemental Disclosure of Interested Parties reflecting any new or differing interested parties to the contract within 30 days following the completion or termination of the applicable contract.

For purposes of complying with these requirements, the following definitions apply:

*"Business entity"* means any entity recognized by law through which business is conducted, including a sole proprietorship, partnership or corporation.

*"Interested party" or "Interested parties"* means:

- (1) A business entity performing work or service pursuant to, or in furtherance of, the applicable contract, including specifically sub-contractors;
- (2) the person(s) who have an ownership interest equal to or greater than 25% in the business entity performing work or service pursuant to, or in furtherance of, the applicable contract. (This subdivision does not apply to a publicly traded company); and
- (3) the person or business entity, if any, that served as a compensated broker or intermediary to actively facilitate the applicable contract or negotiated the terms of the applicable contract with the state agency. (This subdivision does not apply to persons or business entities performing legal services related to the negotiation or drafting of the applicable contract.)

*"State agency"* means a board, commission, office, department or other agency in the executive, judicial or legislative branch of state government, including publicly funded institutions of higher education: Provided, that for purposes of W. Va. Code § 6D-1-2, the West Virginia Investment Management Board shall not be deemed a state agency nor subject to the requirements of that provision.

The contracting business entity must complete this form and submit it to the contracting state agency prior to contract award and to complete another form within 30 days of contract completion or termination.

*This form was created by the State of West Virginia Ethics Commission, 210 Brooks Street, Suite 300, Charleston, WV 25301-1804. Telephone: (304)558-0664; fax: (304)558-2169; e-mail: [ethics@wv.gov](mailto:ethics@wv.gov); website: [www.ethics.wv.gov](http://www.ethics.wv.gov).*

West Virginia Ethics Commission

Disclosure of Interested Parties to Contracts

Contracting business entity: C.I. Walker Machinery Co.

Address: P.O. Box 2427, Charleston, WV 25329

Contracting business entity's authorized agent: Matthew E. Conner

Address: P.O. Box 2427, Charleston, WV 25329

Number or title of contract: CRFQ 0313 DEP1800000001

Type or description of contract: Compact Excavator with Attachments

Governmental agency awarding contract: Environmental Protection

Names of each Interested Party to the contract known or reasonably anticipated by the contracting business entity (attach additional pages if necessary):

[Blank lines for names of interested parties]

Signature: [Handwritten Signature] Date Signed: 9/11/17

Check here if this is a Supplemental Disclosure.

Verification

State of WV, County of Kanawha

I, [Blank], the authorized agent of the contracting business entity listed above, being duly sworn, acknowledges that the Disclosure herein is being made under oath and under the penalty of perjury.

Taken, sworn to and subscribed before me this 11th day of September, 2017.

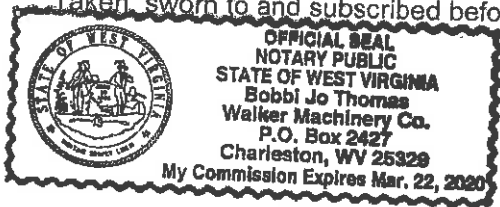

[Handwritten Signature: Bobbi Jo Thomas]
Notary Public's Signature

To be completed by State Agency:

Date Received by State Agency:

Date submitted to Ethics Commission:

Governmental agency submitting Disclosure:

STATE OF WEST VIRGINIA  
Purchasing Division

**PURCHASING AFFIDAVIT**

**CONSTRUCTION CONTRACTS:** Under W. Va. Code § 5-22-1(f), the contracting public entity shall not award a construction contract to any bidder that is known to be in default on any monetary obligation owed to the state or a political subdivision of the state, including, but not limited to, obligations related to payroll taxes, property taxes, sales and use taxes, fire service fees, or other fines or fees.

**ALL OTHER CONTRACTS:** Under W. Va. Code §5A-3-10a, no contract or renewal of any contract may be awarded by the state or any of its political subdivisions to any vendor or prospective vendor when the vendor or prospective vendor or a related party to the vendor or prospective vendor is a debtor and: (1) the debt owed is an amount greater than one thousand dollars in the aggregate; or (2) the debtor is in employer default.

**EXCEPTION:** The prohibition listed above does not apply where a vendor has contested any tax administered pursuant to chapter eleven of the W. Va. Code, workers' compensation premium, permit fee or environmental fee or assessment and the matter has not become final or where the vendor has entered into a payment plan or agreement and the vendor is not in default of any of the provisions of such plan or agreement.

**DEFINITIONS:**

"Debt" means any assessment, premium, penalty, fine, tax or other amount of money owed to the state or any of its political subdivisions because of a judgment, fine, permit violation, license assessment, defaulted workers' compensation premium, penalty or other assessment presently delinquent or due and required to be paid to the state or any of its political subdivisions, including any interest or additional penalties accrued thereon.

"Employer default" means having an outstanding balance or liability to the old fund or to the uninsured employers' fund or being in policy default, as defined in W. Va. Code § 23-2c-2, failure to maintain mandatory workers' compensation coverage, or failure to fully meet its obligations as a workers' compensation self-insured employer. An employer is not in employer default if it has entered into a repayment agreement with the Insurance Commissioner and remains in compliance with the obligations under the repayment agreement.

"Related party" means a party, whether an individual, corporation, partnership, association, limited liability company or any other form or business association or other entity whatsoever, related to any vendor by blood, marriage, ownership or contract through which the party has a relationship of ownership or other interest with the vendor so that the party will actually or by effect receive or control a portion of the benefit, profit or other consideration from performance of a vendor contract with the party receiving an amount that meets or exceeds five percent of the total contract amount.

**AFFIRMATION:** By signing this form, the vendor's authorized signer affirms and acknowledges under penalty of law for false swearing (W. Va. Code §61-5-3) that: (1) for construction contracts, the vendor is not in default on any monetary obligation owed to the state or a political subdivision of the state, and (2) for all other contracts, that neither vendor nor any related party owes a debt as defined above and that neither vendor nor any related party are in employer default as defined above, unless the debt or employer default is permitted under the exception above.

**WITNESS THE FOLLOWING SIGNATURE:**

Vendor's Name: C.I. Walker Machinery Co.

Authorized Signature: [Signature] Date: 9/11/17

State of WV

County of Kanawha, to-wit:

Taken, subscribed, and sworn to before me this 11<sup>th</sup> day of September, 2017.

My Commission expires 3-22, 2020.

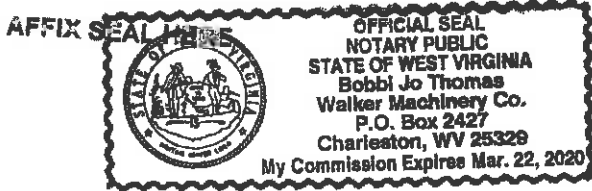

NOTARY PUBLIC [Signature]