



Purchasing Division
 2019 Washington Street East
 Post Office Box 50130
 Charleston, WV 25305-0130

State of West Virginia
 Request for Quotation
 13 - Equipment

Proc Folder: 322501

Doc Description: ADDENDUM_1: CLASS 135: BATWING ROTARY MOWER

Proc Type: Central Master Agreement

Date Issued	Solicitation Closes	Solicitation No	Version
2017-05-24	2017-06-01 13:30:00	CRFQ 0803 DOT1700000082	2

BID RECEIVING LOCATION

BID CLERK
 DEPARTMENT OF ADMINISTRATION
 PURCHASING DIVISION
 2019 WASHINGTON ST E
 CHARLESTON WV 25305
 US

VENDOR

Vendor Name, Address and Telephone Number:
 STATE EQUIPMENT, INC.
 P.O. BOX 3939
 CHARLESTON, WV 25339
 (304)776-4405

06/01/17 10:32:04
 WV Purchasing Division

FOR INFORMATION CONTACT THE BUYER

Mark A Atkins
 (304) 558-2307
 mark.a.atkins@wv.gov

Signature 

FEIN # 550658298

DATE 5/31/17

All offers subject to all terms and conditions contained in this solicitation

ADDITIONAL INFORMATION:

ADDENDUM_1 Is being published for the following:

1. To publish the Agency response to the questions received from Vendors during the Technical Questioning period.
2. To publish the pre-bid sign-in sheets.

No other changes made.

The West Virginia Purchasing Division is soliciting bids on behalf of the West Virginia Division of Highways, Department of Transportation to establish an open-end contract for a Class 135 Batwing Style Rotary Mower with 3-point hitch per attached documents.

MANDATORY PRE-BID MEETING:

DATE: MAY 17, 2017
TIME: 10:00am EST

LOCATION:

WV Division of Highways
Equipment Division
83 Brushy Road Crossing
Buckhannon, WV 26201

INVOICE TO	SHIP TO
DIVISION OF HIGHWAYS EQUIPMENT DIVISION RT 33 83 BRUSHY ROAD CROSSING, PO BOX 610 BUCKHANNON WV26201 US	DIVISION OF HIGHWAYS EQUIPMENT DIVISION 83 BRUSHY FORK RD CROSSING BUCKHANNON WV 26201 US

Line	Comm Ln Desc	Qty	Unit Issue	Unit Price	Total Price
1	Vendor shall use Exhibit_A Pricing Page(s) for bid pricing	0.00000	EA	\$15,947.00	\$15,947.00

Comm Code	Manufacturer	Specification	Model #
21101701	LAND PRIDE	BAT WING ROTARY MOWER	RC5616 SERIES 2

Extended Description :

CLASS 135 BATWING ROTARY MOWER w/ 3-point Hitch:

Note: Vendor shall use Exhibit_A Pricing Page for bid pricing.

If bidding online vendor should enter \$0.00 in the Oasis commodity line.

Vendor must attach the pricing page and the Exhibit_B information attachment to their bid.

See Section 18 of Instructions to Bidders for additional information.

SCHEDULE OF EVENTS

Line	Event	Event Date
1	Mandatory Pre-Bid Meeting @ 10:00am on:	2017-05-17
2	Technical Questions due by:	2017-05-22

DOT1700000082	Document Phase Final	Document Description ADDENDUM_1: CLASS 135: BATWING ROTARY MOWER	Page 3 of 3
---------------	--------------------------------	---	------------------------------

ADDITIONAL TERMS AND CONDITIONS

See attached document(s) for additional Terms and Conditions

ADDENDUM ACKNOWLEDGEMENT FORM
SOLICITATION NO.: CRFQ 0803 DOT170000082

Instructions: Please acknowledge receipt of all addenda issued with this solicitation by completing this addendum acknowledgment form. Check the box next to each addendum received and sign below. Failure to acknowledge addenda may result in bid disqualification.

Acknowledgment: I hereby acknowledge receipt of the following addenda and have made the necessary revisions to my proposal, plans and/or specification, etc.

Addendum Numbers Received:

(Check the box next to each addendum received)

- | | |
|--|--|
| <input checked="" type="checkbox"/> Addendum No. 1 | <input type="checkbox"/> Addendum No. 6 |
| <input type="checkbox"/> Addendum No. 2 | <input type="checkbox"/> Addendum No. 7 |
| <input type="checkbox"/> Addendum No. 3 | <input type="checkbox"/> Addendum No. 8 |
| <input type="checkbox"/> Addendum No. 4 | <input type="checkbox"/> Addendum No. 9 |
| <input type="checkbox"/> Addendum No. 5 | <input type="checkbox"/> Addendum No. 10 |

I understand that failure to confirm the receipt of addenda may be cause for rejection of this bid. I further understand that that any verbal representation made or assumed to be made during any oral discussion held between Vendor's representatives and any state personnel is not binding. Only the information issued in writing and added to the specifications by an official addendum is binding.

STATE EQUIPMENT, INC.

Company



Authorized Signature

5/31/17

Date

NOTE: This addendum acknowledgement should be submitted with the bid to expedite document processing.

--

Item Number	Estimated Quantity	Unit of Measure	Description	Unit Price	Total
1	20	Each	One complete unit: Batwing Rotary Mower w/ 3-Point Hitch	\$15,947.00 -	\$318,940.00 -

Vendor shall list the year, make, and model of the unit being bid:

Year: 2017

Make: LAND PRIDE

Model: RC5616 SERIES 2

Vendor: STATE EQUIPMENT, INC.

Contact Name: EDDIE ROWAN, JR.

Contact Phone: (304)776-4405

Contact Email: EDDIE@STATEEQUIPMENT.COM

DESIGNATED CONTACT: Vendor appoints the individual identified in this Section as the Contract Administrator and the initial point of contact for matters relating to this Contract.

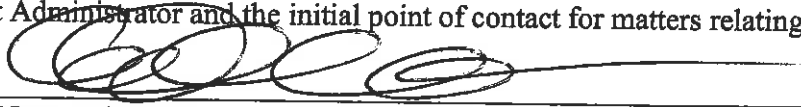

(Name, Title)
EDDIE ROWAN, JR GENERAL MANAGER

(Printed Name and Title)
P.O. BOX 3939 CHARLESTON, WV 25339

(Address)
(304)776-4405 (304)776-4409

(Phone Number) / (Fax Number)
EDDIE@STATEEQUIPMENT.COM

(email address)

CERTIFICATION AND SIGNATURE: By signing below, or submitting documentation through wvOASIS, I certify that I have reviewed this Solicitation in its entirety; that I understand the requirements, terms and conditions, and other information contained herein; that this bid, offer or proposal constitutes an offer to the State that cannot be unilaterally withdrawn; that the product or service proposed meets the mandatory requirements contained in the Solicitation for that product or service, unless otherwise stated herein; that the Vendor accepts the terms and conditions contained in the Solicitation, unless otherwise stated herein; that I am submitting this bid, offer or proposal for review and consideration; that I am authorized by the vendor to execute and submit this bid, offer, or proposal, or any documents related thereto on vendor's behalf; that I am authorized to bind the vendor in a contractual relationship; and that to the best of my knowledge, the vendor has properly registered with any State agency that may require registration.

STATE EQUIPMENT, INC.

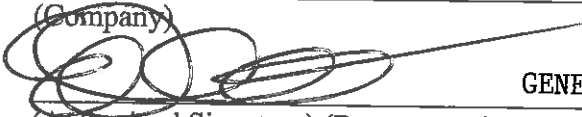
(Company)

GENERAL MANAGER
(Authorized Signature) (Representative Name, Title)
EDDIE ROWAN, JR. GENERAL MANAGER

(Printed Name and Title of Authorized Representative)
5/31/17

(Date)
(304)776-4405 (304)776-4409

(Phone Number) (Fax Number)

CRFQ 0803 DOT1700000082
REQUEST FOR QUOTATION
CLASS 135 BATWING STYLE ROTARY MOWER W/3 POINT
HITCH - TRACTOR ATTACHMENT

7. MISCELLANEOUS:

7.1 No Substitutions: Vendor shall supply only Contract Items submitted in response to RFQ unless a contract modification is approved in accordance with the provisions contained in this contract.

7.2 Reports: Vendor shall provide quarterly reports and annual summaries to the Agency showing the Agency's items purchased, quantities of items purchased, and total dollar value of the items purchased. Vendor shall also provide reports, upon request, showing the items purchased during the term of this Contract, the quantity purchased for each of those items, and the total value of purchases for each of those items. Failure to supply such reports may be grounds for cancellation of this Contract.

7.3 Contract Manager: During its performance of this Contract, Vendor must designate and maintain a primary contract manager responsible for overseeing Vendor's responsibilities under this Contract. The Contract manager must be available during normal business hours to address any customer service or other issues related to this Contract. Vendor should list its Contract manager and his or her contact information below.

Contract Manager: EDDIE ROWAN, JR
Telephone Number: (304)776-4405
Fax Number: (304)776-4409
Email Address: EDDIE@STATEEQUIPMENT.COM

7.4 Operating and Service Manuals and Parts Lists: An operator's manual must be included with each unit upon delivery. A "line sheet" (if applicable) and the "Equipment Preventative Maintenance Questionnaire", (Exhibit "B") must be with pilot unit upon delivery, Attn: Marcia Lee. There must be 12 service/shop/maintenance manuals and 14 parts manuals; CD-ROM is preferred in lieu of parts manuals. Manuals shall be delivered upon completion of delivery of total units. Failure to do so will delay payment.

7.5 Training: Manufacturers and/or dealers will be required to stage a thorough seminar on the subjects of Preventative Maintenance, Operator, and Mechanic Training. In order to keep operators and mechanics updated, the successful vendor shall conduct training sessions covering the operation, maintenance, troubleshooting with each purchase order against this open end contract. Manufacturers and/or dealers shall be required to furnish the Training Academy with one (1) Operator's Manual to be shipped direct to

State of West Virginia

VENDOR PREFERENCE CERTIFICATE

Certification and application is hereby made for Preference in accordance with **West Virginia Code**, §5A-3-37. (Does not apply to construction contracts). **West Virginia Code**, §5A-3-37, provides an opportunity for qualifying vendors to request (at the time of bid) preference for their residency status. Such preference is an evaluation method only and will be applied only to the cost bid in accordance with the **West Virginia Code**. This certificate for application is to be used to request such preference. The Purchasing Division will make the determination of the Vendor Preference, if applicable.

1. **Application is made for 2.5% vendor preference for the reason checked:**
 Bidder is an individual resident vendor and has resided continuously in West Virginia for four (4) years immediately preceding the date of this certification; **or**,
 Bidder is a partnership, association or corporation resident vendor and has maintained its headquarters or principal place of business continuously in West Virginia for four (4) years immediately preceding the date of this certification;
 Bidder is a resident vendor partnership, association, or corporation with at least eighty percent of ownership interest of bidder held by another entity that meets the applicable four year residency requirement; **or**,
 Bidder is a nonresident vendor which has an affiliate or subsidiary which employs a minimum of one hundred state residents and which has maintained its headquarters or principal place of business within West Virginia continuously for the four (4) years immediately preceding the date of this certification; **or**,
2. **Application is made for 2.5% vendor preference for the reason checked:**
 Bidder is a resident vendor who certifies that, during the life of the contract, on average at least 75% of the employees working on the project being bid are residents of West Virginia who have resided in the state continuously for the two years immediately preceding submission of this bid; **or**,
3. **Application is made for 2.5% vendor preference for the reason checked:**
 Bidder is a nonresident vendor that employs a minimum of one hundred state residents, or a nonresident vendor which has an affiliate or subsidiary which maintains its headquarters or principal place of business within West Virginia and employs a minimum of one hundred state residents, and for purposes of producing or distributing the commodities or completing the project which is the subject of the bidder's bid and continuously over the entire term of the project, on average at least seventy-five percent of the bidder's employees or the bidder's affiliate's or subsidiary's employees are residents of West Virginia who have resided in the state continuously for the two immediately preceding years and the vendor's bid; **or**,
4. **Application is made for 5% vendor preference for the reason checked:**
 Bidder meets either the requirement of both subdivisions (1) and (2) or subdivision (1) and (3) as stated above; **or**,
5. **Application is made for 3.5% vendor preference who is a veteran for the reason checked:**
 Bidder is an individual resident vendor who is a veteran of the United States armed forces, the reserves or the National Guard and has resided in West Virginia continuously for the four years immediately preceding the date on which the bid is submitted; **or**,
6. **Application is made for 3.5% vendor preference who is a veteran for the reason checked:**
 Bidder is a resident vendor who is a veteran of the United States armed forces, the reserves or the National Guard, if, for purposes of producing or distributing the commodities or completing the project which is the subject of the vendor's bid and continuously over the entire term of the project, on average at least seventy-five percent of the vendor's employees are residents of West Virginia who have resided in the state continuously for the two immediately preceding years.
7. **Application is made for preference as a non-resident small, women- and minority-owned business, in accordance with West Virginia Code §5A-3-59 and West Virginia Code of State Rules.**
 Bidder has been or expects to be approved prior to contract award by the Purchasing Division as a certified small, women- and minority-owned business.

Bidder understands if the Secretary of Revenue determines that a Bidder receiving preference has failed to continue to meet the requirements for such preference, the Secretary may order the Director of Purchasing to: (a) rescind the contract or purchase order; or (b) assess a penalty against such Bidder in an amount not to exceed 5% of the bid amount and that such penalty will be paid to the contracting agency or deducted from any unpaid balance on the contract or purchase order.

By submission of this certificate, Bidder agrees to disclose any reasonably requested information to the Purchasing Division and authorizes the Department of Revenue to disclose to the Director of Purchasing appropriate information verifying that Bidder has paid the required business taxes, provided that such information does not contain the amounts of taxes paid nor any other information deemed by the Tax Commissioner to be confidential.

Bidder hereby certifies that this certificate is true and accurate in all respects; and that if a contract is issued to Bidder and if anything contained within this certificate changes during the term of the contract, Bidder will notify the Purchasing Division in writing immediately.

Bidder: STATE EQUIPMENT, INC.

Signed: 

Date: 5/31/17

Title: GENERAL MANAGER

*Check any combination of preference consideration(s) indicated above, which you are entitled to receive.

STATE OF WEST VIRGINIA
Purchasing Division

PURCHASING AFFIDAVIT

MANDATE: Under W. Va. Code §5A-3-10a, no contract or renewal of any contract may be awarded by the state or any of its political subdivisions to any vendor or prospective vendor when the vendor or prospective vendor or a related party to the vendor or prospective vendor is a debtor and: (1) the debt owed is an amount greater than one thousand dollars in the aggregate; or (2) the debtor is in employer default.

EXCEPTION: The prohibition listed above does not apply where a vendor has contested any tax administered pursuant to chapter eleven of the W. Va. Code, workers' compensation premium, permit fee or environmental fee or assessment and the matter has not become final or where the vendor has entered into a payment plan or agreement and the vendor is not in default of any of the provisions of such plan or agreement.

DEFINITIONS:

"Debt" means any assessment, premium, penalty, fine, tax or other amount of money owed to the state or any of its political subdivisions because of a judgment, fine, permit violation, license assessment, defaulted workers' compensation premium, penalty or other assessment presently delinquent or due and required to be paid to the state or any of its political subdivisions, including any interest or additional penalties accrued thereon.

"Employer default" means having an outstanding balance or liability to the old fund or to the uninsured employers' fund or being in policy default, as defined in W. Va. Code § 23-2c-2, failure to maintain mandatory workers' compensation coverage, or failure to fully meet its obligations as a workers' compensation self-insured employer. An employer is not in employer default if it has entered into a repayment agreement with the Insurance Commissioner and remains in compliance with the obligations under the repayment agreement.

"Related party" means a party, whether an individual, corporation, partnership, association, limited liability company or any other form or business association or other entity whatsoever, related to any vendor by blood, marriage, ownership or contract through which the party has a relationship of ownership or other interest with the vendor so that the party will actually or by effect receive or control a portion of the benefit, profit or other consideration from performance of a vendor contract with the party receiving an amount that meets or exceeds five percent of the total contract amount.

AFFIRMATION: By signing this form, the vendor's authorized signer affirms and acknowledges under penalty of law for false swearing (W. Va. Code §61-5-3) that neither vendor nor any related party owe a debt as defined above and that neither vendor nor any related party are in employer default as defined above, unless the debt or employer default is permitted under the exception above.

WITNESS THE FOLLOWING SIGNATURE:

Vendor's Name: STATE EQUIPMENT, INC.

Authorized Signature: [Handwritten Signature] Date: 5/31/17

State of WEST VIRGINIA

County of KANAWHA, to-wit:

Taken, subscribed, and sworn to before me this 31st day of May, 2017.

My Commission expires March 27, 2021.

AFFIX SEAL HERE

NOTARY PUBLIC Marie Eiler

Purchasing Affidavit (Revised 08/01/2015)

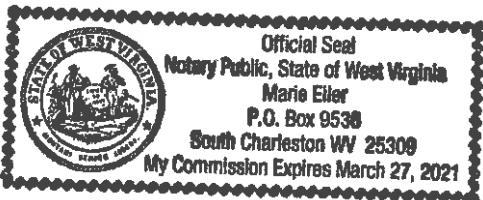

CRFQ 0803DOT 1700000082

Class 135 BATWING STYLE ROTARY MOWER

Exceptions to Bid

3.1.2 Cutting Capacity

3.1.2.2 Cutting heights from 1 inch to 14 inches, cutting heights for most all mowing applications and transport heights to clear objects while operating. Some applications require mowing lower to 1" height while operating to full height of 14"

3.1.7 Hydraulics

3.1.8.1 Hydraulic wing lift without spring assist, wings will fold down without the need for spring assist to unfold functioning properly

3.1.8 Wheels and suspension

3.1.9.1 Aircraft tire size of 25.5"x8"x14". This tire is a new tire with a slightly different dimension that will offer the same carrying capacity of the specified tire on bid

3.1.9.2 Steel spring axle cushion for 4 pair of tires offering little maintenance over the life of unit. Spring steel will need no adjustment or maintenance to maintain cutting heights compared to air cushions which will need maintenance to maintain even cutting heights over the life of the unit. Spring steel axle will provide shock absorption for each of the 4 sets of tires. Mowing applications can be in areas that have sharp objects that could come in contact with the rubber air cushion that can cause damage or failure of the air cushion. Steel will not be damaged by these same sharp objects.

RC5615 15' FOLDING ROTARY CUTTER

HP
50-250

HITCH
Pull-Type

Smooth top and bottom design.

Land Pride's 56 Series, 15 foot cutter is smooth on top, which allows debris and moisture to roll off or be easily swept or blown off. And its smooth on bottom, which means less chance of dry caking material getting lodged in tight corners, which again, means less time for cleaning.

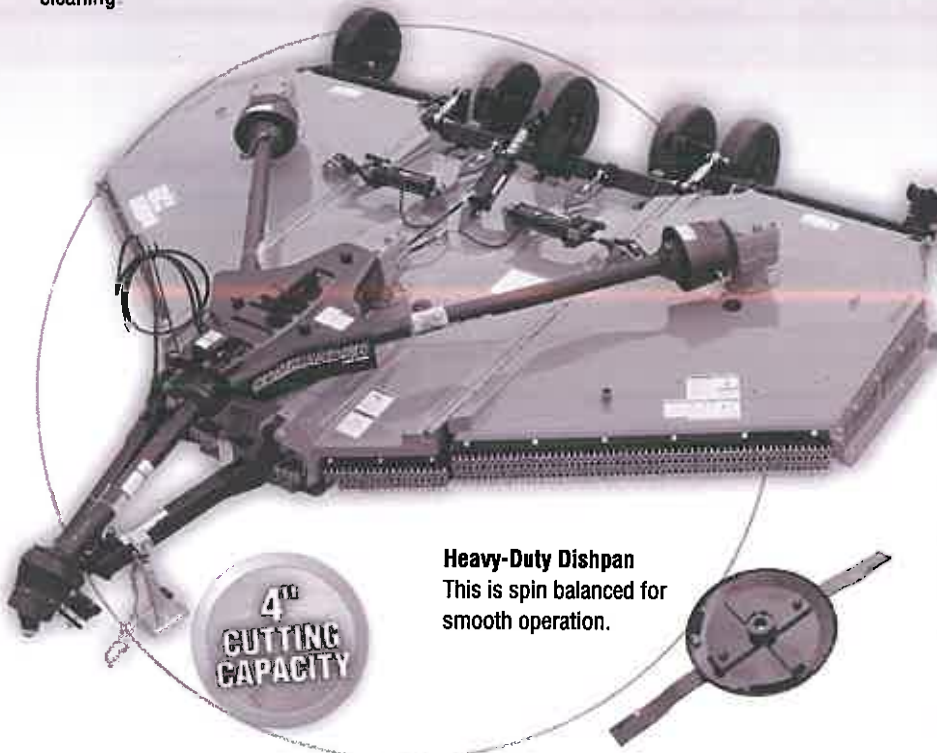

Heavy-Duty Dishpan
This is spin balanced for smooth operation.

- 9' 1" Transport Width
- Smooth top and bottom design
- Replaceable 1/4" side skirts with replaceable skid shoes
- High blade tip speed

COMMANDER
Series 2



RC5615 HEAVY DUTY	
Horsepower	50-250 HP
Hitch	Pull-Type, Standard Clevis, LP Performance Self-Leveling, Pintle, Ball, Bar-Tite
Working Width (cm)	15' (457)
Overall Width	15' 8"
Min. Transport Width	9' 1"
Overall Length	16'
Machine Weight - lb (kg)	5,446 (2470)
Cutting Height	2" - 14"
Cutting Capacity	4"
Tongue Weight - lb	2,080
Deck Thickness	7 Gauge Bottom, 10 Gauge Top
Deck Height	12"
Deck Shock Protection	Independent Wheel Arm Springs
Side Thickness	1/4" Replaceable
Safety Guards (must choose)	Front & Rear: Single or Double Chain or Rubber Guard
Skid Shoes	Wings and Center, Replaceable
Blades	1/2" x 4" Heat Treated Free Swinging Alloy Steel w/Uplift
Blade Bolt	Keyed with Hardened Flatwasher & Lock Nut
Blade Overlap	6"
Blade Tip Speed (Feet per minute)	540 RPM: 16,300 fpm on Center, 16,300 fpm on Wings; 1000 RPM: 16,300 fpm on Center, 16,000 fpm on Wings
Dishpan	3/16", Round, Dish Shaped with 1" x 5" Blade Bar
Hydraulics	Wings: 3" x 8" Cylinder, Hoses and Fittings; Axles: 3-1/2" x 8"
Gearbox Rating [^]	540 or 1000 RPM: 250 HP Divider, 210 HP Center & Wings
Gearbox Output Shaft	2-3/8"
Gearbox Input Shaft	1-3/4" 20 spline
Input Driveline	Cat. 6 CV
Connecting Drivelines	Choice of Cat. 4 or Cat. 5 Driveline Slip-Clutch
Max. Turning Angle	80° with Constant Velocity U-Joint
Tires - 6 or 8	21" Laminated 29" Used Aircraft 25.5" Foam-Filled

*See dealer for complete warranty information.

[^]Based on field performance.

Color Options:

7 YEAR
Limited Powertrain
Warranty

Land Pride

CUTTERS



RC(M)5615 & RC(M)6615 Series 2

Specifications & Capacities		
Model Numbers	RC5615 & RCM5615	RC6615 & RCM6615
Horsepower Range	50 to 250	
Gearbox Horsepower	250 HP Splitter 210 HP Center & Wing	250 HP Splitter 210 HP Center & Wing (Blade spindle gearboxes are built heavier)
Gear Box Lubrication	Gear Lube 80-90W EP	
Gearbox Oil Capacity	5.5 Pints: Divider Gearbox 10 Pints: Center deck, LH deck & RH deck spindle gearboxes	
Cutting Capacity	4"	4 1/2"
Tongue Weight	1,860 lbs.	
Machine Weight	Single row chain guards, 6 aircraft wheels, 540 CV main driveline & standard clevis hitch	
	5,446 lbs.	5,660 lbs.
Blade Tip Speed	Center Blades = 16,300 FPM Center Blades = 16,300 FPM	Wing Blades = 16,300 FPM Wing Blades = 16,000 FPM
At 540 RPM		
At 1000 RPM		
Hitch Types	Optional Self-Leveling Clevis Hitch, LP Performance Hitch, Bar-Tite Hitch, Pintle Hitch, or Ball Hitch	
Hitch Jack	Standard (7,000 lbs.)	
Cutting Width	15' - 0"	
Overall Width	15' - 11 3/4"	
Normal Transport Width	9'-1"	
Minimum Transport Width	7'-6" With transport locks & deflectors removed and cylinders fully retracted	
Overall Length	16' - 0"	
Deck Height	12"	
Cutting Height	2" to 14"	
Lift Hydraulics	3 1/2" x 8" hydraulic cylinder, hoses, fittings & stroke control spacers	
Wing Hydraulics	3" x 8" hydraulic cylinders, hoses & fittings	
Wing Transport Protection	Wing transport lock pins	
Deck Material	10 gauge top deck and 7 gauge bottom deck	
Side Skirt Material	Bolt-on replaceable 1/4" steel	
Skid Shoes	Reversible & Replaceable: 2 straight skid shoes and 2 AR400 leading skid shoes. Replaceable: 2 skid shoes	
Wing Deck		
Center Deck		
Blades - 6 (2 per Carrier)	1/2" x 4" Heat Treated Free Swinging Alloy Steel with up lift	
Blade Overlap	6"	
Blade Bolt	Keyed with hardened flat washer & lock nut	
Stump Jumper / Blade Holder	3/16" Thick round dish-shaped pan, reinforced with 1" x 5" blade bar; or optional Shredder Kit	
Deck Ring	Optional 1/2" x 3" fully welded	
Front & Rear Guards	Optional rubber, single chain, double chain, or double chain with cable	
Input Driveline 540 & 1000 rpm	Cat. 6 with constant velocity u-joint or Cat. 5 with conventional (non-cv) u-joint	
Intermediate Driveline	Category 5 star profile with slip-clutch	
Wing Drivelines	Category 4 star profile with slip-clutch or optional Cat. 5 w/slip clutch	Category 5 star profile with slip-clutch
Tire Options	6" x 21" Laminated tires, 25.5" new tire with or without foam fill, 29" x 16 ply used aircraft tires without foam filling.	
Number of Wheels	6 - Wheel option: 4 on transport axle and one on each wing axle 8 - Wheel option: 4 on transport axle and two on each wing axle	
Transport Axle	Spring-cushioned on trailing arms	
Hubs	Cast iron five-bolt hubs with tapered roller bearings and 1 3/4" shafts	
Colors	Standard color: Beige; Optional colors: Red, Green, Orange, or Yellow	

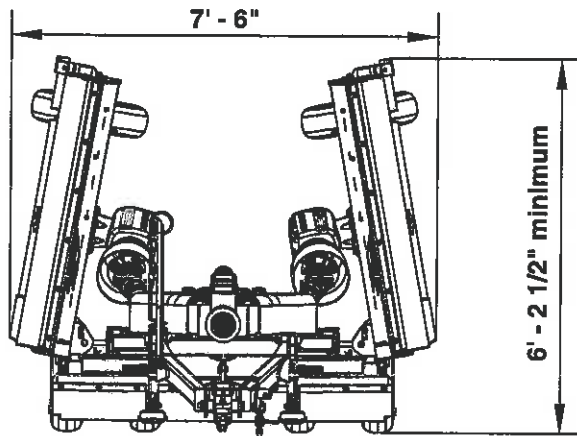

Transport Width
With Transport Locks &
Deflectors Removed And
Cylinders Fully Retracted

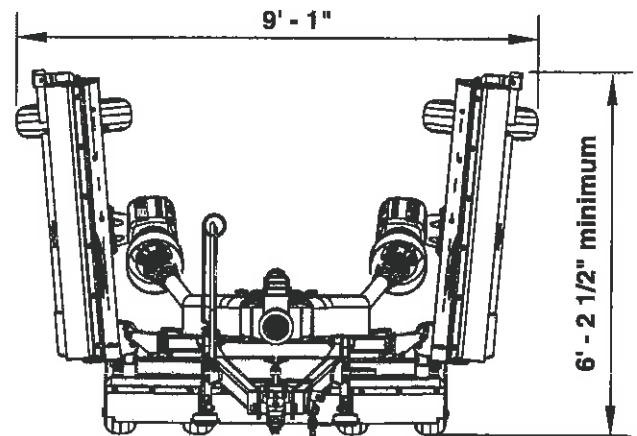

Transport Width
Without Special Adjustments.
Cylinders Are Fully Retracted.

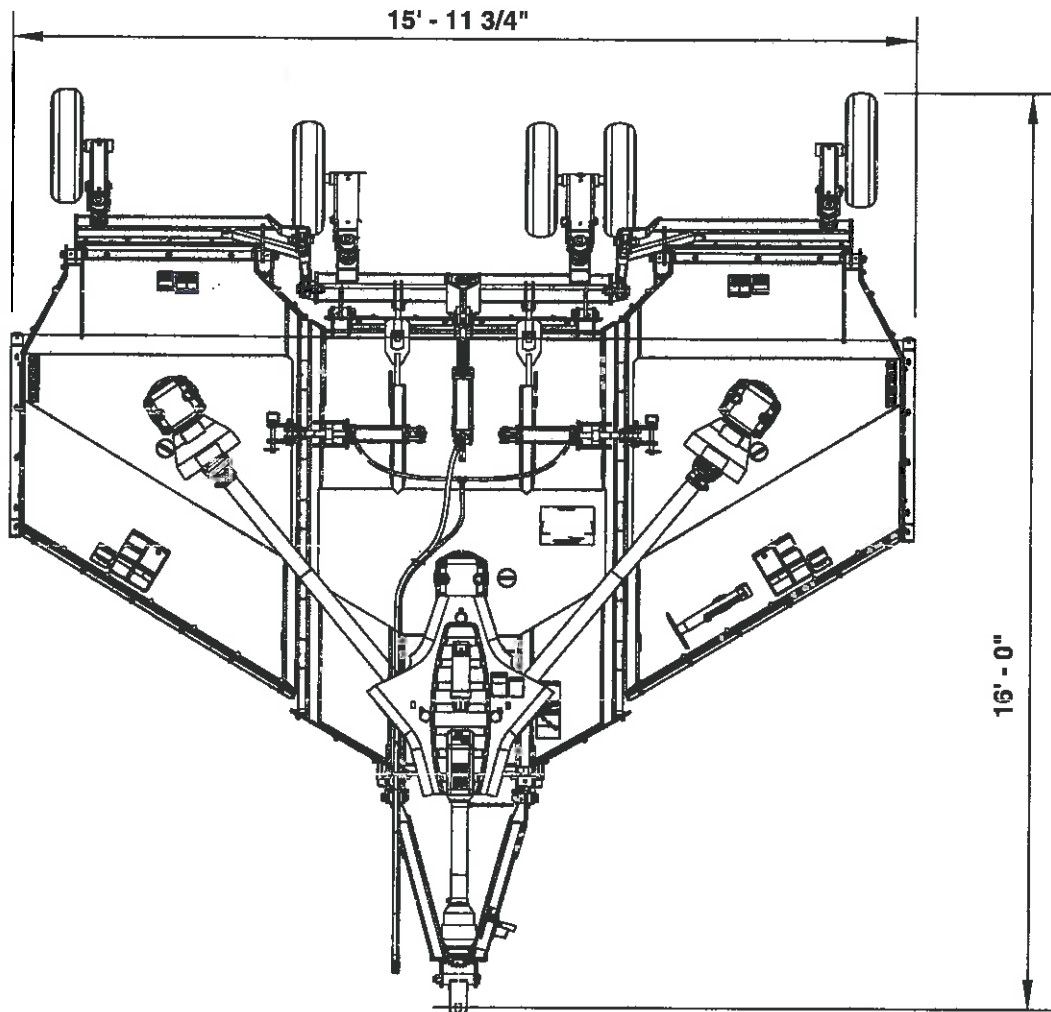

Dimensions shown are with center hydraulic cylinder fully extended and 24 x 7.75 aircraft tires

26670

RC(M)5615 & RC(M)6615 Series 2

Features	Benefits
Surpassed rugged industry standards	All Land Pride Cutters have been designed and tested to meet rigorous voluntary testing procedures according to ISO 4254-13.
Factory assembled	Saves customer set-up time and money.
7 Year gearbox warranty	Shows confidence in gearbox integrity. (Years 6 & 7, parts only.)
Rugged heavy built gearboxes	Capable of handling heavy cutting applications.
Gearbox Seal Protection	Gearbox bottom seal protection for longer bearing life.
2 3/8" Output gearbox shaft	Large output shaft handles shock loads better.
2 Piece shield on wing gearboxes	Driveline grease zerks are easier to access.
Self-leveling hitches	Reduces drawbar wear by keeping hitch level while going through ditches.
Low hitch weight on tractor tongue	Ideal for smaller HP tractors by reducing the amount of weight on the drawbar.
Narrow A-frame hitch	Allows for a tighter turning radius.
Adjustable park jack angle	Park jack can be adjusted to be perpendicular to the ground.
Adjustable driveline hanger	Serves as a support rest for the driveline when the cutter is unhooked from the tractor. Assist operator when attaching driveline to tractor PTO shaft.
Input driveline: Cat. 6 CV or Cat. 5 Conventional	Holds up to shock loads and harsh mowing conditions. Constant velocity (CV) U-joint allows for 80 degree turns without doing damage to the driveline.
Drivelines with slip-clutches: RC56 Series: Cat. 4 standard RC66 Series: Cat. 5 standard	Driveline is sized right for the intended cutting capacity. Slip-clutches will slip under load to minimize twist damage to driveline profiles.
Grease zerks on end caps of driveline cross journals	Intermediate and wing driveline cross journals are easier to grease. All drivelines have access holes for greasing the U-joints and inner profiles.
High blade tip speed	Allows clean cutting of material and even distribution.
6" Blade overlap	Eliminates skipping during turns.
High cutting capacity	Can cut brushy areas with saplings up to 4" with 56 Series and 4 1/2" with 66 Series.
Pre-cut chamber	Allows grass and vegetation to stand back up prior to cutting for a more complete cut.
Reinforced leading deck edges	Front of deck can withstand heavy brush and saplings.
12" Deck height	Handles heavy cutting, which reduces balling-up of cut material under the deck.
10 Gauge smooth deck top	Reduces accumulation of debris and is easier and faster to clean.
7 Gauge smooth deck bottom	Heavy deck design holds up to harsh conditions. No bottom obstructions.
Replaceable 1/4" side skirt	Reduces debris piercing possibilities. Can be replaced if damaged.
Left wing rotates clockwise	Better discharge of material. Picks up tractor tracks.
3/16" Stump jumper backed with a 1" thick mounting bar	Heavy round stump jumper. Can hold up to tough conditions.
Beveled skid shoes on wings	Reduces gouging the ground when turning.
Hinged wing sections	Allows cutter to follow terrain. Ideal for rough ground where hillsides, ditches, and hollows can cause uneven cutting.
Greasable wing folding hinges	Provides for a long hinge life and allows wings to fold up and down with less stress.
1" Solid hinge rods	Gives greater strength to the cutter from front to rear, and in the hinge area itself.
Wing transport locks	Holds transport wings in the folded-up position in case of hydraulic pressure loss.
Collapsible 1" leveling rods	Prevents damage and failure to leveling rods. Large diameter leveling rods provide superior supporting strength over rough terrain.
Enclosed dual leveling rods	Cutter pulls equally on the rear axle while traveling over rough terrain.
5-Bolt hubs on trailing arms	5-Bolt hubs makes the wheel assembly more durable and longer lasting.
Drain holes in wheel rims	Allows water to drain from wheels mounted on folded-up wings. Helps prevent paint deterioration and rusting to the wheel rims.
Spring-cushioned trailing arms	Provides independent suspension, cushions loads on drawbar.
Replaceable wheel spindles	Wheel spindles can be replaced when damaged without replacing the entire axle. Simply remove one bolt to replace damaged spindle.
Wheel options	Laminated tires: Eliminates flats. Air-filled tires: Give better cushion while transporting. Foam-filled tires: Give better cushion while transporting and can't go flat.
LP Performance hitch option	Great for uneven terrain, reduces drawbar wear. Hitch pivots freely up and down and pivots about the tractor drawbar.
Bar-tite hitch option	Ideal for extreme conditions. Clamps tight to drawbar eliminating drawbar wear.
Roadway light kit option	Allows operator to transport on public roads safer when head lights are turned on and/or when flasher lights are turned on.
Deck ring option	Keeps blades from damaging the deck.