



Purchasing Division
 2019 Washington Street East
 Post Office Box 50130
 Charleston, WV 25305-0130

State of West Virginia
 Request for Quotation
 13 - Equipment

Proc Folder: 302507

Doc Description: ADDENDUM_2: CLASS 934 UNDER BRIDGE INSPECTION VEHICLE

Proc Type: Central Purchase Order

Date Issued	Solicitation Closes	Solicitation No	Version
2017-05-10	2017-05-17 13:30:00	CRFQ 0803 DOT1700000075	3

BID RECEIVING LOCATION

BID CLERK

DEPARTMENT OF ADMINISTRATION
 PURCHASING DIVISION
 2019 WASHINGTON ST E
 CHARLESTON
 US

WV 25305

VENDOR

Vendor Name, Address and Telephone Number:

Matheny Motors
 4125 1st Ave
 Nitro WV 25143
 304-769-5860 X 3601

05/16/17 15:04:57
 WV Purchasing Division

FOR INFORMATION CONTACT THE BUYER

Mark A Atkins
 (304) 558-2307
 mark.a.atkins@wv.gov

Signature X

FEIN # 55-032-0770

DATE 5/15/2017

All offers subject to all terms and conditions contained in this solicitation

ADDITIONAL INFORMATION:

ADDENDUM 2: Is issued for the following:

1. Change the bid opening date from 05/11/2017 to 05/17/2017 @ 1:30pm EST.
2. Publish the Technical Questions received by vendors with the Agency responses.

NO OTHER CHANGES

The West Virginia Purchasing Division is soliciting bids on behalf of the West Virginia Division of Highways (WVDOH), Department of Transportation (DOT), to establish a contract for the one-time purchase of a Class 934 Underbridge Inspection Vehicle per attached documents.

Mandatory Pre-Bid Meeting will be held on April 19, 2017 at 10:00am EST at the following location:

WV Division of Highways
 Bldg. 5
 Room A-855 (Training Room)
 1900 Kanawha Blvd East
 Charleston, WV 25305

INVOICE TO	SHIP TO
DIVISION OF HIGHWAYS EQUIPMENT DIVISION RT 33 83 BRUSHY ROAD CROSSING, PO BOX 610 BUCKHANNON WV26201 US	DIVISION OF HIGHWAYS EQUIPMENT DIVISION 83 BRUSHY FORK RD CROSSING BUCKHANNON WV 26201 US

Line	Comm Ln Desc	Qty	Unit Issue	Unit Price	Total Price
1	CLASS 934 UNDER BRIDGE INSPECTION VEHICLE	1.00000	EA	\$787,284.00	\$787,284.00

Comm Code	Manufacturer	Specification	Model #
24101514	Freightliner	2018	122 SD Twin Steer with Aspen Aerial A-75

Extended Description :

ONE COMPLETE UNIT: UNDER BRIDGE INSPECTION VEHICLE

Vendor should complete and submit Exhibit A Pricing Page with bid.

SCHEDULE OF EVENTS

Line	Event	Event Date
1	Mandatory Pre-Bid Meeting:	2017-04-19
2	Technical Questions due by:	2017-04-24

DOT1700000075	Document Phase Final	Document Description ADDENDUM_2: CLASS 934 UNDER BRIDGE INSPECTION VEHICLE	Page 3 of 3
----------------------	--------------------------------	---	-----------------------

ADDITIONAL TERMS AND CONDITIONS

See attached document(s) for additional Terms and Conditions

CRFQ 0803 DOT1700000075
EXHIBIT_A

Pricing Sheet

Item Number	Estimated Quantity	Unit of Measure	Description	Unit Price	Total
1	1	Each	One complete unit: Under Bridge Inspection Vehicle	\$ 787,284.00	\$ 787,284.00
				Grand Total	\$ 787,284.00

Vendor shall list the year, make, and model of the unit being bid:

Year: 2018

Make: Freightliner

Model: 122SD

ADDENDUM ACKNOWLEDGEMENT FORM
SOLICITATION NO.: CRFO 0803 DOT1700000075

Instructions: Please acknowledge receipt of all addenda issued with this solicitation by completing this addendum acknowledgment form. Check the box next to each addendum received and sign below. Failure to acknowledge addenda may result in bid disqualification.

Acknowledgment: I hereby acknowledge receipt of the following addenda and have made the necessary revisions to my proposal, plans and/or specification, etc.

Addendum Numbers Received:

(Check the box next to each addendum received)

- | | |
|--|--|
| <input checked="" type="checkbox"/> Addendum No. 1 | <input type="checkbox"/> Addendum No. 6 |
| <input checked="" type="checkbox"/> Addendum No. 2 | <input type="checkbox"/> Addendum No. 7 |
| <input type="checkbox"/> Addendum No. 3 | <input type="checkbox"/> Addendum No. 8 |
| <input type="checkbox"/> Addendum No. 4 | <input type="checkbox"/> Addendum No. 9 |
| <input type="checkbox"/> Addendum No. 5 | <input type="checkbox"/> Addendum No. 10 |

I understand that failure to confirm the receipt of addenda may be cause for rejection of this bid. I further understand that that any verbal representation made or assumed to be made during any oral discussion held between Vendor's representatives and any state personnel is not binding. Only the information issued in writing and added to the specifications by an official addendum is binding.

Matheny Motors

Company

Authorized Signature

May 15, 2017

Date

NOTE: This addendum acknowledgement should be submitted with the bid to expedite document processing.

CRFQ 0803 DOT 1700000075
Request For Quotation
UNDERBRIDGE INSPECTION VEHICLE

6.5 Condition of Unit upon Delivery: All units must arrive at the prescribed delivery point having been completely pre-serviced with oil, lubricants, and coolant. All prescribed precautions pertaining to first operations and break-in of the unit are to be posted conspicuously on the unit for ready observance by the operator.

7. MISCELLANEOUS:

7.1 No Substitutions: Vendor shall supply only Contract Items submitted in Response to the Solicitation unless a contract modification is approved in accordance with the provisions contained in this Contract.

7.2 Contract Manager: During its performance of this Contract, Vendor must designate and maintain a primary contract manager responsible for overseeing Vendor's responsibilities under this Contract. The Contract manager must be available during normal business hours to address any customer service or other issues related to this Contract. Vendor should list its Contract manager and his or her contact information below.

Contract Manager: Jack Cummings
Telephone Number: 304-769-5860 x 3601
Fax Number: 304-769-5866
Email Address: jcummings@mathenymotors.com

7.3 Operating and Service Manuals and Parts Lists: An operator's manual must be included with each unit upon delivery. A "line sheet" (if applicable) and the "Equipment Preventive Maintenance Questionnaire", (**Exhibit B**) must be with unit Upon delivery, Attn: Marcia Lee. There must be three (3) service/shop/maintenance manuals and 3 parts manuals; CD-ROM is preferred in lieu of parts manuals. Manuals shall be delivered upon completion of delivery of total units. Failure to do so will delay payment.

7.4 Training: Manufacturers and/or contractors will be required to stage a thorough seminar on the subjects of Preventative Maintenance, Operator, and Mechanic Training. In order to keep operators and mechanics updated, the successful vendor shall conduct training sessions covering the operation, maintenance, trouble- shooting with this purchase order. Manufacturers and/or vendors shall be required to furnish the Training Academy with one (1) Operator's Manual to be shipped direct to

WVDOH
Training Academy
P.O. Box 610
Buckhannon, West Virginia 26201

DESIGNATED CONTACT: Vendor appoints the individual identified in this Section as the Contract Administrator and the initial point of contact for matters relating to this Contract.

Jack Cummings - Sales Consultant

(Name, Title)

Jack Cummings - Sales Consultant

(Printed Name and Title)

4125 1st Ave Nitro WV 25143

(Address)

304-769-5860 x 3601 and 304-769-5866

(Phone Number) / (Fax Number)

jcummings@mathenymotors.com

(email address)

CERTIFICATION AND SIGNATURE: By signing below, or submitting documentation through wvOASIS, I certify that I have reviewed this Solicitation in its entirety; that I understand the requirements, terms and conditions, and other information contained herein; that this bid, offer or proposal constitutes an offer to the State that cannot be unilaterally withdrawn; that the product or service proposed meets the mandatory requirements contained in the Solicitation for that product or service, unless otherwise stated herein; that the Vendor accepts the terms and conditions contained in the Solicitation, unless otherwise stated herein; that I am submitting this bid, offer or proposal for review and consideration; that I am authorized by the vendor to execute and submit this bid, offer, or proposal, or any documents related thereto on vendor's behalf; that I am authorized to bind the vendor in a contractual relationship; and that to the best of my knowledge, the vendor has properly registered with any State agency that may require registration.

Matheny Motors

(Company)

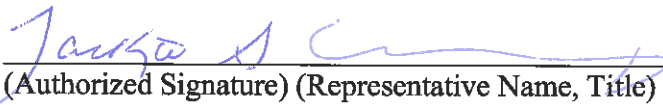

Sales Consultant

(Authorized Signature) (Representative Name, Title)

Jack Cummings - Sales Consultant

(Printed Name and Title of Authorized Representative)

May 15th 2017

(Date)

304-769-5860 x 3601 and 304-769-5866

(Phone Number) (Fax Number)

State of West Virginia

VENDOR PREFERENCE CERTIFICATE

Certification and application is hereby made for Preference in accordance with West Virginia Code, §5A-3-37. (Does not apply to construction contracts). West Virginia Code, §5A-3-37, provides an opportunity for qualifying vendors to request (at the time of bid) preference for their residency status. Such preference is an evaluation method only and will be applied only to the cost bid in accordance with the West Virginia Code. This certificate for application is to be used to request such preference. The Purchasing Division will make the determination of the Vendor Preference, if applicable.

- 1. Application is made for 2.5% vendor preference for the reason checked: Bidder is an individual resident vendor and has resided continuously in West Virginia for four (4) years immediately preceding the date of this certification; or, Bidder is a partnership, association or corporation resident vendor and has maintained its headquarters or principal place of business continuously in West Virginia for four (4) years immediately preceding the date of this certification; Bidder is a resident vendor partnership, association, or corporation with at least eighty percent of ownership interest of bidder held by another entity that meets the applicable four year residency requirement; or, Bidder is a nonresident vendor which has an affiliate or subsidiary which employs a minimum of one hundred state residents and which has maintained its headquarters or principal place of business within West Virginia continuously for the four (4) years immediately preceding the date of this certification; or,
2. Application is made for 2.5% vendor preference for the reason checked: Bidder is a resident vendor who certifies that, during the life of the contract, on average at least 75% of the employees working on the project being bid are residents of West Virginia who have resided in the state continuously for the two years immediately preceding submission of this bid; or,
3. Application is made for 2.5% vendor preference for the reason checked: Bidder is a nonresident vendor that employs a minimum of one hundred state residents, or a nonresident vendor which has an affiliate or subsidiary which maintains its headquarters or principal place of business within West Virginia and employs a minimum of one hundred state residents, and for purposes of producing or distributing the commodities or completing the project which is the subject of the bidder's bid and continuously over the entire term of the project, on average at least seventy-five percent of the bidder's employees or the bidder's affiliate's or subsidiary's employees are residents of West Virginia who have resided in the state continuously for the two immediately preceding years and the vendor's bid; or,
4. Application is made for 5% vendor preference for the reason checked: Bidder meets either the requirement of both subdivisions (1) and (2) or subdivision (1) and (3) as stated above; or,
5. Application is made for 3.5% vendor preference who is a veteran for the reason checked: Bidder is an individual resident vendor who is a veteran of the United States armed forces, the reserves or the National Guard and has resided in West Virginia continuously for the four years immediately preceding the date on which the bid is submitted; or,
6. Application is made for 3.5% vendor preference who is a veteran for the reason checked: Bidder is a resident vendor who is a veteran of the United States armed forces, the reserves or the National Guard, if, for purposes of producing or distributing the commodities or completing the project which is the subject of the vendor's bid and continuously over the entire term of the project, on average at least seventy-five percent of the vendor's employees are residents of West Virginia who have resided in the state continuously for the two immediately preceding years.
7. Application is made for preference as a non-resident small, women- and minority-owned business, in accordance with West Virginia Code §5A-3-59 and West Virginia Code of State Rules. Bidder has been or expects to be approved prior to contract award by the Purchasing Division as a certified small, women- and minority-owned business.

Bidder understands if the Secretary of Revenue determines that a Bidder receiving preference has failed to continue to meet the requirements for such preference, the Secretary may order the Director of Purchasing to: (a) rescind the contract or purchase order; or (b) assess a penalty against such Bidder in an amount not to exceed 5% of the bid amount and that such penalty will be paid to the contracting agency or deducted from any unpaid balance on the contract or purchase order.

By submission of this certificate, Bidder agrees to disclose any reasonably requested information to the Purchasing Division and authorizes the Department of Revenue to disclose to the Director of Purchasing appropriate information verifying that Bidder has paid the required business taxes, provided that such information does not contain the amounts of taxes paid nor any other information deemed by the Tax Commissioner to be confidential.

Bidder hereby certifies that this certificate is true and accurate in all respects; and that if a contract is issued to Bidder and if anything contained within this certificate changes during the term of the contract, Bidder will notify the Purchasing Division in writing immediately.

Bidder: Matheny Motors

Signed: [Signature]

Date: May 9, 2017

Title: Sales Consultant

*Check any combination of preference consideration(s) indicated above, which you are entitled to receive.

STATE OF WEST VIRGINIA
Purchasing Division

PURCHASING AFFIDAVIT

MANDATE: Under W. Va. Code §5A-3-10a, no contract or renewal of any contract may be awarded by the state or any of its political subdivisions to any vendor or prospective vendor when the vendor or prospective vendor or a related party to the vendor or prospective vendor is a debtor and: (1) the debt owed is an amount greater than one thousand dollars in the aggregate; or (2) the debtor is in employer default.

EXCEPTION: The prohibition listed above does not apply where a vendor has contested any tax administered pursuant to chapter eleven of the W. Va. Code, workers' compensation premium, permit fee or environmental fee or assessment and the matter has not become final or where the vendor has entered into a payment plan or agreement and the vendor is not in default of any of the provisions of such plan or agreement.

DEFINITIONS:

"Debt" means any assessment, premium, penalty, fine, tax or other amount of money owed to the state or any of its political subdivisions because of a judgment, fine, permit violation, license assessment, defaulted workers' compensation premium, penalty or other assessment presently delinquent or due and required to be paid to the state or any of its political subdivisions, including any interest or additional penalties accrued thereon.

"Employer default" means having an outstanding balance or liability to the old fund or to the uninsured employers' fund or being in policy default, as defined in W. Va. Code § 23-2c-2, failure to maintain mandatory workers' compensation coverage, or failure to fully meet its obligations as a workers' compensation self-insured employer. An employer is not in employer default if it has entered into a repayment agreement with the Insurance Commissioner and remains in compliance with the obligations under the repayment agreement.

"Related party" means a party, whether an individual, corporation, partnership, association, limited liability company or any other form or business association or other entity whatsoever, related to any vendor by blood, marriage, ownership or contract through which the party has a relationship of ownership or other interest with the vendor so that the party will actually or by effect receive or control a portion of the benefit, profit or other consideration from performance of a vendor contract with the party receiving an amount that meets or exceed five percent of the total contract amount.

AFFIRMATION: By signing this form, the vendor's authorized signer affirms and acknowledges under penalty of law for false swearing (W. Va. Code §61-5-3) that neither vendor nor any related party owe a debt as defined above and that neither vendor nor any related party are in employer default as defined above, unless the debt or employer default is permitted under the exception above.

WITNESS THE FOLLOWING SIGNATURE:

Vendor's Name: Matheny Motors

Authorized Signature: *[Handwritten Signature]* Date: May 15, 2017

State of WV

County of Kanawha, to-wit:

Taken, subscribed, and sworn to before me this 15th day of May, 2017.

My Commission expires December 25, 2018.

AFFIX SEAL HERE

NOTARY PUBLIC *[Handwritten Signature]*

Purchasing Affidavit (Revised 08/01/2015)

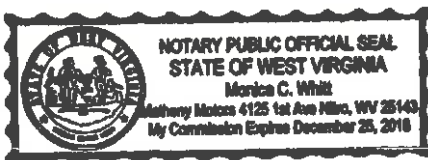

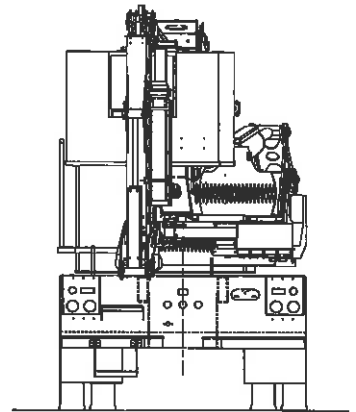
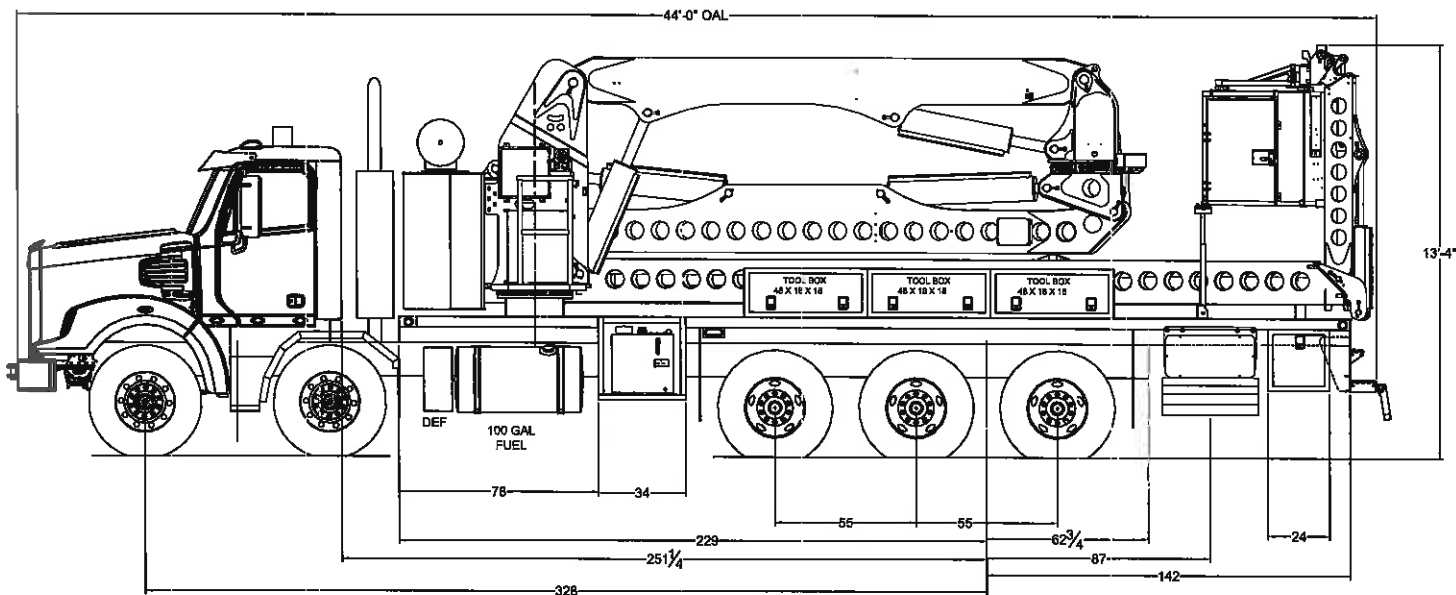
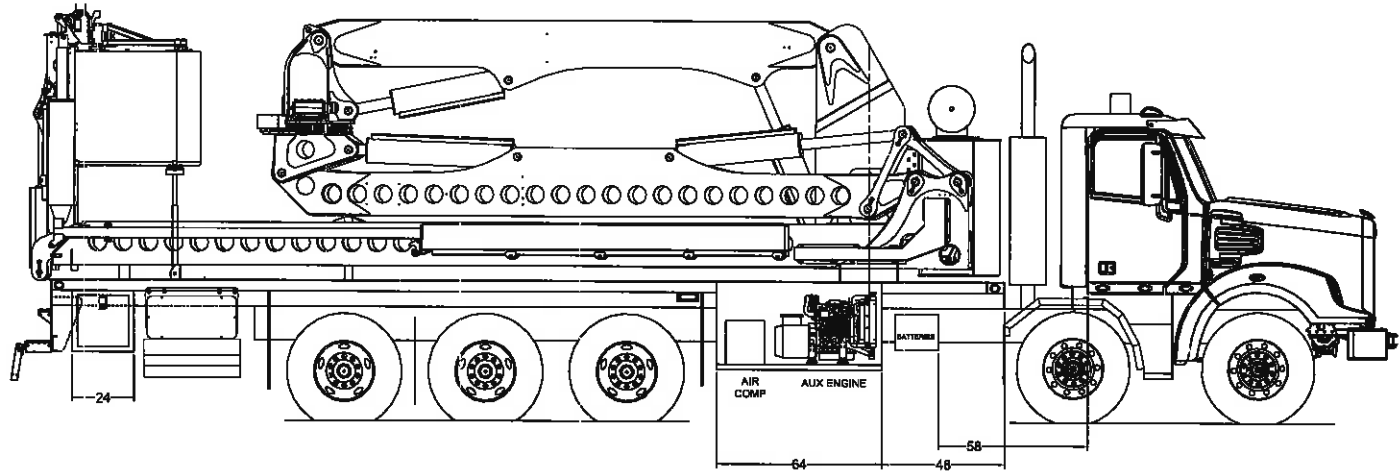

CHASSIS: FREIGHTLINER 122SD

ESTIMATED FRONT AXLE WEIGHT 15,600 LB ESTIMATED SECOND AXLE WEIGHT 15,600 LB TOTAL WEIGHT 78,200 LB ESTIMATED LIFT AXLE WEIGHT 12,000 LB ESTIMATED DRIVE AXLE WEIGHT 17,500 LB ESTIMATED DRIVE AXLE WEIGHT 17,500 LB

DO NOT SCALE THIS DRAWING		ASPEN AERIALS INC. <small>2000 TERRY AVE. SUITE 100 - MARTIN, KY 40154</small>	
<small>UNLESS OTHERWISE SPECIFIED DIMENSIONS ARE IN INCHES DECIMALS ARE FRACTIONS & ARE SHOWN TO THE RIGHT OF A DECIMAL POINT UNLESS OTHERWISE SPECIFIED DIMENSIONS IN PARENTHESIS ARE HOLE SIZES</small>		GENERAL ARRANGEMENT A75WEST VIRGINIA	
REV	REVISION	DATE	BY
	NEW RELEASE AUTHORIZED	4/20/12	
<small>DATE: 12/13/11 TIME: 10:00 AM</small>		SCALE	DRAWN BY
	1/1	B	A75 WV



MATHENY MOTOR TRUCK CO.

Established 1922

3rd & Ann Streets • P.O. Box 1304

Parkersburg, WV 26102

(304) 485-4418 • (304) 485-2577 fax

www.mathenymotors.com

WARRANTY CLARIFICATION RFQ 0803 DOT1700000075

2018 Freightliner 122 SD

Please see enclosed "New Vehicle Warranty Coverage"

Allison Automatic Transmission 4500 RDS

3 years of total coverage

Please see enclosed "2016 Allison Transmission Coverage"

DD13 Engine

Please see enclosed "Detroit Engine" Brochure

2 Years of Virtual Technician also included

Aspen Aerial Unit

1 year warranty

PONTIAC BUICK

GMC

↕ SUZUKI



Freightliner (FTL)



Run Smart™

Freightliner Level III (Factory released on or after 1/07/2013)

Category Determinants	
Road Surface — most severe in-transit between sites	Any
GCW	All Okay
Axles and Their Manufacturer's GVW Rating	
2-axle unit	Over 49,000 lb/21 000 kg
3-axle unit	Over 69,000 lb/31 000 kg
4-axle unit	Over 89,000 lb/40 000 kg
5-axles or more	Over 98,000 lb/44 452 kg

Coverage ¹		
Description	Time ²	Distance ²
Basic Vehicle	1 Year	50,000 mi/80 500 km
Battery	1 Year	50,000 mi/80 500 km
Brightwork	6 Months	Unlimited
Cab Corrosion/Perforation	1 Year	50,000 mi/80 500 km
Cab Structure	1 Year	50,000 mi/80 500 km
Corrosion	6 Months	Unlimited
Crossmembers	1 Year	50,000 mi/80 500 km
Diesel Emission 2010 ³	5 Years	100,000 mi/161 000 km
Frame Rails	1 Year	50,000 mi/80 500 km
GHG14 ⁴ (Medium Heavy Duty to Heavy Heavy Duty Trucks)	5 Years	100,000 mi/161 000 km
GHG14 ⁴ (Medium Heavy Duty to Heavy Heavy Duty Tractors)	5 Years	100,000 mi/161 000 km
GHG14 ⁴ Tire	2 Years	24,000 mi/38 400 km
Paint	1 Year	50,000 mi/80 500 km
Paint, Chassis	6 Months	Unlimited
Front Axle ⁵	1 Year	100,000 mi/161 000 km
Rear Axle	1 Year	100,000 mi/161 000 km
Transfer Case	1 Year	100,000 mi/161 000 km
Transmission	1 Year	100,000 mi/161 000 km
Detroit Front Axle ⁶ (File Direct)		
Pre-Model Year 2011 ⁶	1 Year	100,000 mi/161 000 km
Post-Model Year 2011 ⁷	1 Year	Unlimited
Post-Model Year 2011 ⁸	3 Years	300,000 mi/483 000 km
Post-Model Year 2011 ⁹	2 Years	Unlimited
Detroit Rear Axle (File Direct)		
Pre-Model Year 2011 ⁶	1 Year	100,000 mi/161 000 km
Post-Model Year 2011 ⁷	1 Year	Unlimited
Post-Model Year 2011 ⁸	3 Years	300,000 mi/483 000 km

Warranty Statement & Warranty Coverage Descriptions follow on page five of this document.

The information provided in this document is for general information only and is not offered as customer's warranty.

This coverage may be superseded without notification.

Copyright © Daimler Trucks North America LLC. All rights reserved. Daimler Trucks North America LLC is a Daimler company.

Post-Model Year 2011 ⁹	2 Years	Unlimited
-----------------------------------	---------	-----------

- ¹Coverage may vary; check vehicle's actual warranty coverage online via OWL's *Coverage Info/Check Coverage* screen.
- ²Time or distance, whichever comes first
- ³Applies to vehicles equipped with EPA 2010 compliant diesel engines.
- ⁴Applies to models 2013 and later domiciled in the United States, check actual warranty online via OWL's *Coverage Info/Check Coverage* screen for coverage listed as "GHG14...".
- ⁵Front Axle coverage is also applicable to gliders.
- ⁶Pre-Model Year 2011 Detroit Axle: Warranty coverage is determined by Gross Combination Weight Rating, road surface, and vocation. Please see www.ddcsn.com for specific coverage details.
- ⁷Other – Severe Duty: Warranty coverage is determined by Gross Combination Weight Rating, road surface, and vocation. Please see www.ddcsn.com for specific coverage details.
- ⁸Heavy Duty – General Service: Warranty coverage is determined by Gross Combination Weight Rating, road surface, and vocation. Please see www.ddcsn.com for specific coverage details.
- ⁹Medium Duty – General Service: Warranty coverage is determined by Gross Combination Weight Rating, road surface, and vocation. Please see www.ddcsn.com for specific coverage details.

Warranty Statement & Warranty Coverage Descriptions follow on page five of this document.

The information provided in this document is for general information only and is not offered as customer's warranty.

This coverage may be superseded without notification.

Copyright © Daimler Trucks North America LLC. All rights reserved. Daimler Trucks North America LLC is a Daimler company.

Freightliner (FTL)



Run Smart

Freightliner Level III (Factory released prior to 1/07/2013)

Category Determinants	
Road Surface – most severe in-transit between sites	Any
GCW	All Okay
Axles and Their Manufacturer's GVW Rating	
2-axle unit	Over 46,000 lb/20 865 kg
3-axle unit	Over 66,000 lb/29 937 kg
4-axle unit	Over 86,000 lb/39 008 kg
5-axles or more	Over 98,000 lb/44 452 kg

Coverage ¹		
Description	Time ²	Distance ²
Basic Vehicle	1 Year	50,000 mi/80 500 km
Battery	1 Year	50,000 mi/80 500 km
Brightwork	6 Months	Unlimited
Cab Corrosion/Perforation	1 Year	50,000 mi/80 500 km
Cab Structure	1 Year	50,000 mi/80 500 km
Corrosion	6 Months	Unlimited
Crossmembers	1 Year	50,000 mi/80 500 km
Diesel Emission 2010 ³	5 Years	100,000 mi/161 000 km
Frame Rails	1 Year	50,000 mi/80 500 km
GHG14 ⁴ (Medium Heavy Duty to Heavy Heavy Duty Trucks)	5 Years	100,000 mi/161 000 km
GHG14 ⁴ (Medium Heavy Duty to Heavy Heavy Duty Tractors)	5 Years	100,000 mi/161 000 km
GHG14 ⁴ Tire	2 Years	24,000 mi/38 400 km
Paint	1 Year	50,000 mi/80 500 km
Paint, Chassis	6 Months	Unlimited
Front Axle ⁵	1 Year	100,000 mi/161 000 km
Rear Axle	1 Year	100,000 mi/161 000 km
Transfer Case	1 Year	100,000 mi/161 000 km
Transmission	1 Year	100,000 mi/161 000 km
Detroit Front Axle ⁵ (File Direct)		
Pre-Model Year 2011 ⁶	1 Year	100,000 mi/161 000 km
Post-Model Year 2011 ⁷	1 Year	Unlimited
Post-Model Year 2011 ⁸	3 Years	300,000 mi/483 000 km
Post-Model Year 2011 ⁹	2 Years	Unlimited
Detroit Rear Axle (File Direct)		
Pre-Model Year 2011 ⁶	1 Year	100,000 mi/161 000 km
Post-Model Year 2011 ⁷	1 Year	Unlimited
Post-Model Year 2011 ⁸	3 Years	300,000 mi/483 000 km

Warranty Statement & Warranty Coverage Descriptions follow on page five of this document.

The information provided in this document is for general information only and is not offered as customer's warranty.

This coverage may be superseded without notification.

Copyright © Daimler Trucks North America LLC. All rights reserved. Daimler Trucks North America LLC is a Daimler company.

Post-Model Year 2011⁸	2 Years	Unlimited
---	----------------	------------------

¹Coverage may vary; check vehicle's actual warranty coverage online via OWL's *Coverage Info/Check Coverage* screen.
²Time or distance, whichever comes first
³Applies to vehicles equipped with EPA 2010 compliant diesel engines.
⁴Applies to models 2013 and later domiciled in the United States, check actual warranty online via OWL's *Coverage Info/Check Coverage* screen for coverage listed as "GHG14..."
⁵Front Axle coverage is also applicable to gliders.
⁶Pre-Model Year 2011 Detroit Axle: Warranty coverage is determined by Gross Combination Weight Rating, road surface, and vocation. Please see www.ddcsn.com for specific coverage details.
⁷Other – Severe Duty: Warranty coverage is determined by Gross Combination Weight Rating, road surface, and vocation. Please see www.ddcsn.com for specific coverage details.
⁸Heavy Duty – General Service: Warranty coverage is determined by Gross Combination Weight Rating, road surface, and vocation. Please see www.ddcsn.com for specific coverage details.
⁹Medium Duty – General Service: Warranty coverage is determined by Gross Combination Weight Rating, road surface, and vocation. Please see www.ddcsn.com for specific coverage details.

Warranty Statement & Warranty Coverage Descriptions follow on page five of this document.

The information provided in this document is for general information only and is not offered as customer's warranty.

This coverage may be superseded without notification.

Copyright © Daimler Trucks North America LLC. All rights reserved. Daimler Trucks North America LLC is a Daimler company.

Warranty Statement

1.1 New Vehicle Coverage

The following section outlines Company standard warranty coverages for all Company vehicles, apparatus or chassis or cabs sold by Daimler Trucks North America and domiciled in the USA (50 states and Washington, D.C.) and Canada. This information is also included in the Owner's Warranty Information Booklet.

See Warranty Coverage Descriptions for standard warranty coverages by make and model. Additional coverage may apply, verify actual coverages with your local dealership for specific vehicle warranty.

1.2 New Vehicle Limited Warranty

Under this New Vehicle Limited Warranty ("Warranty"), Company warrants that each new vehicle will be free from defects in material and workmanship that occur under normal use within the applicable warranty period, subject to certain limitations and exclusions as specified in this document.

This limited warranty applies only to new vehicles sold by an authorized Daimler Trucks North America (DTNA) dealer or ordered directly from DTNA; vehicles sold at auction or as a result of repossession retain the warranty coverage from the original in-service date or factory invoice date if the vehicle has not been warranty registered.

Daimler Trucks North America LLC reserves the right to reduce or remove coverage on vehicles in salvage condition.

This Warranty covers all components and parts unless specifically covered by other warranties or otherwise excluded by this document.

1.3 Limitations

This Warranty does not apply to vehicles that are sold or domiciled outside of the United States (50 states and Washington, D.C.) or Canada.

This Warranty does not apply to engines, Allison transmissions, tires, or other components or parts that are not manufactured by Company and that are warranted directly by their respective manufacturers. Progressive damage caused by these manufacturers' components to any other parts including, but not limited to, parts installed by Company is excluded from Company warranty coverage. With respect to the foregoing, Company makes no warranty whether express, implied, statutory or otherwise including, but not limited to, any warranty of merchantability or fitness for a particular purpose.

THIS WARRANTY IS EXCLUSIVE AND IN LIEU OF ALL OTHER WARRANTIES OF ANY KIND WHETHER WRITTEN, ORAL, OR IMPLIED INCLUDING, BUT NOT LIMITED TO ANY WARRANTY OF MERCHANTABILITY OR FITNESS FOR A PARTICULAR PURPOSE. THIS WARRANTY SPECIFICALLY EXCLUDES ANY OTHER

WARRANTIES OR CONDITIONS PROVIDED FOR BY LAW, WHETHER STATUTORY OR OTHERWISE.

COMPANY'S SOLE OBLIGATION UNDER THIS WARRANTY SHALL BE TO REPAIR OR REPLACE, IN COMPANY'S SOLE DISCRETION, ANY DEFECTIVE COMPONENT OR PART. SUCH REPAIR OR REPLACEMENT SHALL BE WITHOUT COST TO PURCHASER WHEN PERFORMED WITHIN THE APPLICABLE WARRANTY PERIOD (TIME, DISTANCE, OR HOUR LIMIT, WHICHEVER OCCURS FIRST).

Purchaser must notify Company within the applicable warranty period, of any failure of the vehicle to comply with this Warranty and Purchaser must, at Purchaser's expense, promptly return the vehicle to an Authorized Service Facility for inspection and repair or replacement of any defect in material or workmanship occurring within the applicable warranty period. During New Vehicle coverage, warranty reimbursement will not be paid on repairs performed by customers on their own vehicles without a current Customer Performed Warranty Agreement (CPWA).

The vehicle must be maintained and serviced according to the prescribed schedules outlined in the Driver's/Operator's and Maintenance Manuals. Receipted bills and other evidence that required maintenance and service have been performed are required by Company as a condition of this Warranty.

After the Company's obligations under this Warranty expire, all liabilities of Company to Purchaser under this Warranty shall terminate. Repairs made under this Warranty do not constitute an extension of the original Warranty period for the vehicle or for any specific component or part.

To the extent that any provision of this Warranty contravenes the law of any jurisdiction, such provision shall be inapplicable in such jurisdiction, and the remainder of the warranty shall not be affected.

1.4 Purchaser's Exclusive Remedy

THIS WARRANTY SHALL BE THE PURCHASER'S SOLE AND EXCLUSIVE REMEDY AGAINST COMPANY, WHETHER IN CONTRACT, UNDER STATUTE (INCLUDING STATUTORY PROVISIONS AS TO CONDITIONS AS TO QUALITY OR FITNESS FOR ANY PARTICULAR PURPOSE OF GOODS SUPPLIED PURSUANT TO THE CONTRACT OF SALE), WARRANTY, TORT, STRICT LIABILITY, OR ANY OTHER LEGAL THEORY.

1.5 Limitation of Liability

COMPANY'S LIABILITY UNDER THIS WARRANTY IS LIMITED TO THE COST TO REPAIR OR REPLACE, IN COMPANY'S SOLE DISCRETION, THE DEFECTIVE COMPONENT OR PART THAT IN NO EVENT SHALL EXCEED THE FAIR MARKET VALUE OF THE VEHICLE AT THE TIME THE DEFECT IS DISCOVERED.

IN NO EVENT SHALL COMPANY BE LIABLE FOR SPECIAL, INDIRECT, INCIDENTAL, OR CONSEQUENTIAL DAMAGES INCLUDING, BUT NOT LIMITED TO, INJURIES TO PERSONS OR DAMAGE

TO PROPERTY, LOSS OF PROFITS OR ANTICIPATED PROFITS, OR LOSS OF VEHICLE USE.

1.6 Exclusions

The following components, parts, or conditions are specifically excluded from coverage under this Warranty.

AERODYNAMIC WHEEL COVERS

Aerodynamic wheel covers are excluded from coverage under this Warranty

AIR SPRINGS

Tolerance buildup can occur during the assembly process of the rear suspension and rear cab air springs, and can cause the springs to have the appearance of being crooked, misaligned or improperly installed. This tolerance buildup is not detrimental to the operation of the vehicle and will not have an effect on either the quality of the ride or the durability of the components or vehicle. Straightening of these springs is not covered under this Warranty.

ALIGNMENT OF AXLES/WHEELS/STEERING

Each DTNA vehicle manufacturing plant uses an integrated alignment system to align axles and wheels and to center the steering wheel to Daimler Trucks North America LLC specifications. Realignment or readjustment of these items, including steering stops and steering poppets, is not covered under warranty.

Any special alignment settings at the request of the Owner must be handled between the Dealer and Owner after delivery from factory. These special adjustments are not covered under Warranty.

AXLE BREATHER VENTS

During the vehicle manufacturing process, an oil run or drip stain may appear at the breather vent. Removing the vent, applying pipe sealant to the threaded vent fitting and re-installing the vent is unnecessary. Removing the axle breather vent and re-sealing the threaded fitting is not covered under this Warranty.

CAB INTERIOR COMPONENTS

The repair or replacement of cab interior components that are rendered unserviceable due to normal wear or abuse are not covered under this Warranty.

These components include, but are not limited to:

- Curtains
- Floor coverings (including floor mats)
- Painted trim components
- Steering wheel
- Steering wheel wrap
- Upholstery
- Window shades

CHROME SURFACES, ALUMINUM AND STAINLESS STEEL COMPONENTS

The following items ARE covered under this Warranty:

- Chrome peeling off in sheets
- Chrome cut at mounting bolts due to over-torque at the factory
- Bubbles in the chrome that are not caused by rock chips and/or general rust conditions
- Isolated rust along seams or welds

The following items are NOT covered under this Warranty:

- General rust, for example, rust on the unfinished backside of a bumper
- Dimpling at the mounting bolts
- Staining, bluing, and/or yellowing that can be cleaned with a quality cleaning-product
- Rust, pits, and/or nicks caused by road wash or road debris breaking the chrome surface
- Streaks/stains/corrosion caused by severe wash solutions or corrosive road salts/chemicals

Claims pertaining to failures of chrome surfaces, aluminum, and stainless steel components will not be processed unless a clear digital picture is provided that adequately shows the defect.

CLUTCH ADJUSTMENT

Clutch adjustments are normally required due to clutch wear and are considered normal maintenance. However, if the clutch adjustment is found to be outside of Company specifications during, or prior to, in-service of the vehicle, a warranty claim will be accepted on a one-time basis.

Claims for clutch adjustments will not be accepted unless the adjustment is found to be outside of Company specifications using the special clutch adjustment measuring tools provided by Company (e.g., adjusting the clutch to satisfy feel will not be accepted as warranty).

COMPETITION

Warranty will become void on any vehicle that is used in competition, including but not limited to:

- Racing
- Tractor pulls
- Other motor sports

CONSUMABLE PARTS

Parts that are subject to consumption during their normal service life and are routinely replaced during normal maintenance services are covered up to 15,000 miles (24 000km) for all Daimler Trucks North America LLC vehicles except for Thomas Built Bus (TBB) bodies and chassis. TBB consumable parts are covered up to 30 days from date of in-service.

These items are:

- Antennas
- Ashtrays
- Belts
- Brake Linings
- Cigarette lighter assembly
- Clutch brake
- Clutch linings
- Data logger batteries
- Desiccant cartridges
- Fire extinguishers
- Fluorescent ballast and tubes
- Fuses
- Gladhand
- Hosetennas
- Light bulbs
- Mattresses
- Mud flaps
- Mud flap mounting brackets
- Caps (including, but not limited to, DEF, fuel, radiator, surge tank)
- Receiver-dryer filter
- Trailer air hoses
- Trailer electrical cables

- Windshield washer nozzles
- Wiper arms and blades (TBB makes – wiper blades only)

Consumable parts NOT covered under this Warranty include, but are not limited to, the following:

- Antifreeze
- Filters (fuel, air, oil, water)
- Fluids (unless low due to a warrantable failure)
- Lubricant

CORROSION

A detailed list of exclusions for CORROSION is listed under Warranty Coverage Descriptions.

DAMAGE

The following are not covered under this Warranty:

- Damage caused by use of the vehicle in any application that is not approved or is inconsistent with build specifications
- Damage resulting from improper use or misuse or abuse, negligence, improper operation, improper or insufficient maintenance (including, but not limited to failure to maintain vehicle as outlined in the driver's/operator's and maintenance manuals), overloading, unauthorized modifications, accidents, or operation at excessive speeds
- Environmental damage, including airborne fallout (including chemicals, tree sap, etc.), or other atmospheric conditions, hailstones, or other acts of nature
- Damage caused by road salts/chemicals or cleaning solvents, detergents or compounds
- Storage deterioration including damage caused by improper or insufficient storage or maintenance
- Damage caused by road hazards or road conditions
- Damage caused during shipping/transport after initial delivery of vehicle
- Damages (including peeling or flaking) caused by high-pressure washing or steam-cleaning
- Damages occurring after in-service (e.g., from rock chips)
- Damages caused by customer-installed sealer in air conditioning systems
- Damages caused by engine horsepower/torque upgrades
- Damage due to vibration associated with misapplication or improper operation of drivetrain components
- Damage due to terrorist activities
- Damage due to acts of war

ENGINE

The engine, including all of its components as supplied by the engine manufacturer, is not covered under this Warranty, but is warranted separately by the manufacturer of the engine. For engine warranty or service, contact the engine manufacturer's authorized sales and service facility.

ENGINE BRAKES, AIR COMPRESSORS, AND OTHER PROPRIETARY ENGINE COMPONENTS

The engine manufacturer installs most air compressors and engine brakes. Any failure of a proprietary engine component or Jacob® Brake component must be filed directly to the engine manufacturer. Failures on non-proprietary engine components can be filed through DTNA.

EXHAUST SYSTEM CLAMPS

During the early life of the vehicle or when the engine is cold, many exhaust clamps exhibit a soot trace. This condition is self-correcting and does not require adjustment, tightening, or replacement of the clamp. Claims for adjusting or tightening will not be paid under warranty.

FIFTH WHEELS

Adjustment of the locking mechanism, bushings, slide locking plungers, and the repair or replacement of lock guards are considered routine maintenance and are not covered under this Warranty.

GLASS, MIRRORS, LENS

Glass, mirror, or lens breakage or chips or scratches of glass, mirrors, or lenses are not covered by this Warranty.

MISAPPLICATION OF VEHICLE

The warranty on any vehicle used inconsistent with its specified vocation/application will be downgraded to the warranty that is consistent with the vehicle use. Any and all claims associated with the misapplication of the vehicle will be subject to chargeback.

MISCELLANEOUS EXPENSES

Premium charges and work not directly related to the repair or replacement of a warranted part are not covered under this Warranty. Examples include, but are not limited to:

- Federal, state, provincial, and local taxes
- Travel expenses
- Loss of revenue
- Customer labor, including overtime labor
- Downtime
- Driver's expenses
- Cost of rental equipment
- Loss of cargo, including perishable cargo
- General housekeeping supplies (i.e., rags, solvents, sweeping compounds, coveralls, etc.)
- Communication charges
- Towing/road call assistance (unless coverage is specifically stated in the applicable warranty coverage table)
- Repair or replacement of optional items not sold or installed by company
- Removal or replacement of dealer, body builder, or customer installed equipment
- Environmental fees, cleanup, or other charges
- Cost of emergency services

MODIFICATIONS TO ORIGINAL EQUIPMENT

Company does not warrant vehicle component or chassis modifications, or equipment installations arranged by Dealers or Customers. In addition, the extra time necessary to remove body builder installed items and/or equipment to work on a warranted repair is not covered under this Warranty unless Company sells the complete chassis/body/equipment as a package.

If Dealers or Customers perform any vehicle modifications or equipment installations, to the extent these modifications or equipment installations adversely affect other vehicle components or vehicle performance, Company shall not accept any product liability or claims under the terms of the vehicle warranty. These claims become the sole responsibility of the person performing the modifications or equipment installations.

2016 Allison Transmission Coverage Pricing Guide II

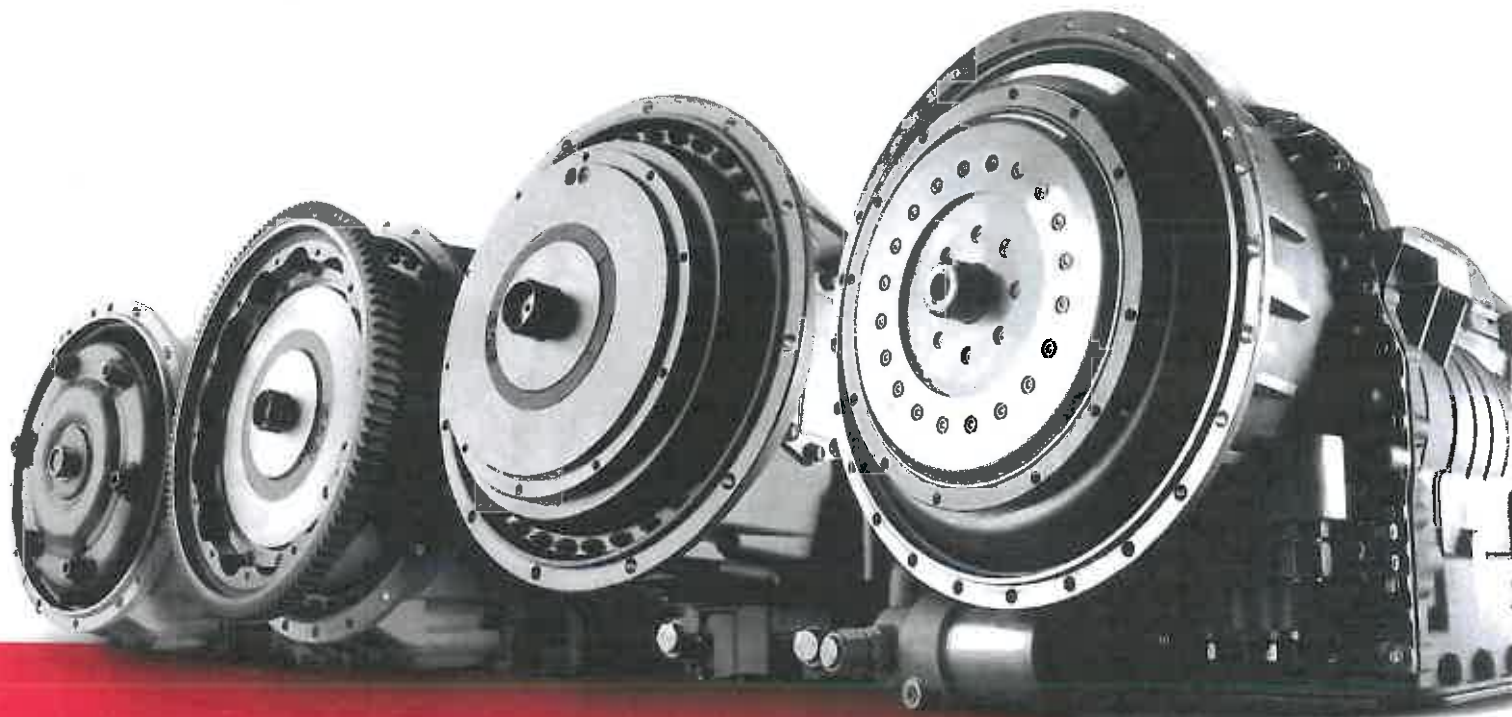

Improving The Way The World Works

Western Star Trucks \ Ldal \ Crane Carrier Company \ Kenworth \ Pierce
Volvo \ Mack \ Peterbilt \ Oshkosh \ Freightliner \ Freightliner Custom Chassis
Thomas Built Buses \ Blue Bird \ Hino \ International Truck & Engine \ IC Bus



Allison Transmission Coverage

Effective Dates

Transmission coverage effective dates as shown below are based upon individual agreements entered into between the OEM and Allison.

Navistar	Vehicles built on or after April 11, 2011.
Hino	Vehicles built on or after December 15, 2011.
American LaFrance	Vehicles built on or after January 1, 2012.

All other OEMs referenced on the cover of this guide are eligible to receive Partnership Coverage and Extended Transmission Coverage, so long as they meet the Extended Transmission Coverage requirements listed below.

NOTE: Stated prices are effective for Extended Transmission Coverage purchased in 2016.

Transmission Coverage Definitions And Requirements

Standard Limited Warranty

All Allison transmissions carry a comprehensive Standard Limited Warranty covering 100% parts and labor. The length of Standard Limited Warranty coverage depends upon the Vocational Model Series and vehicle vocation.

REQUIREMENTS: Use of Allison Approved TES 295[®] transmission fluid** and Genuine Allison Filters is required to be eligible for Partnership Transmission Coverage and Extended Transmission Coverage. Failure to use Allison Approved TES 295[®] transmission fluid and Genuine Allison Filters during the Standard Limited Warranty coverage period will result in no additional coverage options beyond Standard Limited Warranty.

Partnership Coverage

Some Allison-equipped vehicles purchased through Allison Partnerships carry Partnership Coverage. Partnership Coverage begins at the end of the Standard Limited Warranty period. Duration of Partnership Coverage varies depending upon the Vocational Model Series purchased.

REQUIREMENTS: Use of Allison Approved TES 295[®] transmission fluid and Genuine Allison Filters is required. Failure to use Allison Approved TES 295[®] transmission fluid and Genuine Allison Filters will result in no coverage for repairs beyond Standard Limited Warranty.

NOTE: Except as noted, all transmissions with Partnership Coverage beyond Standard Limited Warranty have 100% parts and labor coverage with no mileage limitations.

Extended Transmission Coverage***

In addition to Partnership Coverage, transmissions purchased through Allison Partnerships are eligible for Extended Transmission Coverage. Extended Transmission Coverage can be purchased on all models to increase coverage to a total of five years. Extended Transmission Coverage can be purchased on Highway Series, P&D/Beverage, to increase coverage to a total of seven years. Extended Transmission Coverage begins at the end of Partnership Coverage and is available for purchase through Allison Authorized Distributors and Dealers.

REQUIREMENTS: Use of Allison Approved TES 295[®] transmission fluid** and Genuine Allison Filters is required. Failure to use Allison Approved TES 295[®] transmission fluid and Genuine Allison Filters will result in no coverage for repair beyond the Standard Limited Warranty period. If the transmission is not OEM factory filled with Allison Approved TES 295[®] transmission fluid and Genuine Allison Filters, then Allison Approved TES 295[®] transmission fluid and Genuine Allison Filters must be installed at the time of Extended Transmission Coverage purchase. Transmissions not OEM factory filled with Allison Approved TES 295[®] transmission fluid, or transmissions operating with non-TES 295[®] fluids, must be drained and filled with Allison Approved TES 295[®] transmission fluid to achieve 100% concentration. One hundred percent concentration is not achieved until the second consecutive fluid change using Allison Approved TES 295[®] transmission fluid. The second consecutive change must be achieved at the time of Extended Transmission Coverage purchase.

* Suggested retail prices are established for each transmission vocational model/vocation combination. Prices and/or coverage are subject to change without notice. For current prices and coverage information, go to allisontransmission.com.

** For a list of current Allison Approved TES 295[®] transmission fluids, go to: allisontransmission.com; click on Parts + Service, then Approved Fluids.

*** The terms and conditions under which Allison Transmission offers Extended Transmission Coverage are set forth on the back of the Extended Transmission Coverage Agreement Registration, available from any authorized Allison Transmission Distributor or Dealer.

2016 Allison Transmission Coverage Pricing Guide II

RUGGED DUTY SERIES™		Total Coverage* (Included in acquisition price of transmission)	Extended Transmission Coverage Pricing** (Available for purchase)
Model	Vocation	Years of Coverage (Standard Limited Warranty** + Partnership Coverage)	2 Years
4000 RDSR	P&D and Beverage	2+1	\$1,098
	Refuse Packer	2+1	\$1,346
	Utility and Other	2+1	\$1,098
	Dump Trucks/Mixers	2+1	\$1,098
	Agriculture***	3+0	\$1,098
4500 RDS	P&D and Beverage	2+1	\$786
	Refuse Packer	2+1	\$1,001
	Utility and Other	2+1	\$786
	Dump Trucks/Mixers	2+1	\$786
	Agriculture***	3+0	\$786
4500 RDSR	P&D and Beverage	2+1	\$866
	Refuse Packer	2+1	\$1,096
	Utility and Other	2+1	\$866
	Dump Trucks/Mixers	2+1	\$866
	Agriculture***	3+0	\$866
4700 RDS	P&D and Beverage	N/A	N/A
	Refuse Packer	2+1	\$1,517
	Utility and Other	2+1	\$1,580
	Dump Trucks/Mixers	2+1	\$1,212
	Agriculture***	3+0	\$1,212
4700 RDSR	P&D and Beverage	N/A	N/A
	Refuse Packer	2+1	\$2,108
	Utility and Other	2+1	\$1,792
	Dump Trucks/Mixers	2+1	\$1,792
	Agriculture***	3+0	\$1,792

SPECIALTY SERIES™		Standard Limited Warranty	Extended Transmission Coverage*	Price
Model	Vocation	Years of Coverage	Years of Coverage	
1000 SP	Specialty/Military	2	3	\$474
1350 SP	Specialty/Military	2	3	\$474
2100 SP	Specialty/Military	2	3	\$536
2200 SP	Specialty/Military	2	3	\$536
2350 SP	Specialty/Military	2	3	\$576
2500 SP	Specialty/Military	2	3	\$474
2550 SP	Specialty/Military	2	3	\$474
3000 SP	Specialty/Military	2	3	\$382
3000 SPR	Specialty/Military	2	3	\$436
3200 SP	Specialty/Military	2	3	\$363
3200 SPR	Specialty/Military	2	3	\$371
3500 SP	Specialty/Military	2	3	\$253
3500 SPR	Specialty/Military	2	3	\$313
3700 SP*	Specialty/Military	N/A	N/A	N/A
3700 SPR*	Specialty/Military	N/A	N/A	N/A
4000 SP	Specialty/Military	2	3	\$385
4000 SPR	Specialty/Military	2	3	\$414
4500 SP	Specialty/Military	2	3	\$529
4500 SPR	Specialty/Military	2	3	\$499
4700 SP	Specialty/Military	2	3	\$654
4700 SPR	Specialty/Military	2	3	\$768
4800 SP	Specialty/Military	2	3	\$748
4800 SPR	Specialty/Military	2	3	\$977

* Models 3700SP and 3700SPR do not offer ETC.

* Total Coverage: Sum of Standard Limited Warranty and Partnership Coverage. Included in acquisition price of the transmission.

** Extended Transmission Coverage: Available for purchase through Allison Authorized Distributors and Dealers to increase coverage to a total of five years.

*** Hour limitations apply to Standard Limited Warranty. No hour limitations apply to Extended Transmission Coverage.

OIL FIELD SERIES™		Standard Limited Warranty	Extended Transmission Coverage*
Model	Vocation	Coverage	3 Years
3500 OFS	Oil Field	2 Years/3,000 hours	\$1,319
3500 OFSR	Oil Field	2 Years/3,000 hours	\$1,648
4500 OFS	Oil Field	2 Years/3,000 hours	\$1,981
4500 OFSR	Oil Field	2 Years/3,000 hours	\$2,418
4700 OFS	Oil Field	2 Years/3,000 hours	\$2,281
4700 OFSR	Oil Field	2 Years/3,000 hours	\$2,818
4750 OFS	Oil Field	2 Years/3,000 hours	\$2,497
4750 OFSR	Oil Field	2 Years/3,000 hours	\$3,238

Standard Limited Warranty and Extended Transmission Coverage provide coverage up to a total of 5 years/7,500 hours.

BUS SERIES™		Total Coverage* (Included in acquisition price of transmission)
Model	Vocation	Years of Coverage (Standard Limited Warranty** + Partnership Coverage)
B 500	Intercity/Tour	2 + 3
B 500R	Intercity/Tour	2 + 3

For pricing and coverage information on B 300 and B 400 models, refer to the 2016 Transmission Coverage Pricing Guide, SA7749EN.

ASPEN A-75

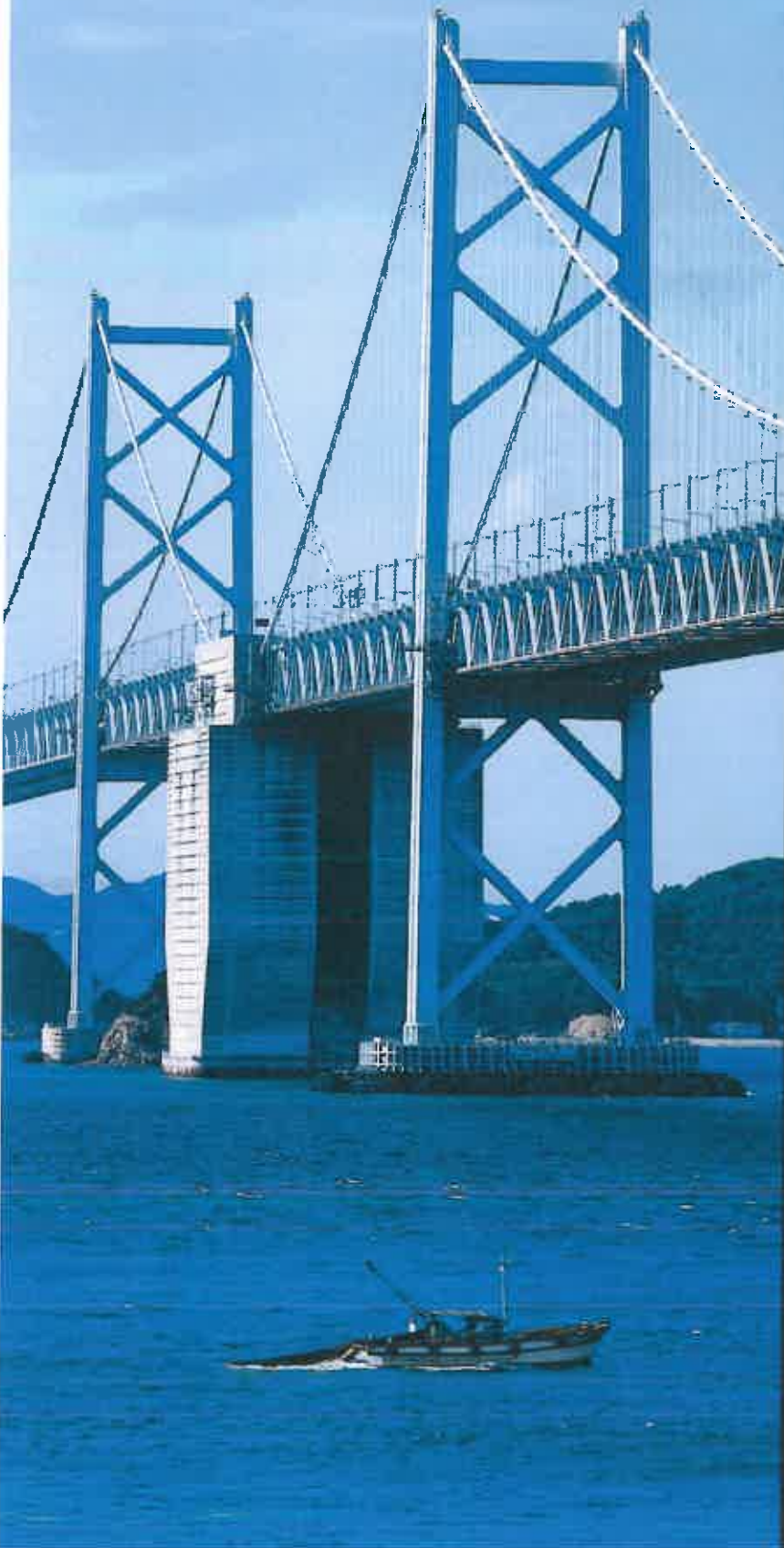

**EXTENDED
REACH TO
ACCESS
YOUR
WIDEST
BRIDGES**



ASPEN A-75

• 75' OF HORIZONTAL REACH

• EASY TO BOARD

• NO OUTRIGGERS



• 700 LB. PLATFORM CAPACITY

• 16' TELESCOPING 4TH BOOM

REMARKABLE VERSATILITY FROM THE WORLD'S LEADING MANUFACTURER OF BRIDGE ACCESS EQUIPMENT



• 85' VERTICAL REACH



• INTEGRATED CONTROL CONSOLE

PERFORMANCE CAPABILITIES

Set Up & Deployment – The Aspen A-75 can be set up, manned, and then fully deployed in less than 5 minutes. Workers in the platform can access their job area directly from the stowed position to ensure maximum safety and productivity.

Like all Aspen Aerials articulated equipment, the Aspen A-75 readily surpasses all stability requirements without requiring outrigger type stabilizers. Utilizing special hydraulically operated suspension lockouts and an innovative dual counterweight system, excessive point loading is essentially eliminated. This system occupies only 8' (2.4m) of the roadway while the unit is being operated, thus keeping lane closures to an absolute minimum.

Underdeck Access – The flexibility of the Aspen A-75 enables operators to get to virtually any location on even the largest bridges. The unique articulated boom design permits access around bridge members and light supports, over fences, across wide sidewalks, between cables and trusses and behind deep girders. Literally anywhere you need to be. The work envelope of the Aspen A-75 includes 75 feet (22.9m) of horizontal reach beneath the bridge deck and 85 feet (25.9m) of downward reach to inspect piers. And this is all accomplished while the operators are safely located in the platform with complete controls at their fingertips.

Through the Aspen A-75's dual turntable design, over 10,000 square feet (930 square meters) of underdeck area can be reached without ever having to advance the truck. However, when you need to relocate, the truck can be moved along the bridge while the booms are fully deployed, eliminating time consuming stowing and redeployment. In addition, the 180 degree rotation of Turntable #1 enables full boom deployment from either the driver or passenger side of the truck.

Deep Girder & Structure Access – When clear, safe access around, into and behind deep girder sections is necessary, the Aspen A-75 performs like no other. With the help of a innovative articulating/telescopic fourth boom, the Aspen A-75 places your technicians over 16 feet (4.9m) up into the girder system.

Overhead Access – The Aspen A-75 will not only get you to the areas under bridges that need checking, but those areas up to 53 feet (16.2m) above the deck as well.

Rely on Aspen Aerials for leading edge technology, superlative craftsmanship, lasting reliability and unparalleled support. Our years of experience and reputation for quality will ensure the continued safe operation of your equipment for years to come.



ASPEN A-75

STANDARD EQUIPMENT

High Capacity Platform – Spacious aluminum platform 40" x 60" (1016mm x 1524mm) with enough workspace for three (3) technicians and a 700 lb. (320kg) maximum capacity includes access gate for easy boarding

Three Operator Locations – Fully proportional controls are positioned at the platform, on the pedestal and attached to a remote extension for operation at the bridge edge. A hand held control digitizer personalizes control settings.

Communication System – Located at all work stations, this system provides continuous communication between the truck operator and inspectors to facilitate safe operation. "Hands-free" operation is incorporated at the platform.

Primary and Secondary Power Sources – To assure reliable performance.

Engine Shut Down System – With activation button at each control station.

Electrical System Diagnostics – Speeds troubleshooting with motion limitation indicator panel.

OPTIONAL EQUIPMENT AVAILABLE IN PLATFORM

- Heaters
- Floodlights
- Compressed Air Lines
- 110V/220V outlets
- Water lines
- Tool trays

The Aspen A-75 from Aspen Aerials is the largest, most innovative and versatile bridge access unit available.

All Aspen Aerials equipment is built in compliance with current ANSI A92.8 standards and backed by a complete warranty program. Contact the Aspen Aerials Product Support Group for technical support, on-site operator & maintenance training, parts and service.

From 17' to 75', Aspen Aerials offers the widest range of products to satisfy your needs.

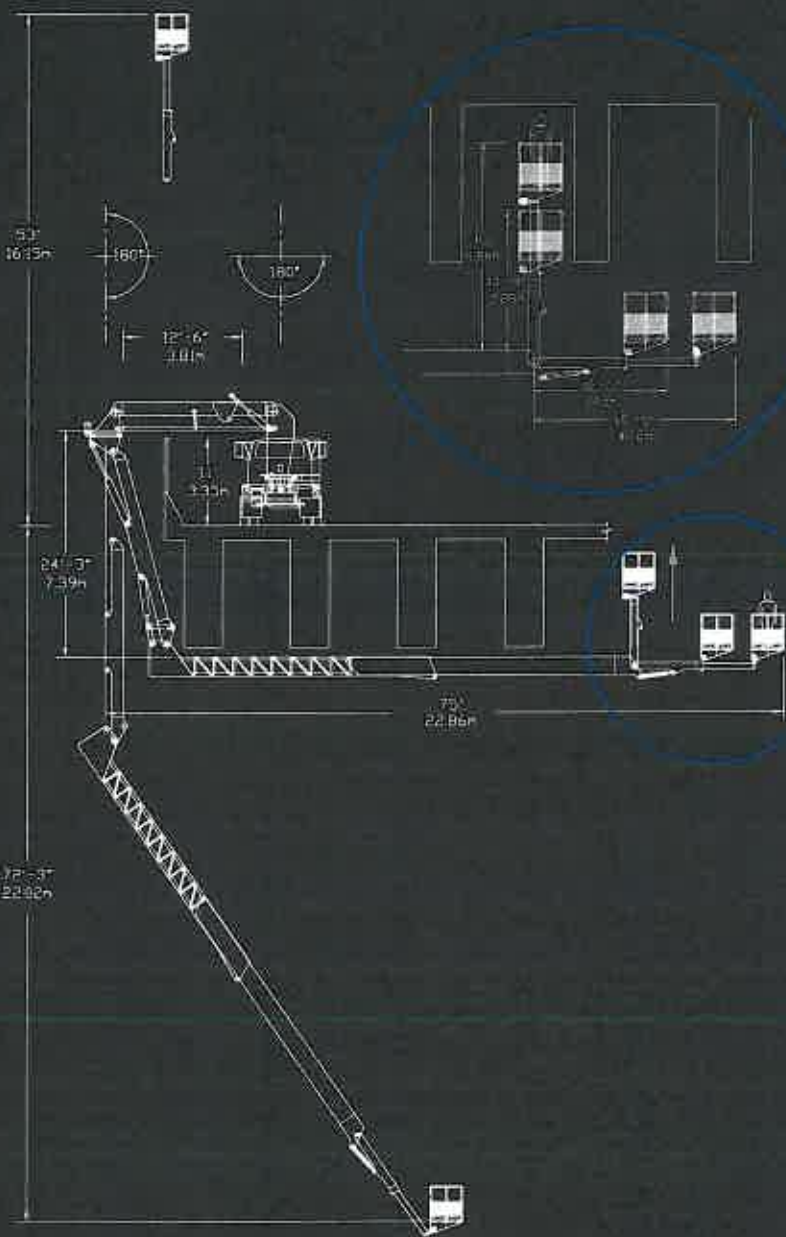

ASPEN AERIALS

BRIDGE INSPECTION AND MAINTENANCE SYSTEMS

4303 West 1st Street • Duluth, MN 55807 • USA

Phone (218) 624-1111 • Fax (218) 624-1714

US Toll Free (800) 888-2773

Visit our web site at www.aspen-aerials.com

Aspen Aerials, Inc. reserves the right to make changes to its designs and/or specifications without notice.

FREIGHTLINER

WORK SMART

122SD

VOCATIONAL SEVERE DUTY



**DETROIT
ENGINES™**

DD13

DD15 TC

DD16

VOCATIONAL PERFORMANCE



DETROIT
DEMAND PERFORMANCE