



Purchasing Division
 2019 Washington Street East
 Post Office Box 50130
 Charleston, WV 25305-0130

State of West Virginia
 Request for Quotation
 19 - Highways

Proc Folder: 271203

Doc Description: Addendum 2-Contract to Provide: Steel Double Drum Roller

Proc Type: Central Master Agreement

Date Issued	Solicitation Closes	Solicitation No	Version
2017-01-05	2017-01-17 13:30:00	CRFQ 0803 DOT1700000040	3

BID RECEIVING LOCATION

BID CLERK
 DEPARTMENT OF ADMINISTRATION
 PURCHASING DIVISION
 2019 WASHINGTON ST E
 CHARLESTON WV 25305
 US

VENDOR

Vendor Name, Address and Telephone Number:

STATE EQUIPMENT, INC.
 560 NEW GOFF MOUNTAIN ROAD
 CROSS LANES, WV 25313
 (304)776-4405

01/17/17 12:59:17
 WV Purchasing Division

FOR INFORMATION CONTACT THE BUYER

Charles D Barnette
 (304) 558-2566
 charles.d.barnette@wv.gov

Signature X

FEIN # 550658298

DATE 1/16/17

All offers subject to all terms and conditions contained in this solicitation

ADDITIONAL INFORMATION:

Addendum 2 - To publish the sign in sheet for the mandatory pre-bid meeting and provided responses to vendor questions.

INVOICE TO		SHIP TO	
DIVISION OF HIGHWAYS EQUIPMENT DIVISION RT 33 83 BRUSHY ROAD CROSSING, PO BOX 610 BUCKHANNON WV26201 US		DIVISION OF HIGHWAYS EQUIPMENT DIVISION 83 BRUSHY FORK RD CROSSING BUCKHANNON WV 26201 US	

Line	Comm Ln Desc	Qty	Unit Issue	Unit Price	Total Price
1	STEEL DOUBLE DRUM ROLLER	1.00000	EA	\$93,400.00 -	\$93,400.00

Comm Code	Manufacturer	Specification	Model #
24101723	CASE	STEEL DOUBLE DRUM ROLLER	DV210D

Extended Description :

CLASS 592 STEEL DOUBLE DRUM ROLLER

SCHEDULE OF EVENTS

Line	Event	Event Date
1	Mandatory Pre-Bid Meeting at 10:30 AM	2016-12-14
2	Technical Question Deadline by 4:00 PM	2016-12-23

DOT1700000040	Document Phase Final	Document Description Addendum 2-Contract to Provide: Steel Double Drum Roller	Page 3 of 3
----------------------	--------------------------------	--	------------------------------

ADDITIONAL TERMS AND CONDITIONS

See attached document(s) for additional Terms and Conditions

ADDENDUM ACKNOWLEDGEMENT FORM
SOLICITATION NO.: DOT1700000040

Instructions: Please acknowledge receipt of all addenda issued with this solicitation by completing this addendum acknowledgment form. Check the box next to each addendum received and sign below. Failure to acknowledge addenda may result in bid disqualification.

Acknowledgment: I hereby acknowledge receipt of the following addenda and have made the necessary revisions to my proposal, plans and/or specification, etc.

Addendum Numbers Received:

(Check the box next to each addendum received)

- | | |
|--|--|
| <input checked="" type="checkbox"/> Addendum No. 1 | <input type="checkbox"/> Addendum No. 6 |
| <input checked="" type="checkbox"/> Addendum No. 2 | <input type="checkbox"/> Addendum No. 7 |
| <input type="checkbox"/> Addendum No. 3 | <input type="checkbox"/> Addendum No. 8 |
| <input type="checkbox"/> Addendum No. 4 | <input type="checkbox"/> Addendum No. 9 |
| <input type="checkbox"/> Addendum No. 5 | <input type="checkbox"/> Addendum No. 10 |

I understand that failure to confirm the receipt of addenda may be cause for rejection of this bid. I further understand that any verbal representation made or assumed to be made during any oral discussion held between Vendor's representatives and any state personnel is not binding. Only the information issued in writing and added to the specifications by an official addendum is binding.

STATE EQUIPMENT, INC.

Company



Authorized Signature

1/16/17

Date

NOTE: This addendum acknowledgement should be submitted with the bid to expedite document processing.

Revised 6/8/2012

DESIGNATED CONTACT: Vendor appoints the individual identified in this Section as the Contract Administrator and the initial point of contact for matters relating to this Contract.

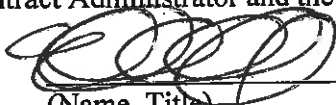
GENERAL MANAGER
(Name, Title)
EDDIE ROWAN, JR. GENERAL MANAGER
(Printed Name and Title)
560 NEW GOFF MOUNTAIN ROAD CROSS LANES, WV 25313
(Address)
(304) 776-4405 (304) 776-4409
(Phone Number) / (Fax Number)
EDDIE@STATEEQUIPMENT.COM
(email address)

CERTIFICATION AND SIGNATURE: By signing below, or submitting documentation through wvOASIS, I certify that I have reviewed this Solicitation in its entirety; that I understand the requirements, terms and conditions, and other information contained herein; that this bid, offer or proposal constitutes an offer to the State that cannot be unilaterally withdrawn; that the product or service proposed meets the mandatory requirements contained in the Solicitation for that product or service, unless otherwise stated herein; that the Vendor accepts the terms and conditions contained in the Solicitation, unless otherwise stated herein; that I am submitting this bid, offer or proposal for review and consideration; that I am authorized by the vendor to execute and submit this bid, offer, or proposal, or any documents related thereto on vendor's behalf; that I am authorized to bind the vendor in a contractual relationship; and that to the best of my knowledge, the vendor has properly registered with any State agency that may require registration.

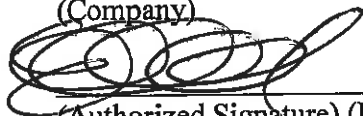
STATE EQUIPMENT, INC.
(Company)

EDDIE ROWAN, JR GENERAL MANAGER
(Authorized Signature) (Representative Name, Title)
EDDIE ROWAN, JR. GENERAL MANAGER
(Printed Name and Title of Authorized Representative)
1/16/17
(Date)
(304) 776-4405 (304) 776-4409
(Phone Number) (Fax Number)

REQUEST FOR QUOTATION – CRFQ DOT1700000040
CLASS 592 Steel Double Drum Roller

26201.

7. MISCELLANEOUS:

- 7.1 No Substitutions:** Vendor shall supply only Contract Items submitted in Response to the Solicitation unless a contract modification is approved in accordance with the provisions contained in this Contract.
- 7.2 Reports:** Vendor shall provide quarterly reports and annual summaries to the Agency showing the Agency's items purchased, quantities of items purchased, and total dollar value of the items purchased. Vendor shall also provide reports, upon request, showing the items purchased during the term of this Contract, the quantity purchased for each of those items, and the total value of purchases for each of those items. Failure to supply such reports may be grounds for cancellation of this Contract.
- 7.3 Contract Manager:** During its performance of this Contract, Vendor must designate and maintain a primary contract manager responsible for overseeing Vendor's responsibilities under this Contract. The Contract manager must be available during normal business hours to address any customer service or other issues related to this Contract. Vendor should list its Contract manager and his or her contact information below.

Contract Manager: EDDIE ROWAN, JR
Telephone Number: (304)776-4405
Fax Number: (304)776-4409
Email Address: EDDIE@STATEEQUIPMENT.COM

- 7.4 Operating and Service Manuals and Parts Lists:** An operator's manual must be included with each unit upon delivery. A "line sheet" (if applicable) and the "Equipment Preventative Maintenance Questionnaire", (Exhibit "B") must be with pilot unit upon delivery, Attn: Marcia Lee. There must be 12 service/shop/maintenance manuals and 14 parts manuals; CD-ROM is preferred in lieu of parts manuals. Manuals shall be delivered upon completion of delivery of total units. Failure to do so will delay payment.
- 7.5 Training:** Manufacturers and/or dealers will be required to stage a thorough seminar on the subjects of Preventative Maintenance, Operator, and Mechanic Training. In order to keep operators and mechanics updated, the successful vendor

Exhibit A

Pricing Sheet

CRFQ DOT1700000040

Item Number	Estimated Quantity	Unit of Measure	Description	Unit Price	Total
1	10	Each	One complete unit: Steel Double Drum Roller	\$93,400.00	\$934,000.00
				Grand Total	\$934,000.00

Vendor shall list the year, make, and model of the unit being bid:

Year: 2017

Make: CASE

Model: DV210D

State of West Virginia

VENDOR PREFERENCE CERTIFICATE

Certification and application is hereby made for Preference in accordance with *West Virginia Code*, §5A-3-37. (Does not apply to construction contracts). *West Virginia Code*, §5A-3-37, provides an opportunity for qualifying vendors to request (at the time of bid) preference for their residency status. Such preference is an evaluation method only and will be applied only to the cost bid in accordance with the *West Virginia Code*. This certificate for application is to be used to request such preference. The Purchasing Division will make the determination of the Vendor Preference, if applicable.

1. Application is made for 2.5% vendor preference for the reason checked:

- Bidder is an individual resident vendor and has resided continuously in West Virginia for four (4) years immediately preceding the date of this certification; or,
- Bidder is a partnership, association or corporation resident vendor and has maintained its headquarters or principal place of business continuously in West Virginia for four (4) years immediately preceding the date of this certification;
- Bidder is a resident vendor partnership, association, or corporation with at least eighty percent of ownership interest of bidder held by another entity that meets the applicable four year residency requirement; or,
- Bidder is a nonresident vendor which has an affiliate or subsidiary which employs a minimum of one hundred state residents and which has maintained its headquarters or principal place of business within West Virginia continuously for the four (4) years immediately preceding the date of this certification; or,

2. Application is made for 2.5% vendor preference for the reason checked:

- Bidder is a resident vendor who certifies that, during the life of the contract, on average at least 75% of the employees working on the project being bid are residents of West Virginia who have resided in the state continuously for the two years immediately preceding submission of this bid; or,

3. Application is made for 2.5% vendor preference for the reason checked:

- Bidder is a nonresident vendor that employs a minimum of one hundred state residents, or a nonresident vendor which has an affiliate or subsidiary which maintains its headquarters or principal place of business within West Virginia and employs a minimum of one hundred state residents, and for purposes of producing or distributing the commodities or completing the project which is the subject of the bidder's bid and continuously over the entire term of the project, on average at least seventy-five percent of the bidder's employees or the bidder's affiliate's or subsidiary's employees are residents of West Virginia who have resided in the state continuously for the two immediately preceding years and the vendor's bid; or,

4. Application is made for 5% vendor preference for the reason checked:

- Bidder meets either the requirement of both subdivisions (1) and (2) or subdivision (1) and (3) as stated above; or,

5. Application is made for 3.5% vendor preference who is a veteran for the reason checked:

- Bidder is an individual resident vendor who is a veteran of the United States armed forces, the reserves or the National Guard and has resided in West Virginia continuously for the four years immediately preceding the date on which the bid is submitted; or,

6. Application is made for 3.5% vendor preference who is a veteran for the reason checked:

- Bidder is a resident vendor who is a veteran of the United States armed forces, the reserves or the National Guard, if, for purposes of producing or distributing the commodities or completing the project which is the subject of the vendor's bid and continuously over the entire term of the project, on average at least seventy-five percent of the vendor's employees are residents of West Virginia who have resided in the state continuously for the two immediately preceding years.

7. Application is made for preference as a non-resident small, women- and minority-owned business, in accordance with *West Virginia Code* §5A-3-59 and *West Virginia Code of State Rules*.

- Bidder has been or expects to be approved prior to contract award by the Purchasing Division as a certified small, women- and minority-owned business.

Bidder understands if the Secretary of Revenue determines that a Bidder receiving preference has failed to continue to meet the requirements for such preference, the Secretary may order the Director of Purchasing to: (a) rescind the contract or purchase order; or (b) assess a penalty against such Bidder in an amount not to exceed 5% of the bid amount and that such penalty will be paid to the contracting agency or deducted from any unpaid balance on the contract or purchase order.

By submission of this certificate, Bidder agrees to disclose any reasonably requested information to the Purchasing Division and authorizes the Department of Revenue to disclose to the Director of Purchasing appropriate information verifying that Bidder has paid the required business taxes, provided that such information does not contain the amounts of taxes paid nor any other information deemed by the Tax Commissioner to be confidential.

Bidder hereby certifies that this certificate is true and accurate in all respects; and that if a contract is issued to Bidder and if anything contained within this certificate changes during the term of the contract, Bidder will notify the Purchasing Division in writing immediately.

Bidder: STATE EQUIPMENT, INC.

Signed: 

Date: 1/16/17

Title: GENERAL MANAGER

STATE OF WEST VIRGINIA
Purchasing Division

PURCHASING AFFIDAVIT

MANDATE: Under W. Va. Code §5A-3-10a, no contract or renewal of any contract may be awarded by the state or any of its political subdivisions to any vendor or prospective vendor when the vendor or prospective vendor or a related party to the vendor or prospective vendor is a debtor and: (1) the debt owed is an amount greater than one thousand dollars in the aggregate; or (2) the debtor is in employer default.

EXCEPTION: The prohibition listed above does not apply where a vendor has contested any tax administered pursuant to chapter eleven of the W. Va. Code, workers' compensation premium, permit fee or environmental fee or assessment and the matter has not become final or where the vendor has entered into a payment plan or agreement and the vendor is not in default of any of the provisions of such plan or agreement.

DEFINITIONS:

"Debt" means any assessment, premium, penalty, fine, tax or other amount of money owed to the state or any of its political subdivisions because of a judgment, fine, permit violation, license assessment, defaulted workers' compensation premium, penalty or other assessment presently delinquent or due and required to be paid to the state or any of its political subdivisions, including any interest or additional penalties accrued thereon.

"Employer default" means having an outstanding balance or liability to the old fund or to the uninsured employers' fund or being in policy default, as defined in W. Va. Code § 23-2c-2, failure to maintain mandatory workers' compensation coverage, or failure to fully meet its obligations as a workers' compensation self-insured employer. An employer is not in employer default if it has entered into a repayment agreement with the Insurance Commissioner and remains in compliance with the obligations under the repayment agreement.

"Related party" means a party, whether an individual, corporation, partnership, association, limited liability company or any other form or business association or other entity whatsoever, related to any vendor by blood, marriage, ownership or contract through which the party has a relationship of ownership or other interest with the vendor so that the party will actually or by effect receive or control a portion of the benefit, profit or other consideration from performance of a vendor contract with the party receiving an amount that meets or exceeds five percent of the total contract amount.

AFFIRMATION: By signing this form, the vendor's authorized signer affirms and acknowledges under penalty of law for false swearing (W. Va. Code §61-5-3) that neither vendor nor any related party owe a debt as defined above and that neither vendor nor any related party are in employer default as defined above, unless the debt or employer default is permitted under the exception above.

WITNESS THE FOLLOWING SIGNATURE:

Vendor's Name: STATE EQUIPMENT, INC.

Authorized Signature:  Date: 1/16/17

State of WEST VIRGINIA

County of KANAWHA, to-wit:

Taken, subscribed, and sworn to before me this 16th day of January, 2017.

My Commission expires March 27, 2021.

AFFIX SEAL HERE

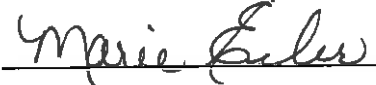
NOTARY PUBLIC 

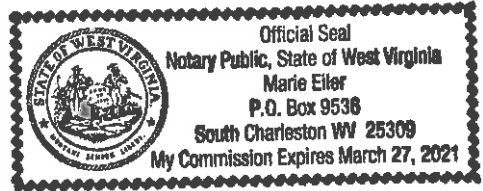



ENGINE

Make	Deutz TCD 3.6 L4
Emissions Certification	Tier 4 Final Certified
Type	Diesel
Cylinders	4
Displacement	221 in ³ (L)
Horsepower @ 2200 RPM	100 hp (74.4 kW)
Max. torque @ 1600 RPM	302.4 lb-ft (410 Nm)

DRIVETRAIN

Drive	Hydrostatic
Maximum speed	6.5 mph (10.5 kph)
Service brake	SAHR
Parking brake	Multi-disc
Emergency brake	Multi-disc
Drum drive	Front and rear drums
Drive motors – dual	1 x each drum
Drive motor pump	Variable displacement axial piston
Gradeability	30%

ELECTRICAL

Voltage	24 Volts
Battery	12-volt @ 420 CCA
Halogen work lights	4 (55 watt/front and rear)
Turn signals & four-way flashers	Left/right

OPERATOR ENVIRONMENT

Operator work stations	1
Seat – multi-position/suspension	1
Seat position	Rotating and pivoting
Lever travel control	1
Seat-belt – retractable	3 in (76.2 mm)
Steering column	Adjustable up/down
Rearview mirrors	2 – front frame mounted

OPERATING WEIGHT

Operating weight	22,930 lb (10 400 kg)
w/ cab option – add	970 lb (440 kg)
Front drum load	11,490 lb (5 210 kg)
Front drum linear load	173.6 lb/in (31 kg/cm)
Rear drum load	11,440 lb (5 190 kg)
Rear drum linear load	173 lb/in (30.9 kg/cm)
Single side edge cutter	330 lb (150 kg)
Double side edge cutter	660 lb (300 kg)

SERVICE CAPACITIES

Fuel tank	58.1 gal (220 L)
Engine oil	9.5 qt (9 L)
SCR tank	5.8 gal (22 L)
Hydraulic system – reservoir	16 gal (60 L)
Vibration system – each drum	2 gal (7.5 L)

OTHER SPECIFICATIONS

Steering:	
Pump type	Gear
Steering cylinders	2
Steering angle – left and right	31°
Oscillation angle +/-	6°
Inside turning radius	215 in (5 470 mm)
Outside turning radius	293 in (7 450 mm)

Water system:	
Water tank	222 gal (840 L) front frame mount
Water tank	Polyethylene
Water feed	Pressurized
Pumps	2
Fill ports	2
Filtration stages	3

Vibratory system:	
System design	Closed center
Pump type	Gear
Fixed displacement hydraulic motors	2
Vibration	Eccentric
Drum vibration	Front only/Rear only Front and rear

Frequency:	
Low	2,520 vpm (42 Hz)
High	3,120 vpm (52 Hz)
Amplitude:	
Low	0.014 in (0.35 mm)
High	0.032 in (0.82 mm)
Centrifugal force:	
Low	17,535 lb (78 kN)
High	26,977 lb (120 kN)

STANDARD EQUIPMENT

OTHER

Fixed ROPS/FOPS Canopy
Articulated chassis
Deutz TCD 3.6 L4/Tier 4 Final engine
Hydrostatic drive for both drums
Vulcollon drum scrapers – fixed
Machined tapered drum edges
Spin-on fuel, engine oil and hydraulic filters
Master disconnect switch
4-point lift and tie down provision
Worklights w/ turn signals
Back-up alarm
Brake release
Drum offset – crab steer

OPERATOR ENVIRONMENT

Iso-mounted operator's platform
Multi-position shifting suspension seat
w/ foldable armrests
Adjustable steering column
Single lever speed and direction control w/
vibration on/off control
Speed selector
Smooth start and stop
Return to center – offset
Handrails
Tool box
3 in retractable seat-belt
Emergency stop button
Seat safety switch

INSTRUMENT PANEL

Intelligent integrated display screen
Ignition lockout
Hour meter
Throttle control
Manual or auto vibration control
Water tank level
Fuel tank level
Vibration frequency
Sprinkler intensity

INDICATOR LIGHTS

Battery
Coolant level
Engine temperature warning
Air filter
Hydraulic filter
Hydraulic oil level
Parking brake
Fuel filter
Sprinkler on/off

MONITOR DISPLAY PANEL

- Engine RPM
- Engine hours
- Fuel rate
- System voltage
- % engine load at current RPM
- Coolant temperature
- Oil pressure
- Fuel economy
- Current fuel consumption
- Active service codes

WATER SYSTEM

- Pressurized water system
- Dual fill port water tank
- 3-stage water filtration
- Water system on/off
- Water system drain
- Adjustable sprinkler volume control

VIBRATION SYSTEM

- Front, rear, and dual drum vibration control modes
- Auto vibration stop in neutral
- Dual-mode vibratory system

OPTIONAL EQUIPMENT

OTHER

- Cab with heat and ventilation
- Cab air conditioning
- Radio mounting with 2 speakers and antenna – no radio
- Rotating beacon
- Right side edge cutter (45 or 60 degrees)
- Right and left side edge cutters (45 or 60 degrees)
- Tiltable scrapers – front and rear
- Infrared thermometer
- Cab mounted LED work lights
- 360 degree night illumination kit
- Left hand control lever – in addition to the right hand lever
- ACE Force Intelligent Compaction
- CASE SiteWatch

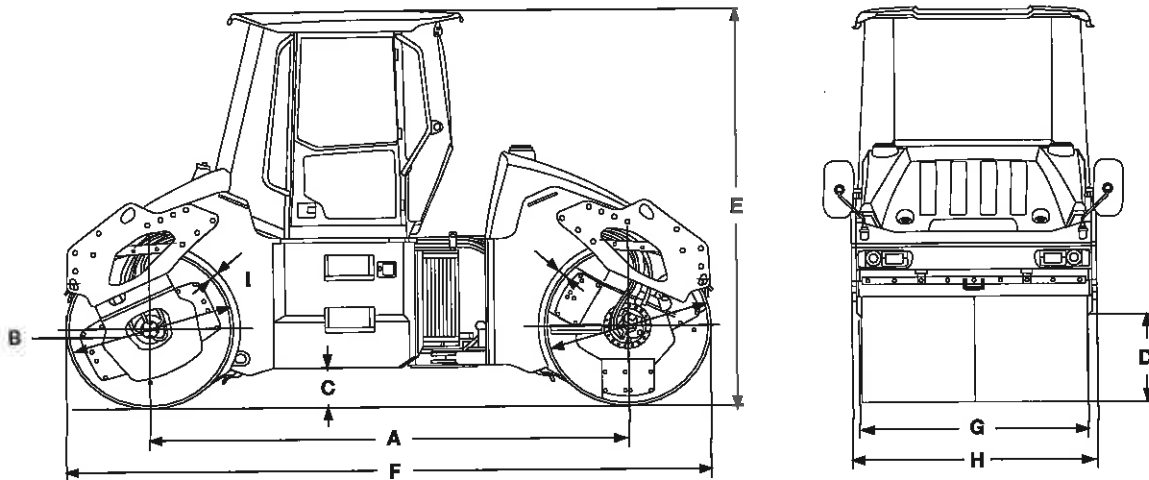

Line drawings are for illustrative purpose only and may not be exact representation of unit.

DIMENSIONS

A. Wheelbase	11 ft 5 in (3 500 mm)
B. Drum diameter	48 in (1 220 mm)
C. Curb clearance	11.8 in (300 mm)
D. Side clearance	30.7 in (780 mm)
E. Overall height	9 ft 10 in (3 000 mm)
F. Overall length	15 ft 5 in (4 720 mm)
G. Compaction width	66 in (1 680 mm)
H. Overall width	71 in (1 800 mm)
I. Drum thickness	0.9 in (22 mm)
Drum offset	6.7 in (170 mm)

CaseCE.com

©2016 CNH Industrial America LLC. All rights reserved. CASE is a trademark registered in the United States and many other countries, owned by or licensed to CNH Industrial N.V., its subsidiaries or affiliates. CNH Industrial Capital is a trademark in the United States and many other countries, owned by or licensed to CNH Industrial N.V., its subsidiaries or affiliates. Printed in U.S.A. Contains 10% post-consumer fiber.

IMPORTANT: CASE Construction Equipment Inc. reserves the right to change these specifications without notice and without incurring any obligation relating to such change. Availability of some models and equipment builds vary according to the country in which the equipment is used. The illustrations and text may include optional equipment and accessories and may not include all standard equipment. Your CASE dealer/distributor will be able to give you details of the products and their specifications available in your area.



CASE Construction Equipment is biodiesel-friendly. NOTE: All engines meet current EPA emissions regulations. All specifications are stated in accordance with SAE Standards or Recommended Practices, where applicable.



Always read the Operator's Manual before operating any equipment. Inspect equipment before using it, and be sure it is operating properly. Follow the product safety signs and use any safety features provided.

Form No. CCE201602DV210D
Replaces Form No. CCE201405DV210C

DV210D

**DV210D T4 FINAL DOUBLE DRUM COMPACTOR
US PRICE LIST**

Standard Equipment

ENGINE:

Deutz TCD 3.6 L4
Tier 4 Final certified
Horsepower
-100 Hp (74 kW)
Fuel tank capacity: 55 gallons (210 L)
SCR tank capacity: 5.8 gallons (22 L)

OPERATOR STRUCTURE:

Fixed ROPS/FOPS canopy
Iso-mounted operator's platform
In-steering wheel instrument panel
Adjustable steering column
Multi position suspension seat
-Foldable armrests
-Vinyl
-Handrails
Single lever control
-Ground speed and direction
-Vibration on/off control
-Water system on/off
Tool Box

DRUMS AND CHASSIS:

Articulated chassis
Hydrostatic drive (both drums)
Drum width: 66 in (1680 MM)
Drum diameter: 48" in (1220 MM)
-Machined tapered drum edges
Drum offset 7 in
(170 MM)
Drum drive motor
-Variable displacement axial
piston type drum drive pump
Hydraulic oil cooler
Dual frequency vibration (hi/lo)
Dual drum vibration modes
-Front drum only/both drums
-Auto vibration stop in neutral
-Tapered vibration start and stop
Adjustable Fixed Vulcollon scrapers
-2 x scrapers per drum
Recessed drum drive motors
Isolated rubber drum mounts
-Each drum x 6 per side

TRANSMISSION:

Variable displacement axial piston
drive pump

WEIGHT:

Operating Weight 22,930 lbs
(10,400 kg)
Front Drum Weight 11,490 lbs
(5,210 kg)
Rear Drum Weight 11,440 lbs
(5,190 kg)

VIBRATION:

Hydraulic circuit type - closed
Gear type pump
Fixed displacement
Two hydraulic motors
Vibration Eccentric
Frequency - Std
-Low 2520 vpm (42 Hz)
-High 3120 vpm (52 Hz)
Rated amplitude
-Low .014 in (0.35 mm)
-High .032 in (0.82 mm)
Centrifugal force
-Low 17,535 lbs (78 kN)
-High 26,977 lbs (120 kN)
Frequency - High
-Low 2760 vpm (46 Hz)
-High 4020 vpm (67 Hz)
Rated amplitude
-Low .009 in (0.22 mm)
-High .024 in (0.60 mm)
Centrifugal force
-Low 18,434 lbs (82 kN)
-High 23,605 lbs (105 kN)

ELECTRICAL:

Batteries - 1 x 12V @ 420 CCA
Master disconnect switch
Fuse protection cover
Turn signals and four-way flashers

DV210D T4 FINAL DOUBLE DRUM COMPACTOR
US PRICE LIST

Standard Equipment

WATER SYSTEM:

- Polyethylene water tank
- Water tank
 - 222 gallons (840 L) - front
- Pressurized sprinkler system
- Two water pumps
- Adjustable sprinkler volume control
- Three-stage water filtration
- Water tank drain
- Sprinkler system on/off switch
- Corrosion proof tank
- Dual fill port tank

STEERING:

- Pump type: gear
- Steering cylinders: 2
- Angle maximum (left and right)
 - 31 degrees
- Oscillation angle + or - 6 degrees
- Inner turning radius 17.9 ft (5470 mm)

OTHER:

- 3" Seat Belt
- SAHR service brake
- Multi disc parking/emergency brake
- Halogen worklights x 4
 - (55 watt/front and rear)
- Turn signal and four way flashers
- Backup alarm
- Lift and tie downs
- Horn
- Hour meter
- Emergency stop button
- Spin on fuel, engine oil and hydraulic filters
- Toolbox
- Indicator lights:
 - Battery
 - Engine Oil Pressure
 - Intake pre-heater
 - Engine temperature
 - Parking brake on/off
 - Sprinkler system on/off
 - Water tank level
 - Fuel level