



West Virginia Purchasing Division

2019 Washington Street, East
Charleston, WV 25305
Telephone: 304-558-2306
General Fax: 304-558-6026
Bid Fax: 304-558-3970

The following documentation is an electronically-submitted vendor response to an advertised solicitation from the *West Virginia Purchasing Bulletin* within the Vendor Self-Service portal at ***wvOASIS.gov***. As part of the State of West Virginia's procurement process, and to maintain the transparency of the bid-opening process, this documentation submitted online is publicly posted by the West Virginia Purchasing Division at ***WVPurchasing.gov*** with any other vendor responses to this solicitation submitted to the Purchasing Division in hard copy format.

Header

List View

General Information

Procurement Folder: 153046

Procurement Type: Central Purchase Order

Vendor ID: VS0000001756

Legal Name: CXT INC

Alias/DBA:

Total Bid: \$13,050.00

Response Date: 01/19/2016

Response Time: 14:37

SO Doc Code: CRFQ

SO Dept: 0803

SO Doc ID: DOT1600000056

Published Date: 1/7/16

Close Date: 1/20/16

Close Time: 13:30

Status: Closed

Solicitation Description: Addendum 1 PRECAST CONCRETE TRENCH DRAINS

Total of Header Attachments: 0

Total of All Attachments: 0



Purchasing Division
 2019 Washington Street East
 Post Office Box 50130
 Charleston, WV 25305-0130

**State of West Virginia
 Solicitation Response**

Proc Folder : 153046

Solicitation Description : Addendum 1 PRECAST CONCRETE TRENCH DRAINS

Proc Type : Central Purchase Order

Date issued	Solicitation Closes	Solicitation No	Version
	2016-01-20 13:30:00	SR 0803 ESR01191600000003066	1

VENDOR
VS0000001756 CXT INC

FOR INFORMATION CONTACT THE BUYER
 Mark A Atkins
 (304) 558-2307
 mark.a.atkins@wv.gov

Signature X FEIN # DATE

All offers subject to all terms and conditions contained in this solicitation

Line	Comm Ln Desc	Qty	Unit Issue	Unit Price	Ln Total Or Contract Amount
1	3.1.1 PRECAST CONCRETE TRENCH DRAIN WITH GRATE	24.00000	LF	\$225.000000	\$5,400.00

Comm Code	Manufacturer	Specification	Model #
30103619			

Extended Description :	3.1.1: 24 LINEAR FEET PRECAST CONCRETE TRENCH DRAIN WITH GRATE
-------------------------------	--

Line	Comm Ln Desc	Qty	Unit Issue	Unit Price	Ln Total Or Contract Amount
2	3.1.2 PRECAST CONCRETE TRENCH DRAIN WITH GRATE	34.00000	LF	\$225.000000	\$7,650.00

Comm Code	Manufacturer	Specification	Model #
30103619			

Extended Description :	3.1.2: 34 LINEAR FEET PRECAST CONCRETE TRENCH DRAIN WITH GRATE
-------------------------------	--



Purchasing Division
 2019 Washington Street East
 Post Office Box 50130
 Charleston, WV 25305-0130

State of West Virginia
 Request for Quotation
 19 - Highways

Proc Folder: 153046

Doc Description: Addendum 1 PRECAST CONCRETE TRENCH DRAINS

Proc Type: Central Purchase Order

Date Issued	Solicitation Closes	Solicitation No	Version
2016-01-07	2016-01-20 13:30:00	CRFQ 0803 DOT1600000056	2

BID RECEIVING LOCATION

BID CLERK
 DEPARTMENT OF ADMINISTRATION
 PURCHASING DIVISION
 2019 WASHINGTON ST E
 CHARLESTON WV 25305
 US

VENDOR

Vendor Name, Address and Telephone Number:
Carr Concrete a division of CXT, Inc.
P.O. Box 265
Waverly, WV 26184
304 - 464 - 4441

FOR INFORMATION CONTACT THE BUYER

Mark A Atkins
 (304) 558-2307
 mark.a.atkins@wv.gov

Signature X  FEIN # *91-1498605* DATE *1-19-16*

All offers subject to all terms and conditions contained in this solicitation

ADDITIONAL INFORMATION:

ADDENDUM 1 Vendor Questions and Responses per attached documents herein referenced as ATTACHMENT A and EXHIBIT 1.

The West Virginia Purchasing Division is soliciting bids on behalf of the Division of Highways to establish a contract for the one time purchase of Precast Concrete Trench Drains, per attached documents.

INVOICE TO		SHIP TO	
DIVISION OF HIGHWAYS DISTRICT SEVEN DRAWER 1228		DIVISION OF HIGHWAYS DISTRICT SEVEN STORAGE YARD 1205 US HWY 19 SOUTH	
WESTON	WV26452	WESTON	WV 26452
US		US	

Line	Comm Ln Desc	Qty	Unit Issue	Unit Price	Total Price
1	3.1.1 PRECAST CONCRETE TRENCH DRAIN WITH GRATE	24.00000	LF	225. ⁰⁰	\$5,400. ⁰⁰

Comm Code	Manufacturer	Specification	Model #
30103619			

Extended Description :

3.1.1: 24 LINEAR FEET PRECAST CONCRETE TRENCH DRAIN WITH GRATE

INVOICE TO		SHIP TO	
DIVISION OF HIGHWAYS DISTRICT SEVEN DRAWER 1228		DIVISION OF HIGHWAYS DISTRICT SEVEN STORAGE YARD 1205 US HWY 19 SOUTH	
WESTON	WV26452	WESTON	WV 26452
US		US	

Line	Comm Ln Desc	Qty	Unit Issue	Unit Price	Total Price
2	3.1.2 PRECAST CONCRETE TRENCH DRAIN WITH GRATE	34.00000	LF	225. ⁰⁰	\$7,650. ⁰⁰

Comm Code	Manufacturer	Specification	Model #
30103619			

Extended Description :

3.1.2: 34 LINEAR FEET PRECAST CONCRETE TRENCH DRAIN WITH GRATE

SCHEDULE OF EVENTS

Line	Event	Event Date
1	Technical Questions due by 4:00 pm	2016-01-06

DOT160000056	Document Phase Draft	Document Description Addendum 1 PRECAST CONCRETE T RENCH DRAINS	Page 3 of 3
---------------------	--------------------------------	--	------------------------------

ADDITIONAL TERMS AND CONDITIONS

See attached document(s) for additional Terms and Conditions

CERTIFICATION AND SIGNATURE PAGE

By signing below, or submitting documentation through wvOASIS, I certify that I have reviewed this Solicitation in its entirety; understand the requirements, terms and conditions, and other information contained herein; that I am submitting this bid, offer or proposal for review and consideration; that I am authorized by the vendor to execute and submit this bid, offer, or proposal, or any documents related thereto on vendor's behalf; that I am authorized to bind the vendor in a contractual relationship; and that to the best of my knowledge, the vendor has properly registered with any State agency that may require registration.

Carr Concrete a division of CXT, Inc.
(Company)

 Joe Keegan, Project Manager
(Authorized Signature) (Representative Name, Title)

304-464-4441 304-464-4013 1-19-16
(Phone Number) (Fax Number) (Date)

EXHIBIT 'A' Cost Sheet

Item Number	Quantity	Unit of Measure	Description	Unit Price	Extended Amount
3.1.1	24	Linear Feet	Precast Concrete Trench Drain with Grate. -One section totaling 24 feet	\$ 225. ⁰⁰	\$ 5,400. ⁰⁰
3.1.2	34	Linear Feet	Precast Concrete Trench Drain with Grate. -One section totaling 34 feet	\$ 225. ⁰⁰	\$ 7,650. ⁰⁰
Overall Total Cost					\$ 13,050. ⁰⁰

ADDENDUM ACKNOWLEDGEMENT FORM
SOLICITATION NO.: DOT1600000056

Instructions: Please acknowledge receipt of all addenda issued with this solicitation by completing this addendum acknowledgment form. Check the box next to each addendum received and sign below. Failure to acknowledge addenda may result in bid disqualification.

Acknowledgment: I hereby acknowledge receipt of the following addenda and have made the necessary revisions to my proposal, plans and/or specification, etc.

Addendum Numbers Received:

(Check the box next to each addendum received)

- | | |
|--|--|
| <input checked="" type="checkbox"/> Addendum No. 1 | <input type="checkbox"/> Addendum No. 6 |
| <input type="checkbox"/> Addendum No. 2 | <input type="checkbox"/> Addendum No. 7 |
| <input type="checkbox"/> Addendum No. 3 | <input type="checkbox"/> Addendum No. 8 |
| <input type="checkbox"/> Addendum No. 4 | <input type="checkbox"/> Addendum No. 9 |
| <input type="checkbox"/> Addendum No. 5 | <input type="checkbox"/> Addendum No. 10 |

I understand that failure to confirm the receipt of addenda may be cause for rejection of this bid. I further understand that any verbal representation made or assumed to be made during any oral discussion held between Vendor's representatives and any state personnel is not binding. Only the information issued in writing and added to the specifications by an official addendum is binding.

Carr Concrete a division of CRT, Inc

Company

[Signature]
Authorized Signature

1-19-16

Date

NOTE: This addendum acknowledgement should be submitted with the bid to expedite document processing.
Revised 6/8/2012

State of West Virginia

VENDOR PREFERENCE CERTIFICATE

Certification and application is hereby made for Preference in accordance with **West Virginia Code**, §5A-3-37. (Does not apply to construction contracts). **West Virginia Code**, §5A-3-37, provides an opportunity for qualifying vendors to request (at the time of bid) preference for their residency status. Such preference is an evaluation method only and will be applied only to the cost bid in accordance with the **West Virginia Code**. This certificate for application is to be used to request such preference. The Purchasing Division will make the determination of the Vendor Preference, if applicable.

1. Application is made for 2.5% vendor preference for the reason checked:

- Bidder is an individual resident vendor and has resided continuously in West Virginia for four (4) years immediately preceding the date of this certification; **or**,
- Bidder is a partnership, association or corporation resident vendor and has maintained its headquarters or principal place of business continuously in West Virginia for four (4) years immediately preceding the date of this certification; or 80% of the ownership interest of Bidder is held by another individual, partnership, association or corporation resident vendor who has maintained its headquarters or principal place of business continuously in West Virginia for four (4) years immediately preceding the date of this certification; **or**,
- Bidder is a nonresident vendor which has an affiliate or subsidiary which employs a minimum of one hundred state residents and which has maintained its headquarters or principal place of business within West Virginia continuously for the four (4) years immediately preceding the date of this certification; **or**,

2. Application is made for 2.5% vendor preference for the reason checked:

- Bidder is a resident vendor who certifies that, during the life of the contract, on average at least 75% of the employees working on the project being bid are residents of West Virginia who have resided in the state continuously for the two years immediately preceding submission of this bid; **or**,

3. Application is made for 2.5% vendor preference for the reason checked:

- Bidder is a nonresident vendor employing a minimum of one hundred state residents or is a nonresident vendor with an affiliate or subsidiary which maintains its headquarters or principal place of business within West Virginia employing a minimum of one hundred state residents who certifies that, during the life of the contract, on average at least 75% of the employees or Bidder's affiliate's or subsidiary's employees are residents of West Virginia who have resided in the state continuously for the two years immediately preceding submission of this bid; **or**,

4. Application is made for 5% vendor preference for the reason checked:

- Bidder meets either the requirement of both subdivisions (1) and (2) or subdivision (1) and (3) as stated above; **or**,

5. Application is made for 3.5% vendor preference who is a veteran for the reason checked:

- Bidder is an individual resident vendor who is a veteran of the United States armed forces, the reserves or the National Guard and has resided in West Virginia continuously for the four years immediately preceding the date on which the bid is submitted; **or**,

6. Application is made for 3.5% vendor preference who is a veteran for the reason checked:

- Bidder is a resident vendor who is a veteran of the United States armed forces, the reserves or the National Guard, if, for purposes of producing or distributing the commodities or completing the project which is the subject of the vendor's bid and continuously over the entire term of the project, on average at least seventy-five percent of the vendor's employees are residents of West Virginia who have resided in the state continuously for the two immediately preceding years.

7. Application is made for preference as a non-resident small, women- and minority-owned business, in accordance with West Virginia Code §5A-3-59 and West Virginia Code of State Rules.

- Bidder has been or expects to be approved prior to contract award by the Purchasing Division as a certified small, women- and minority-owned business.

Bidder understands if the Secretary of Revenue determines that a Bidder receiving preference has failed to continue to meet the requirements for such preference, the Secretary may order the Director of Purchasing to: (a) reject the bid; or (b) assess a penalty against such Bidder in an amount not to exceed 5% of the bid amount and that such penalty will be paid to the contracting agency or deducted from any unpaid balance on the contract or purchase order.

By submission of this certificate, Bidder agrees to disclose any reasonably requested information to the Purchasing Division and authorizes the Department of Revenue to disclose to the Director of Purchasing appropriate information verifying that Bidder has paid the required business taxes, provided that such information does not contain the amounts of taxes paid nor any other information deemed by the Tax Commissioner to be confidential.

Under penalty of law for false swearing (West Virginia Code, §61-5-3), Bidder hereby certifies that this certificate is true and accurate in all respects; and that if a contract is issued to Bidder and if anything contained within this certificate changes during the term of the contract, Bidder will notify the Purchasing Division in writing immediately.

Bidder: Carri Concrete a division of ExTime Signed: [Signature]

Date: 1-19-16 Title: Project Manager

PURCHASING AFFIDAVIT

MANDATE: Under W. Va. Code §5A-3-10a, no contract or renewal of any contract may be awarded by the state or any of its political subdivisions to any vendor or prospective vendor when the vendor or prospective vendor or a related party to the vendor or prospective vendor is a debtor and: (1) the debt owed is an amount greater than one thousand dollars in the aggregate; or (2) the debtor is in employer default.

EXCEPTION: The prohibition listed above does not apply where a vendor has contested any tax administered pursuant to chapter eleven of the W. Va. Code, workers' compensation premium, permit fee or environmental fee or assessment and the matter has not become final or where the vendor has entered into a payment plan or agreement and the vendor is not in default of any of the provisions of such plan or agreement.

DEFINITIONS:

"Debt" means any assessment, premium, penalty, fine, tax or other amount of money owed to the state or any of its political subdivisions because of a judgment, fine, permit violation, license assessment, defaulted workers' compensation premium, penalty or other assessment presently delinquent or due and required to be paid to the state or any of its political subdivisions, including any interest or additional penalties accrued thereon.

"Employer default" means having an outstanding balance or liability to the old fund or to the uninsured employers' fund or being in policy default, as defined in W. Va. Code § 23-2c-2, failure to maintain mandatory workers' compensation coverage, or failure to fully meet its obligations as a workers' compensation self-insured employer. An employer is not in employer default if it has entered into a repayment agreement with the Insurance Commissioner and remains in compliance with the obligations under the repayment agreement.

"Related party" means a party, whether an individual, corporation, partnership, association, limited liability company or any other form or business association or other entity whatsoever, related to any vendor by blood, marriage, ownership or contract through which the party has a relationship of ownership or other interest with the vendor so that the party will actually or by effect receive or control a portion of the benefit, profit or other consideration from performance of a vendor contract with the party receiving an amount that meets or exceeds five percent of the total contract amount.

AFFIRMATION: By signing this form, the vendor's authorized signer affirms and acknowledges under penalty of law for false swearing (W. Va. Code §61-5-3) that neither vendor nor any related party owe a debt as defined above and that neither vendor nor any related party are in employer default as defined above, unless the debt or employer default is permitted under the exception above.

WITNESS THE FOLLOWING SIGNATURE:

Vendor's Name: Carr Concrete a division of CXT, Inc.

Authorized Signature: [Signature] Date: 1-19-16

State of WV

County of Wood, to-wit:

Taken, subscribed, and sworn to before me this 19 day of January, 2016.

My Commission expires 2-8, 2020.

AFFIX SEAL HERE

NOTARY PUBLIC Windi Kapraun

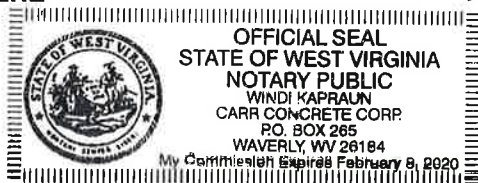

SOLICITATION NUMBER: CRFQ DOT1600000056

Addendum Number: 1

The purpose of this addendum is to modify the solicitation identified as (“Solicitation”) to reflect the change(s) identified and described below.

Applicable Addendum Category:

- Modify bid opening date and time
- Modify specifications of product or service being sought
- Attachment of vendor questions and responses
- Attachment of pre-bid sign-in sheet
- Correction of error
- Other

Description of Modification to Solicitation:

1. Vendor Questions and Responses attached.
2. Exhibit 1 Grate Pattern Type 1 attached.

No other changes made.

Additional Documentation: Documentation related to this Addendum (if any) has been included herewith as Attachment A and is specifically incorporated herein by reference.

Terms and Conditions:

1. All provisions of the Solicitation and other addenda not modified herein shall remain in full force and effect.
2. Vendor should acknowledge receipt of all addenda issued for this Solicitation by completing an Addendum Acknowledgment, a copy of which is included herewith. Failure to acknowledge addenda may result in bid disqualification. The addendum acknowledgement should be submitted with the bid to expedite document processing.

ATTACHMENT A

Addendum 1

CRFQ 0803 DOT160000056

Question:

I am contacting you concerning a quote that I am working on. I am looking at your Solicitation No. CRFQ 0803 DOT 1600000056 for Precast Concrete Trench Drains with Grates. I am having trouble locating the specified material for the grates. None of my suppliers are familiar with the Type 1 (bicycle proof) spec. There are many types of grating material available but most are identified by the number of bars and spacing. Can you give me any more information on this?

Answer:

The grate needs to be constructed using a Type 1 grate pattern. A section of the pattern to be used in construction of the trench grates is included in this addendum as Exhibit 1. The Type 1 section has been circled and labeled on the attachment.

DITCH GRADE	LD	L1 HORIZONTAL LENGTH (FT.)	L2 HORIZONTAL LENGTH (FT.)
FROM	TO		
0	3	10	15
3	5	8	20
5	7.5	8	40
7.5	UP	SPECIAL DESIGN	SPECIAL DESIGN

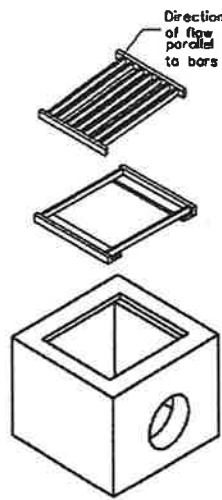
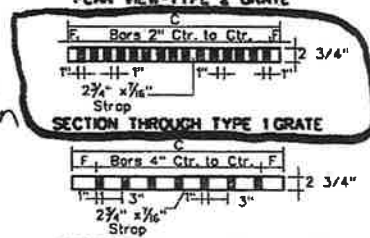
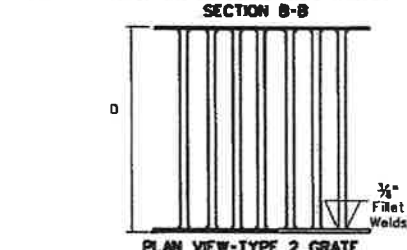
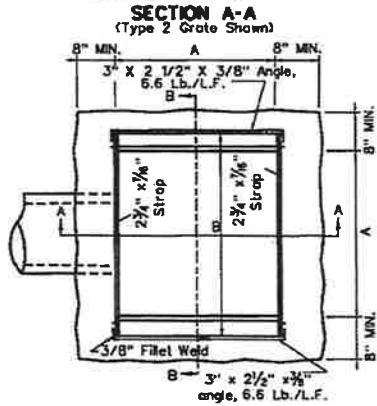
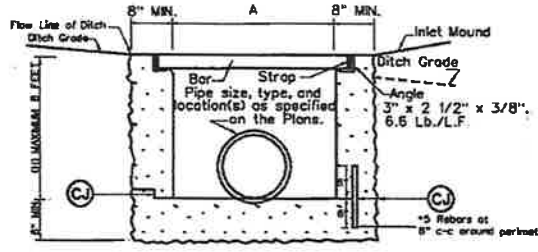
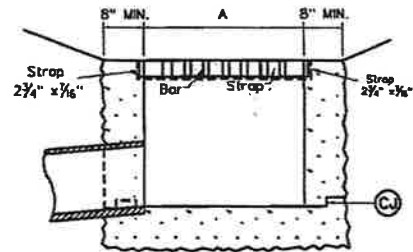
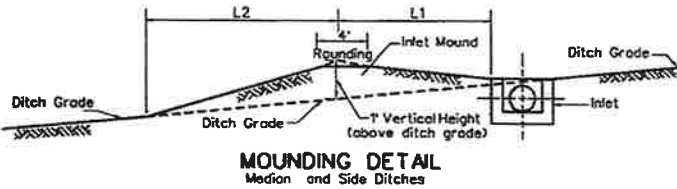

EXPLODED DETAIL

Nom Size	DIMENSIONS				TYPE 2 GRATE FRAME			TYPE 1 GRATE				
	A	B	C	D (NEMA)	F	Bars	WT.	F	Bars	WT.		
18"	2'-8"	3'-2"	2'-7 3/4"	3'-1 3/4"	2'-0"	3 3/8"	7	223	82	1 3/8"	15	453
24"	2'-8"	3'-2"	2'-7 3/4"	3'-1 3/4"	2'-3"	3 3/8"	7	223	82	1 3/8"	15	453
24"	2'-8"	3'-2"	2'-7 3/4"	3'-1 3/4"	2'-6"	3 3/8"	7	223	82	1 3/8"	15	453
27"	3'-0"	3'-6"	2'-11 3/4"	3'-5 3/4"	2'-9"	3 3/8"	8	279	89	1 3/8"	17	566
30"	3'-6"	4'-0"	3'-5 3/4"	3'-11 3/4"	3'-0"	3 3/8"	8	357	80	1 3/8"	21	797
33"	3'-9"	4'-3"	3'-8 3/4"	4'-2 3/4"	3'-3"	3 7/8"	10	410	85	1 7/8"	21	847
36"	4'-0"	4'-6"	3'-11 3/4"	4'-5 3/4"	3'-6"	3 3/8"	11	486	90	1 3/8"	23	981
42"	4'-6"	5'-0"	4'-5 3/4"	4'-11 3/4"	4'-0"	3 3/8"	12	587	101	1 3/8"	27	1277
48"	5'-0"	5'-6"	4'-11 3/4"	5'-5 3/4"	4'-8"	3 3/8"	14	748	112	1 3/8"	29	1507

Table Note: Grate and frame weights are for information only and will increase if larger straps and bars are used. The following substitutions in dimensions are acceptable for fabricating the grate and frame:
 Strap Thickness: 1/2" Strap Depth: 3" Bar Depth: 3"

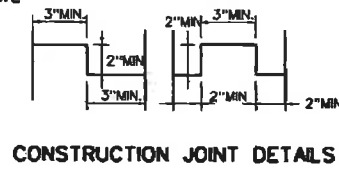

CONSTRUCTION JOINT DETAILS

NOTES

The final installed top surface of inlet and grate shall be flush with adjacent finished surfaces such as pavement, gutters, curbs, and sidewalks. Top of grate elevation, if shown on the plans, is for information only.

Construction may be cast-in place, precast in one or multiple sections, or any combination of cast-in-place and precast.

Type 2 Grate shall be used at all locations unless otherwise specified on the Plans. Type 1 Urban Grates shall be used only at specially designated locations as shown on the plans.

The Contractor, at his option, may omit use of the frame by forming a ledge in the concrete.

Special care shall be exercised in forming the 2" wide concrete ledge to provide a smooth, even surface for supporting the grates if the shallow frame is not used. No projections shall exist on the bearing surfaces of the ledge or the grates, and the grates shall seat on the ledge without rocking.

The Mounding Detail as shown is not required when an inlet is placed in a sag.

Optional construction joints labeled "CJ" may be roughened concrete, keyed or doweled as per the typical details shown herein or as approved by the Engineer. Non shrink grout meeting the requirements of subsection 715.5 of the specifications may be used to a depth of 1/2" for leveling between precast sections. Thicker depths will be allowed as per the manufacturer's recommendations.

This inlet is to be installed in roadside or median ditches only. It is not to be placed adjacent to pavement or in the gutter pan of combination curb and gutter.

The minimum distance from the top of any pipe opening to any construction joint above the opening shall be four (4) inches.

The number and location of pipe openings shall be as shown in the plans. The contractor at no additional cost, shall be responsible for any temporary bracing required to transport precast inlet sections due to multiple openings.

WEST VIRGINIA DEPARTMENT OF TRANSPORTATION
DIVISION OF HIGHWAYS
STANDARD DETAIL

PREPARED BY	
REVISION DATE	

TYPE G INLET