



Purchasing Division  
 2019 Washington Street East  
 Post Office Box 50130  
 Charleston, WV 25305-0130

State of West Virginia  
 Request for Quotation  
 13 - Equipment

Proc Folder: 117719

Doc Description: Excavator for the Veterans Cemetery

Proc Type: Central Purchase Order

Date Issued	Solicitation Closes	Solicitation No	Version
2015-06-26	2015-07-15 13:30:00	CRFQ 0613 VET1500000001	1

**LOCATION**  
 BID CLERK  
 DEPARTMENT OF ADMINISTRATION  
 PURCHASING DIVISION  
 2019 WASHINGTON ST E  
 CHARLESTON WV 25305  
 US

**VENDOR**  
 Vendor Name, Address and Telephone Number:  
 Bobcat of Advantage Valley a division of Jefferds Corporation  
 614 New Goff Mtn. Rd.  
 Cross Lanes WV 25313  
 304-776-9100

07/22/15 13:10:01  
 WV Purchasing Division

**FOR INFORMATION CONTACT THE BUYER**  
 Tara Lyle  
 (304) 558-2544  
 tara.l.lyle@wv.gov

Signature X  FEIN # 55-0336065 DATE 7/2/15  
 All offers subject to all terms and conditions contained in this solicitation

BILL TO		SHIP TO	
VETERANS AFFAIRS 130 ACADEMY DR		VETERANS AFFAIRS 130 ACADEMY DR	
DUNBAR	WV25064	DUNBAR	WV 25064
US		US	

Line	Comm Ln Desc	Qty	Unit Issue	Unit Price	Total Price
1	T4 compact Bobcat excavator or equal	1.00000	EA	52,472.00	52,472.00

Comm Code	Manufacturer	Specification	Model #
22100000	Bobcat	Excavator	E50

**Extended Description :**

The WV Purchasing Division for the agency, WV Department of Veterans Assistance, is soliciting bids for a one-time purchase of a compact excavator for the Donel C. Kinnard Memorial Cemetery located at 130 Academy Drive Dunbar, WV 25064, per the attached specifications.

VET1500000001	<b>Document Phase</b> Final	<b>Document Description</b> Excavator for the Veterans Cemetery	<b>Page 3</b> <b>of 3</b>
---------------	--------------------------------	--	------------------------------

**ADDITIONAL TERMS AND CONDITIONS**

See attached document(s) for additional Terms and Conditions



Purchasing Division  
 2019 Washington Street East  
 Post Office Box 50130  
 Charleston, WV 25305-0130

State of West Virginia  
 Request for Quotation  
 13 - Equipment

Proc Folder: 117719

Doc Description: Addendum 1 Excavator for the Veterans Cemetery

Proc Type: Central Purchase Order

Date Issued	Solicitation Closes	Solicitation No	Version
2015-07-09	2015-07-22 13:30:00	CRFQ 0613 VET1500000001	2

**BID RECEIVING LOCATION**

BID CLERK  
 DEPARTMENT OF ADMINISTRATION  
 PURCHASING DIVISION  
 2019 WASHINGTON ST E  
 CHARLESTON WV 25305  
 US

**VENDOR**

Vendor Name, Address and Telephone Number:

**FOR INFORMATION CONTACT THE BUYER**

Tara Lyle  
 (304) 558-2544  
 tara.l.yle@wv.gov

Signature X

FEIN #

DATE

All offers subject to all terms and conditions contained in this solicitation

INVOICE TO		SHIP TO	
VETERANS AFFAIRS 130 ACADEMY DR		VETERANS AFFAIRS 130 ACADEMY DR	
DUNBAR	WV25064	DUNBAR	WV 25064
US		US	

Line	Comm Ln Desc	Qty	Unit Issue	Unit Price	Total Price
1	T4 compact Bobcat excavator or equal	1.00000	EA		

Comm Code	Manufacturer	Specification	Model #
22100000			

**Extended Description :**

The WV Purchasing Division for the agency, WV Department of Veterans Assistance, is soliciting bids for a one-time purchase of a compact excavator for the Donel C. Kinnard Memorial Cemetery located at 130 Academy Drive Dunbar, WV 25064, per the attached specifications.

VET150000001	<b>Document Phase</b> Draft	<b>Document Description</b> Addendum 1 Excavator for the Veterans Cemetery	<b>Page 3</b> <b>of 3</b>
--------------	--------------------------------	---	------------------------------

**ADDITIONAL TERMS AND CONDITIONS**

See attached document(s) for additional Terms and Conditions

**SOLICITATION NUMBER: VET150000001**  
**Addendum Number: 1**

---

The purpose of this addendum is to modify the solicitation identified as (“Solicitation”) to reflect the change(s) identified and described below.

**Applicable Addendum Category:**

- Modify bid opening date and time
- Modify specifications of product or service being sought
- Attachment of vendor questions and responses
- Attachment of pre-bid sign-in sheet
- Correction of error
- Other

**Description of Modification to Solicitation:**

To extend the bid opening date to July 22, 2015 at 1:30 PM EST

To provide answers to vendor questions

**Additional Documentation:** Documentation related to this Addendum (if any) has been included herewith as Attachment A and is specifically incorporated herein by reference.

**Terms and Conditions:**

1. All provisions of the Solicitation and other addenda not modified herein shall remain in full force and effect.
2. Vendor should acknowledge receipt of all addenda issued for this Solicitation by completing an Addendum Acknowledgment, a copy of which is included herewith. Failure to acknowledge addenda may result in bid disqualification. The addendum acknowledgement should be submitted with the bid to expedite document processing.

# ATTACHMENT A



**CRFQ VET150000001**  
**Answers to Vendor Questions**

**Question 1.**

**3.1.1.1- Can we get HP lowered to 35HP minimum?**

**Answer: No, 40hp is the minimum**

**Question 2.**

**3.1.1.11-We do not have float with our blade, can we get changed**

**Answer: Can be dozer blade with or without float**

**Question 3.**

**3.1.1.14- Our boom swing control is a foot pedal, not fingertip control. Can we change?**

**Answer: Boomswing control by foot pedal or fingertip**

**Question 4.**

**We also weren't sure why 3.1.1.17 & 3.1.1.22 were both on there. I think they are just asking for a Hydraulic coupler if I'm not mistaken.**

**Answer: Yes, just asking for a hydraulic coupler**

**ADDENDUM ACKNOWLEDGEMENT FORM**  
**SOLICITATION NO.: VET15000001**

**Instructions:** Please acknowledge receipt of all addenda issued with this solicitation by completing this addendum acknowledgment form. Check the box next to each addendum received and sign below. Failure to acknowledge addenda may result in bid disqualification.

**Acknowledgment:** I hereby acknowledge receipt of the following addenda and have made the necessary revisions to my proposal, plans and/or specification, etc.

**Addendum Numbers Received:**

(Check the box next to each addendum received)

- |  |  |
|--|--|
| <input checked="" type="checkbox"/> Addendum No. 1 | <input type="checkbox"/> Addendum No. 6  |
| <input type="checkbox"/> Addendum No. 2            | <input type="checkbox"/> Addendum No. 7  |
| <input type="checkbox"/> Addendum No. 3            | <input type="checkbox"/> Addendum No. 8  |
| <input type="checkbox"/> Addendum No. 4            | <input type="checkbox"/> Addendum No. 9  |
| <input type="checkbox"/> Addendum No. 5            | <input type="checkbox"/> Addendum No. 10 |

I understand that failure to confirm the receipt of addenda may be cause for rejection of this bid. I further understand that any verbal representation made or assumed to be made during any oral discussion held between Vendor's representatives and any state personnel is not binding. Only the information issued in writing and added to the specifications by an official addendum is binding.

Bobcat of Adv. Valley / Jefferts Corp.  
Company

Joshua L. Mills  
Authorized Signature

7/13/15  
Date

**NOTE:** This addendum acknowledgment should be submitted with the bid to expedite document processing.  
Revised 6/8/2012

## INSTRUCTIONS TO VENDORS SUBMITTING BIDS

1. **REVIEW DOCUMENTS THOROUGHLY:** The attached documents contain a solicitation for bids. Please read these instructions and all documents attached in their entirety. These instructions provide critical information about requirements that if overlooked could lead to disqualification of a Vendor's bid. All bids must be submitted in accordance with the provisions contained in these instructions and the Solicitation. Failure to do so may result in disqualification of Vendor's bid.
2. **MANDATORY TERMS:** The Solicitation may contain mandatory provisions identified by the use of the words "must," "will," and "shall." Failure to comply with a mandatory term in the Solicitation will result in bid disqualification.
3. **PREBID MEETING:** The item identified below shall apply to this Solicitation.

A pre-bid meeting will not be held prior to bid opening.

A NON-MANDATORY PRE-BID meeting will be held at the following place and time:

A MANDATORY PRE-BID meeting will be held at the following place and time:

All Vendors submitting a bid must attend the mandatory pre-bid meeting. Failure to attend the mandatory pre-bid meeting shall result in disqualification of the Vendor's bid. No one person attending the pre-bid meeting may represent more than one Vendor.

An attendance sheet provided at the pre-bid meeting shall serve as the official document verifying attendance. The State will not accept any other form of proof or documentation to verify attendance. Any person attending the pre-bid meeting on behalf of a Vendor must list on the attendance sheet his or her name and the name of the Vendor he or she is representing. Additionally, the person attending the pre-bid meeting should include the Vendor's E-Mail address, phone number, and Fax number on the attendance sheet. It is the Vendor's responsibility to locate the attendance sheet and provide the required information. Failure to complete the attendance sheet as required may result in disqualification of Vendor's bid.

All Vendors should arrive prior to the starting time for the pre-bid. Vendors who arrive after the starting time but prior to the end of the pre-bid will be permitted to sign in, but are charged with knowing all matters discussed at the pre-bid.

Questions submitted at least five business days prior to a scheduled pre-bid will be discussed at the pre-bid meeting if possible. Any discussions or answers to questions at the pre-bid meeting are preliminary in nature and are non-binding. Official and binding answers to questions will be published in a written addendum to the Solicitation prior to bid opening.

- 4. VENDOR QUESTION DEADLINE:** Vendors may submit questions relating to this Solicitation to the Purchasing Division. Questions must be submitted in writing. All questions must be submitted on or before the date listed below and to the address listed below in order to be considered. A written response will be published in a Solicitation addendum if a response is possible and appropriate. Non-written discussions, conversations, or questions and answers regarding this Solicitation are preliminary in nature and are non-binding. Submitted e-mails should have solicitation number in the subject line.

Question Submission Deadline: July 7, 2015 by 4:00 pm

Submit Questions to: Tara Lyle  
2019 Washington Street, East  
Charleston, WV 25305  
Fax: (304) 558-4115 (Vendors should not use this fax number for bid submission)  
Email: Tara.L.Lyle@wv.gov

- 5. VERBAL COMMUNICATION:** Any verbal communication between the Vendor and any State personnel is not binding, including verbal communication at the mandatory pre-bid conference. Only information issued in writing and added to the Solicitation by an official written addendum by the Purchasing Division is binding.
- 6. BID SUBMISSION:** All bids must be submitted electronically through wvOASIS or signed and delivered by the Vendor to the Purchasing Division at the address listed below on or before the date and time of the bid opening. Any bid received by the Purchasing Division staff is considered to be in the possession of the Purchasing Division and will not be returned for any reason. The Purchasing Division will not accept bids, modification of bids, or addendum acknowledgment forms via e-mail. Acceptable delivery methods include electronic submission via wvOASIS, hand delivery, delivery by courier, or facsimile. The bid delivery address is:

Department of Administration, Purchasing Division  
2019 Washington Street East  
Charleston, WV 25305-0130

A bid that is not submitted electronically through wvOASIS should contain the information listed below on the face of the envelope or the bid may be rejected by the Purchasing Division.:

SEALED BID:  
BUYER:  
SOLICITATION NO.:  
BID OPENING DATE:  
BID OPENING TIME:  
FAX NUMBER:

In the event that Vendor is responding to a request for proposal, and chooses to respond in a manner other than by electronic submission through wvOASIS, the Vendor shall submit one original technical and one original cost proposal plus <sup>N/A</sup> convenience copies of each to the Purchasing Division at the address shown above. Additionally, if Vendor does not submit its bid through wvOASIS, the Vendor should identify the bid type as either a technical or cost proposal on the face of each bid envelope submitted in response to a request for proposal as follows:

BID TYPE: (This only applies to CRFP)

Technical

Cost

7. **BID OPENING:** Bids submitted in response to this Solicitation will be opened at the location identified below on the date and time listed below. Delivery of a bid after the bid opening date and time will result in bid disqualification. For purposes of this Solicitation, a bid is considered delivered when confirmation of delivery is provided by wvOASIS (in the case of electronic submission) or when the bid is time stamped by the official Purchasing Division time clock (in the case of hand delivery).

Bid Opening Date and Time: July 15, 2015 at 1:30 pm

Bid Opening Location: Department of Administration, Purchasing Division  
2019 Washington Street East  
Charleston, WV 25305-0130

8. **ADDENDUM ACKNOWLEDGEMENT:** Changes or revisions to this Solicitation will be made by an official written addendum issued by the Purchasing Division. Vendor should acknowledge receipt of all addenda issued with this Solicitation by completing an Addendum Acknowledgment Form, a copy of which is included herewith. Failure to acknowledge addenda may result in bid disqualification. The addendum acknowledgement should be submitted with the bid to expedite document processing.

9. **BID FORMATTING:** Vendor should type or electronically enter the information onto its bid to prevent errors in the evaluation. Failure to type or electronically enter the information may result in bid disqualification.
10. **ALTERNATES:** Any model, brand, or specification listed in this Solicitation establishes the acceptable level of quality only and is not intended to reflect a preference for, or in any way favor, a particular brand or vendor. Vendors may bid alternates to a listed model or brand provided that the alternate is at least equal to the model or brand and complies with the required specifications. The equality of any alternate being bid shall be determined by the State at its sole discretion. Any Vendor bidding an alternate model or brand should clearly identify the alternate items in its bid and should include manufacturer's specifications, industry literature, and/or any other relevant documentation demonstrating the equality of the alternate items. Failure to provide information for alternate items may be grounds for rejection of a Vendor's bid.
11. **EXCEPTIONS AND CLARIFICATIONS:** The Solicitation contains the specifications that shall form the basis of a contractual agreement. Vendor shall clearly mark any exceptions, clarifications, or other proposed modifications in its bid. Exceptions to, clarifications of, or modifications of a requirement or term and condition of the Solicitation may result in bid disqualification.
12. **COMMUNICATION LIMITATIONS:** In accordance with West Virginia Code of State Rules §148-1-6.6, communication with the State of West Virginia or any of its employees regarding this Solicitation during the solicitation, bid, evaluation or award periods, except through the Purchasing Division, is strictly prohibited without prior Purchasing Division approval. Purchasing Division approval for such communication is implied for all agency delegated and exempt purchases.
13. **REGISTRATION:** Prior to Contract award, the apparent successful Vendor must be properly registered with the West Virginia Purchasing Division and must have paid the \$125 fee, if applicable.
14. **UNIT PRICE:** Unit prices shall prevail in cases of a discrepancy in the Vendor's bid.
15. **PREFERENCE:** Vendor Preference may only be granted upon written request and only in accordance with the West Virginia Code § 5A-3-37 and the West Virginia Code of State Rules. A Vendor Preference Certificate form has been attached hereto to allow Vendor to apply for the preference. Vendor's failure to submit the Vendor Preference Certificate form with its bid will result in denial of Vendor Preference. Vendor Preference does not apply to construction projects.
16. **SMALL, WOMEN-OWNED, OR MINORITY-OWNED BUSINESSES:** For any solicitations publicly advertised for bid, in accordance with West Virginia Code §5A-3-37(a)(7) and W. Va. CSR § 148-22-9, any non-resident vendor certified as a small, women-owned, or minority-owned business under W. Va. CSR § 148-22-9 shall be provided the

same preference made available to any resident vendor. Any non-resident small, women-owned, or minority-owned business must identify itself as such in writing, must submit that writing to the Purchasing Division with its bid, and must be properly certified under W. Va. CSR § 148-22-9 prior to contract award to receive the preferences made available to resident vendors. Preference for a non-resident small, women-owned, or minority owned business shall be applied in accordance with W. Va. CSR § 148-22-9.

**17. WAIVER OF MINOR IRREGULARITIES:** The Director reserves the right to waive minor irregularities in bids or specifications in accordance with West Virginia Code of State Rules § 148-1-4.6.

**18. ELECTRONIC FILE ACCESS RESTRICTIONS:** Vendor must ensure that its submission in wvOASIS can be accessed by the Purchasing Division staff immediately upon bid opening. The Purchasing Division will consider any file that cannot be immediately opened and/or viewed at the time of the bid opening (such as, encrypted files, password protected files, or incompatible files) to be blank or incomplete as context requires, and are therefore unacceptable. A vendor will not be permitted to unencrypt files, remove password protections, or resubmit documents after bid opening if those documents are required with the bid.

## GENERAL TERMS AND CONDITIONS:

1. **CONTRACTUAL AGREEMENT:** Issuance of a Award Document signed by the Purchasing Division Director, or his designee, and approved as to form by the Attorney General's office constitutes acceptance of this Contract made by and between the State of West Virginia and the Vendor. Vendor's signature on its bid signifies Vendor's agreement to be bound by and accept the terms and conditions contained in this Contract.
  
2. **DEFINITIONS:** As used in this Solicitation/Contract, the following terms shall have the meanings attributed to them below. Additional definitions may be found in the specifications included with this Solicitation/Contract.
  - 2.1. **"Agency" or "Agencies"** means the agency, board, commission, or other entity of the State of West Virginia that is identified on the first page of the Solicitation or any other public entity seeking to procure goods or services under this Contract.
  - 2.2. **"Contract"** means the binding agreement that is entered into between the State and the Vendor to provide the goods or services requested in the Solicitation.
  - 2.3. **"Director"** means the Director of the West Virginia Department of Administration, Purchasing Division.
  - 2.4. **"Purchasing Division"** means the West Virginia Department of Administration, Purchasing Division.
  - 2.5. **"Award Document"** means the document signed by the Agency and the Purchasing Division, and approved as to form by the Attorney General, that identifies the Vendor as the contract holder.
  - 2.6. **"Solicitation"** means the official notice of an opportunity to supply the State with goods or services that is published by the Purchasing Division.
  - 2.7. **"State"** means the State of West Virginia and/or any of its agencies, commissions, boards, etc. as context requires.
  - 2.8. **"Vendor" or "Vendors"** means any entity submitting a bid in response to the Solicitation, the entity that has been selected as the lowest responsible bidder, or the entity that has been awarded the Contract as context requires.



3. **CONTRACT TERM; RENEWAL; EXTENSION:** The term of this Contract shall be determined in accordance with the category that has been identified as applicable to this Contract below:

**Term Contract**

**Initial Contract Term:** This Contract becomes effective on \_\_\_\_\_ and extends for a period of \_\_\_\_\_ year(s).

**Renewal Term:** This Contract may be renewed upon the mutual written consent of the Agency, and the Vendor, with approval of the Purchasing Division and the Attorney General's office (Attorney General approval is as to form only). Any request for renewal should be submitted to the Purchasing Division thirty (30) days prior to the expiration date of the initial contract term or appropriate renewal term. A Contract renewal shall be in accordance with the terms and conditions of the original contract. Renewal of this Contract is limited to \_\_\_\_\_ successive one (1) year periods or multiple renewal periods of less than one year, provided that the multiple renewal periods do not exceed \_\_\_\_\_ months in total. Automatic renewal of this Contract is prohibited. Notwithstanding the foregoing, Purchasing Division approval is not required on agency delegated or exempt purchases. Attorney General approval may be required for vendor terms and conditions.

**Delivery Order Limitations:** In the event that this contract permits delivery orders, a delivery order may only be issued during the time this Contract is in effect. Any delivery order issued within one year of the expiration of this Contract shall be effective for one year from the date the delivery order is issued. No delivery order may be extended beyond one year after this Contract has expired.

**Fixed Period Contract:** This Contract becomes effective upon Vendor's receipt of the notice to proceed and must be completed within \_\_\_\_\_ days.

**Fixed Period Contract with Renewals:** This Contract becomes effective upon Vendor's receipt of the notice to proceed and part of the Contract more fully described in the attached specifications must be completed within \_\_\_\_\_ days. Upon completion, the vendor agrees that maintenance, monitoring, or warranty services will be provided for one year thereafter with an additional \_\_\_\_\_ successive one year renewal periods or multiple renewal periods of less than one year provided that the multiple renewal periods do not exceed \_\_\_\_\_ months in total. Automatic renewal of this Contract is prohibited.

**One Time Purchase:** The term of this Contract shall run from the issuance of the Award Document until all of the goods contracted for have been delivered, but in no event will this Contract extend for more than one fiscal year.

**Other:** See attached.

4. **NOTICE TO PROCEED:** Vendor shall begin performance of this Contract immediately upon receiving notice to proceed unless otherwise instructed by the Agency. Unless otherwise specified, the fully executed Award Document will be considered notice to proceed.
5. **QUANTITIES:** The quantities required under this Contract shall be determined in accordance with the category that has been identified as applicable to this Contract below.
- Open End Contract:** Quantities listed in this Solicitation are approximations only, based on estimates supplied by the Agency. It is understood and agreed that the Contract shall cover the quantities actually ordered for delivery during the term of the Contract, whether more or less than the quantities shown.
- Service:** The scope of the service to be provided will be more clearly defined in the specifications included herewith.
- Combined Service and Goods:** The scope of the service and deliverable goods to be provided will be more clearly defined in the specifications included herewith.
- One Time Purchase:** This Contract is for the purchase of a set quantity of goods that are identified in the specifications included herewith. Once those items have been delivered, no additional goods may be procured under this Contract without an appropriate change order approved by the Vendor, Agency, Purchasing Division, and Attorney General's office.
6. **PRICING:** The pricing set forth herein is firm for the life of the Contract, unless specified elsewhere within this Solicitation/Contract by the State. A Vendor's inclusion of price adjustment provisions in its bid, without an express authorization from the State in the Solicitation to do so, may result in bid disqualification.
7. **EMERGENCY PURCHASES:** The Purchasing Division Director may authorize the Agency to purchase goods or services in the open market that Vendor would otherwise provide under this Contract if those goods or services are for immediate or expedited delivery in an emergency. Emergencies shall include, but are not limited to, delays in transportation or an unanticipated increase in the volume of work. An emergency purchase in the open market, approved by the Purchasing Division Director, shall not constitute a breach of this Contract and shall not entitle the Vendor to any form of compensation or damages. This provision does not excuse the State from fulfilling its obligations under a One Time Purchase contract.
8. **REQUIRED DOCUMENTS:** All of the items checked below must be provided to the Purchasing Division by the Vendor as specified below.

**BID BOND:** All Vendors shall furnish a bid bond in the amount of five percent (5%) of the total amount of the bid protecting the State of West Virginia. The bid bond must be submitted with the bid.

**PERFORMANCE BOND:** The apparent successful Vendor shall provide a performance bond in the amount of \_\_\_\_\_. The performance bond must be received by the Purchasing Division prior to Contract award. On construction contracts, the performance bond must be 100% of the Contract value.

**LABOR/MATERIAL PAYMENT BOND:** The apparent successful Vendor shall provide a labor/material payment bond in the amount of 100% of the Contract value. The labor/material payment bond must be delivered to the Purchasing Division prior to Contract award.

In lieu of the Bid Bond, Performance Bond, and Labor/Material Payment Bond, the Vendor may provide certified checks, cashier's checks, or irrevocable letters of credit. Any certified check, cashier's check, or irrevocable letter of credit provided in lieu of a bond must be of the same amount and delivered on the same schedule as the bond it replaces. A letter of credit submitted in lieu of a performance and labor/material payment bond will only be allowed for projects under \$100,000. Personal or business checks are not acceptable.

**MAINTENANCE BOND:** The apparent successful Vendor shall provide a two (2) year maintenance bond covering the roofing system. The maintenance bond must be issued and delivered to the Purchasing Division prior to Contract award.

**INSURANCE:** The apparent successful Vendor shall furnish proof of the following insurance prior to Contract award and shall list the state as a certificate holder:

**Commercial General Liability Insurance:** In the amount of \$250,000.00  
\_\_\_\_\_ or more.

**Builders Risk Insurance:** In an amount equal to 100% of the amount of the Contract.

The apparent successful Vendor shall also furnish proof of any additional insurance requirements contained in the specifications prior to Contract award regardless of whether or not that insurance requirement is listed above.

**LICENSE(S) / CERTIFICATIONS / PERMITS:** In addition to anything required under the Section entitled Licensing, of the General Terms and Conditions, the apparent successful Vendor shall furnish proof of the following licenses, certifications, and/or permits prior to Contract award, in a form acceptable to the Purchasing Division.

The apparent successful Vendor shall also furnish proof of any additional licenses or certifications contained in the specifications prior to Contract award regardless of whether or not that requirement is listed above.

**9. WORKERS' COMPENSATION INSURANCE:** The apparent successful Vendor shall comply with laws relating to workers compensation, shall maintain workers' compensation insurance when required, and shall furnish proof of workers' compensation insurance upon request.

**10. LITIGATION BOND:** The Director reserves the right to require any Vendor that files a protest of an award to submit a litigation bond in the amount equal to one percent of the lowest bid submitted or \$5,000, whichever is greater. The entire amount of the bond shall be forfeited if the hearing officer determines that the protest was filed for frivolous or improper purpose, including but not limited to, the purpose of harassing, causing unnecessary delay, or needless expense for the Agency. All litigation bonds shall be made payable to the Purchasing Division. In lieu of a bond, the protester may submit a cashier's check or certified check payable to the Purchasing Division. Cashier's or certified checks will be deposited with and held by the State Treasurer's office. If it is determined that the protest has not been filed for frivolous or improper purpose, the bond or deposit shall be returned in its entirety.

**11. LIQUIDATED DAMAGES:** Vendor shall pay liquidated damages in the amount of

for \_\_\_\_\_

This clause shall in no way be considered exclusive and shall not limit the State or Agency's right to pursue any other available remedy.

- 12. ACCEPTANCE/REJECTION:** The State may accept or reject any bid in whole, or in part. Vendor's signature on its bid signifies acceptance of the terms and conditions contained in the Solicitation and Vendor agrees to be bound by the terms of the Contract, as reflected in the Award Document, upon receipt.
- 13. FUNDING:** This Contract shall continue for the term stated herein, contingent upon funds being appropriated by the Legislature or otherwise being made available. In the event funds are not appropriated or otherwise made available, this Contract becomes void and of no effect beginning on July 1 of the fiscal year for which funding has not been appropriated or otherwise made available.
- 14. PAYMENT:** Payment in advance is prohibited under this Contract. Payment may only be made after the delivery and acceptance of goods or services. The Vendor shall submit invoices, in arrears.
- 15. TAXES:** The Vendor shall pay any applicable sales, use, personal property or any other taxes arising out of this Contract and the transactions contemplated thereby. The State of West Virginia is exempt from federal and state taxes and will not pay or reimburse such taxes.
- 16. CANCELLATION:** The Purchasing Division Director reserves the right to cancel this Contract immediately upon written notice to the vendor if the materials or workmanship supplied do not conform to the specifications contained in the Contract. The Purchasing Division Director may also cancel any purchase or Contract upon 30 days written notice to the Vendor in accordance with West Virginia Code of State Rules § 148-1-7.16.2.
- 17. TIME:** Time is of the essence with regard to all matters of time and performance in this Contract.
- 18. APPLICABLE LAW:** This Contract is governed by and interpreted under West Virginia law without giving effect to its choice of law principles. Any information provided in specification manuals, or any other source, verbal or written, which contradicts or violates the West Virginia Constitution, West Virginia Code or West Virginia Code of State Rules is void and of no effect.
- 19. COMPLIANCE:** Vendor shall comply with all applicable federal, state, and local laws, regulations and ordinances. By submitting a bid, Vendor acknowledges that it has reviewed, understands, and will comply with all applicable law.
- 20. PREVAILING WAGE:** On any contract for the construction of a public improvement whose cost at the time the contract is awarded will be paid with public money in an amount greater than \$500,000, Vendor and any subcontractors utilized by Vendor shall pay a rate or rates of wages which shall not be less than the fair minimum rate or rates of wages (prevailing wage), as established under West Virginia Code §§ 21-5A-1 et seq. Vendor shall

be responsible for ensuring compliance with prevailing wage requirements and determining when prevailing wage requirements are applicable.

21. **ARBITRATION:** Any references made to arbitration contained in this Contract, Vendor's bid, or in any American Institute of Architects documents pertaining to this Contract are hereby deleted, void, and of no effect.
22. **MODIFICATIONS:** This writing is the parties' final expression of intent. Notwithstanding anything contained in this Contract to the contrary, no modification of this Contract shall be binding without mutual written consent of the Agency, and the Vendor, with approval of the Purchasing Division and the Attorney General's office (Attorney General approval is as to form only). No Change shall be implemented by the Vendor until such time as the Vendor receives an approved written change order from the Purchasing Division.
23. **WAIVER:** The failure of either party to insist upon a strict performance of any of the terms or provision of this Contract, or to exercise any option, right, or remedy herein contained, shall not be construed as a waiver or a relinquishment for the future of such term, provision, option, right, or remedy, but the same shall continue in full force and effect. Any waiver must be expressly stated in writing and signed by the waiving party.
24. **SUBSEQUENT FORMS:** The terms and conditions contained in this Contract shall supersede any and all subsequent terms and conditions which may appear on any form documents submitted by Vendor to the Agency or Purchasing Division such as price lists, order forms, invoices, sales agreements, or maintenance agreements, and includes internet websites or other electronic documents. Acceptance or use of Vendor's forms does not constitute acceptance of the terms and conditions contained thereon.
25. **ASSIGNMENT:** Neither this Contract nor any monies due, or to become due hereunder, may be assigned by the Vendor without the express written consent of the Agency, the Purchasing Division, the Attorney General's office (as to form only), and any other government agency or office that may be required to approve such assignments. Notwithstanding the foregoing, Purchasing Division approval may or may not be required on certain agency delegated or exempt purchases.
26. **WARRANTY:** The Vendor expressly warrants that the goods and/or services covered by this Contract will: (a) conform to the specifications, drawings, samples, or other description furnished or specified by the Agency; (b) be merchantable and fit for the purpose intended; and (c) be free from defect in material and workmanship.
27. **STATE EMPLOYEES:** State employees are not permitted to utilize this Contract for personal use and the Vendor is prohibited from permitting or facilitating the same.
28. **BANKRUPTCY:** In the event the Vendor files for bankruptcy protection, the State of West Virginia may deem this Contract null and void, and terminate this Contract without notice.

**29. CONFIDENTIALITY:** The Vendor agrees that it will not disclose to anyone, directly or indirectly, any such personally identifiable information or other confidential information gained from the Agency, unless the individual who is the subject of the information consents to the disclosure in writing or the disclosure is made pursuant to the Agency's policies, procedures, and rules. Vendor further agrees to comply with the Confidentiality Policies and Information Security Accountability Requirements, set forth in <http://www.state.wv.us/admin/purchase/privacy/default.html>.

**30. DISCLOSURE:** Vendor's response to the Solicitation and the resulting Contract are considered public documents and will be disclosed to the public in accordance with the laws, rules, and policies governing the West Virginia Purchasing Division. Those laws include, but are not limited to, the Freedom of Information Act found in West Virginia Code §§ 29B-1-1 et seq. and the competitive bidding laws found West Virginia Code §§ 5A-3-1 et seq., 5-22-1 et seq., and 5G-1-1 et seq.

If a Vendor considers any part of its bid to be exempt from public disclosure, Vendor must so indicate by specifically identifying the exempt information, identifying the exemption that applies, providing a detailed justification for the exemption, segregating the exempt information from the general bid information, and submitting the exempt information as part of its bid but in a segregated and clearly identifiable format. Failure to comply with the foregoing requirements will result in public disclosure of the Vendor's bid without further notice. A Vendor's act of marking all or nearly all of its bid as exempt is not sufficient to avoid disclosure and **WILL NOT BE HONORED**. Vendor's act of marking a bid or any part thereof as "confidential" or "proprietary" is not sufficient to avoid disclosure and **WILL NOT BE HONORED**. A legend or other statement indicating that all or substantially all of the bid is exempt from disclosure is not sufficient to avoid disclosure and **WILL NOT BE HONORED**. Additionally, pricing or cost information will not be considered exempt from disclosure and requests to withhold publication of pricing or cost information **WILL NOT BE HONORED**.

Vendor will be required to defend any claimed exemption for nondisclosure in the event of an administrative or judicial challenge to the State's nondisclosure. Vendor must indemnify the State for any costs incurred related to any exemptions claimed by Vendor. Any questions regarding the applicability of the various public records laws should be addressed to your own legal counsel prior to bid submission.

**31. LICENSING:** In accordance with West Virginia Code of State Rules §148-1-6.1.7, Vendor must be licensed and in good standing in accordance with any and all state and local laws and requirements by any state or local agency of West Virginia, including, but not limited to, the West Virginia Secretary of State's Office, the West Virginia Tax Department, West Virginia Insurance Commission, or any other state agency or political subdivision. Upon request, the Vendor must provide all necessary releases to obtain information to enable the Purchasing Division Director or the Agency to verify that the Vendor is licensed and in good standing with the above entities.

**32. ANTITRUST:** In submitting a bid to, signing a contract with, or accepting a Award Document from any agency of the State of West Virginia, the Vendor agrees to convey, sell, assign, or transfer to the State of West Virginia all rights, title, and interest in and to all causes of action it may now or hereafter acquire under the antitrust laws of the United States and the State of West Virginia for price fixing and/or unreasonable restraints of trade relating to the particular commodities or services purchased or acquired by the State of West Virginia. Such assignment shall be made and become effective at the time the purchasing agency tenders the initial payment to Vendor.

**33. VENDOR CERTIFICATIONS:** By signing its bid or entering into this Contract, Vendor certifies (1) that its bid or offer was made without prior understanding, agreement, or connection with any corporation, firm, limited liability company, partnership, person or entity submitting a bid or offer for the same material, supplies, equipment or services; (2) that its bid or offer is in all respects fair and without collusion or fraud; (3) that this Contract is accepted or entered into without any prior understanding, agreement, or connection to any other entity that could be considered a violation of law; and (4) that it has reviewed this Solicitation in its entirety; understands the requirements, terms and conditions, and other information contained herein. Vendor's signature on its bid or offer also affirms that neither it nor its representatives have any interest, nor shall acquire any interest, direct or indirect, which would compromise the performance of its services hereunder. Any such interests shall be promptly presented in detail to the Agency. The individual signing this bid or offer on behalf of Vendor certifies that he or she is authorized by the Vendor to execute this bid or offer or any documents related thereto on Vendor's behalf; that he or she is authorized to bind the Vendor in a contractual relationship; and that, to the best of his or her knowledge, the Vendor has properly registered with any State agency that may require registration.

**34. PURCHASING CARD ACCEPTANCE:** The State of West Virginia currently utilizes a Purchasing Card program, administered under contract by a banking institution, to process payment for goods and services. The Vendor must accept the State of West Virginia's Purchasing Card for payment of all orders under this Contract unless the box below is checked.

Vendor is not required to accept the State of West Virginia's Purchasing Card as payment for all goods and services.

**35. VENDOR RELATIONSHIP:** The relationship of the Vendor to the State shall be that of an independent contractor and no principal-agent relationship or employer-employee relationship is contemplated or created by this Contract. The Vendor as an independent contractor is solely liable for the acts and omissions of its employees and agents. Vendor shall be responsible for selecting, supervising, and compensating any and all individuals employed pursuant to the terms of this Solicitation and resulting contract. Neither the Vendor, nor any employees or subcontractors of the Vendor, shall be deemed to be employees of the State for any purpose whatsoever. Vendor shall be exclusively responsible for payment of employees and contractors for all wages and salaries, taxes, withholding payments, penalties, fees, fringe benefits, professional liability insurance premiums, contributions to insurance and pension, or other deferred compensation plans, including but



not limited to, Workers' Compensation and Social Security obligations, licensing fees, etc. and the filing of all necessary documents, forms, and returns pertinent to all of the foregoing. Vendor shall hold harmless the State, and shall provide the State and Agency with a defense against any and all claims including, but not limited to, the foregoing payments, withholdings, contributions, taxes, Social Security taxes, and employer income tax returns.

**36. INDEMNIFICATION:** The Vendor agrees to indemnify, defend, and hold harmless the State and the Agency, their officers, and employees from and against: (1) Any claims or losses for services rendered by any subcontractor, person, or firm performing or supplying services, materials, or supplies in connection with the performance of the Contract; (2) Any claims or losses resulting to any person or entity injured or damaged by the Vendor, its officers, employees, or subcontractors by the publication, translation, reproduction, delivery, performance, use, or disposition of any data used under the Contract in a manner not authorized by the Contract, or by Federal or State statutes or regulations; and (3) Any failure of the Vendor, its officers, employees, or subcontractors to observe State and Federal laws including, but not limited to, labor and wage and hour laws.

**37. PURCHASING AFFIDAVIT:** In accordance with West Virginia Code § 5A-3-10a, all Vendors are required to sign, notarize, and submit the Purchasing Affidavit stating that neither the Vendor nor a related party owe a debt to the State in excess of \$1,000. The affidavit must be submitted prior to award, but should be submitted with the Vendor's bid. A copy of the Purchasing Affidavit is included herewith.

**38. ADDITIONAL AGENCY AND LOCAL GOVERNMENT USE:** This Contract may be utilized by and extends to other agencies, spending units, and political subdivisions of the State of West Virginia; county, municipal, and other local government bodies; and school districts ("Other Government Entities"). This Contract shall be extended to the aforementioned Other Government Entities on the same prices, terms, and conditions as those offered and agreed to in this Contract. If the Vendor does not wish to extend the prices, terms, and conditions of its bid and subsequent contract to the Other Government Entities, the Vendor must clearly indicate such refusal in its bid. A refusal to extend this Contract to the Other Government Entities shall not impact or influence the award of this Contract in any manner.

**39. CONFLICT OF INTEREST:** Vendor, its officers or members or employees, shall not presently have or acquire an interest, direct or indirect, which would conflict with or compromise the performance of its obligations hereunder. Vendor shall periodically inquire of its officers, members and employees to ensure that a conflict of interest does not arise. Any conflict of interest discovered shall be promptly presented in detail to the Agency.

**40. REPORTS:** Vendor shall provide the Agency and/or the Purchasing Division with the following reports identified by a checked box below:

- Such reports as the Agency and/or the Purchasing Division may request. Requested reports may include, but are not limited to, quantities purchased, agencies utilizing the contract, total contract expenditures by agency, etc.

- Quarterly reports detailing the total quantity of purchases in units and dollars, along with a listing of purchases by agency. Quarterly reports should be delivered to the Purchasing Division via email at [purchasing.requisitions@wv.gov](mailto:purchasing.requisitions@wv.gov).

**41. BACKGROUND CHECK:** In accordance with W. Va. Code § 15-2D-3, the Director of the Division of Protective Services shall require any service provider whose employees are regularly employed on the grounds or in the buildings of the Capitol complex or who have access to sensitive or critical information to submit to a fingerprint-based state and federal background inquiry through the state repository. The service provider is responsible for any costs associated with the fingerprint-based state and federal background inquiry.

After the contract for such services has been approved, but before any such employees are permitted to be on the grounds or in the buildings of the Capitol complex or have access to sensitive or critical information, the service provider shall submit a list of all persons who will be physically present and working at the Capitol complex to the Director of the Division of Protective Services for purposes of verifying compliance with this provision.

The State reserves the right to prohibit a service provider's employees from accessing sensitive or critical information or to be present at the Capitol complex based upon results addressed from a criminal background check.

Service providers should contact the West Virginia Division of Protective Services by phone at (304) 558-9911 for more information.

**42. PREFERENCE FOR USE OF DOMESTIC STEEL PRODUCTS:** Except when authorized by the Director of the Purchasing Division pursuant to W. Va. Code § 5A-3-56, no contractor may use or supply steel products for a State Contract Project other than those steel products made in the United States. A contractor who uses steel products in violation of this section may be subject to civil penalties pursuant to W. Va. Code § 5A-3-56. As used in this section:

- a. "State Contract Project" means any erection or construction of, or any addition to, alteration of or other improvement to any building or structure, including, but not limited to, roads or highways, or the installation of any heating or cooling or ventilating plants or other equipment, or the supply of and materials for such projects, pursuant to a contract with the State of West Virginia for which bids were solicited on or after June 6, 2001.
- b. "Steel Products" means products rolled, formed, shaped, drawn, extruded, forged, cast, fabricated or otherwise similarly processed, or processed by a combination of two or more or such operations, from steel made by the open heath, basic oxygen, electric furnace, Bessemer or other steel making process. The Purchasing Division Director may, in writing, authorize the use of foreign steel products if:
- c. The cost for each contract item used does not exceed one tenth of one percent (.1%) of the total contract cost or two thousand five hundred dollars (\$2,500.00), whichever is greater.

For the purposes of this section, the cost is the value of the steel product as delivered to the project; or

- d. The Director of the Purchasing Division determines that specified steel materials are not produced in the United States in sufficient quantity or otherwise are not reasonably available to meet contract requirements.

**43. PREFERENCE FOR USE OF DOMESTIC ALUMINUM, GLASS, AND STEEL:** In Accordance with W. Va. Code § 5-19-1 et seq., and W. Va. CSR § 148-10-1 et seq., for every contract or subcontract, subject to the limitations contained herein, for the construction, reconstruction, alteration, repair, improvement or maintenance of public works or for the purchase of any item of machinery or equipment to be used at sites of public works, only domestic aluminum, glass or steel products shall be supplied unless the spending officer determines, in writing, after the receipt of offers or bids, (1) that the cost of domestic aluminum, glass or steel products is unreasonable or inconsistent with the public interest of the State of West Virginia, (2) that domestic aluminum, glass or steel products are not produced in sufficient quantities to meet the contract requirements, or (3) the available domestic aluminum, glass, or steel do not meet the contract specifications. This provision only applies to public works contracts awarded in an amount more than fifty thousand dollars (\$50,000) or public works contracts that require more than ten thousand pounds of steel products.

The cost of domestic aluminum, glass, or steel products may be unreasonable if the cost is more than twenty percent (20%) of the bid or offered price for foreign made aluminum, glass, or steel products. If the domestic aluminum, glass or steel products to be supplied or produced in a "substantial labor surplus area", as defined by the United States Department of Labor, the cost of domestic aluminum, glass, or steel products may be unreasonable if the cost is more than thirty percent (30%) of the bid or offered price for foreign made aluminum, glass, or steel products.

This preference shall be applied to an item of machinery or equipment, as indicated above, when the item is a single unit of equipment or machinery manufactured primarily of aluminum, glass or steel, is part of a public works contract and has the sole purpose or of being a permanent part of a single public works project. This provision does not apply to equipment or machinery purchased by a spending unit for use by that spending unit and not as part of a single public works project.

All bids and offers including domestic aluminum, glass or steel products that exceed bid or offer prices including foreign aluminum, glass or steel products after application of the preferences provided in this provision may be reduced to a price equal to or lower than the lowest bid or offer price for foreign aluminum, glass or steel products plus the applicable preference. If the reduced bid or offer prices are made in writing and supersede the prior bid or offer prices, all bids or offers, including the reduced bid or offer prices, will be reevaluated in accordance with this rule.

**CERTIFICATION AND SIGNATURE PAGE**

By signing below, or submitting documentation through wvOASIS, I certify that I have reviewed this Solicitation in its entirety; understand the requirements, terms and conditions, and other information contained herein; that I am submitting this bid, offer or proposal for review and consideration; that I am authorized by the vendor to execute and submit this bid, offer, or proposal, or any documents related thereto on vendor's behalf; that I am authorized to bind the vendor in a contractual relationship; and that to the best of my knowledge, the vendor has properly registered with any State agency that may require registration.

Bobcat of Advantage Valley a division of Jeffers Corporation  
(Company)

 Branch Manager  
(Authorized Signature) (Representative Name, Title)

304-776-9100 304-776-0285 07/02/2015  
(Phone Number) (Fax Number) (Date)

# State of West Virginia VENDOR PREFERENCE CERTIFICATE

Certification and application\* is hereby made for Preference in accordance with *West Virginia Code*, §5A-3-37. (Does not apply to construction contracts). *West Virginia Code*, §5A-3-37, provides an opportunity for qualifying vendors to request (at the time of bid) preference for their residency status. Such preference is an evaluation method only and will be applied only to the cost bid in accordance with the *West Virginia Code*. This certificate for application is to be used to request such preference. The Purchasing Division will make the determination of the Vendor Preference, if applicable.

1. **Application is made for 2.5% vendor preference for the reason checked:**  
 Bidder is an individual resident vendor and has resided continuously in West Virginia for four (4) years immediately preceding the date of this certification; or,  
 Bidder is a partnership, association or corporation resident vendor and has maintained its headquarters or principal place of business continuously in West Virginia for four (4) years immediately preceding the date of this certification; or 80% of the ownership interest of Bidder is held by another individual, partnership, association or corporation resident vendor who has maintained its headquarters or principal place of business continuously in West Virginia for four (4) years immediately preceding the date of this certification; or,  
 Bidder is a nonresident vendor which has an affiliate or subsidiary which employs a minimum of one hundred state residents and which has maintained its headquarters or principal place of business within West Virginia continuously for the four (4) years immediately preceding the date of this certification; or,
2. **Application is made for 2.5% vendor preference for the reason checked:**  
 Bidder is a resident vendor who certifies that, during the life of the contract, on average at least 75% of the employees working on the project being bid are residents of West Virginia who have resided in the state continuously for the two years immediately preceding submission of this bid; or,
3. **Application is made for 2.5% vendor preference for the reason checked:**  
 Bidder is a nonresident vendor employing a minimum of one hundred state residents or is a nonresident vendor with an affiliate or subsidiary which maintains its headquarters or principal place of business within West Virginia employing a minimum of one hundred state residents who certifies that, during the life of the contract, on average at least 75% of the employees or Bidder's affiliate's or subsidiary's employees are residents of West Virginia who have resided in the state continuously for the two years immediately preceding submission of this bid; or,
4. **Application is made for 5% vendor preference for the reason checked:**  
 Bidder meets either the requirement of both subdivisions (1) and (2) or subdivision (1) and (3) as stated above; or,
5. **Application is made for 3.5% vendor preference who is a veteran for the reason checked:**  
 Bidder is an individual resident vendor who is a veteran of the United States armed forces, the reserves or the National Guard and has resided in West Virginia continuously for the four years immediately preceding the date on which the bid is submitted; or,
6. **Application is made for 3.5% vendor preference who is a veteran for the reason checked:**  
 Bidder is a resident vendor who is a veteran of the United States armed forces, the reserves or the National Guard, if, for purposes of producing or distributing the commodities or completing the project which is the subject of the vendor's bid and continuously over the entire term of the project, on average at least seventy-five percent of the vendor's employees are residents of West Virginia who have resided in the state continuously for the two immediately preceding years.
7. **Application is made for preference as a non-resident small, women- and minority-owned business, in accordance with *West Virginia Code* §5A-3-59 and *West Virginia Code of State Rules*.**  
 Bidder has been or expects to be approved prior to contract award by the Purchasing Division as a certified small, women- and minority-owned business.

Bidder understands if the Secretary of Revenue determines that a Bidder receiving preference has failed to continue to meet the requirements for such preference, the Secretary may order the Director of Purchasing to: (a) reject the bid; or (b) assess a penalty against such Bidder in an amount not to exceed 5% of the bid amount and that such penalty will be paid to the contracting agency or deducted from any unpaid balance on the contract or purchase order.

By submission of this certificate, Bidder agrees to disclose any reasonably requested information to the Purchasing Division and authorizes the Department of Revenue to disclose to the Director of Purchasing appropriate information verifying that Bidder has paid the required business taxes, provided that such information does not contain the amounts of taxes paid nor any other information deemed by the Tax Commissioner to be confidential.

Under penalty of law for false swearing (*West Virginia Code*, §61-5-3), Bidder hereby certifies that this certificate is true and accurate in all respects; and that if a contract is issued to Bidder and if anything contained within this certificate changes during the term of the contract, Bidder will notify the Purchasing Division in writing immediately.

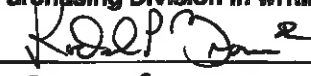
Bidder: JEFFERSON CORPORATION DBA ADVANTAGE <sup>Robert of</sup>  
Valley      Signed:   
 Date: 6-30-15      Title: Corp. Sec.

STATE OF WEST VIRGINIA  
Purchasing Division

**PURCHASING AFFIDAVIT**

**MANDATE:** Under W. Va. Code §5A-3-10a, no contract or renewal of any contract may be awarded by the state or any of its political subdivisions to any vendor or prospective vendor when the vendor or prospective vendor or a related party to the vendor or prospective vendor is a debtor and: (1) the debt owed is an amount greater than one thousand dollars in the aggregate; or (2) the debtor is in employer default.

**EXCEPTION:** The prohibition listed above does not apply where a vendor has contested any tax administered pursuant to chapter eleven of the W. Va. Code, workers' compensation premium, permit fee or environmental fee or assessment and the matter has not become final or where the vendor has entered into a payment plan or agreement and the vendor is not in default of any of the provisions of such plan or agreement.

**DEFINITIONS:**

**"Debt"** means any assessment, premium, penalty, fine, tax or other amount of money owed to the state or any of its political subdivisions because of a judgment, fine, permit violation, license assessment, defaulted workers' compensation premium, penalty or other assessment presently delinquent or due and required to be paid to the state or any of its political subdivisions, including any interest or additional penalties accrued thereon.

**"Employer default"** means having an outstanding balance or liability to the old fund or to the uninsured employers' fund or being in policy default, as defined in W. Va. Code § 23-2c-2, failure to maintain mandatory workers' compensation coverage, or failure to fully meet its obligations as a workers' compensation self-insured employer. An employer is not in employer default if it has entered into a repayment agreement with the Insurance Commissioner and remains in compliance with the obligations under the repayment agreement.

**"Related party"** means a party, whether an individual, corporation, partnership, association, limited liability company or any other form or business association or other entity whatsoever, related to any vendor by blood, marriage, ownership or contract through which the party has a relationship of ownership or other interest with the vendor so that the party will actually or by effect receive or control a portion of the benefit, profit or other consideration from performance of a vendor contract with the party receiving an amount that meets or exceeds five percent of the total contract amount.

**AFFIRMATION:** By signing this form, the vendor's authorized signer affirms and acknowledges under penalty of law for false swearing (W. Va. Code §61-5-3) that neither vendor nor any related party owe a debt as defined above and that neither vendor nor any related party are in employer default as defined above, unless the debt or employer default is permitted under the exception above.

**WITNESS THE FOLLOWING SIGNATURE:**

Vendor's Name: JEFFERDS CORPORATION DBA Bobcat of Advantage Valley

Authorized Signature: [Signature] Date: 6-30-15

State of West Virginia

County of Putnam, to-wit:

Taken, subscribed, and sworn to before me this 30 day of June, 2015

My Commission expires 6-30, 2018.

**AFFIX SEAL HERE**

NOTARY PUBLIC [Signature]

*Purchasing Affidavit (Revised 07/01/2012)*

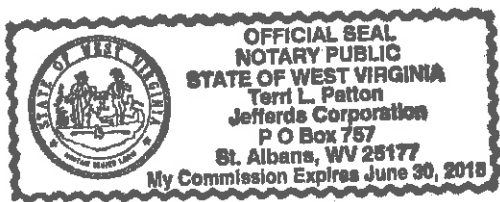

**REQUEST FOR QUOTATION**  
**CRFQ VET1500000001 – Compact Excavator**

---

**SPECIFICATIONS**

- 1. PURPOSE AND SCOPE:** The West Virginia Purchasing Division is soliciting bids on behalf of WV Department of Veterans Assistance to establish a contract for the one time purchase of an E50 T4 Bobcat compact excavator, or equal.
- 2. DEFINITIONS:** The terms listed below shall have the meanings assigned to them below. Additional definitions can be found in section 2 of the General Terms and Conditions.
  - 2.1 “Contract Item”** means E50 T4 Bobcat compact excavator, or equal as more fully described by these specifications.
  - 2.2 “Pricing Page”** means the pages, contained in wvOASIS or attached as Exhibit A, upon which Vendor should list its proposed price for the Contract Items.
  - 2.3 “Solicitation”** means the official notice of an opportunity to supply the State with goods or services that is published by the Purchasing Division.
- 3. GENERAL REQUIREMENTS:**
  - 3.1 Mandatory Contract Item Requirements:** Contract Item must meet or exceed the mandatory requirements listed below.
    - 3.1.1 Contract Item #1 - E50 T4 Bobcat compact excavator, or equal.**
      - 3.1.1.1** Minimum 49.8 HP Tier 4 auto idle;
      - 3.1.1.2** Auto shift
      - 3.1.1.3** Auxiliary hydraulics
      - 3.1.1.4** Selectable flow with boom mounted flush face quick couplers
      - 3.1.1.5** Cab forward standard display
      - 3.1.1.6** Canopy including cup holder, retractable seat belt, suspension seat with high back
      - 3.1.1.7** Rollover protective structure meeting requirements of ISO 12117-2:2008;
      - 3.1.1.8** Tip over protective structure meeting the requirements of ISO12117:2000;
      - 3.1.1.9** Control console locks;
      - 3.1.1.10** Control pattern selector valve (ISO/STD);
      - 3.1.1.11** Dozer blade with float

**REQUEST FOR QUOTATION**  
**CRFQ VET1500000001 – Compact Excavator**

---

- 3.1.1.12** Engine/hydraulic monitor with shutdown;
- 3.1.1.13** Fingertip auxiliary hydraulic control;
- 3.1.1.14** Fingertip boom swing control, horn, hydraulic joystick controls, rubber track, minimum two-speed with auto-shift, vandalism protection;
- 3.1.1.15** 1 year warranty;
- 3.1.1.16** Work lights
- 3.1.1.17** X-change or equal attachment mounting system;
- 3.1.1.18** Hydraulic angle blade;
- 3.1.1.19** Travel motion alarm kit;
- 3.1.1.20** Strobe light kit;
- 3.1.1.21** Minimum 36" sever duty bucket;
- 3.1.1.22** Hydraulic X-Change or equal.

**4. CONTRACT AWARD:**

**4.1 Contract Award:** The Contract is intended to provide Agencies with a purchase price for the Contract Items. The Contract shall be awarded to the Vendor that provides the Contract Items meeting the required specifications for the lowest overall total cost as shown on the Pricing Pages.

**4.2 Pricing Page:** Vendor should complete the Pricing Page by providing a lump sum total for the item. Vendor should complete the Pricing Page in full as failure to complete the Pricing Page in its entirety may result in Vendor's bid being disqualified.

Vendor should type or electronically enter the information into the Pricing Page to prevent errors in the evaluation.

**5. PAYMENT:**

**5.1 Payment:** Vendor shall accept payment in accordance with the payment procedures of the State of West Virginia.



REQUEST FOR QUOTATION  
CRFQ VET1500000001 – Compact Excavator

---

**6. DELIVERY AND RETURN:**

**6.1 Shipment and Delivery:** Vendor shall ship the Contract Items immediately after being awarded this Contract and receiving a purchase order or notice to proceed. Vendor shall deliver the Contract Items within 45 working days after receiving a purchase order or notice to proceed. Contract Items must be delivered to Agency at Donel C. Kinnard Memorial Cemetery located at 130 Academy Drive Dunbar, WV 25064.

**6.2 Late Delivery:** The Agency placing the order under this Contract must be notified in writing if the shipment of the Contract Items will be delayed for any reason. Any delay in delivery that could cause harm to an Agency will be grounds for cancellation of the Contract, and/or obtaining the Contract Items from a third party.

Any Agency seeking to obtain the Contract Items from a third party under this provision must first obtain approval of the Purchasing Division.

**6.3 Delivery Payment/Risk of Loss:** Vendor shall deliver the Contract Items F.O.B. destination to the Agency's location.

**6.4 Return of Unacceptable Items:** If the Agency deems the Contract Items to be unacceptable, the Contract Items shall be returned to Vendor at Vendor's expense and with no restocking charge. Vendor shall either make arrangements for the return within five (5) days of being notified that items are unacceptable, or permit the Agency to arrange for the return and reimburse Agency for delivery expenses. If the original packaging cannot be utilized for the return, Vendor will supply the Agency with appropriate return packaging upon request. All returns of unacceptable items shall be F.O.B. the Agency's location. The returned product shall either be replaced, or the Agency shall receive a full credit or refund for the purchase price, at the Agency's discretion.

**6.5 Return Due to Agency Error:** Items ordered in error by the Agency will be returned for credit within 30 days of receipt, F.O.B. Vendor's location. Vendor shall not charge a restocking fee if returned products are in a resalable condition. Items shall be deemed to be in a resalable condition if they are unused and in the original packaging. Any restocking fee for items not in a resalable condition shall be the lower of the Vendor's customary restocking fee or 5% of the total invoiced value of the returned items.

**REQUEST FOR QUOTATION  
CRFQ VET1500000001 – Compact Excavator**

---

**7 VENDOR DEFAULT:**

**7.1 The following shall be considered a vendor default under this Contract.**

- 7.1.1 Failure to provide Contract Items in accordance with the requirements contained herein.**
- 7.1.2 Failure to comply with other specifications and requirements contained herein.**
- 7.1.3 Failure to comply with any laws, rules, and ordinances applicable to the Contract Services provided under this Contract.**
- 7.1.4 Failure to remedy deficient performance upon request.**

**7.2 The following remedies shall be available to Agency upon default.**

- 7.2.1 Immediate cancellation of the Contract.**
- 7.2.2 Immediate cancellation of one or more release orders issued under this Contract.**
- 7.2.3 Any other remedies available in law or equity.**



## Product Quotation

Quotation Number: 19203D020613

Date: 2015-06-30 07:34:57

Ship to	Bobcat Dealer	Bill To
Donel C. Kinnard Memorial Cemetery Attn: Kevin 130 Academy Drive Dunbar, WV 25064 Phone: (304) 746-0026	Bobcat of Advantage Valley 614 GOFF MOUNTAIN ROAD CROSS LANES WV 25313 Phone: (304) 776-9100 Fax: (304) 776-0285  Contact: Joshua Mills Phone: 304-776-9100 Fax: 304-776-0285 E Mail: joshuamills@jefferds.com	Donel C. Kinnard Memorial Cemetery Attn: Kevin 130 Academy Drive Dunbar, WV 25064 Phone: (304) 746-0026

Description	Part No	Qty	Price Ea.	Total
<b>E50 T4 Bobcat Compact Excavator</b>	<b>M3219</b>	<b>1</b>	<b>\$44,133.00</b>	<b>\$44,133.00</b>
49.8 HP Tier 4	Control Pattern Selector Valve (ISO/STD)			
Auto Idle	Dozer Blade with Float			
Auto-Shift	Engine/Hydraulic Monitor with Shutdown			
Auxiliary Hydraulics, Selectable Flow with Boom Mounted	Fingertip Auxiliary Hydraulic Control			
Flush Face Quick Couplers	Fingertip Boom Swing Control			
Cab Forward Standard Display	Horn			
Canopy	Hydraulic Joystick Controls			
Includes: Cup Holder, Retractable Seat Belt, Suspension Seat with High Back	Rubber Track			
Roll Over Protective Structure (ROPS)- Meets Requirements of ISO 12117-2: 2008	Two-Speed Travel (with Auto-Shift)			
Tip Over Protective Structure (TOPS) - Meets Requirements of ISO 12117: 2000	Vandalism Protection			
Control Console Locks	Warranty: 12 Months, Unlimited Hours			
	Work Lights			
	X-Change (Attachment Mounting System)			
<b>A51 Option Package</b>	<b>M3219-P01-A51</b>	<b>1</b>	<b>\$4,916.00</b>	<b>\$4,916.00</b>
Cab Enclosure with Heat and Air Conditioning	Hydraulic X-Change			
Deluxe Cloth Suspension Seat				
Hydraulic Angle Blade	M3219-R12-C02	1	\$1,776.00	\$1,776.00
Travel Motion Alarm Kit	7205970	1	\$371.00	\$371.00
Strobe Light Kit	7172974	1	\$219.00	\$219.00
36" Base Class 4, Must order cutting edge.	M7020	1	\$0.00	\$0.00
--- 36" X-Change Severe Duty Trenching Bucket, Class 4	M7020-R01-C02	1	\$1,057.00	\$1,057.00
<b>Total of Items Quoted</b>				<b>\$52,472.00</b>
<b>Quote Total - US dollars</b>				<b>\$52,472.00</b>

Notes: Free 3 Year, 3,000 Hour Bobcat Engine Warranty (Promotion Good Through August 31, 2015)

All prices subject to change without prior notice or obligation. This price quote supersedes all preceding price quotes. Customer must exercise his purchase option within 30 days from quote date.

Customer Acceptance:

Purchase Order: \_\_\_\_\_

Authorized Signature:

Print: \_\_\_\_\_ Sign: \_\_\_\_\_ Date: \_\_\_\_\_

# EXCAVATOR SPECIFICATIONS

## E50 Excavator Machine Dimensions

- All dimensions are shown in inches. Respective metric dimensions are given in millimeters enclosed by parentheses.
  - Where applicable, specifications conform to SAE or ISO standards and are subject to change without notice.

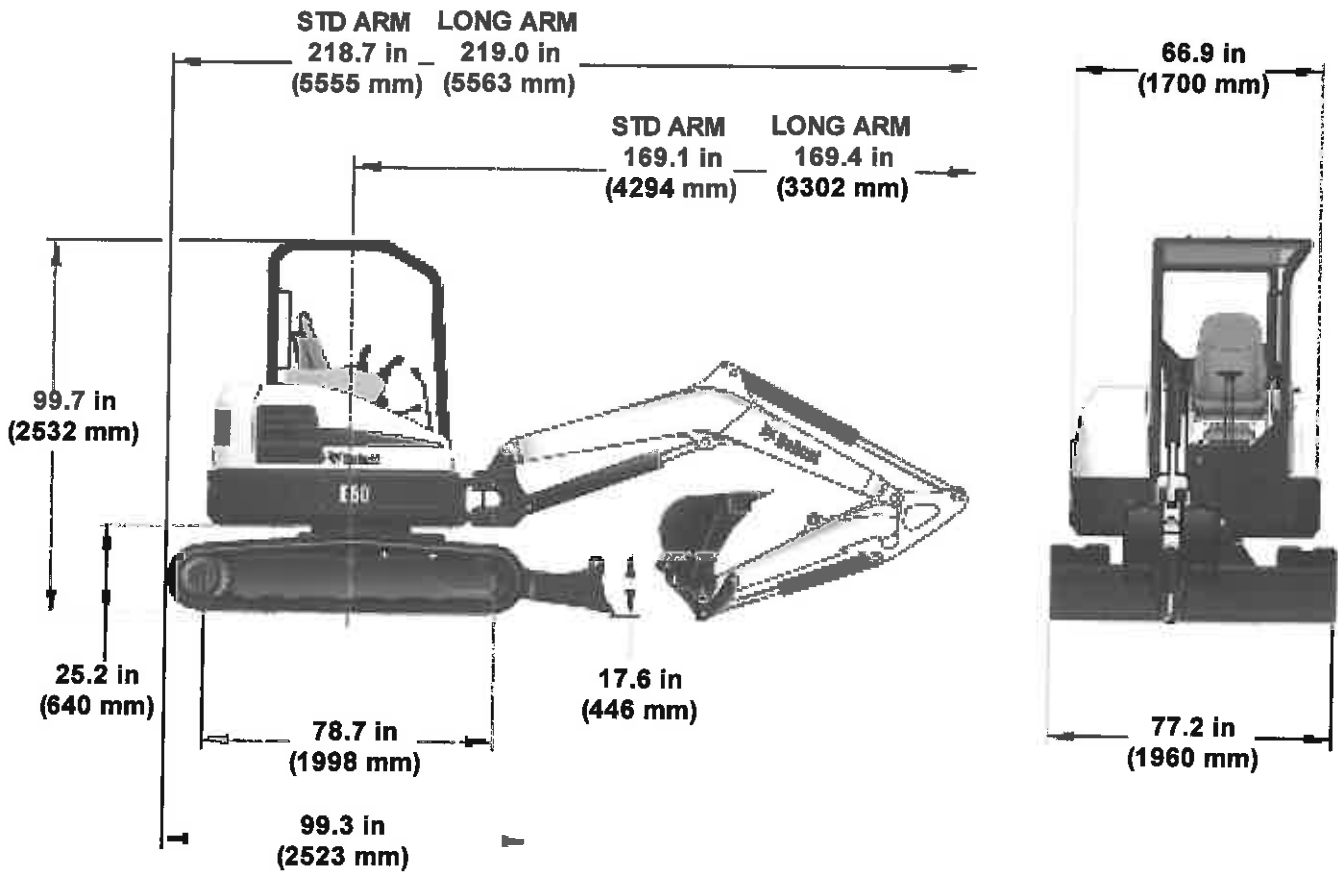
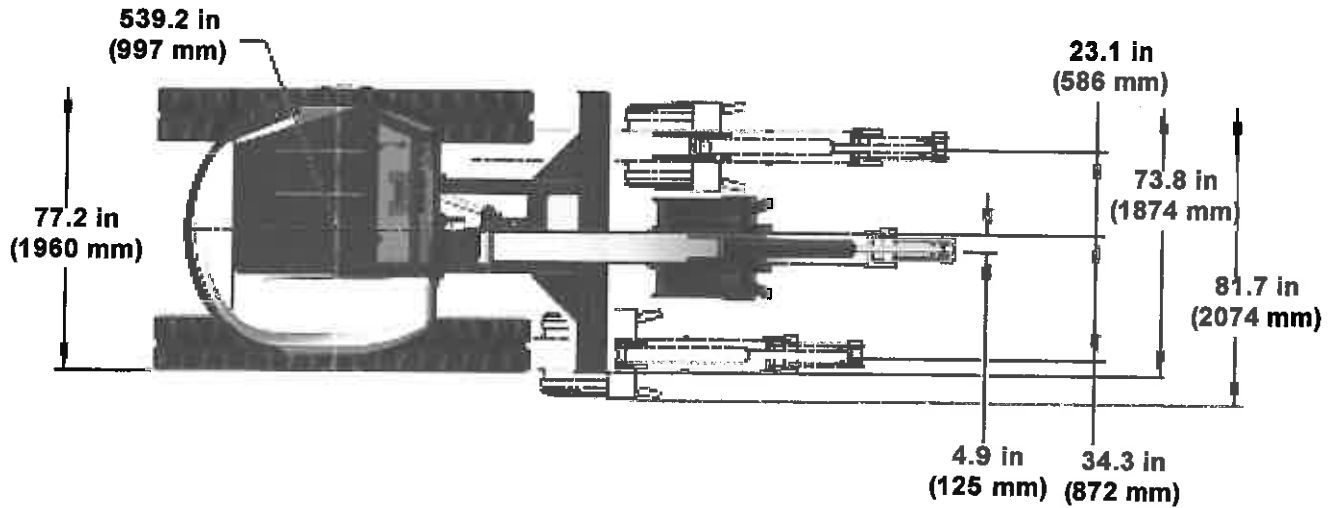

NA5066

*\*Specification(s) are based on engineering calculations and are not actual measurements. Specification(s) are provided for comparison purposes only and are subject to change without notice. Specification(s) for your individual Bobcat equipment will vary based on normal variations in design, manufacturing, operating conditions, and other factors.*

## EXCAVATOR SPECIFICATIONS (CONT'D)

### E50 Excavator Machine Dimensions - Standard Arm

- All dimensions are shown in inches. Respective metric dimensions are given in millimeters enclosed by parentheses.
- Where applicable, specifications conform to SAE or ISO standards and are subject to change without notice.

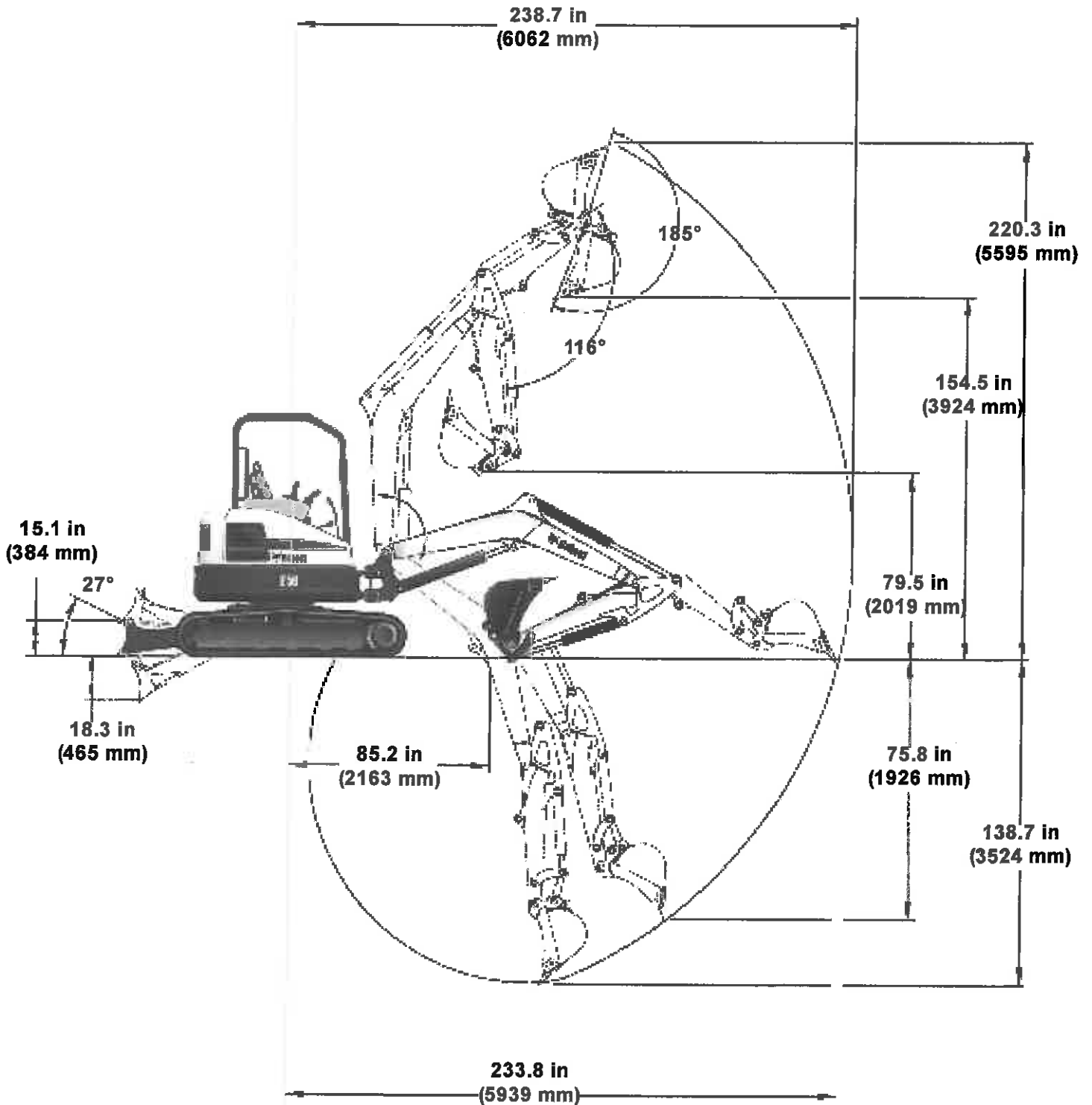

## EXCAVATOR SPECIFICATIONS (CONT'D)

### E50 Excavator Machine Dimensions - Long Arm

- All dimensions are shown in inches. Respective metric dimensions are given in millimeters enclosed by parentheses.
- Where applicable, specifications conform to SAE or ISO standards and are subject to change without notice.

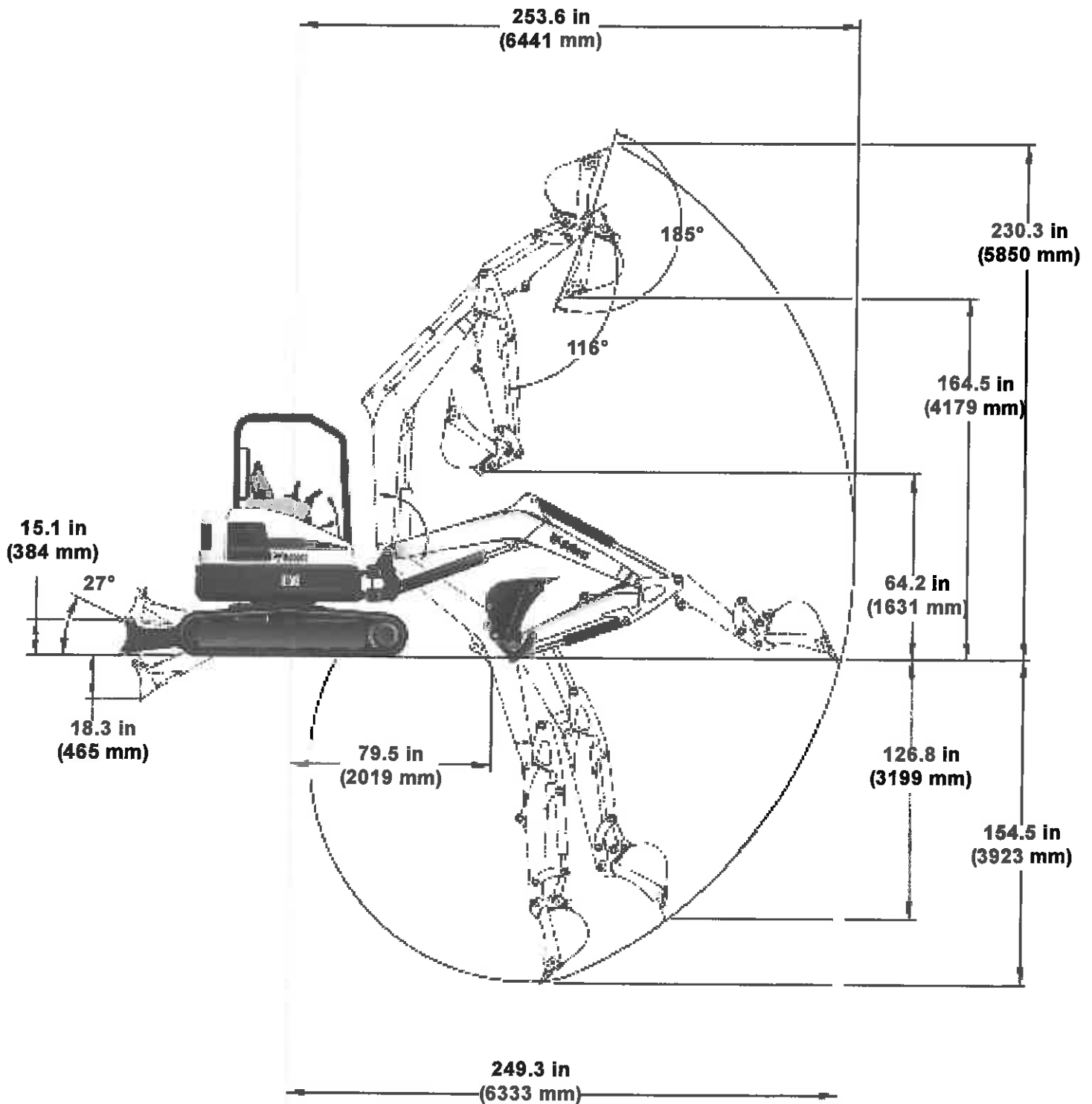

## EXCAVATOR SPECIFICATIONS (CONT'D)

### Performance

E50	
Operating weight (canopy w/ rubber tracks, and 24 in (610 mm) bucket)	10677 lb (4843 kg)
If equipped with the following, add:	Steel tracks, add 289 lb (131kg); Cab w/Heater, add 267 lb (121 kg); Cab w/HVAC, add 309 lb (140 kg); Long Arm (with additional counterweight), add 518 lb (235 kg); Additional Counterweight 450 lb (204 kg); Angle Blade, add 346 lb (157 kg) Hydraulic Clamp, add 270 lb (122 kg)
Travel Speed (Low / High)	1.9 mph / 3.1 mph (3,1 kph / 5,0 kph)
Digging Force (per ISO 6015)	
With Standard Arm	Arm - 6452 lbf (28700 N) Bucket - 9442 lbf (42000 N)
With Long Arm	Arm - 5868 lbf (26100 N) Bucket - 9442 lbf (42000 N)
Boom Swing	Left 75° Right 50°

### Controls

Steering	Two hand levers (optional foot pedals)
Hydraulics	Two hand operated levers (joysticks) control boom, bucket, arm and upperstructure slew
Blade	Hand lever
Angle Blade (If Equipped)	Switch on blade lever
Two Speed	Switch on blade lever
Boom Switch	Electric switch in left joystick
Auxiliary Hydraulics	Electric switch in right joystick
Auxiliary Pressure Release	Electric switch in right joystick
Engine	Engine speed control dial with auto idle feature, key type start switch
Starting Aid	Glow Plugs - activated by key switch
Brakes	
Travel	
Service & Parking	Hydraulic lock in motor circuit
Swing	
Service	Hydraulic lock on motor
Holding	Spring applied - hydraulic release

## EXCAVATOR SPECIFICATIONS (CONT'D)

### Engine

Make/Model	Kubota V2403-M-DI-TE3B-BC-4
Fuel/Cooling	Diesel / Liquid
Horsepower @ 2200 RPM (SAE Net)	47.5 hp (35,4 Kw)
Torque @ 1200 RPM (SAE Net)	132.4 ft-lb (179,5 N·m)
Number Of Cylinders	4
Displacement	148.5 ci (2,433 L)
Bore/Stroke	3.43 x 4.03 in (87,1 x 102,4 mm)
Lubrication	Pressure System with Filter
Crankcase Ventilation	Closed Breathing
Air Cleaner	Dry replaceable paper dual cartridge
Ignition	Diesel-Compression
Low Idle Speed	1200 rpm +/- 75 rpm
High Idle Speed	2450 rpm
Engine Coolant	Propylene Glycol / water mixture (53% PG / 47% water)

### Hydraulic System

Pump Type	Engine driven, single outlet, variable displacement, load sensing, torque limited, piston pump
Pump Capacity Piston Pump	36.6 U.S. gpm (138,5 Lpm)
Auxiliary Flow (Aux3)	20.0 U.S. gpm (75,7 Lpm)
Auxiliary Flow - 2nd Aux (Female coupler) (Male Coupler)	7.0 U.S. U.S. gpm (26,4 L/min) 5.5 U.S. gpm (21,0 L/min)
Hydraulic Filter	Full flow replaceable, 3 micron synthetic media element
Control Valve	closed center, individually compensated
System Relief Pressure Slew Circuit Boom, Blade, Arm, Bucket, Boom Swing, Auxiliary Joystick Control Pressure	3495 psi (24097 kPa) (241 bar) 3710 psi (25580 kPa) (256 bar) 435 psi (2999 kPa) (30 bar)
Auxiliary Port Relief, Male And Female Couplers	3045 psi (20995 kPa) (210 bar)
Case Drain	25 psi (172 kPa) (1,7 bar)



## EXCAVATOR SPECIFICATIONS (CONT'D)

### Hydraulic Cylinders

Cylinder	Bore	Rod	Stroke
Boom (cushion up)	4.00 in (101,6 mm)	2.25 in (57,1 mm)	27.45 in (697 mm)
Arm (cushion retract / extend)	3.50 in (88,9 mm)	2.25 in (57,1 mm)	29.82 in (757 mm)
Bucket	3.25 in (82,6 mm)	2.00 in (50,8 mm)	20.63 in (524 mm)
Boom Swing	3.75 in (95,2 mm)	2.00 in (50,8 mm)	19.32 in (491 mm)
Blade	4.00 in (101,6 mm)	2.00 in (50,8 mm)	7.68 in (195 mm)
Angle Blade (If equipped)	2.50 in (63,5 mm)	1.50 in (38,1 mm)	16.65 in (423 mm)

### Hydraulic Cycle Times

Bucket Curl	2.6 Seconds
Bucket Dump	1.8 Seconds
Arm Retract	3.1 Seconds
Arm Extend	3.1 Seconds
Boom Raise	4.8 Seconds
Boom Lower	4.6 Seconds
Boom Swing Left	8.8 Seconds
Boom Swing Right	8.1 Seconds
Blade Raise	3.1 Seconds
Blade Lower	2.7 Seconds
Angle Blade Left (If equipped)	1.8 Seconds
Angle Blade Right (If equipped)	1.8 Seconds

### Electrical

Starting Aid	Glow Plugs
Alternator	12 volts, 90 Amp open frame w/ internal regulator
Battery	12 volts - 530 CCA @ 00F (-180C)
Starter	12 volts; gear reduction 2.7 hp (2.0 kw)
Instrumentation	Fuel gauge, audible alarm, visual warning for engine functions and hourmeter
Lights	37.5 watt (2)

## EXCAVATOR SPECIFICATIONS (CONT'D)

### Drive System

Final Drive	Each track is driven by hydrostatic axial piston motor
Type of Reduction	56.4:1 two stage planetary

### Slew System

Slew Motor	Axial piston connected to a planetary drive
Slew Circle	Single row shear type ball bearing with internal gear
Slew Speed	9.0 rpm

### Undercarriage

Crawler Track Design	Sealed track rollers with boxed section track roller frame, grease type track adjuster with shock absorbing recoil spring
Width of crawler	77.2 in (1960 mm)

### Capacities

Fuel Tank	21.1 U.S. gal (79,9 L)
Hydraulic Reservoir Only (Center of Sight Glass)	Tank Cap. 4.0 U.S. gal (15,1 L)
Hydraulic System (with Reservoir)	14.5 U.S. gal (54,9 L)
Cooling System	2.2 U.S. gal (8,3 L)
Engine Oil and Filter	7.5 qt (7,1 L)
Final Drive (each)	1.1 qt (1,0 L)

### Tracks

Type	Rubber	Steel
Width	15.7 in (400 mm)	15.7 in (400 mm)
Number of Track Rollers (per side)	5	5

### Ground Pressure

Rubber Tracks - Standard Arm Long Arm	3.95 psi (27,2 kPa) (0,272 bar) 4.05 psi (27,9 kPa) (0,280 bar)
Steel Tracks - Standard Arm Long Arm	4.14 psi (28,5 kPa) (0,285 bar) 4.25 psi (29,3 kPa) (0,293 bar)

# Lift Charts

## Standard Arm

### WARNING

**OVERLOAD CAN TIP THE EXCAVATOR AND CAUSE INJURY OR DEATH**

- Do not lift or hold any load that exceeds these ratings at their specified load radii and height.
- Total rated load is shown. The weight of all lifting devices must be deducted to determine the net load that can be lifted.

Where applicable, specifications conform to ISO Standards. Specifications are subject to change without notice. Lift Point is bucket hinge point with standard bucket attached and bucket cylinder fully extended.

### EXCAVATOR MODEL E50

CIRCUIT PRESSURES	BOOM LENGTH	2775 mm (109.3 in)
WORKING 250 bar (3625 psi)	ARM LENGTH	1625 mm (60.0 in)
HOLDING 280 bar (4205 psi)	COUNTERWEIGHT	750 kg (1653 lb)
	STANDARD BUCKET	610 mm (24.0 in)
		142 kg (313 lb)

LIFT POINT HEIGHT	RATED LIFT CAPACITY OVER BLADE, BLADE DOWN - kg (lb)			RATED LIFT CAPACITY OVER BLADE, BLADE UP - kg (lb)			RATED LIFT CAPACITY OVER SIDE, BLADE UP - kg (lb)		
	LIFT RADIUS - mm (in)			LIFT RADIUS - mm (in)			LIFT RADIUS - mm (in)		
	2000 (78.7)	3000 (118.1)	4000 (157.5)	2000 (78.7)	3000 (118.1)	4000 (157.5)	2000 (78.7)	3000 (118.1)	4000 (157.5)
4000 (157.5)			*967 (2131) LIFT @ MAXIMUM RADIUS kg (lb) @ mm (in) @ 4075 (160)			*967 (2131) LIFT @ MAXIMUM RADIUS kg (lb) @ mm (in) @ 4075 (160)			562 (1239) LIFT @ MAXIMUM RADIUS kg (lb) @ mm (in) @ 4075 (160)
3000 (118.1)			*979 (2168) LIFT @ MAXIMUM RADIUS kg (lb) @ mm (in) @ 4850 (191)			749 (1662) LIFT @ MAXIMUM RADIUS kg (lb) @ mm (in) @ 4850 (191)			560 (1235) LIFT @ MAXIMUM RADIUS kg (lb) @ mm (in) @ 4850 (191)
2000 (78.7)		*1603 (3534) LIFT @ MAXIMUM RADIUS kg (lb) @ mm (in) @ 2746	*1246 (2746) LIFT @ MAXIMUM RADIUS kg (lb) @ mm (in) @ 5250 (207)		1181 (2606) LIFT @ MAXIMUM RADIUS kg (lb) @ mm (in) @ 708 (1561)	708 (1561) LIFT @ MAXIMUM RADIUS kg (lb) @ mm (in) @ 5250 (207)		886 (1954) LIFT @ MAXIMUM RADIUS kg (lb) @ mm (in) @ 537 (1185)	537 (1185) LIFT @ MAXIMUM RADIUS kg (lb) @ mm (in) @ 6250 (207)
1000 (39.4)		*2454 (5411) LIFT @ MAXIMUM RADIUS kg (lb) @ mm (in) @ 3438	*1569 (3438) LIFT @ MAXIMUM RADIUS kg (lb) @ mm (in) @ 5325 (210)		1028 (2268) LIFT @ MAXIMUM RADIUS kg (lb) @ mm (in) @ 658 (1460)	658 (1460) LIFT @ MAXIMUM RADIUS kg (lb) @ mm (in) @ 5325 (210)		794 (1750) LIFT @ MAXIMUM RADIUS kg (lb) @ mm (in) @ 485 (1071)	485 (1071) LIFT @ MAXIMUM RADIUS kg (lb) @ mm (in) @ 5325 (210)
Ground		*2737 (6034) LIFT @ MAXIMUM RADIUS kg (lb) @ mm (in) @ 1760 (3880)	*1760 (3880) LIFT @ MAXIMUM RADIUS kg (lb) @ mm (in) @ 5175 (204)		1013 (2234) LIFT @ MAXIMUM RADIUS kg (lb) @ mm (in) @ 635 (1399)	635 (1399) LIFT @ MAXIMUM RADIUS kg (lb) @ mm (in) @ 5175 (204)		730 (1610) LIFT @ MAXIMUM RADIUS kg (lb) @ mm (in) @ 451 (996)	451 (996) LIFT @ MAXIMUM RADIUS kg (lb) @ mm (in) @ 5175 (204)
-1000 (-39.4)	*4023 (8870) LIFT @ MAXIMUM RADIUS kg (lb) @ mm (in) @ 2652 (5847)	*2652 (5847) LIFT @ MAXIMUM RADIUS kg (lb) @ mm (in) @ 3755	*1717 (3755) LIFT @ MAXIMUM RADIUS kg (lb) @ mm (in) @ 4705 (185)	*1341 (2956) LIFT @ MAXIMUM RADIUS kg (lb) @ mm (in) @ 4705 (185)	1988 (4384) LIFT @ MAXIMUM RADIUS kg (lb) @ mm (in) @ 944 (2082)	944 (2082) LIFT @ MAXIMUM RADIUS kg (lb) @ mm (in) @ 627 (1382)	490 (1081) LIFT @ MAXIMUM RADIUS kg (lb) @ mm (in) @ 4705 (185)	1378 (3039) LIFT @ MAXIMUM RADIUS kg (lb) @ mm (in) @ 734 (1620)	454 (1002) LIFT @ MAXIMUM RADIUS kg (lb) @ mm (in) @ 343 (757)

\* Rated Hydraulic Lift Capacity 76623 SW 7106434 enUS

## Standard Arm - Add-on Counterweight

### WARNING

**OVERLOAD CAN TIP THE EXCAVATOR AND CAUSE INJURY OR DEATH**

- Do not lift or hold any load that exceeds these ratings at their specified load radii and height.
- Total rated load is shown. The weight of all lifting devices must be deducted to determine the net load that can be lifted.

Where applicable, specifications conform to ISO Standards. Specifications are subject to change without notice. Lift Point is bucket hinge point with standard bucket attached and bucket cylinder fully extended.

### EXCAVATOR MODEL E50

CIRCUIT PRESSURES	BOOM LENGTH	2775 mm (109.3 in)
WORKING 250 bar (3625 psi)	ARM LENGTH	1625 mm (60.0 in)
HOLDING 280 bar (4205 psi)	COUNTERWEIGHT	970 kg (2138 lb)
	STANDARD BUCKET	610 mm (24.0 in)
		142 kg (313 lb)

LIFT POINT HEIGHT	RATED LIFT CAPACITY OVER BLADE, BLADE DOWN - kg (lb)			RATED LIFT CAPACITY OVER BLADE, BLADE UP - kg (lb)			RATED LIFT CAPACITY OVER SIDE, BLADE UP - kg (lb)		
	LIFT RADIUS - mm (in)			LIFT RADIUS - mm (in)			LIFT RADIUS - mm (in)		
	2000 (78.7)	3000 (118.1)	4000 (157.5)	2000 (78.7)	3000 (118.1)	4000 (157.5)	2000 (78.7)	3000 (118.1)	4000 (157.5)
4000 (157.5)			*967 (2131) LIFT @ MAXIMUM RADIUS kg (lb) @ mm (in) @ 4075 (160)			*967 (2131) LIFT @ MAXIMUM RADIUS kg (lb) @ mm (in) @ 4075 (160)			635 (1399) LIFT @ MAXIMUM RADIUS kg (lb) @ mm (in) @ 4075 (160)
3000 (118.1)			*979 (2168) LIFT @ MAXIMUM RADIUS kg (lb) @ mm (in) @ 4850 (191)			593 (1307) LIFT @ MAXIMUM RADIUS kg (lb) @ mm (in) @ 4850 (191)			654 (1442) LIFT @ MAXIMUM RADIUS kg (lb) @ mm (in) @ 4850 (191)
2000 (78.7)		*1603 (3534) LIFT @ MAXIMUM RADIUS kg (lb) @ mm (in) @ 2746	*1246 (2746) LIFT @ MAXIMUM RADIUS kg (lb) @ mm (in) @ 5250 (207)		1181 (2606) LIFT @ MAXIMUM RADIUS kg (lb) @ mm (in) @ 818 (1804)	818 (1804) LIFT @ MAXIMUM RADIUS kg (lb) @ mm (in) @ 5250 (207)		818 (2023) LIFT @ MAXIMUM RADIUS kg (lb) @ mm (in) @ 577 (1273)	577 (1273) LIFT @ MAXIMUM RADIUS kg (lb) @ mm (in) @ 6250 (207)
1000 (39.4)		*2454 (5411) LIFT @ MAXIMUM RADIUS kg (lb) @ mm (in) @ 3438	*1569 (3438) LIFT @ MAXIMUM RADIUS kg (lb) @ mm (in) @ 5325 (210)		1158 (2554) LIFT @ MAXIMUM RADIUS kg (lb) @ mm (in) @ 765 (1686)	765 (1686) LIFT @ MAXIMUM RADIUS kg (lb) @ mm (in) @ 5325 (210)		822 (1813) LIFT @ MAXIMUM RADIUS kg (lb) @ mm (in) @ 531 (1172)	531 (1172) LIFT @ MAXIMUM RADIUS kg (lb) @ mm (in) @ 5325 (210)
Ground		*2737 (6034) LIFT @ MAXIMUM RADIUS kg (lb) @ mm (in) @ 1760 (3880)	*1760 (3880) LIFT @ MAXIMUM RADIUS kg (lb) @ mm (in) @ 5175 (204)		1082 (2386) LIFT @ MAXIMUM RADIUS kg (lb) @ mm (in) @ 721 (1591)	721 (1591) LIFT @ MAXIMUM RADIUS kg (lb) @ mm (in) @ 5175 (204)		746 (1644) LIFT @ MAXIMUM RADIUS kg (lb) @ mm (in) @ 520 (1147)	520 (1147) LIFT @ MAXIMUM RADIUS kg (lb) @ mm (in) @ 5175 (204)
-1000 (-39.4)	*4023 (8870) LIFT @ MAXIMUM RADIUS kg (lb) @ mm (in) @ 2652 (5847)	*2652 (5847) LIFT @ MAXIMUM RADIUS kg (lb) @ mm (in) @ 3755	*1717 (3755) LIFT @ MAXIMUM RADIUS kg (lb) @ mm (in) @ 4705 (185)	*1341 (2956) LIFT @ MAXIMUM RADIUS kg (lb) @ mm (in) @ 4705 (185)	2329 (5134) LIFT @ MAXIMUM RADIUS kg (lb) @ mm (in) @ 1090 (2403)	1090 (2403) LIFT @ MAXIMUM RADIUS kg (lb) @ mm (in) @ 723 (1593)	568 (1248) LIFT @ MAXIMUM RADIUS kg (lb) @ mm (in) @ 4705 (185)	1438 (3170) LIFT @ MAXIMUM RADIUS kg (lb) @ mm (in) @ 768 (1695)	512 (1130) LIFT @ MAXIMUM RADIUS kg (lb) @ mm (in) @ 401 (885)

\* Rated Hydraulic Lift Capacity 77741 SW 7189442A enUS