



# West Virginia Purchasing Division

2019 Washington Street, East  
Charleston, WV 25305  
Telephone: 304-558-2306  
General Fax: 304-558-6026  
Bid Fax: 304-558-3970

The following documentation is an electronically-submitted vendor response to an advertised solicitation from the *West Virginia Purchasing Bulletin* within the Vendor Self-Service portal at ***wvOASIS.gov***. As part of the State of West Virginia's procurement process, and to maintain the transparency of the bid-opening process, this documentation submitted online is publicly posted by the West Virginia Purchasing Division at ***WVPurchasing.gov*** with any other vendor responses to this solicitation submitted to the Purchasing Division in hard copy format.

## Header

List View

**General Information** | [Contact](#) | [Default Values](#) | [Discount](#) | [Document Information](#)

Procurement Folder: 104718

Procurement Type: Central Purchase Order

Vendor ID: 000000103427 

Legal Name: GRAYBAR ELECTRIC CO INC

Alias/DBA:

Total Bid: \$82,125.00

Response Date: 09/22/2015 

Response Time: 8:37

SO Doc Code: CRFQ

SO Dept: 0211

SO Doc ID: GSD1600000007

Published Date: 9/8/15

Close Date: 9/22/15

Close Time: 13:30

Status: Closed

Solicitation Description: Addendum #1 Capitol Campus  
Holophane Lights

Total of Header Attachments: 0

Total of All Attachments: 0



Purchasing Division  
 2019 Washington Street East  
 Post Office Box 50130  
 Charleston, WV 25305-0130

State of West Virginia  
 Solicitation Response

Proc Folder : 104718

Solicitation Description : Addendum #1 Capitol Campus Holophane Lights

Proc Type : Central Purchase Order

Date issued	Solicitation Closes	Solicitation No	Version
	2015-09-22 13:30:00	SR 0211 ESR09221500000001228	1

**VENDOR**

000000103427  
 GRAYBAR ELECTRIC CO INC

**FOR INFORMATION CONTACT THE BUYER**

Laura E Hooper  
 (304) 558-0468  
 laura.e.hooper@wv.gov

Signature X FEIN # DATE

All offers subject to all terms and conditions contained in this solicitation

Line	Comm Ln Desc	Qty	Unit Issue	Unit Price	Ln Total Or Contract Amount
1	Holophane Granville II Lamp Post or equal	75.00000	EA	\$1,095.000000	\$82,125.00

Comm Code	Manufacturer	Specification	Model #
39100000			

**Extended Description :** The West Virginia Purchasing Division is soliciting bids on behalf of the WV Department of Administration, General Services Division, to establish a contract for the "One-Time" purchase of seventy-five (75) Holophane, Granville II, LED Lamppost light fixtures, Model # GPD805KASMB5NRB, or Equal, to match existing, installed lamppost fixtures on the campus of the WV State Capitol Complex in Charleston, WV, per the specifications, and terms and conditions included herein.



Purchasing Division  
 2019 Washington Street East  
 Post Office Box 50130  
 Charleston, WV 25305-0130

State of West Virginia  
 Request for Quotation

Proc Folder: 104718

Doc Description: Capitol Campus Holophane Lights

Proc Type: Central Purchase Order

Date Issued	Solicitation Closes	Solicitation No	Version
2015-08-13	2015-09-22 13:30:00	CRFQ 0211 GSD1600000007	1

**BID RECEIVING LOCATION**

BID CLERK  
 DEPARTMENT OF ADMINISTRATION  
 PURCHASING DIVISION  
 2019 WASHINGTON ST E  
 CHARLESTON WV 25305  
 US

**VENDOR**

Vendor Name, Address and Telephone Number:

**FOR INFORMATION CONTACT THE BUYER**

Laura E Hooper  
 (304) 558-0468  
 laura.e.hooper@wv.gov

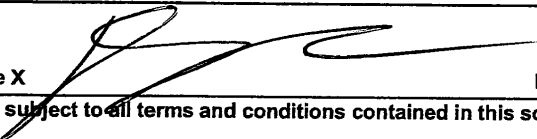
Signature X  FEIN # 13079438001 DATE 9/22/15

All offers subject to all terms and conditions contained in this solicitation

INVOICE TO		SHIP TO	
DEPARTMENT OF ADMINISTRATION GENERAL SERVICES DIVISION 1900 KANAWHA BLVD E, BLDG 1, RM MB-68 CHARLESTON WV25305 US		DEPARTMENT OF ADMINISTRATION GENERAL SERVICES DIVISION 1900 KANAWHA BLVD E, BLDG 1 RM MB12 CHARLESTON WV 25305 US	

Line	Comm Ln Desc	Qty	Unit Issue	Unit Price	Total Price
1	Holophane Granville II Lamp Post or equal	75.00000	EA		

Comm Code	Manufacturer	Specification	Model #
39100000	PHILIPS HADCO	RL54-L-B-N-F-I-A-N-C-64-A-N	

**Extended Description :**

The West Virginia Purchasing Division is soliciting bids on behalf of the WV Department of Administration, General Services Division, to establish a contract for the "One-Time" purchase of seventy-five (75) Holophane, Granville II, LED Lamppost light fixtures, Model # GPD805KASMB5NRB, or Equal, to match existing, installed lamppost fixtures on the campus of the WV State Capitol Complex in Charleston, WV, per the specifications, and terms and conditions included herein.

Holophane Granville II Lamp Post or equal

REQUEST FOR QUOTATION  
Purchase of LED Lamppost Light Fixtures

---

**SPECIFICATIONS**

1. **PURPOSE AND SCOPE:** The West Virginia Purchasing Division is soliciting bids on behalf of the WV Department of Administration, General Services Division, to establish a contract for the "One-Time" purchase of seventy-five (75) Holophane, Granville II, LED Lamppost light fixtures, Model #GPD805KASMB5NRB, or Equal, to match existing, installed lamppost fixtures on the campus of the WV. State Capitol Complex in Charleston, WV, per the specifications included herein.
  
2. **DEFINITIONS:** The terms listed below shall have the meanings assigned to them below. Additional definitions can be found in section 2 of the General Terms and Conditions.
  - 2.1 **"Desired Item"** means the Holophane Granville II LED lamppost light fixture, or Equal, as designated by the specifications herein.
  - 2.2 **"Pricing Page"** means the pages, contained in wvOASIS or attached as Exhibit "A", upon which the Vendor should list its proposed price for the Contract items.
  - 2.3 **"Solicitation"** means the official notice of an opportunity to supply the State with goods or services that is published by the Purchasing Division.
  - 2.4 **"Tenon"** is the top of the lamppost that the slip fitter connects to.
  - 2.5 **"Slip fitter"** is the section that connects the light fixture to the tenon.
  
3. **GENERAL REQUIREMENTS:**
  - 3.1 **Mandatory Contract Item Requirements:** Contract Item must meet or exceed the mandatory requirements listed below.
    - 3.1.1 Holophane Granville II LED lamppost light fixtures, Model#GPD805KASMB5NRB, or Equal, as follows:
      - 3.1.1.1 Light fixture must have housing of (powder-coated) black finish aluminum with ribs matching the Granville Premier Utility housing (to match exactly those already installed on the Capitol Campus). Installed lamppost fixtures are located along California Avenue, Charleston, WV.
      - 3.1.1.2 Fixture must be LED, with IES Type V Distribution Optics (The optical system consists of precisely molded thermal resistant

REQUEST FOR QUOTATION  
Purchase of LED Lamppost Light Fixtures

---

borosilicate glass refractor and top reflector mounted within the decorative aluminum housing. The glass top reflector redirects over 50% of the upward light into the controlling refractor while allowing a soft up light component to define the traditional acorn shape of the luminaire. The lower refractor uses precisely molded prisms to maximize pole spacing's while maintaining uniform illuminance), with:

- 5000 K Color Temperature
- 80W (420mA) LED Ballast (driver)
- Auto-sensing voltage (120-277V)

**3.1.1.3** Fixture (and fixture cost) must include slip fitter for 3" Tenon to be compatible with lampposts existing on campus.

**3.1.1.4** Refractor and reflector must be single unit, symmetric Type V (see 3.1.1.2) style, in an "acorn" shape, and:

- Have no trim (no bars, bands, cover, etc).
- Be topped with a powder coated (black) aluminum "cross"-style finial.
- Be composed of molded glass (not plastic)

#### **4. CONTRACT AWARD:**

**4.1 Contract Award:** The Contract is intended to provide Agencies with a purchase price for the Contract Items. The Contract shall be awarded to the Vendor that provides the Contract Items meeting the required specifications for the lowest overall total cost as shown on the Pricing Page.

**4.2** If alternate brand and model is bid, this information should be noted on the Vendor's Exhibit "A" Pricing Page at the time of submittal and prior to bid opening.

**4.3** The Vendor should provide backup documentation (product brochures) to substantiate that alternate meets specification. Any alternate must visually



REQUEST FOR QUOTATION  
Purchase of LED Lamppost Light Fixtures

---

match the most recently installed fixtures (see fixtures along California Avenue, Charleston, WV.) on the lampposts of the campus, to ensure homogenous aesthetic, including the fixture housing and all aspects of the refractor/reflector.

Documentation information should be submitted with the Vendor's submitted bid but will be required before award of Contract.

**4.4 Pricing Page:** Vendor should complete the Pricing Page by bidding the price for the entire fixture, including housing, refractor and the slip fitter.

Vendor should complete the Pricing Page in full as failure to complete the Pricing Page in its entirety may result in Vendor's bid being disqualified.

Vendor should type or electronically enter the information into the Pricing Page to prevent errors in the evaluation.

**5. PAYMENT:**

**5.1 Payment:** Vendor shall accept payment in accordance with the payment procedures of the State of West Virginia.

**5.2** Invoices shall be submitted for payment (in arrears) and must include the following information.

**5.1.1** Invoices must include invoice date, delivery date, FEIN number, complete address of vendor and contractor number.

**5.2.2** Invoices shall be emailed to [gsdinvoices@wv.gov](mailto:gsdinvoices@wv.gov) or mailed to the following address:

General Services Division  
1900 Kanawha Blvd. East  
Building 1, Room MB-68  
Charleston, WV 25305

**5.2.3** Any equipment or material contracted for prior to receipt of the signed purchase order shall be at the Bidder's risk.

REQUEST FOR QUOTATION  
Purchase of LED Lamppost Light Fixtures

---

**6. DELIVERY AND RETURN:**

**6.1 Shipment and Delivery:** Vendor shall ship the Contract Items immediately after being awarded this Contract and receiving a purchase order or notice to proceed. Vendor shall deliver the Contract Items within forty-five (45) calendar days after receiving a purchase order or notice to proceed. Contract Items must be delivered to Agency at 215 Piedmont Road, Charleston, WV 25301.

**6.2 Late Delivery:** The Agency placing the order under this Contract must be notified in writing if the shipment of the Contract Items will be delayed for any reason. Any delay in delivery that could cause harm to an Agency will be grounds for cancellation of the Contract, and/or obtaining the Contract Items from a third party.

Any Agency seeking to obtain the Contract Items from a third party under this provision must first obtain approval of the Purchasing Division.

**6.3 Delivery Payment/Risk of Loss:** Vendor shall deliver the Contract Items F.O.B. destination to the Agency's location.

**6.4 Return of Unacceptable Items:** If the Agency deems the Contract Items to be unacceptable, the Contract Items shall be returned to Vendor at Vendor's expense and with no restocking charge. Vendor shall either make arrangements for the return within five (5) days of being notified that items are unacceptable, or permit the Agency to arrange for the return and reimburse Agency for delivery expenses. If the original packaging cannot be utilized for the return, Vendor will supply the Agency with appropriate return packaging upon request. All returns of unacceptable items shall be F.O.B. the Agency's location. The returned product shall either be replaced, or the Agency shall receive a full credit or refund for the purchase price, at the Agency's discretion.

**6.5 Return Due to Agency Error:** Items ordered in error by the Agency will be returned for credit within 30 days of receipt, F.O.B. Vendor's location. Vendor shall not charge a restocking fee if returned products are in a resalable condition. Items shall be deemed to be in a resalable condition if they are unused and in the original packaging. Any restocking fee for items not in a resalable condition shall be the lower of the Vendor's customary restocking fee or 5% of the total invoiced value of the returned items.

**7 VENDOR DEFAULT:**

**7.1** The following shall be considered a vendor default under this Contract.

**REQUEST FOR QUOTATION**  
**Purchase of LED Lamppost Light Fixtures**

---

- 7.1.1 Failure to provide Contract Items in accordance with the requirements contained herein.
  - 7.1.2 Failure to comply with other specifications and requirements contained herein.
  - 7.1.3 Failure to comply with any laws, rules, and ordinances applicable to the Contract Services provided under this Contract.
  - 7.1.4 Failure to remedy deficient performance upon request.
- 7.2 The following remedies shall be available to Agency upon default.
- 7.2.1 Immediate cancellation of the Contract.
  - 7.2.2 Immediate cancellation of one or more release orders issued under this Contract.
  - 7.2.3 Any other remedies available in law or equity.

State of West Virginia  
General Services Division  
Attachment A: Pricing Page

LED Lamppost Light Fixtures  
CRFQ - GSD160000007

---

GENERAL SERVICES DIVISION  
LED LAMPPOST LIGHT FIXTURES

**Pricing Page**

NAME OF BIDDER: Graybar Electric Co.

We, the BIDDER, having examined specifications, hereby propose to furnish equipment as described in the Bidding Documents.

**Total Cost to provide equipment as stipulated in the Bidding Documents:**

Eighty-two thousand - One Hundred Twenty-Five  
and xx/100 Dollars (\$ 82,125.<sup>00</sup>)  
(Total to be written in figures and words.)

In the event that the written amount and the numerical amount differ, the written amount shall prevail.

The Bidder, if successful and awarded the contract, agrees that equipment is to be delivered within forty-five (45) consecutive calendar days following issuance of the Purchase Order.

**CERTIFICATION AND SIGNATURE PAGE**

By signing below, or submitting documentation through wvOASIS, I certify that I have reviewed this Solicitation in its entirety; understand the requirements, terms and conditions, and other information contained herein; that I am submitting this bid, offer or proposal for review and consideration; that I am authorized by the vendor to execute and submit this bid, offer, or proposal, or any documents related thereto on vendor's behalf; that I am authorized to bind the vendor in a contractual relationship; and that to the best of my knowledge, the vendor has properly registered with any State agency that may require registration.

Graybar Electric Co.  
(Company)

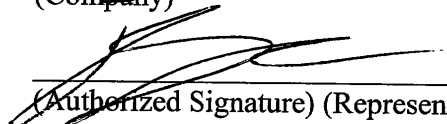
  
(Authorized Signature) (Representative Name, Title)

304-344-7371 304-344-0324 9/21/15  
(Phone Number) (Fax Number) (Date)

Rev. 04/14

## State of West Virginia VENDOR PREFERENCE CERTIFICATE

Certification and application\* is hereby made for Preference in accordance with **West Virginia Code, §5A-3-37**. (Does not apply to construction contracts). **West Virginia Code, §5A-3-37**, provides an opportunity for qualifying vendors to request (at the time of bid) preference for their residency status. Such preference is an evaluation method only and will be applied only to the cost bid in accordance with the **West Virginia Code**. This certificate for application is to be used to request such preference. The Purchasing Division will make the determination of the Vendor Preference, if applicable.

**1. Application is made for 2.5% vendor preference for the reason checked:**

- Bidder is an individual resident vendor and has resided continuously in West Virginia for four (4) years immediately preceding the date of this certification; **or**,
- Bidder is a partnership, association or corporation resident vendor and has maintained its headquarters or principal place of business continuously in West Virginia for four (4) years immediately preceding the date of this certification; **or** 80% of the ownership interest of Bidder is held by another individual, partnership, association or corporation resident vendor who has maintained its headquarters or principal place of business continuously in West Virginia for four (4) years immediately preceding the date of this certification; **or**,
- Bidder is a nonresident vendor which has an affiliate or subsidiary which employs a minimum of one hundred state residents and which has maintained its headquarters or principal place of business within West Virginia continuously for the four (4) years immediately preceding the date of this certification; **or**,

**2. Application is made for 2.5% vendor preference for the reason checked:**

- Bidder is a resident vendor who certifies that, during the life of the contract, on average at least 75% of the employees working on the project being bid are residents of West Virginia who have resided in the state continuously for the two years immediately preceding submission of this bid; **or**,

**3. Application is made for 2.5% vendor preference for the reason checked:**

- Bidder is a nonresident vendor employing a minimum of one hundred state residents or is a nonresident vendor with an affiliate or subsidiary which maintains its headquarters or principal place of business within West Virginia employing a minimum of one hundred state residents who certifies that, during the life of the contract, on average at least 75% of the employees or Bidder's affiliate's or subsidiary's employees are residents of West Virginia who have resided in the state continuously for the two years immediately preceding submission of this bid; **or**,

**Application is made for 5% vendor preference for the reason checked:**

Bidder meets either the requirement of both subdivisions (1) and (2) or subdivision (1) and (3) as stated above; **or**,

**5. Application is made for 3.5% vendor preference who is a veteran for the reason checked:**

- Bidder is an individual resident vendor who is a veteran of the United States armed forces, the reserves or the National Guard and has resided in West Virginia continuously for the four years immediately preceding the date on which the bid is submitted; **or**,

**6. Application is made for 3.5% vendor preference who is a veteran for the reason checked:**

- Bidder is a resident vendor who is a veteran of the United States armed forces, the reserves or the National Guard, if, for purposes of producing or distributing the commodities or completing the project which is the subject of the vendor's bid and continuously over the entire term of the project, on average at least seventy-five percent of the vendor's employees are residents of West Virginia who have resided in the state continuously for the two immediately preceding years.

**7. Application is made for preference as a non-resident small, women- and minority-owned business, in accordance with West Virginia Code §5A-3-59 and West Virginia Code of State Rules.**

- Bidder has been or expects to be approved prior to contract award by the Purchasing Division as a certified small, women- and minority-owned business.

Bidder understands if the Secretary of Revenue determines that a Bidder receiving preference has failed to continue to meet the requirements for such preference, the Secretary may order the Director of Purchasing to: (a) reject the bid; or (b) assess a penalty against such Bidder in an amount not to exceed 5% of the bid amount and that such penalty will be paid to the contracting agency or deducted from any unpaid balance on the contract or purchase order.

By submission of this certificate, Bidder agrees to disclose any reasonably requested information to the Purchasing Division and authorizes the Department of Revenue to disclose to the Director of Purchasing appropriate information verifying that Bidder has paid the required business taxes, provided that such information does not contain the amounts of taxes paid nor any other information deemed by the Tax Commissioner to be confidential.

**Under penalty of law for false swearing (West Virginia Code, §61-5-3), Bidder hereby certifies that this certificate is true and accurate in all respects; and that if a contract is issued to Bidder and if anything contained within this certificate changes during the term of the contract, Bidder will notify the Purchasing Division in writing immediately.**

Bidder: Graybar Electric Co

Signed: George M. [Signature]

Date: 9/21/15

Title: QUOTATIONS COORDINATOR

RFQ No. GSD1600000007

STATE OF WEST VIRGINIA  
Purchasing Division

**PURCHASING AFFIDAVIT**

**MANDATE:** Under W. Va. Code §5A-3-10a, no contract or renewal of any contract may be awarded by the state or any of its political subdivisions to any vendor or prospective vendor when the vendor or prospective vendor or a related party to the vendor or prospective vendor is a debtor and: (1) the debt owed is an amount greater than one thousand dollars in the aggregate; or (2) the debtor is in employer default.

**EXCEPTION:** The prohibition listed above does not apply where a vendor has contested any tax administered pursuant to chapter eleven of the W. Va. Code, workers' compensation premium, permit fee or environmental fee or assessment and the matter has not become final or where the vendor has entered into a payment plan or agreement and the vendor is not in default of any of the provisions of such plan or agreement.

**DEFINITIONS:**

**"Debt"** means any assessment, premium, penalty, fine, tax or other amount of money owed to the state or any of its political subdivisions because of a judgment, fine, permit violation, license assessment, defaulted workers' compensation premium, penalty or other assessment presently delinquent or due and required to be paid to the state or any of its political subdivisions, including any interest or additional penalties accrued thereon.

**"Employer default"** means having an outstanding balance or liability to the old fund or to the uninsured employers' fund or being in policy default, as defined in W. Va. Code § 23-2c-2, failure to maintain mandatory workers' compensation coverage, or failure to fully meet its obligations as a workers' compensation self-insured employer. An employer is not in employer default if it has entered into a repayment agreement with the Insurance Commissioner and remains in compliance with the obligations under the repayment agreement.

**"Related party"** means a party, whether an individual, corporation, partnership, association, limited liability company or any other form or business association or other entity whatsoever, related to any vendor by blood, marriage, ownership or contract through which the party has a relationship of ownership or other interest with the vendor so that the party will actually or by effect receive or control a portion of the benefit, profit or other consideration from performance of a vendor contract with the party receiving an amount that meets or exceeds five percent of the total contract amount.

**AFFIRMATION:** By signing this form, the vendor's authorized signer affirms and acknowledges under penalty of law for false swearing (W. Va. Code §61-5-3) that neither vendor nor any related party owe a debt as defined above and that neither vendor nor any related party are in employer default as defined above, unless the debt or employer default is permitted under the exception above.

**WITNESS THE FOLLOWING SIGNATURE:**

Vendor's Name: Graybar Electric Co  
Authorized Signature: George M. [Signature] Date: 9-21-15

State of West Virginia

County of Kanawha, to-wit:

Taken, subscribed, and sworn to before me this 21<sup>st</sup> day of September, 2015.

My Commission expires Feb 1<sup>st</sup>, 2021.

**AFFIX SEAL HERE**

**NOTARY PUBLIC**

James L. Hundley  
Purchasing Affidavit (Revised 07/01/2012)

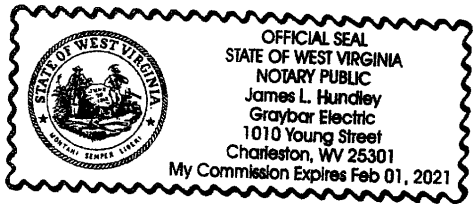

**ADDENDUM ACKNOWLEDGEMENT FORM**  
**SOLICITATION NO.: GSD160000007**

**Instructions:** Please acknowledge receipt of all addenda issued with this solicitation by completing this addendum acknowledgment form. Check the box next to each addendum received and sign below. Failure to acknowledge addenda may result in bid disqualification.

**Acknowledgment:** I hereby acknowledge receipt of the following addenda and have made the necessary revisions to my proposal, plans and/or specification, etc.

**Addendum Numbers Received:**

(Check the box next to each addendum received)

- |  |  |
|--|--|
| <input checked="" type="checkbox"/> Addendum No. 1 | <input type="checkbox"/> Addendum No. 6  |
| <input type="checkbox"/> Addendum No. 2            | <input type="checkbox"/> Addendum No. 7  |
| <input type="checkbox"/> Addendum No. 3            | <input type="checkbox"/> Addendum No. 8  |
| <input type="checkbox"/> Addendum No. 4            | <input type="checkbox"/> Addendum No. 9  |
| <input type="checkbox"/> Addendum No. 5            | <input type="checkbox"/> Addendum No. 10 |

I understand that failure to confirm the receipt of addenda may be cause for rejection of this bid. I further understand that any verbal representation made or assumed to be made during any oral discussion held between Vendor's representatives and any state personnel is not binding. Only the information issued in writing and added to the specifications by an official addendum is binding.

Graybar Electric Co  
Company

George M. [Signature]  
Authorized Signature

9/22/15  
Date

**NOTE:** This addendum acknowledgement should be submitted with the bid to expedite document processing.  
Revised 6/8/2012



# Save energy and easily upgrade post tops to LED

## REFRACTIVE GLOBE RL34/54 WITH LUMILOCK LED ENGINE GX3 LED POST TOP LUMINAIRE

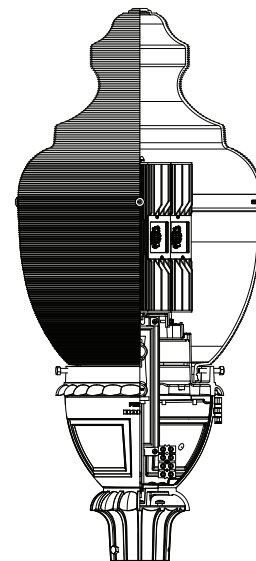

### PHILIPS HADCO, RL34/RL54 POST TOP LUMINAIRE WITH LUMILOCK GX3

Retrofitting Refractive Globe Wide Body post top luminaires with the LumiLock LED Engine GX3 will help you to beautify and add a sense of well-being and security to your outdoor space while at the same time offering energy savings and sustainability. Philips Hadco's LumiLock LED Engine GX3 is an ideal alternative to HID sources and will provide significant energy savings. It provides a quick and simple retrofit solution while maintaining excellent light levels. Refractive Globe luminaires with LumiLock LED GX3 offers two optical distributions and a range of style choices to suit any application.

Project: \_\_\_\_\_  
 Location: \_\_\_\_\_  
 Catalog No: \_\_\_\_\_  
 Fixture Type: \_\_\_\_\_  
 Mfg: \_\_\_\_\_ Qty: \_\_\_\_\_  
 Notes: \_\_\_\_\_

### Ordering guide

example: RL34 A A B A 1 A E N 32 A DA

Series	Fitter/Pod	Roof	Cage/Band	Finial	Fasteners	Finish	Photo Control	Color Temp.	LED	Voltage	Dimming Control
<input type="checkbox"/>	<input type="checkbox"/>	<input type="checkbox"/>	<input type="checkbox"/>	<input type="checkbox"/>	<input type="checkbox"/>	<input type="checkbox"/>	<input type="checkbox"/>	<input type="checkbox"/>	<input type="checkbox"/>	<input type="checkbox"/>	<input type="checkbox"/>
<b>RL34</b> LumiLock LED GX3 Type III Distribution	<b>A</b> Octagonal Style <b>B</b> Round Fitter with Scalloped Petals <b>H</b> Round Contemporary <b>L</b> Round Fluted Long <b>T</b> Decorative Leaf w/ scalloped petals	<b>A</b> Victorian <b>B</b> Acorn <b>C</b> Tall <b>D</b> Short <b>G</b> Adams	<b>B'</b> Cage for Wide Body Globe <b>E</b> Band for Wide Body Globe <b>F</b> Band for Wide Body Globe <b>G'</b> Cage for Wide Body Globe <b>I'</b> Cage for Wide Body Globe <b>J'</b> Cage for Wide Body Globe	<b>A</b> A Finial <b>B</b> B Finial <b>C<sup>2</sup></b> C Finial <b>D<sup>2</sup></b> D Finial <b>E<sup>2</sup></b> E Finial <b>F</b> F Finial <b>G</b> G Finial <b>H</b> H Finial <b>N</b> None	<b>1</b> Hex Head <b>2</b> Allen Head	<b>A</b> Black <b>B</b> White <b>G</b> Verde <b>H</b> Bronze <b>J</b> Green	<b>E</b> 120 VAC Button Eye <b>H</b> 208/240/277 VAC Button Eye <b>K</b> 347V Button Eye <b>R</b> Twist-lock Receptacle <b>N</b> None	<b>W</b> 3000K <b>N</b> 4000K <b>C</b> 5000K	<b>32<sup>3</sup></b> 32 LEDs <b>64</b> 64 LEDs	<b>A</b> 120-277 VAC <b>B<sup>3,4</sup></b> 347-480 VAC	<b>DA</b> 4 Hrs, 25% reduction <b>DB</b> 4 Hrs, 50% reduction <b>DC</b> 4 Hrs, 75% reduction <b>DD</b> 6 Hrs, 25% reduction <b>DE</b> 6 Hrs, 50% reduction <b>DF</b> 6 Hrs, 75% reduction <b>DG</b> 8 Hrs, 25% reduction <b>DH</b> 8 Hrs, 50% reduction <b>DJ</b> 8 Hrs, 75% reduction <b>DZ</b> Custom Dimming Schedule <b>N</b> None

1. Not available with (A) pod.  
 2. Not available with (B) roof.  
 3. 347- 480V not available with 32 LEDs.  
 4. Not available with Dimming.



# REFRACTIVE GLOBE RL34/54 WITH LUMILOCK LED ENGINE GX3 LED POST TOP LUMINAIRE

## Specifications

### LED Specifications

Approximately 80,000 hours of operational life (at 25 C ambient temperature & 70% lumen maintenance). Universal optics bracket design. IP66 Sealed, clear glass lens. 3000K(warm), 4000K(neutral) & 5000K(cool) color temperature (CCT). Power factor 0.99 at 120 VAC input. 3000K and 4000K have CRI of 70. 5000K has CRI of 80.

### Controls

There are 9 standard factory set dimming schedules available. See specification sheet for details. A custom dimming schedule is available by contacting the factory. Built in DynaDimmer does not allow for dimming override features.

### Housing

#### Optional Pods:

**A:** Octagonal style fitter is constructed of die-cast 360 aluminum alloy with bottom-hinged door providing 135° entry into the fitter assembly for easy access to the electrical components. Accepts standard HADCO Twistlock ballast assemblies. Wiring block to accept three #8 solid or stranded wires. Optional internal twist-lock photo eye receptacle (available for 200W MH max or 150W HPS max) or optional button eye photocell. Easy access to photo eye through the door on the pod. Heavy cast aluminum post fitter utilizes four 5/16-18 black cadmium stainless steel set screws (Hex head or Allen head as specified) for mounting to 3" O.D. post tenon. Globe holder has an internal water trap to prevent water from entering ballast compartment. Globe is held by utilizing four 5/16-18 black cadmium stainless steel fasteners (Hex head or Allen head as specified). All hardware to be stainless steel and captive. Pod height is 10-3/4" and width is 10-1/4".

**B:** Round fitter with scalloped petals is constructed of die-cast 360 aluminum alloy with side-hinged door providing 180° entry into the fitter assembly for easy access to the electrical components. Accepts standard HADCO Twistlock ballast assemblies. Wiring block to accept three #8 solid or stranded wires. Optional internal twist-lock photo eye receptacle (available for 200W MH max or 150W HPS max) or optional button eye photocell. Easy access to photo eye through the door on the pod. Heavy cast aluminum post fitter utilizes four 5/16-18 black cadmium stainless steel set screws (Hex head or Allen head as specified) for mounting to 3" O.D. post tenon. Globe holder has an internal water trap to prevent water from entering ballast compartment. Globe is held by utilizing four 5/16-18 black cadmium stainless steel fasteners (Hex head or Allen head as specified). All hardware to be stainless steel and captive. Pod height is 12-1/4" and width is 11-1/2".

**H:** Round contemporary fitter is constructed of 356 HM High-Strength, Low-Copper cast aluminum. Accepts standard HADCO Twistlock ballast assemblies. Wiring block to accept three #8 solid or stranded wires. Optional internal twist-lock photo eye receptacle (available for 200W MH max or 150W HPS max) or optional internal button eye photocell. Easy access to photocell through tool-

less door on pod. Heavy cast aluminum post fitter utilizes four 5/16-18 black cadmium stainless steel set screws (Hex head or Allen head as specified) for mounting to 3" O.D. post tenon. Globe holder has an internal water trap to prevent water from entering ballast compartment. Globe is held by utilizing four 5/16-18 black cadmium stainless steel fasteners (Hex head or Allen head as specified). All hardware to be stainless steel and captive. Pod height is 10" and width is 10".

**L:** Round fluted long fitter is constructed of 356 HM High-Strength, Low-Copper cast aluminum with a side-hinged door providing entry into the fitter assembly for easy access to the electrical components. Accepts standard Hadco Twistlock ballast assemblies. Wiring block to accept three #8 solid or stranded wires. Optional internal twist-lock photo eye receptacle or button eye photocell. Tool-less access to photo eye through the door on the pod. Heavy cast aluminum post fitter utilizes three 5/16-18 black cadmium stainless steel set screws (Hex head or Allen head as specified) for mounting to 3" O.D. post tenon. Globe holder has an internal water trap to prevent water from entering the ballast compartment. Globe is attached using four 5/16-18 black cadmium stainless steel fasteners (Hex head or Allen head as specified). Pod height is 12-1/2" and width is 10-3/4".

**T:** Decorative Leaf fitter with scalloped petals is constructed of 356 HM High-Strength, Low-Copper cast aluminum with side-hinged door providing 180° entry into the fitter assembly for easy access to the electrical components. Accepts standard HADCO Twistlock ballast assemblies. Wiring block to accept three #8 solid or stranded wires. Optional internal twist-lock photo eye receptacle (available for 200W MH max or 150W HPS max) or optional button eye photocell. Easy access to photo eye through the door on the pod. Heavy cast aluminum post fitter utilizes four 5/16-18 black cadmium stainless steel set screws (Hex head or Allen head as specified) for mounting to 3" O.D. post tenon. Globe holder has an internal water trap to prevent water from entering ballast compartment. Globe is held by utilizing four 5/16-18 black cadmium stainless steel fasteners (Hex head or Allen head as specified). All hardware to be stainless steel and captive. Pod height is 15-1/4" and width is 11-1/2".

#### Roof

**A:** Victorian style roof is clear injection molded U.V. stabilized acrylic with 99 horizontal prisms for a soft, even glow. 13" height and 16-1/2" width. The roof and bottom globe sections are secured in a slip-fit, 1/2" overlap design and use four #10-24 stainless steel pan head screws with four aluminum nutserts providing a mechanical lock and enabling easy future replacement of either the roof or bottom globe section if required.

**B:** Acorn style roof is clear injection molded U.V. stabilized acrylic with 74 horizontal prisms for a soft, even glow. 9-1/2" height and 16-3/4" width. The roof and bottom globe sections are secured in a slip-fit, 1/2" overlap design and use four #10-24 stainless steel pan head screws with four aluminum nutserts providing a mechanical lock and enabling easy future replacement of either the roof or bottom globe section if required.

**C:** Roof is 0.060" thick spun aluminum. 12" height and 17" width. The roof and bottom globe sections are secured in a slip-fit, 1/2" overlap design and use four #10-24 stainless steel pan head screws with four aluminum nutserts providing a mechanical lock and enabling easy future replacement of either the roof or bottom globe section if required.

**D:** Roof is 0.090" thick spun aluminum. 8-1/2" height and 16-1/2" width. The roof and bottom globe sections are secured in a slip-fit, 1/2" overlap design and use four #10-24 stainless steel pan head screws with four aluminum nutserts providing a mechanical lock and enabling easy future replacement of either the roof or bottom globe section if required.

**G:** Roof is 0.080" thick spun aluminum. 10-1/2" height and 16-3/4" width. The roof and bottom globe sections are secured in a slip-fit, 1/2" overlap design and use four #10-24 stainless steel pan head screws with four aluminum nutserts providing a mechanical lock and enabling easy future replacement of either the roof or bottom globe section if required.

#### Cages and Bands

**B:** Cage for Wide body globes (16-1/2" dia.) is constructed of die-cast 360 aluminum alloy. Cage has 4 legs each with square decorative flower block. Solid rectangular band around top of cage. Height of cage is 15" and width of cage is 20". Finish is polyester thermoset powdercoat. (NOTE: Cannot be used with "A" Pod.)

**E:** Band for Wide body globes (16-1/2" dia.) is architectural slotted aluminum. Supported at 4 points by cast aluminum square flower blocks.

**F:** Band for Wide body globes (16-1/2" dia.) is architectural slotted aluminum supported at 4 points by cast aluminum round flower blocks.

**G:** Cage for Wide body globes (16-1/2" dia.) is constructed of 356 HM High-Strength, Low-Copper cast aluminum. Arched, decorative legs are welded to form a one-piece unit. Height of cage is 13" and width of cage is 18-1/2". (NOTE: Cannot be used with "A" Pod.)

**I:** Cage for Wide body globes (16-1/2" dia.) is constructed of 356 HM High-Strength, Low-Copper cast aluminum. Cage has 2 curved legs. Solid fluted band around top of cage. Height of cage is 14-1/2" and width of cage is 19-3/4". (NOTE: Cannot be used with "A" Pod.)

**J:** Cage for Wide body globes (16-1/2" dia.) is constructed of 356 HM High-Strength, Low-Copper cast aluminum. Cage has 4 curved legs. Solid fluted band around top of cage. Height of cage is 14-1/2" and width of cage is 19-3/4". (NOTE: Cannot be used with "A" Pod.)

#### Finials

All finials are cast aluminum mounted with 1/4-20 stainless steel threaded studs. Standard finial finish will match fixture finish as specified. Finish is thermoset powdercoat. (NOTE: C, D, and E finials are not available with "B" Roof.)

#### Fasteners

Used to secure post fitter to post tenon and globe to globe holder.

- 1: Hex Head Bolts: Black cadmium stainless steel.
- 2: Allen Head Bolts: Black cadmium stainless steel.

# REFRACTIVE GLOBE RL34/54 WITH LUMILOCK LED ENGINE GX3 LED POST TOP LUMINAIRE

## Finish

Thermoset polyester powdercoat is electrostatically applied after a five-stage conversion cleaning process and bonded by heat fusion thermosetting. Laboratory tested for superior weatherability and fade resistance in accordance with ASTM B117 specifications. For larger projects where a custom color is required, contact the factory for more information.

## Optical Assembly

### GLOBE AND OPTICAL ASSEMBLY:

Wide body globe is constructed of clear injection-molded U.V. stabilized acrylic. A two-piece (Globe and Roof) slip-fit, 1/2" overlap, design utilizes nutserts and stainless steel fasteners, which eliminates a "butt-glue" seam appearance. The optical section of the globe has a neck opening of 7-3/8" and an outside neck diameter of 8". Globe (less the roof) has a 12-7/8" height and 16-3/4" width at the top with 98 horizontal prisms and 360 highly polished vertical prisms.

## Electronic Driver

The driver included is the Philips Advance XITANIUM LED driver and is available in 350mA (64 LED) and 530 mA (32 LED) drive currents. Universal voltage input from 120-277VAC or 347-480VAC. Input frequency is 50-60Hz and all XITANIUM drivers are RoHS compliant. A separate 10kV/10kA surge suppression module is automatically included. Programmable dimming 0-10V is optional (see controls specifications).

## Vibration Resistance

Vibration tested to ANSI C136.31 for Bridge Applications.

## Certifications

Manufactured to ISO 9001:2008 Standards. ETL listed to U.S. safety standards for wet locations. cETL listed to Canadian safety standards for wet locations. RL34 and RL54 luminaires with 4000K color temperature are qualified by DesignLights Consortium.

## Limited Warranty

5 year extended limited warranty.

## Max EPA

2.08 sq. Ft. (Varies depending on options selected)

## Max Weight

59 Lbs

## IESNA Classifications:

See .ies files. Deprecated: Refer to BUG Ratings.

## RL34 Dimensions\*

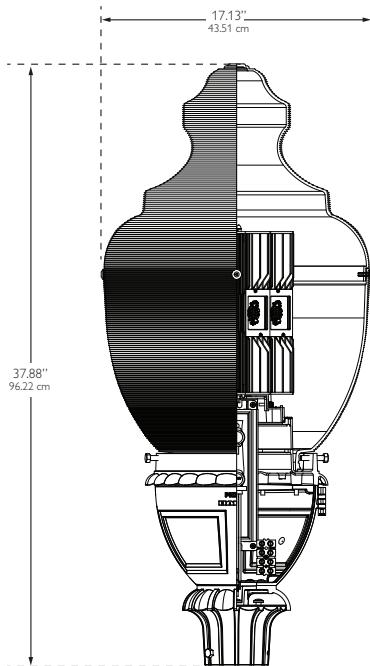

\*RL34 B A N N configuration shown  
Dimensions will vary when other pod, roof, and finial options are specified.

## RL54 Dimensions\*

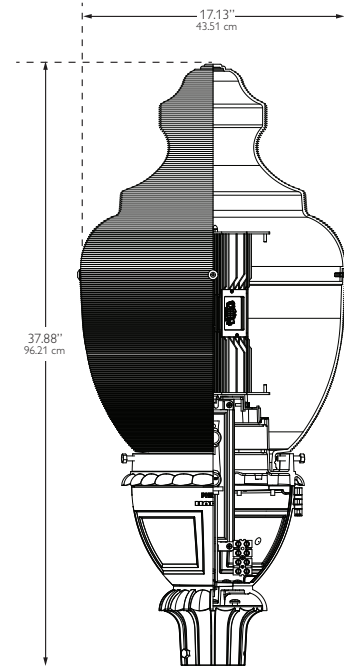

\*RL54 B A N N configuration shown.  
Dimensions will vary when other pod, roof, and finial options are specified.

# REFRACTIVE GLOBE RL34/54 WITH LUMILOCK LED ENGINE GX3 LED POST TOP LUMINAIRE

## RL34 - GX3 Performance Data

IES File Name	Color Temp.	Delivered Lumens	Wattage	Efficacy	BUG Rating
RL34-3V3KL325CN-14	3000K	4,952	51	97	B1-U5-G2
RL34-3V3KL325SN-14	3000K	3,308	52	64	B1-U3-G2
RL34-3V3KL643CN-14	3000K	6,772	68	99	B2-U5-G3
RL34-3V3KL643SN-14	3000K	4,562	69	66	B2-U3-G2
RL34-3V4KL325CN-14	4000K	5,234	51	102	B1-U5-G2
RL34-3V4KL325SN-14	4000K	3,461	51	68	B1-U3-G2
RL34-3V4KL643CN-14	4000K	7,159	68	105	B2-U5-G3
RL34-3V4KL643SN-14	4000K	4,991	68	73	B2-U3-G2
RL34-3V5KL325CN-14	5000K	4,276	51	83	B1-U5-G2
RL34-3V5KL325SN-14	5000K	2,828	51	55	B1-U3-G2
RL34-3V5KL643CN-14	5000K	5,849	68	86	B2-U5-G3
RL34-3V5KL643SN-14	5000K	4,077	68	60	B1-U3-G2

## RL54 - GX3 Performance Data

IES File Name	Color Temp.	Delivered Lumens	Wattage	Efficacy	BUG Rating
RL54-5V3KL325CN-14	3000K	4,943	51	97	B3-U5-G2
RL54-5V3KL325SN-14	3000K	3,304	52	64	B3-U3-G1
RL54-5V3KL643CN-14	3000K	6,771	68	100	B3-U5-G2
RL54-5V3KL643SN-14	3000K	4,641	69	68	B3-U3-G2
RL54-5V4KL325CN-14	4000K	5,225	51	102	B3-U5-G2
RL54-5V4KL325SN-14	4000K	3,474	51	68	B3-U3-G1
RL54-5V4KL643CN-14	4000K	7,157	68	105	B3-U5-G2
RL54-5V4KL643SN-14	4000K	5,017	68	74	B3-U3-G2
RL54-5V5KL325CN-14	5000K	4,269	51	84	B3-U5-G1
RL54-5V5KL325SN-14	5000K	2,801	51	55	B3-U3-G1
RL54-5V5KL643CN-14	5000K	5,848	68	86	B3-U5-G2
RL54-5V5KL643SN-14	5000K	4,099	68	60	B3-U3-G1

## RL34/RL54 - Housing Options

### Fitter/Pod Options



### Roof Options



### Cage/Band Options



1.) Not available with A pod.

### Finial Options



2.) Not available with B Roof.



© 2014 Koninklijke Philips N.V. All rights reserved.  
Specifications are subject to change without notice.  
[www.philips.com/luminaires](http://www.philips.com/luminaires)

RL34/RL54 03/14 page 4 of 4

Philips Lighting  
North America Corporation  
200 Franklin Square Drive  
Somerset, NJ 08873  
Phone: 855-486-2216

Philips Lighting Company  
281 Hillmount Road  
Markham ON, Canada L6C 2S3  
Phone: 800-668-9008