



Purchasing Division
 2019 Washington Street East
 Post Office Box 50130
 Charleston, WV 25305-0130

State of West Virginia
 Request for Quotation

Proc Folder: 35041
 Doc Description: Tandem Tractor
 Proc Type: Central Purchase Order

Date Issued	Solicitation Closes	Solicitation No	Version
2014-09-23	2014-10-23 13:30:00	CRFQ 1400 AGR1500000004	1

BID RECEIVING LOCATION
 BID CLERK
 DEPARTMENT OF ADMINISTRATION
 PURCHASING DIVISION
 2019 WASHINGTON ST E
 CHARLESTON WV 25305
 US

VENDOR
 Vendor Name, Address and Telephone Number:
 Worldwide Equipment Inc.
 Lewis County Industrial Park
 Jane Lew WV 26378 304-884-7815 or 800-879-3039

10/22/14 09:44:22AM
 West Virginia Purchasing Division

FOR INFORMATION CONTACT THE BUYER
 Dean Wingerd
 (304) 558-0468
 dean.c.wingerd@wv.gov

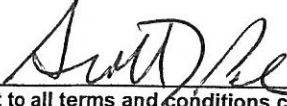
Signature X  FEIN # 45-1024981 DATE 10/21/14
 All offers subject to all terms and conditions contained in this solicitation

INVOICE TO		SHIP TO	
PROCUREMENT OFFICER 304-558-2221 AGRICULTURE DEPARTMENT OF ADMINISTRATIVE SERVICES 1900 KANAWHA BLVD E CHARLESTON WV25305-0173 US		AUTHORIZED RECEIVER 304-558-0573 AGRICULTURE DEPARTMENT OF FOOD DISTRIBUTION PROGRAM 4496 CEDAR LAKES RD RIPLEY WV 25271 US	

Line	Comm Ln Desc	Qty	Unit Issue	Unit Price	Total Price
1	Tandem Tractor	1.00000	EA	\$ 110,538	\$ 110,538

Comm Code	Manufacturer	Specification	Model #
25102100	<i>Kenworth</i>	<i>✓</i>	<i>T800</i>

Extended Description :

**THE WEST VIRGINIA PURCHASING DIVISION FOR THE AGENCY, DEPARTMENT OF AGRICULTURE, IS SOLICITING BIDS FOR THE ONE-TIME PURCHASE OF A MODEL YEAR 2015 CLASS 8 DAY CAB TANDEM TRACTOR, FOR THE FOOD DISTRIBUTION PROGRAM, PER THE ATTACHED SPECIFICATIONS.

*** LINE NUMBER 1- 2015 Class 8 Day Cab Tandem Tractor for Donated Foods

INVOICE TO		SHIP TO	
PROCUREMENT OFFICER 304-558-2221 AGRICULTURE DEPARTMENT OF ADMINISTRATIVE SERVICES 1900 KANAWHA BLVD E CHARLESTON WV25305-0173 US		AUTHORIZED RECEIVER 304-558-0573 AGRICULTURE DEPARTMENT OF FOOD DISTRIBUTION PROGRAM 4496 CEDAR LAKES RD RIPLEY WV 25271 US	

Line	Comm Ln Desc	Qty	Unit Issue	Unit Price	Total Price
2	Additional Fees	1.00000	EA		

Comm Code	Manufacturer	Specification	Model #
25102100	<i>Kenworth</i>	<i>✓</i>	<i>T800</i>

Extended Description :

Additional Fees (if necessary)

CERTIFICATION AND SIGNATURE PAGE

By signing below, or submitting documentation through wvOASIS, I certify that I have reviewed this Solicitation in its entirety; understand the requirements, terms and conditions, and other information contained herein; that I am submitting this bid, offer or proposal for review and consideration; that I am authorized by the vendor to execute and submit this bid, offer, or proposal, or any documents related thereto on vendor's behalf; that I am authorized to bind the vendor in a contractual relationship; and that to the best of my knowledge, the vendor has properly registered with any State agency that may require registration.

Worldwide Equipment Inc
(Company)

Scott Peter Scott Peter Director of Government & Municipal Sales
(Authorized Signature) (Representative Name, Title)

800-879-3039 / 859-253-4639 10/21/14
(Phone Number) (Fax Number) (Date)

SPECIFICATIONS

- ✓ 1. **PURPOSE AND SCOPE:** The West Virginia Purchasing Division is soliciting bids on behalf of WV Department of Agriculture to establish a contract for the one time purchase of a 2015 or newer Class 8 Day Cab Tandem Tractor.
 - ✓ 2. **DEFINITIONS:** The terms listed below shall have the meanings assigned to them below. Additional definitions can be found in section 2 of the General Terms and Conditions.
-

- 2.1 "Contract Item" means 2015 or newer Class 8 Day Cab Tandem Tractor. *2016 Kenworth T800*
- ✓ 2.2 "Pricing Page" means the pages upon which Vendor should list its proposed price for the Contract Items in the manner requested. The Pricing Page is either included on the last page of this RFQ or attached hereto as Exhibit A. Vendors may also submit bids using the VSS/WV Oasis website and insert pricing on the commodity lines.
- ✓ 2.3 "RFQ" means the official request for quotation published by the Purchasing Division.

3. GENERAL REQUIREMENTS:

- ✓ 3.1 **Mandatory Contract Item Requirements:** Contract Item must meet or exceed the mandatory requirements listed below.
 - ✓ 3.1.1 **2015 or newer class 8 Day Cab Tandem Tractor** *2016 Kenworth T800*
 - ✓ 3.1.1.1 Wheelbase must accommodate a 48 foot reefer trailer.
 - ✓ 3.1.1.2 Engine must be compatible with Cummins ISx15 or Detroit DD15 or equal, minimum HP 450 to maximum HP 500, Jacobs engine brake or equivalent. **No Exhaust Engine Brake**, Engine Block heater 1500 watts-min, exhaust single vertical stainless steel from motor with guard.
 - ✓ 3.1.1.3 Transmission must be 13 speeds or equivalent.
 - ✓ 3.1.1.4 Cab Interior and Exterior must have Air conditioner with heat and filter.

-
- ✓ 3.1.1.5 Full gauge package, Power windows both sides, Mirrors—remote controlled with built in convex and heated, minimum 10 inch convex mounted on LH & RH front fender or hood.
 - ✓ 3.1.1.6 Radio—AM-FM-CD and blue tooth, prewired for CB Radio including dual mounted antenna's on mirrors.

 - ✓ 3.1.1.7 Driver seat Bostrom high profile (910 or BAJH) or equal, no air seat on passenger side.
 - ✓ 3.1.1.8 Sun visor—Interior both sides padded.
 - ✓ 3.1.1.9 Power steering, Tilt & telescopic steering & smallest steering wheel available for unit with Cruise control.
 - ✓ 3.1.1.10 Anti-sail mud flaps with stainless mounts.
 - ✓ 3.1.1.11 Roof mounted air deflector not to exceed 12.5' total truck height.
 - ✓ 3.1.1.12 Cat walk mounted behind cab, all pigtails spring mounted on back of cab with glad hand mount, 12volt pigtail to charge lift gate on trailer.
 - ✓ 3.1.1.13 Stainless front bumper.
 - ✓ 3.1.1.14 Fuel Tanks must be Minimum 100 gallon LH & 100 gallon RH aluminum. With stainless mounts and straps.
 - ✓ 3.1.1.15 Front Axle must be Minimum 12,000 pound capacity. Step back for tight turning springs: Flat leaf or taper leaf.
 - ✓ 3.1.1.16 Rear Axle must be Minimum 40,000 pound capacity Tandem with driver controlled differential lock suspension: air ride with inside cab mount dump valve. Geared to maintain 70 MPH at 300-RPM below governor on engine.

-
- ✓ 3.1.1.17 Tires & Wheels must be 11R22.5 Steer & 11R22.5 all season on rear (no low profile) 16 ply.
 - ✓ 3.1.1.18 Wheels: Alloy.
 - ✓ 3.1.1.19 Brakes must be "S" cam brakes with auto adjusters, Air dryer: Bendix "system guard" AD-9 or equal.
-
- ✓ 3.1.1.20 Electrical must be Aluminum. Battery box & covers—12volt system.
 - ✓ 3.1.1.21 Fifth Wheel must be Fontain no-slack II, C7000 series with air slide 24 inch travel or equal.
 - ✓ 3.1.1.22 Warranty must be 3 year bumper to bumper.

4. CONTRACT AWARD:

- ✓ 4.1 **Contract Award:** The Contract is intended to provide Agencies with a purchase price for the Contract Items. The Contract shall be awarded to the Vendor that provides the Contract Items meeting the required specifications for the lowest overall total cost as shown on the Pricing Pages or on the commodity lines if bid electronically via the VSS system.
- ✓ 4.2 **Pricing Page:** Vendor should complete the Pricing Page by listing the equipment make, model and cost along with any additional equipment fees. Vendor should complete the Pricing Page, or commodity lines in full as failure to complete in its entirety may result in Vendor's bid being disqualified.

Notwithstanding the foregoing, the Purchasing Division may correct errors as it deems appropriate.

5. PAYMENT:

- ✓ 5.1 **Payment:** Vendor shall accept payment in accordance with the payment procedures of the State of West Virginia.

6. DELIVERY AND RETURN:

✓ **6.1 Shipment and Delivery:** Vendor shall ship the Contract Items immediately after being awarded this Contract and receiving a purchase order. Vendor shall deliver the Contract Items within 180 Days working days after receiving the purchase order. Contract Items must be delivered to Agency at 4496 Cedar Lakes Road, Ripley, WV 25271.

✓ **6.2 Late Delivery:** The Agency placing the order under this Contract must be notified in writing if the shipment of the Contract Items will be delayed for any reason. Any delay in delivery that could cause harm to an Agency will be grounds for cancellation of the Contract, and/or obtaining the Contract Items from a third party.

Any Agency seeking to obtain the Contract Items from a third party under this provision must first obtain approval of the Purchasing Division.

✓ **6.3 Delivery Payment/Risk of Loss:** Vendor shall deliver the Contract Items F.O.B. destination to the Agency's location.

✓ **6.4 Return of Unacceptable Items:** If the Agency deems the Contract Items to be unacceptable, the Contract Items shall be returned to Vendor at Vendor's expense and with no restocking charge. Vendor shall either make arrangements for the return within five (5) days of being notified that items are unacceptable, or permit the Agency to arrange for the return and reimburse Agency for delivery expenses. If the original packaging cannot be utilized for the return, Vendor will supply the Agency with appropriate return packaging upon request. All returns of unacceptable items shall be F.O.B. the Agency's location. The returned product shall either be replaced, or the Agency shall receive a full credit or refund for the purchase price, at the Agency's discretion.

✓ **6.5 Return Due to Agency Error:** Items ordered in error by the Agency will be returned for credit within 30 days of receipt, F.O.B. Vendor's location. Vendor shall not charge a restocking fee if returned products are in a resalable condition. Items shall be deemed to be in a resalable condition if they are unused and in the original packaging. Any restocking fee for items not in a resalable condition shall be the lower of the Vendor's customary restocking fee or 5% of the total invoiced value of the returned items.

EXHIBIT A

PRICING PAGE

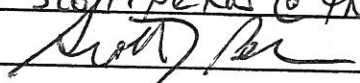
Item No.	Description	Model No/Brand Name	Quantity	Unit Price	Extended Amount
1	2015 Class 8 Day Cab Tandem Tractor 2016	T800/Kenworth	1	\$110,538	\$110,538
2	Additional Fees:				—
	Failure to use this form may result in disqualification				
	Bidder / Vendor Information			GRAND TOTAL	\$110,538
Name:	Worldwide Equipment Inc				
Address:	Lewis County Industrial Park				
	Jane Lew WV 26378				
Phone:	304-884-7815 Jane Lew				
Email Address:	Scott S. Petar, Director of Government & Municipal Sales				
Authorized Signature:	800-879-3039 / cell 859-333-8602				
	Scott.Petar@theTruckPeople.com				
					



Worldwide Equipment W008
945 Nandino Blvd

State of West Virginia
2019 Washington street East

Lexington, Kentucky United States 40514
Phone: (800) 237-1878
Fax:
Email: scott.pekar@thetruckpeople.com

Charleston, West Virginia United States 25305
Phone: (304) 558-0468
Fax:
Contact Email:
Prepared for: Dean Wingerd

Customer Quote

Equipment

Quantity Ordered:	1
Truck Price:	\$163,451
Dealer Options:	\$0
Equipment List Price:	\$163,451
Surcharges Not Subject to Discount:	\$9,250
Options Not Subject to Discount:	\$4,875
Factory Freight Cost:	\$2,125

Total Equipment Price: \$179,701

NET Sale Price: \$110,538

Miscellaneous

FET Tire Credit:	\$0
Net Chassis FET:	\$0
State Tax:	\$0
Body/Trailer/Accessories FET:	\$0
Fees:	\$0
Other:	\$0

Quotation Total: \$110,538

Unpublished options may require review/approval.
Dimensional and performance data for unpublished options may vary from that displayed in PROSPECTOR.

Printed:	10/21/2014 11:08:19 AM	Complete	Model Number:	T800 Series Conventional.
Effective Date:	Aug 1, 2014		Quote/DTPO/CO:	Q15600201
Prepared by:	Scott Pekar		Version Number:	34.00



Worldwide Equipment W008
945 Nandino Blvd

State of West Virginia
2019 Washington street East

Lexington, Kentucky United States 40514
Phone: (800) 237-1878
Fax:
Email: scott.pekar@thetruckpeople.com

Charleston, West Virginia United States 25305
Phone: (304) 558-0468
Fax:
Contact Email:
Prepared for: Dean Wingerd

Vehicle Summary

	Unit		Chassis	
Model:	T800 Series Conventional.	Fr Axle Load (lbs):		12000
Type:	TRACTOR	Rr Axle Load (lbs)		40000
Description:	reefer trailer	G.C.W. (lbs):		80000
	Application	Road Conditions:		
Intended Serv.:	Local pickup & delivery.	Class A (Highway)		90
	Vehicles which haul	Class B (Hwy/Mtn)		10
Commodity:	Other food/farm products	Class C (Off-Hwy)		00
	Body	Class D (Off-Road)		00
Type:		Maximum Grade:		6
Length (ft):	0.0	Wheelbase (in):		209
Height (ft):	0.0	Fr Axle to BOC (in):		74
Max Laden Weight (lbs):	0	Cab to Axle (in):		135
	Trailer	Cab to EOF (in):		195
No. of Trailer Axles:	2			
Type:	Reefer van			
Length (ft):	48.0			
Height (ft):	13.0			
Kingpin Inset (in):	36			
Corner Radius (in):	0			
	Restrictions			
Length (ft):	120			
Width (in):	102			
Height (ft):	13.5			

Special Req.
U.S. Domestic Registry, 50-State

Approved by: _____

Date: _____

Note: All sales are F.O.B. designated plant of manufacture.

	Ask your dealer for a quote today, or visit our website @ www.paccarfinancial.com .
	PACCAR Financial offers innovative finance, lease and insurance programs customized to meet your needs.

Unpublished options may require review/approval.
Dimensional and performance data for unpublished options may vary from that displayed in PROSPECTOR.

Printed:	10/21/2014 11:09:54 AM	Complete	Model Number:	T800 Series Conventional.
Effective Date:	Aug 1, 2014		Quote/DTPO/CO:	Q15600201
Prepared by:	Scott Pekar		Version Number:	34.00



Worldwide Equipment W008
945 Nandino Blvd

State of West Virginia
2019 Washington street East

Lexington, Kentucky United States 40514
Phone: (800) 237-1878
Fax:
Email: scott.pekar@thetruckpeople.com

Charleston, West Virginia United States 25305
Phone: (304) 558-0468
Fax:
Contact Email:
Prepared for: Dean Wingerd

Model	Description	Weight
	T800 Series Conventional. Elastomer bushed front spring pins & heavy-duty shock absorber brackets, 16mm. fasteners from rear cab support to end-of-frame, except tractor taper crossmember. Vinyl inside sunvisors, driver side includes strap & mirror, rider side includes strap; Under-dash center console w/ 2 cup holders, 2-12V outlets & a storage compartment, Glove box door with locking latch.	15,375
	T800: Sloped Hood.	0
	Dealer/Customer declines engine w/CARB Idle Emissions Reduction Feature.	0
	Non-Sleeper w/rear axle capacity less than 59K.	0
	Other food/farm products	0
	Local pickup & delivery. Vehicles which haul freight, typically operating within a 100-mile radius, on public streets & highways, & other paved surfaces, including limited Class C roads. Includes package & freight delivery, as well as fuel oil or petroleum distribution, etc. Road usage: minimum 3% Class B, do not code for Class D.	0
	Reefer van	0
	U.S. Domestic Registry, 50-State	0

Engine & Equipment

ISX15 450 2013 450@1800 1550@1000	275
w/Intebrake, Diagnostic Plug for data link, Oil Cooler, Aluminum Flywheel Housing. Linehaul Family 1	
N09200 N205 120..Standard Maximum Speed Limit [LSL]	
N09220 N207 0...Expiration Distance	
N09240 P13 120..Hard Maximum Speed Limit	
N09260 P14 70...Maximum Accelerator Pedal Vehicle Speed	
N09280 P16 0...Accelerator Lower Droop	
N09300 P19 70...Maximum Cruise Speed	
N09320 P38 0...Cruise Control Lower Droop	
N09360 N203 252..Reserve Speed Function Reset Distance	
N09380 N202 0...Maximum Cycle Distance	
N09400 N206 10...Maximum Active Distance	
N09420 N201 0...Reserve Speed Limit Offset	
N09440 P11 No...Engine Protection Shutdown	
N09460 P06 Yes..Gear Down Protection	
N09480 P26 1400.Max PTO Speed	

Unpublished options may require review/approval.

Dimensional and performance data for unpublished options may vary from that displayed in PROSPECTOR.

Printed:	10/21/2014 11:09:54 AM	Complete	Model Number:	T800 Series Conventional.
Effective Date:	Aug 1, 2014		Quote/DTPO/CO:	Q15600201
Prepared by:	Scott Pekar		Version Number:	34.00

Description	Weight
N09500 P02 No...Cruise Control Auto Resume	
N09520 P04 No...Auto Engine Brake in Cruise	
N09540 N209 0....Expiration Distance	
N09560 P520 Yes..Enable Idle Shutdown Park Brake Set	
N09580 P32 5....Timer Setting	
N09600 P233 Yes..Enable Impending Shutdown Warning	
N09620 P234 60...Timer For Impending Shutdown Warning	
N09640 P516 35...Engine Load Threshold	
N09680 P33 No...Idle Shutdown Manual Overrule	
N09720 P230 Yes..Enable Hot Ambient Automatic Overrule	
N09740 P46 40...Low Ambient Temperature Threshold	
N09760 P56 60...Intermediate Ambient Temperature Threshold	
N09780 P47 80...High Ambient Temperature Threshold	
Prospector version 34.0 Supersedes previous version 33.0	0
Effective VSL Setting 65.0 MPH (USA)	0
Engine Idle Shutdown Timer Disabled	0
Enable EIST Ambient Temp Overrule	0
Enable EIST in PTO Mode Use only with MX and Cummins engines	0
Eff EIST NA Expiration Miles Use only with MX and Cummins engines	0
Air compressor: Cummins 18.7 CFM, Cummins, PACCAR PX engines.	0
Air cleaner: Powercore engine mount 10 in. w/constant torque SS clamps, pop-up air restriction indicator. Holds 10% more fine dust than 2500. Pop-up indicator is standard.	0
Fan Hub: Horton 2-Speed for ISX15	0
Cooling module: T8SH/T8B/W9S 1440 square inches. On-off fan hub, nylon fan blade, translucent top tank, air-to-air heat exchanger/aftercooler, silicone hoses w/constant torque clamps, long life coolant. Drain valve is not available w/Allison transmissions.	0
Radiator bug screen mounted between hood & grille.	2
RH under cab DPF/SCR w/ RH SOC vertical tailpipe. For use w/ daycabs, extended daycabs, or modular sleepers. T660 requires split fender hood	0
Tailpipe: 5 in. single 36 in. 45 degree curved. For use with any Exhaust other than SCR Independent.	0
PACCAR Fuel filter/water separator: 12V preheat, WIF sensor Cummins ISX12/ISX15. 2013+	2
Immersion block heater 120V 1500W w/plug under door on T700, C500, T660, T800 & W900.	2
Alternator: PACCAR 160 amp, brush type	0
Batteries: 3 PACCAR GP31 threaded post (700) 2100 CCA dual purpose.	0

Unpublished options may require review/approval.
Dimensional and performance data for unpublished options may vary from that displayed in PROSPECTOR.

Printed:	10/21/2014 11:09:54 AM	Complete	Model Number:	T800 Series Conventional.
Effective Date:	Aug 1, 2014		Quote/DTPO/CO:	Q15600201
Prepared by:	Scott Pekar		Version Number:	34.00

Description	Weight
Starter: PACCAR 12 volt electrical system. W/ centralized power distribution incorporating plug-in style relays. Circuit protection for serviceability, 12-volt light system w/circuit protection circuits number & color coded.	0
Multi-function engine connector for body builder interface for Cummins. T680/T880: This feature is standard, no code required.	0
Transmission & Clutch	
Transmission: Fuller RTLO16913A 13-speed w/oil cooler & pump. Standard with synthetic lubricant. Includes severe-duty pilot bearing on all class 8 models.	113
Clutch: Eaton 4 paddle ceramic 1650 lb-ft Eaton 15-1/2 in. Easy Pedal Advantage Manual Adjust Clutch cover. Torque limiting clutch brake. Severe duty pilot bearing. Synthetic lubrication for Eaton Fuller & axles. Extended grease fitting.	0
Driveline: 2 heavy-duty 1 centerbearing.	99
Chassis will not be fitted w/transmission PTO. (PREVENTS ECU F/INTERFERING W/PTO ONLY)	0
14 in. Eaton Fuller high capacity oil to water cooler standard for transmission 1550-2250 lb-ft, 18-speed AutoShift.	0
Severe Service rear transmission support spring(s).	15
Front Axle & Equipment	
Dana Spicer E-1202I Front Axle rated 12K 3-1/2in. drop.	0
Front Brakes,Meritor Q+ RSD-Compliant S-Cam 16.5x 5 in. drum brake, Max GAWR 14.6k.	-50
Front Brake Drum: 14,600 lbs. 16-1/2x5 in. cast.	88
Front Hub: aluminum hub pilot 13,200 lbs. 10-Bolt, 11-1/4 in. bolt circle .	0
ConMet PreSet Plus Hub package; front axle.	0
Hubcap: front vented.	0
Front Auto Slack Adjuster.	0
Front Springs: Taperleaf 12K w/ shock absorbers w/ maintenance-free elastomer spring pin bushings. Standard with rubber pins except for C500 which has threaded pins. Not available on W900L.	0
Single power steering gear: 13.2K Sheppard M100P.	0
Rear Axle & Equipment	
Dual Dana Spicer DSP40 rear axle rated at 40K. w/ 9.5mm housing and 1.88in. shaft diameter. Tandem rear axles.	0
Rear Axle Ratio - 3.70.	0

Unpublished options may require review/approval.
 Dimensional and performance data for unpublished options may vary from that displayed in PROSPECTOR.

Printed:	10/21/2014 11:09:54 AM	Complete	Model Number:	T800 Series Conventional.
Effective Date:	Aug 1, 2014		Quote/DTPO/CO:	Q15600201
Prepared by:	Scott Pekar		Version Number:	34.00

Description	Weight
Rear Brakes, Meritor Q+ RSD-Compliant S-Cam 16.5x7 in.tandem axle drum brake, Max GAWR 50k.	17
Dual Rear Brake Drums: cast.	0
Dual Rear Hubs: Aluminum hub pilot 46K 11-1/4 in. bolt circle.	0
ConMet PreSet Plus Hub package; dual rear axle.	0
Dual Rear axle automatic slack adjusters.	0
Spring Brake: 3030 long stroke dual 30 square inches travel; replaces standard 2-1/2 in. travel. Helps keep brakes in adjustment longer.	0
Bendix 4S/4M anti-lock brake system. Current generation ECU is Bendix ABS 6.	0
Rear suspension: Tandem Kenworth Airglide 400L 40K. 54 in. axle spacing. Air suspension w/ 8.5 in. ride height. Includes single leveling valve. Includes air suspension dump valve.	-224

Tires & Wheels

Front tires: Bridgestone R250ED 11R22.5 16PR. 41.4 in. diameter, all position. Side wall protector bar. 19.3 in. SLR.	3
Rear tires: Bridgestone M799 11R22.5 16PR. 42 in. diameter, drive. 19.5 in. SLR. Code is priced per pair of tires.	80
Rear Tire Quantity: 8	0
Front wheel: Accuride 50487 22.5x8.25 steel Steel Armor[™] powder coat, hub pilot mount. 7400lb. maximum rating. 5-hand hole. Air disc brake compatible.	0
Rear wheel: Accuride 50487 22.5x8.25 steel Steel Armor[™] powder coat, hub pilot mount. 7400lb. maximum rating. 5-hand hole. Air disc brake compatible. Code is priced per pair of wheels.	0
Rear Wheel/Rim Quantity: 8	0

Frame & Equipment

Frame Rails: 10-5/8 x 3-1/2 x 5/16 in. Steel to 285 in. to 336 in. Truck frame weight is 2.91 lb.-in. per pair of rails. Section modulus is 14.80, RBM is 1,776,000 in.-lbs per rail. Frame rail availability may be restricted based upon application, axle/suspension capacity, fifth wheel setting, or component/dimensional specifications. The results of the engineering review may result in a change to the requested frame rail. If a change is required Kenworth Application Engineering will advise the dealer of the appropriate material specification for a substitute rail.	139
Bumper: Straight Aluminum Channel. Requires a bumper setting code.	0
48.5 in. Bumper setting. Requires a bumper code.	0
Removable Front Tow Hooks: 2.	15
Front mudflaps.	0

Unpublished options may require review/approval.
Dimensional and performance data for unpublished options may vary from that displayed in PROSPECTOR.

Printed:	10/21/2014 11:09:54 AM	Complete	Model Number:	T800 Series Conventional.
Effective Date:	Aug 1, 2014		Quote/DTPO/CO:	Q15600201
Prepared by:	Scott Pekar		Version Number:	34.00

Description	Weight
Battery box module: Short length aluminum parallel under cab, aluminum diamond plate cover w/ step. Up to 2 air tanks may mount to bottom of box. Batteries will be oriented perpendicular on rail.	0
Battery box location: LH Side.	0
T470,C500,T660,T800 non-polished DPF/SCR cover: diamond plate w/step for use w/2010 style exhaust. For T800- use extended length non-polished battery box on opposite rail to match the length of under cab components.	30
Fifth Wheel: Fixed, Holland FW35Y800XL00 8.00 in. height. Outboard mounting angles, 55K vertical rating, LH release. The code for additional factory drilled settings is available. Accommodates a 2 in. SAE kingpin. Requires some style of trailer connections.	401
FW rear/fixing setting ahd of bogie 0 in indicates rearmost setting measured forward from centerline of tandem or single rear axle	0
Rear mudflap arms: Betts B-25 standard-duty, straight. Includes B1732 mounting brackets as standard.	0
Rear mudflap shields: White plastic antisail w/ Kenworth logo.	0
Quarter Fenders: Black Polypropylene w/ painted steel brackets, single post mounted.	43
Tractor Taper w/ heavy-duty crossmember. Non-towing end-of-frame configuration.	61

Fuel Tanks & Equip

Fuel Tank: 100 US gallon 24.5in. aluminum BOC replace. Class 8 fuel tanks w/ o locking caps include an anti-siphon device on the filler neck.	0
Fuel Tank: 100 US gallon 24.5in. aluminum BOC add. Class 8 fuel tanks w/ o locking caps include an anti-siphon device on the filler neck. Multiple tank installations include a fuel equalization system w/ dual draw and return lines with a splitter valve located within 6 inches behind the cab. Single draw and return is an option in some cases.	114
Medium round DEF tank. 20.7 gallons of useable volume. The DEF tank will be located on the side you specified, but will not be displayed in the Prospector graphic. If you have specific configuration or body builder concerns, please utilize the Custom Frame Layout option. Required capacity is calculated by fuel capacity of the vehicle and will accommodate two diesel re-fillings for every DEF re-filling.	32
Anti-siphon device swaged in place. For any number of fuel tanks.	0
DEF tank location is on the LH.	0
Location: 100 gal fuel tank RH behind cab	0
Location: 100 gal fuel tank LH behind cab	0

Unpublished options may require review/approval.
Dimensional and performance data for unpublished options may vary from that displayed in PROSPECTOR.

Printed:	10/21/2014 11:09:54 AM	Complete	Model Number:	T800 Series Conventional.
Effective Date:	Aug 1, 2014		Quote/DTPO/CO:	Q15600201
Prepared by:	Scott Pekar		Version Number:	34.00

Description	Weight
Cab & Equipment	
Cab: Curved Glass Conventional. Cab Includes aluminum & fiberglass fully hucked cab w/ all aluminum bulkhead doors & continuous stainless steel piano-style door hinges. Single electric horn standard. Incandescent exterior lights include diagnosable bulb detection and warning. Trailer cable on tractors includes integrity detection. Standard features include multiplex wiring for interior lights, automated pre-trip inspection, short and open check diagnostics. Warning alarm will sound when lights are left on.	0
Hood: Sloped Metton hood w/ grille & shell use for T800B 1-piece requires engine mounted air cleaner, 1440 square in. radiator & 2007+ engines.	0
Cab heater: W/integral defrosters & A/C 45,000 btu cab heater. No sleeper heater/AC. Includes 5 mode rotary control. T660 include filter media.	0
Steering wheel: 18 in. 4-spoke.	0
Adjustable telescoping tilt steering column.	10
Two spare switches: Wired to power.	0
KW Driver Information Center: Includes fuel economy, RPM display, trip information, truck information, diagnostics, gear display, alarm clock.	0
Instrument package: Includes speedometer, tachometer, fuel gauge, engine coolant temperature gauge, engine oil pressure, voltmeter. Class 8 also includes primary & secondary air reservoir gauges & an air application gauge. DEF level gauge and warning lamp are included with 2010+ engines. Engine hour meter and outside air temperature readouts are standard. Primary read out will be MPH. Add 8240620 to switch primary scale to KPH in Canada.	0
Cab interior: Splendor. Includes smooth upholstered side & back panels w/stitched accent lines, upholstered door pads, full vinyl headliner, black dash panels & black rubber floor mats.	0
Interior color: Slate Gray w/trim Dark Slate Gray	0
Driver seat: Kenworth Air cushion Plus HB cloth. Standard features includes 7 in. fore and aft slide adjustment w/isolator, 6-23 degree recline, air suspension with cover, dual armrests, and single chamber air lumbar support. Seat cushion is 20 inches wide w/ 2-position tilt and 2-position front cushion extension. Seat material has a horizontal stitch pattern and is 2-tone in color. Seat back is carpeted and includes a map pocket. Seat is manufactured by National. Includes inside visor and retractable 3-point matching seat belts. Black seat belts for T700, gray on all other models.	0

Unpublished options may require review/approval.
Dimensional and performance data for unpublished options may vary from that displayed in PROSPECTOR.

Printed:	10/21/2014 11:09:54 AM	Complete	Model Number:	T800 Series Conventional.
Effective Date:	Aug 1, 2014		Quote/DTPO/CO:	Q15600201
Prepared by:	Scott Pekar		Version Number:	34.00

Description	Weight
Rider seat: Kenworth Toolbox Plus HB cloth. Standard features include fixed base and backrest, tool box seat base w/ door, and dual armrests. Seat cushion is 19.5 inches. Seat material has a horizontal stitch pattern and is 2-tone in color. Seat back is carpeted with a map pocket. Seat is manufactured by National. Includes inside visor and retractable 3-point matching seat belts. Black seat belts for T700, gray on all other models.	0
Seat color: Dark Slate Gray.	0
Kenworth Radio with AM/FM/WB/CD/USB and Bluetooth	4
CB installation kit: Center mounted of header. W/header mounted quick release CB mount. One red power post & one black ground post. Includes dual antenna leads located on the mirror brackets. Includes dual antenna & separate speaker.	2
Non-self cancelling turn signal: W/column-mounted headlight dimmer switch & intermittent wiper control.	0
Electric LH & RH door locks.	0
Long grabhandle RH side of cab.	0
Long grabhandle LH side of cab.	0
Grabhandle LH inside door frame above dash.	0
Grabhandle RH inside door frame above dash.	0
Varashield wind deflector w/ manual angle control.	61
DAYLITE DOOR: LH/RH INCL RH PEEPER WINDOW	0
Single air horn under cab.	0
Single convex mirror 8-1/2 in. x 4-7/16 in. located on rider side, and non-heated.	0
Mirror: Dual Kenworth aerodynamic heated motorized 7 in. x 13 in. mirror w/ chrome shell. LH/RH convex mirrors 5 in. x 7 in. heated. Mirror brackets set for 8 1/2 ft load width. Switch located on door pad.	26
Rear Cab Stationary Window 17 in. x 36 in.	0
Electric-powered LH & RH door window lifts. Switch located on door.	0
One-piece windshield, w/ curved glass.	0
Exterior aerodynamic sunvisor w/ integral marker lights.	0
Link Cabmate suspension.	22
Lights & Instruments	
Headlamps: Dual Rectangular, extended life halogen	0
Marker Lights: Five aerodynamic, LED mounted in sunvisor.	0

Unpublished options may require review/approval.
Dimensional and performance data for unpublished options may vary from that displayed in PROSPECTOR.

Printed:	10/21/2014 11:09:54 AM	Complete	Model Number:	T800 Series Conventional.
Effective Date:	Aug 1, 2014		Quote/DTPO/CO:	Q15600201
Prepared by:	Scott Pekar		Version Number:	34.00

Description	Weight
Turn Signal Lights: LED, mounted on fender	0
LED Stop, Turn, Tail: Flange Mounted With Two LED backup lights and with an LED license plate.	0
Dual Flush Floodlights: First set. Each floodlight includes one switch.	2
Floodlight Location: Located mid - first set.	0
Marker Lights: Interrupter switch. Included in Turn Signal for all models except T3. The T3 switch is in the dash.	0
Circuit Breakers: Replacing fuses. Does not apply to any 5-amp fuse box position. Breakers include stop/brake/turn, tail lamp, high & low beams, marker/clearance lamps, horn, fuel heat, gauges, wipers, air dryer, HVAC controls, panel lamps.	0
Air Equipment	
Air Dryer: Bendix AD-IS heated.	0
Moisture ejection valve: Midland automatic use w/ AD-IS only.	2
Full truck/tractor kit combined: LH frame mounted 7-way female receptacle and air connection gladhands are mounted BOC on LH frame bracket & mounted at end-of-frame in taillamp bracket. Kit includes dash mounted trailer air supply valve, trailer hand control valve, and hoses/fittings for the valves. Dash mounted parking brake valve, tractor protection valve, and spring brake inversion/relay valve are standard.	15
Air and light line length 12 feet	0
Straight air & light lines: for semitrailer application. Air lines detachable one end only; light line detachable both ends. Use w/ code 9110030. Note must code separately for straight air & light line lengths. Requires 12ft straight air & light.	8
Nylon air tubing in frame & cab, excluding hoses subject to excessive heat or flexing.	0
Trailer ABS electric supply through SAE J560 7-pin connector per TMC RP137).	0
Standard hoesenna Bracket Location. Hoesenna bracket will be located 0- six inches from any non-standard location requested	0
Extended Warranty	
Standard Warranty.	0
EW: US Basic Vehicle 3 year/300,000 miles, United States only.	0

Unpublished options may require review/approval.
Dimensional and performance data for unpublished options may vary from that displayed in PROSPECTOR.

Printed:	10/21/2014 11:09:54 AM	Complete	Model Number:	T800 Series Conventional.
Effective Date:	Aug 1, 2014		Quote/DTPO/CO:	Q15600201
Prepared by:	Scott Pekar		Version Number:	34.00



Description	Weight
Cummins EW: Protection Plan 1, 2013 ISX12/15 - 3 Years / 300,000 miles (482,804 km), up to 450HP. Each code registered between 366 and 546 days after the vehicle's in-service date will be subject to a \$400 late fee. Coverage cannot be added after 200,000 miles or 545 days past the in-service date.	0
Cummins EW: Aftertreatment, use w/ Protection Plan 1, 2013 ISX12/15 - 3 Years / 300,000 miles (482,804 km), all HP. Each code registered between 366 and 546 days after the vehicle's in-service date will be subject to a \$400 late fee. Coverage cannot be added after 200,000 miles or 545 days past the in-service date.	0
Heavy-duty Emissions Surcharge \$9250.	0
Miscellaneous	0
Paint	
Paint color number. N97020 A - L0006EB WHITE B/C N97400 SUNVISOR L0006EB WHITE B/C N97200 FRAME N0001EA BLACK	0
Imron solid 1 color non-sleeper Spec A. Will be White L0006EB if no other color specified.	0
Base coat/clear coat. The Kenworth Color Selector contains additional instructions, as well as information on Kenworth paint guidelines and surface finish applications. Kenworth is standard with Dupont Imron Elite paint.	0

Total Adjusted Price (W/O Freight & Warranty & Surcharges)	\$163,451
Freight Charge	\$2,125
Options Not Subject to Discount	\$4,875
Surcharges Not subject to Discount	\$9,250
Total Weight	16784

Prices and Specifications Subject to Change Without Notice.

Unpublished options may require review/approval.
Dimensional and performance data for unpublished options may vary from that displayed in PROSPECTOR.

Printed:	10/21/2014 11:09:54 AM	Complete	Model Number:	T800 Series Conventional.
Effective Date:	Aug 1, 2014		Quote/DTPO/CO:	Q15600201
Prepared by:	Scott Pekar		Version Number:	34.00

Worldwide Equipment W008
945 Nandino Blvd

State of West Virginia
2019 Washington street East

Lexington, Kentucky United States 40514
Phone: (800) 237-1878
Fax:
Email: scott.pekar@thetruckpeople.com

Charleston, West Virginia United States 25305
Phone: (304) 558-0468
Fax:
Contact Email:
Prepared for: Dean Wingerd

Horizontal Dimensions

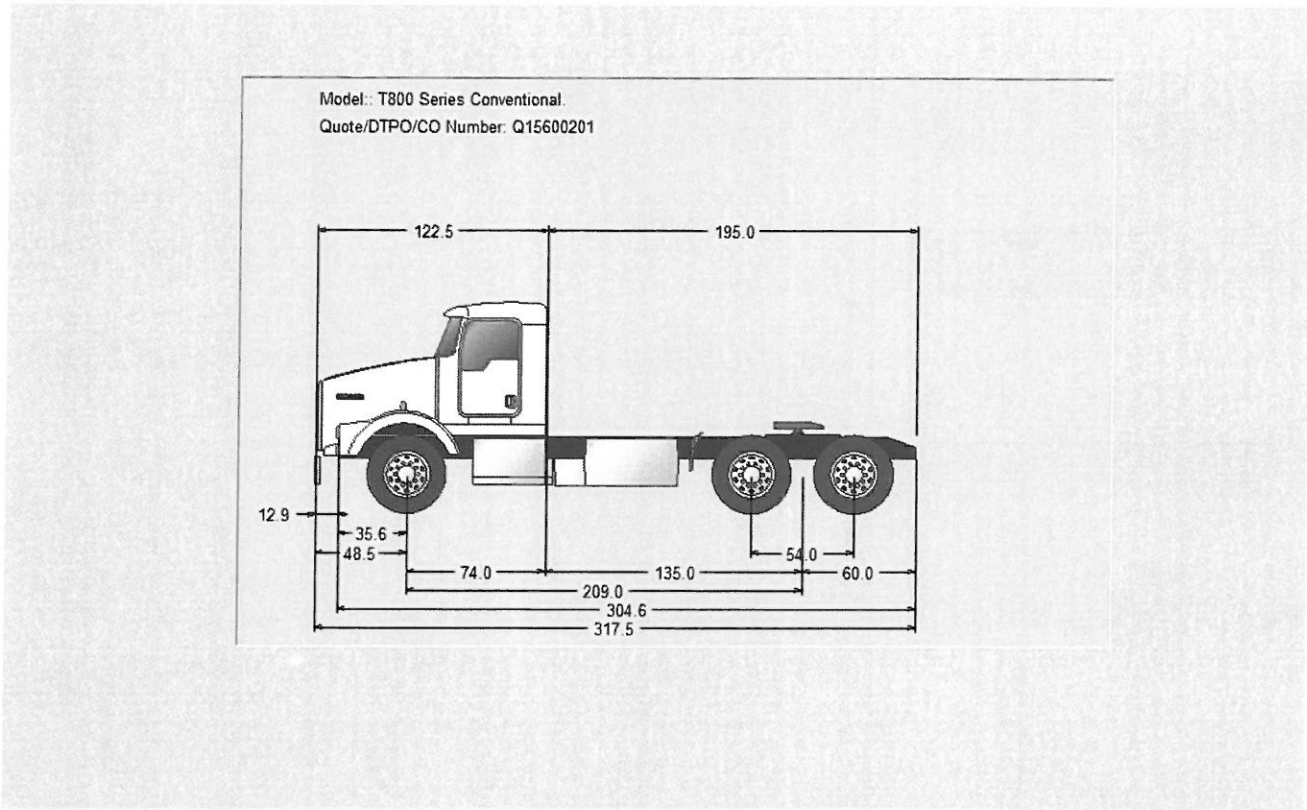

Unpublished options may require review/approval.
Dimensional and performance data for unpublished options may vary from that displayed in PROSPECTOR.

Printed:	10/21/2014 11:10:18 AM	Complete	Model Number:	T800 Series Conventional.
Effective Date:	Aug 1, 2014		Quote/DTPO/CO:	Q15600201
Prepared by:	Scott Pekar		Version Number:	34.00



Worldwide Equipment W008
945 Nandino Blvd

State of West Virginia
2019 Washington street East

Lexington, Kentucky United States 40514
Phone: (800) 237-1878
Fax:
Email: scott.pekar@thetruckpeople.com

Charleston, West Virginia United States 25305
Phone: (304) 558-0468
Fax:
Contact Email:
Prepared for: Dean Wingerd

Vehicle Weight Rating

Front Axle

Component	Code	Description	Weight (lbs)
Axle	2502203	Dana Spicer E-1202I Front Axle rated 12K	12,000
Springs	2863012	Front Springs: Taperleaf 12K w/ shock absorbers	12,000
Power Steering	2895121	Single power steering gear: 13.2K Sheppard M100P.	13,200
Hubs, Drums	2701300	Front Hub: aluminum hub pilot 13,200 lbs.	13,200
Brakes	2641113	Front Brakes, Meritor Q+ RSD-Compliant S-Cam 16.5x	14,600
Tires	4079051	Front tires: Bridgestone R250ED 11R22.5 16PR.	13,220
Wheels	5042264	Front wheel: Accuride 50487 22.5x8.25 steel	14,800

Requested Front Axle Rating is 12,000

Front Axle Weight Rating is limited to 12,000 #

Rear Axle

Component	Code	Description	Weight (lbs)
Axle	3124400	Dual Dana Spicer DSP40 rear axle rated at 40K.	40,000
Hubs, Drums	3407050	Dual Rear Hubs: Aluminum hub pilot 46K	46,000
Service Brakes	3354050	Rear Brakes, Meritor Q+ RSD-Compliant S-Cam	50,000
Spring Brakes	3485207	Spring Brake: 3030 long stroke dual 30 square	52,000
Suspension	3730026	Rear suspension: Tandem Kenworth Airglide 400L	40,000
Tires	4277487	Rear tires: Bridgestone M799 11R22.5 16PR.	48,040
Wheels	5242264	Rear wheel: Accuride 50487 22.5x8.25 steel	59,200

Requested Rear Axle Rating is 40,000

The Rear Axle Weight Rating is limited to 40,000 #

Tire rating is based on tire psi. Tire psi is based on the max wheel psi. The tire psi cannot exceed the wheel max psi.

Unpublished options may require review/approval.
Dimensional and performance data for unpublished options may vary from that displayed in PROSPECTOR.

Printed:	10/21/2014 11:10:51 AM	Incomplete	Model Number:	T800 Series Conventional.
Effective Date:	Aug 1, 2014		Quote/DTPO/CO:	Q15600201
Prepared by:	Scott Pekar		Version Number:	34.00

Warranty Quick Reference Guide – Class 8 Standard Service only

*This is a Quick Reference Guide **ONLY-Uncontrolled Document for Information Only**
 This is an itemized listing of the components and/or items used in the assembly of a Kenworth truck and their respective level of warranty coverage. This list is NOT to be construed as all inclusive.
 Refer to the Kenworth Warranty Agreement for specific details on the terms, conditions and limitations of said Warranty Agreement.*

BASIC VEHICLE WARRANTY 12 Months or 100,000 Miles/160,000 Kilometers whichever shall occur first 100% Parts and Labor			
Aerodynamic Devices Air Cleaner System (excluding Filter Element) Air Dryer Air Tanks Alternator Antenna Anti-Lock Brakes Axle Housing Gaskets Axles - Dual Speed (except Axle Shaft Gaskets and Wheel Seals) Batteries - PACCAR Brand Only Brake Chambers and Slack Adjusters Brake Drums (except when scored or heat checked) Bumper Cab Heater and Ducts Cab Paint (see below) Cab Suspension (including shock absorbers) Cab Water Leaks Charge Air Cooler Chassis Fairings (optional full length or partial) Clean Power System (including batteries) Clutch, Clutch Brake, Clutch Linkage Control Cables Cruise Control Components Deck Plate Door Latches and Locks	Door Pads and Soft Trim Drivelines, U-Joints and Center Bearing Electrical Power Distribution Box Electrical Printed Circuits Engine Dipstick and Tube (KW Only) Engine Fan Engine Fan Clutch and Sending Unit Engine Fan Shroud Engine Heater Engine Mounts Engine Shutdown System Exhaust Stanchion Exhaust System (excluding emissions system) Frame Paint - black only (see below) Freon Leaks Fuel Tank Straps, Cap and Vent Fuel Tanks (excluding finish) Fuel Water Separator and/or Heater Gauges and Sending Units GPS Heat Shields Hood Assist Springs and Hooks Horn - Air or Electric Hoses and Fittings Hub Assemblies (including Bearings) Hub Caps	Hubometer HVAC System Instruments Lamp Fixtures (excluding Bulbs) Mirrors Mud Flap Brackets (excluding Mud Flaps) Navigation System - NavPlus Oil Coolers O-Rings Plating (including Chrome) Power Steering Box Assembly Power Steering Pump Power Steering Reservoir Power Take Off Quarter Fenders Radiator (including Header Gaskets) Radio Roof Fairing Seat Belts Seat Structure Shift Controls Shock Absorbers and brackets Side Extenders Sleeper Boot, Shelves & Cabinets Smartwheel Speakers	Starter Steering Arm Steering Drag Link Steering Pitman Arm Steering Wheel Steps Suspension Switches Throttle Linkage and Cable Trailer Hitch and Stinger Transfer Case - Spicer Only (except Seals and Gaskets) Upholstery Valves, All Vents - Fresh Air Visor (outside and inside) Weather Stripping Wheel Bearings (except Seals and Gaskets) Window Defroster Fan Window Lift (including Power Lift) Windshield Washer Wiper Arms (excluding Blades) Wiper Motor and Control Valve Wiring and Connectors **Mounting brackets and bolts for above items**
EXTENDED COMPONENTS WARRANTY 36 Months or 300,000 Miles/480,000 Kilometers whichever shall occur first 100% Parts and Labor			
Axles, Non-Driving and Driving, On-Highway with a capacity of 46,000 lbs. or less (including Axle Input and Output Seals) (except Axle Shaft Flange Gaskets, Brake Drums, Brake Shoes, Filters, Hub Assemblies, Hub Caps and Gaskets, Wheel Bearings and Wheel Seals) Brakes Applies to Brackets, Cam Shafts and Spiders	Cab, Hood and Sleeper Structure (includes Door Hinges) Huck-Bolts (Cab and sleeper only) Transmissions - Manual		
EXTENDED COMPONENTS WARRANTY 60 Months or 500,000 Miles/800,000 Kilometers whichever shall occur first 100% Parts and Labor			
Frame Side Rails, Crossmembers, Gussets and Cab Corrosion Cab corrosion warranty applies to perforation - an actual hole in a cab panel due to corrosion. Warranty does not apply to corrosion caused by damage to a cab panel or finish paint			
OTHER COMPONENT WARRANTY 12 Months or 50,000 Miles/80,000 Kilometers whichever shall occur first 100% Parts and Labor			
Axle Shaft Flange Gaskets Hub Cap Gaskets	Wheel Seals		

<p>CAB PAINT 12 Months or 100,000 Miles/160,000 Kilometers whichever shall occur first 100% Parts and Labor</p> <p>Excludes Paint Chip and/or Fade</p> <p>FRAME PAINT (BLACK ONLY) 12 Months or 100,000 Miles/160,000 Kilometers whichever shall occur first 100% Parts and Labor</p> <p>Excludes Paint Chip and/or Fade Excluded Vehicle Applications: Logger, Mixer, Dump, Refuse, Oilfield & Construction</p>	<p>FRAME PAINT (OTHER THAN BLACK) 6 Months or 50,000 Miles/80,000 Kilometers whichever shall occur first 100% Parts and Labor</p> <p>Excludes Paint Chip and/or Fade Excluded Vehicle Applications: Logger, Mixer, Dump, Refuse, Oilfield & Construction</p> <p>FRAME PAINT 3 Months or 25,000 Miles/40,000 Kilometers whichever shall occur first 100% Parts and Labor</p> <p>Logger, Mixer, Dump, Refuse, Oilfield & Construction applications</p>																																															
<p>BREAK-IN ITEMS 90 days or 25,000 Miles/40,000 Kilometers whichever shall occur first</p>																																																
<p>Vibrations, Squeaks, Fitting & Hose Leaks, Unusual Noises, Rattles, Loose Bolts & Electrical Connections</p>																																																
<p>NON-WARRANTABLE COMPONENTS/ITEMS</p> <table border="0"> <tr> <td>Add-on Aerodynamic Devices (dealer installed)</td> <td>Lubricants</td> </tr> <tr> <td>Air Compressor</td> <td>Mattresses</td> </tr> <tr> <td>Air Starter</td> <td>Mudflaps</td> </tr> <tr> <td>Anti-freeze Solutions</td> <td>Non-Original Equipment</td> </tr> <tr> <td>Automatic Transmission (except Fuller Ceemat)</td> <td>Power Converter</td> </tr> <tr> <td>Batteries other than Kenworth std Data book brand</td> <td>Primers for Fuel, Primer and Water</td> </tr> <tr> <td>Cellular Telephone</td> <td>Reflectors</td> </tr> <tr> <td>Chains</td> <td>Refrigerator</td> </tr> <tr> <td>Cigar Lighter</td> <td>Rims</td> </tr> <tr> <td>C.B. Radio and Microphone</td> <td>Stereo Set</td> </tr> <tr> <td>Diesel Exhaust Fluid (DEF)</td> <td>Tachograph</td> </tr> <tr> <td>Electronic Trip Recorders</td> <td>Television Set, VCR, DVD player</td> </tr> <tr> <td>Engines - Except PACCAR MX Engines</td> <td>Tires</td> </tr> <tr> <td>Engine Accessories - Except PACCAR MX Engines</td> <td>Tools</td> </tr> <tr> <td>Engine Brake - Except PACCAR MX Engines</td> <td>Tow Pins</td> </tr> <tr> <td>Engine Governor - Except PACCAR MX Engines</td> <td>Trade Accessories</td> </tr> <tr> <td>Filters for Fuel, Oil and Water</td> <td>Tubes</td> </tr> <tr> <td>Fifth Wheel</td> <td>Turbocharger</td> </tr> <tr> <td>Filter Elements</td> <td>Turboconveyor or blower</td> </tr> <tr> <td>Fire Extinguisher</td> <td>Vehicle Theft Alarm</td> </tr> <tr> <td>Flag and Flare Kit</td> <td>Wheels</td> </tr> <tr> <td>Fuel</td> <td>Winter Front and Bug Screen</td> </tr> <tr> <td>Headlights and Light Bulbs</td> <td>Wiper Blades</td> </tr> </table> <p>This list is NOT to be construed as all inclusive.</p>	Add-on Aerodynamic Devices (dealer installed)	Lubricants	Air Compressor	Mattresses	Air Starter	Mudflaps	Anti-freeze Solutions	Non-Original Equipment	Automatic Transmission (except Fuller Ceemat)	Power Converter	Batteries other than Kenworth std Data book brand	Primers for Fuel, Primer and Water	Cellular Telephone	Reflectors	Chains	Refrigerator	Cigar Lighter	Rims	C.B. Radio and Microphone	Stereo Set	Diesel Exhaust Fluid (DEF)	Tachograph	Electronic Trip Recorders	Television Set, VCR, DVD player	Engines - Except PACCAR MX Engines	Tires	Engine Accessories - Except PACCAR MX Engines	Tools	Engine Brake - Except PACCAR MX Engines	Tow Pins	Engine Governor - Except PACCAR MX Engines	Trade Accessories	Filters for Fuel, Oil and Water	Tubes	Fifth Wheel	Turbocharger	Filter Elements	Turboconveyor or blower	Fire Extinguisher	Vehicle Theft Alarm	Flag and Flare Kit	Wheels	Fuel	Winter Front and Bug Screen	Headlights and Light Bulbs	Wiper Blades	<p>NON-WARRANTABLE: WEAR, DETERIORATION and/or ADJUSTMENTS</p> <p>Kenworth assumes no responsibility for wear and/or deterioration of parts or changes in adjustment as a result of normal service.</p> <p>Examples: Aluminum, Chrome or Stainless Steel: Discoloration or pitting Axle and/or Wheel Alignment Belts Brake Adjustment Brake Linings Circuit Breakers Tools Clutch Facings Door Adjustment Fuses Hood Adjustment Leveling of Vehicle Soft Trim and Upholstery Tightening Bolts and/or Fittings Window and Windshield Glass</p> <p>This list is NOT to be construed as all inclusive.</p>	<p>NON-WARRANTABLE FUNCTIONS OR ACTS</p> <p>Any vehicle on which the odometer has been altered. Any vehicle that has been altered or modified in a manner unauthorized by Kenworth.</p> <p>Damage due to accidents Environment Dyno testing (without prior regional authorization) Impact Improper operation Improper or insufficient maintenance service Misuse Negligence Overtime Labor Storage (including deterioration) Towing and Road Calls Transport Troubleshooting and Road Testing</p> <p>This list is NOT to be construed as all inclusive.</p>
Add-on Aerodynamic Devices (dealer installed)	Lubricants																																															
Air Compressor	Mattresses																																															
Air Starter	Mudflaps																																															
Anti-freeze Solutions	Non-Original Equipment																																															
Automatic Transmission (except Fuller Ceemat)	Power Converter																																															
Batteries other than Kenworth std Data book brand	Primers for Fuel, Primer and Water																																															
Cellular Telephone	Reflectors																																															
Chains	Refrigerator																																															
Cigar Lighter	Rims																																															
C.B. Radio and Microphone	Stereo Set																																															
Diesel Exhaust Fluid (DEF)	Tachograph																																															
Electronic Trip Recorders	Television Set, VCR, DVD player																																															
Engines - Except PACCAR MX Engines	Tires																																															
Engine Accessories - Except PACCAR MX Engines	Tools																																															
Engine Brake - Except PACCAR MX Engines	Tow Pins																																															
Engine Governor - Except PACCAR MX Engines	Trade Accessories																																															
Filters for Fuel, Oil and Water	Tubes																																															
Fifth Wheel	Turbocharger																																															
Filter Elements	Turboconveyor or blower																																															
Fire Extinguisher	Vehicle Theft Alarm																																															
Flag and Flare Kit	Wheels																																															
Fuel	Winter Front and Bug Screen																																															
Headlights and Light Bulbs	Wiper Blades																																															
<p>Off-Highway /Severe Service Vehicles</p> <p>Severe Service Warranty is based on a Kenworth chassis having one of the following: Unlicensed off-road registration, all-wheel drive, twin steer axles, all front steer axles rated @ 21,000 lbs. GAWR or greater, single rear drive axles rated @ 26,000 lbs. GAWR or greater, tandem rear axles rated @ 52,000 lbs. GAWR or greater, or 10% or more class C and/or D usage.</p>																																																



**WORLDWIDE
EQUIPMENT**

THE TRUCK PEOPLE

**Kenworth
Volvo
Mack
Isuzu**



**Charleston Division
304-744-1321**

General Manager | Matt Cochran

**Huntington Division
304-736-3401**

General Manager | Matt Cochran



**Jane Lew Division
304-884-7815**

General Manager | Greg St. Clair



**Princeton Division
304-425-7511**

General Manager | Randy Terry

SALES - SERVICE - PARTS - LEASING

WWW.THETRUCKPEOPLE.COM



**WORLDWIDE
EQUIPMENT**

COMPANY FACTS

About our Company

WORLDWIDE EQUIPMENT's story begins in 1967. Understanding the need for a heavy-duty truck dealer to successfully serve the coal industry of Eastern Kentucky, **WE** acquired its first **MACK®** franchise in Prestonsburg, Kentucky. **WE** quickly developed relationships with local businesses and drivers that have now grown for over 40 years. **WE** added the Kenworth, Volvo, Hino, and Isuzu brands to our medium and heavy-duty lines. Over time, **WE** have expanded our locations to full-service dealerships, satellite parts stores and leasing facilities in Tennessee, Kentucky, South Carolina, Ohio, Virginia, and West Virginia.

Our history assures you that you can depend on us to be here to provide the products and services you need for as long as you own your trucks. Our strong financial position, large coverage area, and experienced personnel allow us to provide very competitive pricing and premium services not readily available from other dealerships.

Stop by one of our locations today to see how **WORLDWIDE EQUIPMENT** is changing the trucking industry.

Quick Facts

- Established **1967**
- President, CEO: Terry Dotson
- Over **900** employees
- Trucks - Mack, Volvo, Kenworth, Hino, Isuzu | Trailers - East, Featherlite, Dorsey, Dynaweld
- **36** Locations: **16** full-service dealerships | **5** parts locations | **15** leasing offices | **1** full-detail shop | **1** fabrication facility
- Along major Interstates: I-81, I-40, I-64, I-79, I-24, I-75, I-77, I-26, I-85



SALES

New & Used Truck & Trailer
Mack
Volvo
Kenworth
Hino
Isuzu
Dorsey
East
Featherlite
Dynaweld



PARTS

Truck & Trailer Parts
Private Label Parts Brand:
Road Champion
An average of \$20 million
continuously stocked parts
in inventory



SERVICE

Truck & Trailer Parts
Over 250 Full-Service Bays
Heavy-Duty Diesel Service
Certifications:
CAT, Cummins, GMC



FINANCING & INSURANCE



LEASING & RENTAL

Medium & Heavy Duty
Long-term leasing
Short-term rental

SPECIALTY SERVICE

Body & Detail Shop
Collision Repair
Frame & Alignment work
Fabrication
Manufacturing
CT Tank Inspection & Repair
Crane Inspection





Directory

KENTUCKY

SALES / SERVICE

LEXINGTON
859-281-5152
945 Nandino Drive
Lexington, KY 40511



MIDDLESBORO
606-248-5100
Mack Avenue, Industrial Park
Middlesboro, KY 40965



PRESTONSBURG
606-874-2172
107 We Drive
Prestonsburg, KY 41653



SOMERSET
606-679-4321
208 Industry Road
Somerset, KY 42501



LEASING

LEXINGTON
859-233-3740
1677 Jaggie Fox Way
Lexington, KY 40511

ASHLAND
606-928-1129
1026 US Route 60
Ashland, KY 41102

BETSY LAYNE
606-478-9552
155 KY Oil Village
Betsy Layne, KY 41605

LONDON
606-878-1418
252 South Barboursville Road
London, KY 40744

SOMERSET
606-274-4020
4001 Old Barnesburg Road
Somerset, KY 42501

PARTS ONLY

LONDON
606-877-3012
1210 Mardis Street
London, KY 40741

PIKEVILLE
606-437-0130
1188 South Mayo Trail
Pikeville, KY 41501

SPECIALTY

Worldwide Fabrication
606-297-1200
85 August Circle
Lowmansville, KY 41232

OHIO

SALES / SERVICE

CINCINNATI
513-563-6363
10649 Evendale Drive
Cincinnati, OH 45241

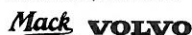

DAYTON
937-278-5775
5750 Poe Avenue
Dayton, OH 45414



LEASING

CINCINNATI
513-577-8001
10649 Evendale Drive
Cincinnati, OH 45241

SOUTH CAROLINA

SALES / SERVICE

CHARLESTON
843-725-5378
2755 Azalea Drive
North Charleston, SC 29405



COLUMBIA
803-926-2900
707 Cherokee Lane
West Columbia, SC 29169



GREENVILLE
864-220-3033
2727 White Horse Road
Greenville, SC 29611



LEASING

CHARLESTON
843-725-5358
2755 Azalea Drive
North Charleston, SC 29405

COLUMBIA
803-926-2900
707 Cherokee Lane
West Columbia, SC 29169

GREENVILLE
864-220-2509
1055 Park West Blvd.
Greenville, SC 29611

TENNESSEE

SALES / SERVICE

CHATTANOOGA
423-698-4093
2017 East 23rd Street
Chattanooga, TN 37404

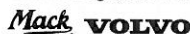

KNOXVILLE
865-688-4300
6614 Wilbanks Road
Knoxville, TN 37912



LEASING

KNOXVILLE
865-637-4341
6416 Asheville Highway
Knoxville, TN 37914

JOHNSON CITY
423-207-0511
801 Suncrest Drive
Johnson City, TN 37615

PARTS ONLY

JOHNSON CITY
423-207-0504
801 Suncrest Drive
Johnson City, TN 37615

SPECIALTY

Complete Truck & Trailer
865-637-4333
6416 Asheville Highway
Knoxville, TN 37914

VIRGINIA

SALES / SERVICE

ABINGDON
276-628-8103
18285 Lee Highway
Abingdon, VA 24210



PARTS ONLY

NORTON
276-679-1553
442 Kentucky Avenue
Norton, VA 24273

WEST VIRGINIA

SALES / SERVICE

CHARLESTON
304-744-1321
3100 MacCorkle Avenue SW
South Charleston, WV 25303



HUNTINGTON
304-736-3401
5650 US Route 60 East
Huntington, WV 25703



JANE LEW
304-884-7815
Lewis County Industrial Park
Jane Lew, WV 26378



PRINCETON
304-425-7511
406 Turnpike Industrial Road
Princeton, WV 24740



LEASING

CHARLESTON
304-744-1321
3100 MacCorkle Avenue SW
South Charleston, WV 25303

CLARKSBURG
304-624-0505
1129 East Pike Street
Clarksburg, WV 26301

HUNTINGTON
304-523-4567
120 13th Street West
Huntington, WV 25704

PARKERSBURG
304-489-2115
2817 Pike Street
Parkersburg, WV 26101

PARTS ONLY

SUMMERSVILLE
304-872-6044
5310 Webster Road
Summersville, WV 26651

History of Worldwide Equipment

Since 1967



WORLDWIDE
EQUIPMENT
THE TRUCK PEOPLE

VENDOR PREFERENCE CERTIFICATE

Certification and application* is hereby made for Preference in accordance with West Virginia Code, §5A-3-37. (Does not apply to construction contracts). West Virginia Code, §5A-3-37, provides an opportunity for qualifying vendors to request (at the time of bid) preference for their residency status. Such preference is an evaluation method only and will be applied only to the cost bid in accordance with the West Virginia Code. This certificate for application is to be used to request such preference. The Purchasing Division will make the determination of the Vendor Preference, if applicable.

1. Application is made for 2.5% vendor preference for the reason checked:

____ Bidder is an individual resident vendor and has resided continuously in West Virginia for four (4) years immediately preceding the date of this certification; or,

____ Bidder is a partnership, association or corporation resident vendor and has maintained its headquarters or principal place of business continuously in West Virginia for four (4) years immediately preceding the date of this certification; or 80% of the ownership interest of Bidder is held by another individual, partnership, association or corporation resident vendor who has maintained its headquarters or principal place of business continuously in West Virginia for four (4) years immediately preceding the date of this certification; or,

X Bidder is a nonresident vendor which has an affiliate or subsidiary which employs a minimum of one hundred state residents and which has maintained its headquarters or principal place of business within West Virginia continuously for the four (4) years immediately preceding the date of this certification; or,

2. Application is made for 2.5% vendor preference for the reason checked:

____ Bidder is a resident vendor who certifies that, during the life of the contract, on average at least 75% of the employees working on the project being bid are residents of West Virginia who have resided in the state continuously for the two years immediately preceding submission of this bid; or,

3 X Application is made for 2.5% vendor preference for the reason checked:

____ Bidder is a nonresident vendor employing a minimum of one hundred state residents or is a nonresident vendor with an affiliate or subsidiary which maintains its headquarters or principal place of business within West Virginia employing a minimum of one hundred state residents who certifies that, during the life of the contract, on average at least 75% of the employees or Bidder's affiliate's or subsidiary's employees are residents of West Virginia who have resided in the state continuously for the two years immediately preceding submission of this bid; or,

4 X Application is made for 5% vendor preference for the reason checked:

____ Bidder meets either the requirement of both subdivisions (1) and (2) or subdivision (1) and (3) as stated above; or,

5. Application is made for 3.5% vendor preference who is a veteran for the reason checked:

____ Bidder is an individual resident vendor who is a veteran of the United States armed forces, the reserves or the National Guard and has resided in West Virginia continuously for the four years immediately preceding the date on which the bid is submitted; or,

6. Application is made for 3.5% vendor preference who is a veteran for the reason checked:

____ Bidder is a resident vendor who is a veteran of the United States armed forces, the reserves or the National Guard, if, for purposes of producing or distributing the commodities or completing the project which is the subject of the vendor's bid and continuously over the entire term of the project, on average at least seventy-five percent of the vendor's employees are residents of West Virginia who have resided in the state continuously for the two immediately preceding years.

7. Application is made for preference as a non-resident small, women- and minority-owned business, in accordance with West Virginia Code §5A-3-59 and West Virginia Code of State Rules.

____ Bidder has been or expects to be approved prior to contract award by the Purchasing Division as a certified small, women- and minority-owned business.

Bidder understands if the Secretary of Revenue determines that a Bidder receiving preference has failed to continue to meet the requirements for such preference, the Secretary may order the Director of Purchasing to: (a) reject the bid; or (b) assess a penalty against such Bidder in an amount not to exceed 5% of the bid amount and that such penalty will be paid to the contracting agency or deducted from any unpaid balance on the contract or purchase order.

By submission of this certificate, Bidder agrees to disclose any reasonably requested information to the Purchasing Division and authorizes the Department of Revenue to disclose to the Director of Purchasing appropriate information verifying that Bidder has paid the required business taxes, provided that such information does not contain the amounts of taxes paid nor any other information deemed by the Tax Commissioner to be confidential.

Under penalty of law for false swearing (West Virginia Code, §61-5-3), Bidder hereby certifies that this certificate is true and accurate in all respects; and that if a contract is issued to Bidder and if anything contained within this certificate changes during the term of the contract, Bidder will notify the Purchasing Division in writing immediately.

Bidder: Worldwide Equipment Inc

Signed: [Signature]

Date: 10/21/14

Title: Director of Government & Municipal Sales

RFQ No. AGR1500000004

STATE OF WEST VIRGINIA
Purchasing Division

PURCHASING AFFIDAVIT

MANDATE: Under W. Va. Code §5A-3-10a, no contract or renewal of any contract may be awarded by the state or any of its political subdivisions to any vendor or prospective vendor when the vendor or prospective vendor or a related party to the vendor or prospective vendor is a debtor and: (1) the debt owed is an amount greater than one thousand dollars in the aggregate; or (2) the debtor is in employer default.

EXCEPTION: The prohibition listed above does not apply where a vendor has contested any tax administered pursuant to chapter eleven of the W. Va. Code, workers' compensation premium, permit fee or environmental fee or assessment and the matter has not become final or where the vendor has entered into a payment plan or agreement and the vendor is not in default of any of the provisions of such plan or agreement.

DEFINITIONS:

"Debt" means any assessment, premium, penalty, fine, tax or other amount of money owed to the state or any of its political subdivisions because of a judgment, fine, permit violation, license assessment, defaulted workers' compensation premium, penalty or other assessment presently delinquent or due and required to be paid to the state or any of its political subdivisions, including any interest or additional penalties accrued thereon.

"Employer default" means having an outstanding balance or liability to the old fund or to the uninsured employers' fund or being in policy default, as defined in W. Va. Code § 23-2c-2, failure to maintain mandatory workers' compensation coverage, or failure to fully meet its obligations as a workers' compensation self-insured employer. An employer is not in employer default if it has entered into a repayment agreement with the Insurance Commissioner and remains in compliance with the obligations under the repayment agreement.

"Related party" means a party, whether an individual, corporation, partnership, association, limited liability company or any other form or business association or other entity whatsoever, related to any vendor by blood, marriage, ownership or contract through which the party has a relationship of ownership or other interest with the vendor so that the party will actually or by effect receive or control a portion of the benefit, profit or other consideration from performance of a vendor contract with the party receiving an amount that meets or exceeds five percent of the total contract amount.

AFFIRMATION: By signing this form, the vendor's authorized signer affirms and acknowledges under penalty of law for false swearing (W. Va. Code §61-5-3) that neither vendor nor any related party owe a debt as defined above and that neither vendor nor any related party are in employer default as defined above, unless the debt or employer default is permitted under the exception above.

WITNESS THE FOLLOWING SIGNATURE:

Vendor's Name: Worldwide Equipment Inc
Authorized Signature: [Signature] Date: 10/21/14

State of tn

County of KNOX, to-wit:

Taken, subscribed, and sworn to before me this 21ST day of OCTOBER, 2014.

My Commission expires 05-06-18, 20 .

AFFIX SEAL HERE

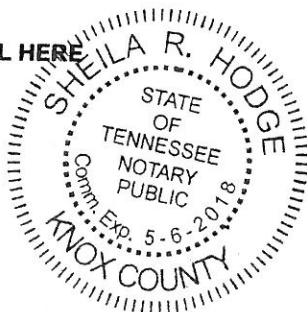

NOTARY PUBLIC

Sheila R. Hodge