



Purchasing Division
 2019 Washington Street East
 Post Office Box 50130
 Charleston, WV 25305-0130

State of West Virginia
 Request for Quotation

—

Proc Folder: 32764

Doc Description: ADDENDUM NO. 4- megapixel camera security system

Proc Type: Central Purchase Order

Date Issued	Solicitation Closes	Solicitation No	Version
2014-11-12	2014-11-20 13:30:00	CRFQ 0618 BVH1500000003	5

BID RECEIVING LOCATION

BID CLERK
 DEPARTMENT OF ADMINISTRATION
 PURCHASING DIVISION
 2019 WASHINGTON ST E
 CHARLESTON WV 25305
 US

VENDOR

Vendor Name, Address and Telephone Number:

Mountain State Building Automation, LLC
 6444 Sissonville Dr
 Sissonville, WV 25320
 (304) 984-0414 FAX (304) 984-0124

11/20/14 13:16:38
 West Virginia Purchasing Division

FOR INFORMATION CONTACT THE BUYER

Dean Wingerd
 (304) 558-0468
 dean.c.wingerd@wv.gov

Signature X

FEIN # 26-3312652

DATE 11/20/14

All offers subject to all terms and conditions contained in this solicitation

INVOICE TO		SHIP TO	
WEST VIRGINIA VETERANS HOME 512 WATER ST		WEST VIRGINIA VETERANS HOME 512 WATER ST	
BARBOURSVILLE	WV25504	BARBOURSVILLE	WV 25504
US		US	

Line	Comm Ln Desc	Qty	Unit Issue	Unit Price	Total Price
1	5 megapixel cameras (14)	14.00000	EA	\$1060.00	\$14,840.00

Comm Code	Manufacturer	Specification	Model #
46171610	ARECWT	5.0mp	AV 5255 Am 1RH

Extended Description :

*THE WEST VIRGINIA PURCHASING DIVISION ON BEHALF OF THE AGENCY, WEST VIRGINIA VETERANS HOME, IS SOLICITING BIDS TO ESTABLISH A CONTRACT TO INCLUDE THE FURNISHING OF ALL LABOR, EQUIPMENT, MATERIALS, AND PERFORMANCE OF ALL OPERATIONS ASSOCIATED WITH THE INSTALLATION OF A CAMERA SECURITY SYSTEM AS SHOWN ON THE DRAWINGS AND AS HEREIN SPECIFIED, FOR THE WV VETERANS HOME IN BARBOURSVILLE, WV, PER THE ATTACHED SPECIFICATIONS.**

.LINE NUMBER 1- Avigilon 5.0-H3-BO1-IR or equal cameras as per the attached specifications

INVOICE TO		SHIP TO	
WEST VIRGINIA VETERANS HOME 512 WATER ST		WEST VIRGINIA VETERANS HOME 512 WATER ST	
BARBOURSVILLE	WV25504	BARBOURSVILLE	WV 25504
US		US	

Line	Comm Ln Desc	Qty	Unit Issue	Unit Price	Total Price
2	2 megapixel outdoor cameras (2)	2.00000	EA	\$ 915.00	\$ 1830.00

Comm Code	Manufacturer	Specification	Model #
46171610	ARECWT	2.0mp	AV2255 AMIRAH

Extended Description :

Avigilon 2.0-H3-BO1-IR or equal cameras as per the attached specifications

INVOICE TO		SHIP TO	
WEST VIRGINIA VETERANS HOME 512 WATER ST		WEST VIRGINIA VETERANS HOME 512 WATER ST	
BARBOURSVILLE	WV25504	BARBOURSVILLE	WV 25504
US		US	

Line	Comm Ln Desc	Qty	Unit Issue	Unit Price	Total Price
3	1 megapixel indoor cameras in ceiling (5)	5.00000	EA	\$ 580.00	\$ 2900.00

Comm Code	Manufacturer	Specification	Model #
46171610	ARECONT	13MP 1.3MP	AV1255DN

Extended Description :
Avigilon 1.0-H3-DC1 or equal cameras as per the attached specifications

INVOICE TO		SHIP TO	
WEST VIRGINIA VETERANS HOME 512 WATER ST		WEST VIRGINIA VETERANS HOME 512 WATER ST	
BARBOURSVILLE	WV25504	BARBOURSVILLE	WV 25504
US		US	

Line	Comm Ln Desc	Qty	Unit Issue	Unit Price	Total Price
4	Network Video Recorder with 10.0 TB storage	1.00000	EA	\$ 5200	\$ 5200

Comm Code	Manufacturer	Specification	Model #
52161545	EXACQ	12TB	1P504012TR2

Extended Description :
Avigilon HD-NVR2 or equal as per the attached specifications

INVOICE TO		SHIP TO	
WEST VIRGINIA VETERANS HOME 512 WATER ST		WEST VIRGINIA VETERANS HOME 512 WATER ST	
BARBOURSVILLE	WV25504	BARBOURSVILLE	WV 25504
US		US	

Line	Comm Ln Desc	Qty	Unit Issue	Unit Price	Total Price
5	installation of camera system	1		\$39,500	\$ 39,500

Comm Code	Manufacturer	Specification	Model #
72151700			

Extended Description :
as per the attached specifications

INSTALLATION, MISC. MATERIAL & 1ST YEAR WARRANTY

INVOICE TO		SHIP TO	
WEST VIRGINIA VETERANS HOME 512 WATER ST		WEST VIRGINIA VETERANS HOME 512 WATER ST	
BARBOURSVILLE	WV25504	BARBOURSVILLE	WV 25504
US		US	

Line	Comm Ln Desc	Qty	Unit Issue	Unit Price	Total Price
6	Year (2) two ongoing support of installed camera system	0.00000	YR	\$ 7500	\$ 7500

Comm Code	Manufacturer	Specification	Model #
92121701			

Extended Description :
including IT support and repairs

INVOICE TO		SHIP TO	
WEST VIRGINIA VETERANS HOME 512 WATER ST		WEST VIRGINIA VETERANS HOME 512 WATER ST	
BARBOURSVILLE	WV25504	BARBOURSVILLE	WV 25504
US		US	

Line	Comm Ln Desc	Qty	Unit Issue	Unit Price	Total Price
7	Year (3) two ongoing support of installed camera system	1.00000	YR	\$ 7500	\$ 7500

Comm Code	Manufacturer	Specification	Model #
92121701			

Extended Description :
including IT support and repairs

INVOICE TO		SHIP TO	
WEST VIRGINIA VETERANS HOME 512 WATER ST		WEST VIRGINIA VETERANS HOME 512 WATER ST	
BARBOURSVILLE	WV25504	BARBOURSVILLE	WV 25504
US		US	

Line	Comm Ln Desc	Qty	Unit Issue	Unit Price	Total Price
8	Year (4) two ongoing support of installed camera system	0.00000	YR	\$ 7500	\$ 7500

Comm Code	Manufacturer	Specification	Model #
32121701			

Extended Description :
including IT support and repairs

INVOICE TO	SHIP TO
WEST VIRGINIA VETERANS HOME 512 WATER ST BARBOURSVILLE WV25504 US	WEST VIRGINIA VETERANS HOME 512 WATER ST BARBOURSVILLE WV 25504 US

Line	Comm Ln Desc	Qty	Unit Issue	Unit Price	Total Price
9	5 megapixel cameras (1)	1.00000	EA	\$ 1060	\$ 1060

Comm Code	Manufacturer	Specification	Model #
46171610	ARECONT	S.omp	AV5255AMIR#

Extended Description :
Avigilon 5.0-H3-BO2-IR or equal cameras as per the attached specifications

INVOICE TO	SHIP TO
WEST VIRGINIA VETERANS HOME 512 WATER ST BARBOURSVILLE WV25504 US	WEST VIRGINIA VETERANS HOME 512 WATER ST BARBOURSVILLE WV 25504 US

Line	Comm Ln Desc	Qty	Unit Issue	Unit Price	Total Price
10	1 megapixel indoor dome cameras (1)	1.00000	EA	\$ 580.00	\$ 580.00

Comm Code	Manufacturer	Specification	Model #
46171610	ARECONT	1.3mp	AV1255DN

Extended Description :
Avigilon 1.0-H3-DC1 or equal cameras as per the attached specifications

INVOICE TO		SHIP TO	
WEST VIRGINIA VETERANS HOME 512 WATER ST		WEST VIRGINIA VETERANS HOME 512 WATER ST	
BARBOURSVILLE	WV25504	BARBOURSVILLE	WV 25504
US		US	

Line	Comm Ln Desc	Qty	Unit Issue	Unit Price	Total Price
11	1500VA rack mountable UPS (uninterrupted power supply)	1.00000	EA	\$ 1000. ⁰⁰	\$ 1000. ⁰⁰

Comm Code	Manufacturer	Specification	Model #
39121011			

Extended Description :
JPS - APC model #SUA1500RM2U or equal as per specifications

INVOICE TO		SHIP TO	
WEST VIRGINIA VETERANS HOME 512 WATER ST		WEST VIRGINIA VETERANS HOME 512 WATER ST	
BARBOURSVILLE	WV25504	BARBOURSVILLE	WV 25504
US		US	

Line	Comm Ln Desc	Qty	Unit Issue	Unit Price	Total Price
12	training sessions for camera system	24.00000	HOUR	\$ 65. ⁰⁰	\$ 1560

Comm Code	Manufacturer	Specification	Model #
36000000			

Extended Description :
raining sessions with a minimum of 24 hours as per the specifications.

BVH150000003	Document Phase Final	Document Description ADDENDUM NO. 4- megapixel came ra security system	Page 7 of 7
--------------	--------------------------------	---	------------------------------

ADDITIONAL TERMS AND CONDITIONS

See attached document(s) for additional Terms and Conditions



exacqVision *A-Series*

IP Camera Servers
IP Cameras and Encoders

exacqVision A-Series IP Camera Servers

Reliable, Professional Grade Systems

Key Features & Benefits:

- **All-in-One Solution** — Video recording, web/mobile client hosting, and local live video display from the same server.
- **Network Video Recording Servers - IP Camera Servers** — Record IP cameras and encoders. Live and recorded video viewable through free exacqVision client application.
- **Up to 64 IP Cameras Per Server** — Up to 64 IP cameras per server. Compatible with over 1,800 IP camera models. Continuously record up to 550Mbps of video. Use our configuration calculator to find the perfect exacqVision server for your application.
- **Enterprise-Class Storage** — Up to 32 TB of storage per server using continuous duty enterprise-class drives. Optional RAID on 4U models.
- **Cross-Compatible Local, Remote and Mobile User Interfaces** — Access live and recorded video on multiple client PCs with free Windows, Mac or Linux client application. exacqVision web server application is pre-installed on the server to access video through a web browser or free Mobile iPhone/iPad and Android apps.
- **Professional Chassis for all Requirements** — 2U and 4U rackmount chassis ideal for server rooms with optional rack mounting kits. Compact desktop chassis ideal for space constrained applications.
- **Unlimited Scalability** — Pre-loaded with exacqVision Professional video management system (VMS) software. Easily add additional IP camera licenses and change out cameras. Add unlimited additional servers for greater capacity or dispersed geographic location. Manage individual systems from the same user interface or upgrade to exacqVision enterprise to easily manage multiple servers simultaneously.
- **CPU Upgrade Option** — Available CPU upgrade option increases local client and web server performance up to 100% and enables hosting of Certified Software Applications (CSA) such as video analytics or point-of-sale interfaces on exacqVision servers. CSAs are software developed by Exacq technology partners and tested by Exacq for reliable operation on exacqVision servers. Save hardware costs, rack space, and support costs by loading multiple applications on one exacqVision server.
- **3-Year Hardware Warranty, 3-Year Software Subscription Agreement (SSA)** — 3-year hardware warranty and SSA included. Update client, server and web server software with the latest exacqVision software features at no additional cost during the 3-year SSA period.

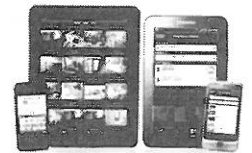

Camera Settings	2U	4U	Desktop
Maximum IP Cameras	Expandable up to 64 cameras per server (data rate dependent)		
Included IP Licenses	4	4	4
Server	2U	4U	
Pre-Loaded VMS Software	exacqVision Professional (standard), exacqVision Enterprise Server (optional)		
Typical Video Storage Rate (Mbps)	300Mbps (Windows), 450Mbps (Linux)	350Mbps (Windows), 550 Mbps (Linux)	250Mbps (Windows), 300Mbps (Linux)
Local Client Display Rate (FPS)	450/750 (Windows, Standard/Optional CPU) 300/500 (Linux, Standard / Optional CPU)		
Maximum Hard Drives	3	8	2
Maximum Storage	12 TB	32 TB	8 TB
Monitor Output	1 DVI-I, 1 DVI-D, 1 Display Port, maximum 2 simultaneous monitors		
Operating System	Windows 7 64 bit, Windows 2008 R2 (Optional), Ubuntu Linux 10.04		
Operating System Drive	32 GB SSD (Linux), HD (Windows), 64 GB SSD (Optional)		
Processor	Gen 3 Intel® i3 (standard), Intel® Core i5 or i7 (optional)		
RAM	4 GB (standard), 8 GB (optional)		
NIC	2 (standard), 4 (optional)		
USB Ports	6 x USB 2.0, 2 x USB 3.0		
DVD/CD RW	Included		
Serial Connection	N/A	N/A	N/A
Audio Outputs	1	1	1
Keyboard & Mouse	Included		
General	2U	4U	
Dimensions (lxwxh)	21.25 x 16.75 x 3.5 in 54.7 x 42.6 x 8.9 cm	28 x 16.75 x 7 in 71.2 x 42.6 x 17.8 cm	15.675 x 13 x 5.375 in 39.7 x 33.1 x 14.6 in
Weight	27 – 31 lbs 12.3 – 14.1 kg	44 – 60 lbs. 20 – 27.3 kg	18.5 – 22 lbs. 8.4 – 10 kg
Regulatory	CE (Class A), FCC (Class A), UL Listed		
Input Voltage	120/240 VAC auto-sensing		
Power Supplies	Single	Single (Dual Optional)	Single
Power & Heat	160 Watts/540 BTU/h (Max) 110 Watts/370 BTU/h (Typical)	240 Watts/790 BTU/h (Max) 140 Watts/470 BTU/h (Typical)	150 Watts/500 BTU/h (Max) 110 Watts/370 BTU/h (Typical)
Operating Temperature	40° – 95°F (4.5° – 35°C)		
Server Revision	G1	G1	H1
Compatible Client Operating System	Windows 7, Vista, XP, Server 2003/2008 32-bit or 64-bit Linux (Ubuntu) Mac OS X		

All part numbers can be found in the product catalog at: <https://exacq.com/catalog/>
 Specifications subject to change. Visit www.exacq.com for the most current product specifications.



Exacq Technologies, Inc.
 11955 Exit Five Parkway
 Fishers, IN 46037 USA

Exacq Technologies Europe, Ltd.
 Business & Technology Centre
 Bessemer Drive
 Stevenage, Herts SG1 2DY, UK

+1.317.845.5710 USA
 +5255.56080817 Mexico
 +44.2087.505660 UK/Europe
 +852.8130.9275 Hong Kong

exacq
 Technologies
www.exacq.com

MegaDome® 2

H.264 All-in-One Motorized P-Iris Lens Day/Night IR Indoor/Outdoor Dome IP Cameras with Wide Dynamic Range (WDR) and STELLAR™ Models

Camera Models

1.2 Megapixel	1.3 Megapixel	1080p	1080p WDR	3 Megapixel	3 Megapixel WDR	5 Megapixel	10 Megapixel
AV1255PM-SH	AV1255DN-H	AV2255DN-H	AV2256DN	AV3255DN-H	AV3256DN	AV5255DN-H	AV10255PMIR-SH
AV1255PMIR-SH		AV2255AM-H	AV2256PM	AV3255AM-H	AV3256PM	AV5255AM-H	AV10255PMTIR-SH
		AV2255PMIR-SH	AV2256PMIR-S	AV3255PMIR-SH	AV3256PMIR-S	AV5255PMIR-SH	
		AV2255PMIR-SAH	AV2256PMTIR-S	AV3255PMTIR-SH	AV3256PMIR-SA	AV5255PMIR-SAH	
		AV2255PMTIR-SH			AV3256PMTIR-S	AV5255PMTIR-SH	

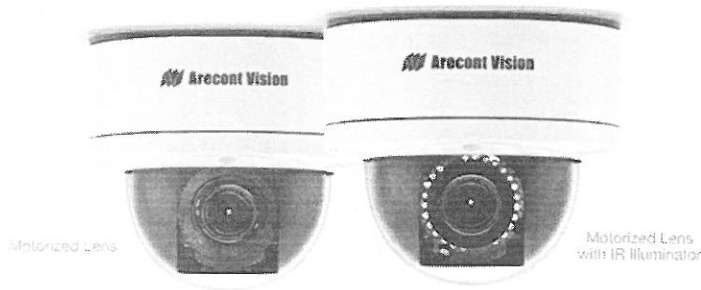

MegaDome® 2 multi-megapixel cameras provide ample resolution to zoom-in for details in live or recorded video. These indoor/outdoor all-in-one solutions integrate a 1.2, 1.3, 1080p, 3, 5 or 10-megapixel (MP) camera with fast frame rates and an IR corrected motorized wide angle or telephoto vari-focal lens into an IP66 environmental rated and IK-10 impact-resistant dome housing. Remote focus and remote zoom make MegaDome® 2 easy to install and manage. MegaDome® 2 cameras are also available in manual lens models.

Integrated Motorized Lens with Remote Focus and Zoom (AM/PM Version)

P-Iris Control for Best Depth of Field and Image Clarity (PM Models)

Wide Angle or Telephoto Lens Option

All-in-One Dome Solution

True Day/Night with IR Cut Filter

Impact / Weather Resistant IK-10 and IP66 Rated

Audio Input/Output (-A Models)

SDHC Card Slot (-S Models)

CorridorView™ with 90° Image Flip (-S Models)

10MP 80P
Dual Mode: 1080p/10MP on 10MP Models

STELLAR™
Low Light Technology on 1.2MP Models

Pixel Binning Mode on 3, 5, and 10MP Models

WDR
Wide Dynamic Range Available on Some 1080p and 3MP Models

IR LEDs (IR Models)

Heater (-H Models)

Casino Mode™
Maintains at Least 30fps on AV2255 Models

Dual Encoder H.264/MJPEG

Features:

- Remote Focus/Zoom Motorized Auto-Iris or P-Iris Lens (AM/PM Models)
- P-Iris Control to Get Best Depth of Field and Image Clarity (PM Models)
- Wide Angle or Telephoto Lens Options
- Optional True WDR up to 100dB at Full Resolution Available on Some 1080p and 3MP Models: See Clearly in Shaded and Bright Light Conditions Simultaneously
- STELLAR™ Low Light Technology Reduces Motion Blur, Noise and Storage Requirements, While Enhancing Contrast and Allowing Color Imaging in Near Complete Darkness on 1.2MP Models
- Heater and Optional Audio and IR LEDs (No Heater Required for WDR Models)
- SDHC Card Slot for Onboard Storage (-S Models)
- Casino Mode™ Guarantees Continuous 30fps Frame Rate Required by Gaming Industry Regulations (AV2255 Models)
- CorridorView™ Allows 90° Image Rotation for Better Coverage in Hallways and Corridors
- Binning Mode for Strong Low Light Performance on 3MP, 5MP and 10MP Resolutions
- True Day/Night Functionality with Mechanical IR Cut Filter and Optional IR LEDs
- Outdoor Rated IP66 and IK-10 Impact-Resistant Housing
- Total PoE Solution (No External Power Required for Heater and IR LEDs)
- PoE and Auxiliary Power: 12-48V DC/24V AC
- Easily Adjustable 3-Axis Gymbal
- Dual Encoder H.264/MJPEG
- Privacy Mask, Motion Detection, Flexible Cropping, Bit Rate Control, Multi-Streaming, Forensic Zooming and Non-Integer Scaling
- Fast Frame Rates
- PSIA Compliant
- User-Friendly Web Interface
- Reduced Overall System Cost
- Made in the USA

Model Specific Features

Model	Resolution	Frame Rate	Features		
AV1255	1.2MP	37fps	-	-	STELLAR™
	1.3MP	42fps	-	-	-
AV2255	1080p	30fps	-	Casino Mode™	-
AV2256	1080p	30fps	WDR	-	-
AV3255	3MP	21fps	-	-	Binning
AV3256	3MP	21fps	WDR	-	Binning
AV5255	5MP	14fps	-	-	Binning
AV10255	10MP	7fps	-	-	Binning

Other Features and Options

Option	Description
AM	Remote Focus/Zoom, Auto-Iris, Day/Night
PM	Wide Angle Lens w/ Remote Focus/Zoom, P-Iris, Day/Night
PMT	Telephoto Lens w/ Remote Focus/Zoom, P-Iris, Day/Night
DN	Manual Lens, Day/Night
IR	IR LEDs
-H	Heater (Non-WDR Models Only)
-A	Audio
-S	SDHC Card Slot, CorridorView™ w/ 90° Image Flip, Non-Integer Scaling

Camera Imaging Specifications

		AV1255		AV2255		AV2256		AV3255		AV3256		AV5255		AV10255	
Model															
Image Sensor (CMOS)		1.2MP		1.3MP**		1080p		1080p		3MP		3MP		10MP	
Optical Format		1/3"		1/2.7"		1/2.7"		1/3.2"		1/2.5"		1/3.2"		1/2.3"	
Pixel Pitch		3.75µm		3µm		3µm		2.2µm		2.2µm		2.2µm		1.67µm	
Minimum Illumination	Color (Day Mode)	0.02 Lux		0.1 Lux		0.1 Lux		0.3 Lux		0.3 Lux		0.3 Lux		0.42 Lux	
	Color Binning (Day Mode)	-		-		-		-		0.15 Lux		0.15 Lux		0.21 Lux	
	B/W (Night Mode)	0.002 Lux, 0 Lux, IR sensitive		0 Lux, IR sensitive		0 Lux, IR sensitive		0 Lux, IR sensitive		0 Lux, IR sensitive		0 Lux, IR sensitive		0 Lux, IR sensitive	
Full FOV Resolution		1280 H x 960 V		1280 H x 1024 V		1920 H x 1080 V		1920 H x 1080 V		2048 H x 1536 V		2048 H x 1536 V		3648 H x 2752 V	
1/4 Resolution		640 H x 480 V		640 H x 512 V		960 H x 540 V		960 H x 540 V		1024 H x 768 V		1024 H x 768 V		1824 H x 1376 V	
Scaling		-		-		See: Scaling Resolution Chart		See: Scaling Resolution Chart		See: Scaling Resolution Chart		See: Scaling Resolution Chart		See: Scaling Resolution Chart	
Dynamic Range		83.5dB		69dB		69dB		WDR up to 100dB		70.1dB		WDR up to 100dB		70.1dB	
Maximum SNR		54dB		45dB		45dB		49dB		45dB		49dB		57.2dB	
Frame Rates	At Max Resolution	37fps (1280x960)		42fps (1280x1024)		30fps (1920x1080)		30fps (1920x1080)		21fps (2048x1536)		21fps (2048x1536)		14fps (2592x1944)	
	Cropped	-		-		42fps (1280x1024)		41fps (1280x1024)		29fps (1920x1080) 41fps (1280x1024)		30fps (1920x1080) 31fps (1600x1200) 41fps (1280x1024)		21fps (2048x1536) 29fps (1920x1080) 41fps (1280x1024)	
	Binning Mode	-		-		-		-		46fps (1024x768) 64fps (960x540)		21fps (1024x768) 27fps (800x600) 31fps (960x540) 32fps (640x512)		34fps (1296x972) 46fps (1024x768) 64fps (960x540)	
Lens	Wide Angle Motorized (AM Models)	-		-		3-9mm, F1.2, RZ, RF, Auto-Iris, H-FOV = 115°-37°		-		3.6-9mm, F1.8, RZ, RF, Auto-Iris, H-FOV = 76°-28°		-		3.6-9mm, F1.8, RZ, RF, Auto-Iris, H-FOV = 96°-36°	
	Wide Angle Motorized (PM/PMIR Models)	3-9mm, F1.2, RZ, RF, P-Iris, H-FOV = 92°-31°		-		2.8-8mm, F1.2, RZ, RF, P-Iris, H-FOV = 120°-44°		3-9mm, F1.2, RZ, RF, P-Iris, H-FOV = 82°-27°		2.8-8mm, F1.2, RZ, RF, P-Iris, H-FOV = 94°-34°		3-9mm, F1.2, RZ, RF, P-Iris, H-FOV = 87°-29°		3-8mm, F1.4, RZ, RF, P-Iris, H-FOV = 113°-43°	
	Telephoto Motorized (PMTIR Models)	-		-		8-22mm, 1/2.7", F1.6, RZ, RF, P-Iris, Telephoto, H-FOV = 42°-16°		8-22mm, 1/2.7", F1.6, RZ, RF, P-Iris, Telephoto, H-FOV = 30°-12°		8-22mm, 1/2.7", F1.6, RZ, RF, P-Iris, Telephoto, H-FOV = 29°-12°		8-22mm, 1/2.7", F1.6, RZ, RF, P-Iris, Telephoto, H-FOV = 32°-12°		9-22mm, 1/2.5", F2.0, RZ, RF, P-Iris, Telephoto, H-FOV = 38°-16°	
	Manual Lens (DN Models)	-		3.4-10.5mm, 1/2.5", F1.6, H-FOV = 62°-24°		3.4-10.5mm, 1/2.5", F1.6, H-FOV = 93°-36°		3.4-10.5mm, 1/2.5", F1.6, H-FOV = 68°-26°		3.4-10.5mm, 1/2.5", F1.6, H-FOV = 73°-28°		3.4-10.5mm, 1/2.5", F1.6, H-FOV = 72°-28°		3.4-10.5mm, 1/2.5", F1.6, H-FOV = 92°-36°	

STELLAR™ Model ** Effective

Scaling Resolution Chart

Scaled Resolution	H	V	Pixel Count
720p	1280	720	921600
XVGA	1024	768	786432
DVGA (16:9)	1136	640	727040
DVGA (3:2)	960	640	614400
SVGA	800	600	480000
D1 (PAL)	720	576	414720
4CIF (PAL)	704	576	405504
D1 (NTSC)	720	480	345600
4CIF (NTSC)	704	480	337920
VGA	640	480	307200
2CIF (PAL)	704	288	202752
HVGA (4:3)	480	360	172800
2CIF (NTSC)	704	240	168960
HVGA (8:3)	640	240	153600
HVGA (3:2)	480	320	153600
HVGA (16:9)	480	272	130560
CIF (PAL)	352	288	101376
CIF (NTSC)	352	240	84480
QVGA (SIF)	320	240	76800
QCIF (PAL)	176	144	25344
QCIF (NTSC)	176	120	21120
SQCIF	128	96	12288

Data Transmission	Compression Type	H.264 (MPEG-4, Part 10)/Motion JPEG 21 levels of quality
	Transmission Protocols	RTSP, RTP/TCP, RTP/UDP, HTTP, DHCP, TFTP 100Base-T Ethernet Network Interface
	Multi-Streaming	8 non-identical streams

Programmability	Remote focus, remote zoom and auto-iris or P-iris (AM or PM models) Motion detection and privacy mask with up to 1024 detection zones Non-integer scaling down to 128x96 Auto adjustment between WDR and LDR modes (WDR models Only) Programmable shutter speed to help control motion blur Pixel Binning Mode (3, 5 and 10MP) Casino Mode™ maintains 30fps (AV2255 model) Flexible Cropping (resolution windowing down to 1x1 pixel for JPEG and 2x2 pixels for H.264) Low light noise filter control Bit rate and bandwidth limitation control Backlight compensation and multi-matrix white balance 50/60Hz selectable flicker control Electronic pan, tilt, zoom (PTZ) 180° image flip or CorridorView™ (90°, 180° and 270° image rotation) on -S models Programmable resolution, brightness, saturation, gamma, sharpness, tint
------------------------	--

Compliance	Industry Standard	ONVIF Profile S and PSIA Conformant
	Listings	UL (CB)
	FCC Compliance	47 CFR 15 Class A
	Environmental	RoHS, REACH, WEEE
	Markings	(CE) EN55022 Class A, EN55024, EN61000-3-2, EN61000-3-3, EN60950-1
	Mechanical	IK-10 (EN62262), IP66 (EN60529)

Environmental	Operating temperature	-40°C (-40°F) to +50°C (122°F) w/ Heater or WDR Models w/o Heater
	Humidity	0% to 90% (non-condensing)
	Stable image temperature	0°C (32°F) to +50°C (122°F)
	Storage temperature	-40°C (-40°F) to +60°C (140°F)

Electrical	Alarm Input/Output	General purpose opto-coupled
	Power Over Ethernet	PoE 802.3af, Class 2
	Auxiliary Power	12-48V DC, 24V AC

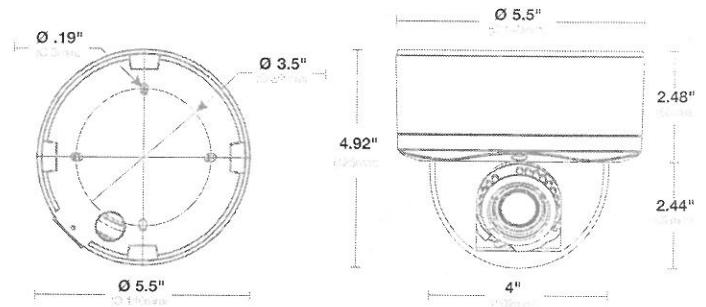

Accessories	SV-JBA	Junction Box Adapter
	SV-EBA	Electrical Box Adapter
	MD-PMA	Pole Mount Adapter
	MD-CRMA	Corner Mount Adapter
	MD-WMT2	Wall Mount (Fit 1.5" NPT)
	MD-CMT	Ceiling Mount (Fit 1.5" NPT)
	MD-FMA	Flush Mount Adapter
MD-CAP	Wall Mount Cap Only w/ 1.5" NPT	

Max Power Consumption (Watts DC Power)

		DN	DN-H	AM-H	PM	PM-SH	PMIR-S	PMIR-SH	PMTIR-S	PMTIR-SH
AV1255	1.2MP	-	-	-	-	9.0	-	11.7	-	-
	1.3MP	-	10.2	-	-	-	-	-	-	-
AV2255	-	10.2	10.2	-	-	-	12.1	-	14.5	
AV2256/3256	6.6	-	-	11.3	-	12.7	-	14.2	-	
AV3255/5255	-	9.9	9.9	-	-	-	12.1	-	14.4	
AV10255	-	-	-	-	-	-	13.0	-	13.8	

IR Illuminator (IR Models)	AMIR/PMIR	24 pcs 850nm LEDs / 50ft (15m) IR distance (max) / 40° IR angle
	PMTIR	24 pcs 850nm LEDs / 120ft (36m) IR distance (max) / 30° IR angle
Total PoE Solution (No external power requirement)		

Audio Electrical (-A and -AH Models)	Streaming	Two-way
	Compression	G.711 PCM 8 kHz
	Input/output	Microphone in or line in / line output

Heater Electrical (-H and -AH Models)	Power Consumption	2.28 W Max
	Switch	On: 4°C (32.9°F), Off: 6.5°C (43.7°F)
Total PoE Solution (No external power requirement)		

Mechanical		Die-cast aluminum chassis with 4" polycarbonate dome bubble	
	Casing	IP66 weather proof standard	
		Impact resistant, IK-10 rated	
	Gimbal	Easily adjustable 3-axis camera gimbal w/360° pan, 90° tilt and 360° z-axis	
	Total Unit Dimensions	Unit	Ø 5.5" (140mm) x 4.9" H (125mm)
		Packaged	8" W (203mm) x 7.5" L (190mm) x 6" H (152mm)
	Weight	Unit	2.25 lbs (1.02kg)
		Packaged	2.85 lbs (1.27kg)
	On Board Storage	SDHC slot up to 32GB (Card not included)	

ADDENDUM ACKNOWLEDGEMENT FORM
SOLICITATION NO.: BVH150000003

Instructions: Please acknowledge receipt of all addenda issued with this solicitation by completing this addendum acknowledgment form. Check the box next to each addendum received and sign below. Failure to acknowledge addenda may result in bid disqualification.

Acknowledgment: I hereby acknowledge receipt of the following addenda and have made the necessary revisions to my proposal, plans and/or specification, etc.

Addendum Numbers Received:

(Check the box next to each addendum received)

- | | |
|--|--|
| <input checked="" type="checkbox"/> Addendum No. 1 | <input type="checkbox"/> Addendum No. 6 |
| <input checked="" type="checkbox"/> Addendum No. 2 | <input type="checkbox"/> Addendum No. 7 |
| <input checked="" type="checkbox"/> Addendum No. 3 | <input type="checkbox"/> Addendum No. 8 |
| <input checked="" type="checkbox"/> Addendum No. 4 | <input type="checkbox"/> Addendum No. 9 |
| <input type="checkbox"/> Addendum No. 5 | <input type="checkbox"/> Addendum No. 10 |

I understand that failure to confirm the receipt of addenda may be cause for rejection of this bid. I further understand that any verbal representation made or assumed to be made during any oral discussion held between Vendor's representatives and any state personnel is not binding. Only the information issued in writing and added to the specifications by an official addendum is binding.

MOUNTAIN STATE BUILDING AUTOMATION, LLC

Company

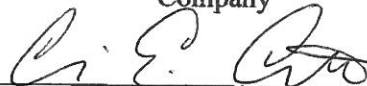

Authorized Signature

11-20-14

Date

NOTE: This addendum acknowledgment should be submitted with the bid to expedite document processing.

Revised 6/8/2012

CERTIFICATION AND SIGNATURE PAGE

By signing below, or submitting documentation through wvOASIS, I certify that I have reviewed this Solicitation in its entirety; understand the requirements, terms and conditions, and other information contained herein; that I am submitting this bid, offer or proposal for review and consideration; that I am authorized by the vendor to execute and submit this bid, offer, or proposal, or any documents related thereto on vendor's behalf; that I am authorized to bind the vendor in a contractual relationship; and that to the best of my knowledge, the vendor has properly registered with any State agency that may require registration.

MOUNTAIN STATE BUILDING AUTOMATION, LLC
(Company)

C. E. Carter CRAIG CARTER, VICE PRESIDENT
(Authorized Signature) (Representative Name, Title)

304 984-0415 304 984-0124
(Phone Number) (Fax Number) (Date)

ADDITIONAL TERMS AND CONDITIONS (Construction Contracts Only)

1. **CONTRACTOR'S LICENSE:** West Virginia Code § 21-11-2 requires that all persons desiring to perform contracting work in this state be licensed. The West Virginia Contractors Licensing Board is empowered to issue the contractor's license. Applications for a contractor's license may be made by contacting the West Virginia Division of Labor. West Virginia Code § 21-11-11 requires any prospective Vendor to include the contractor's license number on its bid. Failure to include a contractor's license number on the bid shall result in Vendor's bid being disqualified. Vendors should include a contractor's license number in the space provided below.

Contractor's Name: MOUNTAIN STATE BUILDING AUTOMATION, LLC

Contractor's License No. WV044802

The apparent successful Vendor must furnish a copy of its contractor's license prior to the issuance of a Award Document.

2. **DRUG-FREE WORKPLACE AFFIDAVIT:** W. Va. Code § 21-1D-5 provides that any solicitation for a public improvement contract requires each Vendor that submits a bid for the work to submit at the same time an affidavit that the Vendor has a written plan for a drug-free workplace policy. To comply with this law, Vendor must either complete the enclosed drug-free workplace affidavit and submit the same with its bid or complete a similar affidavit that fulfills all of the requirements of the applicable code. Failure to submit the signed and notarized drug-free workplace affidavit or a similar affidavit that fully complies with the requirements of the applicable code, with the bid shall result in disqualification of Vendor's bid. Pursuant to W. Va. Code 21-1D-2(b) and (k), this provision does not apply to public improvement contracts the value of which is \$100,000 or less or temporary or emergency repairs.
 - 2.1. **DRUG-FREE WORKPLACE POLICY:** Pursuant to W. Va. Code § 21-1D-4, Vendor and its subcontractors must implement and maintain a written drug-free workplace policy that complies with said article. The awarding public authority shall cancel this contract if: (1) Vendor fails to implement and maintain a written drug-free workplace policy described in the preceding paragraph, (2) Vendor fails to provide information regarding implementation of its drug-free workplace policy at the request of the public authority; or (3) Vendor provides to the public authority false information regarding the contractor's drug-free workplace policy. Pursuant to W. Va. Code 21-1D-2(b) and (k), this provision does not apply to public improvement contracts the value of which is \$100,000 or less or temporary or emergency repairs.
3. **DRUG FREE WORKPLACE REPORT:** Pursuant to W. Va. Code § 21-1D-7b, no less than once per year, or upon completion of the project, every contractor shall provide a certified report to the public authority which let the contract. For contracts over \$25,000, the

BID BOND

KNOW ALL MEN BY THESE PRESENTS, That we, the undersigned, Mountain State Building Automation, LLC
of Sissonville, WV, as Principal, and The Cincinnati Insurance Company
of Cincinnati, OH, a corporation organized and existing under the laws of the State of
OH with its principal office in the City of Cincinnati, as Surety, are held and firmly bound unto the State
of West Virginia, as Obligee, in the penal sum of Five Percent of Amount Bid (\$ 5%) for the payment of which,
well and truly to be made, we jointly and severally bind ourselves, our heirs, administrators, executors, successors and assigns.

The Condition of the above obligation is such that whereas the Principal has submitted to the Purchasing Section of the
Department of Administration a certain bid or proposal, attached hereto and made a part hereof, to enter into a contract in writing for
BVH1500000003 megapixel camera security system - According to Plans & Specifications

NOW THEREFORE,

- (a) If said bid shall be rejected, or
- (b) If said bid shall be accepted and the Principal shall enter into a contract in accordance with the bid or proposal attached hereto and shall furnish any other bonds and insurance required by the bid or proposal, and shall in all other respects perform the agreement created by the acceptance of said bid, then this obligation shall be null and void, otherwise this obligation shall remain in full force and effect. It is expressly understood and agreed that the liability of the Surety for any and all claims hereunder shall, in no event, exceed the penal amount of this obligation as herein stated.

The Surety, for the value received, hereby stipulates and agrees that the obligations of said Surety and its bond shall be in no way impaired or affected by any extension of the time within which the Obligee may accept such bid, and said Surety does hereby waive notice of any such extension.

IN WITNESS WHEREOF, Principal and Surety have hereunto set their hands and seals, and such of them as are corporations have caused their corporate seals to be affixed hereunto and these presents to be signed by their proper officers, this
13th day of November, 2014.

Principal Corporate Seal

Mountain State Building Automation, LLC
(Name of Principal)
By Paul R Burdette
(Must be President or Vice President)
Paul R Burdette Managing Member
(Title)

Surety Corporate Seal

The Cincinnati Insurance Company
(Name of Surety)
By: Patricia A. Moye
Patricia A. Moye, WV Resident Agent Attorney-in-Fact

THE CINCINNATI INSURANCE COMPANY

Fairfield, Ohio

POWER OF ATTORNEY

KNOW ALL MEN BY THESE PRESENTS: That THE CINCINNATI INSURANCE COMPANY, a corporation organized under the laws of the State of Ohio, and having its principal office in the City of Fairfield, Ohio, does hereby constitute and appoint

Allan L. McVey; Gregory T. Gordon; Patricia A. Moye and/or Kimberly Wilkinson

of Charleston, West Virginia its true and lawful Attorney(s)-in-Fact to sign, execute, seal and deliver on its behalf as Surety, and as its act and deed, any and all bonds, policies, undertakings, or other like instruments, as follows:

Any such obligations in the United States, up to Fifty Million and No/100 Dollars (\$50,000,000.00).

This appointment is made under and by authority of the following resolution passed by the Board of Directors of said Company at a meeting held in the principal office of the Company, a quorum being present and voting, on the 6th day of December, 1958, which resolution is still in effect:

"RESOLVED, that the President or any Vice President be hereby authorized, and empowered to appoint Attorneys-in-Fact of the Company to execute any and all bonds, policies, undertakings, or other like instruments on behalf of the Corporation, and may authorize any officer or any such Attorney-in-Fact to affix the corporate seal; and may with or without cause modify or revoke any such appointment or authority. Any such writings so executed by such Attorneys-in-Fact shall be binding upon the Company as if they had been duly executed and acknowledged by the regularly elected officers of the Company."

This Power of Attorney is signed and sealed by facsimile under and by the authority of the following Resolution adopted by the Board of Directors of the Company at a meeting duly called and held on the 7th day of December, 1973.

"RESOLVED, that the signature of the President or a Vice President and the seal of the Company may be affixed by facsimile on any power of attorney granted, and the signature of the Secretary or Assistant Secretary and the seal of the Company may be affixed by facsimile to any certificate of any such power and any such power of certificate bearing such facsimile signature and seal shall be valid and binding on the Company. Any such power so executed and sealed and certified by certificate so executed and sealed shall, with respect to any bond or undertaking to which it is attached, continue to be valid and binding on the Company."

IN WITNESS WHEREOF, THE CINCINNATI INSURANCE COMPANY has caused these presents to be sealed with its corporate seal, duly attested by its Vice President this 10th day of May, 2012.



THE CINCINNATI INSURANCE COMPANY

Signature of Stephen A. Justice

Vice President

STATE OF OHIO) ss:
COUNTY OF BUTLER)

On this 10th day of May, 2012, before me came the above-named Vice President of THE CINCINNATI INSURANCE COMPANY, to me personally known to be the officer described herein, and acknowledged that the seal affixed to the preceding instrument is the corporate seal of said Company and the corporate seal and the signature of the officer were duly affixed and subscribed to said instrument by the authority and direction of said corporation.



Signature of Mark J. Huller

MARK J. HULLER, Attorney at Law
NOTARY PUBLIC - STATE OF OHIO
My commission has no expiration date. Section 147.03 O.R.C.

I, the undersigned Secretary or Assistant Secretary of THE CINCINNATI INSURANCE COMPANY, hereby certify that the above is a true and correct copy of the Original Power of Attorney issued by said Company, and do hereby further certify that the said Power of Attorney is still in full force and effect.

GIVEN under my hand and seal of said Company at Fairfield, Ohio, this 13th day of November 2014



Signature of Scott R. Bobb

Assistant Secretary



State of West Virginia
DRUG FREE WORKPLACE CONFORMANCE AFFIDAVIT
West Virginia Code §21-1D-5

STATE OF WEST VIRGINIA,

COUNTY OF KANAWHA, TO-WIT:

I, CRAIG CARTER, after being first duly sworn, depose and state as follows:

1. I am an employee of MOUNTAIN STATE BUILDING AUTOMATION, LLC, and,
(Company Name)

2. I do hereby attest that MOUNTAIN STATE BUILDING AUTOMATION, LLC
(Company Name)

maintains a valid written drug free workplace policy and that such policy is in compliance with **West Virginia Code §21-1D**.

The above statements are sworn to under the penalty of perjury.

By: C. E. Carter

Title: VICE PRESIDENT

Company Name: MOUNTAIN STATE BUILDING AUTOMATION, LLC

Date: 11/20/14

Taken, subscribed and sworn to before me this 20th day of November, 2014.

By Commission expires Jan. 16 2022

(Seal)

Jana Wood
(Notary Public)

THIS AFFIDAVIT MUST BE SUBMITTED WITH THE BID IN ORDER TO COMPLY WITH WV CODE PROVISIONS. FAILURE TO INCLUDE THE AFFIDAVIT WITH THE BID SHALL RESULT IN DISQUALIFICATION OF THE BID.

RFQ No. Bv4 150000003

STATE OF WEST VIRGINIA
Purchasing Division

PURCHASING AFFIDAVIT

MANDATE: Under W. Va. Code §5A-3-10a, no contract or renewal of any contract may be awarded by the state or any of its political subdivisions to any vendor or prospective vendor when the vendor or prospective vendor or a related party to the vendor or prospective vendor is a debtor and: (1) the debt owed is an amount greater than one thousand dollars in the aggregate; or (2) the debtor is in employer default.

EXCEPTION: The prohibition listed above does not apply where a vendor has contested any tax administered pursuant to chapter eleven of the W. Va. Code, workers' compensation premium, permit fee or environmental fee or assessment and the matter has not become final or where the vendor has entered into a payment plan or agreement and the vendor is not in default of any of the provisions of such plan or agreement.

DEFINITIONS:

"Debt" means any assessment, premium, penalty, fine, tax or other amount of money owed to the state or any of its political subdivisions because of a judgment, fine, permit violation, license assessment, defaulted workers' compensation premium, penalty or other assessment presently delinquent or due and required to be paid to the state or any of its political subdivisions, including any interest or additional penalties accrued thereon.

"Employer default" means having an outstanding balance or liability to the old fund or to the uninsured employers' fund or being in policy default, as defined in W. Va. Code § 23-2c-2, failure to maintain mandatory workers' compensation coverage, or failure to fully meet its obligations as a workers' compensation self-insured employer. An employer is not in employer default if it has entered into a repayment agreement with the Insurance Commissioner and remains in compliance with the obligations under the repayment agreement.

"Related party" means a party, whether an individual, corporation, partnership, association, limited liability company or any other form or business association or other entity whatsoever, related to any vendor by blood, marriage, ownership or contract through which the party has a relationship of ownership or other interest with the vendor so that the party will actually or by effect receive or control a portion of the benefit, profit or other consideration from performance of a vendor contract with the party receiving an amount that meets or exceed five percent of the total contract amount.

AFFIRMATION: By signing this form, the vendor's authorized signer affirms and acknowledges under penalty of law for false swearing (W. Va. Code §61-5-3) that neither vendor nor any related party owe a debt as defined above and that neither vendor nor any related party are in employer default as defined above, unless the debt or employer default is permitted under the exception above.

WITNESS THE FOLLOWING SIGNATURE:

Vendor's Name: MOUNTAIN STATE BUILDING AUTOMATION, LLC

Authorized Signature: [Signature] Date: 11/20/14

State of WV

County of Kanawha, to-wit:

Taken, subscribed, and sworn to before me this 20th day of November, 2014

My Commission expires Jan. 16, 2022.

AFFIX SEAL HERE NOTARY PUBLIC



[Signature]
Purchasing Affidavit (Revised 07/01/2012)