

# CAPITOL BUSINESS INTERIORS

WV Division of Rehabilitation Bid  
May 14, 2014

The following discrepancies have been noted on the proposed bid. This bid followed the written specifications.

## Room #1 (Jeff & Petia)

1. There are no written specifications on chairs, but there are 2 chairs shown on the drawing at the 18" x 48" table. This bid does not include chairs.

## Room #8 (Copier/Printer)

1. Per addendum 3; 3.1.5.1 to include 1; 24"W Flip door unit while the drawing shows 2. This bid includes 1, 24" flip door unit.
2. The written specifications call for 2; 30"W flip door units while the drawing shows 4. This bid includes 2 flip door units.
3. Our equivalent to 3.1.5.4 & 3.1.5.5 is reversed. 2H metal storage cabinet on top, lateral file on bottom with a laminate top.

Contract Manager: Amanda Dickens  
Telephone Number: 304-346-3342  
Fax Number: 304-346-3350  
Email: [adickens@champion-industries.com](mailto:adickens@champion-industries.com)

Sincerely,  
Amanda Dickens

05/14/14 12:28:25PM  
West Virginia Purchasing Division



State of West Virginia  
 Department of Administration  
 Purchasing Division  
 2019 Washington Street East  
 Post Office Box 50130  
 Charleston, WV 25305-0130

**Solicitation**

|           |
|-----------|
| NUMBER    |
| DRS140335 |

|      |
|------|
| PAGE |
| 1    |

|  |
|--|
| ADDRESS CORRESPONDENCE TO ATTENTION OF |
| EVELYN MELTON<br>304-558-7023          |

RFQ COPY  
 TYPE NAME/ADDRESS HERE

VENDOR

DIV OF REHABILITATION SERVICES  
 JOBSITE  
 SEE SPECIFICATIONS

SHIP TO

|              |
|--------------|
| DATE PRINTED |
| 05/02/2014   |

BID OPENING DATE: 05/14/2014 BID OPENING TIME 1:30PM

| LINE | QUANTITY | UOP | CAT. NO. | ITEM NUMBER  | UNIT PRICE | AMOUNT |
|------|----------|-----|----------|--|------------|--------|
|      |          |     |          | ADDENDUM NO. 4                                       |            |        |
|      |          |     |          | ADDENDUM ISSUED;                                     |            |        |
|      |          |     |          | 1. TO MOVE THE BID OPENING DATE:                     |            |        |
|      |          |     |          | FROM: MAY 13, 2014 @ 1:30 P.M.                       |            |        |
|      |          |     |          | TO: MAY 14, 2014 @ 1:30 P.M.                         |            |        |
|      |          |     |          | 2. TO PROVIDE ADDENDUM ACKNOWLEDGMENT. THIS DOCUMENT |            |        |
|      |          |     |          | SHOULD BE SIGNED AND RETURNED WITH YOUR BID.         |            |        |
|      |          |     |          | FAILURE TO SIGN AND RETURN MAY RESULT IN THE         |            |        |
|      |          |     |          | DISQUALIFICATION OF YOUR BID.                        |            |        |
|      |          |     |          | END OF ADDENDUM NO. 4                                |            |        |
| 0001 | 1        | LS  |          | 425-94   |            |        |
|      |          |     |          | LABOR, MATERIALS AND EQUIPMENT - MODULAR FURNITURE   |            |        |
|      |          |     |          | FOR THE PROGRAM DEVELOPMENT OFFICE                   |            |        |
|      |          |     |          | ***** THIS IS THE END OF RFQ DRS140335 ***** TOTAL:  |            |        |

|                                    |                           |                                   |
|------------------------------------|---------------------------|-----------------------------------|
| SIGNATURE<br><i>Amanda Dickens</i> | TELEPHONE<br>304-340-3342 | DATE<br>5/14/14                   |
| TITLE<br>Sales! Design             | FEIN<br>55-0422766        | ADDRESS CHANGES TO BE NOTED ABOVE |

WHEN RESPONDING TO SOLICITATION, INSERT NAME AND ADDRESS IN SPACE ABOVE LABELED 'VENDOR'



State of West Virginia  
 Department of Administration  
 Purchasing Division  
 2019 Washington Street East  
 Post Office Box 50130  
 Charleston, WV 25305-0130

**Solicitation**

|           |
|-----------|
| NUMBER    |
| DRS140335 |

|      |
|------|
| PAGE |
| 1    |

|   |
|---|
| ADDRESS CORRESPONDENCE TO ATTENTION OF: |
| EVELYN MELTON                           |
| 304-558-7023                            |

RFQ COPY  
 TYPE NAME/ADDRESS HERE

V  
E  
N  
D  
O  
R

S  
H  
I  
P  
T  
O

DIV OF REHABILITATION SERVICES  
 JOBSITE  
 SEE SPECIFICATIONS

|              |
|--------------|
| DATE PRINTED |
| 04/25/2014   |

BID OPENING DATE: 05/13/2014 BID OPENING TIME 1:30PM

| LINE | QUANTITY | UOP | CAT. NO. | ITEM NUMBER  | UNIT PRICE | AMOUNT |
|------|----------|-----|----------|--|------------|--------|
|      |          |     |          | ADDENDUM NO. 3   |            |        |
|      |          |     |          | 1. ADDENDUM IS ISSUED TO PROVIDE RESPONSES TO VENDORS' QUESTIONS AND TO PROVIDE CLARIFICATIONS TO THE SPECIFICATIONS.  |            |        |
|      |          |     |          | 2. TO PROVIDE ADDENDUM ACKNOWLEDGMENT. THIS DOCUMENT SHOULD BE SIGNED AND RETURNED WITH YOUR BID. FAILURE TO SIGN AND RETURN MAY RESULT IN THE DISQUALIFICATION OF YOUR BID. |            |        |
|      |          |     |          | END OF ADDENDUM NO. 3  |            |        |
| 0001 | 1        | LS  |          | 425-94   |            |        |
|      |          |     |          | LABOR, MATERIALS AND EQUIPMENT - MODULAR FURNITURE   |            |        |
|      |          |     |          | FOR THE PROGRAM DEVELOPMENT OFFICE   |            |        |
|      |          |     |          | ***** THIS IS THE END OF RFQ DRS140335 ***** TOTAL:  |            |        |

|                                    |                           |                                   |
|------------------------------------|---------------------------|-----------------------------------|
| SIGNATURE<br><i>Amanda Dickens</i> | TELEPHONE<br>304-346-3342 | DATE<br>5/14/14                   |
| TITLE<br><i>Sales &amp; Design</i> | FEIN<br>55-04227166       | ADDRESS CHANGES TO BE NOTED ABOVE |

WHEN RESPONDING TO SOLICITATION, INSERT NAME AND ADDRESS IN SPACE ABOVE LABELED 'VENDOR'



State of West Virginia  
 Department of Administration  
 Purchasing Division  
 2019 Washington Street East  
 Post Office Box 50130  
 Charleston, WV 25305-0130

**Solicitation**

|           |
|-----------|
| NUMBER    |
| DRS140335 |

|      |
|------|
| PAGE |
| 1    |

|   |
|---|
| ADDRESS CORRESPONDENCE TO ATTENTION OF: |
| EVELYN MELTON<br>304-558-7023           |

RFQ COPY  
 TYPE NAME/ADDRESS HERE

V  
E  
N  
D  
O  
R

DIV OF REHABILITATION SERVICES  
 JOBSITE  
 SEE SPECIFICATIONS

S  
H  
I  
P  
T  
O

|              |
|--------------|
| DATE PRINTED |
| 04/22/2014   |

BID OPENING DATE: 05/13/2014 BID OPENING TIME 1:30PM

| LINE | QUANTITY | UOP | CAT. NO. | ITEM NUMBER  | UNIT PRICE | AMOUNT |
|------|----------|-----|----------|--|------------|--------|
|      |          |     |          | ADDENDUM NO. 2   |            |        |
|      |          |     |          | ADDENDUM ISSUED;   |            |        |
|      |          |     |          | 1. TO MOVE THE BID OPENING DATE:<br>FROM: MAY 7, 2014<br>TO: MAY 13, 2014  |            |        |
|      |          |     |          | 2. TO PROVIDE VENDORS A COPY OF THE MANDATORY PRE-BID SIGN-IN SHEETS.  |            |        |
|      |          |     |          | 3. TO PROVIDE ADDENDUM ACKNOWLEDGMENT. THIS DOCUMENT SHOULD BE SIGNED AND RETURNED WITH YOUR BID. FAILURE TO SIGN AND RETURN MAY RESULT IN THE DISQUALIFICATION OF YOUR BID. |            |        |
|      |          |     |          | END OF ADDENDUM NO. 2  |            |        |
| 0001 | 1        | LS  |          | 425-94   |            |        |
|      |          |     |          | LABOR, MATERIALS AND EQUIPMENT - MODULAR FURNITURE   |            |        |
|      |          |     |          | FOR THE PROGRAM DEVELOPMENT OFFICE   |            |        |

|                                    |                           |                                   |
|------------------------------------|---------------------------|-----------------------------------|
| SIGNATURE<br><i>Amanda Dinkens</i> | TELEPHONE<br>304-346-3342 | DATE<br>5/14/14                   |
| TITLE<br><i>Sales + Design</i>     | FEIN<br>55-04227660       | ADDRESS CHANGES TO BE NOTED ABOVE |

WHEN RESPONDING TO SOLICITATION, INSERT NAME AND ADDRESS IN SPACE ABOVE LABELED 'VENDOR'



State of West Virginia  
 Department of Administration  
 Purchasing Division  
 2019 Washington Street East  
 Post Office Box 50130  
 Charleston, WV 25305-0130

**Solicitation**

|           |
|-----------|
| NUMBER    |
| DRS140335 |

|      |
|------|
| PAGE |
| 1    |

|   |
|---|
| ADDRESS CORRESPONDENCE TO ATTENTION OF: |
| EVELYN MELTON<br>304-558-7023           |

VENDOR

RFQ COPY  
 TYPE NAME/ADDRESS HERE

SHIP TO

DIV OF REHABILITATION SERVICES  
 JOBSITE  
 SEE SPECIFICATIONS

|              |
|--------------|
| DATE PRINTED |
| 04/07/2014   |

BID OPENING DATE: 05/07/2014 BID OPENING TIME 1:30PM

| LINE  | QUANTITY | UOP | CAT. NO. | ITEM NUMBER  | UNIT PRICE | AMOUNT |
|---|----------|-----|----------|--|------------|--------|
|   |          |     |          | ADDENDUM NO. 1   |            |        |
|   |          |     |          | ADDENDUM ISSUED:   |            |        |
|   |          |     |          | 1. TO MOVE THE BID OPENING DATE;<br>FROM: MAY 6, 2014 @ 1:30 P.M.<br>TO: MAY 7, 2014 @ 1:30 P.M.   |            |        |
|   |          |     |          | 2. TO PROVIDE ADDENDUM ACKNOWLEDGMENT. THIS DOCUMENT SHOULD BE SIGNED AND RETURNED WITH YOUR BID. FAILURE TO SIGN AND RETURN MAY RESULT IN THE DISQUALIFICATION OF YOUR BID. |            |        |
|   |          |     |          | END OF ADDENDUM NO. 1  |            |        |
| 0001  | 1        | LS  | 425-94   | LABOR, MATERIALS AND EQUIPMENT - MODULAR FURNITURE<br><br>FOR THE PROGRAM DEVELOPMENT OFFICE   |            |        |
| ***** THIS IS THE END OF RFQ DRS140335 ***** TOTAL: |          |     |          |  |            |        |

|                                    |                           |                                   |
|------------------------------------|---------------------------|-----------------------------------|
| SIGNATURE<br><i>Amanda Dickers</i> | TELEPHONE<br>304-340-3342 | DATE<br>5/14/14                   |
| TITLE<br>Sales & Design            | FEIN<br>55-0422766        | ADDRESS CHANGES TO BE NOTED ABOVE |

WHEN RESPONDING TO SOLICITATION, INSERT NAME AND ADDRESS IN SPACE ABOVE LABELED 'VENDOR'



State of West Virginia  
 Department of Administration  
 Purchasing Division  
 2019 Washington Street East  
 Post Office Box 50130  
 Charleston, WV 25305-0130

**Solicitation**

|           |
|-----------|
| NUMBER    |
| DRS140335 |

|      |
|------|
| PAGE |
| 1    |

|   |
|---|
| ADDRESS CORRESPONDENCE TO ATTENTION OF: |
| EVELYN MELTON                           |
| 304-558-7023                            |

V  
E  
N  
D  
O  
R

RFQ COPY  
 TYPE NAME/ADDRESS HERE

S  
H  
I  
P  
T  
O

DIV OF REHABILITATION SERVICES  
 JOBSITE  
 SEE SPECIFICATIONS

|              |
|--------------|
| DATE PRINTED |
| 04/02/2014   |

BID OPENING DATE: 05/06/2014 BID OPENING TIME 1:30PM

| LINE   | QUANTITY | UOP | CAT. NO. | ITEM NUMBER | UNIT PRICE | AMOUNT             |
|--|----------|-----|----------|-------------|------------|--------------------|
| THE WEST VIRGINIA PURCHASING DIVISION IS SOLICITING BIDS ON BEHALF OF THE WEST VIRGINIA DIVISION OF REHABILITATION SERVICES, ADMINISTRATIVE SUPPORT SERVICES TO ESTABLISH A CONTRACT TO PROVIDE MODULAR FURNISHINGS FOR THE PROGRAM DEVELOPMENT OFFICES AT THE KANAWHA CITY, WV LOCATION PER THE ATTACHED SPECIFICATION AND INSTRUCTIONS TO BIDDERS. |          |     |          |             |            |                    |
| 0001   | 1        | LS  |          | 425-94      |            |                    |
| LABOR, MATERIALS AND EQUIPMENT - MODULAR FURNITURE   |          |     |          |             |            |                    |
| FOR THE PROGRAM DEVELOPMENT OFFICE   |          |     |          |             |            |                    |
| ***** THIS IS THE END OF RFQ DRS140335 ***** TOTAL:  |          |     |          |             |            | <u>\$20,827.17</u> |

|                                     |                           |                                   |
|-------------------------------------|---------------------------|-----------------------------------|
| SIGNATURE<br><i>Amanda Crickens</i> | TELEPHONE<br>304-340-3342 | DATE<br>5/14/14                   |
| TITLE<br>Sales & Design             | FEIN<br>55-04227660       | ADDRESS CHANGES TO BE NOTED ABOVE |

WHEN RESPONDING TO SOLICITATION, INSERT NAME AND ADDRESS IN SPACE ABOVE LABELED 'VENDOR'

REQUEST FOR QUOTATION  
DRS140335 MODULAR FURNITURE

---

**EXHIBIT A**

**PRICING PAGE**

**VENDOR TO COMPLETE:**

Line of Furniture Bid: Haworth, Indiana, Global total office, Thight Angle, Safco

Enclosed Pertinent Manufacturer Literature:  Yes  No

Attached detailed quote/list of components for each room:  Yes  No

| ROOM        | COST QUOTE          |
|-------------|---------------------|
| Room # 1    | \$ <u>8,102.23</u>  |
| Room # 3    | \$ <u>5,210.35</u>  |
| Room # 5    | \$ <u>5,391.61</u>  |
| Room #8     | \$ <u>2,122.98</u>  |
| GRAND TOTAL | \$ <u>20,827.17</u> |

Award shall be made to the lowest bid Grand Total meeting specifications.

Amanda Dickens 5/14/14  
Signature Date

Company Name: Capitol Business Interiors

Address: 711 Indiana Avenue Charleston, WV 25302

Phone: 304-340-3342 FAX: 304-340-3350

Email: adickens@champion-industries.com

# DIV. OF REHABILITATION SERVICES // *Bid Drawings*

4701 MACCORKLE AVENUE, SE  
CHARLESTON, WV 25304

5 | 14 | 2014

---

C A P I T O L B U S I N E S S I N T E R I O R S

711 INDIANA AVENUE. CHARLESTON, WV 25302

T. 304-346-3342 F. 304-346-3350



# Room #1

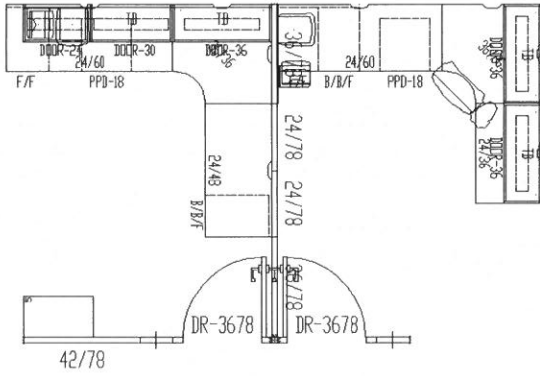

36 x 24 x 72  
WIRE  
SHELVING

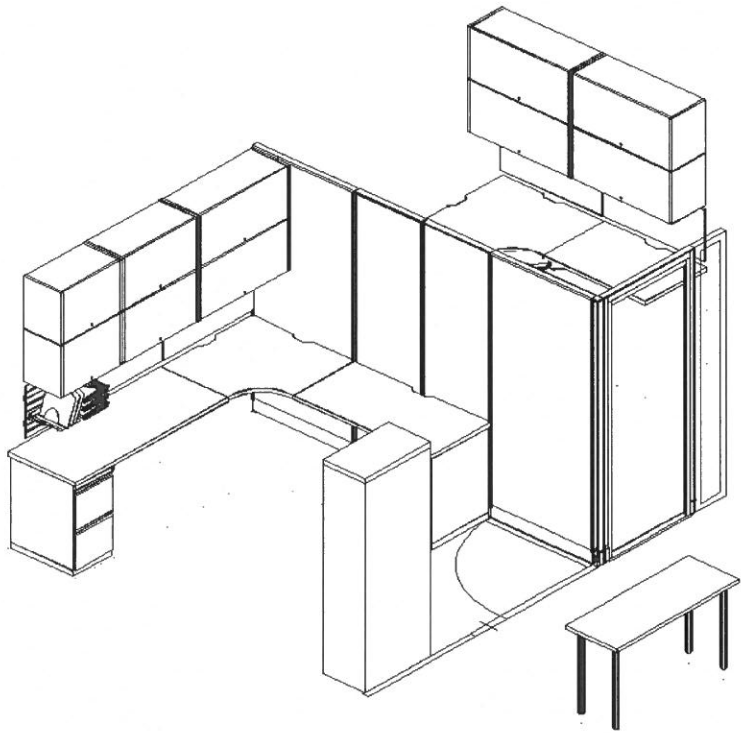

View 1

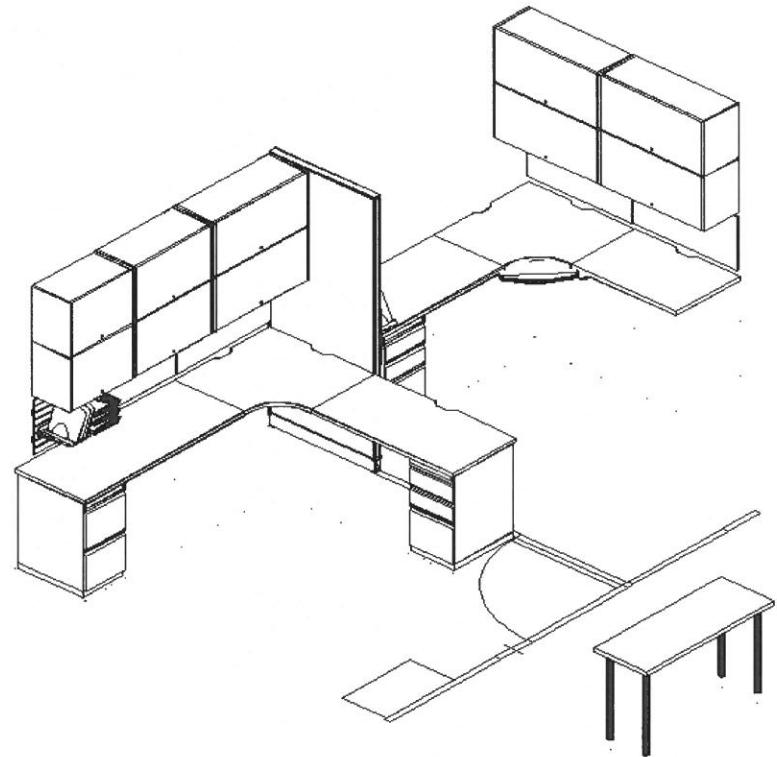

View 2

# Room #3

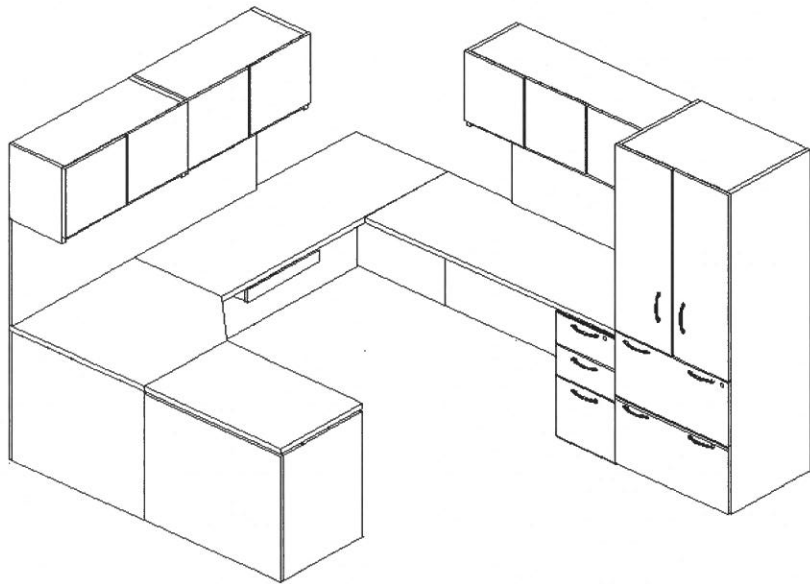
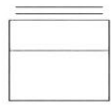
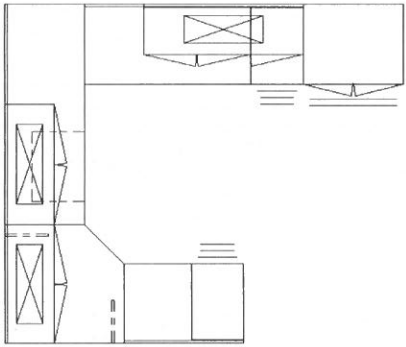

View 1

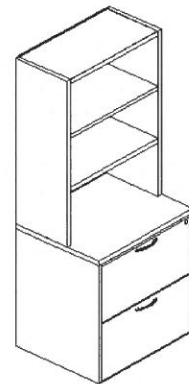
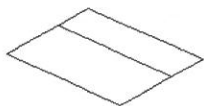

View 2

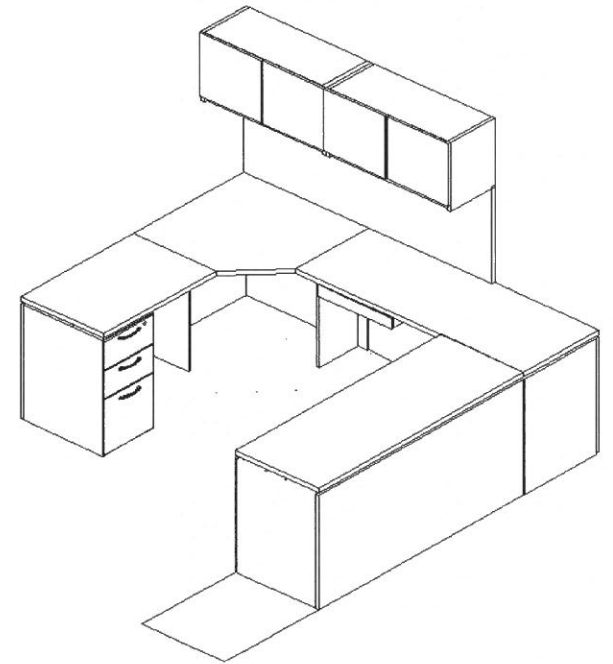

# Room #5

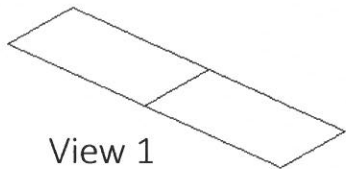
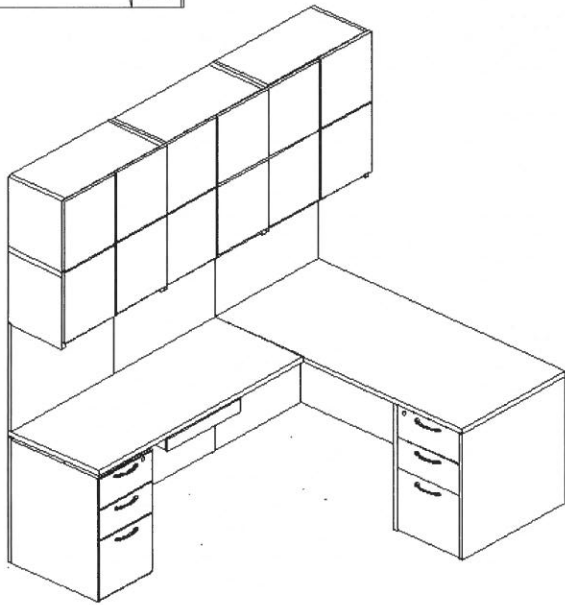
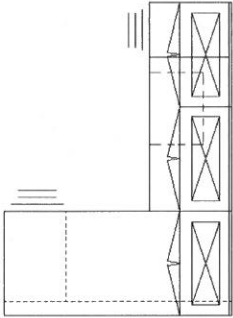
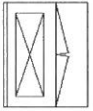
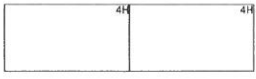

View 1

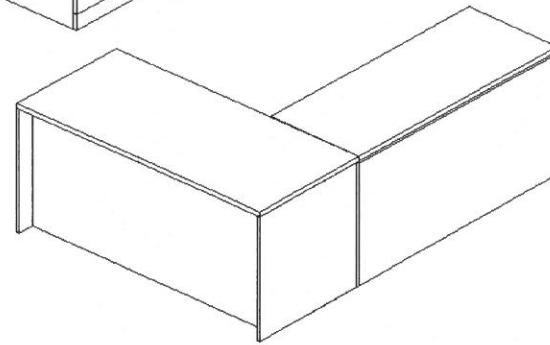
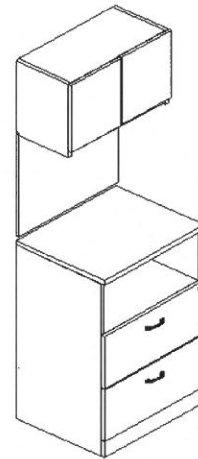
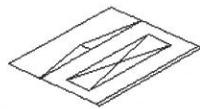



View 2

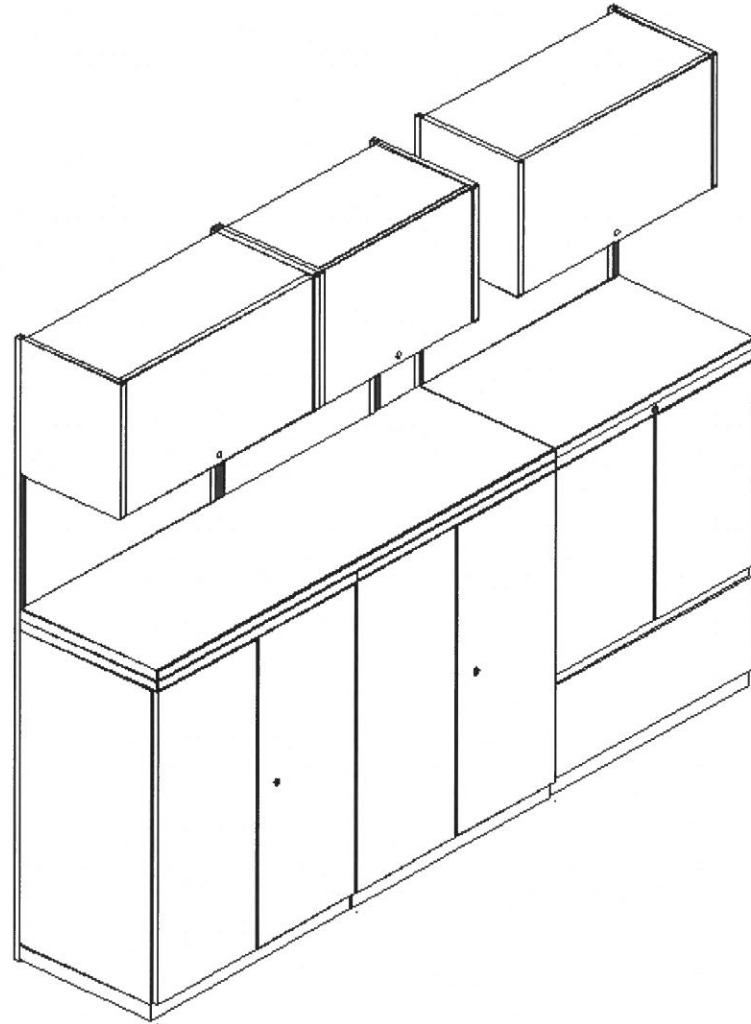
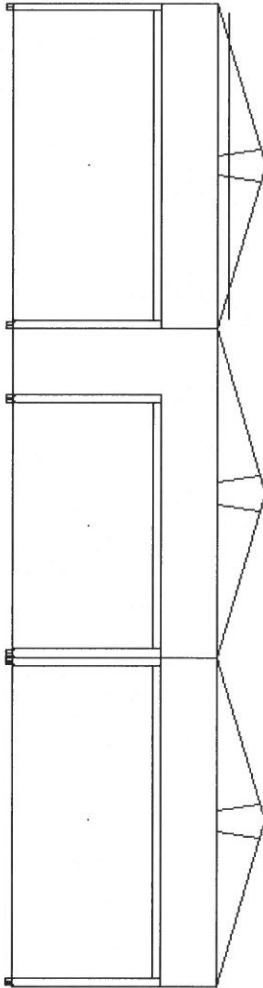

# Room #8





| Rec#Mfg | Qty   | Part Number | Part Description   | Cust\$  | EXT Cust\$ |
|---------|-------|-------------|--|---|------------|
|         |       | Tag 1       | Tag 3  |   |            |
|         |       | Tag 2       |  |   |            |
| 1       | GUS 1 | 25-500      | VERTICAL FILES-2500 Series-5 drawer.<br>25D x 15.15W x 64 1/4H | 218.06  | 218.06     |
|         | ✓     |             |  |   |            |
|         |       |             |  |    |            |
| 2       | HAI 1 | LSET-6      | HW,Lock Set, Keyed Alike,Lock Plug And<br>Key, Qty Of 6        | 0.00  | 0.00       |
|         | ✓     |             |  |   |            |
| 3       | HAI 1 | LSET-8      | HW,Lock Set, Keyed Alike,Lock Plug And<br>Key, Qty Of 8        | 0.00  | 0.00       |
|         | ✓     |             |  |   |            |
| 4       | HAW 6 | DTLT-2      | Letter Tray  | 10.02   | 60.12      |
|         | ✓     |             |  |   |            |
|         |       |             |  |  |            |





| Rec#Mfg | Qty   | Part Number<br>Tag 1<br>Tag 2 | Part Description<br>Tag 3                           | Cust\$ | EXT Cust\$  |
|---------|-------|-------------------------------|---|--------|---|
| 5       | HAW 2 | DTPR-3                        | Moxie Jump Stuff Paper Sorter                       | 27.22  | 54.44   |
|         | ✓     |                               |   |        |   |
|         |       |                               |   |        |    |
| 6       | HAW 2 | E2DS-3678-BHL                 | Single Mono Door W/Frame,Sq Top Cap,36In.W X 78In.H | 531.84 | 1063.68   |
|         | ✓     |                               |   |        |   |
|         |       |                               |   |        |   |
| 7       | HAW 2 | E2GN-178-B                    | Glazed Panel,Sq Top Cap,No-Power,12In.W x 80In.H    | 343.64 | 687.28  |
|         | ✓     | SPECIAL                       |   |        |   |
| 8       | HAW 2 | E2MN-278-BE                   | Mono Panel,Sq Top Cap,No-Power,24In.W X 80In.H      | 178.08 | 356.16  |
|         | ✓     |                               |   |        |   |
|         |       |                               |   |        |  |





| Rec#Mfg | Qty   | Part Number    | Part Description                                  | Cust\$  | EXT Cust\$ |
|---------|-------|----------------|---|---|------------|
|         |       | Tag 1<br>Tag 2 | Tag 3   |   |            |
| 9       | HAW 2 | E2MN-378-BE    | Mono Panel,Sq Top Cap,No-Power,36In.W<br>X 80In.H | 214.00  | 428.00     |
|         | ✓     |                |   |    |            |
| 10      | HAW 1 | E2MN-4278-B    | Mono Panel,Sq Top Cap,No-Power,42In.W<br>X 80In.H | 248.16  | 248.16     |
|         | ✓     |                |   |   |            |
| 11      | HAW 1 | E2PS-78        | 180Deg Finish Post,Painted,80In.H                 | 21.99   | 21.99      |
|         | ✓     |                |   |  |            |





| Rec#  | Mfg | Qty | Part Number | Part Description                                | Cust\$ | EXT Cust\$ |
|---|-----|-----|-------------|---|--------|------------|
|   |     |     | Tag 1       | Tag 3   |        |            |
|   |     |     | Tag 2       |   |        |            |
| 12  | HAW | 2   | FDRF-2      | UniGroup,Upper Storage,Flipper Door,24"W,Fabric | 118.76 | 237.52     |
|   |     | ✓   |             |   |        |            |
|    |     |     |             |   |        |            |
| 13  | HAW | 6   | FDRF-3      | UniGroup,Upper Storage,Flipper Door,36"W,Fabric | 129.89 | 779.34     |
|   |     | ✓   |             |   |        |            |
|  |     |     |             |   |        |            |
| 14  | HAW | 2   | FDRF-30     | UniGroup,Upper Storage,Flipper Door,30"W,Fabric | 124.33 | 248.66     |
|   |     | ✓   |             |   |        |            |
|  |     |     |             |   |        |            |





| Rec# | Mfg | Qty | Part Number | Part Description                     | Cust\$  | EXT Cust\$ |
|------|-----|-----|-------------|--------------------------------------|---|------------|
| 15   | HAW | 1   | HGRY-2416   | Slatwall Assembly,Plunigroup,16Hx24W | 52.33   | 52.33      |
|      |     |     |             |                                      |    |            |
| 16   | HAW | 1   | HGRY-3616   | Slatwall Assembly,Plunigroup,16Hx36W | 63.41   | 63.41      |
|      |     |     |             |                                      |   |            |
| 17   | HAW | 1   | HTB-3005    | Tackstrip 30In. X 5In.               | 35.64   | 35.64      |
|      |     |     |             |                                      |  |            |





| Rec# | Mfg | Qty | Part Number | Part Description        | Cust\$  | EXT Cust\$ |
|------|-----|-----|-------------|-------------------------|---|------------|
|      |     |     | Tag 1       | Tag 3                   |   |            |
|      |     |     | Tag 2       |                         |   |            |
| 18   | HAW | 1   | HTB-3016    | Tackboard 30In. X 16In. | 50.61   | 50.61      |
|      |     |     |             |                         |    |            |
| 19   | HAW | 1   | HTB-3605    | Tackstrip 36In. X 5In.  | 37.11   | 37.11      |
|      |     |     |             |                         |   |            |
| 20   | HAW | 3   | HTB-3616    | Tackboard 36In. X 16In. | 52.19   | 156.57     |
|      |     |     |             |                         |  |            |





| Rec#  | Mfg | Qty | Part Number     | Part Description   | Cust\$ | EXT Cust\$ |
|---|-----|-----|-----------------|--|--------|------------|
|   |     |     | Tag 1           | Tag 3  |        |            |
|   |     |     | Tag 2           |  |        |            |
| 21  | HAW | 1   | LUTS-0024-16UEP | Adaptable, Task Light, 24In., 72In.<br>Cord,Stl, Prismatic | 45.66  | 45.66      |
|   |     | ✓   |                 |  |        |            |
|    |     |     |                 |  |        |            |
| 22  | HAW | 4   | LUTS-0030-16UEP | Adaptable, Task Light, 30In., 72In.<br>Cord,Wd, Prismatic  | 47.13  | 188.52     |
|   |     | ✓   |                 |  |        |            |
|  |     |     |                 |  |        |            |
| 23  | HAW | 2   | PPD-18          | Pencil Drawer  | 21.65  | 43.30      |
|   |     | ✓   |                 |  |        |            |
|  |     |     |                 |  |        |            |





| Rec# | Mfg | Qty | Part Number | Part Description                                     | Cust\$  | EXT Cust\$ |
|------|-----|-----|-------------|--|---|------------|
| 24   | HAW | 2   | PRCN-1124-B | Ported Rway Cvr No-Pwr1 Info Opening On One Side 24" | 20.32   | 40.64      |
|      |     | ✓   |             |  |   |            |
|      |     |     |             |  |    |            |
| 25   | HAW | 2   | PRCN-1136-B | Ported Rway Cvr No-Pwr1 Info Opening On One Side 36" | 22.96   | 45.92      |
|      |     | ✓   |             |  |   |            |
|      |     |     |             |  |  |            |
| 26   | HAW | 2   | SR-2        | UniGroup,Upper Storage,Regular Shelf,24"W            | 57.78   | 115.56     |
|      |     | ✓   |             |  |   |            |
|      |     |     |             |  |  |            |



| Rec#Mfg | Qty   | Part Number | Part Description  | Cust\$  | EXT Cust\$ |
|---------|-------|-------------|---|---|------------|
|         |       | Tag 1       | Tag 3   |   |            |
|         |       | Tag 2       |   |   |            |
| 27      | HAW 6 | SR-3        | UniGroup,Upper Storage,Regular Shelf,36"W               | 62.51   | 375.06     |
|         | ✓     |             |   |   |            |
|         |       |             |   |    |            |
| 28      | HAW 2 | SR-30       | UniGroup,Upper Storage,Regular Shelf,30"W               | 60.15   | 120.30     |
|         | ✓     |             |   |   |            |
|         |       |             |   |   |            |
| 29      | HAW 2 | VPAH-24-L   | V Series,Pedestal,Attached,Box/Box/File,24" D,Full Pull | 159.99  | 319.98     |
|         | ✓     |             |   |   |            |
|         |       |             |   |  |            |





| Rec#Mfg | Qty   | Part Number<br>Tag 1<br>Tag 2 | Part Description<br>Tag 3                                      | Cust\$  | EXT Cust\$ |
|---------|-------|-------------------------------|--|---|------------|
| 30      | HAW 2 | VPAJ-24-L                     | V<br>Series, Pedestal, Attached, File/File, 24"D, Full<br>Pull | 149.68  | 299.36     |
|         | ✓     |                               |  |    |            |
| 31      | HAW 3 | WMK-78                        | Wall Mount Kit 80In.   | 41.09   | 123.27     |
|         | ✓     |                               |  |   |            |
| 32      | HAW 1 | WT-60                         | Wall Track 60In.   | 30.76   | 30.76      |
|         | ✓     |                               |  |  |            |



| Rec#Mfg | Qty   | Part Number<br>Tag 1<br>Tag 2 | Part Description<br>Tag 3                       | Cust\$ | EXT Cust\$ |
|---------|-------|-------------------------------|---|--------|------------|
| 33      | HAW 5 | WT-84                         | Wall Track 84In.                                | 41.47  | 207.35     |
|         | ✓     |                               |   |        |            |
| <hr/>   |       |                               |   |        |            |
| 34      | HAW 2 | WUCR-3636-<br>LJSAN44         | Corner,90Deg Wrap-Around Worksurface<br>36 X 36 | 113.55 | 227.10     |
|         | ✓     |                               |   |        |            |
| <hr/>   |       |                               |   |        |            |
| 35      | HAW 1 | WURA-2436-LJSA                | Rect Worksurface 24D X 36W                      | 65.96  | 65.96      |
|         | ✓     |                               |   |        |            |
| <hr/>   |       |                               |   |        |            |







| Rec# | Mfg | Qty | Part Number    | Part Description   |   | Cust\$  | EXT Cust\$ |
|------|-----|-----|----------------|--|---|---|------------|
|      |     |     | Tag 1          |  |   |   |            |
|      |     |     | Tag 2          | Tag 3  |   |   |            |
| 36   | HAW | 1   | WURA-2448-LJSA | Rect Worksurface 24D X 48W                                 |   | 89.54   | 89.54      |
|      |     |     |                |  | ✓ |   |            |
|      |     |     |                |  |   |    |            |
| 37   | HAW | 2   | WURA-2460-LJSA | Rect Worksurface 24D X 60W                                 |   | 105.18  | 210.36     |
|      |     |     |                |  | ✓ |   |            |
|      |     |     |                |  |   |   |            |
| 38   | HAW | 5   | ZEBD-1600-PP   | Unigroup/Too/Places,Cntlvr<br>Brkt, Standard, 16.5In.D, Bh |   | 22.82   | 114.10     |
|      |     |     |                |  | ✓ |   |            |
|      |     |     |                |  |   |  |            |







| Rec#Mfg | Qty   | Part Number<br>Tag 1<br>Tag 2 | Part Description<br>Tag 3                 | Cust\$  | EXT Cust\$ |
|---------|-------|-------------------------------|---|---|------------|
| 39      | HAW 2 | ZEBR-0000-PN                  | Worksurface, Rear-Corner Bracket, if, Svc | 4.05  | 8.10       |
|         | ✓     |                               |   |   |            |
|         |       |                               |   |    |            |
| 40      | HAW 2 | ZUBF-0000-PN                  | Flush Mount Plate                         | 5.31  | 10.62      |
|         | ✓     |                               |   |   |            |
| 41      | HTL 1 | HMBPOST                       | Huddle Post Leg Base                      | 137.24  | 137.24     |
|         | ✓     |                               |   |   |            |
|         |       |                               |   |  |            |
| 42      | HTL 1 | HMT1848G                      | Huddle 18x48 Table Top w/Edgeband         | 120.19  | 120.19     |
|         | ✓     |                               |   |   |            |
|         |       |                               |   |  |            |





| Rec#Mfg | Qty   | Part Number    | Part Description  | Cust\$ | EXT Cust\$ |
|---------|-------|----------------|---|--------|------------|
|         |       | Tag 1          |   |        |            |
|         |       | Tag 2          | Tag 3   |        |            |
| 43      | RAN 1 | JFP21/S        | Keyboard Tray,Comfort Wrist Rest-21In.<br>Track                                 |        |            |
|         | ?     | *DOUBLE CHECK* |   | 173.96 | 173.96     |
| 44      | SAF 1 | 5288GR         | 36"W x 24"D x 72"H Wire Shelving Starter<br>Unit, Wt. capacity minimum 1000lbs. |        |            |
|         | ✓     |                |   | 190.30 | 190.30     |

Total Customer: \$8,102.23

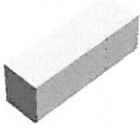



| Rec# | Mfg | Qty | Part Number | Part Description                   | Cust\$  | EXT Cust\$ |
|------|-----|-----|-------------|------------------------------------|---|------------|
|      |     |     | Tag 1       | Tag 3                              |   |            |
|      |     |     | Tag 2       |                                    |   |            |
| 1    | IDC | 1   | 66-1530TU   | 30" Top Unit                       | 253.81  | 253.81     |
|      |     |     | ✓           |                                    |   |            |
|      |     |     |             |                                    |    |            |
| 2    | IDC | 2   | 66-1536WD   | Wall Mounted Door Hutch, 36W x 42H | 262.73  | 525.46     |
|      |     |     | ✓           |                                    |   |            |
|      |     |     |             |                                    |   |            |
| 3    | IDC | 1   | 66-1548WD   | Wall Mounted Door Hutch, 48W x 42H | 402.34  | 402.34     |
|      |     |     | ✓           |                                    |   |            |
|      |     |     |             |                                    |  |            |





| Rec# | Mfg | Qty | Part Number    | Part Description  | Cust\$  | EXT Cust\$ |
|------|-----|-----|----------------|---|---|------------|
|      |     |     | Tag 1<br>Tag 2 | Tag 3   |   |            |
| 4    | IDC | 1   | 66-1622CD      | Center Drawer, 22W x 16D  | 108.84  | 108.84     |
|      |     |     |                |   |    |            |
| 5    | IDC | 2   | 66-2415PD1     | Letter Width Modular Pedestal, B/B/F, 15-3/4W x 23-1/4D x 28-1/4H | 323.83  | 647.66     |
|      |     |     |                |   |   |            |
| 6    | IDC | 1   | 66-2430EP      | Modular End Panel, 23-1/4W x 1D x 28-1/4H                         | 96.34   | 96.34      |
|      |     |     |                |   |  |            |





| Rec# | Mfg | Qty | Part Number | Part Description                   | Cust\$  | EXT Cust\$ |
|------|-----|-----|-------------|------------------------------------|---|------------|
|      |     |     | Tag 1       | Tag 3                              |   |            |
|      |     |     | Tag 2       |                                    |   |            |
| 7    | IDC | 1   | 66-2430L2   | Two Drawer Lateral File, 24D x 30W | 415.27  | 415.27     |
|      |     |     | ✓           |                                    |   |            |
|      |     |     |             |                                    |    |            |
| 8    | IDC | 1   | 66-2436TP   | Modular Cabinet Top, 24D x 36W     | 101.25  | 101.25     |
|      |     |     | ✓           |                                    |   |            |
|      |     |     |             |                                    |   |            |
| 9    | IDC | 2   | 66-2466TP   | Modular Cabinet Top, 24D x 66W     | 155.23  | 310.46     |
|      |     |     | ✓           |                                    |   |            |
|      |     |     |             |                                    |  |            |



| Rec#Mfg | Qty   | Part Number | Part Description                          | Cust\$  | EXT Cust\$ |
|---------|-------|-------------|---|---|------------|
|         |       | Tag 1       | Tag 3                                     |   |            |
|         |       | Tag 2       |   |   |            |
| 10      | IDC 1 | 66-2812SP   | Modular Support Panel, 12W x 1D x 28-1/4H | 67.36   | 67.36      |
|         | ✓     |             |   |    |            |
| 11      | IDC 1 | 66-3072SU1  | Storage Cabinet w/Lateral File, 30W x 24D | 925.13  | 925.13     |
|         | ✓     |             |   |   |            |
| 12      | IDC 1 | 66-3628BP   | Modular Back Panel, 36W x 28-1/4H x 3/4D  | 74.48   | 74.48      |
|         | ✓     |             |   |  |            |



| Rec# | Mfg | Qty | Part Number | Part Description                               | Cust\$  | EXT Cust\$ |
|------|-----|-----|-------------|--|---|------------|
|      |     |     | Tag 1       | Tag 3  |   |            |
|      |     |     | Tag 2       |  |   |            |
| 13   | IDC | 1   | 66-3636CU   | Corner Unit, 36D x 36W                         | 438.02  | 438.02     |
|      |     |     | ✓           |  |    |            |
| 14   | IDC | 2   | 66-6628BP   | Modular Back Panel, 66W x 28-1/4H x 3/4D       | 131.14  | 262.28     |
|      |     |     | ✓           |  |   |            |
| 15   | IDC | 1   | TB-6648W    | Canvas Wall Mounted Hutch Tackboard, 48" Hutch | 125.78  | 125.78     |
|      |     |     | ✓           |  |  |            |





| Rec#  | Mfg | Qty | Part Number | Part Description                                  | Cust\$ | EXT Cust\$ |
|-------|-----|-----|-------------|---|--------|------------|
|       |     |     | Tag 1       | Tag 3   |        |            |
|       |     |     | Tag 2       |   |        |            |
| 16    | IDC | 1   | TB-6672W    | Canvas Wall Mounted Hutch Tackboard,<br>72" Hutch | 164.15 | 164.15     |
|       |     |     | ✓           |   |        |            |
| <hr/> |     |     |             |   |        |            |
| 17    | IDC | 3   | TL-0824     | 24" Tasklight                                     | 97.24  | 291.72     |
|       |     |     | ✓           |   |        |            |
| <hr/> |     |     |             |   |        |            |
| 18    | IDC | 4   | KEYS        | Keyed Alike, Lock Plus and Key                    | 0.00   | 0.00       |
|       |     |     | ?           |   |        |            |



Total Customer: \$5,210.35





| Rec#  | Mfg | Qty | Part Number | Part Description  | Cust\$ | EXT Cust\$ |
|---|-----|-----|-------------|---|--------|------------|
|   |     |     | Tag 1       | Tag 2   | Tag 3  |            |
| 1   | GUS | 2   | 1936P-4F12  | LATERAL FILES-1900P Series-4 Drawer lateral file 19.25D x 36W x 51.891H | 463.91 | 927.82     |
|   |     |     | ✓           |   |        |            |
|    |     |     |             |   |        |            |
| 2   | GUS | 8   | FBB         | LATERAL ACCESSORIES-Front to Back Hanging File Bars - 1 pr. grey        | 7.85   | 62.80      |
|   |     |     | ✓           |   |        |            |
| 3   | IDC | 3   | 1-GRMTSL    | Silver Grommet per 3.1.4.4  | 8.92   | 26.76      |
|   |     |     | ✓           | DRILL ON SITE   |        |            |
| 4   | IDC | 7   | 66-1530WD   | Wall Mounted Door Hutch, 30W x 42H                                      | 227.93 | 1595.51    |
|   |     |     | ✓           |   |        |            |
|  |     |     |             |   |        |            |



| Rec#  | Mfg | Qty | Part Number | Part Description  | Cust\$ | EXT Cust\$ |
|---|-----|-----|-------------|---|--------|------------|
|   |     |     | Tag 1       | Tag 2   | Tag 3  |            |
| 5   | IDC | 1   | 66-1622CD   | Center Drawer, 22W x 16D  | 108.84 | 108.84     |
|   |     |     | ✓           |   |        |            |
|    |     |     |             |   |        |            |
| 6   | IDC | 1   | 66-2415PD1  | Letter Width Modular Pedestal, B/B/F, 15-3/4W x 23-1/4D x 28-1/4H | 323.83 | 323.83     |
|   |     |     | ✓           |   |        |            |
|   |     |     |             |   |        |            |
| 7   | IDC | 1   | 66-2460TP   | Modular Cabinet Top, 24D x 60W                                    | 148.54 | 148.54     |
|   |     |     | ✓           |   |        |            |
|  |     |     |             |   |        |            |









| Rec# | Mfg | Qty | Part Number   | Part Description  | Cust\$  | EXT Cust\$ |
|------|-----|-----|---------------|---|---|------------|
|      |     |     | Tag 1         | Tag 3   |   |            |
|      |     |     | Tag 2         |   |   |            |
| 8    | IDC | 1   | 66-6028BP     | Modular Back Panel, 60W x 28-1/4H x 3/4D  | 128.47  | 128.47     |
|      |     |     |               |   |    |            |
| 9    | IDC | 1   | 68-3066RP     | Right Ped Desk, 30D x 66W   | 610.21  | 610.21     |
|      |     |     |               |   |   |            |
| 10   | IDC | 1   | S66-243636OL2 | Canvas 2-drawer lateral file 36"W x 24"D. To have an approximate 6" open shelf above drawers. Overall total height of unit 36"H | 545.31  | 545.31     |
|      |     |     |               |   |   |            |
| 11   | IDC | 4   | TB-6630W      | Canvas Wall Mounted Hutch Tackboard, 30" Hutch  | 131.14  | 524.56     |
|      |     |     |               |   |  |            |





| Rec#                   | Mfg | Qty | Part Number | Part Description               | Cust\$ | EXT Cust\$        |
|------------------------|-----|-----|-------------|--------------------------------|--------|-------------------|
| 12                     | IDC | 4   | TL-0824     | 24" Tasklight                  | 97.24  | 388.96            |
|                        | ✓   |     |             |                                |        |                   |
| 13                     | IDC | 3   | KEYS        | Keyed Alike, Lock Plus and Key | 0.00   | 0.00              |
|                        | ?   |     |             |                                |        |                   |
| <b>Total Customer:</b> |     |     |             |                                |        | <b>\$5,391.61</b> |



| Rec#Mfg | Qty   | Part Number   | Part Description   | Cust\$  | EXT Cust\$ |
|---------|-------|---------------|--|---|------------|
|         |       | Tag 1         | Tag 3  |   |            |
|         |       | Tag 2         |  |   |            |
| 1       | HAF 1 | JCPV-0330-SSJ | X Series,Combo Unit,39.5"H x 30"W,LatFile,3,4HI,Steel Drawer Front,Steel Door Front,Steel Lock Material,J Pull,Freestanding,Touc | 501.09  | 501.09     |
|         | ✓     |               |  |   |            |
|         |       |               |  |    |            |
| 2       | HAF 2 | JSPY-0330-SJ  | X Series,3H x 30"W,Closed Cabinet,Two Doors,Steel Drawer Front,Steel Lock Rail Material,Freestanding Mount                       | 345.09  | 690.18     |
|         | ✓     |               |  |   |            |
|         |       |               |  |  |            |
| 3       | HAF 1 | JTCT-1960-L   | X Series,Common Top 18 3/4"D X 60"W  | 167.27  | 167.27     |
|         | ✓     |               |  |   |            |
|         |       |               |  |  |            |

| Rec#Mfg | Qty   | Part Number<br>Tag 1<br>Tag 2 | Part Description<br>Tag 3                            | Cust\$ | EXT Cust\$  |
|---------|-------|-------------------------------|--|--------|---|
| 4       | HAF 1 | JTFT-1930-L                   | X Series,File Top 18 3/4"D X 30"W                    | 94.55  | 94.55   |
|         | ✓     |                               |  |        |   |
|         |       |                               |  |        |    |
| 5       | HAJ 1 | LSET-7                        | HW,Lock Set, Keyed Alike,Lock Plug And Key, Qty Of 7 | 0.00   | 0.00  |
|         | ✓     |                               |  |        |   |
| 6       | HAW 1 | FDRF-2                        | UniGroup,Upper Storage,Flipper Door,24"W,Fabric      | 118.76 | 118.76  |
|         | ✓     |                               |  |        |   |
|         |       |                               |  |        |  |
| 7       | HAW 2 | FDRF-30                       | UniGroup,Upper Storage,Flipper Door,30"W,Fabric      | 124.33 | 248.66  |
|         | ✓     |                               |  |        |   |
|         |       |                               |  |        |  |



| Rec#  | Mfg   | Qty | Part Number | Part Description                          | Cust\$ | EXT Cust\$ |
|---|-------|-----|-------------|---|--------|------------|
|   |       |     | Tag 1       | Tag 3                                     |        |            |
|   |       |     | Tag 2       |   |        |            |
| 8   | HAW 1 | 1   | SR-2        | UniGroup,Upper Storage,Regular Shelf,24"W | 57.78  | 57.78      |
|   |       |     | ✓           |   |        |            |
|    |       |     |             |   |        |            |
| 9   | HAW 2 | 2   | SR-30       | UniGroup,Upper Storage,Regular Shelf,30"W | 60.14  | 120.28     |
|   |       |     | ✓           |   |        |            |
|   |       |     |             |   |        |            |
| 10  | HAW 3 | 3   | WT-84       | Wall Track 84In.                          | 41.47  | 124.41     |
|   |       |     | ✓           |   |        |            |
|  |       |     |             |   |        |            |

Total Customer: \$2,122.98

STATE OF WEST VIRGINIA  
Purchasing Division

**PURCHASING AFFIDAVIT**

**MANDATE:** Under W. Va. Code §5A-3-10a, no contract or renewal of any contract may be awarded by the state or any of its political subdivisions to any vendor or prospective vendor when the vendor or prospective vendor or a related party to the vendor or prospective vendor is a debtor and: (1) the debt owed is an amount greater than one thousand dollars in the aggregate; or (2) the debtor is in employer default.

**EXCEPTION:** The prohibition listed above does not apply where a vendor has contested any tax administered pursuant to chapter eleven of the W. Va. Code, workers' compensation premium, permit fee or environmental fee or assessment and the matter has not become final or where the vendor has entered into a payment plan or agreement and the vendor is not in default of any of the provisions of such plan or agreement.

**DEFINITIONS:**

**"Debt"** means any assessment, premium, penalty, fine, tax or other amount of money owed to the state or any of its political subdivisions because of a judgment, fine, permit violation, license assessment, defaulted workers' compensation premium, penalty or other assessment presently delinquent or due and required to be paid to the state or any of its political subdivisions, including any interest or additional penalties accrued thereon.

**"Employer default"** means having an outstanding balance or liability to the old fund or to the uninsured employers' fund or being in policy default, as defined in W. Va. Code § 23-2c-2, failure to maintain mandatory workers' compensation coverage, or failure to fully meet its obligations as a workers' compensation self-insured employer. An employer is not in employer default if it has entered into a repayment agreement with the Insurance Commissioner and remains in compliance with the obligations under the repayment agreement.

**"Related party"** means a party, whether an individual, corporation, partnership, association, limited liability company or any other form or business association or other entity whatsoever, related to any vendor by blood, marriage, ownership or contract through which the party has a relationship of ownership or other interest with the vendor so that the party will actually or by effect receive or control a portion of the benefit, profit or other consideration from performance of a vendor contract with the party receiving an amount that meets or exceeds five percent of the total contract amount.

**AFFIRMATION:** By signing this form, the vendor's authorized signer affirms and acknowledges under penalty of law for false swearing (W. Va. Code §61-5-3) that neither vendor nor any related party owe a debt as defined above and that neither vendor nor any related party are in employer default as defined above, unless the debt or employer default is permitted under the exception above.

**WITNESS THE FOLLOWING SIGNATURE:**

Vendor's Name: Capitol Business Interiors

Authorized Signature: Amanda Dickens Date: 5/14/14

State of West Virginia

County of Kanawha, to-wit:

Taken, subscribed, and sworn to before me this 14 day of May, 2014.

My Commission expires June 1, 2022.

**AFFIX SEAL HERE**

**NOTARY PUBLIC**

Jessica R. Houston  
Purchasing Affidavit (Revised 07/01/2012)

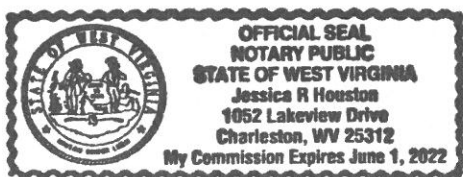



VENDOR PREFERENCE CERTIFICATE

Certification and application\* is hereby made for Preference in accordance with West Virginia Code, §5A-3-37. (Does not apply to construction contracts). West Virginia Code, §5A-3-37, provides an opportunity for qualifying vendors to request (at the time of bid) preference for their residency status. Such preference is an evaluation method only and will be applied only to the cost bid in accordance with the West Virginia Code. This certificate for application is to be used to request such preference. The Purchasing Division will make the determination of the Resident Vendor Preference, if applicable.

1. Application is made for 2.5% resident vendor preference for the reason checked:

- Bidder is an individual resident vendor and has resided continuously in West Virginia for four (4) years immediately preceding the date of this certification; or,
[X] Bidder is a partnership, association or corporation resident vendor and has maintained its headquarters or principal place of business continuously in West Virginia for four (4) years immediately preceding the date of this certification; or 80% of the ownership interest of Bidder is held by another individual, partnership, association or corporation resident vendor who has maintained its headquarters or principal place of business continuously in West Virginia for four (4) years immediately preceding the date of this certification; or,
Bidder is a nonresident vendor which has an affiliate or subsidiary which employs a minimum of one hundred state residents and which has maintained its headquarters or principal place of business within West Virginia continuously for the four (4) years immediately preceding the date of this certification; or,

2. Application is made for 2.5% resident vendor preference for the reason checked:

- [X] Bidder is a resident vendor who certifies that, during the life of the contract, on average at least 75% of the employees working on the project being bid are residents of West Virginia who have resided in the state continuously for the two years immediately preceding submission of this bid; or,

3. Application is made for 2.5% resident vendor preference for the reason checked:

- Bidder is a nonresident vendor employing a minimum of one hundred state residents or is a nonresident vendor with an affiliate or subsidiary which maintains its headquarters or principal place of business within West Virginia employing a minimum of one hundred state residents who certifies that, during the life of the contract, on average at least 75% of the employees or Bidder's affiliate's or subsidiary's employees are residents of West Virginia who have resided in the state continuously for the two years immediately preceding submission of this bid; or,

4. Application is made for 5% resident vendor preference for the reason checked:

- [X] Bidder meets either the requirement of both subdivisions (1) and (2) or subdivision (1) and (3) as stated above; or,

5. Application is made for 3.5% resident vendor preference who is a veteran for the reason checked:

- Bidder is an individual resident vendor who is a veteran of the United States armed forces, the reserves or the National Guard and has resided in West Virginia continuously for the four years immediately preceding the date on which the bid is submitted; or,

6. Application is made for 3.5% resident vendor preference who is a veteran for the reason checked:

- Bidder is a resident vendor who is a veteran of the United States armed forces, the reserves or the National Guard, if, for purposes of producing or distributing the commodities or completing the project which is the subject of the vendor's bid and continuously over the entire term of the project, on average at least seventy-five percent of the vendor's employees are residents of West Virginia who have resided in the state continuously for the two immediately preceding years.

7. Application is made for preference as a non-resident small, women- and minority-owned business, in accordance with West Virginia Code §5A-3-59 and West Virginia Code of State Rules.

- Bidder has been or expects to be approved prior to contract award by the Purchasing Division as a certified small, women- and minority-owned business.

Bidder understands if the Secretary of Revenue determines that a Bidder receiving preference has failed to continue to meet the requirements for such preference, the Secretary may order the Director of Purchasing to: (a) reject the bid; or (b) assess a penalty against such Bidder in an amount not to exceed 5% of the bid amount and that such penalty will be paid to the contracting agency or deducted from any unpaid balance on the contract or purchase order.

By submission of this certificate, Bidder agrees to disclose any reasonably requested information to the Purchasing Division and authorizes the Department of Revenue to disclose to the Director of Purchasing appropriate information verifying that Bidder has paid the required business taxes, provided that such information does not contain the amounts of taxes paid nor any other information deemed by the Tax Commissioner to be confidential.

Under penalty of law for false swearing (West Virginia Code, §61-5-3), Bidder hereby certifies that this certificate is true and accurate in all respects; and that if a contract is issued to Bidder and if anything contained within this certificate changes during the term of the contract, Bidder will notify the Purchasing Division in writing immediately.

Bidder: Capitol Business Interiors Signed: Amanda Diakem

Date: 5/14/14 Title: Sales - Design

**CERTIFICATION AND SIGNATURE PAGE**

By signing below, I certify that I have reviewed this Solicitation in its entirety; understand the requirements, terms and conditions, and other information contained herein; that I am submitting this bid or proposal for review and consideration; that I am authorized by the bidder to execute this bid or any documents related thereto on bidder's behalf; that I am authorized to bind the bidder in a contractual relationship; and that to the best of my knowledge, the bidder has properly registered with any State agency that may require registration.

Capital Business Interiors  
(Company)

Amanda Dickens  
(Authorized Signature)

Amanda Dickens  
(Representative Name, Title)

304-346-3342      304-346-3350  
(Phone Number)      (Fax Number)

5/14/14  
(Date)

**ADDENDUM ACKNOWLEDGEMENT FORM**  
**SOLICITATION NO.: DRS140335**

**Instructions:** Please acknowledge receipt of all addenda issued with this solicitation by completing this addendum acknowledgment form. Check the box next to each addendum received and sign below. Failure to acknowledge addenda may result in bid disqualification.

**Acknowledgment:** I hereby acknowledge receipt of the following addenda and have made the necessary revisions to my proposal, plans and/or specification, etc.

**Addendum Numbers Received:**

(Check the box next to each addendum received)

- |                                     |                |                          |                 |
|-------------------------------------|----------------|--------------------------|-----------------|
| <input checked="" type="checkbox"/> | Addendum No. 1 | <input type="checkbox"/> | Addendum No. 6  |
| <input checked="" type="checkbox"/> | Addendum No. 2 | <input type="checkbox"/> | Addendum No. 7  |
| <input checked="" type="checkbox"/> | Addendum No. 3 | <input type="checkbox"/> | Addendum No. 8  |
| <input checked="" type="checkbox"/> | Addendum No. 4 | <input type="checkbox"/> | Addendum No. 9  |
| <input type="checkbox"/>            | Addendum No. 5 | <input type="checkbox"/> | Addendum No. 10 |

I understand that failure to confirm the receipt of addenda may be cause for rejection of this bid. I further understand that any verbal representation made or assumed to be made during any oral discussion held between Vendor's representatives and any state personnel is not binding. Only the information issued in writing and added to the specifications by an official addendum is binding.

Capital Business Interiors  
Company

Amanda Dickens  
Authorized Signature

5/14/14  
Date

NOTE: This addendum acknowledgment should be submitted with the bid to expedite document processing.