

**AARON'S BUSINESS SOLUTIONS**  
**1041 8<sup>TH</sup> AVENUE**  
**HUNTINGTON, WV 25701**  
**304-522-7022**

**PROPOSAL #000020 – DHHR,**  
**BUREAU FOR CHILDREN & FAMILIES**  
**NICHOLAS COUNTY**

<u>QTY</u>	<u>DESCRIPTION</u>	<u>UNIT</u>	<u>EXT</u>
(48)	6' X 7' KNOLL MORRISON RE-FURBISHED WORKSTATIONS CONSISTING THE FOLLOWING: NEW HP LAMINATE WORKSURFACES W/GROMMETS NEW PANEL FABRIC ON 64"H PANELS NEW TOP CAPS AND RACEWAY COVERS RE-PAINTED PED'S, SHELVES AND OH'S <b>EACH STATION WILL CONSIST OF:</b> 24"X36" CORNER SURFACE 24" X 36 STRAIGHT SURFACE 24" X 48 STRAIGHT SURFACE (3) DUPLEX PER STATION 30"W WING PANELS COAT HOOK 36"W X 11"H TACKBOARD POWER POLES (TO BE INSTALLED BY OTHERS) (1) EA., 24"D F/F & B/B/F/ PEDESTALS W/LOCK (1) EA., 36" & 48" FLIPPER DOOR UNITS W/TASK LIGHTS (1) ARTICULATING KEYBOARD TRAY W/PALM REST (1) TOOLBAR WITH IN/OUT HORIZONTAL BASKET (1) VERTICAL W/3-SLOTS (12) 72" X 24" LAMINATE WORKSURFACES SPANNING THE ENTIRE BACK OF WORKSTATIONS WHERE NOTED W/24"W WING PANELS, 2-PEDS AND SHELVES TAG: ROOM 123 AND ROOM 138 (24) UNITS EACH	\$2,545.00	\$122,160.00
(38)	GLOBAL MID-BACK TASK CHAIR'S W/ADJ ARMS #5336-5 SUPRA-X MULTI-TILTER PNEUMATIC HT ADJ, TILT-TENSION CONTROL WATERFALL SEAT, CONTOURED SEAT, BACK HT ADJUSTMENT, LUMBAR SUPPORT BACK ANGLE, FORWARD TILT LOCK, 5-STAR BASE UPH: GRADE III PATTERN: TBD BASE: BLACK TAG: ROOM 123 AND ROOM 138 – SEATING	\$273.00	\$10,347.00

<u>QTY</u>	<u>DESCRIPTION</u>	<u>UNIT</u>	<u>EXT</u>
(10)	GLOBAL BIG & TALL TASK CHAIR'S W/ADJ ARMS #TS5451-3 MID-BACK MULTITILT, SEAT DEPTH, PNEUMATIC HT ADJ, TILT-TENSION CONTROL WATERFALL SEAT, CONTOURED SEAT, BACK HT ADJUSTMENT, LUMBAR SUPPORT BACK ANGLE, FORWARD TILT LOCK, 5-STAR BASE UPH: GRADE III PATTERN: TBD BASE: BLACK TAG: ROOM 123 AND ROOM 138 – SEATING	\$333.00	\$3,330.00
(4)	6' X 7' KNOLL MORRISON RE-FURBISHED WORKSTATIONS CONSISTING THE FOLLOWING: NEW HP LAMINATE WORKSURFACES W/GROMMETS NEW PANEL FABRIC ON 64"H PANELS NEW TOP CAPS AND RACEWAY COVERS RE-PAINTED PED'S, SHELVES AND OH'S <b>EACH STATION WILL CONSIST OF:</b> 24"X36" CORNER SURFACE 24" X 36 STRAIGHT SURFACE 24" X 48 STRAIGHT SURFACE (3) DUPLEX PER STATION 30"W WING PANELS COAT HOOK 36"W X 11"H TACKBOARD POWER POLES (TO BE INSTALLED BY OTHERS) (1) EA., 24"D F/F & B/B/F/ PEDESTALS W/LOCK (1) EA., 36" & 48" FLIPPER DOOR UNITS W/TASK LIGHTS (1) ARTICULATING KEYBOARD TRAY W/PALM REST (1) TOOLBAR WITH IN/OUT HORIZONTAL BASKET (1) VERTICAL W/3-SLOTS TAG: ROOM 137	\$2,545.00	\$25,450.00
(4)	GLOBAL MID-BACK TASK CHAIR'S W/ADJ ARMS #5336-5 SUPRA-X MULTI-TILT PNEUMATIC HT ADJ, TILT-TENSION CONTROL WATERFALL SEAT, CONTOURED SEAT, BACK HT ADJUSTMENT, LUMBAR SUPPORT BACK ANGLE, FORWARD TILT LOCK, 5-STAR BASE UPH: GRADE III PATTERN: TBD BASE: BLACK TAG: ROOM 137	\$273.00	\$1,092.00

<u>QTY</u>	<u>DESCRIPTION</u>	<u>UNIT</u>	<u>EXT</u>
(1)	SURFACE WORKS HP LAMINATE TABLE TOP W/4-LEG BASE, W/LOCKING CASTERS DIM: 60"W X 24"D X 40"H LAMINATE: STANDARD – TBD TAG: MAIL AREA ROOM 124	\$552.00	\$552.00
(1)	GLOBAL SUPRA X STOOL W/FOOT RING #5338-6 W/ADJ ARMS, SWIVEL TILT, ADJ LUMBAR SUPPORT, PNEUMATIC HT ADJ. UPH: GRADE III PATTERN: TBD TAG: MAIL AREA ROOM 124	\$377.00	\$377.00
(3)	GLOBAL METAL DBL DOOR STORAGE CABINETS #9342P-5S1 – W/LOCK, ONE FIXED AND THREE ADJ SHELVES, ADJ GLIDES DIM: 5-HIGH X 42"W COLOR: STANDARD – TBD TAG: STORAGE AREA, OUTSIDE RM 124	\$240.00	\$720.00
(2)	GLOBAL MID-BACK TASK CHAIR'S W/ADJ ARMS #5336-5 SUPRA-X MULTI-TILTER PNEUMATIC HT ADJ, TILT-TENSION CONTROL WATERFALL SEAT, CONTOURED SEAT, BACK HT ADJUSTMENT, LUMBAR SUPPORT BACK ANGLE, FORWARD TILT LOCK, 5-STAR BASE UPH: GRADE III PATTERN: TBD BASE: BLACK TAG: RECEPTIONIST ROOM 125	\$273.00	\$546.00
(2)	GLOBAL HP MULTI FILE UNIT: #A2436MDL: DRAWER CABINET, LEFT TWO BOX DRAWERS ON RIGHT ONE FILE DRAWER ON LEFT ONE LATERAL FILE ON BOTTOM DIM: 36"W X 24"D X 29"H TAG: MISCELLANEOUS ITEMS (125)	\$705.00	\$1410.00
(10)	GLOBAL FREESTANDING HP LAMINATE DESK #A3048T - W/3MM EDGE DETAIL, CENTER REAR GROMMET, 1-BBF PEDESTAL W/LOCK LAMINATE: STANDARD – TBD TAG: INTERVIEW ROOMS 126-135	\$408.00	\$4,080.00
(10)	GLOBAL PEDESTALS FOR ABOVE DESKS #AFPBBF28 - BBF PED W/LOCK, PENCIL TRAY DIM: 16"W X 28"D X 28"H LAMINATE: STANDARD - TBD	\$381.00	\$3,810.00

<u>QTY</u>	<u>DESCRIPTION</u>	<u>UNIT</u>	<u>EXT</u>
(10)	ARTICULATINGKEYBOARD TRAYS TAG: INTERVIEW ROOMS 126-135	\$343.00	\$3,430.00
(10)	#ATB3416 GLOBAL WALL MOUNTED TACKBOARDS UPH: GRADE III PATTERN: TBD TAG: INTERVIEW ROOMS 126-135	\$84.00	\$840.00
(10)	OFFICE STAR DELUXE TASK CHAIR'S #33107 – W/HEIGHT AND WIDTH ADJ ARMS, RATCHET BACK HEIGHT ADJ, 5-STAR BASE UPH: GRADE A PATTERN: TBD TAG: INTERVIEW ROOMS 126-135	\$169.00	\$1,690.00
(20)	GLOBAL GUEST SIDE CHAIRS W/ARMS #6900 – METAL FRAME 4-LEGS UPH: GRADE III PATTERN: TBD TAG: (2) EA, INTEWRVIEW ROOMS 126-135	\$172.00	\$3,440.00
(1)	SURFACE WORKS PRINTER TABLE W/GROMMET #TTEDR.1848.EBR W/4-LEGS, LOCKING CASTERS DIM: 48"W X 18"D VINYL EDGE DETAIL LAMINATE: STANDARD – TBD TAG: PRINTER TABLE OUTSIDE RM 125	\$497.00	4497.00
(13)	GLOBAL ADAPTABILITIES "D" SHAPED DESK W/GROMMET, FULL MODESTY PANEL, H-BASE, HP LAMINATE, 1" T 3MM EDGE DETAIL DIM: 72"W X 36"DX 29"H LAMINATE: STANDARD –TBD TAG: ROOMS 109, 111-121 & 150 (5-LEFT HAND & 8-RIGHT HAND)	\$504.00	\$6,552.00
(13)	GLOBAL ADAPTABILITIES RETURN W/GROMMET, FULL MODESTY PANEL, H-BASE, HP LAMINATE, 1" T 3MM EDGE DETAIL FF PEDESTAL W/LOCK DIM: 48"W X 24"D X 29"H LAMINATE: STANDARD –TBD TAG: ROOMS 109, 111-121 & 150 (5-RIGHT HAND & 8-LEFT HAND)	\$536.00	\$6,968.00

<u>QTY</u>	<u>DESCRIPTION</u>	<u>UNIT</u>	<u>EXT</u>
(13)	GLOBAL ADAPTABILITIES HP LAMINATE HUTCH W/O DOORS, CLOSED BACK #A48HO�B – W/ONE FIXED SHELF, GROMMET, FLEXABLE SWEEP FOR WIRE MANAGEMENT, TASK LIGHT DIM: 48”W X 15”D X 36”H LAMINATE: STANDARD – TBD TAG: ROOMS 109, 111-121 & 150	\$275.00	\$3,575.00
(13)	GLOBAL TACK-BOARDS DIM: 46”W X 1”T X 15”H UPH: GRADE III PATTERN: TBD TAG: ROOMS 109, 111-121 & 150	\$89.00	\$1,157.00
(13)	GREAT OPENINGS 36”W TASK LIGHTS #VT36-BK COLOR: BLACK TAG: ROOMS 109, 111-121 & 150	\$116.00	\$1,508.00
(13)	GLOBAL ADAPTABILITIES MOBILE PEDS #AMPBBF22 BBF DRAWERS W/LOCK, PENCIL TRAY, DIM: 23”W X 16”D X 28”H LAMINATE: STANDARD TAG: ROOMS 109, 111-121 & 150	\$448.00	\$5,824.00
(13)	ARTICULATING KEYBOARDS TRAYS W/PALM REST TAG: ROOMS 109, 111-121 & 150	\$343.00	\$3,430.00
(13)	FREESTANDING IN/OUT 2-LEVEL #DEF582704 PAPER TRAY. TAG: ROOMS 109, 111-121 & 150	\$29.99	\$389.00
(13)	FREESTANDING DIAGONAL TRAY #UNV08113 3-SLOTS TAG: ROOMS 109, 111-121 & 150	\$12.50	\$162.50
(13)	GLOBAL MULTI-TILTER SCALE TASK #3022-3 MID-BACK CHAIR W/ADJ ARMS PNEUMATIC HT ADJ, TILT-TENSION CONTROL WATERFALL SEAT, CONTOURED SEAT, BACK HT ADJUSTMENT, LUMBAR SUPPORT BACK ANGLE, FORWARD TILT LOCK, 5-STAR BASE UPH: GRADE III PATTERN: TBD BASE: BLACK TAG: ROOMS 109, 111-121 & 150	\$392.00	\$5,096.00

<u>QTY</u>	<u>DESCRIPTION</u>	<u>UNIT</u>	<u>EXT</u>
(26)	GLOBAL GUEST SIDE CHAIRS W/ARMS #6900 – METAL FRAME, W/ 4-LEGS UPH: GRADE III PATTERN: TBD TAG: ROOMS 109, 111-121 & 150	\$172.00	\$4,472.00
(13)	GLOBAL ADAPTABILITIES 4-DRAWER #A2036S4 HP LAMINATE LATERAL FILE W/LOCK DIM: 36"W X 20"D X 49.5"H LAMINATE: STANDARD – TBD TAG: ROOMS 109, 111-121 & 150	\$940.00	\$12,220.00
(13)	GLOBAL ADAPTABILITIES OPEN BOOKCASE #ABC48 W/THREE ADJUSTABLE SHELVES DIM: 36"W X 12"D X 48"H HP LAMINATE: STANDARD – TBD TAG: ROOMS 109, 111-121 & 150	\$293.00	\$3,809.00
(3)	GLOBAL 5-DR METAL LATERAL FILE W/LOCK, ADJUSTABLE GLIDES DIM: 42"W X 18"D X 65.25"H LAMINATE: STANDARD – TBD TAG: STORAGE AREA, OUTSIDE RM 109	\$651.00	\$1,953.00
(1)	GLOBAL ADAPTABILITIES "D" SHAPED DESK, RIGHT #A3672FIR - W/GROMMET, FULL MODESTY PANEL, H-BASE, HP LAMINATE, 1"T 3MM EDGE DETAIL DIM: 72"W X 36"D X 29"H HP LAMINATE: STANDARD –TBD TAG: ROOM 122	\$504.00	\$504.00
(1)	GLOBAL ADAPTABILITES RETURN, LEFT #A2448L4 – W/GROMMET, FULL TO FLOOR, HP LAMINATE, 1"T 3MM EDGE DETAIL FF PEDESTAL W/LOCK DIM: 48"W X 24"D X 29"H LAMINATE: STANDARD –TBD TAG: ROOM 122	\$536.00	\$536.00
(1)	GLOBAL ADAPTABILITIES HP LAMINATE HUTCH W/O DOORS, CLOSED BACK #A48HOCB – W/ONE FIXED SHELF, GROMMET, FLEXABLE SWEEP FOR WIRE MANAGEMENT, TASK LIGHT DIM: 48"W X 15"D X 36"H LAMINATE: STANDARD – TBD TAG: ROOM 122	\$275.00	\$275.00

<u>QTY</u>	<u>DESCRIPTION</u>	<u>UNIT</u>	<u>EXT</u>
(1)	GLOBAL TACK-BOARDS DIM:46"W X 1"T X 15"H UPH: GRADE III PATTERN: TBD TAG: ROOM 122	\$89.00	\$89.00
(1)	GREAT 36"W OPENINGS TASK LIGHTS #VDT36BK COLOR: BLACK TAG: ROOM 122	\$116.00	\$116.00
(1)	GLOBAL ADAPTABILITIES MOBILE PEDS #AMPBBF22 BBF DRAWERS W/LOCK, PENCIL TRAY, DIM: 23"W X 16"D X 28"H LAMINATE: STANDARD TAG: ROOM 122	\$448.00	\$448.00
(1)	ARTICULATING KEYBOARDS TRAYS W/PALM REST TAG: ROOM 122	\$343.00	\$343.00
(1)	FREESTANDING IN/OUT 2-LEVEL #DEF582704 PAPER TRAY. TAG: ROOM 122	\$29.99	\$29.99
(1)	FREESTANDING DIAGONAL TRAY #UNV08113 3-SLOTS TAG: ROOM 122	\$12.50	\$12.50
(1)	GLOBAL MULTI-TILTER SCALE TASK #3022-3 MID-BACKL CHAIR W/ADJ ARMS PNEUMATIC HT ADJ, TILT-TNESION CONTROL WATERFALL SEAT, CONTOURED SEAT, BACK HT ADJUSTMENT, LUMBAR SURPPORT BACK ANGLE, FORWARD TILT LOCK, 5-STAR BASE UPH: GRADE III PATTERN: TBD BASE: BLACK TAG: ROOM 122	\$392.00	\$392.00
(1)	GLOBAL GUEST SIDE CHAIRS W/ARMS #6900 – METAL FRAME, 4-LEGS UPH: GRADE III PATTERN: TBD TAG: ROOM 122	\$172.00	\$172.00

<u>QTY</u>	<u>DESCRIPTION</u>	<u>UNIT</u>	<u>EXT</u>
(3)	GLOBAL ADAPTABILITIES 4-DRAWER #A2036S4 HP LAMINATE LATERAL FILE W/LOCK DIM: 36"W X 20"D X 49.5"H LAMINATE: STANDARD – TBD TAG: ROOM 122	\$940.00	\$2,820.00
(1)	GLOBAL ADAPTABILITIES HP LAMINATE #A3072S4R SINGLE PEDESTAL DESK, RIGHT W/LOCK, BBFPED, W/FULL MODESTY PANEL DIM: 72"W X 30"D X 29"H HP LAMINATE: STANDARD – TBD TAG: ROOM 151	\$744.00	\$744.00
(1)	GLOBAL ADAPTABILITIES CENTER DRAWER #W1624PDR LAMINATE: STANDARD – TBD TAG: ROOM 151	\$116.00	\$116.00
(1)	GLOBAL ADAPTABILITIES FLUSH BRIDGE #A2448 – W/FULL MODESTY PANEL, GROMMET DIM: 48"W X 24"D X 29"H HP LAMINATE: STANDARD – TBD TAG: ROOM 151	\$199.00	4199.00
(1)	GLOBAL ADAPTABILITIES SINGLE PED CREDENZA, LEFT W/GROMMET FULL MODESTY PANEL DIM: 72"W X 24"D X 29"H HP LAMINATE: STANDARD – TBD TAG: ROOM 151	\$704.00	\$704.00
(1)	GLOBAL ADAPTABILITIES HUTCH W/O DOORS #A72HOCB W/TACK BOARD AND TASK LIGHT DIM: 72:W X 15"D X 36"H LAMINATE: STANDARD – TBD TAG: ROOM 151	\$399.00	\$399.00
(1)	GREAT OPENEINGS 48"W TASK LIGHT #VT48BK COLOR: BLACK TAG: ROOM 151	\$125.00	\$125.00
(1)	GLOBAL ADAPTABILITIES TACK-BOARD #ATB7016 UPH: GRADE III PATTERN: TBD TAG: ROOM 151	\$134.00	\$134.00



<u>QTY</u>	<u>DESCRIPTION</u>	<u>UNIT</u>	<u>EXT</u>
(1)	ARTICULATING KEYBOARDS TRAYS W/PALM REST TAG: ROOM 151	\$343.00	\$343.00
(1)	FREESTANDING IN/OUT 2-LEVEL #DEF582704 PAPER TRAY. TAG: ROOM 151	\$29.99	\$29.99
(1)	FREESTANDING DIAGONAL TRAY #UNV08113 3-SLOTS TAG: ROOM 151	\$12.50	\$12.50
(1)	GLOBAL ROUND TABLE W/CROSS BASE #G42CHBN DIM: 42"DIA X 29"H LAMINATE: STANDARD – TBD BASE: TBD TAG: ROOM 151	\$258.00	\$258.00
(1)	GLOBAL MULTI-TILTER SCALE TASK #3022-3 MID-BACKL CHAIR W/ADJ ARMS PNEUMATIC HT ADJ, TILT-TNESION CONTROL WATERFALL SEAT, CONTOURED SEAT, BACK HT ADJUSTMENT, LUMBAR SURPPOINT BACK ANGLE, FORWARD TILT LOCK, 5-STAR BASE UPH: GRADE III PATTERN: TBD BASE: BLACK TAG: ROOM 151	\$392.00	\$392.00
(2)	GLOBAL GUEST SIDE CHAIRS W/ARMS #6900 – METAL FRAME, 4-LEGS UPH: GRADE III PATTERN: TBD TAG: ROOM 151	\$172.00	\$344.00
(2)	GLOBAL GUEST SIDE CHAIRS W/ARMS #6900C – METAL FRAME, 4-LEGS W/CASTER'S UPH: GRADE III PATTERN: TBD TAG: ROOM 151	\$195.00	\$390.00
(1)	GLOBAL ADAPTABILITIES 4-DRAWER #A2036S4 HP LAMINATE LATERAL FILE W/LOCK DIM: 36"W X 20"D X 49.5"H HP LAMINATE: STANDARD – TBD TAG: MISCELLANEOUS ITEMS	\$940.00	\$940.00

<u>QTY</u>	<u>DESCRIPTION</u>	<u>UNIT</u>	<u>EXT</u>
(1)	GLOBAL ADAPTABILITIES OPEN BOOKCASE #ABC48 W/THREE ADJUSTABLE SHELVES DIM: 36"W X 12"D X 48"H LAMINATE: STANDARD – TBD TAG: MISCELLANEOUS ITEMS	\$293.00	\$293.00
(1)	GLOBAL ROUND TABLE W/DRUM BASE #G42CZBN DIM: 42" DIA X 29"H LAMINATE: STANDARD – TBD TAG: MISCELLANEOUS ITEMS	\$279.00	\$279.00
(1)	GLOBAL CONFERENCE TABLE #GCT7RZBN W/2-DRUM BASES DIM: 84"W X 44"D X 29"H LAMINATE: STANDARD – TBD TAG: CONF ROOM 108	\$573.00	\$573.00
(8)	GLOBAL MULTI-TILTER SCALE TASK #3022-3 MID-BACKL CHAIR W/ADJ ARMS PNEUMATIC HT ADJ, TILT-TNESION CONTROL WATERFALL SEAT, CONTOURED SEAT, BACK HT ADJUSTMENT, LUMBAR SURPPORT BACK ANGLE, FORWARD TILT LOCK, 5-STAR BASE UPH: GRADE III PATTERN: TBD BASE: BLACK TAG: CONF ROOM 108	\$392.00	\$3,136.00
(4)	GLOBAL GUEST SIDE STACK CHAIR'S #6901 – METAL FRAME, 4-LEGS , W/O ARMS UPH: GRADE III PATTERN: TBD TAG: CONF ROOM 108	\$155.00	\$620.00
(1)	GLOBAL DBL DOOR STORAGE CABINET #Z36LASH DIM: 36"W X 24"D X 40"H HP LAMINATE: STANDARD – TBD TAG: MISCELLANEOUS ITEMS	\$502.00	\$502.00

<u>QTY</u>	<u>DESCRIPTION</u>	<u>UNIT</u>	<u>EXT</u>
(1)	GLOBAL VISUAL BOARD #AVB4848 WHITE BOARD, TWO SIDE OPENING DOORS, CORK BOARD ON RIGHT, 50 SHEET PAD ON LEFT, MAKER BOARD CAN BE USED FOR PROJECTIONS. SET OF 4-MARKERS AND ERASER TAG: MISCELLANEOUS ITEMS	\$545.00	\$545.00
(1)	GLOBAL CONFERENCE TABLE #GRT8WZBN RACETRACK TOP W/2-DRUM BASES DIM: 96"W X 48"D X 29"H LAMINATE: STANDARD – TBD TAG: CONF ROOM 110	\$573.00	\$573.00
(8)	GLOBAL GUEST SIDE CHAIRS W/ARMS #6900C – METAL FRAME, 4-LEGS W/CASTERS UPH: GRADE III PATTERN: TBD TAG: CONF ROOM 110	\$195.00	\$1,560.00
(4)	GLOBAL GUEST SIDE STACK CHAIR'S #6901 – METAL FRAME, 4-LEGS , W/O ARMS UPH: GRADE III PATTERN: TBD TAG: CONF ROOM 110	\$159.00	\$636.00
(1)	GLOBAL VISUAL BOARD #AVB4848 WHITE BOARD, TWO SIDE OPENING DOORS, CORK BOARD ON RIGHT, 50 SHEET PAD ON LEFT, MAKER BOARD CAN BE USED FOR PROJECTIONS. SET OF 4-MARKERS AND ERASER TAG: MISCELLANEOUS ITEMS	\$545.00	\$545.00
(20)	SURFACE WORKS LAMINATE TABLE #TTEDR.2.2460 EBR, VINYL EDGE STEEL BASE W/LOCKING CASTERS DIM: 60"W X 24"D X 29"H LAMINATE: STANDARD –TBD TAG: CONF ROOM 142	\$386.00	\$7,720.00

<u>QTY</u>	<u>DESCRIPTION</u>	<u>UNIT</u>	<u>EXT</u>
(40)	GLOBAL GUEST SIDE CHAIRS W/ARMS #6900C – METAL FRAME, 4-LEGS W/CASTERS UPH: GRADE III PATTERN: TBD TAG: CONF ROOM 142	\$195.00	\$7,800.00
(1)	DISPLAY/INFORMATION BOARDS		
(1)	6-H OPEN METAL SHELVING /GREY #TNN-ESPG2436MGY HEAVY DUTY DIM: 36"W X 12"D X 75"H	\$130.00	\$130.00
(3)	SURFACE WORKS LAMINATE TBL TOP #TTE.F.3672EBR W/METAL T-BASE LAMINATE: STANDARD – TBD TAG: BREAKROOM 146	\$354.00	\$1,062.00
(12)	OFFICESTAR/WORK SMART STACK CHAIRS PLASTIC SEAT AND BACK W/O ARMS METAL CHROME BASE COLOR: TBD (CHOOICE OF 4-COLORS) TAG: BREAKROOM 146	\$83.00	\$996.00
(44)	SIT ON IT HARD SHELL STACK CHAIR W/O ARMS, CHROME BASE LEGS W/GANGING CLIPS COLOR: STANDARD –TBD TAG: LOBBY AREA	\$88.00	\$3,872.00
(1)	SURFACE WORKS TABLE W/T-LEGS #TTER6030EBR – W/LOCKING CASTERS DIM: 60"W X 30"D LAMINATE: STANDARD – TBD TAG: LOBBY AREA	\$350.00	\$350.00
(1)	GLOBAL ADAPTABILITIES FREESTANDING #A2460T - TABLE DESK W/GROMMET HP LAMINATE: STANDARD – TBD TAG: VIDEO ROOM 107	\$391.00	\$391.00
(1)	GLOBAL ADAPTABILITIES BBF PEDESTAL #AFPBBF22 W/LOCK FOR ABOVE TABLE DESK DIM: 16"W X 22"D X 28"H LAMINATE: STANDARD – TBD TAG: VIDEO ROOM 107	\$366.00	\$366.00

<u>QTY</u>	<u>DESCRIPTION</u>	<u>UNIT</u>	<u>EXT</u>
(1)	GLOBAL MULTI-TILTER SCALE TASK #3022-3 MID-BACKL CHAIR W/ADJ ARMS PNEUMATIC HT ADJ, TILT-TNESION CONTROL WATERFALL SEAT, CONTOURED SEAT, BACK HT ADJUSTMENT, LUMBAR SURPPOINT BACK ANGLE, FORWARD TILT LOCK, 5-STAR BASE UPH: GRADE III PATTERN: TBD BASE: BLACK TAG: VIDEO ROOM 107	\$392.00	\$392.00
(1)	GLOBAL ADAPTABILITIES 4-H BOOKCASE #ABC48 – OPEN, CLOSED BACK W/2-ADJUSTABLE SHELVES LAMINATE: STANDARD – TBD TAG: MICELLANOUS ITEMS	\$293.00	\$293.00
(1)	GLOBAL ROUND TABLE #GCAR48BN – W/METAL COLUMN “X” BASE LAMINATE: STANDARD – TBD TAG: FAMILY ROOM 105	\$263.00	\$263.00
(1)	GLOBAL END TABLE W/H-LEGS #H24 DIM: 24”W X 24”D X 16”H LAMINATE: STANDARD – TBD TAG: FAMILY ROOM 105	\$102.00	\$102.00
(1)	GLOBAL JARVIS 3-SEAT SOFA W/ARMS #3494 W/4-LEGS, NO CASTERS DIM: 75”W X 29”D X 31”H UPH: GRADE 4 – VINYL COLOR: TBD TAG: SEATING	\$1,183.00	\$1,183.00
(1)	GLOBAL JARVIS LOUNGE CHAIR #3491 W/ARMS, 4-LEGS, NO CASTERS DIM: 32”W X 29”D X 31”H UPH: GRADE 4-VINYL COLOR: TBD TAG: SEATING	\$686.00	\$686.00
(4)	SIT ON IT HARD SHELL STACK CHAIR W/O ARMS, CHROME BASE LEGS COLOR: STANDARD –TBD TAG: SEATING	\$82.00	\$328.00

<u>QTY</u>	<u>DESCRIPTION</u>	<u>UNIT</u>	<u>EXT</u>
(1)	GLOBAL ADAPTABILITIES 4-H BOOKCASE #ABC48 – OPEN, CLOSED BACK W/2-ADJUSTABLE SHELVES LAMINATE: STANDARD – TBD	\$293.00	\$293.00
(2)	6-HIGH 36"W X 12"D OPEN METAL SHELVING #TNNESP61236MGY UNIT - HEAVY DUTY DIM: 36"E X 12"D X 75"H TAG: STORAGE ROOM 148	\$130.00	\$260.00
(6)	6-HIGH 36"W X 24"D OPEN METAL SHELVING #TNNESP62436MJY UNIT – HEAVY DUTY HEAVY DUTY – 72"H TAG: STORAGE ROOM 148	\$200.00	\$1,200.00
(1)	LABOR CHARGES	\$4,450.00	\$4,450.00
(1)	GRAND TOTAL	\$301,153.00	\$301,153.00

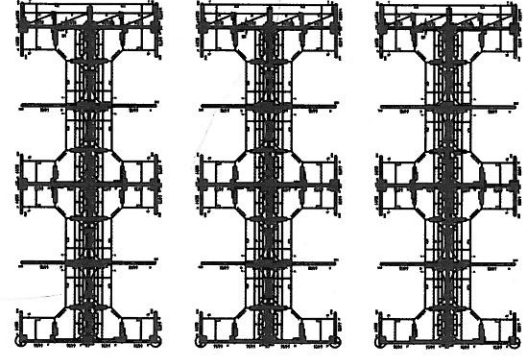
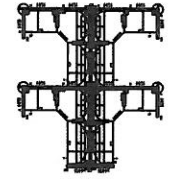
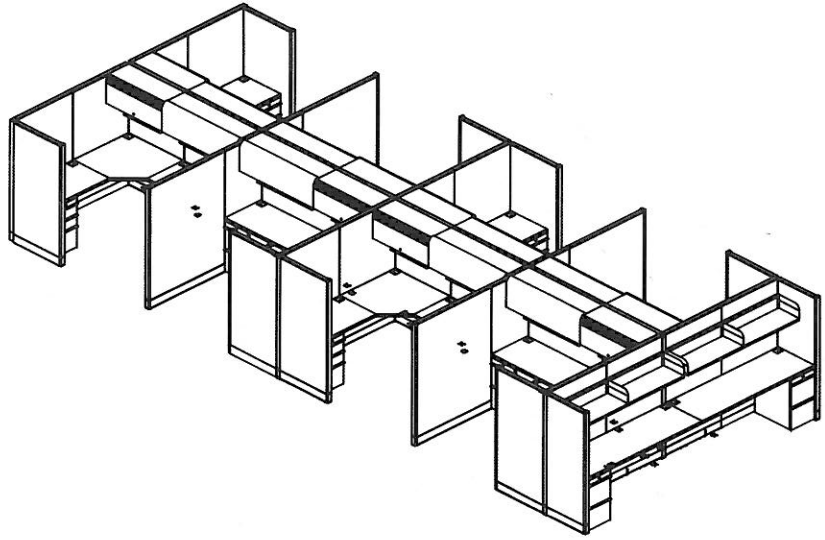
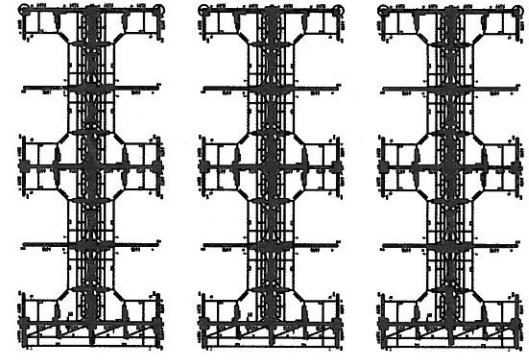
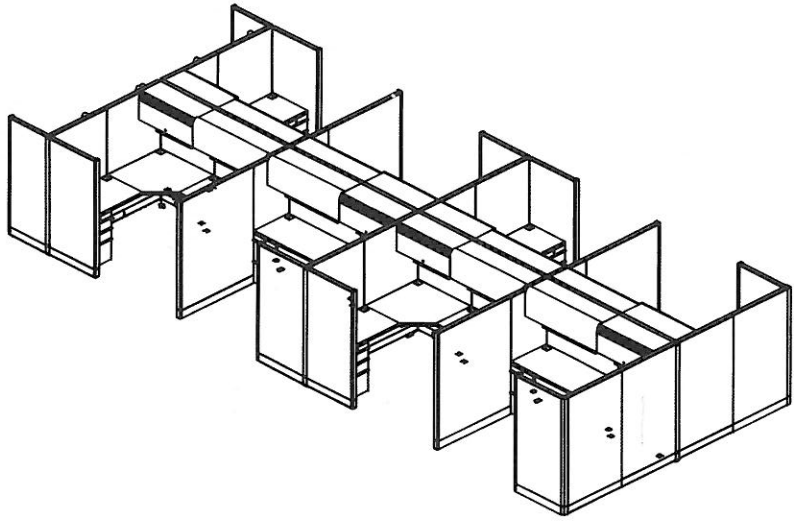

Designer: SAV  
 Date: 10.28.13  
 Scale: NTS  
 Approved By:

Client: Nicholas County DHHR

**Boomerang**  
 9155 River Road  
 Pennsauken, NJ 08110  
 856-582-0100 Tel 856-582-0104 Fax







**Work Surfaces**

Description	QTY	MNFTR	Part No.	Catalog#	Page	Location/Rooms	Unit Price	EXT. Price
24" d x 36"w laminate work surface	48							\$ -
24" d x 36"w laminate corner work surface	48							\$ -
24" d x 48"w laminate work surface	48							\$ -
36" w steel flipper door unit w/lock	48							\$ -
48" w steel flipper door unit w/lock	48							\$ -
24" d f/f pedestal must be full height to attach to work surface w/lock.	48							\$ -
24" d b/b/f pedestal must be full height to attach to work surface w/lock.	48							\$ -
11" h x 36" w tack board	48							\$ -
30" w task light - must be within 6" of the width of the cabinet	48							\$ -
42" w task light - must be within 6" of the width of the cabinet.	48							\$ -
Keyboard tray fully adjustable, with mouse pad that can be moved to either left or right side of keyboard tray, includes palm support, no knob or lever needed for height adjustment, 6" of height adjustment, negative and positive tilt with 360 degree swivel.	48							\$ -
48" w toolbar to include: One horizontal in/out basket with one divider to allow for 2 levels of storage One (1) vertical to consist of 3 slots. These are to be located on the 48" wide panel.	48							\$ -
Subtotal								\$ -

*See attached*

*Proposal*

**Seating**

Description	QTY	MNFTR	Part No.	Catalog#	Page	Location/Rooms	Unit Price	EXT. Price
Task chairs - standard pneumatic height, tilt, swivel, features metal frame with height adjustable arms, 5 star base with casters, mid back design, adjustable lumbar, upholstered in fabric.	38	Global	5336-5		127	Luk Station 123/138	273,-	\$ 10,374,-
Big and Tall Chairs with same features as standard task chair but must hold minimum weight of 350 lbs.	10	Global	T554S1-3		295	Luk Station	333,-	\$ 3,330,-
Subtotal								\$ 13,704,-

**Miscellaneous Items**

Description	QTY	MNFTR	Part No.	Catalog#	Page	Location/Rooms	Unit Price	EXT. Price
Coat hooks	48					Included in Luk Station pricing		\$ -
Subtotal								\$ -

**Section Total:** \$ -





24"d x 30"w x 28"h, laminate.									\$ -
								Subtotal	\$ -

Section Total: \$ -

**Section 3.2.5 - There are 10 Interview Rooms:**

(Rooms 126, 127, 128, 129, 130, 131, 132, 133, 134 and 135)

**Private Offices**

Description	QTY	MNFTR	Part No.	Catalog#	Page	Location/Rooms	Unit Price	EXT. Price	
Desk - General Specifications:								\$ -	
Outside and surface panels are made from minimum 1" thick minimum 45 lbs. density particle board and covered on both sides with high performance thermally fused laminate. File drawers have full extension steel ball bearing slides, box drawers use minimum 3/4 extension steel ball bearing slides. Drawers and end panels are edge banded on all four sides to protect clothing and the floor covering. locks are standard. Drawers are open with side pulls. Full leg end panels and modesty panel.								\$ -	
Desk 48" l x 30" w x 29" h laminate top, full laminate desk <b>no steel</b> , single pedestal b/b/f free standing design.	10	Global						\$ -	
			# A3048T	Desking	22	126-135	\$408.-	\$ 4080.-	
			# AFPBR28		12	↓	\$ 381.-	\$ 3810.-	
Keyboard tray fully adjustable, with mouse pad that can be moved to either left or right side of keyboard tray, includes palm support, no knob or lever needed for height adjustment, 6" of height adjustment, negative and positive tilt with 360 degree swivel.	10	Knoll						\$ -	
						N/A	\$343.-	\$ 3430.-	
								\$ -	
								\$ -	
Tack board - 36" w x 11" h attached to wall.	10	Global	# ATP3416			33 126-135	84.-	\$ 840.-	
								Subtotal	\$ -

**Seating**

Description	QTY	MNFTR	Part No.	Catalog#	Page	Location/Rooms	Unit Price	EXT. Price	
Task chairs: standard pneumatic height, tilt, swivel features metal frame with height adjustable arms, 5 star base casters, mid back design, adjustable lumbar, upholstered in fabric	10	Office Star	# 33167			30 126-135	169.-	\$ 1690.-	
								\$ -	
								\$ -	
Guest chairs - metal frame no arms, 4 legs stationary without casters molded poly shell no upholstery.	20	Global	# 6900			217 ↓	172.-	\$ 3440.-	
								Subtotal	\$ -

Section Total: \$ -

**3.2.5A Printer Table (Outside Room 125)**

Description	QTY	MNFTR	Part No.	Catalog#	Page	Location/Rooms	Unit Price	EXT. Price
18" d x 48" w table, laminate top with steel base and 4 legs on locking casters	1	Surface Works	# TTEDR-1818ERR			28 125	497.-	\$ 497.-

Subtotal	\$ -
----------	------

Section Total: \$ -

**Section 3.2.6 - 13 Enclosed Private Office**  
**(Room 109, 111, 112, 113, 114, 115, 116, 117, 118, 119, 120, 121 and 150)**

**Private Offices**

Description	QTY	MNFTR	Part No.	Catalog#	Page	Location/Rooms	Unit Price	EXT. Price
Desk - General Specifications: Outside and surface panels are made from minimum 1" thick minimum 45 lbs. density particle board and covered on both sides with high performance thermally fused laminate. File drawers have full extension steel ball bearing slides, box drawers use minimum 3/4 extension steel ball bearing slides. Drawers and end panels are edge banded on all four sides to protect clothing and the floor covering. locks are standard. Drawers are open with side pulls. Full leg end panels and modesty panel.								\$ -
36" x 72" d peninsula desk	13	Global *			26	D.	54.00	652.00
48" w return with f/f full height pedestal	13				26	B.	53.00	696.00
48" w over the desk w/tack board	13				32	H.	27.50	357.50
36" w task light	13				33	T.B	8.70	113.10
24" full height, laminate b/b/f pedestal mobile with casters.	13					Til	11.60	150.80
Keyboard tray fully adjustable, with mouse pad that can be moved to either left or right side of keyboard tray, includes palm support, no knob or lever needed for height adjustment, 6" of height adjustment, negative and positive tilt with 360 degree swivel.	13					MP	44.80	582.40
						KIPD	34.30	343.00
Freestanding paper tray to include: Horizontal In/Out Tray with one divider to allow for 2 levels of storage	13	United		ADER:582704		109,111,121,150	\$29.99	389.87
Freestanding diagonal tray to consist of 3 slots	13					150	\$12.50	162.50
Subtotal								\$ -

**Seating**

Description	QTY	MNFTR	Part No.	Catalog#	Page	Location/Rooms	Unit Price	EXT. Price
Task chairs: standard pneumatic height, tilt, swivel features metal frame with height adjustable arms, 5 star base casters, mid back design, adjustable lumbar, upholstered in fabric	13	Global		*3022-3	112	109,111,121,150	\$39.20	509.60
Guest chairs - metal frame w/arms, 4 legs without casters upholstered in fabric	26	Global		*6900	217		\$17.20	447.20
Subtotal								\$ -

77

Miscellaneous Items

Description	QTY	MNFTR	Part No.	Catalog#	Page	Location/Rooms	Unit Price	EXT. Price
36" w x 4 high laminate lateral file w/lock	13	Celebral	# A203684		38	109, 111-121	\$940.	\$12,220.
Bookcase 12" d x 36" w x 48" h 4 high laminate with 3 adjustable shelves in 1" increments must have finished backs.	13	Celebral	# A203684			\$180	\$233.	\$3809.
					40	✓		
Subtotal								\$ -

Section Total: \$ -

Section 3.2.6A - Storage Area located outside Room 109

Miscellaneous Items

Description	QTY	MNFTR	Part No.	Catalog#	Page	Location/Rooms	Unit Price	EXT. Price
Steel Storage Cabinet: 5 high, 42" w with hinged doors, lock and adjustable glides	3	Celebral	# 93225R1H		530	109	\$651	\$1953.
Subtotal								\$ -

Section Total: \$0.00

Section 3.2.7 - There are 1 Enclosed Office: (Room 122)

Private Offices

Description	QTY	MNFTR	Part No.	Catalog#	Page	Location/Rooms	Unit Price	EXT. Price
Free standing design:						122		\$ -
Desk - General Specifications: Outside and surface panels are made from minimum 1" thick minimum 45 lbs. density particle board and covered on both sides with high performance thermally fused laminate. File drawers have full extension steel ball bearing slides, box drawers use minimum 3/4 extension steel ball bearing slides. Drawers and end panels are edge banded on all four sides to protect clothing and the floor covering. locks are standard. Drawers are open with side pulls. Full leg end panels and modesty panel.		Celebral						\$ -
36" x 72" d peninsula desk	1						\$504.	\$504.
48" w return with full height pedestal	1						\$536.	\$536.
48" w over the desk w/tack board	1						\$275.	\$275.
36" w task light	1						\$89.	\$89.
24" full height, laminate b/b/f pedestal mobile with casters.	1						\$116.	\$116.
Keyboard tray fully adjustable, with mouse pad that can be moved to either left or right side of keyboard tray, includes palm support, no knob or lever needed for height adjustment, 6" of height adjustment, negative and positive tilt with 360 degree swivel.	1						\$448.	\$448.
Freestanding paper tray to include: Horizontal In/Out Tray	1						\$343.	\$343.
							\$2999.	\$2999.

with one divider to allow for 2 levels of storage							\$	-
Freestanding diagonal tray to consist of 3 slots	1		Celebrine				\$ 12.50	\$ 12.50
							Subtotal	\$ -

**Seating**

Description	QTY	MNFR	Part No.	Catalog#	Page	Location/Rooms	Unit Price	EXT. Price
Task chairs: standard pneumatic height, tilt, swivel features metal frame with height adjustable arms, 5 star base casters, mid back design, adjustable lumbar, upholstered in fabric	1	Global	# 3022	3		112 122	392.-	\$ 392.-
<i>Seating</i>								
Guest chairs - metal frame with arms, 4 legs without casters upholstered in fabric	2	Global	# 6900			217 122	172.-	\$ 172.-
							Subtotal	\$ -

**Miscellaneous Items**

Description	QTY	MNFR	Part No.	Catalog#	Page	Location/Rooms	Unit Price	EXT. Price
36" w x 4 high laminate lateral file w/lock	3	Global	# A203654		38	122	940.-	\$ 2820.-
							Subtotal	\$ -

**Section Total:** \$ -

**Section 3.2.8 - There is 1 enclosed office: (Room 151)**

**Private Offices**

Description	QTY	MNFR	Part No.	Catalog#	Page	Location/Rooms	Unit Price	EXT. Price
Free standing design:								\$ -
Desk - General Specifications:								\$ -
Outside and surface panels are made from minimum 1" thick minimum 45 lbs. density particle board and covered on both sides with high performance thermally fused laminate. File drawers have full extension steel ball bearing slides, box drawers use minimum 3/4 extension steel ball bearing slides. Drawers and end panels are edge banded on all four sides to protect clothing and the floor covering.								\$ -
locks are standard. Drawers are open with side pulls. Full leg end panels and modesty panel.		Global						\$ -
72" w x 30" d peninsula desk	1	#	A307254R		13	151	744.-	\$ 744.-
Center drawer laminate 18"d x 20"w x 3"h	1	#	W16247DR		516	"	116.-	\$ 116.-
48" w x 24" d bridge	1	#	A2448		15	"	199.-	\$ 199.-
72" w x 24" d single pedestal credenza	1	#	A247254L		16	"	704.-	\$ 704.-
48" w task light	1	#	VT48PX			"	125.-	\$ 125.-
21"h x 72"w Tack board, upholstered in fabric	1	Global	# ATB706		33	"	134.-	\$ 134.-
Keyboard tray fully adjustable, with mouse pad that can be moved to either left or right side of keyboard tray, includes palm support, no knob or lever needed for height adjustment, 6" of	1		Kneu		-	151	343	\$ 343.-

*Great openings*

height adjustment, negative and positive tilt with 360 degree swivel.							\$	-
Freestanding paper tray to include: Horizontal In/Out Tray with one divider to allow for 2 levels of storage	2	United	#DEF582707	151		\$299.98	\$	599.98
Freestanding diagonal tray to consist of 3 slots	1	United	#UNV08113			12.49	\$	12.49
42" round laminate table with one 29"h laminate cross base	1	Global	#G42CABN	151		258.-	\$	258.-
Subtotal							\$	-

**Seating**

Description	QTY	MNFR	Part No.	Catalog#	Page	Location/Rooms	Unit Price	EXT. Price
Task chairs: standard pneumatic height, tilt, swivel features metal frame with height adjustable arms, 5 star base casters, mid back design, adjustable lumbar, upholstered in fabric	1	Global	#3022.3		409	151	864.-	\$ 864.-
Guest chairs - metal frame with arms, 4 legs without casters upholstered in fabric	2	Global	#6900		217		172.-	\$ 344.-
Side chairs - metal frame with arms, 4 legs with casters and upholstered in fabric	2	Global	#6900C		217		195.-	\$ 390.-
Subtotal							\$	-

**Miscellaneous Items**

Description	QTY	MNFR	Part No.	Catalog#	Page	Location/Rooms	Unit Price	EXT. Price
36" w x 4 high laminate lateral file w/lock	1	Global	#A2036SH		38	Misc.	940.-	\$ 940.-
72"w Hutch, with locking doors, one fixed shelf and one fixed divider, 15"d x 72"w x 42"h, laminate	1	Global	#A72HOCB		30	"	399.-	\$ 399.-
Bookcase 12" d x 36" w x 48" h 4 high laminate with 3 adjustable shelves in 1" increments must have finished backs.	1	Global	#A3648		40	"	293.-	\$ 293.-
42" round laminate table with one round laminate pedestal base	1	Global	#G42C23N		409	"	279.-	\$ 279.-
Subtotal							\$	-

Section Total: \$ -

**Section 3.2.9 - There is one conference room (Room 108)**

**Tables**

Description	QTY	MNFR	Part No.	Catalog#	Page	Location/Rooms	Unit Price	EXT. Price
Conference table: 84"l x 48" w laminate top and two round laminate pedestal bases	1	Global	#GCT7R23N		413	108	573.-	\$ 573.-
Subtotal							\$	-

**Seating**

Description	QTY	MNFR	Part No.	Catalog#	Page	Location/Rooms	Unit Price	EXT. Price
Task chairs: standard pneumatic height, tilt, swivel features metal frame with height adjustable arms, 5 star base casters, mid back	8	Global	#3022.3		112	108	392.-	\$ 3136.-



design, adjustable lumbar, upholstered in fabric						217	108	158.-	\$ 158.-
Stacking Side Chairs, 4 legs, no arms and	4		Global						\$ -
upholstered in fabric			# 6901						\$ -
Subtotal									\$ -

**Miscellaneous Items**

Description	QTY	MNFTR	Part No.	Catalog#	Page	Location/Rooms	Unit Price	EXT. Price	
Laminate Storage Cabinet with doors, locking 24"d x 36"w x 40"h	1		Global	236245H	192	108	502.-	\$ 502.-	
Visual board to consist of: white board, two side opening doors, cork board on right door and 50 sheet writing pad on left door. Marker board can also be used for projections.	1		Global	AVB 4848	95	Miscel.	545.-	\$ 545.-	
Set of 4 dry markers and eraser included with board.						"		\$ -	
Subtotal									\$ -

Section Total: \$ -

**Section 3.2.10 - There is one conference room (Room 110)**

**Tables**

Description	QTY	MNFTR	Part No.	Catalog#	Page	Location/Rooms	Unit Price	EXT. Price	
Conference table: 96"l x 42" w laminate top and two round laminate pedestal bases	1		Global		413	110	573.-	\$ 573.-	
Subtotal									\$ -

**Seating**

Description	QTY	MNFTR	Part No.	Catalog#	Page	Location/Rooms	Unit Price	EXT. Price	
Side Chairs: metal frame with arms, 4 legs with casters and upholstered in fabric	8		Global	# 6900c	217	110	195.-	\$ 1560.-	
Stacking Side Chairs, 4 legs, no arms and upholstered in fabric	4		Global	# 6901	217	110	159.-	\$ 636.-	
Subtotal									\$ -

**Miscellaneous Items**

Description	QTY	MNFTR	Part No.	Catalog#	Page	Location/Rooms	Unit Price	EXT. Price	
Visual board to consist of: white board, two side opening doors, cork board on right door and 50 sheet writing pad on left door. Marker board can also be used for projections.	1		Global		415	Miscel.	545.-	\$ 545.-	
Set of 4 dry markers and eraser included with board.				# AVB 4848				\$ -	
Subtotal									\$ -

Section Total: \$ -

**Section 3.2.11 - There is one large conference room (Room 142)**

**Tables**

Description	QTY	MNFTR	Part No.	Catalog#	Page	Location/Rooms	Unit Price	EXT. Price	
24"d x 60"w laminate tops with 29"h steel base and 4 legs on locking casters	20		S. Wood	works	28	142	386.-	\$ 7720.-	
Subtotal									\$ -

**Seating**

Description	QTY	MNFTR	Part No.	Catalog#	Page	Location/Rooms	Unit Price	EXT. Price
Side Chairs: metal frame with arms, 4 legs with casters, upholstered in fabric	40		Global	#69002	217	142	195.00	\$ 7800.00
Subtotal								\$ -

**Miscellaneous Items**

Description	QTY	MNFTR	Part No.	Catalog#	Page	Location/Rooms	Unit Price	EXT. Price
Display/Information boards consisting of: 12'w x 42" h laminate writable surface	2							\$ -
Information boards are 0.64" (16mm) thick with one usable side and 1mm bright white edgeband. Safety interlock prevents dislodgement from horizontal wall rail.								\$ -
12' of upper rails	2							\$ -
12' of lower rails to be attached to the wall horizontally to accommodate above boards. Lower rails should also function as a marker tray.	2							\$ -
6 high 36" w x 12" d open style shelving with metal shelves heavy duty, 20 gauge steel, 1000lb max load per shelf	4		United #TANES	61236461		148	130.00	\$ 520.00
Subtotal								\$ -

Section Total: \$ -

**Section 3.2.12 - The break room (Room 146)**

**Tables**

Description	QTY	MNFTR	Part No.	Catalog#	Page	Location/Rooms	Unit Price	EXT. Price
36" d x 72" w laminate tops with two 29" h metal column with "T" legs	3		Surface works		22	146	354.00	\$ 1062.00
Subtotal								\$ -

**Seating**

Description	QTY	MNFTR	Part No.	Catalog#	Page	Location/Rooms	Unit Price	EXT. Price
Chairs: molded poly shell no upholstery metal frame without arms, 4 legs, stationary	12				68	146	83.00	\$ 996.00
Subtotal								\$ -

Office Star  
works smart

Section Total: \$ -





Section 3.2.17 - Janitor's Room (Room 141)

Section Total: \$ -

Miscellaneous Items

Description	QTY	MNFTR	Part No.	Catalog#	Page	Location/Rooms	Unit Price	EXT. Price
Shelves								\$ -
6 high 36" w x 12" d open style shelving with metal shelves	2							\$ -
heavy duty, 20 gauge steel, 1000 lb. max load per shelf								\$ -
								\$ -
Subtotal								\$ -

Section Total: \$ -

GRAND TOTAL COST: \$ 301,153.17

VENDOR NAME: Aarons Products

ADDRESS: 1041 8th Ave

Huntington, WV 25701

E-MAIL: Kathy.Santos@aaronsproducts.com

FAX #: 304.525.3069

PHONE #: 304.522.7022

SIGNATURE: J. Santos

DATE: 11/12/13

Labor Included  
(\$4,450.17)

# State of West Virginia VENDOR PREFERENCE CERTIFICATE

Certification and application\* is hereby made for Preference in accordance with **West Virginia Code**, §5A-3-37. (Does not apply to construction contracts). **West Virginia Code**, §5A-3-37, provides an opportunity for qualifying vendors to request (at the time of bid) preference for their residency status. Such preference is an evaluation method only and will be applied only to the cost bid in accordance with the **West Virginia Code**. This certificate for application is to be used to request such preference. The Purchasing Division will make the determination of the Resident Vendor Preference, if applicable.

**1. Application is made for 2.5% resident vendor preference for the reason checked:**

- Bidder is an individual resident vendor and has resided continuously in West Virginia for four (4) years immediately preceding the date of this certification; **or**,
- Bidder is a partnership, association or corporation resident vendor and has maintained its headquarters or principal place of business continuously in West Virginia for four (4) years immediately preceding the date of this certification; **or** 80% of the ownership interest of Bidder is held by another individual, partnership, association or corporation resident vendor who has maintained its headquarters or principal place of business continuously in West Virginia for four (4) years immediately preceding the date of this certification; **or**,
- Bidder is a nonresident vendor which has an affiliate or subsidiary which employs a minimum of one hundred state residents and which has maintained its headquarters or principal place of business within West Virginia continuously for the four (4) years immediately preceding the date of this certification; **or**,

**2. Application is made for 2.5% resident vendor preference for the reason checked:**

- Bidder is a resident vendor who certifies that, during the life of the contract, on average at least 75% of the employees working on the project being bid are residents of West Virginia who have resided in the state continuously for the two years immediately preceding submission of this bid; **or**,

**3. Application is made for 2.5% resident vendor preference for the reason checked:**

- Bidder is a nonresident vendor employing a minimum of one hundred state residents or is a nonresident vendor with an affiliate or subsidiary which maintains its headquarters or principal place of business within West Virginia employing a minimum of one hundred state residents who certifies that, during the life of the contract, on average at least 75% of the employees or Bidder's affiliate's or subsidiary's employees are residents of West Virginia who have resided in the state continuously for the two years immediately preceding submission of this bid; **or**,

~~**4. Application is made for 5% resident vendor preference for the reason checked:**~~

- ~~Bidder meets either the requirement of both subdivisions (1) and (2) or subdivision (1) and (3) as stated above; **or**,~~

**5. Application is made for 3.5% resident vendor preference who is a veteran for the reason checked:**

- Bidder is an individual resident vendor who is a veteran of the United States armed forces, the reserves or the National Guard and has resided in West Virginia continuously for the four years immediately preceding the date on which the bid is submitted; **or**,

**6. Application is made for 3.5% resident vendor preference who is a veteran for the reason checked:**

- Bidder is a resident vendor who is a veteran of the United States armed forces, the reserves or the National Guard, if, for purposes of producing or distributing the commodities or completing the project which is the subject of the vendor's bid and continuously over the entire term of the project, on average at least seventy-five percent of the vendor's employees are residents of West Virginia who have resided in the state continuously for the two immediately preceding years.

**7. Application is made for preference as a non-resident small, women- and minority-owned business, in accordance with West Virginia Code §5A-3-59 and West Virginia Code of State Rules.**

- Bidder has been or expects to be approved prior to contract award by the Purchasing Division as a certified small, women- and minority-owned business.

Bidder understands if the Secretary of Revenue determines that a Bidder receiving preference has failed to continue to meet the requirements for such preference, the Secretary may order the Director of Purchasing to: (a) reject the bid; or (b) assess a penalty against such Bidder in an amount not to exceed 5% of the bid amount and that such penalty will be paid to the contracting agency or deducted from any unpaid balance on the contract or purchase order.

By submission of this certificate, Bidder agrees to disclose any reasonably requested information to the Purchasing Division and authorizes the Department of Revenue to disclose to the Director of Purchasing appropriate information verifying that Bidder has paid the required business taxes, provided that such information does not contain the amounts of taxes paid nor any other information deemed by the Tax Commissioner to be confidential.

**Under penalty of law for false swearing (West Virginia Code, §61-5-3), Bidder hereby certifies that this certificate is true and accurate in all respects; and that if a contract is issued to Bidder and if anything contained within this certificate changes during the term of the contract, Bidder will notify the Purchasing Division in writing immediately.**

Bidder: Aaron's Products

Signed: [Signature] (Kathy Santostefano)

Date: 11/12/13

Title: Business Development MGR

RFQ No. BCF14088

STATE OF WEST VIRGINIA  
Purchasing Division

**PURCHASING AFFIDAVIT**

**MANDATE:** Under W. Va. Code §5A-3-10a, no contract or renewal of any contract may be awarded by the state or any of its political subdivisions to any vendor or prospective vendor when the vendor or prospective vendor or a related party to the vendor or prospective vendor is a debtor and: (1) the debt owed is an amount greater than one thousand dollars in the aggregate; or (2) the debtor is in employer default.

**EXCEPTION:** The prohibition listed above does not apply where a vendor has contested any tax administered pursuant to chapter eleven of the W. Va. Code, workers' compensation premium, permit fee or environmental fee or assessment and the matter has not become final or where the vendor has entered into a payment plan or agreement and the vendor is not in default of any of the provisions of such plan or agreement.

**DEFINITIONS:**

**"Debt"** means any assessment, premium, penalty, fine, tax or other amount of money owed to the state or any of its political subdivisions because of a judgment, fine, permit violation, license assessment, defaulted workers' compensation premium, penalty or other assessment presently delinquent or due and required to be paid to the state or any of its political subdivisions, including any interest or additional penalties accrued thereon.

**"Employer default"** means having an outstanding balance or liability to the old fund or to the uninsured employers' fund or being in policy default, as defined in W. Va. Code § 23-2c-2, failure to maintain mandatory workers' compensation coverage, or failure to fully meet its obligations as a workers' compensation self-insured employer. An employer is not in employer default if it has entered into a repayment agreement with the Insurance Commissioner and remains in compliance with the obligations under the repayment agreement.

**"Related party"** means a party, whether an individual, corporation, partnership, association, limited liability company or any other form or business association or other entity whatsoever, related to any vendor by blood, marriage, ownership or contract through which the party has a relationship of ownership or other interest with the vendor so that the party will actually or by effect receive or control a portion of the benefit, profit or other consideration from performance of a vendor contract with the party receiving an amount that meets or exceed five percent of the total contract amount.

**AFFIRMATION:** By signing this form, the vendor's authorized signer affirms and acknowledges under penalty of law for false swearing (W. Va. Code §61-5-3) that neither vendor nor any related party owe a debt as defined above and that neither vendor nor any related party are in employer default as defined above, unless the debt or employer default is permitted under the exception above.

**WITNESS THE FOLLOWING SIGNATURE:**

Vendor's Name: Aarvix Products

Authorized Signature: [Signature] Date: 11/12/13

State of WV

County of Cabell, to-wit:

Taken, subscribed, and sworn to before me this 12<sup>th</sup> day of November, 2013.

My Commission expires March 15, 2020, 20    .

**AFFIX SEAL HERE**

**NOTARY PUBLIC** [Signature]

*Purchasing Affidavit (Revised 07/01/2012)*



**CERTIFICATION AND SIGNATURE PAGE**

By signing below, I certify that I have reviewed this Solicitation in its entirety; understand the requirements, terms and conditions, and other information contained herein; that I am submitting this bid or proposal for review and consideration; that I am authorized by the bidder to execute this bid or any documents related thereto on bidder's behalf; that I am authorized to bind the bidder in a contractual relationship; and that to the best of my knowledge, the bidder has properly registered with any State agency that may require registration.

Acevia's Products  
(Company)

J. Santolucito  
(Authorized Signature)

J. Santolucito Business Development MGR  
(Representative Name, Title)

304-522-7022 / 304-525-3069  
(Phone Number) (Fax Number)

11/12/13  
(Date)



**ADDENDUM ACKNOWLEDGEMENT FORM**  
**SOLICITATION NO.: BCF14088**

**Instructions:** Please acknowledge receipt of all addenda issued with this solicitation by completing this addendum acknowledgment form. Check the box next to each addendum received and sign below. Failure to acknowledge addenda may result in bid disqualification.

**Acknowledgment:** I hereby acknowledge receipt of the following addenda and have made the necessary revisions to my proposal, plans and/or specification, etc.

**Addendum Numbers Received:**  
(Check the box next to each addendum received)

- |                                     |                |                          |                 |
|-------------------------------------|----------------|--------------------------|-----------------|
| <input checked="" type="checkbox"/> | Addendum No. 1 | <input type="checkbox"/> | Addendum No. 6  |
| <input type="checkbox"/>            | Addendum No. 2 | <input type="checkbox"/> | Addendum No. 7  |
| <input type="checkbox"/>            | Addendum No. 3 | <input type="checkbox"/> | Addendum No. 8  |
| <input type="checkbox"/>            | Addendum No. 4 | <input type="checkbox"/> | Addendum No. 9  |
| <input type="checkbox"/>            | Addendum No. 5 | <input type="checkbox"/> | Addendum No. 10 |

I understand that failure to confirm the receipt of addenda may be cause for rejection of this bid. I further understand that any verbal representation made or assumed to be made during any oral discussion held between Vendor's representatives and any state personnel is not binding. Only the information issued in writing and added to the specifications by an official addendum is binding.

Aaron's Products  
Company

T. Santolano  
Authorized Signature

11/12/13  
Date

NOTE: This addendum acknowledgment should be submitted with the bid to expedite document processing.