



State of West Virginia
 Department of Administration
 Purchasing Division
 2019 Washington Street East
 Post Office Box 50130
 Charleston, WV 25305-0130

Solicitation

NUMBER
 PSC1010

PAGE
 1

ADDRESS CORRESPONDENCE TO ATTENTION OF:
 GUY NISBET
 304-558-8802

REORDER

*709022041 304-925-0305
 WV UNIFORMS INC
 6601 MACCORKLE AVE SE
 CHARLESTON WV 25304

SHIP TO

PUBLIC SERVICE COMMISSION
 OF WEST VIRGINIA
 201 BROOKS STREET
 CHARLESTON, WV
 25301 340-0323

DATE PRINTED
 01/30/2013

BID OPENING DATE: 03/05/2013 BID OPENING TIME 1:30PM

LINE	QUANTITY	UOP	CAT NO	ITEM NUMBER	UNIT PRICE	AMOUNT
0001	1	LS		590-04		
UNIFORMS FOR ENFORCEMENT OFFICERS						
REQUEST FOR SOLICITATION (RFQ)						
THE WEST VIRGINIA PURCHASING DIVISION FOR THE AGENCY, THE WEST VIRGINIA PUBLIC SERVICE COMMISSION (WVPSC), IS SOLICITING BIDS TO PROVIDE AN OPEN-END CONTRACT FOR UNIFORMS AND ACCESSORIES, PER THE ATTACHED BID SPECIFICATIONS AND REQUIREMENTS.						
***** THIS IS THE END OF RFQ PSC1010 ***** TOTAL:						
03/05/13 01:05:20 PM West Virginia Purchasing Division						

SIGNATURE  TELEPHONE 304-925-0305 DATE 03/07/2013
 TITLE GM FEIN 311239207 ADDRESS CHANGES TO BE NOTED ABOVE

WHEN RESPONDING TO SOLICITATION, INSERT NAME AND ADDRESS IN SPACE ABOVE LABELED 'VENDOR'

INSTRUCTIONS TO VENDORS SUBMITTING BIDS

1. **REVIEW DOCUMENTS THOROUGHLY:** The attached documents contain a solicitation for bids. Please read these instructions and all documents attached in their entirety. These instructions provide critical information about requirements that if overlooked could lead to disqualification of a Vendor's bid. All bids must be submitted in accordance with the provisions contained in these instructions and the Solicitation. Failure to do so may result in disqualification of Vendor's bid.
2. **MANDATORY TERMS:** The Solicitation may contain mandatory provisions identified by the use of the words "must," "will," and "shall." Failure to comply with a mandatory term in the Solicitation will result in bid disqualification.
3. **PREBID MEETING:** The item identified below shall apply to this Solicitation.

A pre-bid meeting will not be held prior to bid opening.

A **NON-MANDATORY PRE-BID** meeting will be held at the following place and time:

--

A **MANDATORY PRE-BID** meeting will be held at the following place and time:

--

All Vendors submitting a bid must attend the mandatory pre-bid meeting. Failure to attend the mandatory pre-bid meeting shall result in disqualification of the Vendor's bid. No one person attending the pre-bid meeting may represent more than one Vendor.

An attendance sheet provided at the pre-bid meeting shall serve as the official document verifying attendance. The State will not accept any other form of proof or documentation to verify attendance. Any person attending the pre-bid meeting on behalf of a Vendor must list on the attendance sheet his or her name and the name of the Vendor he or she is representing. Additionally, the person attending the pre-bid meeting should include the Vendor's E-Mail address, phone number, and Fax number on the attendance sheet. It is the Vendor's responsibility to locate the attendance sheet and provide the required

information. Failure to complete the attendance sheet as required may result in disqualification of Vendor's bid.

All Vendors should arrive prior to the starting time for the pre-bid. Vendors who arrive after the starting time but prior to the end of the pre-bid will be permitted to sign in, but are charged with knowing all matters discussed at the pre-bid.

Questions submitted at least five business days prior to a scheduled pre-bid will be discussed at the pre-bid meeting if possible. Any discussions or answers to questions at the pre-bid meeting are preliminary in nature and are non-binding. Official and binding answers to questions will be published in a written addendum to the Solicitation prior to bid opening.

- 4. **VENDOR QUESTION DEADLINE:** Vendors may submit questions relating to this Solicitation to the Purchasing Division. Questions must be submitted in writing. All questions must be submitted on or before the date listed below and to the address listed below in order to be considered. A written response will be published in a Solicitation addendum if a response is possible and appropriate. Non-written discussions, conversations, or questions and answers regarding this Solicitation are preliminary in nature and are non-binding.

Question Submission Deadline:

Submit Questions to:

 Fax:
 Email:

- 5. **VERBAL COMMUNICATION:** Any verbal communication between the Vendor and any State personnel is not binding, including that made at the mandatory pre-bid conference. Only information issued in writing and added to the Solicitation by an official written addendum by the Purchasing Division is binding.
- 6. **BID SUBMISSION:** All bids must be signed and delivered by the Vendor to the Purchasing Division at the address listed below on or before the date and time of the bid opening. Any bid received by the Purchasing Division staff is considered to be in the possession of the Purchasing Division and will not be returned for any reason. The bid delivery address is:

Department of Administration, Purchasing Division
 2019 Washington Street East
 P.O. Box 50130,
 Charleston, WV 25305-0130

The bid should contain the information listed below on the face of the envelope or the bid may not be considered:

SEALED BID

BUYER: _____
 SOLICITATION NO.: _____
 BID OPENING DATE: _____
 BID OPENING TIME: _____
 FAX NUMBER: _____

In the event that Vendor is responding to a request for proposal, the Vendor shall submit one original technical and one original cost proposal plus convenience copies of each to the Purchasing Division at the address shown above. Additionally, the Vendor should identify the bid type as either a technical or cost proposal on the face of each bid envelope submitted in response to a request for proposal as follows:

BID TYPE: Technical
 Cost

7. **BID OPENING:** Bids submitted in response to this Solicitation will be opened at the location identified below on the date and time listed below. Delivery of a bid after the bid opening date and time will result in bid disqualification. For purposes of this Solicitation, a bid is considered delivered when time stamped by the official Purchasing Division time clock.

Bid Opening Date and Time:

March 05, 2013 at 1:30 PM. EST

Bid Opening Location:

Department of Administration, Purchasing Division
 2019 Washington Street East
 P.O. Box 50130,
 Charleston, WV 25305-0130

8. **ADDENDUM ACKNOWLEDGEMENT:** Changes or revisions to this Solicitation will be made by an official written addendum issued by the Purchasing Division. Vendor should acknowledge receipt of all addenda issued with this Solicitation by completing an Addendum Acknowledgment Form, a copy of which is included herewith. Failure to acknowledge addenda may result in bid disqualification. The addendum acknowledgement should be submitted with the bid to expedite document processing.
9. **BID FORMATTING:** Vendor should type or electronically enter the information onto its bid to prevent errors in the evaluation. Failure to type or electronically enter the information may result in bid disqualification.

GENERAL TERMS AND CONDITIONS:

1. **CONTRACTUAL AGREEMENT:** Issuance of a Purchase Order signed by the Purchasing Division Director, or his designee, and approved as to form by the Attorney General's office constitutes acceptance of this Contract made by and between the State of West Virginia and the Vendor. Vendor's signature on its bid signifies Vendor's agreement to be bound by and accept the terms and conditions contained in this Contract.

2. **DEFINITIONS:** As used in this Solicitation / Contract, the following terms shall have the meanings attributed to them below. Additional definitions may be found in the specifications included with this Solicitation / Contract.
 - 2.1 **"Agency" or "Agencies"** means the agency, board, commission, or other entity of the State of West Virginia that is identified on the first page of the Solicitation or any other public entity seeking to procure goods or services under this Contract.
 - 2.2 **"Contract"** means the binding agreement that is entered into between the State and the Vendor to provide the goods and services requested in the Solicitation.
 - 2.3 **"Director"** means the Director of the West Virginia Department of Administration, Purchasing Division.
 - 2.4 **"Purchasing Division"** means the West Virginia Department of Administration, Purchasing Division.
 - 2.5 **"Purchase Order"** means the document signed by the Agency and the Purchasing Division, and approved as to form by the Attorney General, that identifies the Vendor as the successful bidder and Contract holder.
 - 2.6 **"Solicitation"** means the official solicitation published by the Purchasing Division and identified by number on the first page thereof.
 - 2.7 **"State"** means the State of West Virginia and/or any of its agencies, commissions, boards, etc. as context requires.
 - 2.8 **"Vendor" or "Vendors"** means any entity submitting a bid in response to the Solicitation, the entity that has been selected as the lowest responsible bidder, or the entity that has been awarded the Contract as context requires.

3. **CONTRACT TERM; RENEWAL; EXTENSION:** The term of this Contract shall be determined in accordance with the category that has been identified as applicable to this Contract below:

Term Contract

Initial Contract Term: This Contract becomes effective on

and extends for a period of year(s).

Renewal Term: This Contract may be renewed upon the mutual written consent of the Agency, and the Vendor, with approval of the Purchasing Division and the Attorney General's office (Attorney General approval is as to form only). Any request for renewal must be submitted to the Purchasing Division Director thirty (30) days prior to the expiration date of the initial contract term or appropriate renewal term. A Contract renewal shall be in accordance with the terms and conditions of the original contract. Renewal of this Contract is limited to successive one (1) year periods. Automatic renewal of this Contract is prohibited. Notwithstanding the foregoing, Purchasing Division approval is not required on agency delegated or exempt purchases. Attorney General approval may be required for vendor terms and conditions.

Reasonable Time Extension: At the sole discretion of the Purchasing Division Director, and with approval from the Attorney General's office (Attorney General approval is as to form only), this Contract may be extended for a reasonable time after the initial Contract term or after any renewal term as may be necessary to obtain a new contract or renew this Contract. Any reasonable time extension shall not exceed twelve (12) months. Vendor may avoid a reasonable time extension by providing the Purchasing Division Director with written notice of Vendor's desire to terminate this Contract 30 days prior to the expiration of the then current term. During any reasonable time extension period, the Vendor may terminate this Contract for any reason upon giving the Purchasing Division Director 30 days written notice. Automatic extension of this Contract is prohibited. Notwithstanding the foregoing, Purchasing Division approval is not required on agency delegated or exempt purchases, but Attorney General approval may be required.

Fixed Period Contract: This Contract becomes effective upon Vendor's receipt of the notice to proceed and must be completed within days.

One Time Purchase: The term of this Contract shall run for one year from the date the Purchase Order is issued or from the date the Purchase Order is issued until all of the goods contracted for have been delivered, whichever is shorter.

Other: See attached.

4. **NOTICE TO PROCEED:** Vendor shall begin performance of this Contract immediately upon receiving notice to proceed unless otherwise instructed by the Agency. Unless otherwise specified, the fully executed Purchase Order will be considered notice to proceed
5. **QUANTITIES:** The quantities required under this Contract shall be determined in accordance with the category that has been identified as applicable to this Contract below.
- Open End Contract:** Quantities listed in this Solicitation are approximations only, based on estimates supplied by the Agency. It is understood and agreed that the Contract shall cover the quantities actually ordered for delivery during the term of the Contract, whether more or less than the quantities shown.
 - Service:** The scope of the service to be provided will be more clearly defined in the specifications included herewith.
 - Combined Service and Goods:** The scope of the service and deliverable goods to be provided will be more clearly defined in the specifications included herewith.
 - One Time Purchase:** This Contract is for the purchase of a set quantity of goods that are identified in the specifications included herewith. Once those items have been delivered, no additional goods may be procured under this Contract without an appropriate change order approved by the Vendor, Agency, Purchasing Division, and Attorney General's office.
6. **PRICING:** The pricing set forth herein is firm for the life of the Contract, unless specified elsewhere within this Solicitation/Contract by the State. A Vendor's inclusion of price adjustment provisions in its bid, without an express authorization from the State in the Solicitation to do so, may result in bid disqualification.
7. **EMERGENCY PURCHASES:** The Purchasing Division Director may authorize the Agency to purchase goods or services in the open market that Vendor would otherwise provide under this Contract if those goods or services are for immediate or expedited delivery in an emergency. Emergencies shall include, but are not limited to, delays in transportation or an unanticipated increase in the volume of work. An emergency purchase in the open market, approved by the Purchasing Division Director, shall not constitute a breach of this Contract and shall not entitle the Vendor to any form of compensation or damages. This provision does not excuse the State from fulfilling its obligations under a One Time Purchase contract.
8. **REQUIRED DOCUMENTS:** All of the items checked below must be provided to the Purchasing Division by the Vendor as specified below.
- BID BOND:** All Vendors shall furnish a bid bond in the amount of five percent (5%) of the total amount of the bid protecting the State of West Virginia. The bid bond must be submitted with the bid.

| | **PERFORMANCE BOND:** The apparent successful Vendor shall provide a performance bond in the amount of [redacted]. The performance bond must be issued and received by the Purchasing Division prior to Contract award. On construction contracts, the performance bond must be 100% of the Contract value.

| | **LABOR/MATERIAL PAYMENT BOND:** The apparent successful Vendor shall provide a labor/material payment bond in the amount of 100% of the Contract value. The labor/material payment bond must be issued and delivered to the Purchasing Division prior to Contract award.

In lieu of the Bid Bond, Performance Bond, and Labor/Material Payment Bond, the Vendor may provide certified checks, cashier's checks, or irrevocable letters of credit. Any certified check, cashier's check, or irrevocable letter of credit provided in lieu of a bond must be of the same amount and delivered on the same schedule as the bond it replaces. A letter of credit submitted in lieu of a performance and labor/material payment bond will only be allowed for projects under \$100,000. Personal or business checks are not acceptable.

| | **MAINTENANCE BOND:** The apparent successful Vendor shall provide a two (2) year maintenance bond covering the roofing system. The maintenance bond must be issued and delivered to the Purchasing Division prior to Contract award.

| | **WORKERS' COMPENSATION INSURANCE:** The apparent successful Vendor shall have appropriate workers' compensation insurance and shall provide proof thereof upon request.

| | **INSURANCE:** The apparent successful Vendor shall furnish proof of the following insurance prior to Contract award:

[| **Commercial General Liability Insurance:**
[redacted] \$1,000,000.00 or more.

[| **Builders Risk Insurance:** builders risk – all risk insurance in an amount equal to 100% of the amount of the Contract.

[| [redacted]

[| [redacted]

[| [redacted]

[| [redacted]

[| [redacted]

The apparent successful Vendor shall also furnish proof of any additional insurance requirements contained in the specifications prior to Contract award regardless of whether or not that insurance requirement is listed above.

LICENSE(S) / CERTIFICATIONS / PERMITS: In addition to anything required under the Section entitled Licensing, of the General Terms and Conditions, the apparent successful Vendor shall furnish proof of the following licenses, certifications, and/or permits prior to Contract award, in a form acceptable to the Purchasing Division.

[]	
[]	
[]	
[]	

The apparent successful Vendor shall also furnish proof of any additional licenses or certifications contained in the specifications prior to Contract award regardless of whether or not that requirement is listed above.

9. LITIGATION BOND: The Director reserves the right to require any Vendor that files a protest of an award to submit a litigation bond in the amount equal to one percent of the lowest bid submitted or \$5,000, whichever is greater. The entire amount of the bond shall be forfeited if the hearing officer determines that the protest was filed for frivolous or improper purpose, including but not limited to, the purpose of harassing, causing unnecessary delay, or needless expense for the Agency. All litigation bonds shall be made payable to the Purchasing Division. In lieu of a bond, the protester may submit a cashier's check or certified check payable to the Purchasing Division. Cashier's or certified checks will be deposited with and held by the State Treasurer's office. If it is determined that the protest has not been filed for frivolous or improper purpose, the bond or deposit shall be returned in its entirety.

10. ALTERNATES: Any model, brand, or specification listed herein establishes the acceptable level of quality only and is not intended to reflect a preference for, or in any way favor, a particular brand or vendor. Vendors may bid alternates to a listed model or brand provided that the alternate is at least equal to the model or brand and complies with the required specifications. The equality of any alternate being bid shall be determined by the State at its sole discretion. Any Vendor bidding an alternate model or brand should clearly identify the alternate items in its bid and should include manufacturer's specifications, industry literature, and/or any other relevant documentation demonstrating the equality of the alternate items. Failure to provide information for alternate items may be grounds for rejection of a Vendor's bid.

11. EXCEPTIONS AND CLARIFICATIONS: The Solicitation contains the specifications that shall form the basis of a contractual agreement. Vendor shall clearly mark any exceptions, clarifications, or

other proposed modifications in its bid. Exceptions to, clarifications of, or modifications of a requirement or term and condition of the Solicitation may result in bid disqualification.

12. LIQUIDATED DAMAGES: Vendor shall pay liquidated damages in the amount

for .

This clause shall in no way be considered exclusive and shall not limit the State or Agency's right to pursue any other available remedy.

13. ACCEPTANCE/REJECTION: The State may accept or reject any bid in whole, or in part. Vendor's signature on its bid signifies acceptance of the terms and conditions contained in the Solicitation and Vendor agrees to be bound by the terms of the Contract, as reflected in the Purchase Order, upon receipt.

14. REGISTRATION: Prior to Contract award, the apparent successful Vendor must be properly registered with the West Virginia Purchasing Division and must have paid the \$125 fee if applicable.

15. COMMUNICATION LIMITATIONS: In accordance with West Virginia Code of State Rules §148-1-6.6, communication with the State of West Virginia or any of its employees regarding this Solicitation during the solicitation, bid, evaluation or award periods, except through the Purchasing Division, is strictly prohibited without prior Purchasing Division approval. Purchasing Division approval for such communication is implied for all agency delegated and exempt purchases.

16. FUNDING: This Contract shall continue for the term stated herein, contingent upon funds being appropriated by the Legislature or otherwise being made available. In the event funds are not appropriated or otherwise made available, this Contract becomes void and of no effect beginning on July 1 of the fiscal year for which funding has not been appropriated or otherwise made available.

17. PAYMENT: Payment in advance is prohibited under this Contract. Payment may only be made after the delivery and acceptance of goods or services. The Vendor shall submit invoices, in arrears, to the Agency at the address on the face of the purchase order labeled "Invoice To."

18. UNIT PRICE: Unit prices shall prevail in cases of a discrepancy in the Vendor's bid.

19. DELIVERY: All quotations are considered freight on board destination ("F.O.B. destination") unless alternate shipping terms are clearly identified in the bid. Vendor's listing of shipping terms that contradict the shipping terms expressly required by this Solicitation may result in bid disqualification.

20. INTEREST: Interest attributable to late payment will only be permitted if authorized by the West Virginia Code. Presently, there is no provision in the law for interest on late payments.

21. PREFERENCE: Vendor Preference may only be granted upon written request and only in accordance with the West Virginia Code § 5A-3-37 and the West Virginia Code of State Rules. A Resident Vendor Certification form has been attached hereto to allow Vendor to apply for the preference. Vendor's

failure to submit the Resident Vendor Certification form with its bid will result in denial of Vendor Preference. Vendor Preference does not apply to construction projects.

- 22. SMALL, WOMEN-OWNED, OR MINORITY-OWNED BUSINESSES:** For any solicitations publicly advertised for bid on or after July 1, 2012, in accordance with West Virginia Code §5A-3-37(a)(7) and W. Va. CSR § 148-22-9, any non-resident vendor certified as a small, women-owned, or minority-owned business under W. Va. CSR § 148-22-9 shall be provided the same preference made available to any resident vendor. Any non-resident small, women-owned, or minority-owned business must identify itself as such in writing, must submit that writing to the Purchasing Division with its bid, and must be properly certified under W. Va. CSR § 148-22-9 prior to submission of its bid to receive the preferences made available to resident vendors. Preference for a non-resident small, women-owned, or minority owned business shall be applied in accordance with W. Va. CSR § 148-22-9.
- 23. TAXES:** The Vendor shall pay any applicable sales, use, personal property or any other taxes arising out of this Contract and the transactions contemplated thereby. The State of West Virginia is exempt from federal and state taxes and will not pay or reimburse such taxes.
- 24. CANCELLATION:** The Purchasing Division Director reserves the right to cancel this Contract immediately upon written notice to the vendor if the materials or workmanship supplied do not conform to the specifications contained in the Contract. The Purchasing Division Director may cancel any purchase or Contract upon 30 days written notice to the Vendor in accordance with West Virginia Code of State Rules § 148-1-7.16.2.
- 25. WAIVER OF MINOR IRREGULARITIES:** The Director reserves the right to waive minor irregularities in bids or specifications in accordance with West Virginia Code of State Rules § 148-1-4.6.
- 26. TIME:** Time is of the essence with regard to all matters of time and performance in this Contract.
- 27. APPLICABLE LAW:** This Contract is governed by and interpreted under West Virginia law without giving effect to its choice of law principles. Any information provided in specification manuals, or any other source, verbal or written, which contradicts or violates the West Virginia Constitution, West Virginia Code or West Virginia Code of State Rules is void and of no effect.
- 28. COMPLIANCE:** Vendor shall comply with all applicable federal, state, and local laws, regulations and ordinances. By submitting a bid, Vendors acknowledge that they have reviewed, understand, and will comply with all applicable law.
- 29. PREVAILING WAGE:** On any contract for the construction of a public improvement, Vendor and any subcontractors utilized by Vendor shall pay a rate or rates of wages which shall not be less than the fair minimum rate or rates of wages (prevailing wage), as established by the West Virginia Division of Labor under West Virginia Code §§ 21-5A-1 et seq. and available at <http://www.sos.wv.gov/administrative-law/wagerates/Pages/default.aspx>. Vendor shall be responsible for ensuring compliance with prevailing wage requirements and determining when prevailing wage

requirements are applicable. The required contract provisions contained in West Virginia Code of State Rules § 42-7-3 are specifically incorporated herein by reference.

- 30. ARBITRATION:** Any references made to arbitration contained in this Contract, Vendor's bid, or in any American Institute of Architects documents pertaining to this Contract are hereby deleted, void, and of no effect.
- 31. MODIFICATIONS:** This writing is the parties' final expression of intent. Notwithstanding anything contained in this Contract to the contrary, no modification of this Contract shall be binding without mutual written consent of the Agency, and the Vendor, with approval of the Purchasing Division and the Attorney General's office (Attorney General approval is as to form only). **No Change shall be implemented by the Vendor until such time as the Vendor receives an approved written change order from the Purchasing Division.**
- 32. WAIVER:** The failure of either party to insist upon a strict performance of any of the terms or provision of this Contract, or to exercise any option, right, or remedy herein contained, shall not be construed as a waiver or a relinquishment for the future of such term, provision, option, right, or remedy, but the same shall continue in full force and effect. Any waiver must be expressly stated in writing and signed by the waiving party.
- 33. SUBSEQUENT FORMS:** The terms and conditions contained in this Contract shall supersede any and all subsequent terms and conditions which may appear on any form documents submitted by Vendor to the Agency or Purchasing Division such as price lists, order forms, invoices, sales agreements, or maintenance agreements, and includes internet websites or other electronic documents. Acceptance or use of Vendor's forms does not constitute acceptance of the terms and conditions contained thereon.
- 34. ASSIGNMENT:** Neither this Contract nor any monies due, or to become due hereunder, may be assigned by the Vendor without the express written consent of the Agency, the Purchasing Division, the Attorney General's office (as to form only), and any other government agency or office that may be required to approve such assignments. Notwithstanding the foregoing, Purchasing Division approval may or may not be required on certain agency delegated or exempt purchases.
- 35. WARRANTY:** The Vendor expressly warrants that the goods and/or services covered by this Contract will: (a) conform to the specifications, drawings, samples, or other description furnished or specified by the Agency; (b) be merchantable and fit for the purpose intended; and (c) be free from defect in material and workmanship.
- 36. STATE EMPLOYEES:** State employees are not permitted to utilize this Contract for personal use and the Vendor is prohibited from permitting or facilitating the same.
- 37. BANKRUPTCY:** In the event the Vendor files for bankruptcy protection, the State of West Virginia may deem this Contract null and void, and terminate this Contract without notice.

- 38. HIPAA BUSINESS ASSOCIATE ADDENDUM:** The West Virginia State Government HIPAA Business Associate Addendum (BAA), approved by the Attorney General, is available online at <http://www.state.wv.us/admin/purchase/vrc/hipaa.html> and is hereby made part of the agreement provided that the Agency meets the definition of a Covered entity (45 CFR §160.103) and will be disclosing Protected Health Information (45 CFR §160.103) to the Vendor.
- 39. CONFIDENTIALITY:** The Vendor agrees that it will not disclose to anyone, directly or indirectly, any such personally identifiable information or other confidential information gained from the Agency, unless the individual who is the subject of the information consents to the disclosure in writing or the disclosure is made pursuant to the Agency's policies, procedures, and rules. Vendor further agrees to comply with the Confidentiality Policies and Information Security Accountability Requirements, set forth in <http://www.state.wv.us/admin/purchase/privacy/default.html>.
- 40. DISCLOSURE:** Vendor's response to the Solicitation and the resulting Contract are considered public documents and will be disclosed to the public in accordance with the laws, rules, and policies governing the West Virginia Purchasing Division. Those laws include, but are not limited to, the Freedom of Information Act found in West Virginia Code § 29B-1-1 et seq.

If a Vendor considers any part of its bid to be exempt from public disclosure, Vendor must so indicate by specifically identifying the exempt information, identifying the exemption that applies, providing a detailed justification for the exemption, segregating the exempt information from the general bid information, and submitting the exempt information as part of its bid but in a segregated and clearly identifiable format. Failure to comply with the foregoing requirements will result in public disclosure of the Vendor's bid without further notice. A Vendor's act of marking all or nearly all of its bid as exempt is not sufficient to avoid disclosure and WILL NOT BE HONORED. Vendor's act of marking a bid or any part thereof as "confidential" or "proprietary" is not sufficient to avoid disclosure and WILL NOT BE HONORED. In addition, a legend or other statement indicating that all or substantially all of the bid is exempt from disclosure is not sufficient to avoid disclosure and WILL NOT BE HONORED. Vendor will be required to defend any claimed exemption for nondisclosure in the event of an administrative or judicial challenge to the State's nondisclosure. Vendor must indemnify the State for any costs incurred related to any exemptions claimed by Vendor. Any questions regarding the applicability of the various public records laws should be addressed to your own legal counsel prior to bid submission.

- 41. LICENSING:** In accordance with West Virginia Code of State Rules §148-1-6.1.7, Vendor must be licensed and in good standing in accordance with any and all state and local laws and requirements by any state or local agency of West Virginia, including, but not limited to, the West Virginia Secretary of State's Office, the West Virginia Tax Department, West Virginia Insurance Commission, or any other state agency or political subdivision. Upon request, the Vendor must provide all necessary releases to obtain information to enable the Purchasing Division Director or the Agency to verify that the Vendor is licensed and in good standing with the above entities.

- 42. ANTITRUST:** In submitting a bid to, signing a contract with, or accepting a Purchase Order from any agency of the State of West Virginia, the Vendor agrees to convey, sell, assign, or transfer to the State of West Virginia all rights, title, and interest in and to all causes of action it may now or hereafter acquire under the antitrust laws of the United States and the State of West Virginia for price fixing and/or unreasonable restraints of trade relating to the particular commodities or services purchased or acquired by the State of West Virginia. Such assignment shall be made and become effective at the time the purchasing agency tenders the initial payment to Vendor.
- 43. VENDOR CERTIFICATIONS:** By signing its bid or entering into this Contract, Vendor certifies (1) that its bid was made without prior understanding, agreement, or connection with any corporation, firm, limited liability company, partnership, person or entity submitting a bid for the same material, supplies, equipment or services; (2) that its bid is in all respects fair and without collusion or fraud; (3) that this Contract is accepted or entered into without any prior understanding, agreement, or connection to any other entity that could be considered a violation of law; and (4) that it has reviewed this RFQ in its entirety; understands the requirements, terms and conditions, and other information contained herein. Vendor's signature on its bid also affirms that neither it nor its representatives have any interest, nor shall acquire any interest, direct or indirect, which would compromise the performance of its services hereunder. Any such interests shall be promptly presented in detail to the Agency.

The individual signing this bid on behalf of Vendor certifies that he or she is authorized by the Vendor to execute this bid or any documents related thereto on Vendor's behalf; that he or she is authorized to bind the Vendor in a contractual relationship; and that, to the best of his or her knowledge, the Vendor has properly registered with any State agency that may require registration.

- 44. PURCHASING CARD ACCEPTANCE:** The State of West Virginia currently utilizes a Purchasing Card program, administered under contract by a banking institution, to process payment for goods and services. The Vendor must accept the State of West Virginia's Purchasing Card for payment of all orders under this Contract unless the box below is checked.

Vendor is not required to accept the State of West Virginia's Purchasing Card as payment for all goods and services.

- 45. VENDOR RELATIONSHIP:** The relationship of the Vendor to the State shall be that of an independent contractor and no principal-agent relationship or employer-employee relationship is contemplated or created by this Contract. The Vendor as an independent contractor is solely liable for the acts and omissions of its employees and agents. Vendor shall be responsible for selecting, supervising, and compensating any and all individuals employed pursuant to the terms of this Solicitation and resulting contract. Neither the Vendor, nor any employees or subcontractors of the Vendor, shall be deemed to be employees of the State for any purpose whatsoever. Vendor shall be exclusively responsible for payment of employees and contractors for all wages and salaries, taxes, withholding payments, penalties, fees, fringe benefits, professional liability insurance premiums, contributions to insurance and pension, or other deferred compensation plans, including but not limited to, Workers' Compensation and Social Security obligations, licensing fees, *etc.* and the filing of all necessary documents, forms and returns pertinent to all of the foregoing. Vendor shall hold harmless the

State, and shall provide the State and Agency with a defense against any and all claims including, but not limited to, the foregoing payments, withholdings, contributions, taxes, Social Security taxes, and employer income tax returns.

- 46. INDEMNIFICATION:** The Vendor agrees to indemnify, defend, and hold harmless the State and the Agency, their officers, and employees from and against: (1) Any claims or losses for services rendered by any subcontractor, person, or firm performing or supplying services, materials, or supplies in connection with the performance of the Contract; (2) Any claims or losses resulting to any person or entity injured or damaged by the Vendor, its officers, employees, or subcontractors by the publication, translation, reproduction, delivery, performance, use, or disposition of any data used under the Contract in a manner not authorized by the Contract, or by Federal or State statutes or regulations; and (3) Any failure of the Vendor, its officers, employees, or subcontractors to observe State and Federal laws including, but not limited to, labor and wage and hour laws.
- 47. PURCHASING AFFIDAVIT:** In accordance with West Virginia Code § 5A-3-10a, all Vendors are required to sign, notarize, and submit the Purchasing Affidavit stating that neither the Vendor nor a related party owe a debt to the State in excess of \$1,000. The affidavit must be submitted prior to award, but should be submitted with the Vendor's bid. A copy of the Purchasing Affidavit is included herewith.
- 48. ADDITIONAL AGENCY AND LOCAL GOVERNMENT USE:** This Contract may be utilized by and extends to other agencies, spending units, and political subdivisions of the State of West Virginia; county, municipal, and other local government bodies; and school districts ("Other Government Entities"). This Contract shall be extended to the aforementioned Other Government Entities on the same prices, terms, and conditions as those offered and agreed to in this Contract. If the Vendor does not wish to extend the prices, terms, and conditions of its bid and subsequent contract to the Other Government Entities, the Vendor must clearly indicate such refusal in its bid. A refusal to extend this Contract to the Other Government Entities shall not impact or influence the award of this Contract in any manner.
- 49. CONFLICT OF INTEREST:** Vendor, its officers or members or employees, shall not presently have or acquire any interest, direct or indirect, which would conflict with or compromise the performance of its obligations hereunder. Vendor shall periodically inquire of its officers, members and employees to ensure that a conflict of interest does not arise. Any conflict of interest discovered shall be promptly presented in detail to the Agency.
- 50. REPORTS:** Vendor shall provide the Agency and/or the Purchasing Division with the following reports identified by a checked box below:
- Such reports as the Agency and/or the Purchasing Division may request. Requested reports may include, but are not limited to, quantities purchased, agencies utilizing the contract, total contract expenditures by agency, etc.

- [| Quarterly reports detailing the total quantity of purchases in units and dollars, along with a listing of purchases by agency. Quarterly reports should be delivered to the Purchasing Division via email at purchasing.requisitions@wv.gov.

51. BACKGROUND CHECK: In accordance with W. Va. Code § 15-2D-3, the Director of the Division of Protective Services shall require any service provider whose employees are regularly employed on the grounds or in the buildings of the Capitol complex or who have access to sensitive or critical information to submit to a fingerprint-based state and federal background inquiry through the state repository.

After the contract for such services has been approved, but before any such employees are permitted to be on the grounds or in the buildings of the Capitol complex or have access to sensitive or critical information, the service provider shall submit a list of all persons who will be physically present and working at the Capitol complex to the Director of the Division of Protective Services for purposes of verifying compliance with this provision.

The State reserves the right to prohibit a service provider's employees from accessing sensitive or critical information or to be present at the Capitol complex based upon results addressed from a criminal background check.

52. PREFERENCE FOR USE OF DOMESTIC STEEL PRODUCTS: Except when authorized by the Director of the Purchasing Division pursuant to W. Va. Code § 5A-3-56, no contractor may use or supply steel products for a State Contract Project other than those steel products made in the United States. A contractor who uses steel products in violation of this section may be subject to civil penalties pursuant to W. Va. Code § 5A-3-56. As used in this section:

- a. "State Contract Project" means any erection or construction of, or any addition to, alteration of or other improvement to any building or structure, including, but not limited to, roads or highways, or the installation of any heating or cooling or ventilating plants or other equipment, or the supply of and materials for such projects, pursuant to a contract with the State of West Virginia for which bids were solicited on or after June 6, 2001.
- b. "Steel Products" means products rolled, formed, shaped, drawn, extruded, forged, cast, fabricated or otherwise similarly processed, or processed by a combination of two or more or such operations, from steel made by the open heath, basic oxygen, electric furnace, Bessemer or other steel making process.

The Purchasing Division Director may, in writing, authorize the use of foreign steel products if:

- a. The cost for each contract item used does not exceed one tenth of one percent (.1%) of the total contract cost or two thousand five hundred dollars (\$2,500.00), whichever is greater. For the purposes of this section, the cost is the value of the steel product as delivered to the project; or

- b. The Director of the Purchasing Division determines that specified steel materials are not produced in the United States in sufficient quantity or otherwise are not reasonably available to meet contract requirements.

53. PREFERENCE FOR USE OF DOMESTIC ALUMINUM, GLASS, AND STEEL: In Accordance with W. Va. Code § 5-19-1 et seq., and W. Va. CSR § 148-10-1 et seq., for every contract or subcontract, subject to the limitations contained herein, for the construction, reconstruction, alteration, repair, improvement or maintenance of public works or for the purchase of any item of machinery or equipment to be used at sites of public works, only domestic aluminum, glass or steel products shall be supplied unless the spending officer determines, in writing, after the receipt of offers or bids, (1) that the cost of domestic aluminum, glass or steel products is unreasonable or inconsistent with the public interest of the State of West Virginia, (2) that domestic aluminum, glass or steel products are not produced in sufficient quantities to meet the contract requirements, or (3) the available domestic aluminum, glass, or steel do not meet the contract specifications. This provision only applies to public works contracts awarded in an amount more than fifty thousand dollars (\$50,000) or public works contracts that require more than ten thousand pounds of steel products.

The cost of domestic aluminum, glass, or steel products may be unreasonable if the cost is more than twenty percent (20%) of the bid or offered price for foreign made aluminum, glass, or steel products. If the domestic aluminum, glass or steel products to be supplied or produced in a "substantial labor surplus area", as defined by the United States Department of Labor, the cost of domestic aluminum, glass, or steel products may be unreasonable if the cost is more than thirty percent (30%) of the bid or offered price for foreign made aluminum, glass, or steel products.

This preference shall be applied to an item of machinery or equipment, as indicated above, when the item is a single unit of equipment or machinery manufactured primarily of aluminum, glass or steel, is part of a public works contract and has the sole purpose or of being a permanent part of a single public works project. This provision does not apply to equipment or machinery purchased by a spending unit for use by that spending unit and not as part of a single public works project.

All bids and offers including domestic aluminum, glass or steel products that exceed bid or offer prices including foreign aluminum, glass or steel products after application of the preferences provided in this provision may be reduced to a price equal to or lower than the lowest bid or offer price for foreign aluminum, glass or steel products plus the applicable preference. If the reduced bid or offer prices are made in writing and supersede the prior bid or offer prices, all bids or offers, including the reduced bid or offer prices, will be reevaluated in accordance with this rule.

REQUEST FOR QUOTATION
RFQ PSC1010

SPECIFICATIONS

1. **PURPOSE AND SCOPE:** The West Virginia Purchasing Division is soliciting bids on behalf of Public Service Commission of WV to establish an open-end contract to provide uniforms and work related equipment for field inspection staff that require like clothing for identification and safety purposes. The transportation enforcement division as well as gas pipeline section.
2. **DEFINITIONS:** The terms listed below shall have the meanings assigned to them below. Additional definitions can be found in section 2 of the General Terms and Conditions.
 - 2.1 **“Contract Item” or “Contract Items”** means the list of items identified in Section III, Subsection 1 below.
 - 2.2 **“Pricing Pages”** means the schedule of prices, estimated order quantity, and totals attached hereto as Exhibit A and used to evaluate the RFQ.
 - 2.3 **“RFQ”** means the official request for quotation published by the Purchasing Division and identified as RFQ NO. PSC1010
3. **GENERAL REQUIREMENTS:**
 - 3.1 **Contract Items and Mandatory Requirements:** Vendor shall provide Agency with the Contract Items listed below on an open-end and continuing basis. Contract Items must meet or exceed the mandatory requirements as shown below.

3.1.1

Dress Pants - Fechheimer Brothers Company - Style #32282 or equivalent to

Color: Oxford Grey

Fabric: 55% polyester / 45% wool

Weight: 8 - 8.5 oz. per linear yard

Weave: Tropical

3.1.1.1 Style: Trouser shall be manufactured from an up to date men's uniform trouser pattern. The trouser styling shall be T-1: plain front, two (2) quarter top front pockets, and two (2) hip pockets professionally finished with no visible topstitching. Work wear industrial style construction is unacceptable and shall be cause for rejection.

3.1.1.2 Lining Material: The pocketing and fly lining material shall be 70% polyester / 30% cotton, 2.9 oz per square yard (60" width) with a minimum 78 x 48 count. Pocketing must have a durable press finish and the color of the pocketing must be black.

3.1.1.3 Waistband: The waistband shall be constructed using the "closed method" and shall measure a minimum of 1-7/8" wide when finished. (For women: the trouser will be made with the Freedom Fit waistband system, which is designed to provide the wearer with a more comfortable and better fitting trouser). The waistband curtain shall finish a minimum 2-1/8" wide and is to be made of the same fabric and color as the pocketing material and must be attached to the top of the trouser with a zigzag stitch. The waistband must contain 3/4 inch Ban Roll to prevent roll over at the trouser front and strand snugtex to keep shirts tucked in. The waistband closure shall be accomplished with a single crush proof hook and eye centered on the waistband for wearer comfort. The hook and eye shall be reinforced with 7/8 inch non woven stay tape that is anchored with topstitching through and through to the top of the waistband (bar tacks in place of topstitching shall be cause for rejection). In addition to the stitching of the waistband when it is set onto the trouser, the waistband must also be topstitched below the waistband seam through the waistband curtain for added strength. The back center seam of the trouser to be finished to allow for alterations (with ample basic trouser fabric and waistband curtain material to allow trouser size to be increased at least one size). The outlet in the seat is to be in proportion to waist outlet so seat may also be let out. Seat seam must be sewn with a tandem needle machine (double needle stitch) for maximum strength.

3.1.1.4 For women: The waistband curtain is composed of two elastic components, which give it two-zone comfort fit and breathe ability.

The top part of the waistband curtain is interlined with a 1-1/2" elastic band that has two functions. It stabilizes the waistband, preventing waistband rollover, and allows for a comfort stretch when the wearer bends or sits. This elastic is around the entire waistband and is constructed with an open weave to allow for breath ability. The specification for the upper elastic is as follows:

	Width 1 1/2"
Overall content:	38% Polyester, 45% Nylon, 17% Spandex
Stretch:	20%

The upper part of the waistband curtain interlining (elastic band) is to be lined in black (the same color as the pocketing material) and it shall be cut on a 45-degree bias to allow for maximum stretch. The waistband basic trouser fabric shall be cut across the cloth to allow for maximum stretch in synergy with the Freedom Fit Waistband. The lower part of the waistband shall also be black and is designed to stretch over the hips for comfort and helps keep the trouser positioned properly on the waist. This elastic is also woven with an open weave for maximum breath ability. The lower elastic portion of the band has an area of exposed black Neoprene rubber, which acts as a shirt keeper. The specifications for the lower elastic are as follows:

Width: 1 3/4"

Overall Content: 13% Polyester, 49% Nylon, 16% Spandex, 22% Rubber

Stretch: 55%

The waistband curtain must contain Tru-Grip, a 1/2" surface area composed of thin 55 gauge rubber for maximum comfort and performance. The Tru-Grip acts to help keep shirts tucked in securely. (Substitution of a silicone strip or strips in place of Tru-Grip shall not be acceptable and shall be cause for rejection.)

3.1.1.5Belt Loops: There shall be a minimum of seven belt loops 3/4" in width of double thickness. Each loop must have a non-woven interlining for added durability. All loops (except back center) must be sewn into the top and bottom of the waistband ("dropped" belt loops that are tacked to the outside of the trouser all around waist shall be cause for rejection). The top of the belt loops (except back center) shall be sewn into the waistband curtain seam with a Rocap machine using a zigzag stitch. The bottom of the center back loop shall be tacked to the trouser and the top of the loop tacked to the outside of the waistband to allow for easier waist alternation.

3.1.1.6Fly: Trouser shall have a brass metal zipper with memory lock brass slider secured by metal stopper at base. There shall be a French Fly tab closure on the inside of the right fly. The tab shall be double ply made of the basic trouser fabric (tabs made of pocketing material or a "grown on" French Fly will be cause for rejection). The right fly shall be lined with the same material and color as the pocketing. The fly lining shall be sewn to the left fly continuing below the zipper into the crotch area in a neat and durable manner. A button shall be located on the left fly corresponding with the French Fly tab to provide a clean and comfortable closure. Topstitching of fly to be installed with automatic "J" stitch equipment eliminating puckering and providing a clean finish. There shall be a firm straight bar tack at the bottom of the fly going through the zipper tape for maximum strength. Bar tack shall line up with starting point of "J" stitch.

3.1.1.7Seat: Seat must be sewn with a Tandem Needle Machine (double-needle stitch) for maximum durability.

3.1.1.8Pockets: The two (2) front pockets will be quarter top style with a minimum opening of 6" and a minimum depth of 5-3/4" measured from the bottom of the opening. Front pockets to have firm straight bar tacks at top and bottom of pocket openings. Pockets shall be constructed using the stitch, turn, and topstitch method. Front pocket facing and barrier to be made of the

basic trouser fabric. Facing shall be a minimum of 1" and barrier shall measure a minimum of 2" (measured to the inside edge of pocket lining).

The two (2) hip pockets shall have a minimum 5-3/8" wide (bar tack to bar tack) opening and a minimum depth of 5-3/4" measured from the bottom of the pocket opening. Hip pockets shall be constructed using the double welt method on an automatic welt machine. The welts shall be finished in such a manner that there is no topstitching (topstitched hip pockets shall be cause for rejection). The corners of the hip pocket openings shall have straight bar tacks for reinforcement (use of triangular bar tacks shall be cause for rejection). Hip pocket facing and barrier are to be made of basic trouser fabric. Facing shall be a minimum of 3/4" and the barrier shall be a minimum of 1-1/2". The left hip pocket shall have a centered tab made of basic cloth inserted into the top welt with bar tacks at the top and bottom of the tab to form an opening for a button. A button shall be located below the bottom welt corresponding in location with the tab, which shall be interlined with non-woven for added durability. There shall be a dart centered above each hip pocket to waistband. Dart shall be approximately 2-3/4" long tapered from 3/8" at waistband and shall be installed with automatic equipment for a clean non-puckered finish.

3.1.1.9 Stitching, Pressing & Finishing: Trouser must be stitched with matching thread. Trouser must be neatly pressed on Hothead Presses and properly shaped. Out seams and inseams are edge serged on automatic equipment for uniformity of quality and shall be pressed open for a smooth pucker-free finish with repeated cleaning and pressing. Trouser must be cleaned and finished to eliminate loose threads.

3.1.1.10 Creases for Women: The leg creases, front and back will have a silicone bead put in by using the Lintrak process.

3.1.1.11 Stock Sizes:

Trouser must be available from stock in the following sizes:

SHORT RISE:	28 - 40 (EVEN ONLY)
REGULAR RISE:	28 - 56 (EVEN ONLY OVER 38)
LONG RISE:	32 - 42 (EVEN ONLY)

Trouser must have a permanent label providing care instructions and small woven label indicating waist size. A removable paper ticket showing the size, fabric content, cut number, and WPL or RN number must be on the outside of the waistband. Ticket to be matchbook style installed with plastic staples for easy removal without damaging trouser material and showing size when trousers are stacked.

3.1.1.12 For women: Trouser must be available from stock in the following sizes:

Women's 4 - 26

3.1.1.13 Labels: Trouser must have a permanent label providing care instructions and small woven label indicating waist size. A removable paper ticket showing the size, fabric content, cut number, and WPL or RN number must be on the outside of the waistband. Ticket to be matchbook style installed with plastic staples for easy removal without damaging trouser material and showing size when trousers are stacked.

3.1.2

Long Sleeve Shirts - Flying Cross Item #46W6691 or equivalent to

Color: Slate Grey

Content: 65% Dacron Polyester / 35% Rayon

Weight: 10.0 to 10.50 oz / linear yard

3.1.2.1 Style: Dress style, top center placket front, full cut tapered fit, banded collar, long sleeves with barrel cuffs, and dress shirttail. Two plain breast pockets with topstitched scalloped flaps. Topstitched shoulder straps. Full badge reinforcement. Matching inside yoke and collar band of Dacron/Cotton Poplin. Work wear industrial style shirt construction is unacceptable and shall be cause for rejection.

3.1.2.2 Collar and Stand: Collar points to measure 3-1/8" long with ultrasonically fused-in Mylar stays. Collar to have woven interlining of #285 Stabilized Mello-Press. Stays to be 3" long, 3/8" minimum width, and to be fused to underside of collar interlining. Stays applied directly to collar material itself unacceptable. Collar height at rear 1-1/2". Collar topstitched 1/4" off the edge. Collar stand to measure 1-5/16" at rear and band to be interlined with "Crease-N-Tack." Collar material itself (top or underside) shall have no fusing to Mylar stays or collar interlining.

3.1.2.3 Front: The left front shall have a top center placket 1-1/2" wide with two rows of stitches 7/8" apart. The shirt will have 7 buttons and buttonholes on the front; spacing between each will be 3-3/4" except the spacing between the neck button and the first button on the front, which will be 3-1/4". Top center placket to have woven interlining of #550 Stabilized Mello-Press. Non-woven interlining unacceptable and shall be cause for rejection. The fronts shall be joined to the yoke so that both raw edges of the yoke are turned under, with the front sandwiched between, and then all three are stitched down with a 1/16" raised stitch. Safety stitch joining unacceptable.

3.1.2.4 Shoulder Straps:

SHOULDER STRAP

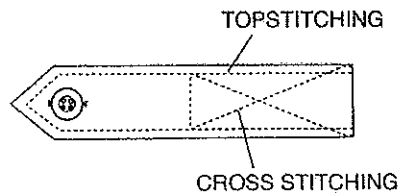

Shoulder straps to be two-piece pointed, 1/4" topstitched and to be set on yoke with leading topstitch conforming with front joining seam. To measure 2" at sleeve tapering to 1-3/8" and set not more than 1/2" from collar set seam. Cross-stitched approximately 2" from sleeve seam. Shoulder strap to have functional buttonhole to attach to sewn button on shoulder of shirt. Edge stitched shoulder strap construction unacceptable.

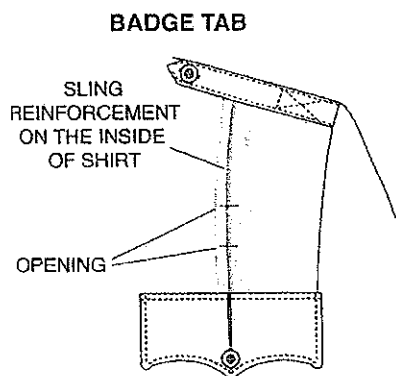

3.1.2.5 Badge Reinforcement:

Two-ply sling 1" wide centered over left pocket and stitched to shoulder seam and flap setting stitch. It shall have 2 (two) buttonhole eyelets 1-1/4" from top of pocket flap spaced 1-1/4" apart and centered on sling.

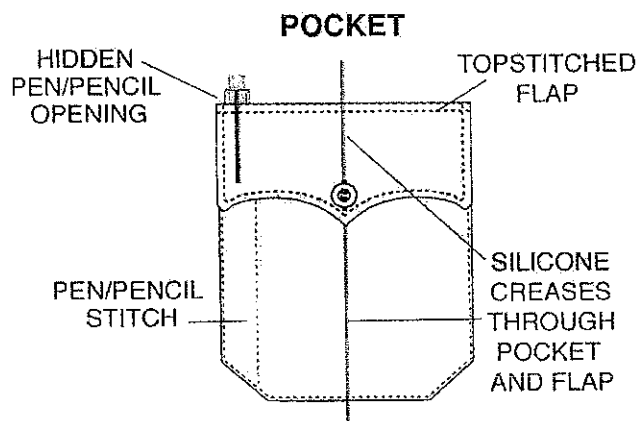

3.1.2.6 Pockets:

Two plain breast patch pockets with mitered corners. Pocket to measure 5-5/8" wide, 6" deep. Left breast pocket to have 1- 1/2" pencil stitch. Each pocket to have hook Velcro, 3/4" long by 1/2" wide, positioned on both edges of pocket to correspond with outer scalloped flap points as specified. Velcro to be stitched all sides and to be sewn through pocket and shirt for added reinforcement.

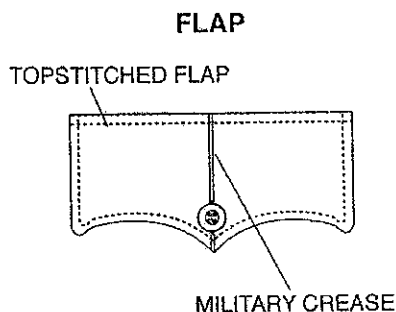

3.1.2.7Flaps: Two piece deep scalloped design to measure 5-7/8" across and 2-3/4" in depth at center point, 2-1/4" at sides. Secured to shirtfront approximately 3/8" above pocket. Left flap to have invisible pencil opening 1-1/2" to correspond precisely with pencil slot of pocket. (Stop & start stitching for pencil opening unacceptable and shall be cause for rejection.) Flaps to be 1/4" topstitched. Flaps to have woven interlining of #550 Stabilized Mello-Press. Creased and edge stitched pocket flap construction unacceptable. Under side of the flap to have looped Velcro 3/4" long by 1/2" wide stitched all sides, positioned on outer points of both pocket flaps to secure with corresponding Velcro strips on shirt pocket. Each flap shall have a button centered on uncut sewn buttonhole.

3.1.2.8Sleeves: Sleeve vent shall be a minimum of 4-1/2" long with one-piece top and bottom facings. Facing to measure 1-1/8" wide point blocked at top.

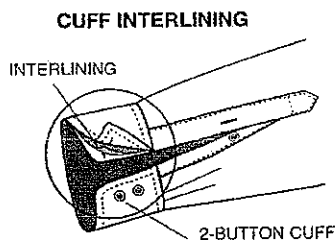

3.1.2.9Cuffs: Two piece 1/2-inch hemmed cuff with 1/4" topstitching. Cuffs to measure 3" in depth with rounded corners (barrel cuffs). Cuffs to have two buttons and corresponding buttonholes set vertically with one button and buttonhole in center of facing. Cuffs to have woven interlining of #550 Stabilized Mello-Press.

3.1.2.10Buttons: First grade 20-ligne melamine.

3.1.2.11Sewing: Collar, shoulder straps, pocket flaps and cuffs to be topstitched 1/4" off the edge. Sleeve inserting and side close felling seams are to be safety stitched.

3.1.2.12Thread: All sewing threads to be color fast polyester wrap to match.

3.1.2.13 Interlinings: Collar interlined with #285 Stabilized Mello-Press. Cuffs, pocket flaps and top center to be interlined with #550 Stabilized Mello-Press. Collar band to be interlined with Crease-N-Tack.

3.1.2.14 Military Creases: There shall be five sharp silicone military creases on all shirts. One crease on each front to be centered vertically. Front creases shall be through pockets and flaps. Spacing for three military creases across shirt back to be proportionate to the size of the shirt.

3.1.2.15 Construction: Collars, flaps and cuffs are made with conventional construction. Top ply, bottom ply and interlining are first stitched together, then turned right side out and finally topstitched.

3.1.2.16 Stock Sizes: Shirts must be available in the following sizes:

Sleeve lengths: 32-37 inches

Neck sizes: 14-1/2 to 18-1/2, 19, 20, 21, 22

3.1.3

Short Sleeve Shirt - Flying Cross Item #96R6691 or equivalent to

65% dacron polyester/35% rayon

Color: Slate Grey

Weight: 10.0 to 10.50 oz / linear yard

3.1.3.1 Style: To be Flying Cross Model 96R6691. Dress style, top center placket front, full cut tapered fit, convertible collar, short sleeves, and dress shirrtail. Two plain breast pockets with topstitched scalloped flaps. Topstitched shoulder straps. Full badge reinforcement. Matching inside yoke of Dacron/Cotton Poplin. Work wear industrial style shirt construction is unacceptable and shall be cause for rejection.

3.1.3.2 Collar: Convertible collar shall be one piece. Collar points to measure 3 1/8" long with ultrasonically fused-in Mylar stays. Collar to have woven interlining of #285 Stabilized Mello-Press. Stays to be 2 1/2" long, 3/8" minimum width, and to be fused to underside of collar interlining. Stays applied directly to collar material itself unacceptable. Collar topstitched 1/4" off the edge. Collar material itself (top or underside) shall have no fusing to Mylar stays or collar interlining.

3.1.3.3 Front: Each front shall have a facing approximately 3" in width. The left front shall have a top center placket 1-1/2" wide with two rows of stitches 7/8" apart. Stitching on top center is not to be visible on the turn-back facing. The shirt will have 7 buttons and buttonholes on the front; spacing between each will be 3-3/4" except the spacing between the neck button and the first button on the front, which will be 2 1/2". Top center placket to have woven interlining of #550 Stabilized Mello-Press. Non-woven interlining unacceptable and shall be cause for rejection. The fronts shall be joined to the yoke so that both raw edges of the yoke are turned under, with the front sandwiched between, and then all three are stitched down with a 1/16" raised stitch. Safety stitch joining unacceptable.

3.1.3.4 Shoulder Straps: Shoulder straps to be two-piece pointed, 1/4" topstitched and to be set on yoke with leading topstitch conforming with front joining seam. To measure 2" at sleeve tapering to 1-3/8" and set not more than 1/2" from collar set seam. Cross-stitched approximately 2" from sleeve seam. Shoulder strap to have functional buttonhole to attach to sewn button on shoulder of shirt. Edge stitched shoulder strap construction unacceptable.

3.1.3.5 Badge Reinforcement:

Two-ply sling 1" wide centered over left pocket and stitched to shoulder seam and flap setting stitch. It shall have 2 (two) buttonhole eyelets 1-1/4" from top of pocket flap spaced 1-1/4" apart and centered on sling.

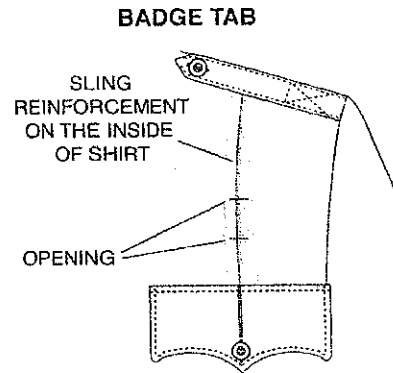

3.1.3.6 Pockets:

Two plain breast patch pockets with mitered corners. Pocket to measure 5-5/8" wide, 6" deep. Left breast pocket to have 1- 1/2" pencil stitch. Each pocket to have hook Velcro, 3/4" long by 1/2" wide, positioned on both edges of pocket to correspond with outer scalloped flap points as specified. Velcro to be stitched all sides and to be sewn through pocket and shirt for added reinforcement.

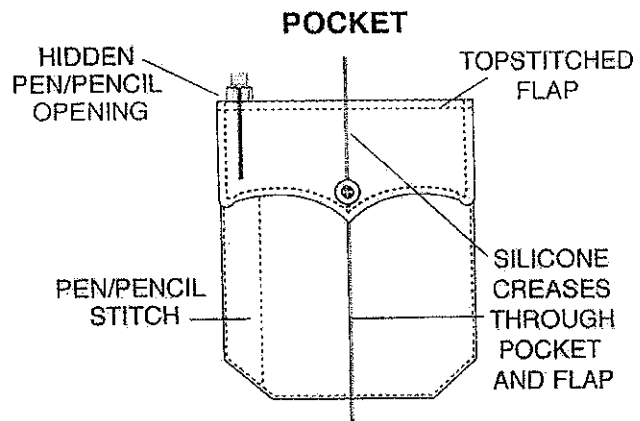

3.1.3.7 Flaps: Two piece deep scalloped design to measure 5-7/8" across and 2-3/4" in depth at center point, 2-1/4" at sides. Secured to shirtfront approximately 3/8" above pocket. Left flap to have invisible pencil opening 1-1/2" to correspond precisely with pencil slot of pocket. (Stop & start stitching for pencil opening unacceptable and shall be cause for rejection.) Flaps to be 1/4" topstitched. Flaps to have woven interlining of #550 Stabilized Mello-Press. Creased and edge stitched pocket flap construction unacceptable. Under side of the flap to have looped Velcro 3/4" long by 1/2"

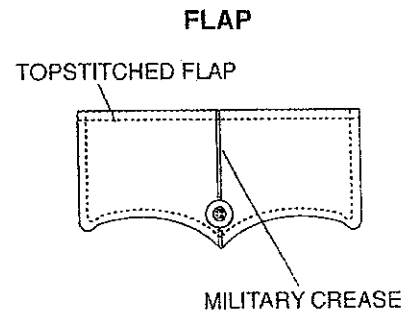

wide stitched all sides, positioned on outer points of both pocket flaps to secure with corresponding Velcro strips on shirt pocket. Each flap shall have a button centered on uncut sewn buttonhole.

3.1.3.8Sleeves: Sleeves are to be straight and whole and to have a ¾" hem and to finish at a minimum of 9½" long from shoulder seam.

3.1.3.9Buttons: First grade 20-ligne melamine.

3.1.3.10Sewing: Collar, shoulder straps and pocket flaps to be topstitched 1/4" off the edge. Sleeve inserting and side close felling seams are to be safety stitched.

3.1.3.11Thread: All sewing threads to be color fast polyester wrap to match.

3.1.3.12Interlinings: Collar interlined with #285 Stabilized Mello-Press. Pocket flaps and top center to be interlined with #550 Stabilized Mello-Press.

3.1.3.13Military Creases: There shall be five sharp silicone military creases on all shirts. One crease on each front to be centered vertically. Front creases shall be through pockets and flaps. Spacing for three military creases across shirt back to be proportionate to the size of the shirt.

3.1.3.14Construction: Collars, straps and flaps are made with conventional construction. Top ply, bottom ply and interlining are first stitched together, then turned right side out and finally topstitched.

3.1.3.15Stock Sizes: Shirts must be available in the following sizes:

Neck sizes: S - 4XL

3.1.4

Product Description	Men's Taclite® Pro Pant or equivalent to
Style Number:	74273, 74273L

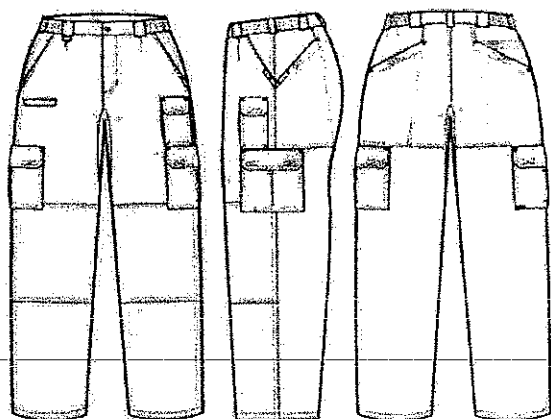

3.1.4.1

Fabric Type:	Main Body:	65% Polyester 35% Cotton TDU® Ripstop 6.14 oz with Teflon® finish
	Pocketing:	80% Polyester 20% Cotton plain weave
	Garment Wash:	Rinse washed for shrinkage control and pleasant hand feel
3.1.4.2		
FEATURES & BENEFITS:	Lightweight version of the authentic 5.11 Tactical Pant	
	Fade and wrinkle-resistant, tough, lightweight, breathable	
	Teflon® treated for spill and stain resistance	
	Front pleat, action waist and a gusseted crotch for enhanced movement	
	7 belt loops with a D-ring below the front right belt loop	
	Deep front pockets with extra reinforcement on knife clipping area.	
	Bellowed cargo pockets with flaps	
	Knife and Cell phone pockets lined with extra durable Cordura Nylon	
	Wearer's right welt knife pocket accommodates the iphone	
	Double seat with large back pockets	
	Patented rear strap and slash pockets	
	Double knees within side opening 10r inserting Neoprene knee pad (sold separately)	
	Bottom hems have openings for draw cords (not supplied)	
3.1.4.3	48 bar tacks in high-stress areas	
STITCHING & FINISHING:	Seams are durable with 10 stitches per inch and extra heavy 5-thread construction.	

3.1.4.4	Top Stitching is non-raveling lock stitching.
3.1.4.5	Double needle top stitching on side seams, seat seams, front rise, fly outline, hand pocket openings, all pockets and pocket flaps and knee patches
3.1.4.6	Bar tacks at crotch point, all belt loop corners, all pocket openings and flaps are cross bar tacked.
3.1.4.7	Box stitching on all Hook and Loop pieces
3.1.4.8	Clean finished pocket bags inside the pant, double stitched for heavy duty
3.1.4.9 CLOSURES	Zipper – Fly zipper is metallic YKK® zipper with auto lock slider. Snap – Waist snap is metallic PRYM® snaps with extra strong grip. Button – Fly has a back-up button for extra security. It is cross tacked Hook and Loop closure on cargo pockets, cell phone pocket and back pockets
3.1.4.10 LABELS	Tactical® Strip label on wearer's right cargo pocket. The woven main label, care label, size label, Country of origin label and fiber content label are permanently attached to the inside of the pant
3.1.4.11 STOCK SIZES:	28-44 waist, even inseams 30-36 and 46-54 unhemmed
3.1.4.12 COLORS:	019 Black, 070 Stone, 120 Coyote, 190 TDU Green, 192 Tundra, 162 TDU Khaki, 724 Dark Navy, 018 Charcoal

3.1.5

Product Description	TaclitePro LS Shirt or equivalent to
Style Number:	72175, 72175T

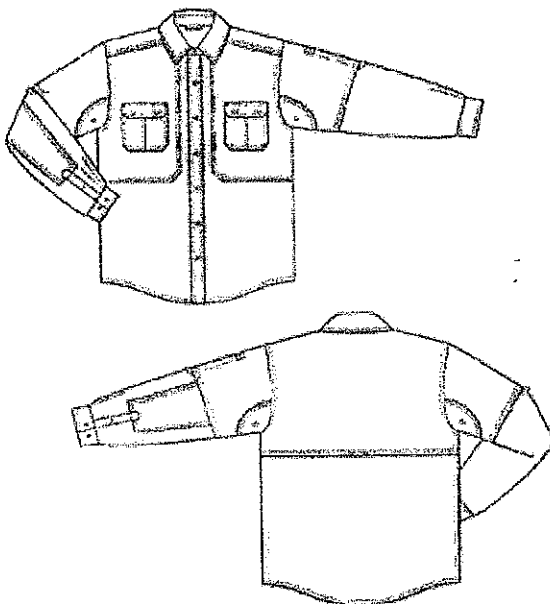

3.1.5.1

Fabric Type:	Main Body:	65% polyester 35% cotton 4.4 oz Taclite® with Teflon finish
3.1.5.2	Lining	100% Polyester Mesh
3.1.5.3FEATURES & BENEFITS:	<p>Polyester cotton blend for a professional appearance and comfort Teflon® finish for stain resistance Large horizontal back vent lined with mesh that has good wicking properties Locker loop at inside back neck Collar features hidden button-down tabs Two bellowed chest pockets and pencil pocket openings on each flap Double pencil pocket on wearer's left sleeve 5.11 patented hidden document pocket Comes with an epaulette and badge holder kit for easy conversion Stitched eyelets arm pit vents that are reinforced for stability Professional cuff strap feature at four rolls of the sleeve Double fabric for added elbow durability</p>	
3.1.5.4STITCHING	Seams are durable with 10-12 stitches per inch on all operations	

<p>& FINISHING:</p> <p>3.1.5.5</p>	<p>Triple needle stitching on the armholes, armhole patches, front yoke, back cape, document pocket, pocket bags, both sides of center front placket, elbow patch, collar and cuff edges</p> <p>Double needle topstitching on pocket flaps, sleeve hems and clean finished shirt tail</p> <p>2 Vertical bar tacks on each of the pocket flaps spaced 1 1/2" apart for the pen pocket opening</p> <p>Bar tacks at top corners of pocket flaps and chest pockets, top and bottoms of document pocket openings and at center back of cape</p>
<p>3.1.5.6 CLOSURES</p>	<p>Buttons – 4 hole Melamine buttons that won't melt, burn, or crack</p> <p>20 Ligne Buttons:</p> <p>1 at center front neck band, 6 buttons on front placket, 2 buttons on each cuff for adjustability, 1 on each sleeve placket, 1 spare button and 2 buttons provided for optional epaulettes</p> <p>14 Ligne Buttons:</p> <p>2 buttons at hidden button-down tab, under collar</p>
	<p>1 spare</p> <p>Hook and loop closure on document pockets and chest pockets</p>
<p>3.1.5.7 LABELS</p>	<p>Parts @ label, woven logo label, care label, size label, country of origin label and fiber content label are permanently attached to the inside of the shirt</p>
<p>3.1.5.8 STOCK SIZES:</p>	<p>S-3XL Regular</p> <p>L-5XL Tall</p>
<p>3.1.5.9 COLORS:</p>	<p>019 Black, 162 TDU Khaki, 724 Dark Navy in Reg and Tall</p> <p>010 White, 190 TDU Green, 018 Charcoal in Reg only</p>

3.1.6

PRODUCT DESCRIPTION:

Taclite® Pro SS Shirt or equivalent to

STYLE NUMBER:

71175, 71175T

3.1.6.1 FABRIC TYPE:

Main Body: 65% polyester 35% cotton 4.4 oz Taclite® with Teflon finish

Lining: 100% Polyester Mesh

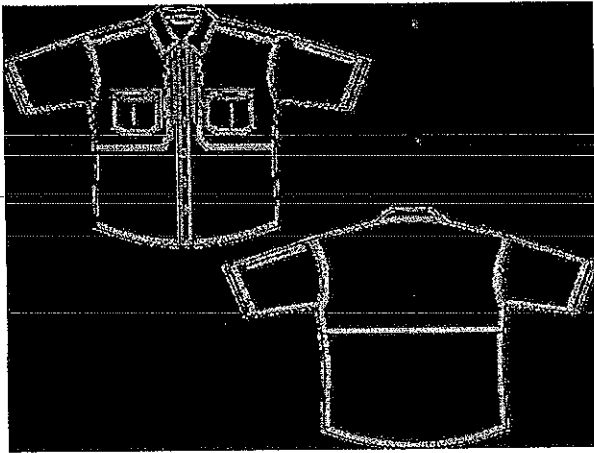

3.1.6.2 FEATURES & BENEFITS:

Polyester cotton blend for a professional appearance and comfort

Teflon® finish for stain resistance

Large horizontal back vent lined with mesh that has good wicking properties

Locker loop at inside back neck

Collar features hidden button-down tabs

Two bellowed chest pockets and pencil pocket openings on each flap

Double pencil pocket on wearer's left sleeve

5.11 patented hidden document pocket

Comes with an epaulette and badge holder kit for easy conversion

3.1.6.3 STITCHING & FINISHING:

Seams are durable with 10-12 stitches per inch on all operations

Triple needle stitching on the armholes, front yoke, back cape, document pocket, pocket bags, both sides of center front placket and collar edge

Double needle topstitching on pocket flaps, sleeve hems and clean finished shirt tail

2 Vertical bar tacks on each of the pocket flaps spaced 1 1/2" apart for the pen pocket opening

Bar tacks at top corners of pocket flaps and chest pockets, top and bottoms of document pocket openings and at center back of cape

3.1.6.4 CLOSURES:

Buttons – 4 hole Melamine buttons that won't melt, burn, or crack

20 Ligne Buttons:

1 at center front neck band, 6 buttons on front placket, 1 spare button and 2 buttons provided for optional epaulettes

14 Ligne Buttons:

2 buttons at hidden button-down tab, under collar

1 spare

Hook and loop closure on document pockets and chest pockets

3.1.6.5 LABELS:

Parts # label, woven logo label, care label, size label, country of origin label and fiber content label are permanently attached to the inside of the shirt

3.1.6.6 STOCK SIZES:

S-3XL Regular

L-5XL Tall

3.1.6.7 COLORS:

019 Black, 162 TDU Khaki, 724 Dark Navy in Reg and Tall

010 White, 190 TDU Green, 018 Charcoal in Reg only

3.1.7

Hats (with PSC Patch that is not silk-screened): - or equivalent to

3.1.7.1 HTT Style #930 or equal to - 6 panel low profile twill cap in Black.

Shall be 6 panel, heavy blended cotton twill 14 x 14/90 x 52 cap with self fabric, velcro closure & pre-curved visor, low profile and structured (crown length 17.2 cm)- PSC emblem sewed on the front - price with patches on them

3.1.7.2 Patches - (We use Silking at the present time) Must be sewn on by vendor - price separately and provide price for sewn on clothing - to be the same size and design as presently worn by the Division.

- a. USA Gold Flag
- b. PSC Large emblem
- c. PSC Small emblem for caps
- d. PSC pipeline safety patch

A copy of our PSC patch is attached - background color of patch should match pants (Oxford Grey) with gold metallic thread trim. The final design can be discussed further after award has been made.

3.1.8

Bates - Chukka Boot w/buckle- Style 83 or equivalent to

3.1.8.1Upper Material: HM weight 4 to 4.5 oz, Leather. Easy care and easy maintenance.

3.1.8.2Upper Lining: Cambrelle®, two-ply fused nylon on 1/8" foam for cushioning and comfort.

3.1.8.3Ornaments: 7/8", #225 buckle for ornamentation.

3.1.8.4Boxtoe: 30 Knilon Core.

3.1.8.5Counter: VHC 50, skived edges.

3.1.8.6Insole: 3 1/2 Iron Texon®, #428, pressed fiberboard for maximum support.

3.1.8.7Shank: TF 21, Fiberglass shank for instep support from heel to ball of foot.

3.1.8.8Bottom Filler: 3/16", 7 ounce poly-foam placed inside rib radius for extra cushioning.

3.1.8.9Midsole: 5 Iron Black Hi Tech for cushioning and shock absorption. Stitched to welt with #7 Cord Black Cotton Braid for durability.

3.1.8.10Outsole: Polyurethane with attached heel. Comfortable, long wearing, skid and oil-resistant unit.

3.1.8.11Insole Insert: Durashock II, Dual Density Polyurethane Sock Insert with Shock Absorbing heel and forepart pads. Breathable and replaceable insert resists odor and mildew with foot hugging comfort.

3.1.8.12Upper Finish: Cleaned and conditioned and buffed to a satin shine. Wrapped in tissue and packed in corrugated, die cut boxes.

3.1.8.13In Line Sizes: Men's B 3-9 D 3-12 E/EEE 7-12,13

3.1.9

Bates Lites Uniform Oxford shoes - Black - Style 932 - Men's 5-eye Leather Oxford (Welted) or equivalent to**FEATURES**

3.1.9.1Upper: Black cowhide leather

3.1.9.2Upper Lining: Drilex camo

BENEFITS

- Easy care
- No breaking in
- Polishable to a lusture shine

- Breathable
- Absorbs perspiration
- Resists odor and mildew
- Soft cushioning

- | | |
|---|--|
| 3.1.9.3 Eyelets: # 115 Blind Nickle | -Rust Resistant
-Secure |
| 3.1.9.4Boxtoe: Thermo-Plastic | -Shapes toe of shoe
-Minimal toe protection |
| 3.1.9.5Counter: Thermo-plastic | -Heel Shaping and adds support. |
| 3.1.9.6Insole: 3 1/2 Iron texon | -Strong foot support.
-Quick drying |
| 3.1.9.7Insole Insert: Durashock II with dual density Polyurethane & shock absorbing Heel and forepart pads. | -Comfort cushion
-Removable and replaceable
-Breathable
-Absorbs odor and resists mildew |
| 3.1.9.8Shank: Fiberglass | -Instep support from heel to ball Of foot. |
| 3.1.9.9Welt Construction | Goodyear Storm welt, provides lateral and Longitudinal support for Maximum foot comfort.
-Enables sole to be replaced when worn down.
-Nylon braided cotton for additional strength. |
| 3.1.9.10Outsole: Polyurethane with attached | -Lighter and cooler than rubber heel
-Long wearing
-Oil resisting
-Skid resistant
-Non marking
-Adds spring and cushion to every step. |
| 3.1.9.11Sizes : C 9 -12,13
D/E 6 - 12,13, 14
EEE 7 - 12, 13 | |

3.1.10

Danner Striker GTX 8" Weatherproof Boot – Black – Gortex 42919- Insulated Boots or equivalent to

3.1.10.1 Shall be 100% waterproof and breathable GORE-TEX® liner is engineered to keep your feet dry and comfortable - even in extreme conditions

3.1.10.2 Shall be 400 grams of Thinsulate™ Ultra Insulation offer lightweight warmth for those needing protection in cold climates

Full-grain leather can be easily polished and is preferred by those in uniform and on special tactical teams due to its durability and ability to be cleaned quickly

1000 Denier nylon upper material is extremely resistant to abrasions, tears, and scuffs, improves breathability, and dries quickly

TERRA FORCE™ X Lite platform provides lightweight, durable traction, heel-to-toe energy transfer, side support to enhance maneuverability, and protection from arch overwork and fatigue

Danner TFX® Lite outsole is an oil- and slip-resistant outsole that gives you grip, traction and stability without the weight

3.1.10.3 Shall have Nylon shank

3.1.10.4 Shall be 8" height Extremely lightweight at 50 oz

3.1.11

Stetson Campaign Style Hat or equivalent to

Black - Style F-40 – Stratton

Felt and Straw with Rain Cover

Traditional four dent style, metallic dyes used are capable of withstanding

100 hours of fade-o-meter testing. The triple thick and extra stiff flat

brim comes in 3" width. Single vent eyelet located on sides and back.

3.1.12

Safariland Duty Belt

General Description

2 1/4" wide duty belt to carry law enforcement equipment to include duty holster and accessory gear.

3.1.12.1 Product Function

Maintains duty holster and accessory gear in a stable, tactically ready configuration. Attaches to under belt by means of belt keepers, if desired, for added stability. Fastens around the waist by the hook end latching into the double tongue buckle and the belt stud being placed in one of the center holes.

3.1.12.2 Construction Materials

7-8 oz. vegetable tanned black died through shoulder leather with firm tan process provides the inside layer or structural base of the belt. This base is encased by engineered materials. The inner layer is lined with a green mossback suede. Internal stitching is done with #207 nylon cord. External stitching is done with #277 nylon cord. A belt hole stud is inserted 2 1/4" from the hook bar which is stitched into the tab end of the belt to keep buckle attached to hook assembly. The double tongued buckle is an additional fastening device. Co-polymer sheeting is inserted into the tab end for reinforcement.

3.1.12.3 Available Finishes

Plain, Basketweave, Hi-Gloss, Nylon Look - Black.

3.1.12.4 Manufacturing Process

The engineered material and thermo molded co-polymer material recombined with heat and pressure to bond together into one complete unit. Green mossback suede is stitched on the inner layer with #277 cord.

(Average size 38) Dimensions and weights may vary for each belt size. Duty belts are manufactured 2" (50mm) oversize to accommodate the under belt.

3.1.12.5 Dimensions and Weights:

	<u>Imperial</u>	<u>Metric</u>
Weight:	1.06 lbs.	480.80 gr
Length:	48 ¾"	123.81 cm
Height:	¼"	.635 cm
Width:	2 ¼"	5.715 cm

Quality Control

ISO 9001 Societe Generale de Surveillance – ANSI RAB Registrar AQS Quality Procedures.

3.1.13

**Fechheimer Flying Cross Spectrum Ultimate Coat - Style #78141 or equivalent to
Color: Black**

3.1.13.1 OUTER SHELL:

SUPPLEX SUPREME WARP: 70 Denier Nylon FILLING: 3 ply 70 Denier Nylon WEIGHT: 3.6 oz. per square yard WEAVE: Plain TEAR STRENGTH: Warp-9.0 lbs. Filling-8.0 lbs. TENSILE STRENGTH: Warp-200 lbs. Fill-150 lbs. ABRASION (4LB. DIAPHRAM, 1LB HEAD LOAD): 300 COLOR: BLACK

3.1.13.2 LINING:

Must be Gore-Tex LTD liner from W. L. Gore (no substitutes). The waterproof breathable lining shall conform to the following requirements:

3.1.13.3 LINING INFORMATION:

Base material to be 2 layer. Top lay to be Fabric: 100% Black Polyester, and bottom layer to be bi-component expanded polytetrafluorethylene membrane. Lining shall have following minimum physical properties:

CHARACTERISTIC	REQUIREMENT	TEST METHOD
Moisture Vapor Transmission Rate (g/m²/24hr) Procedure B Procedure BW	700 Minimum 6,500 Minimum	ASTM E 96-93 <u>1/</u> ASTM E 96-93 <u>2/</u>
Hydrostatic Resistance (psi)	140 Minimum	FED-STD-191A 5512 <u>3/</u>
Low Pressure Water Permeability:		
Initial	No Leakage	FED-STD-191A 5516 <u>4/</u>
After Cold Flex Warp Fill	No Leakage No Leakage	ASTM D 2097-69 (1980) <u>5/</u>
After 100 Hours of Continuous Wet Flex (agitation)	No Leakage	FED-STD-191A 5516 <u>6/</u>
After Dry Cleaning	No Leakage	FED-STD-191A 5516 <u>7/</u>
High Pressure Water Permeability:		
Initial	No Leakage	BS3424:Part 26: 1990 Method 29A8/
After exposure to Unleaded Gasoline, Deet insect repellent, Hoppes #9 Gun Cleaner, Motor Oil SAE 15W-40	No Leakage	BS 3424:Part 26:1990 Method 29A <u>9/</u>
After Synthetic Perspiration	No Leakage	BS 3424: Part 26: 1990 Method 29A <u>10/</u>
Seam Tape Durability		
Initial	No Leakage	FED-STD-191A5516 <u>11/</u>

After 10 Laundry Cycles	No Leakage	FED-STD-191A5516 <u>12</u> / ANSI/AATCC 135
After 10 dry Clean Cycles	No Leakage	FED-STD-191A 5516 <u>13</u> /

3.1.13.4BASIC STYLING:

Waist length, single breasted, black Gore-Tex LTD breathable waterproof lining, removable Thinsulate body/sleeve liner, and front zipper storm front closure. Other features include a bi-swing back, raglan sleeves, sleeve zippers, pocket flaps, inverted pleated patch pockets with hand warmer openings, collar, knit wind collar, shoulder straps, badge tab, and zippered side vents with tab.

There shall be a zip-out insulated liner that incorporates CDS-200 Thinsulate® Thermal Insulation in the body portion of the liner and CDS-100 Thinsulate Thermal Insulation in the sleeves. The insulation shall be quilted to black 86 pick nylon on the face side of the liner and nylon tricot on the backing. There shall be black knit inserts placed under the arm of the liner sleeves approximately 9" in length and 3 1/2" at widest center point for comfort and ease of movement. The liner will attach to the jacket with a grip-lock non-run zipper.

3.1.13.5SHELL FOR REMOVABLE LINER:

86 pick 100% Nylon Taffeta WEAVE: Plain DENIER: Warp-70 Fill-70 WEIGHT: 1.8 oz./square yard
COLOR : Black (any other shade is cause for rejection).

3.1.13.6INSULATION:

3M Thinsulate, with a scrim covering front and back to prevent migration of insulation fibers. Lining must be quilted horizontally with a minimum of a 6" railroad pattern for maximum thermo retention. Excess stitching and openings in liner cause extreme loss of body heat.

3.1.13.7BODY:

Body - 3M Thinsulate CDS 200 composed of 65% Polyolefin microfibers and 35% 6 Denier Polyester staple fibers (by weight) Shall weigh approximately 200 grams/square meter horizontally quilted

3.1.13.8SLEEVES:

Sleeves - 3M Thinsulate CDS 100 composed of 65% Polyolefin microfibers and 35% 6 Denier Polyester staple fibers (by weight). Shall weigh approximately 100 grams/square meter horizontally quilted. The perimeter of the liner shall be bound with black nylon taffeta tape and the liner shall have a black vislon zipper track to allow the liner to zip out of the jacket.

The liner sleeves will have a female snap by the insleeve seam no more than 1" from the end of the sleeve. Attached to the jacket sleeve in a corresponding location will be a tab made of shell material with a male snap. The tab and snap are used to secure the liner sleeves - use of a button and buttonhole

or loop is unacceptable. The liner shall have a left breast patch pocket. Each sleeve hem must be finished with bias tape so there are no raw edges.

The liner shall be designed with vents corresponding with the zippered side vents on the jacket to allow easy access to weapon or equipment.

3.1.13.9BACK:

There shall be a one piece back with a bi-swing for ease of movement. The bi-swing shall be approximately 9" in length and 1 1/2" in depth. It shall be constructed with an elasticized anchor so the bi-swing will snap back into proper position after being extended. It shall be constructed with an elasticized anchor made of a 2" wide strip of Lycra so the bi-swing will snap back into proper position after being extended.

3.1.13.10INTERLINING:

100% Cotton Osaburg, 3.45 yards/lb. with maximum shrinkage of 3-4% in warp and fill. Interlining to be used in collar, pocket flaps, shoulder straps, front waistband, and storm front.

3.1.13.11POCKETS:

There shall be an inverted pleated patch pocket on each front of the jacket. The pockets shall be approximately 7 1/2" wide and 8" in depth. Pockets shall be constructed with hand warmer openings on the side. The surface portion of the hand warmer pockets will be the jacket front and the top part of the pocket (the area coming in contact with the back of the users hand) will be black Kasha. The top and bottom of the side openings shall be securely bar tacked.

The patch pockets will have an opening at the top underneath the flaps. The top of each patch pocket must be bound with black nylon binding. The top entry pockets shall be made of black Kasha. Back of box pleated patch pocket must be fully lined.

The left front pocket will have a pencil compartment opening on the inside corner of the pocket flap. The opening will be reinforced by bar tacks.

The pocket flaps shall have a metal snap closure system. The male portion of the snaps shall be located on the underside of each flap and the female portion of the snaps shall be in a corresponding location on the breast pockets to provide a neat and secure closure. Each flap shall have a dummy buttonhole with a 24 ligne metal button on top of the flap attached with a kotter key on the bottom side of the flap.

3.1.13.12POCKETS:

The jacket design will include an inside left breast pocket. The pocket shall have a minimum width of 6" and a minimum depth of 8 1/4" (measured from the bottom of the pocket opening). The inside pocket will incorporate a zipper closure system utilizing a 6" CFC-256B2 zipper that is made with bottom stops at both ends.

3.1.13.13ELASTIC WAISTBAND:

Separate waistband shall be elasticized in the back. There shall be two rows of stitching each 1/2" apart, centered on the waistband, and extending through the elastic. The elastic shall be securely tacked at each end. There will be a zipper sewn into each side for access. Elasticized tabs shall be sewn into the

waistband for closure of the side tab. There shall be two (2) belt keeper tabs, with sewn eyelets, made of shell fabric and located approximately 2" from back zipper side vents.

3.1.13.14SLEEVES:

Three piece, raglan style sleeves with cuffs. The top half of the cuff must be elasticized and the bottom half to close with a tab and double snap for cuff adjustment. The sleeves shall be constructed with 7" zippers (black vislon) on the underseams. This system permits emblem attachment without puncturing the Gore-Tex by allowing access to the shell.

3.1.13.15COLLAR:

The collar shall be produced using two plies of the shell fabric plus the interlining. All plies to be cut on bias. The interlining shall be sewn to the undercollar. The collar points shall be well shaped and symmetrical. The front storm flap shall extend to the top of the collar. Collar and collar interlining must be cut on bias. Under collar is to be constructed to conceal a removable Gore-Tex Hood.

3.1.13.16EPAULETS:

Jacket shall be designed with epaulets measuring approximately 2 1/2" at the widest point and tapering to 1 3/4" at the narrow end. It shall be fastened with a 24 ligne metal uniform button and buttonhole. Shoulder strap to be cross stitched and sewn down.

3.1.13.17STORM FLAP:

There shall be a double front storm flap; one on top and one under the top storm flap. The top storm flap will finish approximately 2 3/4" wide and will extend from the bottom of the waistband to the top of the collar point. There shall be six (6) black gun metal snaps centered down the top storm flap. The under storm flap shall finish approximately 2" wide and will extend from the bottom of the waistband to the top of the collar point. The male portion of the snaps shall be positioned on the under storm flap to correspond to the placement of the snaps on the top storm flap to provide a neat and secure closure. Center of snap to be plugged, concealing open portion of snap.

3.1.13.18SIDE VENTS:

The jacket shall be designed with side vents to allow for easy access to equipment. The vents shall incorporate 10" zippers. At the bottom of each vent there shall be an elasticized tab and snap closure system to prevent gaping between the front and rear portion of the jacket when the side zippers are in the full upward position.

3.1.13.19WEEP EYELETS:

Shall have black metal weep eyelets located at bottom of sleeve (both panels) and front & back body panels.

3.1.13.20BADGE TAB:

To be made of self material with two metal eyelets. The bottom of the badge tab shall be 2 1/4" - 2 1/2" above the left pocket flap.

3.1.13.21FRONT ZIPPER:

The front zipper opening shall be accomplished with a two way pull, heavy duty #5 Vislon nylon molded zipper. Zipper will extend from bottom of waistband to collar seam.

3.1.13.22KNIT WIND COLLAR:

There shall be a knit wind collar of 1 x 1 ribbed spun nylon sewn into the collar seam - measuring 14" long by 1½" wide at the center.

3.1.13.23SEAM WATERPROOFING:

Seams shall be taped with 7/8" two layer Gore seam tape. There shall be no stitching through the LTD liner except those seams that are waterproofed. There will be metal eyelets on the sleeve bottoms and above the front and back waistband, for water drainage in laundering.

3.1.13.24SIZE TAG AND CARE INSTRUCTIONS:

The jacket shall have a sewn in label giving care instructions and a permanent woven size tag. The jacket shall also have a label indication lot number, size, fiber content, and RN number. Garment must be made in the United States Of America and bear a union label.

3.1.13.25SIZE RANGE:

The jacket must be available in the following sizes:

Regular: S-XXXL
Short: S-L
Long: S-XXX

LIMITED WARRANTY:

The sample and contract garments shall carry a manufacturers printed warranty hang tag must accompany the bid package as well. The tag shall instruct the owner of their rights under the warranty.

LIMITED WARRANTY:

The Limited warranty shall contain at minimum the following:

Warranty coverage: Manufacturer agrees to warrant to the original purchaser that the product will be free from defects in materials and workmanship for a period of three (3) years from date of purchase. This warranty also guarantees the jacket will remain waterproof for three (3) years

Warranty service: Should a covered product become defective during the warranty period, simply return it to the manufacturer with dated proof of purchase. The manufacturer agrees to repair or replace at its option any item determined to be defective and will return to purchaser at no charge

Limitations: This warranty does not cover abnormal wear and tear, nor the color fastness of fluorescent fabrics, nor damage from chemicals, fire, misuse, accident or negligence. This warranty only applies to the original purchaser of the covered product and is not transferable.

New Entrant Program Clothing:

3.1.14

Short Sleeve Shirt S200-CBL Short Sleeve Shirt or equivalent to

- 3.1.14.1Fabric: 4.5 ounce 100% cotton ring spun chambray, prewashed button up shirt.
 3.1.14.2Color: Blue Chambray
 3.1.14.3Collar: Button down Collar with a separate band and button closure
 3.1.14.4Pockets: Two Chest pockets with mitered flaps and button closures:
 3.1.14.5.Design: Back yoke with box pleat.
 3.1.14.6Stitching: Triple-needle stitched at the main seams

3.1.15

Long Sleeve Shirt S202-CBL Long Sleeve Shirt or equivalent to

- 3.1.15.1Fabric: 4.5 ounce 100% cotton ring spun chambray, prewashed button up shirt.
 3.1.15.2Color: Blue Chambray
 3.1.15.3Collar: Button down Collar with a separate band and button closure
 3.1.15.4Pockets: Two Chest pockets with mitered flaps and button closures:
 3.1.15.5Cuffs: Two button adjustable cuffs with extended plackets.
 3.1.15.6Design: Back yoke with centered box pleat
 3.1.15.7Stitching: Triple needle stitching at main seams

3.1.16

Jackets 411622 Cotton Trades Jacket, light wt. medium wt. heavy wt or equivalent to

- 3.1.16.1Color: Tan, Brown
 3.1.16.2Shell: 90% polyester/ 10% nylon
 3.1.16.3Lining: 100% nylon
 3.1.16.4Closure: Zipper front
 3.1.16.5Collar: Fold over Collar
 3.1.16.6Sleeve: 2 button long sleeve
 3.1.16.7Pockets: front side pockets

3.1.17

Belt: 102 Mark Wolf Brown Belt plain belt or equivalent to

- 3.1.17.1Width: 1 ¼" casual belt.
 3.1.17.2Style: Casual belt
 3.1.17.3Material: Oil Tanned top grain brown leather, domed edges.
 3.1.17.4Buckle: gold dress buckle, with snaps.

3.1.18

Pants 405-810003 Tan Dockers , denim carrhart or equivalent to

- 3.1.18.1Fabric: Individual fit waist band, comfort waste band. Shall Have a permanent crease, no wrinkles, hand & machine washable, 100% cotton.
 3.1.18.2Color: Tan and denim color
 3.1.18.3Closure: Hook & eye front closure with inside button ¼ from the top.
 3.1.18.4Pockets: Have front pockets and Double Welt button through back pockets.
 3.1.19.5Label: enternal fit label Dockers Wing and anchor embroidered brand mark.
 Seam on seam tri-fold.

3.1.19**Shoes MWT-11 Rockport shoes K70884 or equivalent to**

- 3.1.19.1 Style:** Lace shoe. Padded tongue for comfort.
3.1.19.2 Upper: Full grain brown leather that is soft, supple and flexible.
3.1.19.3 Sole: Rubber sole provides durable grip.
3.1.19.4 Insole: EVA that provides light shock absorption to reduce foot and leg fatigue.

3.1.20**Boot 414 Redwing Boot Style Men 8" boot or equivalent to**

- 3.1.20.1 8" upper:** Full grain, waterproof dark brown gambler leather
3.1.20.2 Foot Bed: Red bed featuring Agion anti microbial treatment
3.1.20.3 Shank: Fiberglass
3.1.20.4 Last: 694
3.1.20.5 Construction: Super sole welt Rating ASTM F2892-11 EH
3.1.20.6 Care: Leather protector, natural seal.

Rail Safety Program

PANTS**3.1.21****74273 Men's Taclite Pro Pant or equivalent to**

- 3.1.21.1 Fabric:** 6.14 oz., 65% polyester/35% cotton ripstop.
Teflon treated for soil and stain resistance.
- 3.1.21.2 Pockets:** Trademarked rear strap and slash pockets.
Quick-access multipurpose pocket.
- 3.1.21.3** Double-reinforced seat and knees.
Fade and wrinkle-resistant.
Genuine YKK zippers, Prym snaps
- 3.1.21.4 Color:** TDU Green

3.1.22**74003 Men's Ripstop TDU Pant or equivalent to**

- 3.1.22.1 Fabric:** 7.5-oz. ripstop, smooth-finish 7.25-oz. twill
65% poly/35% cotton
Teflon treated for stain and soil resistance
- 3.1.22.2 Pockets:** Cargo pockets with built-in dividers
- Double-reinforced seat and knees
Self-adjusting comfort-waist
- 3.1.22.3 Color:** TDU Green

3.1.23**64360 Women's Taclite Pro Pant or equivalent to**

3.1.23.1Fabric: 6.14 oz., 65% polyester/35% cotton ripstop.
Teflon treated for soil and stain resistance.

3.1.23.2Pockets: Trademarked rear strap and slash pockets.
Quick-access multipurpose pocket.

Fade and wrinkle-resistant.

3.1.23.3Color: TDU Green

3.1.24**64359 Women's Ripstop TDU Pant or equivalent to**

3.1.24.1Fabric: Polyester-cotton ripstop
Teflon treated for stain and soil resistance

3.1.24.2Pockets: Cargo pockets with integral Back-Up Belt System

Self-adjusting comfort-waist

3.1.24.3Color: TDU Green

SHORT SLEEVE SHIRT**3.1.25****71175 Men's Short Sleeve Taclite Pro Shirt or equivalent to**

3.1.25.1Fabric: 4.4 oz. poly/cotton ripstop fabric, lightweight, breathable and fast-drying
Teflon treated for soil and stain resistance

3.1.25.2Color: TDU Khaki

3.1.25.3Collar: Hidden button down collar

3.1.25.4Pockets: 5.11's patented hidden document pockets

3.1.26**61165 Women's Short Sleeve Performance Polo or equivalent to**

3.1.26.1Fabric: 6.7-oz jersey knit of 100% polyester

3.1.26.2Color: Silver Tan

LONG SLEEVE SHIRT**3.1.27****72175 Men's Long Sleeve Taclite Pro Shirt or equivalent to**

- 3.1.27.1Fabric:** 4.4 oz. poly/cotton ripstop fabric, lightweight, breathable and fast-drying Teflon treated for soil and stain resistance
- 3.1.27.2Color:** TDU Khaki
- 3.1.27.3Collar:** Hidden button down collar
- 3.1.27.4Cuffs:** Long sleeve has adjustable cuffs
- 3.1.27.5Pockets:** 5.11's patented hidden document pockets

3.1.28**62070 Women's Taclite Pro Long Sleeve Shirt or equivalent to**

- 3.1.28.1Fabric:** 4.4 oz. poly/cotton ripstop fabric Teflon treated for soil and stain resistance
- 3.1.28.2Color:** TDU Khaki
- 3.1.28.3Collar:** Collar stays
- 3.1.28.4Sleeves:** Sleeve Keepers
- 3.1.28.5Pockets:** Hidden document pockets

JACKET**3.1.29****48032 Aggressor Parka or equivalent to**

- 3.1.29.1Color:** Tundra
- Waterproof-breathable, seam-sealed construction
Matching removable fleece jacket included with parka
- 3.1.29.2Hoods:** Zip-off hood that stows in the collar and zippered sides with snaps.
- Hidden ID panels that can be customized
Back-Up Belt System compatible
- 3.1.29.3Women:** Must meet specifications and quality of the 48032 Aggressor Parka.

UNDER ARMOUR SHIRTS**3.1.30**

Style No. 1216028 - Men's UA HeatGear Tactical Shortsleeve T-Shirt or equivalent to

3.1.30.1Fabric: 3.5 oz. Polyester
4-way stretch anti-pick, anti-pill material

3.1.30.2Color: Desert Sand

3.1.31

Style No. 1216029 - Men's UA HeatGear Tactical Longsleeve T-Shirt or equivalent to

3.1.31.1Fabric: 3.5 oz. Polyester
4-way stretch anti-pick, anti-pill material

3.1.31.2Color: Desert Sand

3.1.32

Style No. 1216005 - Men's UA ColdGear Tactical Longsleeve Crew or equivalent to

3.1.32.1Fabric: 6.6 oz. Nylon/Polyester/Elastane
Double-Knit GoldGear fabric
Brushed poly interior with nylon exterior
4-way stretch

3.1.32.2Color: Desert Sand

3.1.33

Style No. 1201259 - Women's HeatGear Shortsleeve T-Shirt or equivalent to

3.1.33.1Fabric: 5 oz. Cationic Polyester/Elastane
4-way stretch

3.1.33.2Color: Black

3.1.34

Style No. 1209401 - Women's UA HeatGear Fitted Longsleeve Shirt or equivalent to

3.1.34.1Fabric: Polyester/Elastane
4-way stretch

3.1.34.2Color: Black

3.1.35

Style No. 1212171 - Women's ColdGear Fitted Longsleeve Crew or equivalent to

- 3.1.35.1Fabric: 7.0 oz. Polyester/Elastane
4-way stretch
3.1.35.2Color: Black

UNDER ARMOUR LEGGINGS

3.1.36

Style No. 1216004 - Men's Tactical ColdGear Compression Leggings or equivalent to

- 3.1.36.1Fabric: 6.6 oz. Nylon/Polyester/Elastane
3.1.36.2Color: Desert Sand

3.1.37

Style No. 1221968 - Women's UA ColdGear Compression Leggings or equivalent

- 3.1.37.1Fabric: Polyester/Elastane
3.1.37.2Color: Black

UNDER ARMOUR HOOD

3.1.38

Style No. 1223223 - UA ColdGear Hood or equivalent to

- 3.1.38.1Fabric: Polyester/Elastane, Double-knit
3.1.38.2Color: White

BOOTS

3.1.39

Style Nos. 69220 and 69230 - Danner APB or equivalent to

- 3.1.39.1 Features: Durable full-grain leather, topped in breathable 1000 Denier nylon upper
100% waterproof GORE-TEX CROSSTECH lining
Vibram 1276 Sierra outsole to provide traction in diverse terrain
Fastened with speed laces securely fit down to the toe
- 3.1.39.2Sole: Sewn-in sole (not molded)
- 3.1.39.3Last: 850
- 3.1.39.4Lining: Crosstech
- 3.1.39.5Shank: Nylon
- 3.1.39.6Color: Black
- 3.1.39.7Specs: No. 69220 - Men's 8", 67 oz., Uninsulated, PT
No. 69230 - Men's 8", 69 oz., Thinsulate Ultra, PT

3.1.40

Women Must meet specifications and quality of Style Nos. 69220 and 69230,
Danner APB or equivalent to

Gas Pipeline Section-**3.1.41**

**ITEMS MUST DISPLAY FR TAGS AND BE CERTIFIED TO MEET NFPA 70E LEVEL
HRC-1 OR HRC-2 or EQUIVALENT**

3.1.41.1 Flame Resistant Treated Cotton Long Sleeve Shirts

3.1.41.2 Flame Resistant Treated Cotton Khaki Pants

3.1.41.3 Flame Resistant Treated Denim Pants

3.1.41.4 Flame Resistant Treated Coverall

3.1.42**Handcuffs**

Smith and Wesson – SKU 350135 or equivalent

3.1.42.1 General Description

Handcuff shall have push pin double locking system in a satin nickel finish. Fabricated from the finest quality carbon steel. They are manufactured with heat treated internal lockworks, featuring smooth ratchets for swift cuffing and double locks to prevent tampering.

3.1.43 Safariland Duty Gear Technical Specification Package Model 190 and 190H**General Description**

Shall have Tapered duty handcuff pouch designed to carry one pair of standard (190) and hinged (190H) handcuffs of a peerless or Smith & Wesson style. For use on 2 - 2 ¼" (50-58 mm) duty belts.

3.1.43.1 Product Function

Shall Carry one pair of standard handcuffs in a stable, tactically ready configuration. Cuffs ride with locking mechanism at the bottom. Flap closure device snaps over cuffs to hold them firmly in place. Female regular snap on tip of flap mates with male regular snap on pouch body. Pouch has finger cut-out in front to facilitate removal of handcuffs. Slides onto the belt and rides in vertical position. Weatherproof. Water drain hole.

3.1.43.2 Construction Materials

The holder is laminated of engineered copolymer encased by polyurethane on the outside and Buck suede on the inside. Back and flap are each laminated with 3 1/2 – 4 ounce leather and polyurethane. TRW/DOT regular snap. #207 nylon cord stitching.

3.1.43.3 Available Finishes

Plain, Basketweave, Hi-Gloss, Nylon Look, STX Tactical®.

3.1.43.4 Available Belt Loops

Standard 2 ¼" (58 mm) belt loop.

3.1.43.5 Manufacturing Process

Laminate is bonded with glue and heat and pressure formed. All edges are sanded smooth and burnished. Stitched together with #207 nylon cord.

3.1.43.6 Dimensions and Weights:

Imperial Metric

Weight:	.20 lb.	90.71 gr
Length:	5"	12.7 cm
Height:	2"	5.08 cm
Width:	4"	10.16 cm

Quality Control

ISO 9001 Societe Generale de Surveillance – ANSI RAB Registrar AQS Quality Procedure

3.1.44

Leather Belt Keeper, 3/4" Two Snaps

Item Code: 5456 or equivalent



- 3/4" wide
- Top grain leather
- Two solid brass snaps (available in 3 finishes)

3.1.45

Double magazine pouch

General Description

Double magazine pouch designed to carry two reloading magazines for pistol handguns.

3.1.45.1 Product Function

Carries two magazines in two separate holders in a stable, tactically ready configuration (Water drain holes). Magazines ride in butt up position. Flap closure devices fasten over magazines to hold them firmly in place. Cut low for excellent access to magazines, with up to 1 ½" drop. Slides on belt and rides in vertical or horizontal position. Weatherproof. A tension screw located between the two pouches allows for easy magazine retention adjustment, with 5/8" space between each pouch for easy grip. Snap version has female regular snaps on tips of flaps mate with male regular, snaps. 77HS Hidden Snap Version - Female snaps are Concealed or hidden on the inside of the tips of the flaps, no hardware is exposed on the outside of flap. For use on Sam Browne 2" (50mm), 2 ¼" (58mm) or Nylon reinforced Duty Belts.

3.1.45.2 Construction Materials

The two holders are laminated using an engineered copolymer on the inside and polyurethane on the outside. The flaps and belt loop are laminated with one layer of polyurethane laminated and stitched to 3 ½ - 4 ounce pebble-finished split leather for strength and flexibility. TRW/Dot regular snaps. #207 nylon cord stitching.
Note: STX Tactical series is manufactured with Nylon Look finish, black plastic covered snaps, and hair cell engineered copolymer magazine box.

3.1.45.3 Available Finishes

Plain, Basket weaves, Hi-Gloss, Nylon Look, STX Tactical finish.

3.1.45.4 Available Belt Loops

Standard 2 ¼" belt loop.

3.1.45.5 Dimensions and Weights:**Imperial Metric**

Weight:	.28 lbs.	127 gr
Length:	6"	15.24 cm
Height:	2"	5.08 cm
Width:	4 ½"	11.43 cm

Quality Control

ISO 9001 Societe Generale de Surveillance – ANSI RAB Registrar AQS Quality Procedure.

3.1.46 Holster**SPECIFICATION - RFL-456****~~TRIPLE RETENTION DUTY HOLSTER~~****GENERAL DESCRIPTION**

The RFL-456 is a lightweight polymer based mid-ride retention holster thermoformed to fit a specific handgun. It is lined with suede, and incorporates two patented locking mechanisms. This holster combines a high level of handgun security with durability, ease of use and training.

3.1.46.1 DETAILED DESCRIPTION

- A. The 3-layer holster body is composed of a solid polymer core material laminated to a black leather-look urethane for long lasting good looks and durability. The body of the holster incorporates a hardened steel reinforcement plate to help resist any forced removal of the weapon by an assailant. The body is lined with urethane suede that is permanently bonded to the core. The body is thermoformed to securely fit a specific handgun.
- B. The body of the RFL-456 holster is bolted in 7 places to a patented trigger guard locking mechanism. It is both very secure and easy for the wearer to operate. When the gun is inserted in the holster a ½ inch thick locking bolt automatically secures the trigger guard with no further motion required. Release of the lock is by a simple motion of the thumb as the hand tightens its grip on the gun and draws straight up.
- C. The jacket-slot belt loop is injection molded of a durable polymer and is anatomically shaped to be comfortable when worn on a duty belt. The belt loop is secured in position on a duty belt with a simple and secure device that does not mark or harm the belt.
- D. All hardware used in the assembly of this holster is stainless steel or brass.
- E. In addition to the internal locking mechanism, the 391 series holsters incorporate a rotating cover strap. This strap may be released independently of the main trigger guard lock, or will automatically release when the main lock is cycled providing almost instantaneous release of level three retention.

F. Plain finish.

**3.1.47 Safariland Duty Gear Technical Specification Package Model 306
(ASP Holder) or equal**

General Description

Flashlight carrier with flap is designed to hold mini-flashlights on 2-1/4" (58 mm) duty belts.

3.1.47.1 Product Function

Shall Carry flashlight in a stable, tactically ready configuration. Light sits with lens in upright position. Slides onto or snaps around the belt. Rides in a vertical position. Flap with snap closure covers top of light. Closed bottom. Weatherproof. Water drain hole.

3.1.47.2 Construction Materials

Shall have rounded portion of carrier is laminated with copolyester sheeting encased by an engineered material and Buc suede on the inside. The back or belt loop portion is copolyester sheeting encased again by engineered material. Stitched at all laminated edges with #207 nylon cord.

Note: STX Tactical® series is manufactured with nylon look material, and a haircell engineered copolymer mag box.

3.1.47.3 Available Finishes

Shall have Plain, Basketweave, Hi-Gloss, Nylon Look, STX Tactical®

3.1.47.4 Available Belt Loops

Standard 2 1/4" (58 mm) belt loop.

3.1.47.5 Manufacturing Process

Laminate is bonded with glue and heat and pressure formed. All edges are sanded smooth and burnished. Stitched together with #207 nylon cord.

3.1.47.6 Dimensions and Weights:

Imperial Metric

Weight:	.22 lbs.	.08 kg
Length:	6 1/8"	15.558 cm
Height:	2 1/4"	5.715 cm
Width:	1 3/4"	4.445 cm

3.1.48 ASP Expandable Baton 21 inch

Full-size authority and reliability in an easy to carry package.

Black, chrome plated steel shaft

Closed length of 7-3/4" expands to 21"

Foamed vinyl grip provides a positive gripping surface

Weighs 16.5 oz.

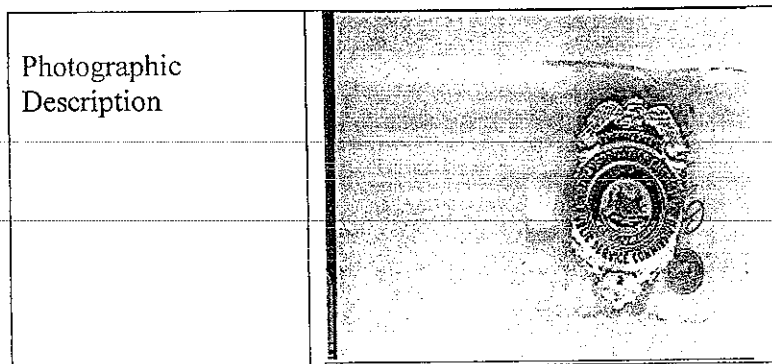
3.1.49 Badges**Standard is shell back****Incised lettering with regular enamel****Four lines of lettering****Takes a 15/16" seal****Available with safety catch, wallet clip or screw back attachment , Color Silver and Gold****3.1.49.1****Blackinton J-1 Silver Name Badge or equal to
2.5" x 1/2"****3.1.49.2****Blackinton J-1 Gold Name Badge or equal to
2.5" x 1/2"****3.1.49.3****Double American Flag Pins - Clutch Back****3.1.49.4****Blackinton Tie Tacks - WV Full color Seal - Silver & Gold or equal to
11/16" of an inch in size****3.1.49.5****Samuel Broome Black Clip on ties or equal to -
20" in length - 100% polyester - Style #9004****3.1.49.6****Blackinton Collar Pins - WVPSC - Silver & Gold or equal to
Style #10 - 5/16"**

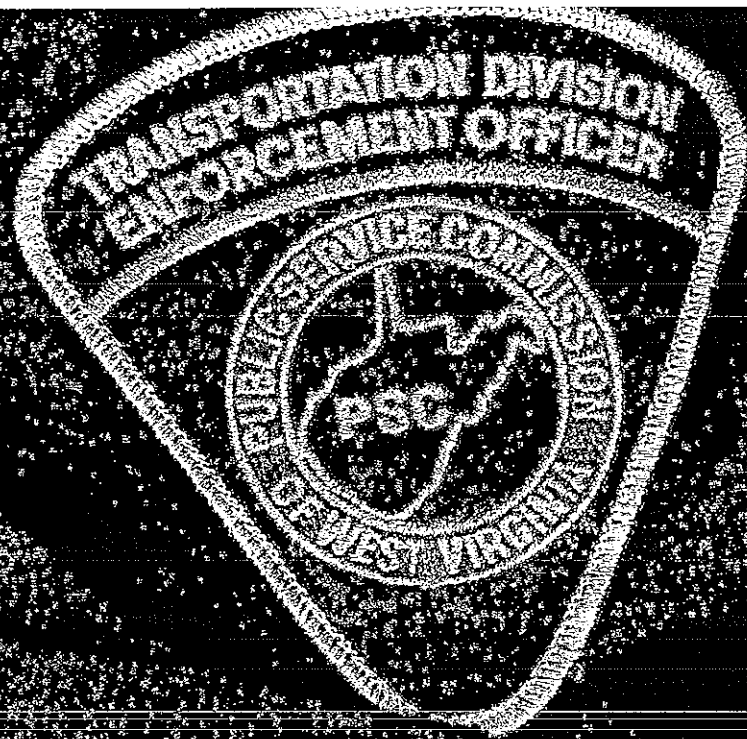

The **PRO-SID**
Uniform System
You Need

REQUEST FOR QUOTATION
RFQ PSC1010

3.2 Contract Award: The Contract is intended to provide Agencies with a purchase price on all Contract Items. The Contract shall be awarded to the Vendor that provides the Contract Items meeting the required specifications for the lowest overall total cost as shown on the Pricing Pages.

3.3 Pricing Pages: Vendor should complete the Pricing Pages by each item listed. Vendor should complete the Pricing Pages in their entirety as failure to do so may result in Vendor's bids being disqualified.

The Pricing Pages contain a list of the Contract Items and estimated purchase volume. The estimated purchase volume for each item represents the approximate volume of anticipated purchases only. No future use of the Contract or any individual item is guaranteed or implied.

Notwithstanding the foregoing, the Purchasing Division may correct errors at its discretion. Vendor should type or electronically enter the information into the Pricing Pages to prevent errors in the evaluation. The Pricing Pages were created as a Microsoft Excel document and Vendor can request an electronic copy for bid purposes by sending an email request to the following address: guy.l.nisbet@wv.gov

4. ORDERING AND PAYMENT:

4.1 Ordering: Vendor shall accept orders by regular mail, facsimile, e-mail, or any other written forms of communication. Vendor may, but is not required to, accept on-line orders through a secure internet ordering portal/website. If Vendor has the ability to accept on-line orders, it should include in its response a brief description of how Agencies may utilize the on-line ordering system. Any on-line ordering system must have the capability to restrict prices and available items to conform to the Catalog originally submitted with this RFQ. Vendor shall ensure that its on-line ordering system is properly secured prior to processing Agency orders on-line.

4.2 Payment: Vendor shall accept payment in accordance with the payment procedures of the State of West Virginia.

5. DELIVERY AND RETURN:

5.1 Delivery Time: Vendor shall deliver standard orders within 10 working days after orders are received. Vendor shall deliver emergency orders within 5 working day(s) after orders are received. Vendor shall ship all orders in accordance with the above schedule and shall not hold orders until a minimum delivery quantity is met.

5.2 Late Delivery: The Agency placing the order under this Contract must be notified in writing if orders will be delayed for any reason. Any delay in delivery that could cause harm to an Agency will be grounds for cancellation of the delayed order,

REQUEST FOR QUOTATION
RFQ PSC1010

and/or obtaining the items ordered from a third party.

Any Agency seeking to obtain items from a third party under this provision must first obtain approval of the Purchasing Division.

- 5.3 Delivery Payment/Risk of Loss:** Standard order delivery shall be F.O.B. destination to the Agency's location. Vendor shall include the cost of standard order delivery charges in its bid pricing/discount and is not permitted to charge the Agency separately for such delivery. The Agency will pay delivery charges on all emergency orders provided that Vendor invoices those delivery costs as a separate charge with the original freight bill attached to the invoice.
- 5.4 Return of Unacceptable Items:** If the Agency deems the Contract Items to be unacceptable, the Contract Items shall be returned to Vendor at Vendor's expense and with no restocking charge. Vendor shall either make arrangements for the return within five (5) days of being notified that items are unacceptable, or permit the Agency to arrange for the return and reimburse Agency for delivery expenses. ~~If the original packaging cannot be utilized for the return, Vendor will supply the Agency with appropriate return packaging upon request.~~ All returns of unacceptable items shall be F.O.B. the Agency's location. The returned product shall either be replaced, or the Agency shall receive a full credit or refund for the purchase price, at the Agency's discretion.
- 5.5 Return Due to Agency Error:** Items ordered in error by the Agency will be returned for credit within 30 days of receipt, F.O.B. Vendor's location. Vendor shall not charge a restocking fee if returned products are in a resalable condition. Items shall be deemed to be in a resalable condition if they are unused and in the original packaging. Any restocking fee for items not in a resalable condition shall be the lower of the Vendor's customary restocking fee or 5% of the total invoiced value of the returned items.

6. MISCELLANEOUS:

- 6.1 No Substitutions:** Vendor shall supply only Contract Items submitted in response to the RFQ unless a contract modification is approved in accordance with the provisions contained in this Contract.
- 6.2 Vendor Supply:** Vendor must carry sufficient inventory of the Contract Items being offered to fulfill its obligations under this Contract. By signing its bid, Vendor certifies that it can supply the Contract Items contained in its bid response.

REQUEST FOR QUOTATION
RFQ PSC1010

- 6.3 Reports:** Vendor shall provide quarterly reports and annual summaries to the Agency showing the Agency's items purchased, quantities of items purchased, and total dollar value of the items purchased. Vendor shall also provide reports, upon request, showing the items purchased during the term of this Contract, the quantity purchased for each of those items, and the total value of purchases for each of those items. Failure to supply such reports may be grounds for cancellation of this Contract.
- 6.4 Contract Manager:** During its performance of this Contract, Vendor must designate and maintain a primary contract manager responsible for overseeing Vendor's responsibilities under this Contract. The Contract manager must be available during normal business hours to address any customer service or other issues related to this Contract. Vendor should list its Contract manager and his or her contact information below.

Contract Manager: Tim Anderson
Telephone Number: 304-925-0305
Fax Number: 304-925-3648
Email Address: Tanderson@USE9SR.COM

ATTACHMENT A: UNIFORM BID SCHEDULE						
Description / Size			Unit Price	Estimated Quantity	Extended Price	
			\$	X	\$	
UNIFORM TROUSER 32282						
Short Rise - 28 - 40 Even Only			63.00	50	3150.00	
Regular Rise - 28 - 56 Even only over 38			63.00	50	3150.00	
Long Rise - 32 - 42 Even Only			63.00	50	3150.00	
WOMEN TROUSER						
Size 4 - 26			63.00	5	315.00	
LONG SLEEVE DRESS UNIFORM SHIRT						
Small - Xlarge 46w6691			35.00	50	1750.00	
2XL - 4XL			35.00	50	1750.00	
SHORT SLEEVE DRESS UNIFORM SHIRT						
Small - Xlarge 96R6691			32.00	50	1600.00	
2XL - 4XL			32.00	50	1600.00	
TACTICAL PANT (or equal)						
Waist Size - 28 - 42 74273			36.00	50	1800.00	
Waist Size - 44 - 54			43.00	50	2150.00	
TACTICAL LONG SLEEVE SHIRT (or equal)						
Small - 3XL Regular 72175			36.00	50	1800.00	
Large - 5XL Tall			39.00	50	1950.00	
TACTICAL SHORT SLEEVE SHIRT (or equal)						
Small - 3XL Regular 71175			36.00	50	1800.00	
Large - 5XL Tall			39.00	50	1950.00	
HATS 930-BK						
6 Panel			5.00	10	50.00	
PATCHES MTO						
USA GOLD FLAG			1.50	100	150.00	
SMALL PSC EMBLEM			1.50	100	150.00	
LARGE PSC EMBLEM			2.50	100	250.00	
GPS PATCH			3.00	10	30.00	
CHUCKA BOOT W/BUCKLE or equal						
B WIDTH 3-9 83			96.00	25	2400.00	
D WIDTH 3-12			96.00	25	2400.00	
E WIDTH 7-13			96.00	25	2400.00	
OXFORD SHOES or equal						
B/C WIDTH 9-13 932			85.00	15	1275.00	
D/E WIDTH 6-14			85.00	15	1275.00	
EEE WIDTH 7-13			85.00	15	1275.00	
INSULATED BOOT 42 919						
B/C WIDTH 9-13			153.00	50	7650.00	
D/E WIDTH 6-14			153.00	50	7650.00	
EEE WIDTH 7-13			153.00	50	7650.00	
CAMPAIGN STYLE HAT F-40						
3" BRIM			107.00	10	1070.00	

DUTY BELT		87-xx-x				
SIZE 38			55.00		50	2750.00
DRESS COAT		78141				
Regular - S - XXXL			280.00		50	14,000.00
Short - S-L			280.00		50	14,000.00
Long S-XXX			280.00		50	14,000.00
SHORT SLEEVE BUTTON SHIRT						
Small - Xlarge	Carhart S200		20.00		50	1,000.00
2XL - 4XL			24.00		50	1,200.00
LONG SLEEVE BUTTON SHIRT						
Small - Xlarge	Carhart S202		24.00		50	1200.00
2XL - 4XL			32.00		50	1600.00
JACKETS		San Mar J701				
Small - Xlarge			40.00		50	2,000.00
2XL - 4XL			47.00		50	2350.00
TROUSER BELT		Boston 6582				
Small - Xlarge			13.00		25	325.00
2XL - 4XL			16.00		25	400.00
DOCKER PANTS or equal		Edward's				
Waist Size - 28-42	2630		27.00		75	2025.00
Waist Size - 44-54			35.00		75	2625.00
ROCKPORT SHOES or equal						
B/C WIDTH 9-13	Rockport		66.00		15	990.00
D/E WIDTH 6-14			66.00		15	990.00
EEE WIDTH 7-13			66.00		15	990.00
REDWING BOOT or equal		Redwing 414				
B/C WIDTH 9-13			205.00		15	3075.00
D/E WIDTH 6-14			205.00		15	3075.00
EEE WIDTH 7-13			205.00		15	3075.00
MENS TAC PRO PANT or equal		74273				
Waist Size - 28-42			36.00		50	1800.00
Waist Size - 44-54			43.00		50	2150.00
MENS TDU PANT or equal		74003				
Waist Size - 28-42			35.00		50	1750.00
Waist Size - 44-54			43.00		50	2150.00
WOMEN'S TAC PRO PANT or equal						
Waist Size - 28-42 20	64360		36.00		5	180.00
Waist Size - 44-54 220			43.00		5	215.00
WOMEN'S TDU PANT or equal						
Waist Size - 28-42 20	64359		35.00		5	175.00
Waist Size - 44-54 220			43.00		5	215.00
MENS SHORT SLEEVE PRO SHIRT or equal						
Small - 3XL Regular	71175		36.00		25	900.00
Large - 5XL Tall			39.00		25	975.00
MENS LONG SLEEVE PRO SHIRT or equal						
Small - 3XL Regular	72175		36.00		25	900.00
Large - 5XL Tall			39.00		25	975.00

* Equal Product Bid

WOMENS POLO		61165				
Small - Xlarge			30.00		5	150.00
2XL - 4XL			30.00		5	150.00
WOMENS TAC PRO LS SHIRT or equal						
Small - Xlarge		62070	36.00		5	180.00
2XL - 4XL			39.00		5	195.00
MENS PARKA		48032				
Small - Xlarge			172.00		10	1720.00
2XL - 4XL			178.00		10	1780.00
WOMENS PARKA		48032				
Small - Xlarge			172.00		5	1720.00
2XL - 4XL			178.00		5	1780.00
MENS UNDER ARMOR SS TSHIRT or equal						
Small - Xlarge		1216028	18.00		20	360.00
2XL - 4XL			18.00		20	360.00
MENS UNDER ARMOR LS TSHIRT or equal						
Small - Xlarge		1216029	21.00		20	420.00
2XL - 4XL			21.00		20	420.00
MENS UNDER ARMOR LS CREW or equal						
Small - Xlarge		1216005	34.00		20	680.00
2XL - 4XL			34.00		20	680.00
WOMENS UA SS TSHIRT or equal						
Small - Xlarge		1201259	18.00		5	90.00
2XL - 4XL			18.00		5	90.00
WOMENS UA LS TSHIRT or equal						
Small - Xlarge		1209401	34.00		5	170.00
2XL - 4XL			34.00		5	170.00
WOMENS UA LONGSLEEVE CREW (or equal)						
Small - Xlarge		1212171	34.00		5	170.00
2XL - 4XL			34.00		5	170.00
MENS UA LEGGINGS or equal						
Small - Xlarge		1216006	34.00		20	680.00
2XL - 4XL			34.00		20	680.00
WOMENS UA LEGGINGS (or equal)						
Small - Xlarge		1221968	34.00		5	170.00
2XL - 4XL			34.00		5	170.00
UNDER ARMOR HOOD (or equal)						
WHITE		1223223	19.00		15	285.00
* DANNER BOOT or equal						
B/C WIDTH 9-13		22600	223.00		10	2230.00
D/E WIDTH 6-14			223.00		10	2230.00
EEE WIDTH 7-13			223.00		10	2230.00
* WOMENS DANNER BOOT or equal						
B/C WIDTH 9-13		22600-F	223.00		5	1115.00
D/E WIDTH 6-14			223.00		5	1115.00
EEE WIDTH 7-13			223.00		5	1115.00
LS FLAME RESISTANT treated SHIRT						

* Equal Product Bid

Small - Xlarge		66.00		5	330.00
2XL - 4XL		69.00		5	345.00
BLACK CLIP ON TIE - 20" 90043BK					
BLACK CLIP ON TIE - 20"		4.00		10	40.00
FLAME RESISTANT treated KHAKI PANTS					
Waist Size - 28-42	Codet	55.00		50	2750.00
Waist Size - 44-54	Tx14314S9	66.00		50	3300.00
FLAME RESISTANT treated DENIM PANTS					
Waist Size - 28-42	Codet	55.00		50	2750.00
Waist Size - 44-54	Tx9101N14	66.00		50	3300.00
FLAME RESISTANT treated COVERALL					
Waist Size - 28-42	Codet	78.00		10	780.00
Waist Size - 44-54	Tx1331TST	93.00		10	930.00
EQUIPMENT					
HANDCUFFS	190H	31.00		10	310.00
LEATHER BELT KEEPER	Boster	4.95		10	49.50
DOUBLE MAGAZINE POUCH	7HS	33.00		10	330.00
HOLSTER	391 - G+G	115.00		10	1150.00
ASP HOLDER	ASP	33.00		10	330.00
ASP EXPANDABLE BATON	F-21	80.00		10	800.00
BADGES					
Silver Name Badge	B-38	48.00		10	480.00
Gold Name Badge	J-1	8.00		10	80.00
American Flag Pin	MTO	8.00		10	80.00
Color WVPSC Pin	MTO	41.00		10	410.00
TIE TACKS - WV Full Color Seal	MTO	15.00		25	375.00
TOTAL BID					190,039.50

CERTIFICATION AND SIGNATURE PAGE

By signing below, I certify that I have reviewed this Solicitation in its entirety; understand the requirements, terms and conditions, and other information contained herein; that I am submitting this bid or proposal for review and consideration; that I am authorized by the bidder to execute this bid or any documents related thereto on bidder's behalf; that I am authorized to bind the bidder in a contractual relationship; and that to the best of my knowledge, the bidder has properly registered with any State agency that may require registration.

WV Uniforms
(Company)

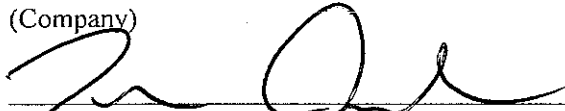
(Authorized Signature)

Tim Anderson / GM
(Representative Name, Title)

304-925-0305 304-925-3648
(Phone Number) (Fax Number)

03-04-2013
(Date)

State of West Virginia

VENDOR PREFERENCE CERTIFICATE

Certification and application* is hereby made for Preference in accordance with **West Virginia Code**, §5A-3-37. (Does not apply to construction contracts). **West Virginia Code**, §5A-3-37, provides an opportunity for qualifying vendors to request (at the time of bid) preference for their residency status. Such preference is an evaluation method only and will be applied only to the cost bid in accordance with the **West Virginia Code**. This certificate for application is to be used to request such preference. The Purchasing Division will make the determination of the Resident Vendor Preference, if applicable.

1. **Application is made for 2.5% resident vendor preference for the reason checked:**
 Bidder is an individual resident vendor and has resided continuously in West Virginia for four (4) years immediately preceding the date of this certification; **or**,
 Bidder is a partnership, association or corporation resident vendor and has maintained its headquarters or principal place of business continuously in West Virginia for four (4) years immediately preceding the date of this certification; or 80% of the ownership interest of Bidder is held by another individual, partnership, association or corporation resident vendor who has maintained its headquarters or principal place of business continuously in West Virginia for four (4) years immediately preceding the date of this certification; **or**,
 Bidder is a nonresident vendor which has an affiliate or subsidiary which employs a minimum of one hundred state residents and which has maintained its headquarters or principal place of business within West Virginia continuously for the four (4) years immediately preceding the date of this certification; **or**,
2. **Application is made for 2.5% resident vendor preference for the reason checked:**
 Bidder is a resident vendor who certifies that, during the life of the contract, on average at least 75% of the employees working on the project being bid are residents of West Virginia who have resided in the state continuously for the two years immediately preceding submission of this bid; **or**,
3. **Application is made for 2.5% resident vendor preference for the reason checked:**
 Bidder is a nonresident vendor employing a minimum of one hundred state residents or is a nonresident vendor with an affiliate or subsidiary which maintains its headquarters or principal place of business within West Virginia employing a minimum of one hundred state residents who certifies that, during the life of the contract, on average at least 75% of the employees or Bidder's affiliate's or subsidiary's employees are residents of West Virginia who have resided in the state continuously for the two years immediately preceding submission of this bid; **or**,
4. **Application is made for 5% resident vendor preference for the reason checked:**
 Bidder meets either the requirement of both subdivisions (1) and (2) or subdivision (1) and (3) as stated above; **or**,
5. **Application is made for 3.5% resident vendor preference who is a veteran for the reason checked:**
 Bidder is an individual resident vendor who is a veteran of the United States armed forces, the reserves or the National Guard and has resided in West Virginia continuously for the four years immediately preceding the date on which the bid is submitted; **or**,
6. **Application is made for 3.5% resident vendor preference who is a veteran for the reason checked:**
 Bidder is a resident vendor who is a veteran of the United States armed forces, the reserves or the National Guard, if, for purposes of producing or distributing the commodities or completing the project which is the subject of the vendor's bid and continuously over the entire term of the project, on average at least seventy-five percent of the vendor's employees are residents of West Virginia who have resided in the state continuously for the two immediately preceding years.
7. **Application is made for preference as a non-resident small, women- and minority-owned business, in accordance with West Virginia Code §5A-3-59 and West Virginia Code of State Rules.**
 Bidder has been or expects to be approved prior to contract award by the Purchasing Division as a certified small, women- and minority-owned business.

Bidder understands if the Secretary of Revenue determines that a Bidder receiving preference has failed to continue to meet the requirements for such preference, the Secretary may order the Director of Purchasing to: (a) reject the bid; or (b) assess a penalty against such Bidder in an amount not to exceed 5% of the bid amount and that such penalty will be paid to the contracting agency or deducted from any unpaid balance on the contract or purchase order.

By submission of this certificate, Bidder agrees to disclose any reasonably requested information to the Purchasing Division and authorizes the Department of Revenue to disclose to the Director of Purchasing appropriate information verifying that Bidder has paid the required business taxes, provided that such information does not contain the amounts of taxes paid nor any other information deemed by the Tax Commissioner to be confidential.

Under penalty of law for false swearing (West Virginia Code, §61-5-3), Bidder hereby certifies that this certificate is true and accurate in all respects; and that if a contract is issued to Bidder and if anything contained within this certificate changes during the term of the contract, Bidder will notify the Purchasing Division in writing immediately.

Bidder: wv uniforms

Signed: 

Date: 03/04/2013

Title: GM

RFQ No. PSC 1010

STATE OF WEST VIRGINIA
Purchasing Division

PURCHASING AFFIDAVIT

MANDATE: Under W. Va. Code §5A-3-10a, no contract or renewal of any contract may be awarded by the state or any of its political subdivisions to any vendor or prospective vendor when the vendor or prospective vendor or a related party to the vendor or prospective vendor is a debtor and: (1) the debt owed is an amount greater than one thousand dollars in the aggregate; or (2) the debtor is in employer default.

EXCEPTION: The prohibition listed above does not apply where a vendor has contested any tax administered pursuant to chapter eleven of the W. Va. Code, workers' compensation premium, permit fee or environmental fee or assessment and the matter has not become final or where the vendor has entered into a payment plan or agreement and the vendor is not in default of any of the provisions of such plan or agreement.

DEFINITIONS:

"Debt" means any assessment, premium, penalty, fine, tax or other amount of money owed to the state or any of its political subdivisions because of a judgment, fine, permit violation, license assessment, defaulted workers' compensation premium, penalty or other assessment presently delinquent or due and required to be paid to the state or any of its political subdivisions, including any interest or additional penalties accrued thereon.

"Employer default" means having an outstanding balance or liability to the old fund or to the uninsured employers' fund or being in policy default, as defined in W. Va. Code § 23-2c-2, failure to maintain mandatory workers' compensation coverage, or failure to fully meet its obligations as a workers' compensation self-insured employer. An employer is not in employer default if it has entered into a repayment agreement with the Insurance Commissioner and remains in compliance with the obligations under the repayment agreement.

"Related party" means a party, whether an individual, corporation, partnership, association, limited liability company or any other form or business association or other entity whatsoever, related to any vendor by blood, marriage, ownership or contract through which the party has a relationship of ownership or other interest with the vendor so that the party will actually or by effect receive or control a portion of the benefit, profit or other consideration from performance of a vendor contract with the party receiving an amount that meets or exceeds five percent of the total contract amount.

AFFIRMATION: By signing this form, the vendor's authorized signer affirms and acknowledges under penalty of law for false swearing (W. Va. Code §61-5-3) that neither vendor nor any related party owe a debt as defined above and that neither vendor nor any related party are in employer default as defined above, unless the debt or employer default is permitted under the exception above.

WITNESS THE FOLLOWING SIGNATURE:

Vendor's Name: WV Uniforms
Authorized Signature: [Signature] Date: 03/05/2013

State of West Virginia
County of KANAWHA, to-wit:

Taken, subscribed, and sworn to before me this 5 day of March, 2013.
My Commission expires JANUARY 24, 2017.

AFFIX SEAL HERE

NOTARY PUBLIC

[Signature]

Purchasing Affidavit (Revised 07/01/2012)

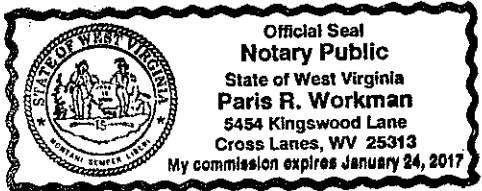

ADDENDUM ACKNOWLEDGEMENT FORM

SOLICITATION NO.: PSC1010

Instructions: Please acknowledge receipt of all addenda issued with this solicitation by completing this addendum acknowledgment form. Check the box next to each addendum received and sign below. Failure to acknowledge addenda may result in bid disqualification.

Acknowledgment: I hereby acknowledge receipt of the following addenda and have made the necessary revisions to my proposal, plans and/or specification, etc.

Addendum Numbers Received:

(Check the box next to each addendum received)

- | | |
|---|--|
| <input type="checkbox"/> Addendum No. 1 | <input type="checkbox"/> Addendum No. 6 |
| <input type="checkbox"/> Addendum No. 2 | <input type="checkbox"/> Addendum No. 7 |
| <input type="checkbox"/> Addendum No. 3 | <input type="checkbox"/> Addendum No. 8 |
| <input type="checkbox"/> Addendum No. 4 | <input type="checkbox"/> Addendum No. 9 |
| <input type="checkbox"/> Addendum No. 5 | <input type="checkbox"/> Addendum No. 10 |

I understand that failure to confirm the receipt of addenda may be cause for rejection of this bid. I further understand that any verbal representation made or assumed to be made during any oral discussion held between Vendor's representatives and any state personnel is not binding. Only the information issued in writing and added to the specifications by an official addendum is binding.

Company

Authorized Signature

Date

NOTE: This addendum acknowledgment should be submitted with the bid to expedite document processing.

WEST VIRGINIA

UNIFORMS

A Fechheimer Uniform Center

03-5-2013

Public Service Commission of West Virginia
201 Brooke Street
Charleston, WV 25301

Reference: PSC1010

Dear Guy Nisbet:

Thank you for allowing West Virginia Uniforms the opportunity to bid on PSC1010.

Some items cannot be delivered in 10 days they are made to order. We will work with the Public Service Commission on the items that will take longer than 10 days.

Regards,

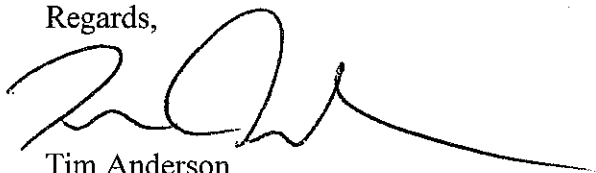

Tim Anderson
WV Uniforms
GM