



**State of West Virginia  
Department of Administration  
Purchasing Division**

**NOTICE**

Due to the size of this bid, it was impractical to scan every page for online viewing. We have made an attempt to scan and publish all pertinent bid information. However, it is important to note that some pages were necessarily omitted.

If you would like to review the bid in its entirety, please contact the buyer. Thank you.

\*\*\*

06/10/2013

West Virginia Department of Education  
Department of Administration, Purchasing Division  
P.O. Box 50130  
Charleston, WV 25305-0130

RE: Letter of Transmittal

I want to personally thank you for this opportunity to respond to the West Virginia Department of Education's RFP for a Internet Filtering and Reporting Solution RFP # EDD392953. We at iBoss Security appreciate our EDU community and value all of your thoughts and opinions especially when it comes to products like Internet Content Filtering.

iBoss Enterprise SWG provides a comprehensive solution to not only control HTTP/S and application traffic but also insure network critical applications are available during peak hours while reducing recreational traffic. iBoss Enterprise SWG's ability to filter by URL vs. Domain allows organizations to implement more flexible Internet Use Policies. Examples include the ability to allow access on an organization's Facebook page while restricting general access to facebook.com. The ability to restrict posting on social networking sites insures organizations are protected from data loss and compromise. Designed for H.A. networks, iBoss Enterprise Filters provide throughput and scaling options for large enterprises. Clustering, load balancing and 802.3ad integration insure control without compromise. With each appliance capable of over 6+ million concurrent TCP/IP connections, iBoss Filters are designed for the most demanding networks.

Enclosed is our proposal for the Internet Filtering and Reporting Solution from Phantom Technologies Inc. We have read all sections and agree to all terms and conditions outlined therein. Included in this package is a CD which contains all documents submitted in the proposal. Please look over this content and if you have any comments or questions, our iBoss team would love to hear from you.

Again we appreciate this opportunity and we hope to work with the West Virginia Department of Education on this very important project.

Sincerely,



Eddie Kim  
Authorized Respondent  
iBoss Security, Division of  
Phantom Technologies, Inc (CA Corp)  
877-742-6832 x 7109  
858-225-6158 (Fax)  
[Eddie.kim@iboss.com](mailto:Eddie.kim@iboss.com)  
Spin: 143035306

06/12/13 09:10:28 AM  
West Virginia Purchasing Division



State of West Virginia  
 Department of Administration  
 Purchasing Division  
 2019 Washington Street East  
 Post Office Box 50130  
 Charleston, WV 25305-0130

**Solicitation**

NUMBER  
 EDD392953

PAGE  
 1

ADDRESS CORRESPONDENCE TO ATTENTION OF:  
 CONNIE OSWALD  
 304-558-2157

V  
E  
N  
D  
O  
R

iBOSS WEB SECURITY  
 A DIVISION OF PHANTOM TECHNOLOGY  
 9950 SUMMERS RIDGE ROAD, #160  
 SAN DIEGO, CA 92121

S  
H  
I  
P  
T  
O

DEPARTMENT OF EDUCATION  
 BUILDING 6  
 1900 KANAWHA BOULEVARD, EAST  
 CHARLESTON, WV  
 25305-0330

DATE PRINTED  
 05/16/2013

BID OPENING DATE: 06/13/2013 BID OPENING TIME 1:30PM

LINE	QUANTITY	UOP	CAT NO	ITEM NUMBER	UNIT PRICE	AMOUNT
001	1	JB		920-45		
THE STATE OF WEST VIRGINIA AND ITS AGENCY THE WEST VIRGINIA DEPARTMENT OF EDUCATION REQUEST A QUOTE TO PROVIDE AN INTERNET FILTERING AND REPORTING SOLUTION THAT CONSISTS OF SOFTWARE, LICENSING, SOFTWARE UPGRADES/UPDATES, DATABASE UPDATES AND TECHNICAL SUPPORT PER THE SPECIFICATIONS AND INSTRUCTIONS TO BIDDERS ATTACHED.  BID OPENING: JUNE 13, 2013 AT 1:30 PM  INTERNET FILTERING & REPORTING SOLUTION THAT  CONSISTS OF SOFTWARE, LICENSING, SOFTWARE UPGRADES/UPDATES, DATABASE UPDATES AND TECHNICAL SUPPORT.  ***** THIS IS THE END OF RFQ EDD392953 ***** TOTAL:						

SIGNATURE  TELEPHONE 877-742-6832 x7109 DATE 6/10/13  
 TITLE Operations Manager FEIN 80-0700728 ADDRESS CHANGES TO BE NOTED ABOVE

WHEN RESPONDING TO SOLICITATION, INSERT NAME AND ADDRESS IN SPACE ABOVE LABELED 'VENDOR'

REQUEST FOR QUOTATION  
 EDD392953 Internet Filtering and Reporting Solution

Pricing Page

Exhibit "A"

Item	Vendor Description	Quantity	Unit Cost	Total Cost
Annual software cost for Filtering Servers.* <i>Vendor to specify quantity</i>	Included with appliance	8	0.00	0.00
Annual software cost for Reporting Servers.* <i>Vendor to specify quantity</i>	Included with appliance	1	0.00	0.00
Annual License for filtering of client computers on K-12 network.	Licensing for 200,000 Computers, 280,000 Users for 1 year	280,000	\$0.60	\$120,000.00
Annual License for mobile computers. (see note 1 below.)	Licensing for 10,000 Mobile Clients	10,000	\$0.60	\$6,000.00
Technical support and upgrades/updates for filtering solution	Included at No Cost	1 year	0.00	0.00
One Day onsite training, 6 hours. Charleston WV (see note 2 below)	Tier 3 iBoss Engineer	1 day	\$1500.00	\$1500.00
Onsite installation, Charleston and Morgantown, WV (see note 2 below)	Tier 3 iBoss Engineer	4 days	\$1500.00	\$6000.00
Filtering Servers (if required)* <i>Vendor is to specify quantity</i>	IWF-14500-AX Enterprise SWG Filter w/10G Fiber Interface	8	\$6995.00	\$55,960.00
Reporting Servers (if required)* <i>Vendor is to specify quantity</i>	IWR-6900 RAID Reporter Internet Activity Logger/ Archiver	1	\$6995.00	\$6995.00
Other Hardware (if required)* <i>Vendor is to specify quantity</i>	Niagra 2801-SR Load Balancer	2	\$23,995.00	\$47,990.00
Hourly rate for custom system modifications	Included	20 hours	0.00	0.00
<b>Grand Total</b>				\$244,445.00

REQUEST FOR QUOTATION  
EDD392953 Internet Filtering and Reporting Solution

**Note 1:** A mobile computer requires special client software that will force the computer to be filtered even when it is disconnected from the K-12 network and connected to any other network which provides Internet access. If there is no price difference for mobile computers, enter the same unit cost as for computers on the K-12 network.

**Note 2:** Costs for training and installation, configuration and testing **must** be inclusive of all incidental costs. Travel expenses, training materials and other reimbursable expenses will not be paid separately. The distance between Charleston and Morgantown WV is approximately 180 miles.

**Item Pricing:**

This worksheet is for vendors to identify items, quantities and provide prices. The vendor should indicate "No Cost" or "N/A" in the appropriate cells or blanks of the cost worksheet for which there are no separate or applicable costs. Any cost area that is left blank will be assumed to be "No Cost." The vendor may add notes to explain or clarify the bid.

\* Vendor is encouraged to provide unit pricing for each of these items. However, it shall be the responsibility of the vendor to determine sufficient quantities needed for the scope of work outlined in the RFQ. For example, the quantity of servers needed to provide coverage for the WVDE's network may be set at one for vendor A, but be determined to be 5 by vendor B, due to design efficiencies.

Signature: \_\_\_\_\_

Date: 6/10/2013

Company Name: \_\_\_\_\_

Phantom Technologies Inc

Address: \_\_\_\_\_

9950 Summers Ridge Rd. Ste. 160 San Diego, CA. 92121

Phone: \_\_\_\_\_

(877) 742-6832 Ext. 7109

Fax: \_\_\_\_\_

(858) 225-6158

Email: \_\_\_\_\_

Eddie.Kim@iboss.com

# Attachment A

## West Virginia Department of Education K-12 State Network

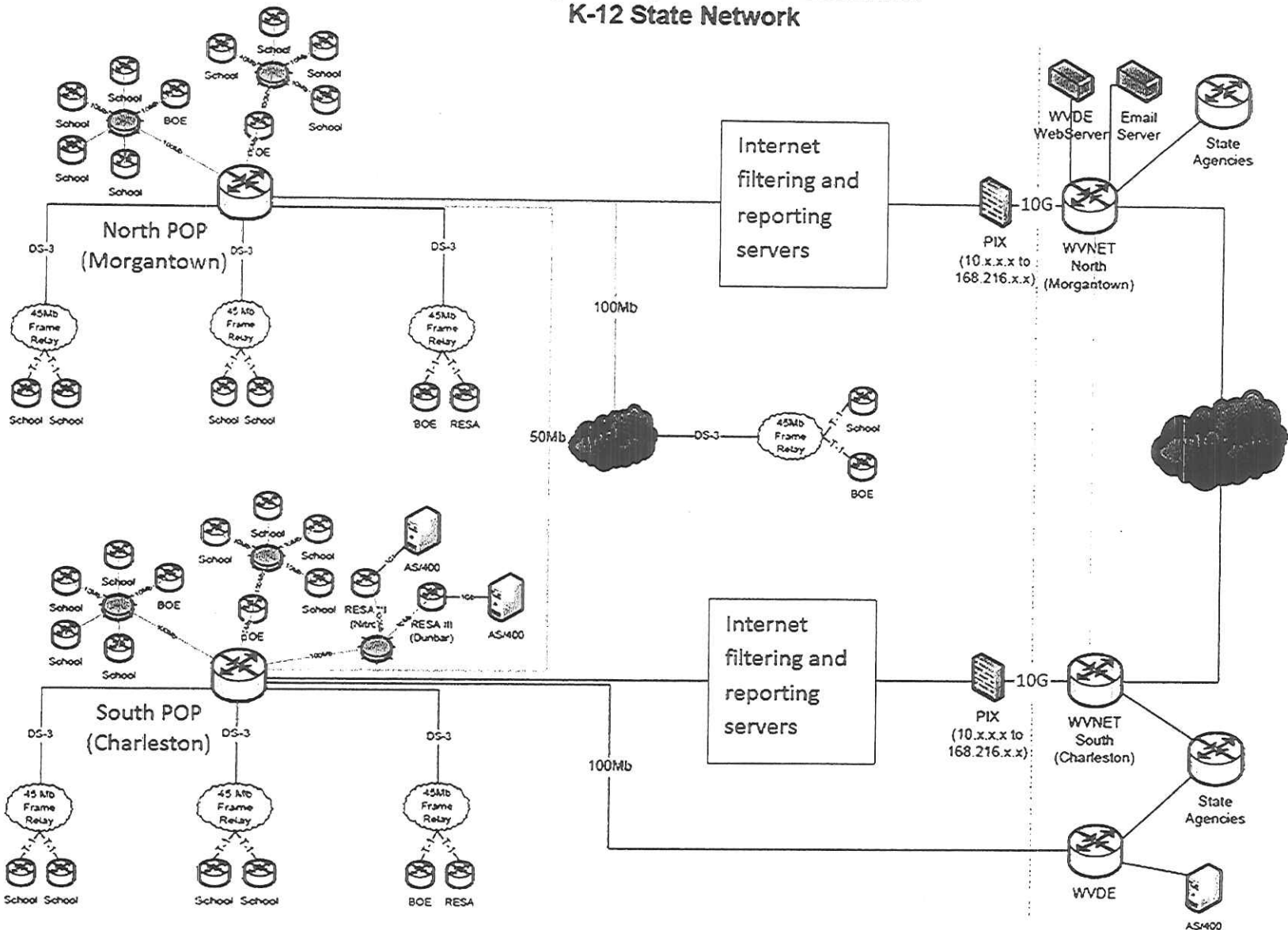

**AGREEMENT ADDENDUM FOR SOFTWARE**

In the event of conflict between this addendum and the agreement, this addendum shall control:

1. **DISPUTES** - Any references in the agreement to arbitration or to the jurisdiction of any court are hereby deleted. Disputes arising out of the agreement shall be presented to the West Virginia Court of Claims.
2. **HOLD HARMLESS** - Any provision requiring the Agency to indemnify or hold harmless any party is hereby deleted in its entirety.
3. **GOVERNING LAW** - The agreement shall be governed by the laws of the State of West Virginia. This provision replaces any references to any other State's governing law.
4. **TAXES** - Provisions in the agreement requiring the Agency to pay taxes are deleted. As a State entity, the Agency is exempt from Federal, State, and local taxes and will not pay taxes for any Vendor including individuals, nor will the Agency file any tax returns or reports on behalf of Vendor or any other party.
5. **PAYMENT** - Any references to prepayment are deleted. Fees for software licenses, subscriptions, or maintenance are payable annually in advance. Payment for services will be in arrears.
6. **INTEREST** - Any provision for interest or charges on late payments is deleted. The Agency has no statutory authority to pay interest or late fees.
7. **NO WAIVER** - Any language in the agreement requiring the Agency to waive any rights, claims or defenses is hereby deleted.
8. **FISCAL YEAR FUNDING** - Service performed under the agreement may be continued in succeeding fiscal years for the term of the agreement, contingent upon funds being appropriated by the Legislature or otherwise being available for this service. In the event funds are not appropriated or otherwise available for this service, the agreement shall terminate without penalty on June 30. After that date, the agreement becomes of no effect and is null and void. However, the Agency agrees to use its best efforts to have the amounts contemplated under the agreement included in its budget. Non-appropriation or non-funding shall not be considered an event of default.
9. **STATUTE OF LIMITATION** - Any clauses limiting the time in which the Agency may bring suit against the Vendor, lessor, individual, or any other party are deleted.
10. **SIMILAR SERVICES** - Any provisions limiting the Agency's right to obtain similar services or equipment in the event of default or non-funding during the term of the agreement are hereby deleted.
11. **FEES OR COSTS** - The Agency recognizes an obligation to pay attorney's fees or costs only when assessed by a court of competent jurisdiction. Any other provision is invalid and considered null and void.
12. **ASSIGNMENT** - Notwithstanding any clause to the contrary, the Agency reserves the right to assign the agreement to another State of West Virginia agency, board or commission upon thirty (30) days written notice to the Vendor and Vendor shall obtain the written consent of Agency prior to assigning the agreement.
13. **LIMITATION OF LIABILITY** - The Agency, as a State entity, cannot agree to assume the potential liability of a Vendor. Accordingly, any provision in the agreement limiting the Vendor's liability for direct damages is hereby deleted. Vendor's liability under the agreement shall not exceed three times the total value of the agreement. Limitations on special, incidental or consequential damages are acceptable. In addition, any limitation is null and void to the extent that it precludes any action for injury to persons or for damages to personal property.
14. **RIGHT TO TERMINATE** - Agency shall have the right to terminate the agreement upon thirty (30) days written notice to Vendor. Agency agrees to pay Vendor for services rendered or goods received prior to the effective date of termination. In such event, Agency will not be entitled to a refund of any software license, subscription or maintenance fees paid.
15. **TERMINATION CHARGES** - Any provision requiring the Agency to pay a fixed amount or liquidated damages upon termination of the agreement is hereby deleted. The Agency may only agree to reimburse a Vendor for actual costs incurred or losses sustained during the current fiscal year due to wrongful termination by the Agency prior to the end of any current agreement term.
16. **RENEWAL** - Any reference to automatic renewal is deleted. The agreement may be renewed only upon mutual written agreement of the parties.
17. **INSURANCE** - Any provision requiring the Agency to purchase insurance for Vendor's property is deleted. The State of West Virginia is insured through the Board of Risk and Insurance Management, and will provide a certificate of property insurance upon request.
18. **RIGHT TO NOTICE** - Any provision for repossession of equipment without notice is hereby deleted. However, the Agency does recognize a right of repossession with notice.
19. **ACCELERATION** - Any reference to acceleration of payments in the event of default or non-funding is hereby deleted.
20. **CONFIDENTIALITY** - Any provision regarding confidentiality of the terms and conditions of the agreement is hereby deleted. State contracts are public records under the West Virginia Freedom of Information Act.
21. **AMENDMENTS** - All amendments, modifications, alterations or changes to the agreement shall be in writing and signed by both parties. No amendment, modification, alteration or change may be made to this addendum without the express written approval of the Purchasing Division and the Attorney General.

ACCEPTED BY:

**STATE OF WEST VIRGINIA**

Spending Unit: \_\_\_\_\_

Signed: \_\_\_\_\_

Title: \_\_\_\_\_

Date: \_\_\_\_\_

**VENDOR**

Company Name: Phantom Technologies Inc.

Signed: [Signature]

Title: Operations Manager

Date: 6/10/2013

Attachment  
PO# EDD392953

This agreement constitutes the entire agreement between the parties, and there are no other terms and conditions applicable to the licenses granted hereunder.

Agreed



Signature

6/10/2013

Date

\_\_\_\_\_  
Signature Date

Operations Manager

Title

\_\_\_\_\_  
Title

Phantom Technologies, Inc.

Company Name

\_\_\_\_\_  
Agency/Division



Not Applicable

State of West Virginia

VENDOR PREFERENCE CERTIFICATE

Certification and application\* is hereby made for Preference in accordance with West Virginia Code, §5A-3-37. (Does not apply to construction contracts). West Virginia Code, §5A-3-37, provides an opportunity for qualifying vendors to request (at the time of bid) preference for their residency status. Such preference is an evaluation method only and will be applied only to the cost bid in accordance with the West Virginia Code. This certificate for application is to be used to request such preference. The Purchasing Division will make the determination of the Resident Vendor Preference, if applicable.

- 1. Application is made for 2.5% resident vendor preference for the reason checked: Bidder is an individual resident vendor and has resided continuously in West Virginia for four (4) years immediately preceding the date of this certification; or, Bidder is a partnership, association or corporation resident vendor and has maintained its headquarters or principal place of business continuously in West Virginia for four (4) years immediately preceding the date of this certification; or 80% of the ownership interest of Bidder is held by another individual, partnership, association or corporation resident vendor who has maintained its headquarters or principal place of business continuously in West Virginia for four (4) years immediately preceding the date of this certification; or, Bidder is a nonresident vendor which has an affiliate or subsidiary which employs a minimum of one hundred state residents and which has maintained its headquarters or principal place of business within West Virginia continuously for the four (4) years immediately preceding the date of this certification; or,
2. Application is made for 2.5% resident vendor preference for the reason checked: Bidder is a resident vendor who certifies that, during the life of the contract, on average at least 75% of the employees working on the project being bid are residents of West Virginia who have resided in the state continuously for the two years immediately preceding submission of this bid; or,
3. Application is made for 2.5% resident vendor preference for the reason checked: Bidder is a nonresident vendor employing a minimum of one hundred state residents or is a nonresident vendor with an affiliate or subsidiary which maintains its headquarters or principal place of business within West Virginia employing a minimum of one hundred state residents who certifies that, during the life of the contract, on average at least 75% of the employees or Bidder's affiliate's or subsidiary's employees are residents of West Virginia who have resided in the state continuously for the two years immediately preceding submission of this bid; or,
4. Application is made for 5% resident vendor preference for the reason checked: Bidder meets either the requirement of both subdivisions (1) and (2) or subdivision (1) and (3) as stated above; or,
5. Application is made for 3.5% resident vendor preference who is a veteran for the reason checked: Bidder is an individual resident vendor who is a veteran of the United States armed forces, the reserves or the National Guard and has resided in West Virginia continuously for the four years immediately preceding the date on which the bid is submitted; or,
6. Application is made for 3.5% resident vendor preference who is a veteran for the reason checked: Bidder is a resident vendor who is a veteran of the United States armed forces, the reserves or the National Guard, if, for purposes of producing or distributing the commodities or completing the project which is the subject of the vendor's bid and continuously over the entire term of the project, on average at least seventy-five percent of the vendor's employees are residents of West Virginia who have resided in the state continuously for the two immediately preceding years.
7. Application is made for preference as a non-resident small, women- and minority-owned business, in accordance with West Virginia Code §5A-3-59 and West Virginia Code of State Rules. Bidder has been or expects to be approved prior to contract award by the Purchasing Division as a certified small, women- and minority-owned business.

Bidder understands if the Secretary of Revenue determines that a Bidder receiving preference has failed to continue to meet the requirements for such preference, the Secretary may order the Director of Purchasing to: (a) reject the bid; or (b) assess a penalty against such Bidder in an amount not to exceed 5% of the bid amount and that such penalty will be paid to the contracting agency or deducted from any unpaid balance on the contract or purchase order.

By submission of this certificate, Bidder agrees to disclose any reasonably requested information to the Purchasing Division and authorizes the Department of Revenue to disclose to the Director of Purchasing appropriate information verifying that Bidder has paid the required business taxes, provided that such information does not contain the amounts of taxes paid nor any other information deemed by the Tax Commissioner to be confidential.

Under penalty of law for false swearing (West Virginia Code, §61-5-3), Bidder hereby certifies that this certificate is true and accurate in all respects; and that if a contract is issued to Bidder and if anything contained within this certificate changes during the term of the contract, Bidder will notify the Purchasing Division in writing immediately.

Bidder: \_\_\_\_\_

Signed: \_\_\_\_\_

Date: \_\_\_\_\_

Title: \_\_\_\_\_

RFQ No. EDD392953

STATE OF WEST VIRGINIA  
Purchasing Division

**PURCHASING AFFIDAVIT**

**MANDATE:** Under W. Va. Code §5A-3-10a, no contract or renewal of any contract may be awarded by the state or any of its political subdivisions to any vendor or prospective vendor when the vendor or prospective vendor or a related party to the vendor or prospective vendor is a debtor and: (1) the debt owed is an amount greater than one thousand dollars in the aggregate; or (2) the debtor is in employer default.

**EXCEPTION:** The prohibition listed above does not apply where a vendor has contested any tax administered pursuant to chapter eleven of the W. Va. Code, workers' compensation premium, permit fee or environmental fee or assessment and the matter has not become final or where the vendor has entered into a payment plan or agreement and the vendor is not in default of any of the provisions of such plan or agreement.

**DEFINITIONS:**

**"Debt"** means any assessment, premium, penalty, fine, tax or other amount of money owed to the state or any of its political subdivisions because of a judgment, fine, permit violation, license assessment, defaulted workers' compensation premium, penalty or other assessment presently delinquent or due and required to be paid to the state or any of its political subdivisions, including any interest or additional penalties accrued thereon.

**"Employer default"** means having an outstanding balance or liability to the old fund or to the uninsured employers' fund or being in policy default, as defined in W. Va. Code § 23-2c-2, failure to maintain mandatory workers' compensation coverage, or failure to fully meet its obligations as a workers' compensation self-insured employer. An employer is not in employer default if it has entered into a repayment agreement with the Insurance Commissioner and remains in compliance with the obligations under the repayment agreement.

**"Related party"** means a party, whether an individual, corporation, partnership, association, limited liability company or any other form or business association or other entity whatsoever, related to any vendor by blood, marriage, ownership or contract through which the party has a relationship of ownership or other interest with the vendor so that the party will actually or by effect receive or control a portion of the benefit, profit or other consideration from performance of a vendor contract with the party receiving an amount that meets or exceeds five percent of the total contract amount.

**AFFIRMATION:** By signing this form, the vendor's authorized signer affirms and acknowledges under penalty of law for false swearing (W. Va. Code §61-5-3) that neither vendor nor any related party owe a debt as defined above and that neither vendor nor any related party are in employer default as defined above, unless the debt or employer default is permitted under the exception above.

**WITNESS THE FOLLOWING SIGNATURE:**

Vendor's Name: Phantom Technologies, Inc

Authorized Signature: [Signature] Date: 6/11/13

State of \_\_\_\_\_

SEE ATTACHED FORM FOR  
NOTARY CERTIFICATE

County of \_\_\_\_\_, to-wit:

Taken, subscribed, and sworn to before me this \_\_\_\_ day of \_\_\_\_\_, 20\_\_.

My Commission expires \_\_\_\_\_, 20\_\_.

AFFIX SEAL HERE

NOTARY PUBLIC \_\_\_\_\_

JURAT

State of California  
County of San Diego } ss

Subscribed and sworn to (or affirmed) before me on this 11 day of June,  
2013, By Eddie Sok Kim, proved to me on  
the basis of satisfactory evidence to be the person(s) who appeared before me.

Signature Alejandro De Anda



(Notary Seal)

OPTIONAL

Title or Type of Document: Purchasing Affidavit

Document Date: \_\_\_\_\_ Number of Pages \_\_\_\_\_

Signer(s) other than named above: \_\_\_\_\_

CERTIFICATION AND SIGNATURE PAGE

By signing below, I certify that I have reviewed this Solicitation in its entirety; understand the requirements, terms and conditions, and other information contained herein; that I am submitting this bid or proposal for review and consideration; that I am authorized by the bidder to execute this bid or any documents related thereto on bidder's behalf; that I am authorized to bind the bidder in a contractual relationship; and that to the best of my knowledge, the bidder has properly registered with any State agency that may require registration.

Phantom Technologies Inc.  
(Company)

  
(Authorized Signature)

Eddie Kim, Operations Manager.  
(Representative Name, Title)

(877) 742-6832 ext. 7109      (858) 225-6158  
(Phone Number)                      (Fax Number)

6/10/2013  
(Date)

**ADDENDUM ACKNOWLEDGEMENT FORM**  
**SOLICITATION NO.:** EDD392953

**Instructions:** Please acknowledge receipt of all addenda issued with this solicitation by completing this addendum acknowledgment form. Check the box next to each addendum received and sign below. Failure to acknowledge addenda may result in bid disqualification.

**Acknowledgment:** I hereby acknowledge receipt of the following addenda and have made the necessary revisions to my proposal, plans and/or specification, etc.

**Addendum Numbers Received:**

(Check the box next to each addendum received)

- |  |  |
|--|--|
| <input checked="" type="checkbox"/> Addendum No. 1 | <input type="checkbox"/> Addendum No. 6  |
| <input type="checkbox"/> Addendum No. 2            | <input type="checkbox"/> Addendum No. 7  |
| <input type="checkbox"/> Addendum No. 3            | <input type="checkbox"/> Addendum No. 8  |
| <input type="checkbox"/> Addendum No. 4            | <input type="checkbox"/> Addendum No. 9  |
| <input type="checkbox"/> Addendum No. 5            | <input type="checkbox"/> Addendum No. 10 |

I understand that failure to confirm the receipt of addenda may be cause for rejection of this bid. I further understand that any verbal representation made or assumed to be made during any oral discussion held between Vendor's representatives and any state personnel is not binding. Only the information issued in writing and added to the specifications by an official addendum is binding.

Phantom Technologies Inc.

Company



Authorized Signature

6/10/2013

Date

NOTE: This addendum acknowledgment should be submitted with the bid to expedite document processing.

REQUEST FOR QUOTATION  
 EDD392953 Internet Filtering and Reporting Solution

Pricing Page      Exhibit "A"

Item	Vendor Description	Quantity	Unit Cost	Total Cost
Annual software cost for Filtering Servers.* <i>Vendor to specify quantity</i>	Included with appliance	8	0.00	0.00
Annual software cost for Reporting Servers.* <i>Vendor to specify quantity</i>	Included with appliance	1	0.00	0.00
Annual License for filtering of client computers on K-12 network.	Licensing for 200,000 Computers, 280,000 Users for 1 year	280,000	\$0.60	\$120,000.00
Annual License for mobile computers. (see note 1 below.)	Licensing for 10,000 Mobile Clients	10,000	\$0.60	\$6,000.00
Technical support and upgrades/updates for filtering solution	Included at No Cost	1 year	0.00	0.00
One Day onsite training, 6 hours. Charleston WV (see note 2 below)	Tier 3 iBoss Engineer	1 day	\$1500.00	\$1500.00
Onsite installation, Charleston and Morgantown, WV (see note 2 below)	Tier 3 iBoss Engineer	4 days	\$1500.00	\$6000.00
Filtering Servers (if required)* <i>Vendor is to specify quantity</i>	IWF-14500-AX Enterprise SWG Filter w/10G Fiber Interface	8	\$6995.00	\$55,960.00
Reporting Servers (if required)* <i>Vendor is to specify quantity</i>	IWR-6900 RAID Reporter Internet Activity Logger/ Archiver	1	\$6995.00	\$6995.00
Other Hardware (if required)* <i>Vendor is to specify quantity</i>	Niagra 2801-SR Load Balancer	2	\$23,995.00	\$47,990.00
Hourly rate for custom system modifications	Included	20 hours	0.00	0.00
<b>Grand Total</b>				\$244,445.00



Phantom Technologies, Inc  
 9950 Summers Ridge Rd.  
 Building 160  
 San Diego, California 92121,  
 U.S.A  
 Phone: 877-742-6832 x 7817

**QUOTATION**

Quote# Qt23208

Bill To:
West Virginia DOE

Ship To:

Quote Date	Salesperson
11 Jun 2013	

Item	Description	Qty	Price	Discount(%)	Amount
IWF-14500X	IWF-14500X-8MA IBOSS ENTERPRISE 14500 HARDWARE.	8.00	6,995.00	0.00	55,960.00
IWR- 10GA	10 Gig Interface Card	8.00	0.00	0.00	0.00
Niagra Load Balancer	Niagra Load Balancer	2.00	23,995.00	0.00	47,990.00
IWR-6900-A	IWR-6900-A Enterprise External Reporter Appliance/Report Manager - Drill down reporting and archive. RAID	1.00	6,995.00	0.00	6,995.00
IWF-14500X-1S	IWF-14500-1S IBOSS ENTERPRISE 14500 1 YR SUBSCRIPTION Per Seat	200,000.00	0.60	0.00	120,000.00
IWF-14500X-1R	IWF-14500X-1R IBOSS ENTERPRISE 14500 HARDWARE REPLACEMENT WARRANTY. 1 YR	8.00	0.00	0.00	0.00
IWF-MCF Mobile Client	Mobile Client Integration	10,000.00	0.60	0.00	6,000.00
Onsite Installation	Onsite installation & integration by iboss certified Tier 3 support engineer. Pricing for both locations.	5.00	1,500.00	0.00	7,500.00
Mobile Ether MDM License	Mobile Ether Mobile Device Management. Cloud based SaaS.  *OPTIONAL: Add integrated mobile device management for iOS/Android devices at \$1.50/device. No additional hardware required.	0.00	1.50	0.00	0.00
Shipping		1.00	495.00	0.00	495.00

Sub Total: 244,940.00

**Total: \$244,940.00**

**Terms & Conditions**

This quotation contains proprietary information and is confidential, intended for use by your company only, and only for the user identified above. This quote is valid for 45 days from date listed.

PRODUCT DEMOS OFFER A 30 DAY TRIAL. AFTER 30 DAYS, AN INVOICE WILL BE ISSUED UNLESS EXTENSION REQUESTED AND APPROVED. PRODUCTS RETAINED BEYOND 30 DAYS WILL BECOME NON-RETURNABLE AND DUE UNLESS EXTENSION APPROVED IN WRITING. ALL RETURNS MUST BE ACCOMPANIED BY AN ISSUED RMA NUMBER. PHANTOM TECHNOLOGIES, INC IS RESPONSIBLE FOR OUTBOUND SHIPPING COST FOR EVALUATIONS. CUSTOMER IS RESPONSIBLE FOR ALL RETURN SHIPMENT COST ON EVALUATIONS. CUSTOMER IS RESPONSIBLE FOR INSURING ALL RETURNS AS WELL AS ANY TAXES OR CUSTOMS DUTIES. PRICES SUBJECT TO CHANGE - PRICES BASED UPON TOTAL PURCHASE - ALL DELIVERY, TRAINING OR CONSULTING SERVICES TO BE BILLED AT PUBLISHED RATES FOR EACH ACTIVITY INVOLVED UNLESS OTHERWISE SPECIFIED - GENERALLY ALL HARDWARE PROPOSED ABOVE ARE