



State of West Virginia
 Department of Administration
 Purchasing Division
 2019 Washington Street East
 Post Office Box 50130
 Charleston, WV 25305-0130

Solicitation

MILAM RIDGE

NUMBER
DEP16241

PAGE
1

ADDRESS CORRESPONDENCE TO ATTENTION OF
FRANK WHITTAKER 304-558-2316

VENDOR

*709045227 304-925-0253
 GREEN MOUNTAIN COMPANY
 511 50TH ST
 CHARLESTON WV 25304

SHIP TO

ENVIRONMENTAL PROTECTION
 DEPARTMENT OF
 OFFICE OF AML&R
 601 57TH STREET SE
 CHARLESTON, WV
 25304 304-926-0499

DATE PRINTED
05/15/2013

BID OPENING DATE: 06/25/2013

BID OPENING TIME 01:30PM

LINE	QUANTITY	UOP	CAT. NO	ITEM NUMBER	UNIT PRICE	AMOUNT
0001	1	JB		962-73		\$415,000-
<p>RECLAMATION: RESTORATION OF LAND & OTHER PROPERTIES</p> <p>REQUEST FOR SOLICITATION</p> <p>THE WEST VIRGINIA PURCHASING DIVISION, ON BEHALF OF WEST VIRGINIA DEPARTMENT OF ENVIRONMENTAL PROTECTION, IS SOLICITING BIDS FROM QUALIFIED CONTRACTORS FOR A CONTRACT TO PROVIDE ALL LABOR AND MATERIALS FOR THE RECLAMATION OF 10-AC ABANDONED MINE PROJECT KNOWN AS THE "MILAM RIDGE REFUSE PILES" PROJECT. THE SITE IS LOCATED AT COVEL, WEST VIRGINIA, (WYOMING CO).</p> <p>A MANDATORY ON SITE PREBID CONFERENCE SHALL BE HELD. PREBID WILL INVOLVE EXTENSIVE FOOT TRAVEL OVER DIFFICULT TERRAIN AND/OR DURING INCLEMENT WEATHER.</p> <p>THE PRE-BID MEETING DESCRIBED IN THIS SOLICITATION WILL INCLUDE A SITE VISIT OF RESTRICTED ACCESS AREAS. DUE TO THE ACCESS LIMITATIONS, ALL VENDORS MUST BE PRESENT AT THE PRE-BID MEETING AT THE TIME THE SITE VISIT OF THE RESTRICTED ACCESS AREA COMMENCES. ANY VENDOR NOT PRESENT AT THE PRE-BID MEETING WHEN THE SITE VISIT OF THE RESTRICTED ACCESS AREA BEGINS WILL BE DEEMED TO HAVE MISSED THE PRE-BID MEETING.</p> <p>DIRECTIONS TO PREBID:</p> <p>FROM CHARLESTON, TAKE I-64 EAST TO JUNCTION WITH WV-16 EXIT NUMBER 42, TOWARD ROBERT C. BYRD DRIVE/WV-97. MERGE ONTO WV-16 SOUTH TOWARD WV-97 WEST/SOPHIA/MULLEN</p>						

06/25/13 01:03:27 PM
 West Virginia Purchasing Division

SIGNATURE	TELEPHONE	DATE
<i>[Signature]</i>	304-925-0253	06/25/13
TITLE	FEIN	ADDRESS CHANGES TO BE NOTED ABOVE
PRESIDENT	55-0580174	

WHEN RESPONDING TO SOLICITATION, INSERT NAME AND ADDRESS IN SPACE ABOVE LABELED 'VENDOR'



State of West Virginia
 Department of Administration
 Purchasing Division
 2019 Washington Street East
 Post Office Box 50130
 Charleston, WV 25305-0130

Solicitation

NUMBER
DEP16241

PAGE
2

ADDRESS CORRESPONDENCE TO ATTENTION OF
FRANK WHITTAKER
304-558-2316

VENDOR

*709045227 304-925-0253
GREEN MOUNTAIN COMPANY
511 50TH ST

CHARLESTON WV 25304

SHIP TO

ENVIRONMENTAL PROTECTION
DEPARTMENT OF
OFFICE OF AML&R
601 57TH STREET SE
CHARLESTON, WV
25304 304-926-0499

DATE PRINTED
05/15/2013

BID OPENING DATE: **06/25/2013** BID OPENING TIME **01:30PM**

LINE	QUANTITY	UOP	CAT. NO.	ITEM NUMBER	UNIT PRICE	AMOUNT
<p>TURN LEFT ONTO WV-16/MORAN AVE. AND CONTINUE TO FOLLOW WV-16. TURN LEFT ONTO WV-10 AND FOLLOW TO THE TOWN OF GARWOOD. TURN LEFT FROM FROM WV-10 ONTO ACCESS ROAD APPROX. .5 MILES FROM THE RAILROAD TRESTLE IN GARWOOD.</p> <p>CONTACT & PHONE #: MARK PROCTOR, 304-465-1910</p> <p>PLANS & SPECS MAY BE OBTAINED BY THE FOLLOWING METHODS: 1) BY REQUEST, ON CD FROM THE WV DEPT. OF ENVIRONMENTAL PROTECTION, OFFICE OF AML & R, WITH NO CHARGE TO THE CONTRACTOR FOR THE CD OR MAILING. CALL LAWRENCE BURGESS, PH. 304-926-0499, EXT. 1668 OR 304-926-0485 TO ORDER CD. 2) PLANS AND SPECIFICATIONS WILL BE MADE AVAILABLE, ON CD, TO PRINT COMPANIES IN CHARLESTON, CLARKSBURG, AND OTHER AREAS UPON REQUEST. ***** THE CONTRACTOR WILL BE RESPONSIBLE FOR ALL PRINTING COSTS. *****</p> <p>*****</p> <p>AML CONTRACTOR INFORMATION FORM OMB #1029-0119 (EXPIRATION DATE: 01/31/2013) IS ATTACHED. YOU MUST COMPLETE THIS ORIGINAL FORM TO OBTAIN AN AVS DATA EVALUATION TO DETERMINE YOUR ELIGIBILITY AS AN AML CONTRACTOR. THIS IS A REQUIREMENT UNDER 30 CFR 874.16. IF THE ORIGINAL OMB #1029-0119 IS NOT ATTACHED TO THE BIDDING DOCUMENTS YOU CAN CONTACT THE AVS OFFICE AT 800-643-9748 OR WWW.AVS.OSMRE.GOV</p> <p>*****</p> <p>(1) GUARANTEE AND MAINTENANCE: (A) THE MATERIALS AND WORKMANSHIP AFFECTED BY</p>						

SIGNATURE *[Signature]* TELEPHONE **304-925-0253** DATE **06/25/13**
 TITLE **PRESIDENT** FERN **55-0580174** ADDRESS CHANGES TO BE NOTED ABOVE

WHEN RESPONDING TO SOLICITATION, INSERT NAME AND ADDRESS IN SPACE ABOVE LABELED 'VENDOR'



State of West Virginia
 Department of Administration
 Purchasing Division
 2019 Washington Street East
 Post Office Box 50130
 Charleston, WV 25305-0130

Solicitation

NUMBER
DEP16241

PAGE
3

ADDRESS CORRESPONDENCE TO ATTENTION OF:
FRANK WHITTAKER 304-558-2316

VENDOR

*709045227 304-925-0253
 GREEN MOUNTAIN COMPANY
 511 50TH ST
 CHARLESTON WV 25304

SHIP TO

ENVIRONMENTAL PROTECTION
 DEPARTMENT OF
 OFFICE OF AML&R
 601 57TH STREET SE
 CHARLESTON, WV
 25304 304-926-0499

DATE PRINTED
05/15/2013

BID OPENING DATE: **06/25/2013** BID OPENING TIME **01:30PM**

LINE	QUANTITY	UOP	CAT NO.	ITEM NUMBER	UNIT PRICE	AMOUNT
<p>THE CONTRACTOR ARE SUBJECT TO THE GUARANTEE ESTABLISHED BY CUSTOM OF THE RESPECTIVE TRADES. IN THE ABSENCE OF A TRADE GUARANTEE CUSTOM OR A SPECIAL GUARANTEE PROVISION, THE WORK, BOTH AS TO THE MATERIALS AND WORKMANSHIP, SHALL UPON ACCEPTANCE OF FINAL PAYMENT BY THE CONTRACTOR BE CONSIDERED GUARANTEED BY THE CONTRACTOR FOR ONE YEAR FROM THE DATE OF THE ACCEPTANCE OF THE WORK. NEITHER THE FINAL ACCEPTANCE NOR THE FINAL PAYMENT SHALL RELIEVE THE CONTRACTOR OF RESPONSIBILITY FOR NEGLIGENCE OR FAULTY MATERIALS, AND FOR DEFECTS APPEARING WITHIN THE GUARANTEE PERIOD SHALL BE REMEDIATED AT THE EXPENSE OF THE CONTRACTOR UPON WRITTEN NOTICE.</p> <p>(B) DURING THE ONE-YEAR GUARANTEE PERIOD, THE CONTRACTOR WILL MAINTAIN THE PROJECT TO THE CONDITIONS EXISTING AT THE DATE OF THE ACCEPTANCE OF THE WORK. ANY FAILURES DUE TO THE NEGLIGENCE OR WORKMANSHIP OF CONTRACTOR IN ANY OF THE WORK THAT DEVELOPS DURING THE GUARANTEE PERIOD SHALL BE CORRECTED BY THE CONTRACTOR AT ITS EXPENSE.</p> <p>(C) THE ONE-YEAR GUARANTEE PERIOD SHALL NOT BE CONSTRUED AS BEING AN EXTENSION OF THE PERFORMANCE TIME ALLOTTED FOR WORK UNDER THE CONTRACT.</p> <p>(D) GUARANTEES CONCERNING REVEGETATION MAY BE FURTHER DEFINED IN THE TECHNICAL SPECIFICATIONS CONTAINED HEREIN.</p> <p>(2) IT SHALL BE THE RESPONSIBILITY OF THE SUCCESSFUL VENDOR TO:</p> <p>(A) OBTAIN ALL NECESSARY DIVISION OF HIGHWAYS PERMITS FOR ALL TRANSPORTATION OF EQUIPMENT AND MATERIALS TO AND FROM THE JOB SITE.</p> <p>(B) OBTAIN ANY AND ALL REQUIRED CONSTRUCTION PERMITS OR RELATED JOB PERMITS.</p> <p>(3) TECHNICAL SPECIFICATIONS:</p>						

SIGNATURE	<i>Handwritten Signature</i>	TELEPHONE	304-925-0253	DATE	06/25/13
TITLE	PRESIDENT	FAX	55-0580174	ADDRESS CHANGES TO BE NOTED ABOVE	

WHEN RESPONDING TO SOLICITATION, INSERT NAME AND ADDRESS IN SPACE ABOVE LABELED 'VENDOR'



State of West Virginia
 Department of Administration
 Purchasing Division
 2019 Washington Street East
 Post Office Box 50130
 Charleston, WV 25305-0130

Solicitation

NUMBER
DEP16241

PAGE
4

ADDRESS CORRESPONDENCE TO ATTENTION OF:
FRANK WHITTAKER 304-558-2316

VENDOR

*709045227 304-925-0253
 GREEN MOUNTAIN COMPANY
 511 50TH ST
 CHARLESTON WV 25304

OFFICE

ENVIRONMENTAL PROTECTION
 DEPARTMENT OF
 OFFICE OF AML&R
 601 57TH STREET SE
 CHARLESTON, WV
 25304 304-926-0499

DATE PRINTED
05/15/2013

BID OPENING DATE: 06/25/2013 BID OPENING TIME 01:30PM

LINE	QUANTITY	UOP	CAT NO	ITEM NUMBER	UNIT PRICE	AMOUNT
<p>ALL WORK UNDER THIS CONTRACT SHALL BE IN ACCORDANCE WITH THE SPECIFICATIONS PREPARED FOR THE RECLAMATION OF THE "MILAM RIDGE REFUSE PILES" PROJECT. SAID PLANS & SPECS ARE INCORPORATED HERE IN BY REFERENCE AND ALL PROVISIONS, CLAUSES AND CONDITIONS THEREIN ARE MADE PROPERLY A PART OF THIS CONTRACT, AND CONSISTS OF 53 DRAWINGS AS PREPARED BY E. L. ROBINSON ENGINEERING.</p> <p>(4) PAYMENTS AND COMPLETION: THE CONTRACTOR SHALL FURNISH TO DEP AN APPLICATION FOR PAYMENT WITH AN ITEMIZED SCHEDULE OF VALUES AS HEREIN BEFORE REQUESTED. THE FORM INCLUDED IN THE SPECIFICATIONS SHALL BE USED FOR APPLICATIONS OF PAYMENT. IT IS THE DEP'S INTENT THAT THE PAYMENT TO THE CONTRACTOR BE MADE WITHIN 60 DAYS AFTER RECEIPT OF APPLICATION FOR PAYMENT.</p> <p>(5) APPLICATION FOR PARTIAL PAYMENT: THE CONTRACTOR MAY, ON A PERIODIC BASIS, SUBMIT FOR PARTIAL PAYMENT BASED ON THE AMOUNT OF WORK COMPLETED AT THE TIME OF THE SUBMITTAL. THE AMOUNT OF PAYMENT WILL BE DETERMINED FROM THE ACTUAL QUANTITY OF WORK COMPLETED IF BASED UPON UNIT MEASURES OR THE PERCENT COMPLETED IF BASED UPON A LUMP SUM.</p> <p>***** THIS IS THE END OF RFQ DEP16241 ***** TOTAL: \$ 415,000</p>						

SIGNATURE <i>Andy W...</i>	TELEPHONE 304-925-0253	DATE 06/25/13
TITLE PRESIDENT	PEIN 55-0580174	ADDRESS CHANGES TO BE NOTED ABOVE

WHEN RESPONDING TO SOLICITATION, INSERT NAME AND ADDRESS IN SPACE ABOVE LABELED 'VENDOR'

INSTRUCTIONS TO VENDORS SUBMITTING BIDS

1. **REVIEW DOCUMENTS THOROUGHLY:** The attached documents contain a solicitation for bids. Please read these instructions and all documents attached in their entirety. These instructions provide critical information about requirements that if overlooked could lead to disqualification of a Vendor's bid. All bids must be submitted in accordance with the provisions contained in these instructions and the Solicitation. Failure to do so may result in disqualification of Vendor's bid.
2. **MANDATORY TERMS:** The Solicitation may contain mandatory provisions identified by the use of the words "must," "will," and "shall." Failure to comply with a mandatory term in the Solicitation will result in bid disqualification.
3. **PREBID MEETING:** The item identified below shall apply to this Solicitation.

A pre-bid meeting will not be held prior to bid opening.

A **NON-MANDATORY PRE-BID** meeting will be held at the following place and time:

A **MANDATORY PRE-BID** meeting will be held at the following place and time:

06/06/2013 at 10:00 AM

Covel, WV
(Wyoming Co.)

All Vendors submitting a bid must attend the mandatory pre-bid meeting. Failure to attend the mandatory pre-bid meeting shall result in disqualification of the Vendor's bid. No one person attending the pre-bid meeting may represent more than one Vendor.

An attendance sheet provided at the pre-bid meeting shall serve as the official document verifying attendance. The State will not accept any other form of proof or documentation to verify attendance. Any person attending the pre-bid meeting on behalf of a Vendor must list on the attendance sheet his or her name and the name of the Vendor he or she is representing. Additionally, the person attending the pre-bid meeting should include the Vendor's E-Mail address, phone number, and Fax number on the attendance sheet. It is the Vendor's responsibility to locate the attendance sheet and provide the required

information. Failure to complete the attendance sheet as required may result in disqualification of Vendor's bid.

All Vendors should arrive prior to the starting time for the pre-bid. Vendors who arrive after the starting time but prior to the end of the pre-bid will be permitted to sign in, but are charged with knowing all matters discussed at the pre-bid.

Questions submitted at least five business days prior to a scheduled pre-bid will be discussed at the pre-bid meeting if possible. Any discussions or answers to questions at the pre-bid meeting are preliminary in nature and are non-binding. Official and binding answers to questions will be published in a written addendum to the Solicitation prior to bid opening.

- 4. **VENDOR QUESTION DEADLINE:** Vendors may submit questions relating to this Solicitation to the Purchasing Division. Questions must be submitted in writing. All questions must be submitted on or before the date listed below and to the address listed below in order to be considered. A written response will be published in a Solicitation addendum if a response is possible and appropriate. Non-written discussions, conversations, or questions and answers regarding this Solicitation are preliminary in nature and are non-binding.

Question Submission Deadline: 06/11/2013

Submit Questions to:

Frank Whittaker
 2019 Washington Street, East
 P.O. Box 50130
 Charleston, WV 25305
 Fax: 304-558-4115
 Email: frank.m.whittaker@wv.gov

- 5. **VERBAL COMMUNICATION:** Any verbal communication between the Vendor and any State personnel is not binding, including that made at the mandatory pre-bid conference. Only information issued in writing and added to the Solicitation by an official written addendum by the Purchasing Division is binding.
- 6. **BID SUBMISSION:** All bids must be signed and delivered by the Vendor to the Purchasing Division at the address listed below on or before the date and time of the bid opening. Any bid received by the Purchasing Division staff is considered to be in the possession of the Purchasing Division and will not be returned for any reason. The bid delivery address is:

Department of Administration, Purchasing Division
 2019 Washington Street East
 P.O. Box 50130,
 Charleston, WV 25305-0130

The bid should contain the information listed below on the face of the envelope or the bid may not be considered:

SEALED BID

BUYER: _____
 SOLICITATION NO.: _____
 BID OPENING DATE: _____
 BID OPENING TIME: _____
 FAX NUMBER: _____

In the event that Vendor is responding to a request for proposal, the Vendor shall submit one original technical and one original cost proposal plus convenience copies of each to the Purchasing Division at the address shown above. Additionally, the Vendor should identify the bid type as either a technical or cost proposal on the face of each bid envelope submitted in response to a request for proposal as follows:

BID TYPE: [] Technical
 [] Cost

7. **BID OPENING:** Bids submitted in response to this Solicitation will be opened at the location identified below on the date and time listed below. Delivery of a bid after the bid opening date and time will result in bid disqualification. For purposes of this Solicitation, a bid is considered delivered when time stamped by the official Purchasing Division time clock.

Bid Opening Date and Time:

06/25/2013 at 1:30 PM

Bid Opening Location:

Department of Administration, Purchasing Division
 2019 Washington Street East
 P.O. Box 50130,
 Charleston, WV 25305-0130

8. **ADDENDUM ACKNOWLEDGEMENT:** Changes or revisions to this Solicitation will be made by an official written addendum issued by the Purchasing Division. Vendor should acknowledge receipt of all addenda issued with this Solicitation by completing an Addendum Acknowledgment Form, a copy of which is included herewith. Failure to acknowledge addenda may result in bid disqualification. The addendum acknowledgement should be submitted with the bid to expedite document processing.
9. **BID FORMATTING:** Vendor should type or electronically enter the information onto its bid to prevent errors in the evaluation. Failure to type or electronically enter the information may result in bid disqualification.

GENERAL TERMS AND CONDITIONS:

1. **CONTRACTUAL AGREEMENT:** Issuance of a Purchase Order signed by the Purchasing Division Director, or his designee, and approved as to form by the Attorney General's office constitutes acceptance of this Contract made by and between the State of West Virginia and the Vendor. Vendor's signature on its bid signifies Vendor's agreement to be bound by and accept the terms and conditions contained in this Contract.

2. **DEFINITIONS:** As used in this Solicitation / Contract, the following terms shall have the meanings attributed to them below. Additional definitions may be found in the specifications included with this Solicitation / Contract.
 - 2.1 **"Agency" or "Agencies"** means the agency, board, commission, or other entity of the State of West Virginia that is identified on the first page of the Solicitation or any other public entity seeking to procure goods or services under this Contract.

 - 2.2 **"Contract"** means the binding agreement that is entered into between the State and the Vendor to provide the goods and services requested in the Solicitation.

 - 2.3 **"Director"** means the Director of the West Virginia Department of Administration, Purchasing Division.

 - 2.4 **"Purchasing Division"** means the West Virginia Department of Administration, Purchasing Division.

 - 2.5 **"Purchase Order"** means the document signed by the Agency and the Purchasing Division, and approved as to form by the Attorney General, that identifies the Vendor as the successful bidder and Contract holder.

 - 2.6 **"Solicitation"** means the official solicitation published by the Purchasing Division and identified by number on the first page thereof.

 - 2.7 **"State"** means the State of West Virginia and/or any of its agencies, commissions, boards, etc. as context requires.

 - 2.8 **"Vendor" or "Vendors"** means any entity submitting a bid in response to the Solicitation, the entity that has been selected as the lowest responsible bidder, or the entity that has been awarded the Contract as context requires.

3. **CONTRACT TERM; RENEWAL; EXTENSION:** The term of this Contract shall be determined in accordance with the category that has been identified as applicable to this Contract below:

Term Contract

Initial Contract Term: This Contract becomes effective on

and extends for a period of year(s).

Renewal Term: This Contract may be renewed upon the mutual written consent of the Agency, and the Vendor, with approval of the Purchasing Division and the Attorney General's office (Attorney General approval is as to form only). Any request for renewal must be submitted to the Purchasing Division Director thirty (30) days prior to the expiration date of the initial contract term or appropriate renewal term. A Contract renewal shall be in accordance with the terms and conditions of the original contract. Renewal of this Contract is limited to successive one (1) year periods. Automatic renewal of this Contract is prohibited. Notwithstanding the foregoing, Purchasing Division approval is not required on agency delegated or exempt purchases. Attorney General approval may be required for vendor terms and conditions.

Reasonable Time Extension: At the sole discretion of the Purchasing Division Director, and with approval from the Attorney General's office (Attorney General approval is as to form only), this Contract may be extended for a reasonable time after the initial Contract term or after any renewal term as may be necessary to obtain a new contract or renew this Contract. Any reasonable time extension shall not exceed twelve (12) months. Vendor may avoid a reasonable time extension by providing the Purchasing Division Director with written notice of Vendor's desire to terminate this Contract 30 days prior to the expiration of the then current term. During any reasonable time extension period, the Vendor may terminate this Contract for any reason upon giving the Purchasing Division Director 30 days written notice. Automatic extension of this Contract is prohibited. Notwithstanding the foregoing, Purchasing Division approval is not required on agency delegated or exempt purchases, but Attorney General approval may be required.

Fixed Period Contract: This Contract becomes effective upon Vendor's receipt of the notice to proceed and must be completed within days.

One Time Purchase: The term of this Contract shall run from the issuance of the Purchase Order until all of the goods contracted for have been delivered, but in no event shall this Contract extend for more than one fiscal year.

Other: See attached.

4. **NOTICE TO PROCEED:** Vendor shall begin performance of this Contract immediately upon receiving notice to proceed unless otherwise instructed by the Agency. Unless otherwise specified, the fully executed Purchase Order will be considered notice to proceed
5. **QUANTITIES:** The quantities required under this Contract shall be determined in accordance with the category that has been identified as applicable to this Contract below.
- Open End Contract:** Quantities listed in this Solicitation are approximations only, based on estimates supplied by the Agency. It is understood and agreed that the Contract shall cover the quantities actually ordered for delivery during the term of the Contract, whether more or less than the quantities shown.
- Service:** The scope of the service to be provided will be more clearly defined in the specifications included herewith.
- Combined Service and Goods:** The scope of the service and deliverable goods to be provided will be more clearly defined in the specifications included herewith.
- One Time Purchase:** This Contract is for the purchase of a set quantity of goods that are identified in the specifications included herewith. Once those items have been delivered, no additional goods may be procured under this Contract without an appropriate change order approved by the Vendor, Agency, Purchasing Division, and Attorney General's office.
6. **PRICING:** The pricing set forth herein is firm for the life of the Contract, unless specified elsewhere within this Solicitation/Contract by the State. A Vendor's inclusion of price adjustment provisions in its bid, without an express authorization from the State in the Solicitation to do so, may result in bid disqualification.
7. **EMERGENCY PURCHASES:** The Purchasing Division Director may authorize the Agency to purchase goods or services in the open market that Vendor would otherwise provide under this Contract if those goods or services are for immediate or expedited delivery in an emergency. Emergencies shall include, but are not limited to, delays in transportation or an unanticipated increase in the volume of work. An emergency purchase in the open market, approved by the Purchasing Division Director, shall not constitute a breach of this Contract and shall not entitle the Vendor to any form of compensation or damages. This provision does not excuse the State from fulfilling its obligations under a One Time Purchase contract.
8. **REQUIRED DOCUMENTS:** All of the items checked below must be provided to the Purchasing Division by the Vendor as specified below.
- BID BOND:** All Vendors shall furnish a bid bond in the amount of five percent (5%) of the total amount of the bid protecting the State of West Virginia. The bid bond must be submitted with the bid.

PERFORMANCE BOND: The apparent successful Vendor shall provide a performance bond in the amount of . The performance bond must be issued and received by the Purchasing Division prior to Contract award. On construction contracts, the performance bond must be 100% of the Contract value.

LABOR/MATERIAL PAYMENT BOND: The apparent successful Vendor shall provide a labor/material payment bond in the amount of 100% of the Contract value. The labor/material payment bond must be issued and delivered to the Purchasing Division prior to Contract award.

In lieu of the Bid Bond, Performance Bond, and Labor/Material Payment Bond, the Vendor may provide certified checks, cashier's checks, or irrevocable letters of credit. Any certified check, cashier's check, or irrevocable letter of credit provided in lieu of a bond must be of the same amount and delivered on the same schedule as the bond it replaces. A letter of credit submitted in lieu of a performance and labor/material payment bond will only be allowed for projects under \$100,000. Personal or business checks are not acceptable.

MAINTENANCE BOND: The apparent successful Vendor shall provide a two (2) year maintenance bond covering the roofing system. The maintenance bond must be issued and delivered to the Purchasing Division prior to Contract award.

WORKERS' COMPENSATION INSURANCE: The apparent successful Vendor shall have appropriate workers' compensation insurance and shall provide proof thereof upon request.

INSURANCE: The apparent successful Vendor shall furnish proof of the following insurance prior to Contract award:

Commercial General Liability Insurance:
 or more.

Builders Risk Insurance: builders risk – all risk insurance in an amount equal to 100% of the amount of the Contract.

The apparent successful Vendor shall also furnish proof of any additional insurance requirements contained in the specifications prior to Contract award regardless of whether or not that insurance requirement is listed above.

[] **LICENSE(S) / CERTIFICATIONS / PERMITS:** In addition to anything required under the Section entitled Licensing, of the General Terms and Conditions, the apparent successful Vendor shall furnish proof of the following licenses, certifications, and/or permits prior to Contract award, in a form acceptable to the Purchasing Division.

[]

[]

[]

[]

The apparent successful Vendor shall also furnish proof of any additional licenses or certifications contained in the specifications prior to Contract award regardless of whether or not that requirement is listed above.

9. **LITIGATION BOND:** The Director reserves the right to require any Vendor that files a protest of an award to submit a litigation bond in the amount equal to one percent of the lowest bid submitted or \$5,000, whichever is greater. The entire amount of the bond shall be forfeited if the hearing officer determines that the protest was filed for frivolous or improper purpose, including but not limited to, the purpose of harassing, causing unnecessary delay, or needless expense for the Agency. All litigation bonds shall be made payable to the Purchasing Division. In lieu of a bond, the protester may submit a cashier's check or certified check payable to the Purchasing Division. Cashier's or certified checks will be deposited with and held by the State Treasurer's office. If it is determined that the protest has not been filed for frivolous or improper purpose, the bond or deposit shall be returned in its entirety.

10. **ALTERNATES:** Any model, brand, or specification listed herein establishes the acceptable level of quality only and is not intended to reflect a preference for, or in any way favor, a particular brand or vendor. Vendors may bid alternates to a listed model or brand provided that the alternate is at least equal to the model or brand and complies with the required specifications. The equality of any alternate being bid shall be determined by the State at its sole discretion. Any Vendor bidding an alternate model or brand should clearly identify the alternate items in its bid and should include manufacturer's specifications, industry literature, and/or any other relevant documentation demonstrating the equality of the alternate items. Failure to provide information for alternate items may be grounds for rejection of a Vendor's bid.

11. **EXCEPTIONS AND CLARIFICATIONS:** The Solicitation contains the specifications that shall form the basis of a contractual agreement. Vendor shall clearly mark any exceptions, clarifications, or

other proposed modifications in its bid. Exceptions to, clarifications of, or modifications of a requirement or term and condition of the Solicitation may result in bid disqualification.

12. LIQUIDATED DAMAGES: Vendor shall pay liquidated damages in the amount

Two Hundred Fifty Dollars (\$250.00) per day	for	each day of delay

This clause shall in no way be considered exclusive and shall not limit the State or Agency's right to pursue any other available remedy.

13. ACCEPTANCE/REJECTION: The State may accept or reject any bid in whole, or in part. Vendor's signature on its bid signifies acceptance of the terms and conditions contained in the Solicitation and Vendor agrees to be bound by the terms of the Contract, as reflected in the Purchase Order, upon receipt.

14. REGISTRATION: Prior to Contract award, the apparent successful Vendor must be properly registered with the West Virginia Purchasing Division and must have paid the \$125 fee if applicable.

15. COMMUNICATION LIMITATIONS: In accordance with West Virginia Code of State Rules §148-1-6.6, communication with the State of West Virginia or any of its employees regarding this Solicitation during the solicitation, bid, evaluation or award periods, except through the Purchasing Division, is strictly prohibited without prior Purchasing Division approval. Purchasing Division approval for such communication is implied for all agency delegated and exempt purchases.

16. FUNDING: This Contract shall continue for the term stated herein, contingent upon funds being appropriated by the Legislature or otherwise being made available. In the event funds are not appropriated or otherwise made available, this Contract becomes void and of no effect beginning on July 1 of the fiscal year for which funding has not been appropriated or otherwise made available.

17. PAYMENT: Payment in advance is prohibited under this Contract. Payment may only be made after the delivery and acceptance of goods or services. The Vendor shall submit invoices, in arrears, to the Agency at the address on the face of the purchase order labeled "Invoice To."

18. UNIT PRICE: Unit prices shall prevail in cases of a discrepancy in the Vendor's bid.

19. DELIVERY: All quotations are considered freight on board destination ("F.O.B. destination") unless alternate shipping terms are clearly identified in the bid. Vendor's listing of shipping terms that contradict the shipping terms expressly required by this Solicitation may result in bid disqualification.

20. INTEREST: Interest attributable to late payment will only be permitted if authorized by the West Virginia Code. Presently, there is no provision in the law for interest on late payments.

21. PREFERENCE: Vendor Preference may only be granted upon written request and only in accordance with the West Virginia Code § 5A-3-37 and the West Virginia Code of State Rules. A Resident Vendor Certification form has been attached hereto to allow Vendor to apply for the preference. Vendor's

failure to submit the Resident Vendor Certification form with its bid will result in denial of Vendor Preference. Vendor Preference does not apply to construction projects.

- 22. SMALL, WOMEN-OWNED, OR MINORITY-OWNED BUSINESSES:** For any solicitations publicly advertised for bid on or after July 1, 2012, in accordance with West Virginia Code §5A-3-37(a)(7) and W. Va. CSR § 148-22-9, any non-resident vendor certified as a small, women-owned, or minority-owned business under W. Va. CSR § 148-22-9 shall be provided the same preference made available to any resident vendor. Any non-resident small, women-owned, or minority-owned business must identify itself as such in writing, must submit that writing to the Purchasing Division with its bid, and must be properly certified under W. Va. CSR § 148-22-9 prior to submission of its bid to receive the preferences made available to resident vendors. Preference for a non-resident small, women-owned, or minority owned business shall be applied in accordance with W. Va. CSR § 148-22-9.
- 23. TAXES:** The Vendor shall pay any applicable sales, use, personal property or any other taxes arising out of this Contract and the transactions contemplated thereby. The State of West Virginia is exempt from federal and state taxes and will not pay or reimburse such taxes.
- 24. CANCELLATION:** The Purchasing Division Director reserves the right to cancel this Contract immediately upon written notice to the vendor if the materials or workmanship supplied do not conform to the specifications contained in the Contract. The Purchasing Division Director may cancel any purchase or Contract upon 30 days written notice to the Vendor in accordance with West Virginia Code of State Rules § 148-1-7.16.2.
- 25. WAIVER OF MINOR IRREGULARITIES:** The Director reserves the right to waive minor irregularities in bids or specifications in accordance with West Virginia Code of State Rules § 148-1-4.6.
- 26. TIME:** Time is of the essence with regard to all matters of time and performance in this Contract.
- 27. APPLICABLE LAW:** This Contract is governed by and interpreted under West Virginia law without giving effect to its choice of law principles. Any information provided in specification manuals, or any other source, verbal or written, which contradicts or violates the West Virginia Constitution, West Virginia Code or West Virginia Code of State Rules is void and of no effect.
- 28. COMPLIANCE:** Vendor shall comply with all applicable federal, state, and local laws, regulations and ordinances. By submitting a bid, Vendors acknowledge that they have reviewed, understand, and will comply with all applicable law.
- 29. PREVAILING WAGE:** On any contract for the construction of a public improvement, Vendor and any subcontractors utilized by Vendor shall pay a rate or rates of wages which shall not be less than the fair minimum rate or rates of wages (prevailing wage), as established by the West Virginia Division of Labor under West Virginia Code §§ 21-5A-1 et seq. and available at <http://www.sos.wv.gov/administrative-law/wagerates/Pages/default.aspx>. Vendor shall be responsible for ensuring compliance with prevailing wage requirements and determining when prevailing wage

requirements are applicable. The required contract provisions contained in West Virginia Code of State Rules § 42-7-3 are specifically incorporated herein by reference.

- 30. ARBITRATION:** Any references made to arbitration contained in this Contract, Vendor's bid, or in any American Institute of Architects documents pertaining to this Contract are hereby deleted, void, and of no effect.
- 31. MODIFICATIONS:** This writing is the parties' final expression of intent. Notwithstanding anything contained in this Contract to the contrary, no modification of this Contract shall be binding without mutual written consent of the Agency, and the Vendor, with approval of the Purchasing Division and the Attorney General's office (Attorney General approval is as to form only). **No Change shall be implemented by the Vendor until such time as the Vendor receives an approved written change order from the Purchasing Division.**
- 32. WAIVER:** The failure of either party to insist upon a strict performance of any of the terms or provision of this Contract, or to exercise any option, right, or remedy herein contained, shall not be construed as a waiver or a relinquishment for the future of such term, provision, option, right, or remedy, but the same shall continue in full force and effect. Any waiver must be expressly stated in writing and signed by the waiving party.
- 33. SUBSEQUENT FORMS:** The terms and conditions contained in this Contract shall supersede any and all subsequent terms and conditions which may appear on any form documents submitted by Vendor to the Agency or Purchasing Division such as price lists, order forms, invoices, sales agreements, or maintenance agreements, and includes internet websites or other electronic documents. Acceptance or use of Vendor's forms does not constitute acceptance of the terms and conditions contained thereon.
- 34. ASSIGNMENT:** Neither this Contract nor any monies due, or to become due hereunder, may be assigned by the Vendor without the express written consent of the Agency, the Purchasing Division, the Attorney General's office (as to form only), and any other government agency or office that may be required to approve such assignments. Notwithstanding the foregoing, Purchasing Division approval may or may not be required on certain agency delegated or exempt purchases.
- 35. WARRANTY:** The Vendor expressly warrants that the goods and/or services covered by this Contract will: (a) conform to the specifications, drawings, samples, or other description furnished or specified by the Agency; (b) be merchantable and fit for the purpose intended; and (c) be free from defect in material and workmanship.
- 36. STATE EMPLOYEES:** State employees are not permitted to utilize this Contract for personal use and the Vendor is prohibited from permitting or facilitating the same.
- 37. BANKRUPTCY:** In the event the Vendor files for bankruptcy protection, the State of West Virginia may deem this Contract null and void, and terminate this Contract without notice.

- 38. HIPAA BUSINESS ASSOCIATE ADDENDUM:** The West Virginia State Government HIPAA Business Associate Addendum (BAA), approved by the Attorney General, is available online at <http://www.state.wv.us/admin/purchase/vrc/hipaa.html> and is hereby made part of the agreement provided that the Agency meets the definition of a Covered entity (45 CFR §160.103) and will be disclosing Protected Health Information (45 CFR §160.103) to the Vendor. Additionally, the HIPAA Privacy, Security, Enforcement & Breach Notification Final Omnibus Rule was published on January 25, 2013. It may be viewed online at <http://www.gpo.gov/fdsys/pkg/FR-2013-01-25/pdf/2013-01073.pdf>. Any organization, that qualifies as the Agency's Business Associate, is expected to be in compliance with this Final Rule. For those Business Associates entering into contracts with a HIPAA Covered State Agency between January 25, 2013 and the release of the 2013 WV State Agency Business Associate Agreement, or September 23, 2013 (whichever is earlier), be advised that you will be required to comply with the 2013 WV State Agency Business Associate Agreement. For those Business Associates with contracts with a HIPAA Covered State Agency executed prior to January 25, 2013, be advised that upon renewal or modification, you will be required to comply with the 2013 WV State Agency Business Associate Agreement no later than September 22, 2014.
- 39. CONFIDENTIALITY:** The Vendor agrees that it will not disclose to anyone, directly or indirectly, any such personally identifiable information or other confidential information gained from the Agency, unless the individual who is the subject of the information consents to the disclosure in writing or the disclosure is made pursuant to the Agency's policies, procedures, and rules. Vendor further agrees to comply with the Confidentiality Policies and Information Security Accountability Requirements, set forth in <http://www.state.wv.us/admin/purchase/privacy/default.html>.
- 40. DISCLOSURE:** Vendor's response to the Solicitation and the resulting Contract are considered public documents and will be disclosed to the public in accordance with the laws, rules, and policies governing the West Virginia Purchasing Division. Those laws include, but are not limited to, the Freedom of Information Act found in West Virginia Code § 29B-1-1 et seq.

If a Vendor considers any part of its bid to be exempt from public disclosure, Vendor must so indicate by specifically identifying the exempt information, identifying the exemption that applies, providing a detailed justification for the exemption, segregating the exempt information from the general bid information, and submitting the exempt information as part of its bid but in a segregated and clearly identifiable format. Failure to comply with the foregoing requirements will result in public disclosure of the Vendor's bid without further notice. A Vendor's act of marking all or nearly all of its bid as exempt is not sufficient to avoid disclosure and WILL NOT BE HONORED. Vendor's act of marking a bid or any part thereof as "confidential" or "proprietary" is not sufficient to avoid disclosure and WILL NOT BE HONORED. In addition, a legend or other statement indicating that all or substantially all of the bid is exempt from disclosure is not sufficient to avoid disclosure and WILL NOT BE HONORED. Vendor will be required to defend any claimed exemption for nondisclosure in the event of an administrative or judicial challenge to the State's nondisclosure. Vendor must indemnify the State for any costs incurred related to any exemptions claimed by Vendor. Any questions regarding the applicability of the various public records laws should be addressed to your own legal counsel prior to bid submission.

- 41. LICENSING:** In accordance with West Virginia Code of State Rules §148-1-6.1.7, Vendor must be licensed and in good standing in accordance with any and all state and local laws and requirements by any state or local agency of West Virginia, including, but not limited to, the West Virginia Secretary of State's Office, the West Virginia Tax Department, West Virginia Insurance Commission, or any other state agency or political subdivision. Upon request, the Vendor must provide all necessary releases to obtain information to enable the Purchasing Division Director or the Agency to verify that the Vendor is licensed and in good standing with the above entities.
- 42. ANTITRUST:** In submitting a bid to, signing a contract with, or accepting a Purchase Order from any agency of the State of West Virginia, the Vendor agrees to convey, sell, assign, or transfer to the State of West Virginia all rights, title, and interest in and to all causes of action it may now or hereafter acquire under the antitrust laws of the United States and the State of West Virginia for price fixing and/or unreasonable restraints of trade relating to the particular commodities or services purchased or acquired by the State of West Virginia. Such assignment shall be made and become effective at the time the purchasing agency tenders the initial payment to Vendor.
- 43. VENDOR CERTIFICATIONS:** By signing its bid or entering into this Contract, Vendor certifies (1) that its bid was made without prior understanding, agreement, or connection with any corporation, firm, limited liability company, partnership, person or entity submitting a bid for the same material, supplies, equipment or services; (2) that its bid is in all respects fair and without collusion or fraud; (3) that this Contract is accepted or entered into without any prior understanding, agreement, or connection to any other entity that could be considered a violation of law; and (4) that it has reviewed this RFQ in its entirety; understands the requirements, terms and conditions, and other information contained herein. Vendor's signature on its bid also affirms that neither it nor its representatives have any interest, nor shall acquire any interest, direct or indirect, which would compromise the performance of its services hereunder. Any such interests shall be promptly presented in detail to the Agency.

The individual signing this bid on behalf of Vendor certifies that he or she is authorized by the Vendor to execute this bid or any documents related thereto on Vendor's behalf; that he or she is authorized to bind the Vendor in a contractual relationship; and that, to the best of his or her knowledge, the Vendor has properly registered with any State agency that may require registration.

- 44. PURCHASING CARD ACCEPTANCE:** The State of West Virginia currently utilizes a Purchasing Card program, administered under contract by a banking institution, to process payment for goods and services. The Vendor must accept the State of West Virginia's Purchasing Card for payment of all orders under this Contract unless the box below is checked.

Vendor is not required to accept the State of West Virginia's Purchasing Card as payment for all goods and services.

- 45. VENDOR RELATIONSHIP:** The relationship of the Vendor to the State shall be that of an independent contractor and no principal-agent relationship or employer-employee relationship is contemplated or created by this Contract. The Vendor as an independent contractor is solely liable for the acts and omissions of its employees and agents. Vendor shall be responsible for selecting,

supervising, and compensating any and all individuals employed pursuant to the terms of this Solicitation and resulting contract. Neither the Vendor, nor any employees or subcontractors of the Vendor, shall be deemed to be employees of the State for any purpose whatsoever. Vendor shall be exclusively responsible for payment of employees and contractors for all wages and salaries, taxes, withholding payments, penalties, fees, fringe benefits, professional liability insurance premiums, contributions to insurance and pension, or other deferred compensation plans, including but not limited to, Workers' Compensation and Social Security obligations, licensing fees, *etc.* and the filing of all necessary documents, forms and returns pertinent to all of the foregoing. Vendor shall hold harmless the State, and shall provide the State and Agency with a defense against any and all claims including, but not limited to, the foregoing payments, withholdings; contributions, taxes, Social Security taxes, and employer income tax returns.

- 46. INDEMNIFICATION:** The Vendor agrees to indemnify, defend, and hold harmless the State and the Agency, their officers, and employees from and against: (1) Any claims or losses for services rendered by any subcontractor, person, or firm performing or supplying services, materials, or supplies in connection with the performance of the Contract; (2) Any claims or losses resulting to any person or entity injured or damaged by the Vendor, its officers, employees, or subcontractors by the publication, translation, reproduction, delivery, performance, use, or disposition of any data used under the Contract in a manner not authorized by the Contract, or by Federal or State statutes or regulations; and (3) Any failure of the Vendor, its officers, employees, or subcontractors to observe State and Federal laws including, but not limited to, labor and wage and hour laws.
- 47. PURCHASING AFFIDAVIT:** In accordance with West Virginia Code § 5A-3-10a, all Vendors are required to sign, notarize, and submit the Purchasing Affidavit stating that neither the Vendor nor a related party owe a debt to the State in excess of \$1,000. The affidavit must be submitted prior to award, but should be submitted with the Vendor's bid. A copy of the Purchasing Affidavit is included herewith.
- 48. ADDITIONAL AGENCY AND LOCAL GOVERNMENT USE:** This Contract may be utilized by and extends to other agencies, spending units, and political subdivisions of the State of West Virginia; county, municipal, and other local government bodies; and school districts ("Other Government Entities"). This Contract shall be extended to the aforementioned Other Government Entities on the same prices, terms, and conditions as those offered and agreed to in this Contract. If the Vendor does not wish to extend the prices, terms, and conditions of its bid and subsequent contract to the Other Government Entities, the Vendor must clearly indicate such refusal in its bid. A refusal to extend this Contract to the Other Government Entities shall not impact or influence the award of this Contract in any manner.
- 49. CONFLICT OF INTEREST:** Vendor, its officers or members or employees, shall not presently have or acquire any interest, direct or indirect, which would conflict with or compromise the performance of its obligations hereunder. Vendor shall periodically inquire of its officers, members and employees to ensure that a conflict of interest does not arise. Any conflict of interest discovered shall be promptly presented in detail to the Agency.

50. REPORTS: Vendor shall provide the Agency and/or the Purchasing Division with the following reports identified by a checked box below:

- Such reports as the Agency and/or the Purchasing Division may request. Requested reports may include, but are not limited to, quantities purchased, agencies utilizing the contract, total contract expenditures by agency, etc.
- Quarterly reports detailing the total quantity of purchases in units and dollars, along with a listing of purchases by agency. Quarterly reports should be delivered to the Purchasing Division via email at purchasing.requisitions@wv.gov.

51. BACKGROUND CHECK: In accordance with W. Va. Code § 15-2D-3, the Director of the Division of Protective Services shall require any service provider whose employees are regularly employed on the grounds or in the buildings of the Capitol complex or who have access to sensitive or critical information to submit to a fingerprint-based state and federal background inquiry through the state repository. The service provider is responsible for any costs associated with the fingerprint-based state and federal background inquiry.

After the contract for such services has been approved, but before any such employees are permitted to be on the grounds or in the buildings of the Capitol complex or have access to sensitive or critical information, the service provider shall submit a list of all persons who will be physically present and working at the Capitol complex to the Director of the Division of Protective Services for purposes of verifying compliance with this provision.

The State reserves the right to prohibit a service provider's employees from accessing sensitive or critical information or to be present at the Capitol complex based upon results addressed from a criminal background check.

Service providers should contact the West Virginia Division of Protective Services by phone at (304) 558-9911 for more information.

52. PREFERENCE FOR USE OF DOMESTIC STEEL PRODUCTS: Except when authorized by the Director of the Purchasing Division pursuant to W. Va. Code § 5A-3-56, no contractor may use or supply steel products for a State Contract Project other than those steel products made in the United States. A contractor who uses steel products in violation of this section may be subject to civil penalties pursuant to W. Va. Code § 5A-3-56. As used in this section:

- a. "State Contract Project" means any erection or construction of, or any addition to, alteration of or other improvement to any building or structure, including, but not limited to, roads or highways, or the installation of any heating or cooling or ventilating plants or other equipment, or the supply of and materials for such projects, pursuant to a contract with the State of West Virginia for which bids were solicited on or after June 6, 2001.
- b. "Steel Products" means products rolled, formed, shaped, drawn, extruded, forged, cast, fabricated or otherwise similarly processed, or processed by a combination of two or more or

such operations, from steel made by the open heath, basic oxygen, electric furnace, Bessemer or other steel making process.

The Purchasing Division Director may, in writing, authorize the use of foreign steel products if:

- a. The cost for each contract item used does not exceed one tenth of one percent (.1%) of the total contract cost or two thousand five hundred dollars (\$2,500.00), whichever is greater. For the purposes of this section, the cost is the value of the steel product as delivered to the project; or
- b. The Director of the Purchasing Division determines that specified steel materials are not produced in the United States in sufficient quantity or otherwise are not reasonably available to meet contract requirements.

53. PREFERENCE FOR USE OF DOMESTIC ALUMINUM, GLASS, AND STEEL: In Accordance with W. Va. Code § 5-19-1 et seq., and W. Va. CSR § 148-10-1 et seq., for every contract or subcontract, subject to the limitations contained herein, for the construction, reconstruction, alteration, repair, improvement or maintenance of public works or for the purchase of any item of machinery or equipment to be used at sites of public works, only domestic aluminum, glass or steel products shall be supplied unless the spending officer determines, in writing, after the receipt of offers or bids, (1) that the cost of domestic aluminum, glass or steel products is unreasonable or inconsistent with the public interest of the State of West Virginia, (2) that domestic aluminum, glass or steel products are not produced in sufficient quantities to meet the contract requirements, or (3) the available domestic aluminum, glass, or steel do not meet the contract specifications. This provision only applies to public works contracts awarded in an amount more than fifty thousand dollars (\$50,000) or public works contracts that require more than ten thousand pounds of steel products.

The cost of domestic aluminum, glass, or steel products may be unreasonable if the cost is more than twenty percent (20%) of the bid or offered price for foreign made aluminum, glass, or steel products. If the domestic aluminum, glass or steel products to be supplied or produced in a "substantial labor surplus area", as defined by the United States Department of Labor, the cost of domestic aluminum, glass, or steel products may be unreasonable if the cost is more than thirty percent (30%) of the bid or offered price for foreign made aluminum, glass, or steel products.

This preference shall be applied to an item of machinery or equipment, as indicated above, when the item is a single unit of equipment or machinery manufactured primarily of aluminum, glass or steel, is part of a public works contract and has the sole purpose or of being a permanent part of a single public works project. This provision does not apply to equipment or machinery purchased by a spending unit for use by that spending unit and not as part of a single public works project.

All bids and offers including domestic aluminum, glass or steel products that exceed bid or offer prices including foreign aluminum, glass or steel products after application of the preferences provided in this provision may be reduced to a price equal to or lower than the lowest bid or offer price for foreign aluminum, glass or steel products plus the applicable preference. If the reduced bid or offer prices are made in writing and supersede the prior bid or offer prices, all bids or offers, including the reduced bid or offer prices, will be reevaluated in accordance with this rule.

ADDITIONAL TERMS AND CONDITIONS (Construction Contracts Only)

1. **CONTRACTOR'S LICENSE:** West Virginia Code § 21-11-2 requires that all persons desiring to perform contracting work in this state be licensed. The West Virginia Contractors Licensing Board is empowered to issue the contractor's license. Applications for a contractor's license may be made by contacting the West Virginia Division of Labor.

West Virginia Code § 21-11-11 requires any prospective Vendor to include the contractor's license number on its bid. Failure to include a contractor's license number on the bid shall result in Vendor's bid being disqualified. Vendors should include a contractor's license number in the space provided below.

Contractor's Name: GREEN MOUNTAIN COMPANY

Contractor's License No. WV 002057

The apparent successful Vendor must furnish a copy of its contractor's license prior to the issuance of a purchase order/contract.

2. **DRUG-FREE WORKPLACE:** W. Va. Code § 21-1D-5 provides that any solicitation for a public improvement contract requires each Vendor that submits a bid for the work to submit at the same time an affidavit that the Vendor has a written plan for a drug-free workplace policy. To comply with this law, Vendor must either complete the enclosed drug-free workplace affidavit and submit the same with its bid or complete a similar affidavit that fulfills all of the requirements of the applicable code. Failure to submit the signed and notarized drug-free workplace affidavit, or a similar affidavit that fully complies with the requirements of the applicable code, with the bid shall result in disqualification of Vendor's bid.
3. **AIA DOCUMENTS:** All construction contracts that will be completed in conjunction with architectural services procured under Chapter 5G of the West Virginia Code will be governed by the AIA A101-2007 and A201-2007 or the A107-2007 documents, as amended by the Supplementary Conditions for the State of West Virginia, in addition to the terms and conditions contained herein.
4. **SUBCONTRACTOR LIST SUBMISSION:** In accordance with W. Va. Code § 5-22-1, The apparent low bidder on a contract for the construction, alteration, decoration, painting or improvement of a new or existing building or structure valued at more than \$500,000.00 shall submit a list of all subcontractors who will perform more than \$25,000.00 of work on the project including labor and materials. This provision shall not apply to any other construction projects, such as highway, mine reclamation, water or sewer projects.

- c. Required Information.** The subcontractor list shall contain the following information:
- i. Bidder's name
 - ii. Name of each subcontractor
 - iii. License numbers as required by W. Va. Code § 21-11-1 et. seq.
 - iv. Notation that no subcontractors will be used if the bidder will perform the work
- d. Submission.** The completed subcontractor list shall be provided to the Purchasing Division within one business day of the opening of bids for review. Failure to submit the subcontractor list within one business day after the deadline for submitting bids shall result in disqualification of the bid.
- e. Substitution of Subcontractor.** Written approval must be obtained from the Purchasing Division before any subcontractor substitution is permitted. Substitutions are not permitted unless:
- i. The subcontractor listed in the original bid has filed for bankruptcy;
 - ii. The subcontractor in the original bid has been debarred or suspended; or
 - iii. The contractor certifies in writing that the subcontractor listed in the original bill fails, is unable, or refuses to perform his subcontract.
- 5. GREEN BUILDINGS MINIMUM ENERGY STANDARDS:** In accordance with § 22-29-4, all new building construction projects of public agencies that have not entered the schematic design phase prior to July 1, 2012, or any building construction project receiving state grant funds and appropriations, including public schools, that have not entered the schematic design phase prior to July 1, 2012, shall be designed and constructed complying with the ICC International Energy Conservation Code, adopted by the State Fire Commission, and the ANSI/ASHRAE/IESNA Standard 90.1-2007: *Provided*, That if any construction project has a commitment of federal funds to pay for a portion of such project, this provision shall only apply to the extent such standards are consistent with the federal standards.

Milam Ridge Refuse Piles

DEP16241

Contractor's Bid Sheet

Vendors Name: GREEN MOUNTAIN COMPANY

The DEP reserves the right to request additional information and supporting documentation regarding unit prices when the unit price appears to be unreasonable.

ITEM NO.	QUANTITY	UNIT	DESCRIPTION	UNIT PRICE	AMOUNT
1.1	LS	LS	MOBILIZATION & DEMOBILIZATION (LUMP SUM) (CANNOT EXCEED 10% OF TOTAL AMOUNT BID)	LS	\$ 1,000
2.1	LS	LS	CONSTRUCTION LAYOUT (LUMP SUM) (CANNOT EXCEED 5% OF TOTAL AMOUNT BID)	LS	\$ 1,000
3.1	LS	LS	QUALITY CONTROL (LUMP SUM) (CANNOT EXCEED 3% OF TOTAL AMOUNT BID)	LS	\$ 1,000
4.1	LS	LS	SITE PREPARATION (LUMP SUM) (CANNOT EXCEED 10% OF TOTAL AMOUNT BID)	LS	\$ 40,000
5.1	3,250	LF	SILT FENCE (PER LINEAR FOOT)	\$ 0.10	\$ 325
5.2	500	LF	SUPER SILT FENCE (PER LINEAR FOOT)	\$ 0.10	\$ 50
5.3	400	LF	STRAW WATTLE (PER LINEAR FOOT)	\$ 0.10	\$ 40
5.4	25	EA	STONE CHECK DAM (PER EACH)	\$ 550	\$ 13,750
5.5	1	EA	STABILIZED CONSTRUCTION ENTRANCE (PER EACH)	\$ 27,035	\$ 27,035
6.1	10	ACRE	REVEGETATION (PER PLAN VIEW ACRE)	\$ 100	\$ 1,000
7.1	1,640	LF	TYPE I GRASS LINED DITCH (PER LINEAR FOOT)	\$ 10	\$ 16,400
7.2	940	LF	TYPE II RIPRAP DITCH (PER LINEAR FOOT)	\$ 45	\$ 42,300
7.3	260	LF	TYPE III GROUTED RIPRAP DITCH (PER LINEAR FOOT)	120	31,200
7.4	70	LF	36" HDPE PIPE CULVERT (PER LINEAR FOOT)	100	7,000
7.5	2	EA	HEADWALL FOR 36" PIPE CULVERT (PER EACH)	\$ 4,000	\$ 8,000
7.6	7	EA	TYPE I LOW WATER CROSSING (PER EACH)	\$ 2,500	\$ 17,500
7.7	6	EA	TYPE II LOW WATER CROSSING (PER EACH)	\$ 2,500	\$ 15,000
7.8	100	LF	UNDERDRAIN (PER LINEAL FOOT)	\$ 60	\$ 6,000
10.1	23	EA	WET MINE SEALS (PER EACH)	\$ 5,500	\$ 126,500
10.2	1	EA	WET BAT GATE MINE SEAL (PER EACH)	\$ 8,000	\$ 8,000
10.3	2	EA	DRY MINE SEAL (PER EACH)	\$ 2,500	\$ 5,000
10.4	4	EA	DRY BAT GATE MINE SEAL (PER EACH)	\$ 8,000	\$ 32,000
10.5	960	LF	MINE SEAL CONVEYANCE PIPE (PER LINEAR FOOT)	\$ 15	\$ 14,400
10.6	10	BAG	ACID MINE DRAINAGE TREATMENT (PER 50 LB. BAG)	\$ 50	\$ 500
			TOTAL		\$ 415,000

Instructions for Completing AML Contractor Form OMB #1029-0119¹

Part A: General Information. Part A should be completed by the AML Contractor.

Part B: Legal Structure. Part B should be completed by the AML Contractor.

Part C: Certifying and updating information in the Applicant/Violator System (AVS). Part C should be completed by the AML Contractor, selecting the statement that best describes their situation.

If information is accurate, complete and up-to-date, then check the first statement and sign and date. Attach the Entity OFT printout to the OMB #1029-0119 form and submit the form and attachment to the AML Contracting Officer your business is working with.²

Upon reviewing an Entity OFT printout, if you discover the information contained in AVS is not accurate, complete and up-to-date, then check the second statement and complete Part D to provide missing or corrected information that needs reflected in AVS. Attach the Entity OFT printout to the OMB #1029-0119 form and submit the form and attachment to the AML Contracting Officer your business is working with.

If your business does not appear to have any information in AVS, then check the third statement and complete Part D. Submit the OMB #1029-0119 form to the AML Contracting Officer your business is working with.

Part D:

If current Entity OFT information for your business is incomplete, incorrect, or if you believe there is no information currently in the AVS for your business, you must complete Part D. Submit the OMB #1029-0119 form to the AML Contracting Officer your business is working with.

¹ If you need any assistance completing OMB #1029-0119, please contact the AVS Office at 800.643.9748.

² You may obtain your business' Entity OFT for certification purposes two ways. One way is to contact the AVS Office at 800.643.9748 and request the information. The second way is to access the AVS from your personal computer by visiting <https://avss.osmre.gov>. Click "Access AVS", and then Login as Guest. Place your cursor on the "Entity" Module and "Click". Type your business name in search box and press enter key. If more than one entity record appears, select your company and then "Click" on the "relationship" tab to display your Entity OFT information. Print the Entity OFT from AVS.

OMB #1029-0119
Expiration Date: 1/31/16

AML CONTRACTOR INFORMATION FORM

You must complete this form for your AML contracting officer to request an eligibility evaluation from the Office of Surface Mining to determine if you are eligible to receive an AML contract. This requirement applies to contractors and their sub-contractors and is found under OSM's regulations at 30 CFR 874.16. When possible, please type your information onto this form to reduce errors on our end. **NOTE: Signature and date this form is signed must be recent (within the last month) to be considered for a current bid**

Part A: General Information

Business Name: Green Mountain Company Tax Payer ID No.: 55-0580174
Address: 511 50th Street
City: Charleston State: WV Zip Code: 25304 Phone: (304)925-0253
Fax No.: (304)925-9230 E-mail address: gmtkl6@aol.com

Part B: Legal Structure

Corporation Sole Proprietorship Partnership LLC
 Other (please specify) _____

Part C: Certifying and updating information in the Applicant/Violator System (AVS). Select only one of the following options, follow the instructions for that option, and sign below.

I, Rodney W. Clay, have the express authority to certify that:
(print name)

- Information on the **attached** Entity Organizational Family Tree (OFT) from AVS is accurate, complete, and up-to-date. If you select this option, you **must** attach an Entity OFT from AVS to this form. Sign and date below and do not complete Part D.
- _____ Part of the information on the **attached** Entity OFT from AVS is missing or incorrect and must be updated. If you select this option, you **must** attach an Entity OFT from AVS to this form. Use Part D to provide the missing or corrected information. Sign and date below and complete Part D.
- _____ Our business currently is not listed in AVS. If you select this option, you must provide all information required in Part D. Sign and date below and complete Part D.

06/25/13

Date

Signature

President

Title

IMPORTANT! In order to certify in Part C to the accuracy of existing information in AVS, you must obtain a copy of your business' Entity OFT. To obtain an Entity OFT, contact the AVS Office, toll-free, at 800-643-9748 or from the AVS website at <https://avss.osmre.gov>.

Part D.

Contractor's Business Name: GREEN MOUNTAIN COMPANY

If the current Entity OFT information for your business is incomplete or incorrect in AVS, or if there is no information in AVS for your business, you must provide all of the following information as it applies to your business. Please make as many copies of this page as you require.

- Every officer (President, Vice President, Secretary, Treasurer, etc.);
- All Directors;
- All persons performing a function similar to a Director;
- Every person or business that owns 10% or more of the voting stock in your business;
- Every partner, if your business is a partnership;
- Every member and manager, if your business is a limited liability company; and
- Any other person(s) who has the ability to determine the manner in which the AML reclamation project is being conducted.

Name	_____	Position/Title	_____
Address	_____	Telephone #	_____
	_____	% of Ownership	_____
Begin Date:	_____	Ending Date:	_____
Name	_____	Position/Title	_____
Address	_____	Telephone #	_____
	_____	% of Ownership	_____
Begin Date:	_____	Ending Date:	_____
Name	_____	Position/Title	_____
Address	_____	Telephone #	_____
	_____	% of Ownership	_____
Begin Date:	_____	Ending Date:	_____
Name	_____	Position/Title	_____
Address	_____	Telephone #	_____
	_____	% of Ownership	_____
Begin Date:	_____	Ending Date:	_____

PAPERWORK REDUCTION STATEMENT

The Paperwork Reduction Act of 1995 (44 U.S.C. 3501) requires us to inform you that: Federal Agencies may not conduct or sponsor, and a person is not required to respond to, a collection of information unless it displays a currently valid OMB control number. This information is necessary for all successful bidders prior to the distribution of AML funds, and is required to obtain a benefit.

Public reporting burden for this form is estimated to range from 15 minutes to 1 hour, with an average of 22 minutes per response, including time for reviewing instructions, gathering and maintaining data, and completing and reviewing the form. You may direct comments regarding the burden estimate or any other aspect of this form to the Information Collection Clearance Officer, Office of Surface Mining Reclamation and Enforcement, Room 202 SIB, Constitution Ave., NW, Washington, D.C. 20240.



AVS OFT Report - 5/23/2013 9:33:04 AM

All OFT's where the selected entity is listed as an entity or related entity

Entity Selected (139758) Green Mountain Company

Parent Entity	Description	ExtDesc	Related Entity	% Ownership	Begin Date	End Date
(139758) Green Mountain Company	Vice President		(139754) David H Bowman		3/1/1993	
(139758) Green Mountain Company	Chairman of the Board		(139752) Rodney W Clay		12/1/1988	
(139758) Green Mountain Company	Director		(139752) Rodney W Clay		12/1/1988	
(139758) Green Mountain Company	President		(139752) Rodney W Clay		12/1/1985	
(139758) Green Mountain Company	Shareholder		(139752) Rodney W Clay	100%	12/1/1985	
(139758) Green Mountain Company	Treasurer		(139752) Rodney W Clay		12/1/1988	
(139758) Green Mountain Company	Secretary		(139753) Tammy J Clay		4/1/1987	

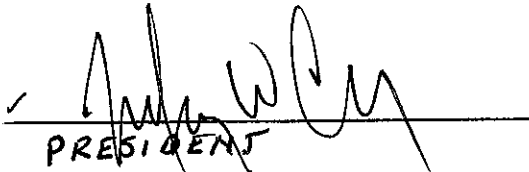
PRESIDENT

BID BOND

KNOW ALL MEN BY THESE PRESENTS, That we, the undersigned, Green Mountain Company
of 511 50th Street, Charleston WV 25304, as Principal, and Ohio Farmers Insurance Company
of One Park Circle Westfield Center OH, a corporation organized and existing under the laws of the State of Ohio
with its principal office in the City of Westfield Center, as Surety, are held and firmly bound unto the State
of West Virginia, as Obligee, in the penal sum of Five Percent (\$ 5%) for the payment of which,
well and truly to be made, we jointly and severally bind ourselves, our heirs, administrators, executors, successors and assigns.

The Condition of the above obligation is such that whereas the Principal has submitted to the Purchasing Section of the
Department of Administration a certain bid or proposal, attached hereto and made a part hereof, to enter into a contract in writing for
DEP16241, Milam Ridge Refuse Pile in Wyoming County, according to plans and specifications.

NOW THEREFORE,

- (a) If said bid shall be rejected, or
- (b) If said bid shall be accepted and the Principal shall enter into a contract in accordance with the bid or proposal attached hereto and shall furnish any other bonds and insurance required by the bid or proposal, and shall in all other respects perform the agreement created by the acceptance of said bid, then this obligation shall be null and void, otherwise this obligation shall remain in full force and effect. It is expressly understood and agreed that the liability of the Surety for any and all claims hereunder shall, in no event, exceed the penal amount of this obligation as herein stated.

The Surety, for the value received, hereby stipulates and agrees that the obligations of said Surety and its bond shall be in no way impaired or affected by any extension of the time within which the Obligee may accept such bid, and said Surety does hereby waive notice of any such extension.

IN WITNESS WHEREOF, Principal and Surety have hereunto set their hands and seals, and such of them as are corporations have caused their corporate seals to be affixed hereunto and these presents to be signed by their proper officers, this 29th day of May, 2013.

Principal Corporate Seal

Green Mountain Company
(Name of Principal)
By [Signature]
Rodney W. Clay (Must be President or Vice President)
President
(Title)

Surety Corporate Seal

Ohio Farmers Insurance Company
(Name of Surety)
[Signature]
Attorney-in-Fact
Sheila D. McCormick

IMPORTANT – Surety executing bonds must be licensed in West Virginia to transact surety insurance. Corporate seals must be affixed, and a power of attorney must be attached.

General
Power
of Attorney

POWER NO. 4751892 01

Westfield Insurance Co.
Westfield National Insurance Co.
Ohio Farmers Insurance Co.
Westfield Center, Ohio

CERTIFIED COPY

Know All Men by These Presents, That WESTFIELD INSURANCE COMPANY, WESTFIELD NATIONAL INSURANCE COMPANY and OHIO FARMERS INSURANCE COMPANY, corporations, hereinafter referred to individually as a "Company" and collectively as "Companies," duly organized and existing under the laws of the State of Ohio, and having its principal office in Westfield Center, Medina County, Ohio, do by these presents make, constitute and appoint
ROSS E. JOHNSON, H. RANDOLPH NEVILLE, PATRICK B. KEE, SHEILA D. MCCORMICK, JOINTLY OR SEVERALLY

of **CHARLESTON** and State of **WV** its true and lawful Attorney(s)-in-Fact, with full power and authority hereby conferred in its name, place and stead, to execute, acknowledge and deliver **any and all bonds, recognizances, undertakings, or other instruments or contracts of suretyship**.

LIMITATION: THIS POWER OF ATTORNEY CANNOT BE USED TO EXECUTE NOTE GUARANTEE, MORTGAGE DEFICIENCY, MORTGAGE GUARANTEE, OR BANK DEPOSITORY BONDS.

and to bind any of the Companies thereby as fully and to the same extent as if such bonds were signed by the President, sealed with the corporate seal of the applicable Company and duly attested by its Secretary, hereby ratifying and confirming all that the said Attorney(s)-in-Fact may do in the premises. Said appointment is made under and by authority of the following resolution adopted by the Board of Directors of each of the WESTFIELD INSURANCE COMPANY, WESTFIELD NATIONAL INSURANCE COMPANY and OHIO FARMERS INSURANCE COMPANY:

"Be it Resolved, that the President, any Senior Executive, any Secretary or any Fidelity & Surety Operations Executive or other Executive shall be and is hereby vested with full power and authority to appoint any one or more suitable persons as Attorney(s)-in-Fact to represent and act for and on behalf of the Company subject to the following provisions:

The Attorney-in-Fact. may be given full power and authority for and in the name of and on behalf of the Company, to execute, acknowledge and deliver, any and all bonds, recognizances, contracts, agreements of indemnity and other conditional or obligatory undertakings and any and all notices and documents canceling or terminating the Company's liability thereunder, and any such instruments so executed by any such Attorney-in-Fact shall be as binding upon the Company as if signed by the President and sealed and attested by the Corporate Secretary."

"Be it Further Resolved, that the signature of any such designated person and the seal of the Company heretofore or hereafter affixed to any power of attorney or any certificate relating thereto by facsimile, and any power of attorney or certificate bearing facsimile signatures or facsimile seal shall be valid and binding upon the Company with respect to any bond or undertaking to which it is attached." (Each adopted at a meeting held on February 8, 2000).

In Witness Whereof, WESTFIELD INSURANCE COMPANY, WESTFIELD NATIONAL INSURANCE COMPANY and OHIO FARMERS INSURANCE COMPANY have caused these presents to be signed by their **National Surety Leader and Senior Executive** and their corporate seals to be hereto affixed this **25th** day of **AUGUST** A.D., **2008**.

Corporate
Seals
Affixed



WESTFIELD INSURANCE COMPANY
WESTFIELD NATIONAL INSURANCE COMPANY
OHIO FARMERS INSURANCE COMPANY

By: *Dennis P. Baus*
Dennis P. Baus, National Surety Leader and Senior Executive

State of Ohio
County of Medina ss.:

On this **25th** day of **AUGUST** A.D., **2008**, before me personally came **Dennis P. Baus** to me known, who, being by me duly sworn, did depose and say, that he resides in **Wooster, Ohio**; that he is **National Surety Leader and Senior Executive** of WESTFIELD INSURANCE COMPANY, WESTFIELD NATIONAL INSURANCE COMPANY and OHIO FARMERS INSURANCE COMPANY, the companies described in and which executed the above instrument; that he knows the seals of said Companies; that the seals affixed to said instrument are such corporate seals; that they were so affixed by order of the Boards of Directors of said Companies; and that he signed his name thereto by like order.

Notarial
Seal
Affixed



William J. Kahelin
William J. Kahelin, Attorney at Law, Notary Public
My Commission Does Not Expire (Sec. 147.03 Ohio Revised Code)

State of Ohio
County of Medina ss.:

I, **Frank A. Carrino**, Secretary of WESTFIELD INSURANCE COMPANY, WESTFIELD NATIONAL INSURANCE COMPANY and OHIO FARMERS INSURANCE COMPANY, do hereby certify that the above and foregoing is a true and correct copy of a Power of Attorney, executed by said Companies, which is still in full force and effect; and furthermore, the resolutions of the Boards of Directors, set out in the Power of Attorney are in full force and effect.

In Witness Whereof, I have hereunto set my hand and affixed the seals of said Companies at Westfield Center, Ohio, this **29th** day of **May**, A.D., **2013**.



Frank A. Carrino
Frank A. Carrino, Secretary



State of West Virginia

PURCHASING DIVISION

Construction Bid Submission Review Form

This list has been provided for informational purposes only and is not to be construed as a complete list of request for quotation or bidding requirements for any individual construction project. This list does not and cannot include every item, mistake or oversight that could cause a contractor's bid to be disqualified. Rather, this list is intended to draw attention to some of the most common problems that the Purchasing Division encounters in the bidding process for construction projects. All potential bidders must read the request for quotation, all additional documents, and all instructions relating thereto ("Bid Documents") in their entirety to identify the actual request for quotation and bidding requirements. Failure to read the Bid Documents in their entirety and comply with the stated requirements contained therein may result in bid disqualification.

Errors That Shall Be Reason for Immediate Bid Disqualification

1. Failure to attend a mandatory pre-bid meeting
2. Failure to sign the bid
3. Failure to supply West Virginia contractor's license # on bid
4. Failure to supply a signed drug free workplace affidavit with the bid
5. Failure to supply a valid bid bond or other surety approved by the State of West Virginia
6. Failure to meet any mandatory requirement of the RFQ
7. Failure to acknowledge receipt of Addenda (only if stipulated as mandatory)
8. Failure to submit bid prior to the bid opening date and time
9. Federal debarment
10. State of West Virginia debarment or suspension

Errors that May Be Reason for Bid Disqualification Before Contract Award

1. Uncontested debt to the State exceeding \$1,000.00 (must be cured prior to award)
2. Workers' Compensation or Unemployment Compensation delinquency (must be cured prior to award)
3. Not registered as a vendor with the State (must be cured prior to award)
4. Failure to obtain required bonds and/or insurance
5. Failure to provide the sub-contractor listing within 1 business day of bid opening.
6. Failure to use the provided RFQ form (only if stipulated as mandatory).



State of West Virginia
DRUG FREE WORKPLACE CONFORMANCE AFIDAVIT
West Virginia Code §21-1D-5

STATE OF West Virginia

COUNTY OF Kanawha, TO-WIT:

I, Rodney W. Clay, after being first duly sworn, depose and state as follows:

- 1. I am an employee of Green Mountain Company and,
(Company Name)
- 2. I do hereby attest that Green Mountain Company
(Company Name)

maintains a valid written drug free workplace policy and that such policy is in compliance with **West Virginia Code** §21-1D-5.

The above statements are sworn to under the penalty of perjury.

Green Mountain Company
(Company name)

By: [Signature]
Title: President

Date: 06/25/13

Taken, subscribed and sworn to before me this 25th day of June, 2013

By Commission expires April 6, 2019

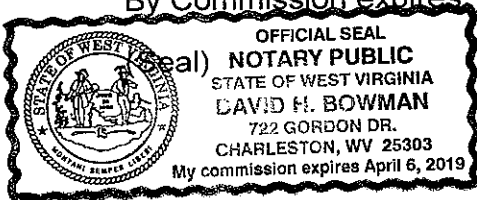

[Signature]
(Notary Public)

THIS AFFIDAVIT MUST BE SUBMITTED WITH THE BID IN ORDER TO COMPLY WITH WV CODE PROVISIONS. FAILURE TO INCLUDE THE AFFIDAVIT WITH THE BID SHALL RESULT IN DISQUALIFICATION OF THE BID.

RFQ No. DEP 16241

STATE OF WEST VIRGINIA
Purchasing Division
PURCHASING AFFIDAVIT

MANDATE: Under W. Va. Code §5A-3-10a, no contract or renewal of any contract may be awarded by the state or any of its political subdivisions to any vendor or prospective vendor when the vendor or prospective vendor or a related party to the vendor or prospective vendor is a debtor and: (1) the debt owed is an amount greater than one thousand dollars in the aggregate; or (2) the debtor is in employer default.

EXCEPTION: The prohibition listed above does not apply where a vendor has contested any tax administered pursuant to chapter eleven of the W. Va. Code, workers' compensation premium, permit fee or environmental fee or assessment and the matter has not become final or where the vendor has entered into a payment plan or agreement and the vendor is not in default of any of the provisions of such plan or agreement.

DEFINITIONS:

"Debt" means any assessment, premium, penalty, fine, tax or other amount of money owed to the state or any of its political subdivisions because of a judgment, fine, permit violation, license assessment, defaulted workers' compensation premium, penalty or other assessment presently delinquent or due and required to be paid to the state or any of its political subdivisions, including any interest or additional penalties accrued thereon.

"Employer default" means having an outstanding balance or liability to the old fund or to the uninsured employers' fund or being in policy default, as defined in W. Va. Code § 23-2c-2, failure to maintain mandatory workers' compensation coverage, or failure to fully meet its obligations as a workers' compensation self-insured employer. An employer is not in employer default if it has entered into a repayment agreement with the Insurance Commissioner and remains in compliance with the obligations under the repayment agreement.

"Related party" means a party, whether an individual, corporation, partnership, association, limited liability company or any other form or business association or other entity whatsoever, related to any vendor by blood, marriage, ownership or contract through which the party has a relationship of ownership or other interest with the vendor so that the party will actually or by effect receive or control a portion of the benefit, profit or other consideration from performance of a vendor contract with the party receiving an amount that meets or exceeds five percent of the total contract amount.

AFFIRMATION: By signing this form, the vendor's authorized signer affirms and acknowledges under penalty of law for false swearing (W. Va. Code §61-5-3) that neither vendor nor any related party owe a debt as defined above and that neither vendor nor any related party are in employer default as defined above, unless the debt or employer default is permitted under the exception above.

WITNESS THE FOLLOWING SIGNATURE:

Vendor's Name: Green Mountain Company

Authorized Signature: [Signature], President Date: 06/25/13

State of West Virginia

County of Kanawha, to-wit:

Taken, subscribed, and sworn to before me this 25th day of June, 2013,

My Commission expires April 06th, 2019.

AFFIX SEAL HERE

NOTARY PUBLIC David H. Bowman

Purchasing Affidavit (Revised 07/01/2012)

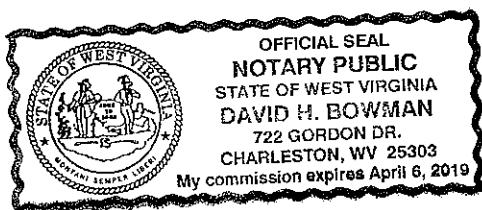

CERTIFICATION AND SIGNATURE PAGE

By signing below, I certify that I have reviewed this Solicitation in its entirety; understand the requirements, terms and conditions, and other information contained herein; that I am submitting this bid or proposal for review and consideration; that I am authorized by the bidder to execute this bid or any documents related thereto on bidder's behalf; that I am authorized to bind the bidder in a contractual relationship; and that to the best of my knowledge, the bidder has properly registered with any State agency that may require registration.

GREEN MOUNTAIN COMPANY
(Company)

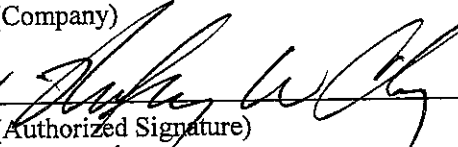
(Authorized Signature)

✓ Rodney W. Clay, PRESIDENT
(Representative Name, Title)

304-925-0253 304-925-9230
(Phone Number) (Fax Number)

06/25/13
(Date)

ADDENDUM ACKNOWLEDGEMENT FORM
SOLICITATION NO.: DEP16241

Instructions: Please acknowledge receipt of all addenda issued with this solicitation by completing this addendum acknowledgment form. Check the box next to each addendum received and sign below. Failure to acknowledge addenda may result in bid disqualification.

Acknowledgment: I hereby acknowledge receipt of the following addenda and have made the necessary revisions to my proposal, plans and/or specification, etc.

Addendum Numbers Received:

(Check the box next to each addendum received)

- | | |
|--|--|
| <input checked="" type="checkbox"/> Addendum No. 1 | <input type="checkbox"/> Addendum No. 6 |
| <input type="checkbox"/> Addendum No. 2 | <input type="checkbox"/> Addendum No. 7 |
| <input type="checkbox"/> Addendum No. 3 | <input type="checkbox"/> Addendum No. 8 |
| <input type="checkbox"/> Addendum No. 4 | <input type="checkbox"/> Addendum No. 9 |
| <input type="checkbox"/> Addendum No. 5 | <input type="checkbox"/> Addendum No. 10 |

I understand that failure to confirm the receipt of addenda may be cause for rejection of this bid. I further understand that any verbal representation made or assumed to be made during any oral discussion held between Vendor's representatives and any state personnel is not binding. Only the information issued in writing and added to the specifications by an official addendum is binding.

GREEN MOUNTAIN COMPANY
Company

[Signature], PRESIDENT
Authorized Signature

06/25/13
Date

NOTE: This addendum acknowledgment should be submitted with the bid to expedite document processing.



State of West Virginia
 Department of Administration
 Purchasing Division
 2019 Washington Street East
 Post Office Box 50130
 Charleston, WV 25305-0130

Solicitation

NUMBER
DEP16241

PAGE
1

ADDRESS CORRESPONDENCE TO ATTENTION OF
FRANK WHITTAKER
304-558-2316

*709045227 304-925-0253

GREEN MOUNTAIN COMPANY
 511 50TH ST

CHARLESTON WV 25304

VENDOR

SHIP TO

ENVIRONMENTAL PROTECTION
 DEPARTMENT OF
 OFFICE OF AML&R
 601 57TH STREET SE
 CHARLESTON, WV
 25304 304-926-0499

DATE PRINTED
06/18/2013

BID OPENING DATE: 06/25/2013

BID OPENING TIME 1:30PM

LINE	QUANTITY	UOP	CAT NO	ITEM NUMBER	UNIT PRICE	AMOUNT
				ADDENDUM NO. 1		
				ADDENDUM IS ISSUED:		
				1. TO PROVIDE ANSWER TO QUESTIONS REGARDING THE SOLICITATION.		
				2. TO PROVIDE REVISED DRAWINGS. DETAILED DRAWINGS ARE ATTACHED.		
				3. TO PROVIDE VENDORS A COPY OF THE MANDATORY PRE-BID MEETING SIGN-IN SHEET.		
				4. TO PROVIDE ADDENDUM ACKNOWLEDGEMENT. THIS DOCUMENT SHOULD BE SIGNED AND RETURNED WITH YOUR BID. FAILURE TO SIGN AND RETURN MAY RESULT IN THE DISQUALIFICATION OF YOUR BID.		
				END OF ADDENDUM NO. 1		

SIGNATURE	TELEPHONE 304-925-0253	DATE 06/25/13
TITLE PRESIDENT	FERN 55-0580174	ADDRESS CHANGES TO BE NOTED ABOVE

WHEN RESPONDING TO SOLICITATION, INSERT NAME AND ADDRESS IN SPACE ABOVE LABELED 'VENDOR'



State of West Virginia
 Department of Administration
 Purchasing Division
 2019 Washington Street East
 Post Office Box 50130
 Charleston, WV 25305-0130

Solicitation

NUMBER
 DEP16241

PAGE
 2

ADDRESS CORRESPONDENCE TO ATTENTION OF
 FRANK WHITTAKER
 304-558-2316

VENDOR

*709045227 304-925-0253
 GREEN MOUNTAIN COMPANY
 511 50TH ST
 CHARLESTON WV 25304

SHIP TO

ENVIRONMENTAL PROTECTION
 DEPARTMENT OF
 OFFICE OF AML&R
 601 57TH STREET SE
 CHARLESTON, WV
 25304 304-926-0499

DATE PRINTED
 06/18/2013

BID OPENING DATE: 06/25/2013 BID OPENING TIME 1:30PM

LINE	QUANTITY	UOP	CAT NO	ITEM NUMBER	UNIT PRICE	AMOUNT
0001	1	JB		962-73		
RECLAMATION: RESTORATION OF LAND & OTHER PROPERTIES						
***** THIS IS THE END OF RFQ DEP16241 ***** TOTAL:						\$ 41,500.00

SIGNATURE *[Signature]* TELEPHONE 304-925-0253 DATE 06/25/13
 TITLE PRESIDENT FEIN 55-0580174 ADDRESS CHANGES TO BE NOTED ABOVE

WHEN RESPONDING TO SOLICITATION, INSERT NAME AND ADDRESS IN SPACE ABOVE LABELED 'VENDOR'

SOLICITATION NUMBER: DEP16241

Addendum Number: 1

The purpose of this addendum is to modify the solicitation identified as ("Solicitation") to reflect the change(s) identified and described below.

Applicable Addendum Category:

- Modify bid opening date and time
- Modify specifications of product or service being sought
- Attachment of vendor questions and responses
- Attachment of pre-bid sign-in sheet
- Correction of error
- Other

Description of Modification to Solicitation:

1. To provide answer to questions regarding the above solicitation.
2. To provide revised detailed drawings.
3. To provide a copy of the Mandatory pre-bid sign-in sheets.
4. To provide Addendum Acknowledgement.

Additional Documentation: Documentation related to this Addendum (if any) has been included herewith as Attachment A and is specifically incorporated herein by reference.

Terms and Conditions:

1. All provisions of the Solicitation and other addenda not modified herein shall remain in full force and effect.
2. Vendor should acknowledge receipt of all addenda issued for this Solicitation by completing an Addendum Acknowledgment, a copy of which is included herewith. Failure to acknowledge addenda may result in bid disqualification. The addendum acknowledgement should be submitted with the bid to expedite document processing.

ATTACHMENT A

Milam Ridge Refuse Pile**Addendum #1****DEP16241**

Item 1: The contractor will have 180 days from the date of the Notice to Proceed to complete construction activities on the project. The \$ 250 per day liquidated damage clause will be in effect after the 180 days. However, the total performance period will be 365 days from the date of the Notice to Proceed for invoicing purposes.

Item 2: The Dry Bat Gate detail on Sheet D-3 has been revised to exclude references to foam sealant. A revised detail has been attached.

Item 3: The mine seal typical on Sheet D-2 has been revised to clarify the intent and limits of the backfill. A revised detail has been attached.

Item 4: Sheets D-2 and D-3 make reference to various size bat gate culverts. The bat gates used throughout the project will be 36 inch HDPE pipes.

Item 5: All rock riprap used throughout the project shall consist of locally available, commercially purchased, or on-site durable stone meeting the following requirements. The rock riprap shall have a maximum weighted loss of thirty percent when subjected to five (5) cycles of the Sodium Sulfate Soundness Test, 30% requirement – ASTM C88 (ASTM C88-99a Standard Test Method for Soundness of Aggregates by Use of Sodium Sulfate or Magnesium Sulfate), as modified by the American Association of State Highway and Transportation Officials (AASHTO) T-104. A certification on sodium sulfate soundness test shall be submitted to the WVDEP prior to delivery and/or use.

Item 6: A separate line item on the bid sheet for maintenance stone has not been included. Maintenance stone is considered incidental to the project and should be included as part of item 4.1 "Site Preparation", on the Bid Sheet.

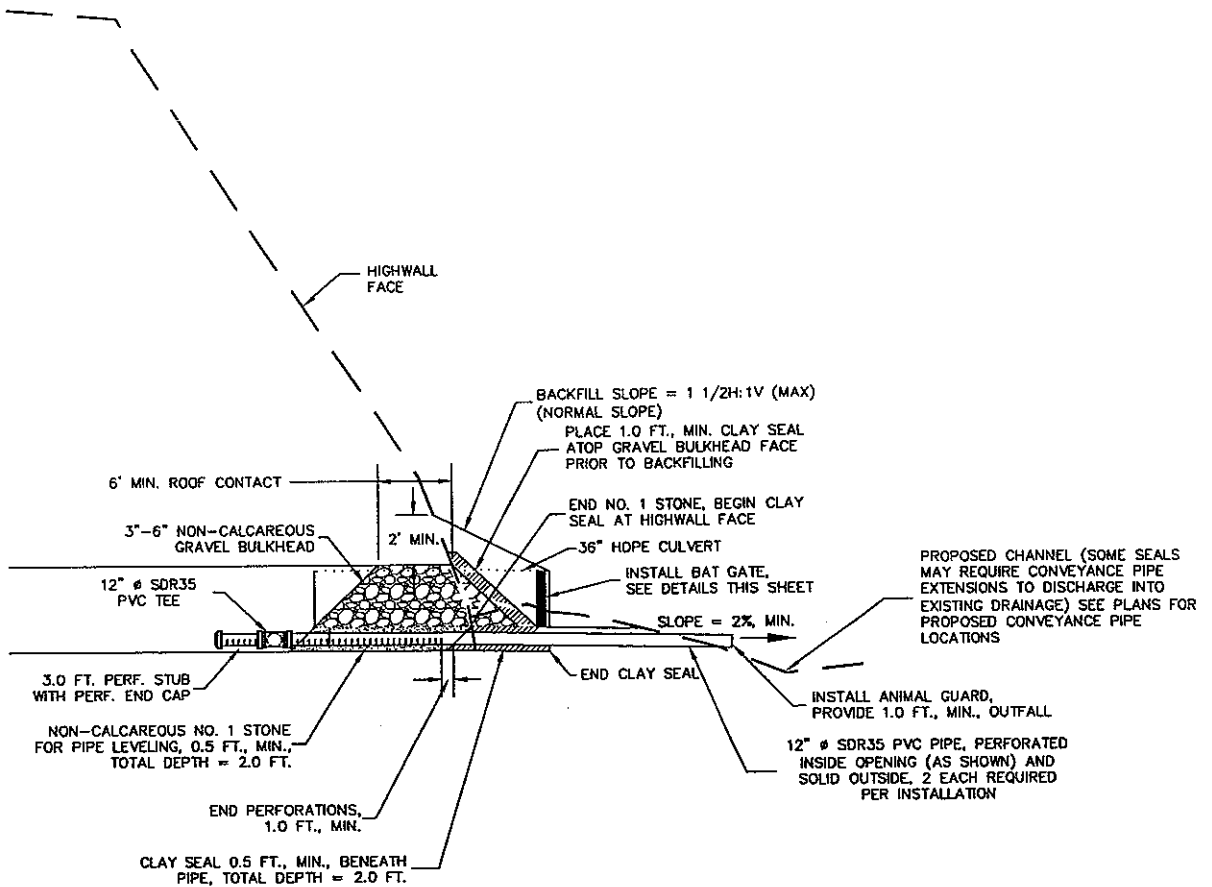

TYPICAL SECTION

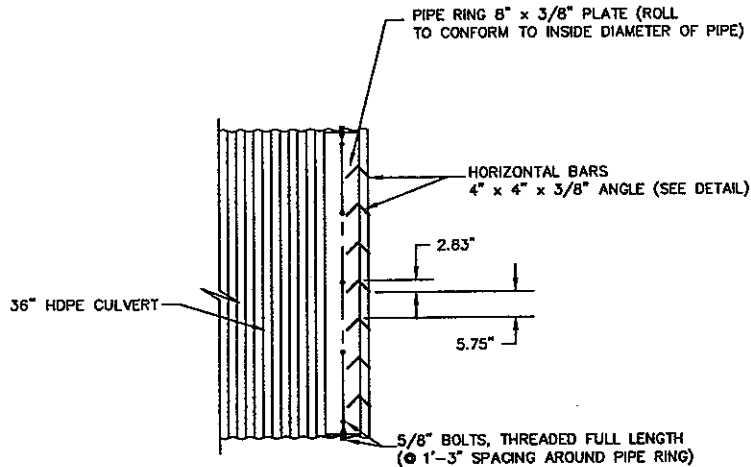

PIPE RING SECTION (ALTERNATE)



5088 Washington Street, West
Charleston, West Virginia 25313
Phone: 304-776-7473
Fax: 304-776-6426
www.elrobinsonengineering.com

WET BAT GATE MINE
SEAL



MILAM RIDGE REFUSE PILE
WYOMING COUNTY
WEST VIRGINIA

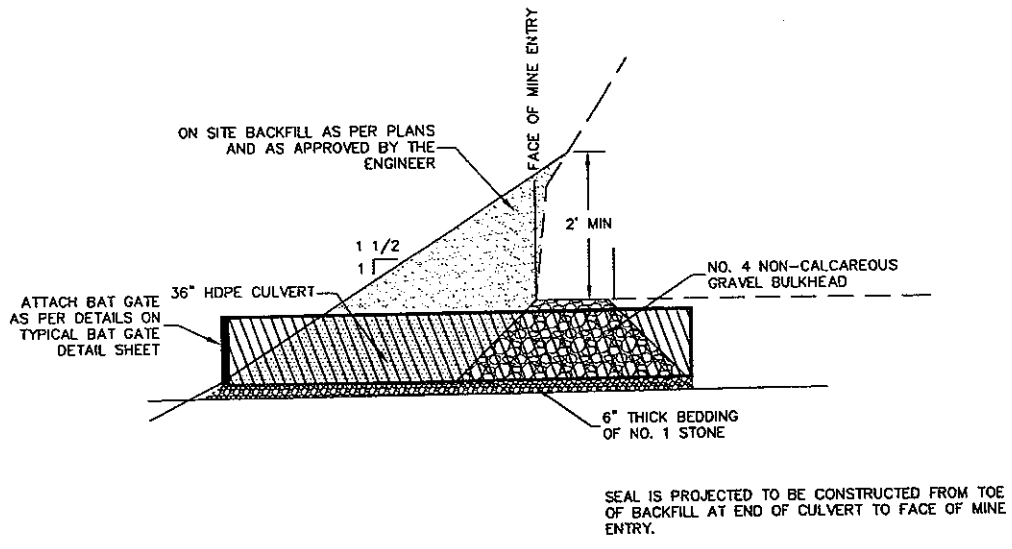

DRY BAT GATE PROFILE

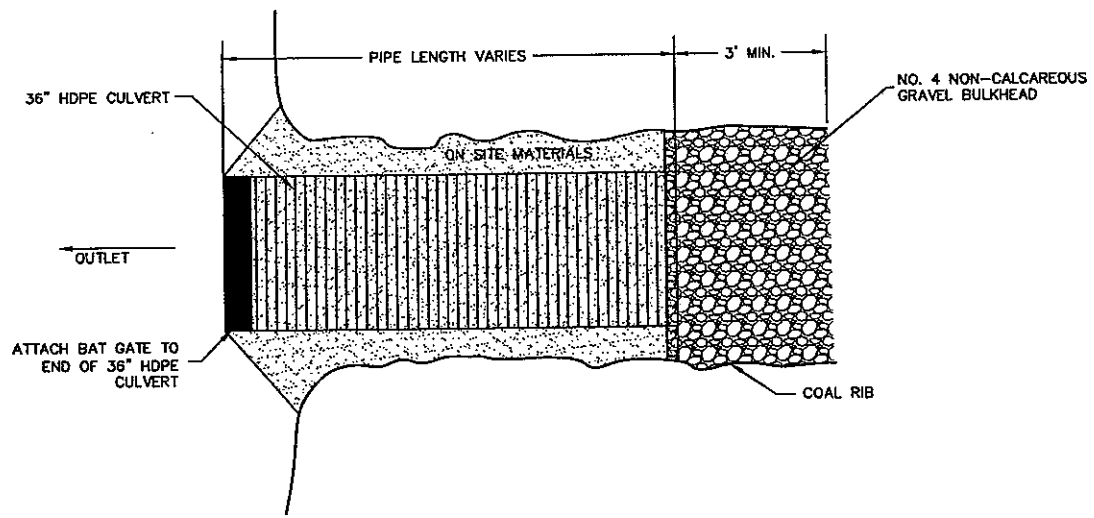

DRY BAT GATE PLAN DETAIL

EL. ROBINSON ENGINEERING
 5088 Washington Street, West
 Charleston, West Virginia 25313
 Phone: 304-776-7473
 Fax: 304-776-6426
 www.elrobinsonengineering.com

DRY BAT GATE MINE SEAL

West Virginia
 dep
 MILAM RIDGE REFUSE PILE
 WYOMING COUNTY
 WEST VIRGINIA

SIGN IN SHEET

Page 1 of 3Request for ^{Quote} Proposal No. DEP16241Date 06-06-13Milam Ridge Refuse Pile

*PLEASE BE SURE TO PRINT LEGIBLY – IF POSSIBLE, LEAVE A BUSINESS CARD

FIRM & REPRESENTATIVE NAME	MAILING ADDRESS	TELEPHONE & FAX NUMBERS
Company: <u>Hunbar Excavating LLC</u>	<u>HC 73 Box 165</u>	PHONE <u>304-923-3920</u>
Rep: <u>Brett K. Harvey</u>	<u>Pence Springs WV 24962</u>	TOLL FREE
Email Address: <u>bogieharvey@gmail.com</u>		FAX <u>304-466-0846</u>
Company: <u>Carpenter Reclamation</u>	<u>PO Box 13615</u>	PHONE <u>304-984-1115</u>
Rep: <u>Randy Carpenter</u>	<u>Sissonville, WV</u>	TOLL FREE
Email Address: <u>Rcarpen103@aol.com</u>	<u>25360</u>	FAX <u>984-2770</u>
Company: <u>Pineville Paving & Excavating Inc.</u>	<u>P.O. Box 1290</u>	PHONE <u>304-732-8303</u>
Rep: <u>Kevin B. Bradford</u>	<u>Pineville WV 24874</u>	TOLL FREE
Email Address: <u>Kevin.Bradford@AOL.com</u>		FAX <u>304-732-7855</u>
Company: <u>Aspen Corporation</u>	<u>2400 Ritter Drive</u>	PHONE <u>304-887-0108</u>
Rep: <u>Richard Koger II</u>	<u>Daniels WV 25832</u>	TOLL FREE
Email Address: <u>rkoger@aspen-golf.com</u>		FAX <u>304-763-4591</u>
Company: <u>Breakaway Inc</u>	<u>Old Turnpike Rd 1075</u>	PHONE <u>304-765-5317</u>
Rep: <u>Brian Hoard</u>	<u>Sutton WV 26601</u>	TOLL FREE
Email Address:		FAX

SIGN IN SHEET

Page 2 of 3Request for ^{Quote} Proposat No. DEP16241Date 06-06-13Milam Ridge Refuse Pile

*PLEASE BE SURE TO PRINT LEGIBLY – IF POSSIBLE, LEAVE A BUSINESS CARD

FIRM & REPRESENTATIVE NAME	MAILING ADDRESS	TELEPHONE & FAX NUMBERS
Company: <u>GREEN MOUNTAIN WASTE, INC.</u>	<u>511 50th ST</u>	PHONE <u>304-925-0253</u>
Rep: <u>DAVID H. BOWMAN</u>	<u>Charleston WV 25304</u>	TOLL FREE
Email Address: <u>DHB722@koho.com</u>		FAX <u>304-925-9250</u>
Company: <u>EASTERN ARROW</u>	<u>PO BOX 4108</u>	PHONE <u>304-414-0255</u>
Rep: <u>Ann Wardwell</u>	<u>CHARLESTON WV</u>	TOLL FREE
Email Address: <u>easternarrow@hotmail.com</u>	<u>25361</u>	FAX <u>0256</u>
Company: <u>BAINES EXC. INC.</u>	<u>P.O. BOX 13784</u>	PHONE <u>304-984-1725</u>
Rep: <u>ROBERT L. BAINES</u>	<u>Sissonville</u>	TOLL FREE
Email Address: <u>BAINES EXC (A) AOL.COM</u>	<u>WV 25360</u>	FAX <u>304-984-0074</u>
Company: <u>EAGLE EXCAVATION INC.</u>	<u>P.O. BOX 218</u>	PHONE <u>(304) 372-4378</u>
Rep: <u>GEORGE FRESHOUR</u>	<u>KENN WV 25248</u>	TOLL FREE
Email Address: _____		FAX <u>(304) 372-4378</u>
Company: <u>ALL-CON, LLC</u>	<u>124 PHILPOT LANE</u>	PHONE <u>3047310190</u>
Rep: <u>DAVID IRLE</u>	<u>BEAVER WV 25813</u>	TOLL FREE
Email Address: <u>DIRLE CACI-WV.COM</u>		FAX <u>304 255 4232</u>

SIGN IN SHEET

Request for ^{Quote} Proposal No. DEP16241

Date 06-06-13

Milam Ridge Refuse Pile

***PLEASE BE SURE TO PRINT LEGIBLY – IF POSSIBLE, LEAVE A BUSINESS CARD**

FIRM & REPRESENTATIVE NAME

MAILING ADDRESS

TELEPHONE & FAX NUMBERS

Company: <u>5 Star Contracting Inc</u>	PHONE <u>304-785-6713</u>
Rep: <u>Charlie Horn</u>	TOLL FREE
Email Address:	FAX <u>304-393-1524</u>
Company: <u>McCoy Construction</u>	PHONE <u>304-736-3582</u>
Rep: <u>Charlie Horn</u>	TOLL FREE
Email Address:	FAX
Company:	PHONE
Rep:	TOLL FREE
Email Address:	FAX
Company:	PHONE
Rep:	TOLL FREE
Email Address:	FAX
Company:	PHONE
Rep:	TOLL FREE
Email Address:	FAX

ADDENDUM ACKNOWLEDGEMENT FORM
SOLICITATION NO.: DEP16241

Instructions: Please acknowledge receipt of all addenda issued with this solicitation by completing this addendum acknowledgment form. Check the box next to each addendum received and sign below. Failure to acknowledge addenda may result in bid disqualification.

Acknowledgment: I hereby acknowledge receipt of the following addenda and have made the necessary revisions to my proposal, plans and/or specification, etc.

Addendum Numbers Received:

(Check the box next to each addendum received)

- | | |
|--|--|
| <input checked="" type="checkbox"/> Addendum No. 1 | <input type="checkbox"/> Addendum No. 6 |
| <input type="checkbox"/> Addendum No. 2 | <input type="checkbox"/> Addendum No. 7 |
| <input type="checkbox"/> Addendum No. 3 | <input type="checkbox"/> Addendum No. 8 |
| <input type="checkbox"/> Addendum No. 4 | <input type="checkbox"/> Addendum No. 9 |
| <input type="checkbox"/> Addendum No. 5 | <input type="checkbox"/> Addendum No. 10 |

I understand that failure to confirm the receipt of addenda may be cause for rejection of this bid. I further understand that any verbal representation made or assumed to be made during any oral discussion held between Vendor's representatives and any state personnel is not binding. Only the information issued in writing and added to the specifications by an official addendum is binding.

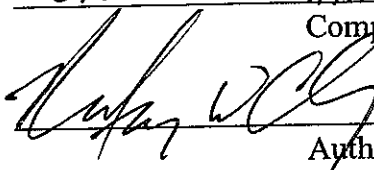
GREEN MOUNTAIN COMPANY
 Company

 Authorized Signature, PRESIDENT
06/25/13
 Date

NOTE: This addendum acknowledgment should be submitted with the bid to expedite document processing.
 Revised 6/8/2012