



State of West Virginia  
 Department of Administration  
 Purchasing Division  
 2019 Washington Street East  
 Post Office Box 50130  
 Charleston, WV 25305-0130

**Solicitation**

NUMBER
AGR1332

PAGE
1

ADDRESS CORRESPONDENCE TO ATTENTION OF:
GUY NISBET
304-558-8802

RFQ COPY  
 TYPE NAME/ADDRESS HERE

**VENDOR**

Danhill Construction Company  
 PO Box 685  
 Gauley Bridge, WV 25085

**SHIP TO**

DEPARTMENT OF AGRICULTURE  
 LAND SECTION/HUTTONSVILLE FARM  
 P.O. BOX 37  
 ROUTE 250 SOUTH  
 HUTTONSVILLE, WV  
 26273 304-558-2222

DATE PRINTED
05/07/2013

BID OPENING DATE: 06/13/2013 BID OPENING TIME 1:30PM

LINE	QUANTITY	UOP	CAT NO.	ITEM NUMBER	UNIT PRICE	AMOUNT
0001	1	LS		968-20		\$348,000.00
POST FRAME OFFICE AND SHOP BUILDING						
REQUEST FOR SOLICITATION (RFQ)						
THE WEST VIRGINIA STATE PURCHASING DIVISION FOR THE AGENCY, THE WEST VIRGINIA DEPARTMENT OF AGRICULTURE (WVAGR) IS SOLICITING BIDS TO PROVIDE ALL LABOR AND MATERIALS FOR THE CONSTRUCTION OF A "POST AND FRAME" OFFICE AND SHOP BUILDING AT THE WEST VIRGINIA DEPT. OF AGRICULTURE FARM, HUTTONSVILLE, WV. PER THE ATTACHED SPECIFICATIONS.						
***** THIS IS THE END OF RFQ AGR1332 ***** TOTAL:						\$ 348,000.00
						06/13/13 10:38:06 AM West Virginia Purchasing Division

SIGNATURE	<i>Robert D. Hill</i>	TELEPHONE	(304)632-1600	DATE	6-13-2013
TITLE	PRESIDENT	FEIN	55-0648251	ADDRESS CHANGES TO BE NOTED ABOVE	

WHEN RESPONDING TO SOLICITATION, INSERT NAME AND ADDRESS IN SPACE ABOVE LABELED 'VENDOR'

**INSTRUCTIONS TO VENDORS SUBMITTING BIDS**

1. **REVIEW DOCUMENTS THOROUGHLY:** The attached documents contain a solicitation for bids. Please read these instructions and all documents attached in their entirety. These instructions provide critical information about requirements that if overlooked could lead to disqualification of a Vendor's bid. All bids must be submitted in accordance with the provisions contained in these instructions and the Solicitation. Failure to do so may result in disqualification of Vendor's bid.
2. **MANDATORY TERMS:** The Solicitation may contain mandatory provisions identified by the use of the words "must," "will," and "shall." Failure to comply with a mandatory term in the Solicitation will result in bid disqualification.
3. **PREBID MEETING:** The item identified below shall apply to this Solicitation.

A pre-bid meeting will not be held prior to bid opening.

A **NON-MANDATORY PRE-BID** meeting will be held at the following place and time:

<p> </p>
----------

A **MANDATORY PRE-BID** meeting will be held at the following place and time:

<p>WV. Department of Agriculture/ Huttonsville Farm Route 250 South Huttonsville, WV. 26273</p> <p>May 21, 2013 at 10:00 AM. EST.</p>
---

All Vendors submitting a bid must attend the mandatory pre-bid meeting. Failure to attend the mandatory pre-bid meeting shall result in disqualification of the Vendor's bid. No one person attending the pre-bid meeting may represent more than one Vendor.

An attendance sheet provided at the pre-bid meeting shall serve as the official document verifying attendance. The State will not accept any other form of proof or documentation to verify attendance. Any person attending the pre-bid meeting on behalf of a Vendor must list on the attendance sheet his or her name and the name of the Vendor he or she is representing. Additionally, the person attending the pre-bid meeting should include the Vendor's E-Mail address, phone number, and Fax number on the attendance sheet. It is the Vendor's responsibility to locate the attendance sheet and provide the required

information. Failure to complete the attendance sheet as required may result in disqualification of Vendor's bid.

All Vendors should arrive prior to the starting time for the pre-bid. Vendors who arrive after the starting time but prior to the end of the pre-bid will be permitted to sign in, but are charged with knowing all matters discussed at the pre-bid.

Questions submitted at least five business days prior to a scheduled pre-bid will be discussed at the pre-bid meeting if possible. Any discussions or answers to questions at the pre-bid meeting are preliminary in nature and are non-binding. Official and binding answers to questions will be published in a written addendum to the Solicitation prior to bid opening.

4. **VENDOR QUESTION DEADLINE:** Vendors may submit questions relating to this Solicitation to the Purchasing Division. Questions must be submitted in writing. All questions must be submitted on or before the date listed below and to the address listed below in order to be considered. A written response will be published in a Solicitation addendum if a response is possible and appropriate. Non-written discussions, conversations, or questions and answers regarding this Solicitation are preliminary in nature and are non-binding.

Question Submission Deadline:

May 28, 2013 at 2:00 PM. EST.

Submit Questions to:

Guy Nisbet, Senior Buyer

2019 Washington Street, East

P.O. Box 50130

Charleston, WV 25305

Fax: 304.558.3970

Email: Guy.L.Nisbet@WV.Gov

5. **VERBAL COMMUNICATION:** Any verbal communication between the Vendor and any State personnel is not binding, including that made at the mandatory pre-bid conference. Only information issued in writing and added to the Solicitation by an official written addendum by the Purchasing Division is binding.
6. **BID SUBMISSION:** All bids must be signed and delivered by the Vendor to the Purchasing Division at the address listed below on or before the date and time of the bid opening. Any bid received by the Purchasing Division staff is considered to be in the possession of the Purchasing Division and will not be returned for any reason. The bid delivery address is:

Department of Administration, Purchasing Division  
 2019 Washington Street East  
 P.O. Box 50130,  
 Charleston, WV 25305-0130

The bid should contain the information listed below on the face of the envelope or the bid may not be considered:

SEALED BID

BUYER: \_\_\_\_\_

SOLICITATION NO.: \_\_\_\_\_

BID OPENING DATE: \_\_\_\_\_

BID OPENING TIME: \_\_\_\_\_

FAX NUMBER: \_\_\_\_\_

In the event that Vendor is responding to a request for proposal, the Vendor shall submit one original technical and one original cost proposal plus  convenience copies of each to the Purchasing Division at the address shown above. Additionally, the Vendor should identify the bid type as either a technical or cost proposal on the face of each bid envelope submitted in response to a request for proposal as follows:

BID TYPE:     Technical  
                    Cost

7. **BID OPENING:** Bids submitted in response to this Solicitation will be opened at the location identified below on the date and time listed below. Delivery of a bid after the bid opening date and time will result in bid disqualification. For purposes of this Solicitation, a bid is considered delivered when time stamped by the official Purchasing Division time clock.

Bid Opening Date and Time:

June 13, 2013 at 1:30 PM. EST.

Bid Opening Location:

Department of Administration, Purchasing Division  
 2019 Washington Street East  
 P.O. Box 50130,  
 Charleston, WV 25305-0130

8. **ADDENDUM ACKNOWLEDGEMENT:** Changes or revisions to this Solicitation will be made by an official written addendum issued by the Purchasing Division. Vendor should acknowledge receipt of all addenda issued with this Solicitation by completing an Addendum Acknowledgment Form, a copy of which is included herewith. Failure to acknowledge addenda may result in bid disqualification. The addendum acknowledgement should be submitted with the bid to expedite document processing.
9. **BID FORMATTING:** Vendor should type or electronically enter the information onto its bid to prevent errors in the evaluation. Failure to type or electronically enter the information may result in bid disqualification.



**GENERAL TERMS AND CONDITIONS:**

1. **CONTRACTUAL AGREEMENT:** Issuance of a Purchase Order signed by the Purchasing Division Director, or his designee, and approved as to form by the Attorney General's office constitutes acceptance of this Contract made by and between the State of West Virginia and the Vendor. Vendor's signature on its bid signifies Vendor's agreement to be bound by and accept the terms and conditions contained in this Contract.
  
2. **DEFINITIONS:** As used in this Solicitation / Contract, the following terms shall have the meanings attributed to them below. Additional definitions may be found in the specifications included with this Solicitation / Contract.
  - 2.1 "Agency" or "Agencies" means the agency, board, commission, or other entity of the State of West Virginia that is identified on the first page of the Solicitation or any other public entity seeking to procure goods or services under this Contract.
  - 2.2 "Contract" means the binding agreement that is entered into between the State and the Vendor to provide the goods and services requested in the Solicitation.
  - 2.3 "Director" means the Director of the West Virginia Department of Administration, Purchasing Division.
  - 2.4 "Purchasing Division" means the West Virginia Department of Administration, Purchasing Division.
  - 2.5 "Purchase Order" means the document signed by the Agency and the Purchasing Division, and approved as to form by the Attorney General, that identifies the Vendor as the successful bidder and Contract holder.
  - 2.6 "Solicitation" means the official solicitation published by the Purchasing Division and identified by number on the first page thereof.
  - 2.7 "State" means the State of West Virginia and/or any of its agencies, commissions, boards, etc. as context requires.
  - 2.8 "Vendor" or "Vendors" means any entity submitting a bid in response to the Solicitation, the entity that has been selected as the lowest responsible bidder, or the entity that has been awarded the Contract as context requires.

3. **CONTRACT TERM; RENEWAL; EXTENSION:** The term of this Contract shall be determined in accordance with the category that has been identified as applicable to this Contract below:

**Term Contract**

**Initial Contract Term:** This Contract becomes effective on   
  
 and extends for a period of  year(s).

**Renewal Term:** This Contract may be renewed upon the mutual written consent of the Agency, and the Vendor, with approval of the Purchasing Division and the Attorney General's office (Attorney General approval is as to form only). Any request for renewal must be submitted to the Purchasing Division Director thirty (30) days prior to the expiration date of the initial contract term or appropriate renewal term. A Contract renewal shall be in accordance with the terms and conditions of the original contract. Renewal of this Contract is limited to  successive one (1) year periods. Automatic renewal of this Contract is prohibited. Notwithstanding the foregoing, Purchasing Division approval is not required on agency delegated or exempt purchases. Attorney General approval may be required for vendor terms and conditions.

**Reasonable Time Extension:** At the sole discretion of the Purchasing Division Director, and with approval from the Attorney General's office (Attorney General approval is as to form only), this Contract may be extended for a reasonable time after the initial Contract term or after any renewal term as may be necessary to obtain a new contract or renew this Contract. Any reasonable time extension shall not exceed twelve (12) months. Vendor may avoid a reasonable time extension by providing the Purchasing Division Director with written notice of Vendor's desire to terminate this Contract 30 days prior to the expiration of the then current term. During any reasonable time extension period, the Vendor may terminate this Contract for any reason upon giving the Purchasing Division Director 30 days written notice. Automatic extension of this Contract is prohibited. Notwithstanding the foregoing, Purchasing Division approval is not required on agency delegated or exempt purchases, but Attorney General approval may be required.

- Fixed Period Contract:** This Contract becomes effective upon Vendor's receipt of the notice to proceed and must be completed within  ninety (90)  days.
- One Time Purchase:** The term of this Contract shall run from the issuance of the Purchase Order until all of the goods contracted for have been delivered, but in no event shall this Contract extend for more than one fiscal year.
- Other:** See attached.

4. **NOTICE TO PROCEED:** Vendor shall begin performance of this Contract immediately upon receiving notice to proceed unless otherwise instructed by the Agency. Unless otherwise specified, the fully executed Purchase Order will be considered notice to proceed
5. **QUANTITIES:** The quantities required under this Contract shall be determined in accordance with the category that has been identified as applicable to this Contract below.
- Open End Contract:** Quantities listed in this Solicitation are approximations only, based on estimates supplied by the Agency. It is understood and agreed that the Contract shall cover the quantities actually ordered for delivery during the term of the Contract, whether more or less than the quantities shown.
- Service:** The scope of the service to be provided will be more clearly defined in the specifications included herewith.
- Combined Service and Goods:** The scope of the service and deliverable goods to be provided will be more clearly defined in the specifications included herewith.
- One Time Purchase:** This Contract is for the purchase of a set quantity of goods that are identified in the specifications included herewith. Once those items have been delivered, no additional goods may be procured under this Contract without an appropriate change order approved by the Vendor, Agency, Purchasing Division, and Attorney General's office.
6. **PRICING:** The pricing set forth herein is firm for the life of the Contract, unless specified elsewhere within this Solicitation/Contract by the State. A Vendor's inclusion of price adjustment provisions in its bid, without an express authorization from the State in the Solicitation to do so, may result in bid disqualification.
7. **EMERGENCY PURCHASES:** The Purchasing Division Director may authorize the Agency to purchase goods or services in the open market that Vendor would otherwise provide under this Contract if those goods or services are for immediate or expedited delivery in an emergency. Emergencies shall include, but are not limited to, delays in transportation or an unanticipated increase in the volume of work. An emergency purchase in the open market, approved by the Purchasing Division Director, shall not constitute a breach of this Contract and shall not entitle the Vendor to any form of compensation or damages. This provision does not excuse the State from fulfilling its obligations under a One Time Purchase contract.
8. **REQUIRED DOCUMENTS:** All of the items checked below must be provided to the Purchasing Division by the Vendor as specified below.
- BID BOND:** All Vendors shall furnish a bid bond in the amount of five percent (5%) of the total amount of the bid protecting the State of West Virginia. The bid bond must be submitted with the bid.

**PERFORMANCE BOND:** The apparent successful Vendor shall provide a performance bond in the amount of [\_\_\_\_\_]. The performance bond must be issued and received by the Purchasing Division prior to Contract award. On construction contracts, the performance bond must be 100% of the Contract value.

**LABOR/MATERIAL PAYMENT BOND:** The apparent successful Vendor shall provide a labor/material payment bond in the amount of 100% of the Contract value. The labor/material payment bond must be issued and delivered to the Purchasing Division prior to Contract award.

In lieu of the Bid Bond, Performance Bond, and Labor/Material Payment Bond, the Vendor may provide certified checks, cashier's checks, or irrevocable letters of credit. Any certified check, cashier's check, or irrevocable letter of credit provided in lieu of a bond must be of the same amount and delivered on the same schedule as the bond it replaces. A letter of credit submitted in lieu of a performance and labor/material payment bond will only be allowed for projects under \$100,000. Personal or business checks are not acceptable.

**MAINTENANCE BOND:** The apparent successful Vendor shall provide a two (2) year maintenance bond covering the roofing system. The maintenance bond must be issued and delivered to the Purchasing Division prior to Contract award.

**WORKERS' COMPENSATION INSURANCE:** The apparent successful Vendor shall have appropriate workers' compensation insurance and shall provide proof thereof upon request.

**INSURANCE:** The apparent successful Vendor shall furnish proof of the following insurance prior to Contract award:

**Commercial General Liability Insurance:**  
[ \$1,000,000.00 ] or more.

**Builders Risk Insurance:** builders risk – all risk insurance in an amount equal to 100% of the amount of the Contract.

[\_\_\_\_\_]

[\_\_\_\_\_]

[\_\_\_\_\_]

[\_\_\_\_\_]

[\_\_\_\_\_]

The apparent successful Vendor shall also furnish proof of any additional insurance requirements contained in the specifications prior to Contract award regardless of whether or not that insurance requirement is listed above.

] **LICENSE(S) / CERTIFICATIONS / PERMITS:** In addition to anything required under the Section entitled Licensing, of the General Terms and Conditions, the apparent successful Vendor shall furnish proof of the following licenses, certifications, and/or permits prior to Contract award, in a form acceptable to the Purchasing Division.

<input type="checkbox"/> ]	
<input type="checkbox"/> ]	
<input type="checkbox"/> ]	
<input type="checkbox"/> ]	

The apparent successful Vendor shall also furnish proof of any additional licenses or certifications contained in the specifications prior to Contract award regardless of whether or not that requirement is listed above.

**9. LITIGATION BOND:** The Director reserves the right to require any Vendor that files a protest of an award to submit a litigation bond in the amount equal to one percent of the lowest bid submitted or \$5,000, whichever is greater. The entire amount of the bond shall be forfeited if the hearing officer determines that the protest was filed for frivolous or improper purpose, including but not limited to, the purpose of harassing, causing unnecessary delay, or needless expense for the Agency. All litigation bonds shall be made payable to the Purchasing Division. In lieu of a bond, the protester may submit a cashier's check or certified check payable to the Purchasing Division. Cashier's or certified checks will be deposited with and held by the State Treasurer's office. If it is determined that the protest has not been filed for frivolous or improper purpose, the bond or deposit shall be returned in its entirety.

**10. ALTERNATES:** Any model, brand, or specification listed herein establishes the acceptable level of quality only and is not intended to reflect a preference for, or in any way favor, a particular brand or vendor. Vendors may bid alternates to a listed model or brand provided that the alternate is at least equal to the model or brand and complies with the required specifications. The equality of any alternate being bid shall be determined by the State at its sole discretion. Any Vendor bidding an alternate model or brand should clearly identify the alternate items in its bid and should include manufacturer's specifications, industry literature, and/or any other relevant documentation demonstrating the equality of the alternate items. Failure to provide information for alternate items may be grounds for rejection of a Vendor's bid.

**11. EXCEPTIONS AND CLARIFICATIONS:** The Solicitation contains the specifications that shall form the basis of a contractual agreement. Vendor shall clearly mark any exceptions, clarifications, or

other proposed modifications in its bid. Exceptions to, clarifications of, or modifications of a requirement or term and condition of the Solicitation may result in bid disqualification.

**12. LIQUIDATED DAMAGES:** Vendor shall pay liquidated damages in the amount

	for	

This clause shall in no way be considered exclusive and shall not limit the State or Agency's right to pursue any other available remedy.

**13. ACCEPTANCE/REJECTION:** The State may accept or reject any bid in whole, or in part. Vendor's signature on its bid signifies acceptance of the terms and conditions contained in the Solicitation and Vendor agrees to be bound by the terms of the Contract, as reflected in the Purchase Order, upon receipt.

**14. REGISTRATION:** Prior to Contract award, the apparent successful Vendor must be properly registered with the West Virginia Purchasing Division and must have paid the \$125 fee if applicable.

**15. COMMUNICATION LIMITATIONS:** In accordance with West Virginia Code of State Rules §148-1-6.6, communication with the State of West Virginia or any of its employees regarding this Solicitation during the solicitation, bid, evaluation or award periods, except through the Purchasing Division, is strictly prohibited without prior Purchasing Division approval. Purchasing Division approval for such communication is implied for all agency delegated and exempt purchases.

**16. FUNDING:** This Contract shall continue for the term stated herein, contingent upon funds being appropriated by the Legislature or otherwise being made available. In the event funds are not appropriated or otherwise made available, this Contract becomes void and of no effect beginning on July 1 of the fiscal year for which funding has not been appropriated or otherwise made available.

**17. PAYMENT:** Payment in advance is prohibited under this Contract. Payment may only be made after the delivery and acceptance of goods or services. The Vendor shall submit invoices, in arrears, to the Agency at the address on the face of the purchase order labeled "Invoice To."

**18. UNIT PRICE:** Unit prices shall prevail in cases of a discrepancy in the Vendor's bid.

**19. DELIVERY:** All quotations are considered freight on board destination ("F.O.B. destination") unless alternate shipping terms are clearly identified in the bid. Vendor's listing of shipping terms that contradict the shipping terms expressly required by this Solicitation may result in bid disqualification.

**20. INTEREST:** Interest attributable to late payment will only be permitted if authorized by the West Virginia Code. Presently, there is no provision in the law for interest on late payments.

**21. PREFERENCE:** Vendor Preference may only be granted upon written request and only in accordance with the West Virginia Code § 5A-3-37 and the West Virginia Code of State Rules. A Resident Vendor Certification form has been attached hereto to allow Vendor to apply for the preference. Vendor's



failure to submit the Resident Vendor Certification form with its bid will result in denial of Vendor Preference. Vendor Preference does not apply to construction projects.

22. **SMALL, WOMEN-OWNED, OR MINORITY-OWNED BUSINESSES:** For any solicitations publicly advertised for bid on or after July 1, 2012, in accordance with West Virginia Code §5A-3-37(a)(7) and W. Va. CSR § 148-22-9, any non-resident vendor certified as a small, women-owned, or minority-owned business under W. Va. CSR § 148-22-9 shall be provided the same preference made available to any resident vendor. Any non-resident small, women-owned, or minority-owned business must identify itself as such in writing, must submit that writing to the Purchasing Division with its bid, and must be properly certified under W. Va. CSR § 148-22-9 prior to submission of its bid to receive the preferences made available to resident vendors. Preference for a non-resident small, women-owned, or minority owned business shall be applied in accordance with W. Va. CSR § 148-22-9.
23. **TAXES:** The Vendor shall pay any applicable sales, use, personal property or any other taxes arising out of this Contract and the transactions contemplated thereby. The State of West Virginia is exempt from federal and state taxes and will not pay or reimburse such taxes.
24. **CANCELLATION:** The Purchasing Division Director reserves the right to cancel this Contract immediately upon written notice to the vendor if the materials or workmanship supplied do not conform to the specifications contained in the Contract. The Purchasing Division Director may cancel any purchase or Contract upon 30 days written notice to the Vendor in accordance with West Virginia Code of State Rules § 148-1-7.16.2.
25. **WAIVER OF MINOR IRREGULARITIES:** The Director reserves the right to waive minor irregularities in bids or specifications in accordance with West Virginia Code of State Rules § 148-1-4.6.
26. **TIME:** Time is of the essence with regard to all matters of time and performance in this Contract.
27. **APPLICABLE LAW:** This Contract is governed by and interpreted under West Virginia law without giving effect to its choice of law principles. Any information provided in specification manuals, or any other source, verbal or written, which contradicts or violates the West Virginia Constitution, West Virginia Code or West Virginia Code of State Rules is void and of no effect.
28. **COMPLIANCE:** Vendor shall comply with all applicable federal, state, and local laws, regulations and ordinances. By submitting a bid, Vendors acknowledge that they have reviewed, understand, and will comply with all applicable law.
29. **PREVAILING WAGE:** On any contract for the construction of a public improvement, Vendor and any subcontractors utilized by Vendor shall pay a rate or rates of wages which shall not be less than the fair minimum rate or rates of wages (prevailing wage), as established by the West Virginia Division of Labor under West Virginia Code §§ 21-5A-1 et seq. and available at <http://www.sos.wv.gov/administrative-law/wagerates/Pages/default.aspx>. Vendor shall be responsible for ensuring compliance with prevailing wage requirements and determining when prevailing wage



requirements are applicable. The required contract provisions contained in West Virginia Code of State Rules § 42-7-3 are specifically incorporated herein by reference.

30. **ARBITRATION:** Any references made to arbitration contained in this Contract, Vendor's bid, or in any American Institute of Architects documents pertaining to this Contract are hereby deleted, void, and of no effect.
31. **MODIFICATIONS:** This writing is the parties' final expression of intent. Notwithstanding anything contained in this Contract to the contrary, no modification of this Contract shall be binding without mutual written consent of the Agency, and the Vendor, with approval of the Purchasing Division and the Attorney General's office (Attorney General approval is as to form only). **No Change shall be implemented by the Vendor until such time as the Vendor receives an approved written change order from the Purchasing Division.**
32. **WAIVER:** The failure of either party to insist upon a strict performance of any of the terms or provision of this Contract, or to exercise any option, right, or remedy herein contained, shall not be construed as a waiver or a relinquishment for the future of such term, provision, option, right, or remedy, but the same shall continue in full force and effect. Any waiver must be expressly stated in writing and signed by the waiving party.
33. **SUBSEQUENT FORMS:** The terms and conditions contained in this Contract shall supersede any and all subsequent terms and conditions which may appear on any form documents submitted by Vendor to the Agency or Purchasing Division such as price lists, order forms, invoices, sales agreements, or maintenance agreements, and includes internet websites or other electronic documents. Acceptance or use of Vendor's forms does not constitute acceptance of the terms and conditions contained thereon.
34. **ASSIGNMENT:** Neither this Contract nor any monies due, or to become due hereunder, may be assigned by the Vendor without the express written consent of the Agency, the Purchasing Division, the Attorney General's office (as to form only), and any other government agency or office that may be required to approve such assignments. Notwithstanding the foregoing, Purchasing Division approval may or may not be required on certain agency delegated or exempt purchases.
35. **WARRANTY:** The Vendor expressly warrants that the goods and/or services covered by this Contract will: (a) conform to the specifications, drawings, samples, or other description furnished or specified by the Agency; (b) be merchantable and fit for the purpose intended; and (c) be free from defect in material and workmanship.
36. **STATE EMPLOYEES:** State employees are not permitted to utilize this Contract for personal use and the Vendor is prohibited from permitting or facilitating the same.
37. **BANKRUPTCY:** In the event the Vendor files for bankruptcy protection, the State of West Virginia may deem this Contract null and void, and terminate this Contract without notice.

- 38. HIPAA BUSINESS ASSOCIATE ADDENDUM:** The West Virginia State Government HIPAA Business Associate Addendum (BAA), approved by the Attorney General, is available online at <http://www.state.wv.us/admin/purchase/vrc/hipaa.html> and is hereby made part of the agreement provided that the Agency meets the definition of a Covered entity (45 CFR §160.103) and will be disclosing Protected Health Information (45 CFR §160.103) to the Vendor. Additionally, the HIPAA Privacy, Security, Enforcement & Breach Notification Final Omnibus Rule was published on January 25, 2013. It may be viewed online at <http://www.gpo.gov/fdsys/pkg/FR-2013-01-25/pdf/2013-01073.pdf>. Any organization, that qualifies as the Agency's Business Associate, is expected to be in compliance with this Final Rule. For those Business Associates entering into contracts with a HIPAA Covered State Agency between January 25, 2013 and the release of the 2013 WV State Agency Business Associate Agreement, or September 23, 2013 (whichever is earlier), be advised that you will be required to comply with the 2013 WV State Agency Business Associate Agreement. For those Business Associates with contracts with a HIPAA Covered State Agency executed prior to January 25, 2013, be advised that upon renewal or modification, you will be required to comply with the 2013 WV State Agency Business Associate Agreement no later than September 22, 2014.
- 39. CONFIDENTIALITY:** The Vendor agrees that it will not disclose to anyone, directly or indirectly, any such personally identifiable information or other confidential information gained from the Agency, unless the individual who is the subject of the information consents to the disclosure in writing or the disclosure is made pursuant to the Agency's policies, procedures, and rules. Vendor further agrees to comply with the Confidentiality Policies and Information Security Accountability Requirements, set forth in <http://www.state.wv.us/admin/purchase/privacy/default.html>.
- 40. DISCLOSURE:** Vendor's response to the Solicitation and the resulting Contract are considered public documents and will be disclosed to the public in accordance with the laws, rules, and policies governing the West Virginia Purchasing Division. Those laws include, but are not limited to, the Freedom of Information Act found in West Virginia Code § 29B-1-1 et seq.

If a Vendor considers any part of its bid to be exempt from public disclosure, Vendor must so indicate by specifically identifying the exempt information, identifying the exemption that applies, providing a detailed justification for the exemption, segregating the exempt information from the general bid information, and submitting the exempt information as part of its bid but in a segregated and clearly identifiable format. Failure to comply with the foregoing requirements will result in public disclosure of the Vendor's bid without further notice. A Vendor's act of marking all or nearly all of its bid as exempt is not sufficient to avoid disclosure and WILL NOT BE HONORED. Vendor's act of marking a bid or any part thereof as "confidential" or "proprietary" is not sufficient to avoid disclosure and WILL NOT BE HONORED. In addition, a legend or other statement indicating that all or substantially all of the bid is exempt from disclosure is not sufficient to avoid disclosure and WILL NOT BE HONORED. Vendor will be required to defend any claimed exemption for nondisclosure in the event of an administrative or judicial challenge to the State's nondisclosure. Vendor must indemnify the State for any costs incurred related to any exemptions claimed by Vendor. Any questions regarding the applicability of the various public records laws should be addressed to your own legal counsel prior to bid submission.

- 41. LICENSING:** In accordance with West Virginia Code of State Rules §148-1-6.1.7, Vendor must be licensed and in good standing in accordance with any and all state and local laws and requirements by any state or local agency of West Virginia, including, but not limited to, the West Virginia Secretary of State's Office, the West Virginia Tax Department, West Virginia Insurance Commission, or any other state agency or political subdivision. Upon request, the Vendor must provide all necessary releases to obtain information to enable the Purchasing Division Director or the Agency to verify that the Vendor is licensed and in good standing with the above entities.
- 42. ANTITRUST:** In submitting a bid to, signing a contract with, or accepting a Purchase Order from any agency of the State of West Virginia, the Vendor agrees to convey, sell, assign, or transfer to the State of West Virginia all rights, title, and interest in and to all causes of action it may now or hereafter acquire under the antitrust laws of the United States and the State of West Virginia for price fixing and/or unreasonable restraints of trade relating to the particular commodities or services purchased or acquired by the State of West Virginia. Such assignment shall be made and become effective at the time the purchasing agency tenders the initial payment to Vendor.
- 43. VENDOR CERTIFICATIONS:** By signing its bid or entering into this Contract, Vendor certifies (1) that its bid was made without prior understanding, agreement, or connection with any corporation, firm, limited liability company, partnership, person or entity submitting a bid for the same material, supplies, equipment or services; (2) that its bid is in all respects fair and without collusion or fraud; (3) that this Contract is accepted or entered into without any prior understanding, agreement, or connection to any other entity that could be considered a violation of law; and (4) that it has reviewed this RFQ in its entirety; understands the requirements, terms and conditions, and other information contained herein. Vendor's signature on its bid also affirms that neither it nor its representatives have any interest, nor shall acquire any interest, direct or indirect, which would compromise the performance of its services hereunder. Any such interests shall be promptly presented in detail to the Agency.

The individual signing this bid on behalf of Vendor certifies that he or she is authorized by the Vendor to execute this bid or any documents related thereto on Vendor's behalf; that he or she is authorized to bind the Vendor in a contractual relationship; and that, to the best of his or her knowledge, the Vendor has properly registered with any State agency that may require registration.

- 44. PURCHASING CARD ACCEPTANCE:** The State of West Virginia currently utilizes a Purchasing Card program, administered under contract by a banking institution, to process payment for goods and services. The Vendor must accept the State of West Virginia's Purchasing Card for payment of all orders under this Contract unless the box below is checked.

Vendor is not required to accept the State of West Virginia's Purchasing Card as payment for all goods and services.

- 45. VENDOR RELATIONSHIP:** The relationship of the Vendor to the State shall be that of an independent contractor and no principal-agent relationship or employer-employee relationship is contemplated or created by this Contract. The Vendor as an independent contractor is solely liable for the acts and omissions of its employees and agents. Vendor shall be responsible for selecting,

supervising, and compensating any and all individuals employed pursuant to the terms of this Solicitation and resulting contract. Neither the Vendor, nor any employees or subcontractors of the Vendor, shall be deemed to be employees of the State for any purpose whatsoever. Vendor shall be exclusively responsible for payment of employees and contractors for all wages and salaries, taxes, withholding payments, penalties, fees, fringe benefits, professional liability insurance premiums, contributions to insurance and pension, or other deferred compensation plans, including but not limited to, Workers' Compensation and Social Security obligations, licensing fees, *etc.* and the filing of all necessary documents, forms and returns pertinent to all of the foregoing. Vendor shall hold harmless the State, and shall provide the State and Agency with a defense against any and all claims including, but not limited to, the foregoing payments, withholdings, contributions, taxes, Social Security taxes, and employer income tax returns.

- 46. INDEMNIFICATION:** The Vendor agrees to indemnify, defend, and hold harmless the State and the Agency, their officers, and employees from and against: (1) Any claims or losses for services rendered by any subcontractor, person, or firm performing or supplying services, materials, or supplies in connection with the performance of the Contract; (2) Any claims or losses resulting to any person or entity injured or damaged by the Vendor, its officers, employees, or subcontractors by the publication, translation, reproduction, delivery, performance, use, or disposition of any data used under the Contract in a manner not authorized by the Contract, or by Federal or State statutes or regulations; and (3) Any failure of the Vendor, its officers, employees, or subcontractors to observe State and Federal laws including, but not limited to, labor and wage and hour laws.
- 47. PURCHASING AFFIDAVIT:** In accordance with West Virginia Code § 5A-3-10a, all Vendors are required to sign, notarize, and submit the Purchasing Affidavit stating that neither the Vendor nor a related party owe a debt to the State in excess of \$1,000. The affidavit must be submitted prior to award, but should be submitted with the Vendor's bid. A copy of the Purchasing Affidavit is included herewith.
- 48. ADDITIONAL AGENCY AND LOCAL GOVERNMENT USE:** This Contract may be utilized by and extends to other agencies, spending units, and political subdivisions of the State of West Virginia; county, municipal, and other local government bodies; and school districts ("Other Government Entities"). This Contract shall be extended to the aforementioned Other Government Entities on the same prices, terms, and conditions as those offered and agreed to in this Contract. If the Vendor does not wish to extend the prices, terms, and conditions of its bid and subsequent contract to the Other Government Entities, the Vendor must clearly indicate such refusal in its bid. A refusal to extend this Contract to the Other Government Entities shall not impact or influence the award of this Contract in any manner.
- 49. CONFLICT OF INTEREST:** Vendor, its officers or members or employees, shall not presently have or acquire any interest, direct or indirect, which would conflict with or compromise the performance of its obligations hereunder. Vendor shall periodically inquire of its officers, members and employees to ensure that a conflict of interest does not arise. Any conflict of interest discovered shall be promptly presented in detail to the Agency.

**50. REPORTS:** Vendor shall provide the Agency and/or the Purchasing Division with the following reports identified by a checked box below:

- Such reports as the Agency and/or the Purchasing Division may request. Requested reports may include, but are not limited to, quantities purchased, agencies utilizing the contract, total contract expenditures by agency, etc.
- Quarterly reports detailing the total quantity of purchases in units and dollars, along with a listing of purchases by agency. Quarterly reports should be delivered to the Purchasing Division via email at [purchasing.requisitions@wv.gov](mailto:purchasing.requisitions@wv.gov).

**51. BACKGROUND CHECK:** In accordance with W. Va. Code § 15-2D-3, the Director of the Division of Protective Services shall require any service provider whose employees are regularly employed on the grounds or in the buildings of the Capitol complex or who have access to sensitive or critical information to submit to a fingerprint-based state and federal background inquiry through the state repository. The service provider is responsible for any costs associated with the fingerprint-based state and federal background inquiry.

After the contract for such services has been approved, but before any such employees are permitted to be on the grounds or in the buildings of the Capitol complex or have access to sensitive or critical information, the service provider shall submit a list of all persons who will be physically present and working at the Capitol complex to the Director of the Division of Protective Services for purposes of verifying compliance with this provision.

The State reserves the right to prohibit a service provider's employees from accessing sensitive or critical information or to be present at the Capitol complex based upon results addressed from a criminal background check.

Service providers should contact the West Virginia Division of Protective Services by phone at (304) 558-9911 for more information.

**52. PREFERENCE FOR USE OF DOMESTIC STEEL PRODUCTS:** Except when authorized by the Director of the Purchasing Division pursuant to W. Va. Code § 5A-3-56, no contractor may use or supply steel products for a State Contract Project other than those steel products made in the United States. A contractor who uses steel products in violation of this section may be subject to civil penalties pursuant to W. Va. Code § 5A-3-56. As used in this section:

- a. "State Contract Project" means any erection or construction of, or any addition to, alteration of or other improvement to any building or structure, including, but not limited to, roads or highways, or the installation of any heating or cooling or ventilating plants or other equipment, or the supply of and materials for such projects, pursuant to a contract with the State of West Virginia for which bids were solicited on or after June 6, 2001.
- b. "Steel Products" means products rolled, formed, shaped, drawn, extruded, forged, cast, fabricated or otherwise similarly processed, or processed by a combination of two or more or



such operations, from steel made by the open hearth, basic oxygen, electric furnace, Bessemer or other steel making process.

The Purchasing Division Director may, in writing, authorize the use of foreign steel products if:

- a. The cost for each contract item used does not exceed one tenth of one percent (.1%) of the total contract cost or two thousand five hundred dollars (\$2,500.00), whichever is greater. For the purposes of this section, the cost is the value of the steel product as delivered to the project; or
- b. The Director of the Purchasing Division determines that specified steel materials are not produced in the United States in sufficient quantity or otherwise are not reasonably available to meet contract requirements.

**53. PREFERENCE FOR USE OF DOMESTIC ALUMINUM, GLASS, AND STEEL:** In Accordance with W. Va. Code § 5-19-1 et seq., and W. Va. CSR § 148-10-1 et seq., for every contract or subcontract, subject to the limitations contained herein, for the construction, reconstruction, alteration, repair, improvement or maintenance of public works or for the purchase of any item of machinery or equipment to be used at sites of public works, only domestic aluminum, glass or steel products shall be supplied unless the spending officer determines, in writing, after the receipt of offers or bids, (1) that the cost of domestic aluminum, glass or steel products is unreasonable or inconsistent with the public interest of the State of West Virginia, (2) that domestic aluminum, glass or steel products are not produced in sufficient quantities to meet the contract requirements, or (3) the available domestic aluminum, glass, or steel do not meet the contract specifications. This provision only applies to public works contracts awarded in an amount more than fifty thousand dollars (\$50,000) or public works contracts that require more than ten thousand pounds of steel products.

The cost of domestic aluminum, glass, or steel products may be unreasonable if the cost is more than twenty percent (20%) of the bid or offered price for foreign made aluminum, glass, or steel products. If the domestic aluminum, glass or steel products to be supplied or produced in a "substantial labor surplus area", as defined by the United States Department of Labor, the cost of domestic aluminum, glass, or steel products may be unreasonable if the cost is more than thirty percent (30%) of the bid or offered price for foreign made aluminum, glass, or steel products.

This preference shall be applied to an item of machinery or equipment, as indicated above, when the item is a single unit of equipment or machinery manufactured primarily of aluminum, glass or steel, is part of a public works contract and has the sole purpose or of being a permanent part of a single public works project. This provision does not apply to equipment or machinery purchased by a spending unit for use by that spending unit and not as part of a single public works project.

All bids and offers including domestic aluminum, glass or steel products that exceed bid or offer prices including foreign aluminum, glass or steel products after application of the preferences provided in this provision may be reduced to a price equal to or lower than the lowest bid or offer price for foreign aluminum, glass or steel products plus the applicable preference. If the reduced bid or offer prices are made in writing and supersede the prior bid or offer prices, all bids or offers, including the reduced bid or offer prices, will be reevaluated in accordance with this rule.

**ADDITIONAL TERMS AND CONDITIONS (Construction Contracts Only)**

1. **CONTRACTOR'S LICENSE:** West Virginia Code § 21-11-2 requires that all persons desiring to perform contracting work in this state be licensed. The West Virginia Contractors Licensing Board is empowered to issue the contractor's license. Applications for a contractor's license may be made by contacting the West Virginia Division of Labor.

West Virginia Code § 21-11-11 requires any prospective Vendor to include the contractor's license number on its bid. Failure to include a contractor's license number on the bid shall result in Vendor's bid being disqualified. Vendors should include a contractor's license number in the space provided below.

Contractor's Name: DANHILL CONSTRUCTION COMPANY

Contractor's License No. WV001196

The apparent successful Vendor must furnish a copy of its contractor's license prior to the issuance of a purchase order/contract.

2. **DRUG-FREE WORKPLACE:** W. Va. Code § 21-1D-5 provides that any solicitation for a public improvement contract requires each Vendor that submits a bid for the work to submit at the same time an affidavit that the Vendor has a written plan for a drug-free workplace policy. To comply with this law, Vendor must either complete the enclosed drug-free workplace affidavit and submit the same with its bid or complete a similar affidavit that fulfills all of the requirements of the applicable code. Failure to submit the signed and notarized drug-free workplace affidavit, or a similar affidavit that fully complies with the requirements of the applicable code, with the bid shall result in disqualification of Vendor's bid.
3. **AIA DOCUMENTS:** All construction contracts that will be completed in conjunction with architectural services procured under Chapter 5G of the West Virginia Code will be governed by the AIA A101-2007 and A201-2007 or the A107-2007 documents, as amended by the Supplementary Conditions for the State of West Virginia, in addition to the terms and conditions contained herein.
4. **SUBCONTRACTOR LIST SUBMISSION:** In accordance with W. Va. Code § 5-22-1, The apparent low bidder on a contract for the construction, alteration, decoration, painting or improvement of a new or existing building or structure valued at more than \$500,000.00 shall submit a list of all subcontractors who will perform more than \$25,000.00 of work on the project including labor and materials. This provision shall not apply to any other construction projects, such as highway, mine reclamation, water or sewer projects.



c. **Required Information.** The subcontractor list shall contain the following information:

- i. Bidder's name
- ii. Name of each subcontractor
- iii. License numbers as required by W. Va. Code § 21-11-1 et. seq.
- iv. Notation that no subcontractors will be used if the bidder will perform the work

d. **Submission.** The completed subcontractor list shall be provided to the Purchasing Division within one business day of the opening of bids for review. Failure to submit the subcontractor list within one business day after the deadline for submitting bids shall result in disqualification of the bid.

e. **Substitution of Subcontractor.** Written approval must be obtained from the Purchasing Division before any subcontractor substitution is permitted. Substitutions are not permitted unless:

- i. The subcontractor listed in the original bid has filed for bankruptcy;
- ii. The subcontractor in the original bid has been debarred or suspended; or
- iii. The contractor certifies in writing that the subcontractor listed in the original bill fails, is unable, or refuses to perform his subcontract.

5. **GREEN BUILDINGS MINIMUM ENERGY STANDARDS:** In accordance with § 22-29-4, all new building construction projects of public agencies that have not entered the schematic design phase prior to July 1, 2012, or any building construction project receiving state grant funds and appropriations, including public schools, that have not entered the schematic design phase prior to July 1, 2012, shall be designed and constructed complying with the ICC International Energy Conservation Code, adopted by the State Fire Commission, and the ANSI/ASHRAE/IESNA Standard 90.1-2007: *Provided*, That if any construction project has a commitment of federal funds to pay for a portion of such project, this provision shall only apply to the extent such standards are consistent with the federal standards.

REQUEST FOR QUOTATION  
AGR1332                      Post Frame Office and Shop Building

---

SPECIFICATIONS

1. **PURPOSE AND SCOPE:** The West Virginia Purchasing Division is soliciting bids on behalf of the West Virginia Department of Agriculture (WVDA) to establish a contract for the one time purchase of labor and materials required to construct a pre-engineered post frame office and shop building at the West Virginia Department of Agriculture, Huttonsville Farm, Route 250 South, Huttonsville, WV, as stated herein.
  
2. **DEFINITIONS:** The terms listed below shall have the meanings assigned to them below. Additional definitions can be found in section 2 of the General Terms and Conditions.
  - 2.1 **“Contract Item”** means pre-engineered post frame office and shop building.
  
  - 2.2 **“Pricing Page”** means the pages upon which Vendor should list its proposed price for the Contract Items in the manner requested. The Pricing Page is either included on the last page of this RFQ or attached hereto as Exhibit A.
  
  - 2.3 **“RFQ”** means the official request for quotation published by the Purchasing Division and identified as AGR1332.
  
3. **GENERAL REQUIREMENTS:**
  - 3.1 **Mandatory Contract Item Requirements:** Contract Item must meet or exceed the mandatory requirements listed below.
    - 3.1.1 **Post Frame Office and Shop Building**
      - 3.1.1.1 Post frame office and shop building must be in compliance with the 2009 International Building Code. ([WWW.iccsafe.org](http://WWW.iccsafe.org))
  
      - 3.1.1.2 Post frame office and shop building must be in accordance with Randolph County and West Virginia State building codes for this location.
  
      - 3.1.1.3 The Contractor will acquire all necessary permits and licenses to comply with applicable laws, Federal, State, or Municipal and all regulations or ordinances of any regulating body.
  
      - 3.1.1.4 Contractor must supply all materials, tools, tool accessories, personal safety equipment, and supplies necessary to complete the responsibilities of

REQUEST FOR QUOTATION  
AGR1332                      Post Frame Office and Shop Building

---

this contract. Contractor will be responsible for the removal of all waste and debris on a daily basis, as a result of performing this contract.

3.1.1.5 Contractor will be responsible for all mileage and travel costs, including travel time associated with this contract.

3.1.1.6 West Virginia State Code §21-11-2 requires that all persons desiring to perform contracting work in this State must be licensed. The Contractor must furnish a copy of their contractor's license prior to issuance of a purchase order/contract.

3.1.1.7 Contractor must furnish proof of commercial general liability insurance prior to issuance of contract. Unless otherwise specified in the bid documents, the minimum amount of insurance coverage required is \$1,000,000.00 (one million dollars)

3.1.1.8 Any damage to WVDA property from misuse or abuse by the Contractor or their workers will be repaired or replaced by the Contractor at no expense to the WVDA.

3.1.1.9 Sanitary facilities will not be available. The Contractor will be responsible for the provision and maintenance of portable toilets or their equal.

3.1.1.10 A trailer or temporary storage building must be set on the site by the Contractor to secure all equipment and tools. The location of storage area must be approved by the WVDA contact. The Contractor is responsible for his tools, equipment, and materials.

3.1.1.11 Access to the worksite is limited to Monday through Saturday, between 6:00A.M. and 5:00P.M.

3.1.1.12 Any and all work to be performed to successfully execute the terms of this contract by a third party or sub-contractor, must be pre-approved by the owner or their representative. All such work will remain the responsibility of the successful bidder/contractor with regard to all labor, materials, and fees associated with the sub-contracting and any and all associated responsibilities. Under no circumstances will the contractor transfer

REQUEST FOR QUOTATION  
AGR1332                      Post Frame Office and Shop Building

---

responsibility for any work as described herein by a third party or sub-contractor.

**3.1.1.13** The job will be turn-key for all labor, materials, and equipment necessary to complete the project.

**3.1.1.14** Construction shop drawings stamped and signed by a professional engineer licensed by the State of West Virginia must be submitted for review and approval along with "as-built" on sight drawings. Drawings must meet the 2006 International Building Code and other applicable codes required by the State of West Virginia.

**3.1.1.15** Post frame office and shop building will be attached to existing concrete pad using approved fastening system according to building manufacturers specifications. Outside measurements to be 46'8" (forty-six foot eight inch) wide by 65' (sixty-five foot) long by 16' (sixteen) foot high to bottom of trusses.

**3.1.1.16** Overhang is not required on new building.

**3.1.1.17** Posts, secondary framing, purlins, girts, and permanent bracing shall be installed per the design of building manufacturer.

**3.1.1.18** All roofing, siding, trims, gutters, downspouts, and flashings shall be furnished in a standard color to match the existing building, and be installed per building manufacturer's instructions

**3.1.1.19** The post frame office and shop building will be constructed 10' from the new post frame barn that was built in 2012, as shown on WVDA drawing No.1 (refer to attachments).

**3.1.1.20** South wall of building will have one 3'0" x 6' 8" commercial steel door located across from door on existing building, as shown on WVDA drawing No.1 (refer to attachments).

**3.1.1.21** East wall of post frame office and shop building to have two operational, insulated sectional, commercial overhead steel garage doors as shown in WVDA drawing No.5 with electronic openers. One 12' wide by 14'

REQUEST FOR QUOTATION  
AGRI1332                      Post Frame Office and Shop Building

---

high, the other 16' wide by 14' high. East wall also to have one 3'0" x 6'8" commercial steel door next to office also shown on WVDA drawing No.1. Exterior doors to be 18 gauge minimum such as Steelcraft Galvannealed L-18 or equal.

**3.1.1.22** Exterior doors will have 4"x25" light. Doors and frames will be primed and finish painted to match color of doors on existing building and have commercial door closers Norton brand 1600 or equal. Locks will be keyed alike lever type Sargent 28CLL26D with panic device 3828FEN or equal.

**3.1.1.23** Interior walls and ceiling of shop area will be covered with white uni-rib 29 gauge galvanized steel with R-19 insulation with vapor barrier for all exterior walls and bottom cord of roof trusses

**3.1.1.24** Roof of post frame office and shop building will be insulated with 2" (two inch) R-6 PFSK fiberglass insulation.

**3.1.1.25** Snow retention system will be installed in accordance to manufacturer's instructions with special consideration for protection over doors and gutters.

**3.1.1.26** Inside office space will be constructed in the inside north east corner of the post frame office and shop building, as shown on WVDA drawings Nos.1, 7, & 8 to the outside dimensions of 24' x 12' x 9' (nine foot) height, with 2"x6" framing 16" on center with double top plate.

**3.1.1.27** Overhead storage area of office will be constructed of 2"x12" southern yellow pine floor joist with ¾" Advantech (or equal) sheathing applied with construction adhesive and manufacturer approved fasteners.

**3.1.1.28** Office area will have one ADA compliant unisex restroom with one commode and one sink as shown on WVDA drawing No.1.

**3.1.1.29** Office area will have one shower room with 60" shower, as also shown on WVDA drawing No.1

REQUEST FOR QUOTATION  
AGR1332                      Post Frame Office and Shop Building

---

**3.1.1.30** Shower and restroom will be supplied with a 28 (twenty eight) gallon electric water heater, Whirlpool low profile E2F30LD35V or equal, installed overhead of shower room in overhead storage area. Water heater will have a drain pan installed under it and drain to outside of building. Restroom and shower and water heater to be supplied with ¾" soldered copper type "L" with ½" runs to the fixtures. WVDA to have water hook up available near shower wall as shown on WVDA drawing No.1. Contractor to do all plumbing and electrical hookups.

**3.1.1.31** Office area walls and area between overhead storage will be insulated with R-19 for noise reduction.

**3.1.1.32** Inside office walls will have 5/8" Fire code type X drywall with a ceiling height of 8' (eight foot). Taped, finished, primed and painted with Sherwin Williams Pro-Mar 200 Dover White or equal.

**3.1.1.33** Inside restroom and shower room walls will have 5/8" Firecode type X drywall taped and primed and covered with white FRP (fiberglass reinforced plastic) that is installed with Titebond Fast Grab FRP adhesive or equal.

**3.1.1.34** Ceiling in office areas to be CertainTeed Bet-17, 2'x4' lay-in tiles or equal with commercial grade track system. Ceiling height in office, shower, and restroom to be 8'.

**3.1.1.35** Lighting in office area to consist of two 2x4 lay-in Cooper 2GR8-432A four-lamp fixtures or equal, and restroom and shower to have one each Cooper 2GR8-232A two-lamp fixtures or equal, as shown in WVDA drawing No.3.

**3.1.1.36** Contractor shall furnish and install a 200-amp electrical system for Post Office and Shop building complete with panel box Square D model Q0140M200, single phase 40 circuit 200-amp with cover Q0C40US or equal. All electrical work will be installed in compliance to the latest National Electric Code. All interior wiring will be copper and in EMT (thin wall) conduit.

REQUEST FOR QUOTATION  
AGR1332                      Post Frame Office and Shop Building

---

3.1.1.37 Shop to have seventeen, 120 volt duplex receptacles spaced every 10' as shown on WVDA drawing No.2 Two, 250-volt 30-amp receptacles for welder and air compressor as shown on WVDA drawing No.2. Electric panel box to also have one, 250-volt 30-amp circuit for water heater. Exterior East wall to have two, 120-volt GFCI weatherproof outlets, as shown on WVDA drawing No.2.

3.1.1.38 Restroom and shower room to each have electric heater, Dayton SZK68 or equal, installed into walls. Office to have Packaged Thermal Air Conditioner (P.T.A.C.) unit General Electric AZ61H12DAB 11,800BTU or equal, with all wall sleeves and materials to install into North wall, as shown on WVDA drawing attachment No.1.

3.1.1.39 Inside office walls to have 8 (eight) 20- amp receptacles as shown on WVDA drawing No.2. Light switch mounted on inside wall by door. Restroom to have one 120 volt GFCI outlet.

3.1.1.40 Outside walls of office area in shop will be covered with white galvanized steel uni-rib 29 gauge panels.

3.1.1.41 Office to have 2 (two) white vinyl insulated windows installed per WVDA drawing No. 1. 1 (one) 48"x48" double hung in exterior east facing wall and 1 (one) 48"x48" deadlight facing out into shop, as also shown in drawing No.1.

3.1.1.42 All vinyl insulated windows are to meet the Energy Star Rating for Northern Climate Zone

3.1.1.43 Office area will have 3 (three) commercial steel doors 3'0"x6'8" with ADA rated hardware to be installed in restroom, as shown in WVDA drawing attachment No.1.

3.1.1.44 Shop area will have 6 Metalux HBI-654-T5-N-UNV-EHT2-U or equal light fixtures as shown in WVDA drawings attachment No.3. Lights in shop area to be controlled by 3-way switches located by both exterior doors, also shown in drawing No.3. Lights will have wire guards Metalux SWG/HBI-4FT-B or equal.



REQUEST FOR QUOTATION  
AGR1332                      Post Frame Office and Shop Building

---

3.1.1.45 East exterior wall will have 3 (three) exterior lights with photo-cell Lumark WPP25 250w Metal Halide Pulse Start or equal as shown in WVDA drawing No.4.

3.1.1.46 Drawings provided by the West Virginia Department of Agriculture are preliminary and for bid purposes only. FIELD MEASUREMENTS SHOULD BE MADE BY THE SUCCESSFUL CONTRACTOR BEFORE BIDDING AND ORDERING ANY MATERIALS.

**4. CONTRACT AWARD:**

**4.1 Contract Award:** The Contract is intended to provide Agencies with a purchase price for the Contract Items. The Contract shall be awarded to the Vendor that provides the Contract Item meeting the required specifications for the lowest overall total cost as shown on the Pricing Pages.

**4.2 Pricing Page:** Vendor should complete the Pricing Page in full as failure to complete the Pricing Page in its entirety may result in Vendor's bid being disqualified.

Notwithstanding the foregoing, the Purchasing Division may correct errors as it deems appropriate. Vendor should type the information into the Pricing Page to prevent errors in the evaluation.

**5. PAYMENT:**

**5.1 Payment:** Vendor shall accept payment in accordance with the payment procedures of the State of West Virginia.

REQUEST FOR QUOTATION  
AGR1332                      Post Frame Office and Shop Building

---

**6. DELIVERY AND RETURN:**

**6.1 Shipment and Delivery:** Vendor shall ship the Contract Items immediately after being awarded this Contract and receiving a purchase order or notice to proceed. Vendor shall deliver the Contract Items within 90 (ninety) working days after receiving a purchase order or notice to proceed. Contract Items must be delivered to West Virginia Department of Agriculture, Huttonsville Farm, Route 250 South, Huttonsville, WV 26273. Drop off location to be at the north end of pad where building will be constructed.

**6.2 Late Delivery:** The Agency placing the order under this Contract must be notified in writing if the shipment of the Contract Items will be delayed for any reason. Any delay in delivery that could cause harm to an Agency will be grounds for cancellation of the Contract, and/or obtaining the Contract Items from a third party.

Any Agency seeking to obtain the Contract Items from a third party under this provision must first obtain approval of the Purchasing Division.

**6.3 Delivery Payment/Risk of Loss:** Vendor shall deliver the Contract Items F.O.B. destination to the Agency's location.

**6.4 Return of Unacceptable Items:** If the Agency deems the Contract Items to be unacceptable, the Contract Items shall be returned to Vendor at Vendor's expense and with no restocking charge. Vendor shall either make arrangements for the return within five (5) days of being notified that items are unacceptable, or permit the Agency to arrange for the return and reimburse Agency for delivery expenses. If the original packaging cannot be utilized for the return, Vendor will supply the Agency with appropriate return packaging upon request. All returns of unacceptable items shall be F.O.B. the Agency's location. The returned product shall either be replaced, or the Agency shall receive a full credit or refund for the purchase price, at the Agency's discretion.

**6.5 Return Due to Agency Error:** Items ordered in error by the Agency will be returned for credit within 30 days of receipt, F.O.B. Vendor's location. Vendor shall not charge a restocking fee if returned products are in a resalable condition. Items shall be deemed to be in a resalable condition if they are unused and in the original packaging. Any restocking fee for items not in a resalable condition shall be the lower of the Vendor's customary restocking fee or 5% of the total invoiced value of the returned items.

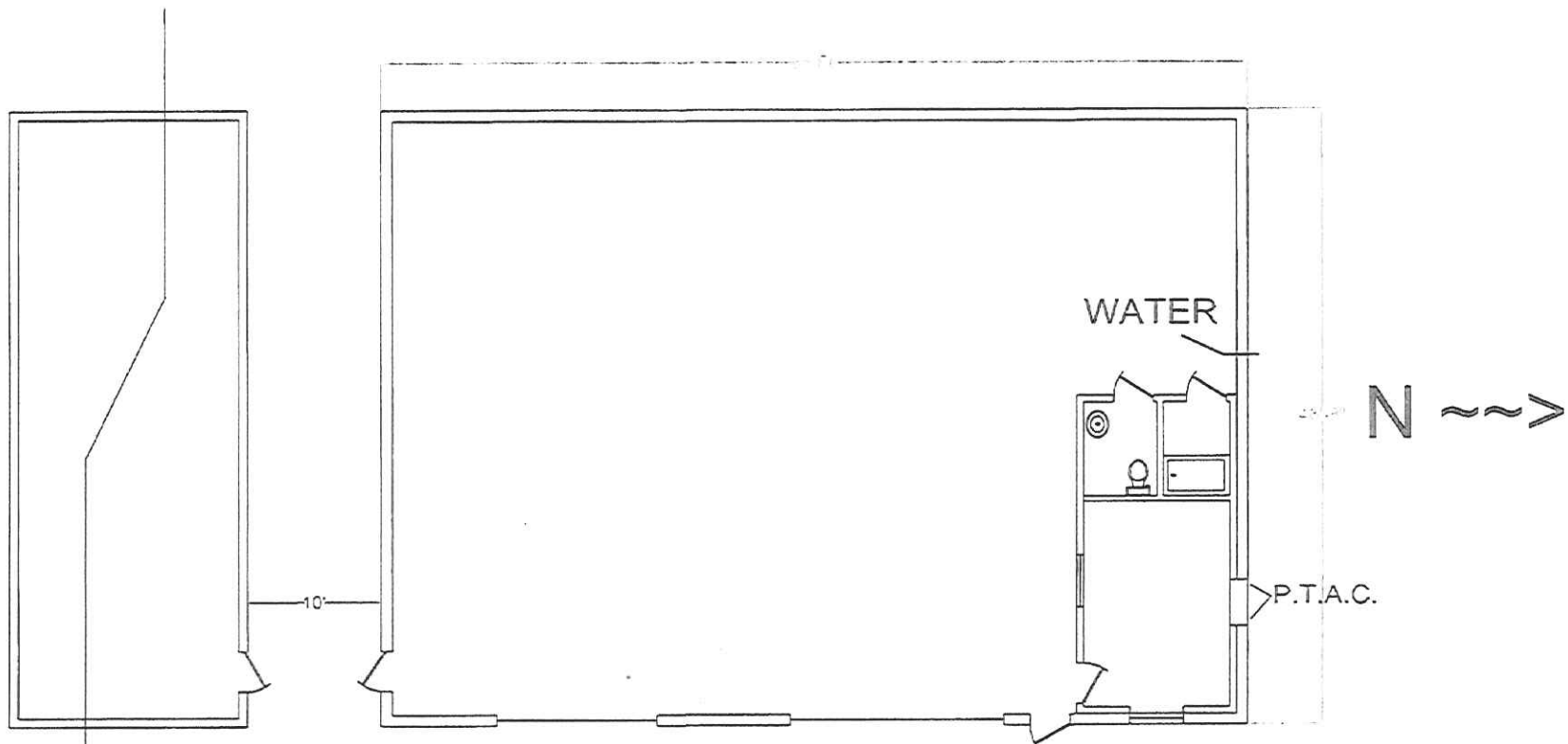

EXISTING BUILDING 100' LONG

FLOORPLAN WVDA DRAWINGS No.1

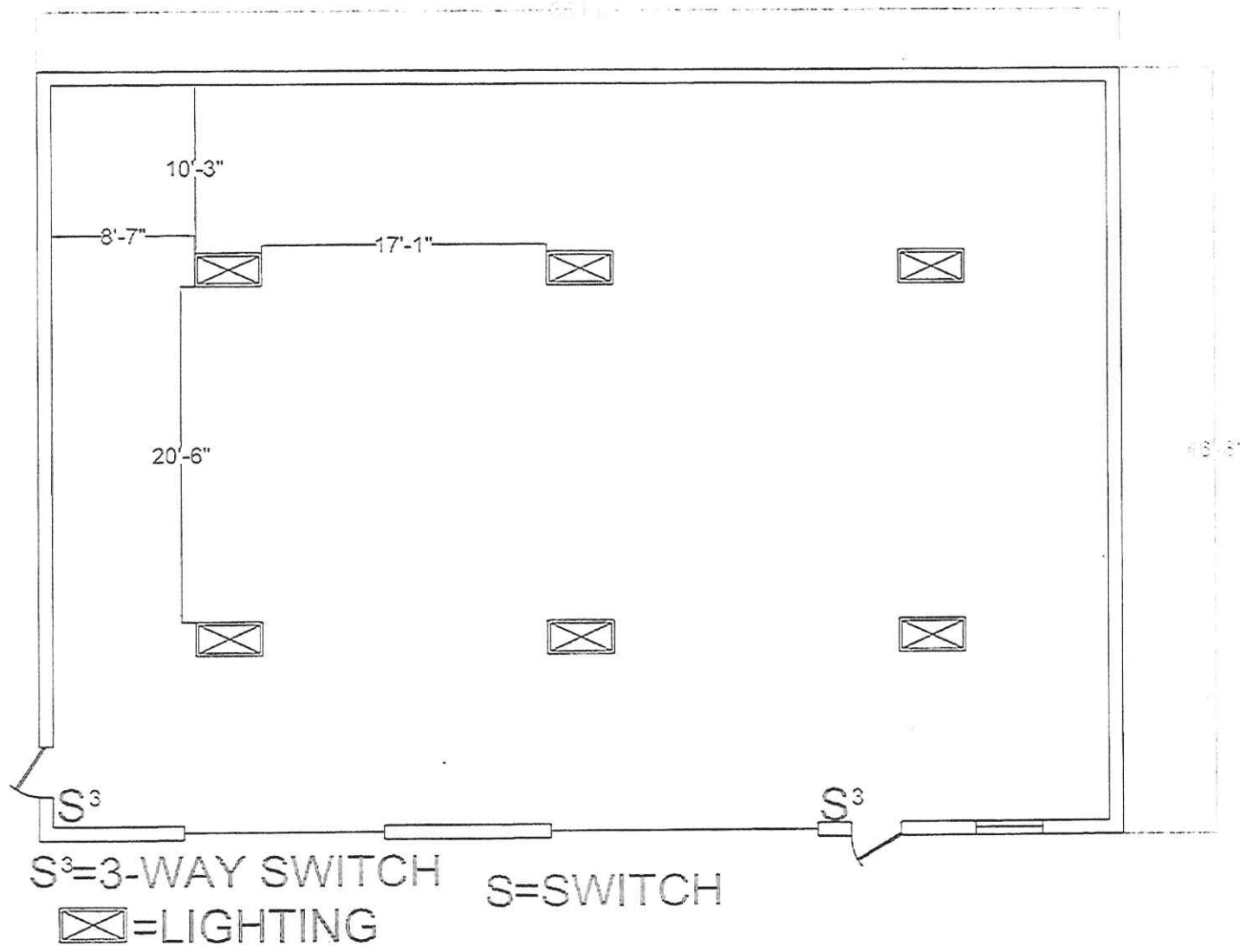
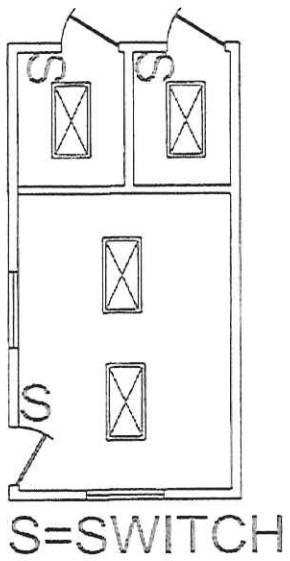

LIGHTING LAYOUT WVDA DRAWINGS No.3

# Front

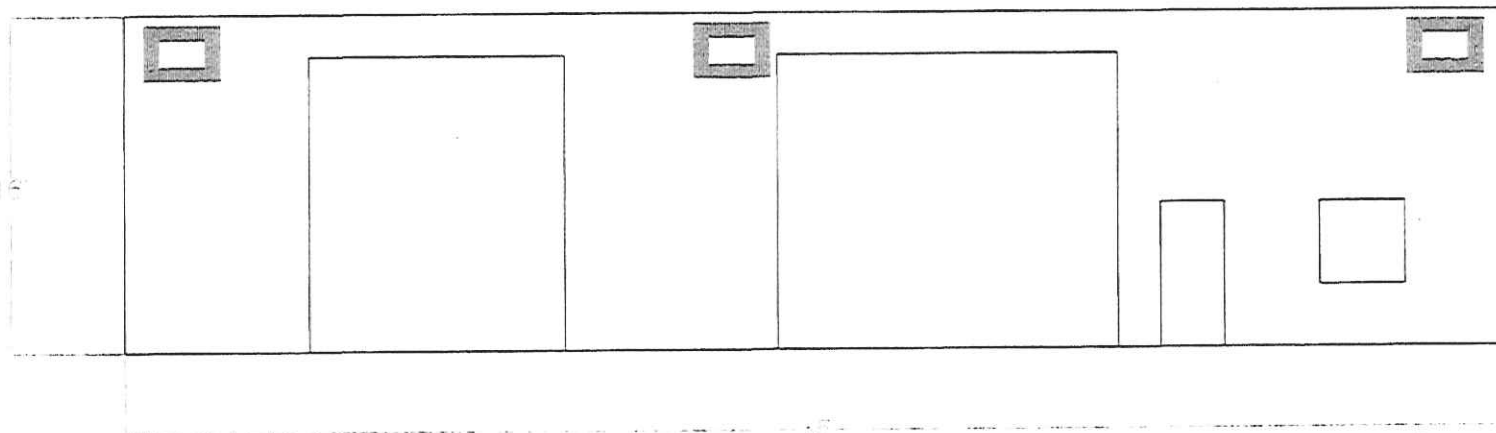

 = OUTSIDE LIGHTS

EAST WALL OUTSIDE LIGHTING WVDA DRAWINGS No.4

# Front

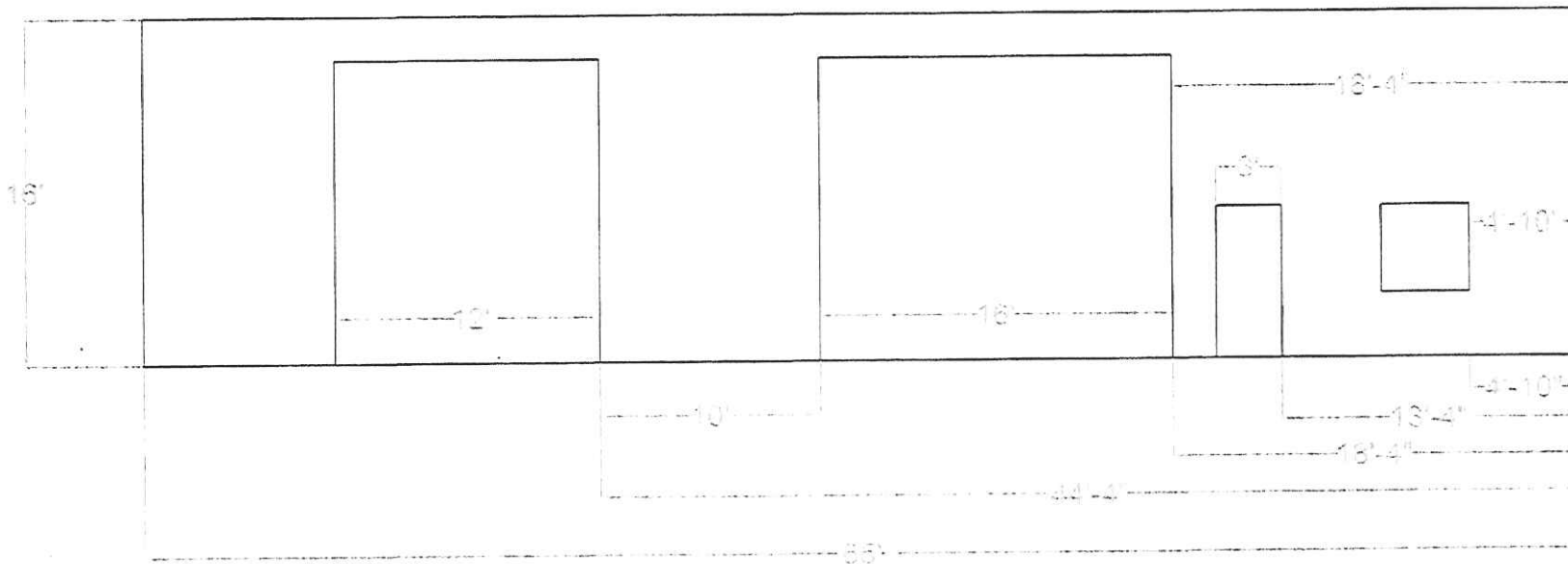

DIMENSIONS AND ELEVATION EAST WALL  
WVDA DRAWINGS No.5

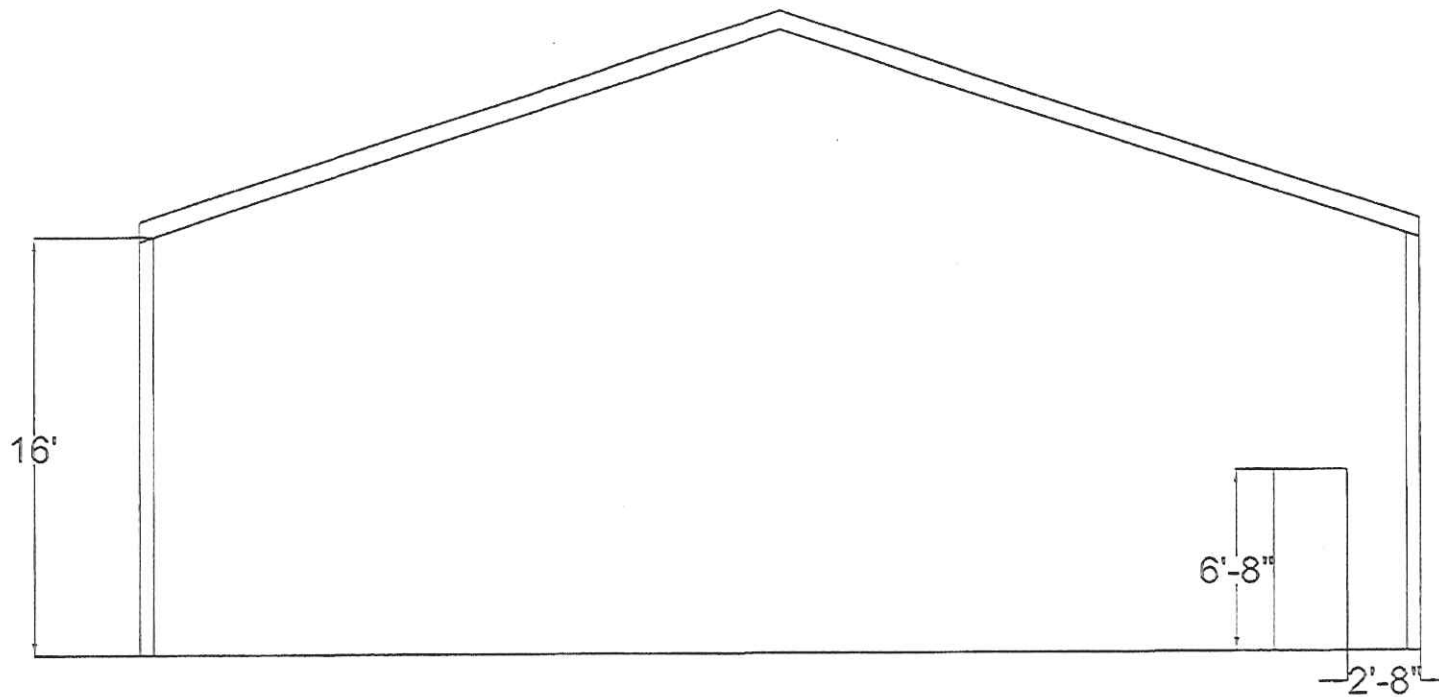

SOUTH WALL ELEVATION  
WVDA DRAWINGS No.6



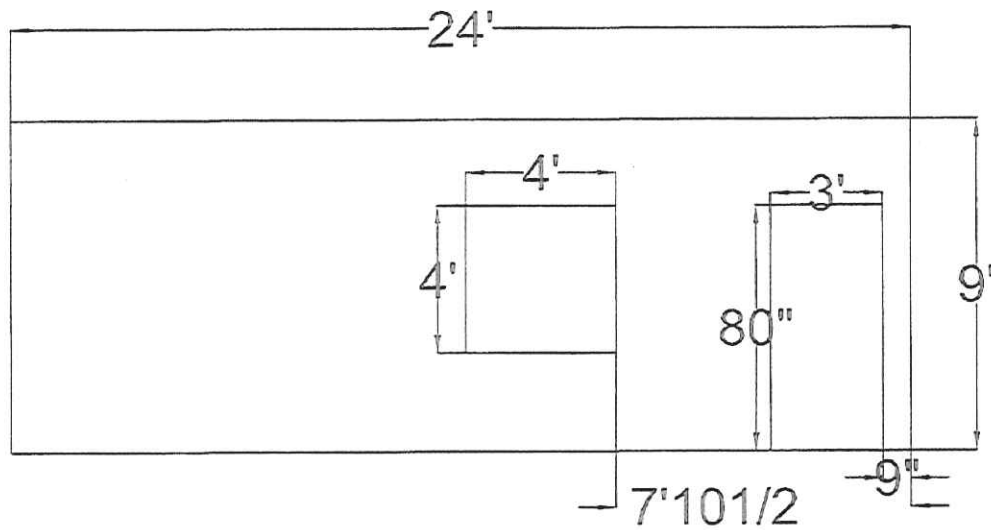

# OFFICE SOUTH WALL ELEVATION WVDA DRAWINGS No.7

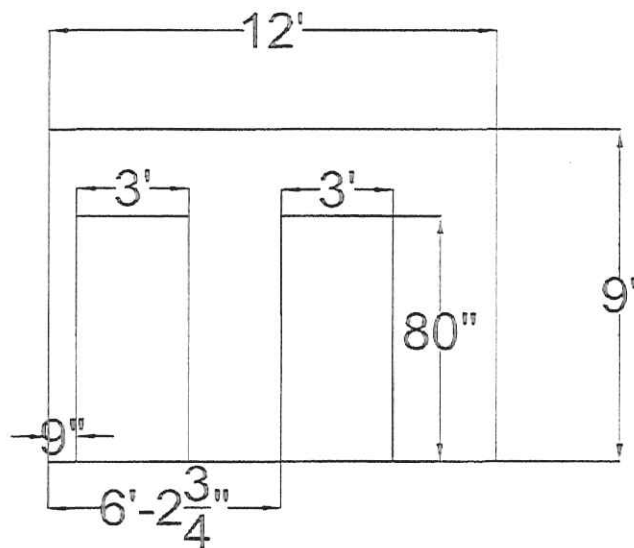

# OFFICE WEST WALL ELEVATION WVDA DRAWINGS No.8

PRICING PAGE AGR1332			
Item No.	Description	Quantity	Amount
1	Pre-Engineered Post Frame Office & Shop Building	1	\$348,000. <sup>00</sup>
	Failure to use this form may result in disqualification		
	<b>Bidder / Vendor Information</b>		
Name:	DANHILL CONSTRUCTION COMPANY		
Address:	P.O. Box 685		
	GAULEY BRIDGE, WV 25085		
Phone:	(304) 632-1600		
Email Address:	rdanhill@hotmail.com		
Authorized Signature:	Robert D. Hill		



State of West Virginia  
DRUG FREE WORKPLACE CONFORMANCE AFFIDAVIT  
West Virginia Code §21-1D-5

STATE OF West Virginia  
COUNTY OF Fayette, TO-WIT:

I, Robert D. Hill, after being first duly sworn, depose and state as follows:

- 1. I am an employee of Danhill Construction Company; and,  
(Company Name)
- 2. I do hereby attest that Danhill Construction Company  
(Company Name)

maintains a valid written drug free workplace policy and that such policy is in compliance with **West Virginia Code §21-1D-5**.

The above statements are sworn to under the penalty of perjury.

Danhill Construction Company  
(Company Name)

By: Robert D. Hill

Title: President

Date: 06/13/2013

Taken, subscribed and sworn to before me this 13 day of June 2013.

By Commission expires 3/28/2015



Jessica VanMeter  
(Notary Public)

**THIS AFFIDAVIT MUST BE SUBMITTED WITH THE BID IN ORDER TO COMPLY WITH WV CODE PROVISIONS. FAILURE TO INCLUDE THE AFFIDAVIT WITH THE BID SHALL RESULT IN DISQUALIFICATION OF THE BID.**

RFQ No. AGR1332

STATE OF WEST VIRGINIA  
Purchasing Division

**PURCHASING AFFIDAVIT**

**MANDATE:** Under W. Va. Code §5A-3-10a, no contract or renewal of any contract may be awarded by the state or any of its political subdivisions to any vendor or prospective vendor when the vendor or prospective vendor or a related party to the vendor or prospective vendor is a debtor and: (1) the debt owed is an amount greater than one thousand dollars in the aggregate; or (2) the debtor is in employer default.

**EXCEPTION:** The prohibition listed above does not apply where a vendor has contested any tax administered pursuant to chapter eleven of the W. Va. Code, workers' compensation premium, permit fee or environmental fee or assessment and the matter has not become final or where the vendor has entered into a payment plan or agreement and the vendor is not in default of any of the provisions of such plan or agreement.

**DEFINITIONS:**

"Debt" means any assessment, premium, penalty, fine, tax or other amount of money owed to the state or any of its political subdivisions because of a judgment, fine, permit violation, license assessment, defaulted workers' compensation premium, penalty or other assessment presently delinquent or due and required to be paid to the state or any of its political subdivisions, including any interest or additional penalties accrued thereon.

"Employer default" means having an outstanding balance or liability to the old fund or to the uninsured employers' fund or being in policy default, as defined in W. Va. Code § 23-2c-2, failure to maintain mandatory workers' compensation coverage, or failure to fully meet its obligations as a workers' compensation self-insured employer. An employer is not in employer default if it has entered into a repayment agreement with the Insurance Commissioner and remains in compliance with the obligations under the repayment agreement.

"Related party" means a party, whether an individual, corporation, partnership, association, limited liability company or any other form or business association or other entity whatsoever, related to any vendor by blood, marriage, ownership or contract through which the party has a relationship of ownership or other interest with the vendor so that the party will actually or by effect receive or control a portion of the benefit, profit or other consideration from performance of a vendor contract with the party receiving an amount that meets or exceeds five percent of the total contract amount.

**AFFIRMATION:** By signing this form, the vendor's authorized signer affirms and acknowledges under penalty of law for false swearing (W. Va. Code §61-5-3) that neither vendor nor any related party owe a debt as defined above and that neither vendor nor any related party are in employer default as defined above, unless the debt or employer default is permitted under the exception above.

**WITNESS THE FOLLOWING SIGNATURE:**

Vendor's Name: Danhill Construction Company  
Authorized Signature: Robert D. Hill Date: 6/13/2013

State of West Virginia

County of Fayette, to-wit:

Taken, subscribed, and sworn to before me this 13 day of June, 2013

My Commission expires March 28, 2015.

**AFFIX SEAL HERE**

**NOTARY PUBLIC**

Jessica VanMeter  
Purchasing Affidavit (Revised 07/01/2012)



CERTIFICATION AND SIGNATURE PAGE

By signing below, I certify that I have reviewed this Solicitation in its entirety; understand the requirements, terms and conditions, and other information contained herein; that I am submitting this bid or proposal for review and consideration; that I am authorized by the bidder to execute this bid or any documents related thereto on bidder's behalf; that I am authorized to bind the bidder in a contractual relationship; and that to the best of my knowledge, the bidder has properly registered with any State agency that may require registration.

Danhill Construction Company  
(Company)

Robert D. Hill  
(Authorized Signature)

Robert D. Hill, President  
(Representative Name, Title)

304-632-1600      304-632-1501  
(Phone Number)      (Fax Number)

June 13 2013  
(Date)

**ADDENDUM ACKNOWLEDGEMENT FORM**  
**SOLICITATION NO.:** AGR1332

**Instructions:** Please acknowledge receipt of all addenda issued with this solicitation by completing this addendum acknowledgment form. Check the box next to each addendum received and sign below. Failure to acknowledge addenda may result in bid disqualification.

**Acknowledgment:** I hereby acknowledge receipt of the following addenda and have made the necessary revisions to my proposal, plans and/or specification, etc.

**Addendum Numbers Received:**

(Check the box next to each addendum received)

- |  |  |
|--|--|
| <input checked="" type="checkbox"/> Addendum No. 1 | <input type="checkbox"/> Addendum No. 6  |
| <input checked="" type="checkbox"/> Addendum No. 2 | <input type="checkbox"/> Addendum No. 7  |
| <input type="checkbox"/> Addendum No. 3            | <input type="checkbox"/> Addendum No. 8  |
| <input type="checkbox"/> Addendum No. 4            | <input type="checkbox"/> Addendum No. 9  |
| <input type="checkbox"/> Addendum No. 5            | <input type="checkbox"/> Addendum No. 10 |

I understand that failure to confirm the receipt of addenda may be cause for rejection of this bid. I further understand that any verbal representation made or assumed to be made during any oral discussion held between Vendor's representatives and any state personnel is not binding. Only the information issued in writing and added to the specifications by an official addendum is binding.

Danhill Construction Company  
Company

Robert D. Hill  
Authorized Signature

June 13 2013  
Date

NOTE: This addendum acknowledgment should be submitted with the bid to expedite document processing.





State of West Virginia  
 Department of Administration  
 Purchasing Division  
 2019 Washington Street East  
 Post Office Box 50130  
 Charleston, WV 25305-0130

**Solicitation**

NUMBER
AGR1332

PAGE
1

ADDRESS CORRESPONDENCE TO ATTENTION OF:
GUY NISBET 304-558-8802

VENDOR

\*709053330      304-632-1558  
 DANHILL CONSTRUCTION COMPANY  
 PO BOX 685  
 GAULEY BRIDGE WV 25085

SHIP TO

DEPARTMENT OF AGRICULTURE  
 LAND SECTION/HUTTONSVILLE FARM  
 P.O. BOX 37  
 ROUTE 250 SOUTH  
 HUTTONSVILLE, WV  
 26273      304-558-2222

DATE PRINTED
05/28/2013

BID OPENING DATE: 06/13/2013      BID OPENING TIME 1:30PM

LINE	QUANTITY	UOP	CAT. NO.	ITEM NUMBER	UNIT PRICE	AMOUNT
ADDENDUM NO.1						
ADDENDUM FOR THE WEST VIRGINIA DEPT. OF AGRICULTURE POST AND FRAME BUILDING AT HUTTONSVILLE, WV. ISSUED TO PUBLISH THE PRE-BID MEETING SIGN IN SHEET, FROM THE MANDATORY MEETING HELD ON: MAY 21, 2013. AS ATTACHED.						
0001	1	LS		968-20		\$348,000.00
POST FRAME OFFICE AND SHOP BUILDING						
***** THIS IS THE END OF RFQ      AGR1332 ***** TOTAL:						\$348,000.00

SIGNATURE	<i>Robert D. Hill</i>	TELEPHONE	(304) 632-1600	DATE	6-13-2013
TITLE	PRESIDENT	FEIN	55-0648251	ADDRESS CHANGES TO BE NOTED ABOVE	

WHEN RESPONDING TO SOLICITATION, INSERT NAME AND ADDRESS IN SPACE ABOVE LABELED 'VENDOR'

SOLICITATION NUMBER: AGR1332  
 Addendum Number: No. 01

---

The purpose of this addendum is to modify the solicitation identified as ("Solicitation") to reflect the change(s) identified and described below.

**Applicable Addendum Category:**

- Modify bid opening date and time
- Modify specifications of product or service being sought
- Attachment of vendor questions and responses
- Attachment of pre-bid sign-in sheet
- Correction of error
- Other

**Description of Modification to Solicitation:**

1. Addendum for the West Virginia Dept. of Agriculture post and frame building at Huttonsville, WV. issued to publish the Pre-bid meeting sign in sheet, from the mandatory meeting held on: May 21, 2013. as attached.
2. Vendor question submittal s will be addressed in a later Addendum.
3. No other changes.

**Additional Documentation:** Documentation related to this Addendum (if any) has been included herewith as Attachment A and is specifically incorporated herein by reference.

**Terms and Conditions:**

1. All provisions of the Solicitation and other addenda not modified herein shall remain in full force and effect.
2. Vendor should acknowledge receipt of all addenda issued for this Solicitation by completing an Addendum Acknowledgment, a copy of which is included herewith. Failure to acknowledge addenda may result in bid disqualification. The addendum acknowledgement should be submitted with the bid to expedite document processing.

SIGN IN SHEET

Page \_\_\_\_\_ of \_\_\_\_\_

Request for Proposal No. \_\_\_\_\_

PLEASE PRINT

Date: \_\_\_\_\_

\* PLEASE BE SURE TO PRINT LEGIBLY - IF POSSIBLE, LEAVE A BUSINESS CARD

TELEPHONE & FAX NUMBERS

FIRM & REPRESENTATIVE NAME	MAILING ADDRESS	PHONE
Company: <u>FLINT CONSTRUCTION Co</u>	<u>PO Box 146</u>	<u>304-364-5555</u>
Rep: <u>ROB FLINT</u>	<u>GASSAWAY WV 26624</u>	TOLL FREE
Email Address: <u>Rob@flintconstructionco.com</u>		FAX <u>304-364-5556</u>
Company: <u>Range Contracting, LLC</u>	<u>195 Sunflower St.</u>	PHONE <u>304-952-7183</u>
Rep: <u>Travis L. Harry</u>	<u>Princeton, WV 24739</u>	TOLL FREE
Email Address: <u>tharry@rangecontracting.com</u>		FAX <u>304-325-5171</u>
Company: <u>Kyle Construction Co</u>		PHONE <u>304-872-2870</u>
Rep: <u>Ken Kyle</u>		TOLL FREE
Email Address: <u>K.Kyle.41@gmail.com</u>		FAX <u>304-872-5640</u>
Company: <u>PEARL GATE</u>	<u>7 Anchor Way</u>	PHONE <u>304-539-8999</u>
Rep: <u>John Brown</u>	<u>Winfield WV</u>	TOLL FREE
Email Address: <u>CB.Brown10@Yahoo.com</u>	<u>25213</u>	FAX <u>304-755-4885</u>
Company: <u>G.A. BROWN &amp; SON Inc.</u>	<u>215 Mill St.</u>	PHONE <u>304-363-4500</u>
Rep: <u>Roger Fletcher</u>	<u>Fairmont WV.</u>	TOLL @ Cell <u>304-276-5074</u>
Email Address: <u>RogFletcher@AOL.com</u>		FAX <u>304-366-9456</u>

or ~~John~~ @gabrown.com  
jbrown



State of West Virginia  
 Department of Administration  
 Purchasing Division  
 2019 Washington Street East  
 Post Office Box 50130  
 Charleston, WV 25305-0130

**Solicitation**

NUMBER
AGR1332

PAGE
1

ADDRESS CORRESPONDENCE TO ATTENTION OF:
GUY NISBET 304-558-8802

VENDOR

\*709053330      304-632-1558  
 DANHILL CONSTRUCTION COMPANY  
 PO BOX 685  
 GAULEY BRIDGE WV 25085

SHIP TO

DEPARTMENT OF AGRICULTURE  
 LAND SECTION/HUTTONSVILLE FARM  
 P.O. BOX 37  
 ROUTE 250 SOUTH  
 HUTTONSVILLE, WV  
 26273      304-558-2222

DATE PRINTED
05/30/2013

BID OPENING DATE: 06/13/2013      BID OPENING TIME 1:30PM

LINE	QUANTITY	UOP	CAT. NO.	ITEM NUMBER	UNIT PRICE	AMOUNT
ADDENDUM NO.2						
ADDENDUM FOR THE WEST VIRGINIA DEPT. OF AGRICULTURE POST AND FRAME BUILDING AT HUTTONSVILLE, WV. ISSUED TO PUBLISH THE VENDOR SUBMITTED QUESTIONS AND THE AGENCY RESPONSES TO THOSE QUESTIONS.						
0001	1	LS	968-20	POST FRAME OFFICE AND SHOP BUILDING		\$ 348,000. <sup>00</sup>
***** THIS IS THE END OF RFQ      AGR1332 ***** TOTAL:						\$ 348,000. <sup>00</sup>

SIGNATURE <i>Robert D. Hill</i>	TELEPHONE (304)632-1600	DATE 6-13-2013
TITLE PRESIDENT	FEIN 55-0648251	ADDRESS CHANGES TO BE NOTED ABOVE

WHEN RESPONDING TO SOLICITATION, INSERT NAME AND ADDRESS IN SPACE ABOVE LABELED 'VENDOR'

SOLICITATION NUMBER: AGR1332  
Addendum Number: No. 02

---

The purpose of this addendum is to modify the solicitation identified as ("Solicitation") to reflect the change(s) identified and described below.

**Applicable Addendum Category:**

- Modify bid opening date and time
- Modify specifications of product or service being sought
- Attachment of vendor questions and responses
- Attachment of pre-bid sign-in sheet
- Correction of error
- Other

**Description of Modification to Solicitation:**

1. Addendum for the West Virginia Dept. of Agriculture's Post and Frame building at the Huttonsville site, issued to publish the vendor submitted questions and the agency responses to those questions.
2. No other changes.

**Additional Documentation:** Documentation related to this Addendum (if any) has been included herewith as Attachment A and is specifically incorporated herein by reference.

**Terms and Conditions:**

1. All provisions of the Solicitation and other addenda not modified herein shall remain in full force and effect.
2. Vendor should acknowledge receipt of all addenda issued for this Solicitation by completing an Addendum Acknowledgment, a copy of which is included herewith. Failure to acknowledge addenda may result in bid disqualification. The addendum acknowledgement should be submitted with the bid to expedite document processing.

# ATTACHMENT A

A.9.Yes

10. Is there any base trim or cove base required in the office, restroom and shower room where the walls meet the floor?

A.10.Yes cove base dark green

11. With the engineering required and the current schedules of most building manufacturers; will the owner consider changing the 90 days to completion to 120 days?

A.11.Yes 120 days from notice to proceed

12. This building has been specified as a pre-engineered post frame (wood frame) building. Is an all steel frame building acceptable?

A.12.Yes as long as it meets all insulation requirements total R value of 25.

13. Will 7ft tall man doors be acceptable for the building and office area?

A.13.yes

14. The specifications only state shop doors are needed. Will these doors need to be regular overhead doors or drum doors?

A.14.drum

15. The new shop building can be constructed by either a "Pole Barn (wood framed)" or "Pre-Engineered Steel Building" method. Will you confirm this?

A.15.yes

16. Permanent electrical service will be brought to the corner of the existing slab, at the existing light pole. The contractor will then, tie into the power at this point. Will you confirm this?

A.16.yes

17. The existing concrete slab is 6" – 8" thick or greater. Will you confirm the thickness of this slab?

A.17.6 inches

18. Is there a footer located around the perimeter of the existing slab? If there is, what are the known dimensions of this footer?

A.18.Yes on the west wall footer dimension unknown



19. The existing slab appears to be in poor condition, with numerous changes in elevation throughout the new shop area. In order to provide a level construction surface (and overall better appearance of the final product), will the contractor be allowed to pour a short perimeter

ring wall (approximately 1" – 4" thick), the width of the bottom seal plate or steel column base plate, on the surface of the existing slab?

A.19.Yes

20. The walls of the new shop area are to be 6" thick. Will you confirm this?

A.20.Yes

21. Will the outside facing wall (where the exterior window is located on the steel building) of the office area, need to be framed, insulated, and dry walled? Or will this wall consist of the new steel siding from the shop area?

A.21.drywall

22. The exterior siding is to be hunter green, and the doors are to be white. Will you confirm this?

A.22.yes

23. The pitch of this building will match that of the existing building, at 4:12. Will you confirm this?

A.23.yes

24. Is there a possibility, the deadline will be extended out to 120 days from NTP?

A.24.yes 120 days

25. How long after the bid opening date, will the awarded contractor receive a NTP (notice to proceed)?

A.25. once contract is awarded.

26. My supplier said that the CertainTeed Bet-17 lay-in tiles require another number to determine exactly what you want. She said CertainTeed Ceiling Panels are 3 numbers not 2. Can you clarify?

A.26 CertainTeed Bet197 or equal

27. Are there any liquidated damages?

A.27.no

28. Does the shop area require HVAC?

A.28.NO

29. Is there any flooring in the restrooms or office area?

A.29.no

30 .Does the meter socket get mounted on the existing power pole or the proposed building?

A.30.proposed building as per the power company

31. If we are using the existing power pole, is it our responsibility to install the meter socket and riser on that pole with a disconnect and then feed the building underground from that service?

A.31.see item 30 also we will install a new approved pole as per the power company.

32. Where is the main panel box to be located?

A.32. office

33. Agricultural buildings not used for retail purposes do not have to comply with International Code. If this is a requirement wanted, the wall that is 10' from the existing building will have to be 1 hour rated and the door a 90 minute rating. Please advise

A.33. use current 10' spec

34. It was discussed possibly changing the completion days from 90 to 120. Will it be 90 or 120 days?

A.34. 120 days

35. What is the agency's recommendation for leveling the seal plate to the unlevel existing concrete?

A.35.see question 19 for answer

36. What does the pitch of the new roof need to be in order to match the existing building?

A.36. 4:12

37. What is the thickness of the concrete floor where the building post will set?

A.37. 6 inches

In the event the owner will accept an all steel building;

38. The owner's specifications call for steel liner to be installed at the bottom chords of the roof trusses. There is no practical way to install a level ceiling in a typical steel frame building. If an all steel building; is it acceptable for the steel liner to be installed on the roof-slope at the underside of the roof purlins?

A.38.yes as long as the same R value spec is met

39. The post frame building is specified as 16' clear from the top of the existing concrete slab to the bottom of the roof trusses. If an all steel building; is 16' required at the eave-line or at the haunch? (at the haunch is the height from the top of the existing concrete slab to the underside of an intermediate frame where the rafter and column connect.

A.39.at the haunch

**BID BOND**

KNOW ALL MEN BY THESE PRESENTS, That we, the undersigned, Danhill Construction Company  
of Gauley Bridge, West Virginia, as Principal, and Colonial Surety Co. of  
Montvale, New Jersey, a corporation organized and existing under the laws of the State of NJ with its  
principal office in the City of Montvale, as Surety, are held and firmly bound unto the State of West Virginia, as Obligee, in the  
penal sum of 5 % Of Bid Amount (\$ 5% ) for the payment of which, well and truly to be made, we jointly and  
severally bind ourselves, our heirs, administrators, executors, successors and assigns.

The Condition of the above obligation is such that whereas the Principal has submitted to the Purchasing Section of the  
Department of Administration a certain bid or proposal, attached hereto and made a part hereof, to enter into a contract in writing for  
Construction of Pol Building at Agriculture Farm in Huttonsville, WV

NOW THEREFORE,

- (a) If said bid shall be rejected, or
- (b) If said bid shall be accepted and the Principal shall enter into a contract in accordance with the bid or proposal attached  
hereto and shall furnish any other bonds and insurance required by the bid or proposal, and shall in all other respects perform the  
agreement created by the acceptance of said bid, then this obligation shall be null and void, otherwise this obligation shall remain in full  
force and effect. It is expressly understood and agreed that the liability of the Surety for any and all claims hereunder shall, in no event,  
exceed the penal amount of this obligation as herein stated.

The Surety, for the value received, hereby stipulates and agrees that the obligations of said Surety and its bond shall be in no  
way impaired or affected by any extension of the time within which the Obligee may accept such bid, and said Surety does hereby  
waive notice of any such extension.

IN WITNESS WHEREOF, Principal and Surety have hereunto set their hands and seals, and such of them as are corporations  
have caused their corporate seals to be affixed hereunto and these presents to be signed by their proper officers, this  
13<sup>th</sup> day of June, 20 13.

Principal Corporate Seal

Danhill Construction Company  
(Name of Principal)  
By Robert D. Hill *Robert D. Hill*  
(Must be President or  
Vice President)  
President  
(Title)

Surety Corporate Seal

Colonial Surety company  
(Name of Surety)  
Roberta Bird *Roberta Bird*  
Attorney-in-Fact

**IMPORTANT – Surety executing bonds must be licensed in West Virginia to transact surety insurance. Raised corporate seals  
must be affixed, a power of attorney must be attached.**

COLONIAL SURETY COMPANY

Duncannon, Pennsylvania
Administrative Office: 50 Chestnut Ridge Road, Montvale, New Jersey 07645

GENERAL POWER OF ATTORNEY

Know all Men by These Presents, That COLONIAL SURETY COMPANY, a corporation duly organized and existing under the laws of the Commonwealth of Pennsylvania and having an administrative office in Montvale, Bergen County, NJ does by these presents make, constitute and appoint

Wayne Nunziata or Anthony J. Cimasko or Audie B. Murphy of Montvale and the State of New Jersey its true and lawful Attorney(s)-in-Fact, with full power and authority hereby conferred in its name, place and stead, to execute, acknowledge and deliver.

Any and All Bonds

and to bind the Company thereby as fully and to the same extent as if such bonds were signed by the President, sealed with the corporate seal of the Company and duly attested by its Secretary, hereby ratifying and confirming all that the said Attorney(s)-in-Fact may do in the premises.

Be it Resolved, that the President, any Vice-President, any Secretary or any Assistant Secretary shall be and is hereby vested with full power and authority to appoint any one or more suitable persons as Attorney(s)-in-Fact to represent and act for and on behalf of the Company subject to the following provisions:

Section 1. Attorney-in-Fact. Attorney-in-Fact may be given full power and authority for and in the name of and on behalf of the Company, to execute, acknowledge and deliver, any and all bonds, recognizances, contracts, agreements of indemnity and other conditional or obligatory undertakings and any and all notices and documents canceling or terminating the Company's liability thereunder, and any such instruments so executed by any such Attorney-in-Fact shall be binding upon the Company as if signed by the President and sealed and attested by the Corporate Secretary.

In Witness Whereof, Colonial Surety Company has caused these presents to be signed by its President and its corporate seal to be hereto affixed the 27th day of April, A.D., 2011.



COLONIAL SURETY COMPANY

By Wayne Nunziata, President

State of New Jersey }
County of Bergen } SS.:

On this 27th day of April, in the year 2011, before me Theresa Spinelli, a notary public, personally appeared Wayne Nunziata, personally known to me to be the person who executed the within instrument as President, on behalf of the corporation therein named and acknowledged to me that the corporation executed it.



THERESA SPINELLI
A Notary Public of New Jersey
My Commission Expires September 9, 2015

Theresa Spinelli, Notary Public

I, the undersigned Secretary of Colonial Surety Company, hereby certify that the above and foregoing is a full, true and correct copy of the Original Power of Attorney issued by said Company, and do hereby further certify that the said Power of Attorney is still in force and effect.

And I do hereby further certify that the Certification of this Power of Attorney is signed and sealed by facsimile under and by the authority of the following resolution adopted by the Board of Directors of the Colonial Surety Company at a meeting duly called and held on the 30th of January 1968, and that said resolution has not been amended or repealed:

RESOLVED, that the signature of the Secretary or any Assistant Secretary of this Corporation, and the seal of Corporation, may be affixed or printed by facsimile to any certificate to a Power of Attorney of this Corporation, and that such printed facsimile signature and seal shall be valid and binding upon this Corporation.

GIVEN under my hand and the seal of said Company, at Montvale, New Jersey this 13th day of June, 2013.

Original printed with Blue and Black ink. For verification of the authenticity of this Power of Attorney you may call (201) 573-8788 and ask for the Power of Attorney clerk. Please refer to the above named individual(s) and details of the bond to which the power is attached.

Audie B. Murphy, Secretary



# CONTRACTOR LICENSE

Authorized by the

## West Virginia Contractor Licensing Board

**Number:** WV001196

**Classification:**

ELECTRICAL  
GENERAL BUILDING  
HEATING, VENTILATING & COOLING  
MULTIFAMILY  
PIPING  
PLUMBING  
RESIDENTIAL

DANHILL CONSTRUCTION COMPANY  
DBA DANHILL CONSTRUCTION COMPANY  
PO BOX 685  
GAULEY BRIDGE, WV 25085-0685

**Date Issued**

AUGUST 06, 2012

**Expiration Date**

AUGUST 06, 2013



Authorized Company Signature



Chair, West Virginia Contractor  
Licensing Board



WEST VIRGINIA  
CONTRACTOR  
LICENSING  
BOARD

This license, or a copy thereof, must be posted in a conspicuous place at every construction site where work is being performed. This license number must appear in all advertisements, on all bid submissions and on all fully executed and binding contracts. This license cannot be assigned or transferred by licensee. Issued under provisions of West Virginia Code, Chapter 21, Article 11.





# CERTIFICATE OF LIABILITY INSURANCE

DANCO02

OP ID: BO

DATE (MM/DD/YYYY)

07/10/12

THIS CERTIFICATE IS ISSUED AS A MATTER OF INFORMATION ONLY AND CONFERS NO RIGHTS UPON THE CERTIFICATE HOLDER. THIS CERTIFICATE DOES NOT AFFIRMATIVELY OR NEGATIVELY AMEND, EXTEND OR ALTER THE COVERAGE AFFORDED BY THE POLICIES BELOW. THIS CERTIFICATE OF INSURANCE DOES NOT CONSTITUTE A CONTRACT BETWEEN THE ISSUING INSURER(S), AUTHORIZED REPRESENTATIVE OR PRODUCER, AND THE CERTIFICATE HOLDER.

**IMPORTANT:** If the certificate holder is an ADDITIONAL INSURED, the policy(ies) must be endorsed. If SUBROGATION IS WAIVED, subject to the terms and conditions of the policy, certain policies may require an endorsement. A statement on this certificate does not confer rights to the certificate holder in lieu of such endorsement(s).

<b>PRODUCER</b> Jim Lively Insurance PO Box 1633 631 Jones Ave. Oak Hill, WV 25901	304-465-5885	<b>CONTACT NAME:</b> _____ <b>PHONE (A/C, No, Ext):</b> 304-465-1490	<b>FAX (A/C, No):</b> _____
	<b>E-MAIL ADDRESS:</b> _____		
		<b>INSURER(S) AFFORDING COVERAGE</b>	<b>NAIC #</b>
		<b>INSURER A: State Auto Group</b>	<b>25135</b>
		<b>INSURER B:</b> _____	
		<b>INSURER C:</b> _____	
		<b>INSURER D:</b> _____	
		<b>INSURER E:</b> _____	
		<b>INSURER F:</b> _____	

**INSURED** Danhill Construction Co.  
 PO Box 685  
 Gauley Bridge, WV 25085

**COVERAGES**                      **CERTIFICATE NUMBER:**                      **REVISION NUMBER:**

THIS IS TO CERTIFY THAT THE POLICIES OF INSURANCE LISTED BELOW HAVE BEEN ISSUED TO THE INSURED NAMED ABOVE FOR THE POLICY PERIOD INDICATED. NOTWITHSTANDING ANY REQUIREMENT, TERM OR CONDITION OF ANY CONTRACT OR OTHER DOCUMENT WITH RESPECT TO WHICH THIS CERTIFICATE MAY BE ISSUED OR MAY PERTAIN, THE INSURANCE AFFORDED BY THE POLICIES DESCRIBED HEREIN IS SUBJECT TO ALL THE TERMS, EXCLUSIONS AND CONDITIONS OF SUCH POLICIES. LIMITS SHOWN MAY HAVE BEEN REDUCED BY PAID CLAIMS.

INSR LTR	TYPE OF INSURANCE	ADDL INSR	SUBR WVD	POLICY NUMBER	POLICY EFF (MM/DD/YYYY)	POLICY EXP (MM/DD/YYYY)	LIMITS
A	<b>GENERAL LIABILITY</b>			PBP2567918 02	07/01/12	07/01/13	EACH OCCURRENCE \$ 1,000,000
	<input checked="" type="checkbox"/> COMMERCIAL GENERAL LIABILITY						DAMAGE TO RENTED PREMISES (Ea occurrence) \$ 100,000
	<input type="checkbox"/> CLAIMS-MADE <input checked="" type="checkbox"/> OCCUR						MED EXP (Any one person) \$ 5,000
	<input checked="" type="checkbox"/> EPLI						PERSONAL & ADV INJURY \$ 1,000,000
	GEN'L AGGREGATE LIMIT APPLIES PER:						GENERAL AGGREGATE \$ 2,000,000
	<input type="checkbox"/> POLICY <input type="checkbox"/> PRO-JECT <input type="checkbox"/> LOC						PRODUCTS - COM/POP AGG \$ 2,000,000
	<b>AUTOMOBILE LIABILITY</b>						COMBINED SINGLE LIMIT (Ea accident) \$
	<input type="checkbox"/> ANY AUTO						BODILY INJURY (Per person) \$
	<input type="checkbox"/> ALL OWNED AUTOS		<input type="checkbox"/> SCHEDULED AUTOS				BODILY INJURY (Per accident) \$
	<input type="checkbox"/> HIRED AUTOS		<input type="checkbox"/> NON-OWNED AUTOS				PROPERTY DAMAGE (Per accident) \$
	<input type="checkbox"/> UMBRELLA LIAB		<input type="checkbox"/> OCCUR				EACH OCCURRENCE \$
	<input type="checkbox"/> EXCESS LIAB		<input type="checkbox"/> CLAIMS-MADE				AGGREGATE \$
	<input type="checkbox"/> DED <input type="checkbox"/> RETENTION \$						\$
	<b>WORKERS COMPENSATION AND EMPLOYERS' LIABILITY</b>						WC STATU-TORY LIMITS <input type="checkbox"/> OTH-ER <input type="checkbox"/>
	ANY PROPRIETOR/PARTNER/EXECUTIVE OFFICER/MEMBER EXCLUDED? (Mandatory in NH)		<input type="checkbox"/> Y <input type="checkbox"/> N	N/A			E.L. EACH ACCIDENT \$
	If yes, describe under DESCRIPTION OF OPERATIONS below						E.L. DISEASE - EA EMPLOYEE \$
							E.L. DISEASE - POLICY LIMIT \$

DESCRIPTION OF OPERATIONS / LOCATIONS / VEHICLES (Attach ACORD 101, Additional Remarks Schedule, if more space is required)

**CERTIFICATE HOLDER****CANCELLATION**

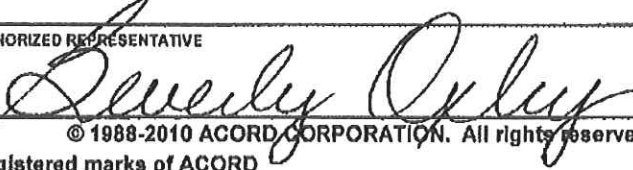
SELF000  <b>CERTIFICATE FOR INSURED'S RECORDS</b> WV	SHOULD ANY OF THE ABOVE DESCRIBED POLICIES BE CANCELLED BEFORE THE EXPIRATION DATE THEREOF, NOTICE WILL BE DELIVERED IN ACCORDANCE WITH THE POLICY PROVISIONS.  AUTHORIZED REPRESENTATIVE 
---	---

© 1988-2010 ACORD CORPORATION. All rights reserved.



DANCO02

OP ID: BO

# CERTIFICATE OF LIABILITY INSURANCE

DATE (MM/DD/YYYY)

11/27/2012

THIS CERTIFICATE IS ISSUED AS A MATTER OF INFORMATION ONLY AND CONFERS NO RIGHTS UPON THE CERTIFICATE HOLDER. THIS CERTIFICATE DOES NOT AFFIRMATIVELY OR NEGATIVELY AMEND, EXTEND OR ALTER THE COVERAGE AFFORDED BY THE POLICIES BELOW. THIS CERTIFICATE OF INSURANCE DOES NOT CONSTITUTE A CONTRACT BETWEEN THE ISSUING INSURER(S), AUTHORIZED REPRESENTATIVE OR PRODUCER, AND THE CERTIFICATE HOLDER.

**IMPORTANT:** If the certificate holder is an ADDITIONAL INSURED, the policy(ies) must be endorsed. If SUBROGATION IS WAIVED, subject to the terms and conditions of the policy, certain policies may require an endorsement. A statement on this certificate does not confer rights to the certificate holder in lieu of such endorsement(s).

<b>PRODUCER</b> Jim Lively Insurance PO Box 1833 531 Jones Ave, Oak Hill, WV 26001	Phone: 304-465-5685 Fax: 304-465-1490	<b>CONTACT NAME:</b> PHONE (A/C, No, Ext): E-MAIL ADDRESS: FAX (A/C, No):																					
<b>INSURED</b> Danhill Construction Co. PO Box 885 Gauley Bridge, WV 25085		<table border="1" style="width: 100%; border-collapse: collapse;"> <tr> <th colspan="2" style="text-align: center;">INSURER(S) AFFORDING COVERAGE</th> <th style="text-align: center;">NAIC #</th> </tr> <tr> <td>INSURER A:</td> <td>BrickStreet Mutual Ins.</td> <td style="text-align: center;">12372 BC</td> </tr> <tr> <td>INSURER B:</td> <td></td> <td></td> </tr> <tr> <td>INSURER C:</td> <td></td> <td></td> </tr> <tr> <td>INSURER D:</td> <td></td> <td></td> </tr> <tr> <td>INSURER E:</td> <td></td> <td></td> </tr> <tr> <td>INSURER F:</td> <td></td> <td></td> </tr> </table>	INSURER(S) AFFORDING COVERAGE		NAIC #	INSURER A:	BrickStreet Mutual Ins.	12372 BC	INSURER B:			INSURER C:			INSURER D:			INSURER E:			INSURER F:		
INSURER(S) AFFORDING COVERAGE		NAIC #																					
INSURER A:	BrickStreet Mutual Ins.	12372 BC																					
INSURER B:																							
INSURER C:																							
INSURER D:																							
INSURER E:																							
INSURER F:																							

**COVERAGES**

CERTIFICATE NUMBER:

REVISION NUMBER:

THIS IS TO CERTIFY THAT THE POLICIES OF INSURANCE LISTED BELOW HAVE BEEN ISSUED TO THE INSURED NAMED ABOVE FOR THE POLICY PERIOD INDICATED. NOTWITHSTANDING ANY REQUIREMENT, TERM OR CONDITION OF ANY CONTRACT OR OTHER DOCUMENT WITH RESPECT TO WHICH THIS CERTIFICATE MAY BE ISSUED OR MAY PERTAIN, THE INSURANCE AFFORDED BY THE POLICIES DESCRIBED HEREIN IS SUBJECT TO ALL THE TERMS, EXCLUSIONS AND CONDITIONS OF SUCH POLICIES. LIMITS SHOWN MAY HAVE BEEN REDUCED BY PAID CLAIMS.

LINE	TYPE OF INSURANCE	ADDITIONAL INSURER	SUBROGATION	POLICY NUMBER	POLICY EFF (MM/DD/YYYY)	POLICY EXP (MM/DD/YYYY)	LIMITS
PC 531	GENERAL LIABILITY						EACH OCCURRENCE \$
	<input type="checkbox"/> COMMERCIAL GENERAL LIABILITY <input type="checkbox"/> CLAIMS-MADE <input type="checkbox"/> OCCUR GEN'L AGGREGATE LIMIT APPLIES PER: <input type="checkbox"/> POLICY <input type="checkbox"/> PROJECT <input type="checkbox"/> LOC						DAMAGE TO RENTED PREMISES (Ea occurrence) \$ MED EXP (Any one person) \$ PERSONAL & ADV INJURY \$ GENERAL AGGREGATE \$ PRODUCTS - COMPROP AGG \$
A	AUTOMOBILE LIABILITY						COMBINED SINGLE LIMIT (Ea accident) \$ BODILY INJURY (Per person) \$ BODILY INJURY (Per accident) \$ PROPERTY DAMAGE (Per accident) \$
	<input type="checkbox"/> ANY AUTO <input type="checkbox"/> ALL OWNED AUTOS <input type="checkbox"/> HIRED AUTOS <input type="checkbox"/> SCHEDULED AUTOS <input type="checkbox"/> NON-OWNED AUTOS						ALL THE TERMS
A	UMBRELLA LIAB						EACH OCCURRENCE \$
	<input type="checkbox"/> EXCESS LIAB <input type="checkbox"/> OCCUR <input type="checkbox"/> CLAIMS-MADE DED RETENTION \$						AGGREGATE \$ \$
A	WORKERS COMPENSATION AND EMPLOYERS' LIABILITY						<input checked="" type="checkbox"/> WC STATUTORY LIMITS <input type="checkbox"/> OTHER
	<input type="checkbox"/> ANY PROPRIETOR/PARTNER/EXECUTIVE OFFICER/MEMBER EXCLUDED? (Mandatory in NH) If yes, describe under DESCRIPTION OF OPERATIONS below			WCB1008781	09/20/2012	09/20/2013	E.L. EACH ACCIDENT \$ 1,000,000 E.L. DISEASE - EA EMPLOYEE \$ 1,000,000 E.L. DISEASE - POLICY LIMIT \$ 1,000,000

DESCRIPTION OF OPERATIONS / LOCATIONS / VEHICLES (Attach ACORD 101, Additional Remarks Schedule, if more space is required)

**CERTIFICATE HOLDER****CANCELLATION**

SELF000

CERTIFICATE FOR INSURED'S RECORDS  
WV

SHOULD ANY OF THE ABOVE DESCRIBED POLICIES BE CANCELLED BEFORE THE EXPIRATION DATE THEREOF, NOTICE WILL BE DELIVERED IN ACCORDANCE WITH THE POLICY PROVISIONS.

AUTHORIZED REPRESENTATIVE

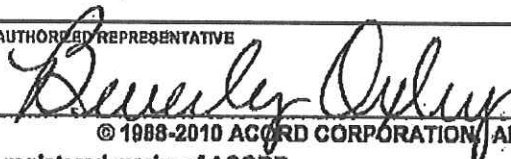

© 1988-2010 ACORD CORPORATION. All rights reserved.



# CERTIFICATE OF LIABILITY INSURANCE

DANCO02

OP ID: BO

DATE (MM/DD/YYYY)

11/27/2012

THIS CERTIFICATE IS ISSUED AS A MATTER OF INFORMATION ONLY AND CONFERS NO RIGHTS UPON THE CERTIFICATE HOLDER. THIS CERTIFICATE DOES NOT AFFIRMATIVELY OR NEGATIVELY AMEND, EXTEND OR ALTER THE COVERAGE AFFORDED BY THE POLICIES BELOW. THIS CERTIFICATE OF INSURANCE DOES NOT CONSTITUTE A CONTRACT BETWEEN THE ISSUING INSURER(S), AUTHORIZED REPRESENTATIVE OR PRODUCER, AND THE CERTIFICATE HOLDER.

**IMPORTANT:** If the certificate holder is an ADDITIONAL INSURED, the policy(ies) must be endorsed. If SUBROGATION IS WAIVED, subject to the terms and conditions of the policy, certain policies may require an endorsement. A statement on this certificate does not confer rights to the certificate holder in lieu of such endorsement(s).

<b>PRODUCER</b> Jim Lively Insurance PO, Box 1633 531 Jones Ave. Oak Hill, WV 25901	Phone: 304-466-6886 Fax: 304-466-1490	<b>CONTACT NAME:</b> _____	<b>FAX (A/C, No):</b> _____
		<b>PHONE (A/C, No, Ext):</b> _____	<b>E-MAIL ADDRESS:</b> _____
		<b>INSURER(S) AFFORDING COVERAGE</b>	
		<b>INSURER A:</b> Essex Insurance Company	<b>NAIC #:</b> _____
		<b>INSURER B:</b> _____	<b>NAIC #:</b> _____
		<b>INSURER C:</b> _____	<b>NAIC #:</b> _____
		<b>INSURER D:</b> _____	<b>NAIC #:</b> _____
		<b>INSURER E:</b> _____	<b>NAIC #:</b> _____
		<b>INSURER F:</b> _____	<b>NAIC #:</b> _____

**INSURED** Danhill Construction Co.  
 PO Box 686  
 Gauley Bridge, WV 25085

**COVERAGES**      **CERTIFICATE NUMBER:**      **REVISION NUMBER:**

THIS IS TO CERTIFY THAT THE POLICIES OF INSURANCE LISTED BELOW HAVE BEEN ISSUED TO THE INSURED NAMED ABOVE FOR THE PERIOD INDICATED. NOTWITHSTANDING ANY REQUIREMENT, TERM OR CONDITION OF ANY CONTRACT OR OTHER DOCUMENT WITH RESPECT TO WHICH THIS CERTIFICATE MAY BE ISSUED OR MAY PERTAIN, THE INSURANCE AFFORDED BY THE POLICIES DESCRIBED HEREIN IS SUBJECT TO ALL THE TERMS, EXCLUSIONS AND CONDITIONS OF SUCH POLICIES. LIMITS SHOWN MAY HAVE BEEN REDUCED BY PAID CLAIMS.

INSURER	TYPE OF INSURANCE	ADDL SUBR INSR	WVO	POLICY NUMBER	POLICY EFF (MM/DD/YYYY)	POLICY EXP (MM/DD/YYYY)	LIMITS
111	<b>GENERAL LIABILITY</b>						EACH OCCURRENCE \$ _____ DAMAGE TO RENTED PREMISES (Ea occurrence) \$ _____ MED EXP (Any one person) \$ _____ PERSONAL & ADV INJURY \$ _____ GENERAL AGGREGATE \$ _____ PRODUCTS - COM/PROP AGG \$ _____
	<input type="checkbox"/> COMMERCIAL GENERAL LIABILITY <input type="checkbox"/> CLAIMS-MADE <input type="checkbox"/> OCCUR						
	GEN'L AGGREGATE LIMIT APPLIES PER: <input type="checkbox"/> POLICY <input type="checkbox"/> PRO-JECT <input type="checkbox"/> LOC						
	<b>AUTOMOBILE LIABILITY</b> <input type="checkbox"/> ANY AUTO <input type="checkbox"/> ALL OWNED AUTOS <input type="checkbox"/> HIRED AUTOS <input type="checkbox"/> SCHEDULED AUTOS <input type="checkbox"/> NON-OWNED AUTOS						
111	<input type="checkbox"/> UMBRELLA LIAB <input type="checkbox"/> EXCESS LIAB						EACH OCCURRENCE \$ _____ AGGREGATE \$ _____
	<input type="checkbox"/> OCCUR <input type="checkbox"/> CLAIMS-MADE DED \$ _____ RETENTION \$ _____						
A	<b>WORKERS COMPENSATION AND EMPLOYERS' LIABILITY</b> ANY PROPRIETOR/PARTNER/EXECUTIVE OFFICER/MEMBER EXCLUDED? (Mandatory in NH) If yes, describe under DESCRIPTION OF OPERATIONS below	Y/N <input type="checkbox"/>	N/A	3DL2888 BROAD FORM	09/20/2012	09/20/2013	<input checked="" type="checkbox"/> WC STATUTORY LIMITS <input type="checkbox"/> OTHER E.L. EACH ACCIDENT \$ 1,000,000 E.L. DISEASE - EA EMPLOYEE \$ 1,000,000 E.L. DISEASE - POLICY LIMIT \$ 1,000,000

DESCRIPTION OF OPERATIONS / LOCATIONS / VEHICLES (Attach ACORD 101, Additional Remarks Schedule, if more space is required)

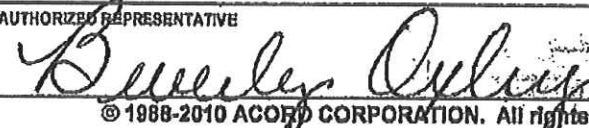
<b>CERTIFICATE HOLDER</b> SELF000 CERTIFICATE FOR INSURED'S RECORDS WV	<b>CANCELLATION</b> SHOULD ANY OF THE ABOVE DESCRIBED POLICIES BE CANCELLED BEFORE THE EXPIRATION DATE THEREOF, NOTICE WILL BE DELIVERED IN ACCORDANCE WITH THE POLICY PROVISIONS. AUTHORIZED REPRESENTATIVE 
---	--