



State of West Virginia  
 Department of Administration  
 Purchasing Division  
 2019 Washington Street East  
 Post Office Box 50130  
 Charleston, WV 25305-0130

**Solicitation**

NUMBER
7713005

PAGE
1

ADDRESS CORRESPONDENCE TO ATTENTION OF:
ALAN CUMMINGS 304-558-2402

VENDOR

RFQ COPY  
 TYPE NAME/ADDRESS HERE

SHIP TO

DIVISION OF HIGHWAYS  
 MCS&T DIVISION  
 190 DRY BRANCH DRIVE  
 CHARLESTON WV  
 25306 304-558-9892

DATE PRINTED
10/19/2012

BID OPENING DATE: 11/07/2012 BID OPENING TIME 1:30PM

LINE	QUANTITY	UOP	CAT. NO.	ITEM NUMBER	UNIT PRICE	AMOUNT
0001	1	LS		490-55	51,973.60	51,973.60
ICAP 6300 DUO VIEW ICP-OES SPECTROMETER OR EQUAL						
<p>THE WEST VIRGINIA STATE PURCHASING DIVISION FOR THE AGENCY, THE WEST VIRGINIA DIVISION OF HIGHWAYS, IS SOLICITING BIDS TO PROVIDE THE AGENCY WITH AN ICAP 6300 DUO VIEW ICP-OES SPECTROMETER OR EQUAL PER THE ATTACHED SPECIFICATIONS.</p>						
***** THIS IS THE END OF RFQ 7713005 ***** TOTAL:						51,973.60

RECEIVED  
 2012 NOV -7 AM 9:02  
 WV PURCHASING DIVISION

\* Agilent Technologies, Inc. (Agilent) is bidding in accordance with quotation 1294938 which is hereby incorporated by reference. Agilent is bidding an equivalent instrument. If Agilent should be a successful bidder, please reference quotation number 1294938 on your purchase order.

SIGNATURE * <i>Jeff H...</i>	TELEPHONE 800-227-9770	DATE 5 Nov. 2012
TITLE Business Sales Specialist	FEIN 77-0518772	ADDRESS CHANGES TO BE NOTED ABOVE

WHEN RESPONDING TO SOLICITATION, INSERT NAME AND ADDRESS IN SPACE ABOVE LABELED 'VENDOR'

INSTRUCTIONS TO VENDORS SUBMITTING BIDS

- 1. **REVIEW DOCUMENTS THOROUGHLY:** The attached documents contain a solicitation for bids. Please read these instructions and all documents attached in their entirety. These instructions provide critical information about requirements that if overlooked could lead to disqualification of a Vendor's bid. All bids must be submitted in accordance with the provisions contained in these instructions and the Solicitation. Failure to do so may result in disqualification of Vendor's bid.
- 2. **MANDATORY TERMS:** The Solicitation may contain mandatory provisions identified by the use of the words "must," "will," and "shall." Failure to comply with a mandatory term in the Solicitation will result in bid disqualification.
- 3. **PREBID MEETING:** The item identified below shall apply to this Solicitation.

| A pre-bid meeting will not be held prior to bid opening.

| A NON-MANDATORY PRE-BID meeting will be held at the following place and time:

| A MANDATORY PRE-BID meeting will be held at the following place and time:

All Vendors submitting a bid must attend the mandatory pre-bid meeting. Failure to attend the mandatory pre-bid meeting shall result in disqualification of the Vendor's bid. No one person attending the pre-bid meeting may represent more than one Vendor.

An attendance sheet provided at the pre-bid meeting shall serve as the official document verifying attendance. The State will not accept any other form of proof or documentation to verify attendance. Any person attending the pre-bid meeting on behalf of a Vendor must list on the attendance sheet his or her name and the name of the Vendor he or she is representing. Additionally, the person attending the pre-bid meeting should include the Vendor's E-Mail address, phone number, and Fax number on the attendance sheet. It is the Vendor's responsibility to locate the attendance sheet and provide the required

information. Failure to complete the attendance sheet as required may result in disqualification of Vendor's bid.

All Vendors should arrive prior to the starting time for the pre-bid. Vendors who arrive after the starting time but prior to the end of the pre-bid will be permitted to sign in, but are charged with knowing all matters discussed at the pre-bid.

Questions submitted at least five business days prior to a scheduled pre-bid will be discussed at the pre-bid meeting if possible. Any discussions or answers to questions at the pre-bid meeting are preliminary in nature and are non-binding. Official and binding answers to questions will be published in a written addendum to the Solicitation prior to bid opening.

4. **VENDOR QUESTION DEADLINE:** Vendors may submit questions relating to this Solicitation to the Purchasing Division. Questions must be submitted in writing. All questions must be submitted on or before the date listed below and to the address listed below in order to be considered. A written response will be published in a Solicitation addendum if a response is possible and appropriate. Non-written discussions, conversations, or questions and answers regarding this Solicitation are preliminary in nature and are non-binding.

Question Submission Deadline: 11/05/2012

Submit Questions to:

Alan Cummings

2019 Washington Street, East

P.O. Box 50130

Charleston, WV 25305

Fax: 304-558-4115

Email: Alan.W.Cummings@WV.Gov

5. **VERBAL COMMUNICATION:** Any verbal communication between the Vendor and any State personnel is not binding, including that made at the mandatory pre-bid conference. Only information issued in writing and added to the Solicitation by an official written addendum by the Purchasing Division is binding.
6. **BID SUBMISSION:** All bids must be signed and delivered by the Vendor to the Purchasing Division at the address listed below on or before the date and time of the bid opening. Any bid received by the Purchasing Division staff is considered to be in the possession of the Purchasing Division and will not be returned for any reason. The bid delivery address is:

Department of Administration, Purchasing Division  
2019 Washington Street East  
P.O. Box 50130,  
Charleston, WV 25305-0130

The bid should contain the information listed below on the face of the envelope or the bid may not be considered:

SEALED BID

BUYER: \_\_\_\_\_  
 SOLICITATION NO.: \_\_\_\_\_  
 BID OPENING DATE: \_\_\_\_\_  
 BID OPENING TIME: \_\_\_\_\_  
 FAX NUMBER: \_\_\_\_\_

In the event that Vendor is responding to a request for proposal, the Vendor shall submit one original technical and one original cost proposal plus  convenience copies of each to the Purchasing Division at the address shown above. Additionally, the Vendor should identify the bid type as either a technical or cost proposal on the face of each bid envelope submitted in response to a request for proposal as follows:

BID TYPE:     | Technical  
                    | Cost

7. **BID OPENING:** Bids submitted in response to this Solicitation will be opened at the location identified below on the date and time listed below. Delivery of a bid after the bid opening date and time will result in bid disqualification. For purposes of this Solicitation, a bid is considered delivered when time stamped by the official Purchasing Division time clock.

**Bid Opening Date and Time:**

11/07/2012 - 1:30 P.M.

**Bid Opening Location:**

Department of Administration, Purchasing Division  
 2019 Washington Street East  
 P.O. Box 50130,  
 Charleston, WV 25305-0130

8. **ADDENDUM ACKNOWLEDGEMENT:** Changes or revisions to this Solicitation will be made by an official written addendum issued by the Purchasing Division. Vendor should acknowledge receipt of all addenda issued with this Solicitation by completing an Addendum Acknowledgment Form, a copy of which is included herewith. Failure to acknowledge addenda may result in bid disqualification. The addendum acknowledgement should be submitted with the bid to expedite document processing.
9. **BID FORMATTING:** Vendor should type or electronically enter the information onto its bid to prevent errors in the evaluation. Failure to type or electronically enter the information may result in bid disqualification.

**GENERAL TERMS AND CONDITIONS:**

1. **CONTRACTUAL AGREEMENT:** Issuance of a Purchase Order signed by the Purchasing Division Director, or his designee, and approved as to form by the Attorney General's office constitutes acceptance of this Contract made by and between the State of West Virginia and the Vendor. Vendor's signature on its bid signifies Vendor's agreement to be bound by and accept the terms and conditions contained in this Contract.
  
2. **DEFINITIONS:** As used in this Solicitation / Contract, the following terms shall have the meanings attributed to them below. Additional definitions may be found in the specifications included with this Solicitation / Contract.
  - 2.1 **"Agency" or "Agencies"** means the agency, board, commission, or other entity of the State of West Virginia that is identified on the first page of the Solicitation or any other public entity seeking to procure goods or services under this Contract.
  
  - 2.2 **"Contract"** means the binding agreement that is entered into between the State and the Vendor to provide the goods and services requested in the Solicitation.
  
  - 2.3 **"Director"** means the Director of the West Virginia Department of Administration, Purchasing Division.
  
  - 2.4 **"Purchasing Division"** means the West Virginia Department of Administration, Purchasing Division.
  
  - 2.5 **"Purchase Order"** means the document signed by the Agency and the Purchasing Division, and approved as to form by the Attorney General, that identifies the Vendor as the successful bidder and Contract holder.
  
  - 2.6 **"Solicitation"** means the official solicitation published by the Purchasing Division and identified by number on the first page thereof.
  
  - 2.7 **"State"** means the State of West Virginia and/or any of its agencies, commissions, boards, etc. as context requires.
  
  - 2.8 **"Vendor" or "Vendors"** means any entity submitting a bid in response to the Solicitation, the entity that has been selected as the lowest responsible bidder, or the entity that has been awarded the Contract as context requires.

3. **CONTRACT TERM; RENEWAL; EXTENSION:** The term of this Contract shall be determined in accordance with the category that has been identified as applicable to this Contract below:

| | **Term Contract**

**Initial Contract Term:** This Contract becomes effective on [ ]  
[ ]  
and extends for a period of [ ] year(s).

**Renewal Term:** This Contract may be renewed upon the mutual written consent of the Agency, and the Vendor, with approval of the Purchasing Division and the Attorney General's office (Attorney General approval is as to form only). Any request for renewal must be submitted to the Purchasing Division Director thirty (30) days prior to the expiration date of the initial contract term or appropriate renewal term. A Contract renewal shall be in accordance with the terms and conditions of the original contract. Renewal of this Contract is limited to [ ] successive one (1) year periods. Automatic renewal of this Contract is prohibited. Notwithstanding the foregoing, Purchasing Division approval is not required on agency delegated or exempt purchases. Attorney General approval may be required for vendor terms and conditions.

**Reasonable Time Extension:** At the sole discretion of the Purchasing Division Director, and with approval from the Attorney General's office (Attorney General approval is as to form only), this Contract may be extended for a reasonable time after the initial Contract term or after any renewal term as may be necessary to obtain a new contract or renew this Contract. Any reasonable time extension shall not exceed twelve (12) months. Vendor may avoid a reasonable time extension by providing the Purchasing Division Director with written notice of Vendor's desire to terminate this Contract 30 days prior to the expiration of the then current term. During any reasonable time extension period, the Vendor may terminate this Contract for any reason upon giving the Purchasing Division Director 30 days written notice. Automatic extension of this Contract is prohibited. Notwithstanding the foregoing, Purchasing Division approval is not required on agency delegated or exempt purchases, but Attorney General approval may be required.

| | **Fixed Period Contract:** This Contract becomes effective upon Vendor's receipt of the notice to proceed and must be completed within [ ] days.

|  | **One Time Purchase:** The term of this Contract shall run for one year from the date the Purchase Order is issued or from the date the Purchase Order is issued until all of the goods contracted for have been delivered, whichever is shorter.

| | **Other:** See attached.

4. **NOTICE TO PROCEED:** Vendor shall begin performance of this Contract immediately upon receiving notice to proceed unless otherwise instructed by the Agency. Unless otherwise specified, the fully executed Purchase Order will be considered notice to proceed
5. **QUANTITIES:** The quantities required under this Contract shall be determined in accordance with the category that has been identified as applicable to this Contract below.
- | | **Open End Contract:** Quantities listed in this Solicitation are approximations only, based on estimates supplied by the Agency. It is understood and agreed that the Contract shall cover the quantities actually ordered for delivery during the term of the Contract, whether more or less than the quantities shown.
  - | | **Service:** The scope of the service to be provided will be more clearly defined in the specifications included herewith.
  - | | **Combined Service and Goods:** The scope of the service and deliverable goods to be provided will be more clearly defined in the specifications included herewith.
  - |  | **One Time Purchase:** This Contract is for the purchase of a set quantity of goods that are identified in the specifications included herewith. Once those items have been delivered, no additional goods may be procured under this Contract without an appropriate change order approved by the Vendor, Agency, Purchasing Division, and Attorney General's office.
6. **PRICING:** The pricing set forth herein is firm for the life of the Contract, unless specified elsewhere within this Solicitation/Contract by the State. A Vendor's inclusion of price adjustment provisions in its bid, without an express authorization from the State in the Solicitation to do so, may result in bid disqualification.
7. **EMERGENCY PURCHASES:** The Purchasing Division Director may authorize the Agency to purchase goods or services in the open market that Vendor would otherwise provide under this Contract if those goods or services are for immediate or expedited delivery in an emergency. Emergencies shall include, but are not limited to, delays in transportation or an unanticipated increase in the volume of work. An emergency purchase in the open market, approved by the Purchasing Division Director, shall not constitute of breach of this Contract and shall not entitle the Vendor to any form of compensation or damages. This provision does not excuse the State from fulfilling its obligations under a One Time Purchase contract.
8. **REQUIRED DOCUMENTS:** All of the items checked below must be provided to the Purchasing Division by the Vendor as specified below.
- | | **BID BOND:** All Vendors shall furnish a bid bond in the amount of five percent (5%) of the total amount of the bid protecting the State of West Virginia. The bid bond must be submitted with the bid.

- | | **PERFORMANCE BOND:** The apparent successful Vendor shall provide a performance bond in the amount of . The performance bond must be issued and received by the Purchasing Division prior to Contract award. On construction contracts, the performance bond must be 100% of the Contract value.
- | | **LABOR/MATERIAL PAYMENT BOND:** The apparent successful Vendor shall provide a labor/material payment bond in the amount of 100% of the Contract value. The labor/material payment bond must be issued and delivered to the Purchasing Division prior to Contract award.

In lieu of the Bid Bond, Performance Bond, and Labor/Material Payment Bond, the Vendor may provide certified checks, cashier's checks, or irrevocable letters of credit. Any certified check, cashier's check, or irrevocable letter of credit provided in lieu of a bond must be of the same amount and delivered on the same schedule as the bond it replaces. A letter of credit submitted in lieu of a performance and labor/material payment bond will only be allowed for projects under \$100,000. Personal or business checks are not acceptable.

- | | **MAINTENANCE BOND:** The apparent successful Vendor shall provide a two (2) year maintenance bond covering the roofing system. The maintenance bond must be issued and delivered to the Purchasing Division prior to Contract award.
- | | **WORKERS' COMPENSATION INSURANCE:** The apparent successful Vendor shall have appropriate workers' compensation insurance and shall provide proof thereof upon request.
- | | **INSURANCE:** The apparent successful Vendor shall furnish proof of the following insurance prior to Contract award:

- | | **Commercial General Liability Insurance:**  
 or more.
- | | **Builders Risk Insurance:** builders risk – all risk insurance in an amount equal to 100% of the amount of the Contract.
- | |
- | |
- | |
- | |
- | |



The apparent successful Vendor shall also furnish proof of any additional insurance requirements contained in the specifications prior to Contract award regardless of whether or not that insurance requirement is listed above.

**LICENSE(S) / CERTIFICATIONS / PERMITS:** In addition to anything required under the Section entitled Licensing, of the General Terms and Conditions, the apparent successful Vendor shall furnish proof of the following licenses, certifications, and/or permits prior to Contract award, in a form acceptable to the Purchasing Division.

[		
[		
[		
[		

The apparent successful Vendor shall also furnish proof of any additional licenses or certifications contained in the specifications prior to Contract award regardless of whether or not that requirement is listed above.

**9. LITIGATION BOND:** The Director reserves the right to require any Vendor that files a protest of an award to submit a litigation bond in the amount equal to one percent of the lowest bid submitted or \$5,000, whichever is greater. The entire amount of the bond shall be forfeited if the hearing officer determines that the protest was filed for frivolous or improper purpose, including but not limited to, the purpose of harassing, causing unnecessary delay, or needless expense for the Agency. All litigation bonds shall be made payable to the Purchasing Division. In lieu of a bond, the protester may submit a cashier's check or certified check payable to the Purchasing Division. Cashier's or certified checks will be deposited with and held by the State Treasurer's office. If it is determined that the protest has not been filed for frivolous or improper purpose, the bond or deposit shall be returned in its entirety.

**10. ALTERNATES:** Any model, brand, or specification listed herein establishes the acceptable level of quality only and is not intended to reflect a preference for, or in any way favor, a particular brand or vendor. Vendors may bid alternates to a listed model or brand provided that the alternate is at least equal to the model or brand and complies with the required specifications. The equality of any alternate being bid shall be determined by the State at its sole discretion. Any Vendor bidding an alternate model or brand should clearly identify the alternate items in its bid and should include manufacturer's specifications, industry literature, and/or any other relevant documentation demonstrating the equality of the alternate items. Failure to provide information for alternate items may be grounds for rejection of a Vendor's bid.

**11. EXCEPTIONS AND CLARIFICATIONS:** The Solicitation contains the specifications that shall form the basis of a contractual agreement. Vendor shall clearly mark any exceptions, clarifications, or

other proposed modifications in its bid. Exceptions to, clarifications of, or modifications of a requirement or term and condition of the Solicitation may result in bid disqualification.

**12. LIQUIDATED DAMAGES:** Vendor shall pay liquidated damages in the amount

	for	

This clause shall in no way be considered exclusive and shall not limit the State or Agency's right to pursue any other available remedy.

**13. ACCEPTANCE/REJECTION:** The State may accept or reject any bid in whole, or in part. Vendor's signature on its bid signifies acceptance of the terms and conditions contained in the Solicitation and Vendor agrees to be bound by the terms of the Contract, as reflected in the Purchase Order, upon receipt.

**14. REGISTRATION:** Prior to Contract award, the apparent successful Vendor must be properly registered with the West Virginia Purchasing Division and must have paid the \$125 fee if applicable.

**15. COMMUNICATION LIMITATIONS:** In accordance with West Virginia Code of State Rules §148-1-6.6, communication with the State of West Virginia or any of its employees regarding this Solicitation during the solicitation, bid, evaluation or award periods, except through the Purchasing Division, is strictly prohibited without prior Purchasing Division approval. Purchasing Division approval for such communication is implied for all agency delegated and exempt purchases.

**16. FUNDING:** This Contract shall continue for the term stated herein, contingent upon funds being appropriated by the Legislature or otherwise being made available. In the event funds are not appropriated or otherwise made available, this Contract becomes void and of no effect beginning on July 1 of the fiscal year for which funding has not been appropriated or otherwise made available.

**17. PAYMENT:** Payment in advance is prohibited under this Contract. Payment may only be made after the delivery and acceptance of goods or services. The Vendor shall submit invoices, in arrears, to the Agency at the address on the face of the purchase order labeled "Invoice To."

**18. UNIT PRICE:** Unit prices shall prevail in cases of a discrepancy in the Vendor's bid.

**19. DELIVERY:** All quotations are considered freight on board destination ("F.O.B. destination") unless alternate shipping terms are clearly identified in the bid. Vendor's listing of shipping terms that contradict the shipping terms expressly required by this Solicitation may result in bid disqualification.

**20. INTEREST:** Interest attributable to late payment will only be permitted if authorized by the West Virginia Code. Presently, there is no provision in the law for interest on late payments.

**21. PREFERENCE:** Vendor Preference may only be granted upon written request and only in accordance with the West Virginia Code § 5A-3-37 and the West Virginia Code of State Rules. A Resident Vendor Certification form has been attached hereto to allow Vendor to apply for the preference. Vendor's

failure to submit the Resident Vendor Certification form with its bid will result in denial of Vendor Preference. Vendor Preference does not apply to construction projects.

- 22. SMALL, WOMEN-OWNED, OR MINORITY-OWNED BUSINESSES:** For any solicitations publicly advertised for bid on or after July 1, 2012, in accordance with West Virginia Code §5A-3-37(a)(7) and W. Va. CSR § 148-22-9, any non-resident vendor certified as a small, women-owned, or minority-owned business under W. Va. CSR § 148-22-9 shall be provided the same preference made available to any resident vendor. Any non-resident small, women-owned, or minority-owned business must identify itself as such in writing, must submit that writing to the Purchasing Division with its bid, and must be properly certified under W. Va. CSR § 148-22-9 prior to submission of its bid to receive the preferences made available to resident vendors. Preference for a non-resident small, women-owned, or minority owned business shall be applied in accordance with W. Va. CSR § 148-22-9.
- 23. TAXES:** The Vendor shall pay any applicable sales, use, personal property or any other taxes arising out of this Contract and the transactions contemplated thereby. The State of West Virginia is exempt from federal and state taxes and will not pay or reimburse such taxes.
- 24. CANCELLATION:** The Purchasing Division Director reserves the right to cancel this Contract immediately upon written notice to the vendor if the materials or workmanship supplied do not conform to the specifications contained in the Contract. The Purchasing Division Director may cancel any purchase or Contract upon 30 days written notice to the Vendor in accordance with West Virginia Code of State Rules § 148-1-7.16.2.
- 25. WAIVER OF MINOR IRREGULARITIES:** The Director reserves the right to waive minor irregularities in bids or specifications in accordance with West Virginia Code of State Rules § 148-1-4.6.
- 26. TIME:** Time is of the essence with regard to all matters of time and performance in this Contract.
- 27. APPLICABLE LAW:** This Contract is governed by and interpreted under West Virginia law without giving effect to its choice of law principles. Any information provided in specification manuals, or any other source, verbal or written, which contradicts or violates the West Virginia Constitution, West Virginia Code or West Virginia Code of State Rules is void and of no effect.
- 28. COMPLIANCE:** Vendor shall comply with all applicable federal, state, and local laws, regulations and ordinances. By submitting a bid, Vendors acknowledge that they have reviewed, understand, and will comply with all applicable law.
- 29. PREVAILING WAGE:** On any contract for the construction of a public improvement, Vendor and any subcontractors utilized by Vendor shall pay a rate or rates of wages which shall not be less than the fair minimum rate or rates of wages (prevailing wage), as established by the West Virginia Division of Labor under West Virginia Code §§ 21-5A-1 et seq. and available at <http://www.sos.wv.gov/administrative-law/wagcrates/Pages/default.aspx>. Vendor shall be responsible for ensuring compliance with prevailing wage requirements and determining when prevailing wage

requirements are applicable. The required contract provisions contained in West Virginia Code of State Rules § 42-7-3 are specifically incorporated herein by reference.

30. **ARBITRATION:** Any references made to arbitration contained in this Contract, Vendor's bid, or in any American Institute of Architects documents pertaining to this Contract are hereby deleted, void, and of no effect.
31. **MODIFICATIONS:** This writing is the parties' final expression of intent. Notwithstanding anything contained in this Contract to the contrary, no modification of this Contract shall be binding without mutual written consent of the Agency, and the Vendor, with approval of the Purchasing Division and the Attorney General's office (Attorney General approval is as to form only). **No Change shall be implemented by the Vendor until such time as the Vendor receives an approved written change order from the Purchasing Division.**
32. **WAIVER:** The failure of either party to insist upon a strict performance of any of the terms or provision of this Contract, or to exercise any option, right, or remedy herein contained, shall not be construed as a waiver or a relinquishment for the future of such term, provision, option, right, or remedy, but the same shall continue in full force and effect. Any waiver must be expressly stated in writing and signed by the waiving party.
33. **SUBSEQUENT FORMS:** The terms and conditions contained in this Contract shall supersede any and all subsequent terms and conditions which may appear on any form documents submitted by Vendor to the Agency or Purchasing Division such as price lists, order forms, invoices, sales agreements, or maintenance agreements, and includes internet websites or other electronic documents. Acceptance or use of Vendor's forms does not constitute acceptance of the terms and conditions contained thereon.
34. **ASSIGNMENT:** Neither this Contract nor any monies due, or to become due hereunder, may be assigned by the Vendor without the express written consent of the Agency, the Purchasing Division, the Attorney General's office (as to form only), and any other government agency or office that may be required to approve such assignments. Notwithstanding the foregoing, Purchasing Division approval may or may not be required on certain agency delegated or exempt purchases.
35. **WARRANTY:** The Vendor expressly warrants that the goods and/or services covered by this Contract will: (a) conform to the specifications, drawings, samples, or other description furnished or specified by the Agency; (b) be merchantable and fit for the purpose intended; and (c) be free from defect in material and workmanship.
36. **STATE EMPLOYEES:** State employees are not permitted to utilize this Contract for personal use and the Vendor is prohibited from permitting or facilitating the same.
37. **BANKRUPTCY:** In the event the Vendor files for bankruptcy protection, the State of West Virginia may deem this Contract null and void, and terminate this Contract without notice.

- 38. HIPAA BUSINESS ASSOCIATE ADDENDUM:** The West Virginia State Government HIPAA Business Associate Addendum (BAA), approved by the Attorney General, is available online at <http://www.state.wv.us/admin/purchase/vrc/hipaa.html> and is hereby made part of the agreement provided that the Agency meets the definition of a Covered entity (45 CFR §160.103) and will be disclosing Protected Health Information (45 CFR §160.103) to the Vendor.
- 39. CONFIDENTIALITY:** The Vendor agrees that it will not disclose to anyone, directly or indirectly, any such personally identifiable information or other confidential information gained from the Agency, unless the individual who is the subject of the information consents to the disclosure in writing or the disclosure is made pursuant to the Agency's policies, procedures, and rules. Vendor further agrees to comply with the Confidentiality Policies and Information Security Accountability Requirements, set forth in <http://www.state.wv.us/admin/purchase/privacy/default.html>.
- 40. DISCLOSURE:** Vendor's response to the Solicitation and the resulting Contract are considered public documents and will be disclosed to the public in accordance with the laws, rules, and policies governing the West Virginia Purchasing Division. Those laws include, but are not limited to, the Freedom of Information Act found in West Virginia Code § 29B-1-1 et seq.
- If a Vendor considers any part of its bid to be exempt from public disclosure, Vendor must so indicate by specifically identifying the exempt information, identifying the exemption that applies, providing a detailed justification for the exemption, segregating the exempt information from the general bid information, and submitting the exempt information as part of its bid but in a segregated and clearly identifiable format. Failure to comply with the foregoing requirements will result in public disclosure of the Vendor's bid without further notice. A Vendor's act of marking all or nearly all of its bid as exempt is not sufficient to avoid disclosure and WILL NOT BE HONORED. Vendor's act of marking a bid or any part thereof as "confidential" or "proprietary" is not sufficient to avoid disclosure and WILL NOT BE HONORED. In addition, a legend or other statement indicating that all or substantially all of the bid is exempt from disclosure is not sufficient to avoid disclosure and WILL NOT BE HONORED. Vendor will be required to defend any claimed exemption for nondisclosure in the event of an administrative or judicial challenge to the State's nondisclosure. Vendor must indemnify the State for any costs incurred related to any exemptions claimed by Vendor. Any questions regarding the applicability of the various public records laws should be addressed to your own legal counsel prior to bid submission.
- 41. LICENSING:** In accordance with West Virginia Code of State Rules §148-1-6.1.7, Vendor must be licensed and in good standing in accordance with any and all state and local laws and requirements by any state or local agency of West Virginia, including, but not limited to, the West Virginia Secretary of State's Office, the West Virginia Tax Department, West Virginia Insurance Commission, or any other state agency or political subdivision. Upon request, the Vendor must provide all necessary releases to obtain information to enable the Purchasing Division Director or the Agency to verify that the Vendor is licensed and in good standing with the above entities.

**42. ANTITRUST:** In submitting a bid to, signing a contract with, or accepting a Purchase Order from any agency of the State of West Virginia, the Vendor agrees to convey, sell, assign, or transfer to the State of West Virginia all rights, title, and interest in and to all causes of action it may now or hereafter acquire under the antitrust laws of the United States and the State of West Virginia for price fixing and/or unreasonable restraints of trade relating to the particular commodities or services purchased or acquired by the State of West Virginia. Such assignment shall be made and become effective at the time the purchasing agency tenders the initial payment to Vendor.

**43. VENDOR CERTIFICATIONS:** By signing its bid or entering into this Contract, Vendor certifies (1) that its bid was made without prior understanding, agreement, or connection with any corporation, firm, limited liability company, partnership, person or entity submitting a bid for the same material, supplies, equipment or services; (2) that its bid is in all respects fair and without collusion or fraud; (3) that this Contract is accepted or entered into without any prior understanding, agreement, or connection to any other entity that could be considered a violation of law; and (4) that it has reviewed this RFQ in its entirety; understands the requirements, terms and conditions, and other information contained herein. Vendor's signature on its bid also affirms that neither it nor its representatives have any interest, nor shall acquire any interest, direct or indirect, which would compromise the performance of its services hereunder. Any such interests shall be promptly presented in detail to the Agency.

The individual signing this bid on behalf of Vendor certifies that he or she is authorized by the Vendor to execute this bid or any documents related thereto on Vendor's behalf; that he or she is authorized to bind the Vendor in a contractual relationship; and that, to the best of his or her knowledge, the Vendor has properly registered with any State agency that may require registration.

**44. PURCHASING CARD ACCEPTANCE:** The State of West Virginia currently utilizes a Purchasing Card program, administered under contract by a banking institution, to process payment for goods and services. The Vendor must accept the State of West Virginia's Purchasing Card for payment of all orders under this Contract unless the box below is checked.

Vendor is not required to accept the State of West Virginia's Purchasing Card as payment for all goods and services.

**45. VENDOR RELATIONSHIP:** The relationship of the Vendor to the State shall be that of an independent contractor and no principal-agent relationship or employer-employee relationship is contemplated or created by this Contract. The Vendor as an independent contractor is solely liable for the acts and omissions of its employees and agents. Vendor shall be responsible for selecting, supervising, and compensating any and all individuals employed pursuant to the terms of this Solicitation and resulting contract. Neither the Vendor, nor any employees or subcontractors of the Vendor, shall be deemed to be employees of the State for any purpose whatsoever. Vendor shall be exclusively responsible for payment of employees and contractors for all wages and salaries, taxes, withholding payments, penalties, fees, fringe benefits, professional liability insurance premiums, contributions to insurance and pension, or other deferred compensation plans, including but not limited to, Workers' Compensation and Social Security obligations, licensing fees, *etc.* and the filing of all necessary documents, forms and returns pertinent to all of the foregoing. Vendor shall hold harmless the

State, and shall provide the State and Agency with a defense against any and all claims including, but not limited to, the foregoing payments, withholdings, contributions, taxes, Social Security taxes, and employer income tax returns.

- 46. INDEMNIFICATION:** The Vendor agrees to indemnify, defend, and hold harmless the State and the Agency, their officers, and employees from and against: (1) Any claims or losses for services rendered by any subcontractor, person, or firm performing or supplying services, materials, or supplies in connection with the performance of the Contract; (2) Any claims or losses resulting to any person or entity injured or damaged by the Vendor, its officers, employees, or subcontractors by the publication, translation, reproduction, delivery, performance, use, or disposition of any data used under the Contract in a manner not authorized by the Contract, or by Federal or State statutes or regulations; and (3) Any failure of the Vendor, its officers, employees, or subcontractors to observe State and Federal laws including, but not limited to, labor and wage and hour laws.
- 47. PURCHASING AFFIDAVIT:** In accordance with West Virginia Code § 5A-3-10a, all Vendors are required to sign, notarize, and submit the Purchasing Affidavit stating that neither the Vendor nor a related party owe a debt to the State in excess of \$1,000. The affidavit must be submitted prior to award, but should be submitted with the Vendor's bid. A copy of the Purchasing Affidavit is included herewith.
- 48. ADDITIONAL AGENCY AND LOCAL GOVERNMENT USE:** This Contract may be utilized by and extends to other agencies, spending units, and political subdivisions of the State of West Virginia; county, municipal, and other local government bodies; and school districts ("Other Government Entities"). This Contract shall be extended to the aforementioned Other Government Entities on the same prices, terms, and conditions as those offered and agreed to in this Contract. If the Vendor does not wish to extend the prices, terms, and conditions of its bid and subsequent contract to the Other Government Entities, the Vendor must clearly indicate such refusal in its bid. A refusal to extend this Contract to the Other Government Entities shall not impact or influence the award of this Contract in any manner.
- 49. CONFLICT OF INTEREST:** Vendor, its officers or members or employees, shall not presently have or acquire any interest, direct or indirect, which would conflict with or compromise the performance of its obligations hereunder. Vendor shall periodically inquire of its officers, members and employees to ensure that a conflict of interest does not arise. Any conflict of interest discovered shall be promptly presented in detail to the Agency.
- 50. REPORTS:** Vendor shall provide the Agency and/or the Purchasing Division with the following reports identified by a checked box below:
- [ ] Such reports as the Agency and/or the Purchasing Division may request. Requested reports may include, but are not limited to, quantities purchased, agencies utilizing the contract, total contract expenditures by agency, etc.

- | | Quarterly reports detailing the total quantity of purchases in units and dollars, along with a listing of purchases by agency. Quarterly reports should be delivered to the Purchasing Division via email at [purchasing.requisitions@wv.gov](mailto:purchasing.requisitions@wv.gov).

**51. BACKGROUND CHECK:** In accordance with W. Va. Code § 15-2D-3, the Director of the Division of Protective Services shall require any service provider whose employees are regularly employed on the grounds or in the buildings of the Capitol complex or who have access to sensitive or critical information to submit to a fingerprint-based state and federal background inquiry through the state repository. The service provider is responsible for any costs associated with the fingerprint-based state and federal background inquiry.

After the contract for such services has been approved, but before any such employees are permitted to be on the grounds or in the buildings of the Capitol complex or have access to sensitive or critical information, the service provider shall submit a list of all persons who will be physically present and working at the Capitol complex to the Director of the Division of Protective Services for purposes of verifying compliance with this provision.

The State reserves the right to prohibit a service provider's employees from accessing sensitive or critical information or to be present at the Capitol complex based upon results addressed from a criminal background check.

Service providers should contact the West Virginia Division of Protective Services by phone at (304) 558-9911 for more information.

**52. PREFERENCE FOR USE OF DOMESTIC STEEL PRODUCTS:** Except when authorized by the Director of the Purchasing Division pursuant to W. Va. Code § 5A-3-56, no contractor may use or supply steel products for a State Contract Project other than those steel products made in the United States. A contractor who uses steel products in violation of this section may be subject to civil penalties pursuant to W. Va. Code § 5A-3-56. As used in this section:

- a. "State Contract Project" means any erection or construction of, or any addition to, alteration of or other improvement to any building or structure, including, but not limited to, roads or highways, or the installation of any heating or cooling or ventilating plants or other equipment, or the supply of and materials for such projects, pursuant to a contract with the State of West Virginia for which bids were solicited on or after June 6, 2001.
- b. "Steel Products" means products rolled, formed, shaped, drawn, extruded, forged, cast, fabricated or otherwise similarly processed, or processed by a combination of two or more or such operations, from steel made by the open hearth, basic oxygen, electric furnace, Bessemer or other steel making process.

The Purchasing Division Director may, in writing, authorize the use of foreign steel products if:

- a. The cost for each contract item used does not exceed one tenth of one percent (.1%) of the total



contract cost or two thousand five hundred dollars (\$2,500.00), whichever is greater. For the purposes of this section, the cost is the value of the steel product as delivered to the project; or

- b. The Director of the Purchasing Division determines that specified steel materials are not produced in the United States in sufficient quantity or otherwise are not reasonably available to meet contract requirements.

**53. PREFERENCE FOR USE OF DOMESTIC ALUMINUM, GLASS, AND STEEL:** In Accordance with W. Va. Code § 5-19-1 et seq., and W. Va. CSR § 148-10-1 et seq., for every contract or subcontract, subject to the limitations contained herein, for the construction, reconstruction, alteration, repair, improvement or maintenance of public works or for the purchase of any item of machinery or equipment to be used at sites of public works, only domestic aluminum, glass or steel products shall be supplied unless the spending officer determines, in writing, after the receipt of offers or bids, (1) that the cost of domestic aluminum, glass or steel products is unreasonable or inconsistent with the public interest of the State of West Virginia, (2) that domestic aluminum, glass or steel products are not produced in sufficient quantities to meet the contract requirements, or (3) the available domestic aluminum, glass, or steel do not meet the contract specifications. This provision only applies to public works contracts awarded in an amount more than fifty thousand dollars (\$50,000) or public works contracts that require more than ten thousand pounds of steel products.

The cost of domestic aluminum, glass, or steel products may be unreasonable if the cost is more than twenty percent (20%) of the bid or offered price for foreign made aluminum, glass, or steel products. If the domestic aluminum, glass or steel products to be supplied or produced in a "substantial labor surplus area", as defined by the United States Department of Labor, the cost of domestic aluminum, glass, or steel products may be unreasonable if the cost is more than thirty percent (30%) of the bid or offered price for foreign made aluminum, glass, or steel products.

This preference shall be applied to an item of machinery or equipment, as indicated above, when the item is a single unit of equipment or machinery manufactured primarily of aluminum, glass or steel, is part of a public works contract and has the sole purpose or of being a permanent part of a single public works project. This provision does not apply to equipment or machinery purchased by a spending unit for use by that spending unit and not as part of a single public works project.

All bids and offers including domestic aluminum, glass or steel products that exceed bid or offer prices including foreign aluminum, glass or steel products after application of the preferences provided in this provision may be reduced to a price equal to or lower than the lowest bid or offer price for foreign aluminum, glass or steel products plus the applicable preference. If the reduced bid or offer prices are made in writing and supersede the prior bid or offer prices, all bids or offers, including the reduced bid or offer prices, will be reevaluated in accordance with this rule.

**CERTIFICATION AND SIGNATURE PAGE**

By signing below, I certify that I have reviewed this Solicitation in its entirety; understand the requirements, terms and conditions, and other information contained herein; that I am submitting this bid or proposal for review and consideration; that I am authorized by the bidder to execute this bid or any documents related thereto on bidder's behalf; that I am authorized to bind the bidder in a contractual relationship; and that to the best of my knowledge, the bidder has properly registered with any State agency that may require registration.

Agilent Technologies, Inc.

(Company)

\*

(Authorized Signature)

Jeff Harrigan, Business Sales Specialist

(Representative Name, Title)

800-227-9770

(Phone Number)

302-993-5941

(Fax Number)

November 5, 2012

(Date)

\* Agilent Technologies, Inc. (Agilent) is bidding in accordance with quotation 1294938 which is hereby incorporated by reference. Agilent is bidding an equivalent instrument. If Agilent should be a successful bidder, please reference quotation number 1294938 on your purchase order.

**ADDENDUM ACKNOWLEDGEMENT FORM**

**SOLICITATION NO.:** 7713005

**Instructions:** Please acknowledge receipt of all addenda issued with this solicitation by completing this addendum acknowledgment form. Check the box next to each addendum received and sign below. Failure to acknowledge addenda may result in bid disqualification.

**Acknowledgment:** I hereby acknowledge receipt of the following addenda and have made the necessary revisions to my proposal, plans and/or specification, etc.

**Addendum Numbers Received:**

(Check the box next to each addendum received)

- |   |  |
|---|--|
| <input type="checkbox"/> Addendum No. 1 | <input type="checkbox"/> Addendum No. 6  |
| <input type="checkbox"/> Addendum No. 2 | <input type="checkbox"/> Addendum No. 7  |
| <input type="checkbox"/> Addendum No. 3 | <input type="checkbox"/> Addendum No. 8  |
| <input type="checkbox"/> Addendum No. 4 | <input type="checkbox"/> Addendum No. 9  |
| <input type="checkbox"/> Addendum No. 5 | <input type="checkbox"/> Addendum No. 10 |

I understand that failure to confirm the receipt of addenda may be cause for rejection of this bid. I further understand that any verbal representation made or assumed to be made during any oral discussion held between Vendor's representatives and any state personnel is not binding. Only the information issued in writing and added to the specifications by an official addendum is binding.

\_\_\_\_\_  
Company

\_\_\_\_\_  
Authorized Signature

\_\_\_\_\_  
Date

NOTE: This addendum acknowledgement should be submitted with the bid to expedite document processing.

---

**SPECIFICATIONS**

1. **PURPOSE AND SCOPE:** The West Virginia Purchasing Division is soliciting bids on behalf of WVDOH, MCS&T Division to establish a contract for the one time purchase of an iCAP 6300 Duo View ICP Spectrometer, or equivalent.
2. **DEFINITIONS:** The terms listed below shall have the meanings assigned to them below. Additional definitions can be found in section 2 of the General Terms and Conditions.
  - 2.1 **“Desired Item”** means a compact bench mounted spectrometer, providing simultaneously inductively coupled plasma (ICP) spectrometer, capable of analysis and quantification of trace elements in both liquid and solid samples.
  - 2.2 **“Bid Evaluation Page”** means the page upon which Vendor should list its proposed price for the Desired Items in the manner requested by thereon. The Desired Item is either included on the last page of this RFQ or attached hereto as Exhibit A.
  - 2.3 **“RFQ”** means the official RFQ published by the Purchasing Division and identified as 7713005.
3. **GENERAL REQUIREMENTS:**
  - 3.1 **Mandatory Desired Item Requirements:** Desired Item must meet or exceed the mandatory requirements listed below.
    - 3.1.1 **iCap 6300 Duo View ICP-OES Spectrometer, or equivalent**
      - 3.1.1.1 The Spectrometer must be capable of conducting chemical analysis on samples of plain carbon and low alloy steel, as noted in ASTM E350 Standard, as well as analyzing samples of cements, as noted in ASTM C114, fly ash, as noted in ASTM C311, and road salt, as noted in ASTM D632.
      - 3.1.1.2 The Spectrometer must be capable of simultaneously analyzing required elements with detection limits of less than 1 ppb, and must include duo plasma viewing system providing both axial and radial torch views from a single configuration.

REQUEST FOR QUOTATION  
7713005 Spectrometer

---

- 3.1.1.3 The Spectrometer must be a compact bench mounted unit with dimensions no greater than 840mm (w) x 750mm (d) x 590mm (h), and the system must be supplied complete with the software that allows analyst to add wavelengths, create methods, analyze samples and post-process the data while the spectrometer is acquiring data, and be compatible with Windows XP and Windows 7 operating systems.
- 3.1.1.4 The Spectrometer must be suitable for 200 – 240v: 50/26Hz operation from a single phase 32A/20A supply.
- 3.1.1.5 The Spectrometer must employ a water cooled RF generator with safety interlocks throughout the system providing safe shut down of the generator without damage to the instrument in the event of power failure. In addition, all failure events must be recorded to an electronic journal.
- 3.1.1.6 The Spectrometer must employ a triple stage cooled Charge Injection Device (CID) detector, cooled to -45°C with solid state electronics to ensure high contrast/low noise imaging and quantification of all wavelengths in the analytical range without blooming. The CID must be photoactive over the whole surface area to enable continuous wavelength coverage and must contain a minimum of 540 x 540 pixels.

#### 4. CONTRACT AWARD:

- 4.1 Contract Award:** The Contract is intended to provide Agencies with a purchase price for the Desired Items. The Contract shall be awarded to the Vendor that provides the Desired Items meeting the required specifications for the lowest overall total cost as shown on the Pricing Pages.
- 4.2 Bid Evaluation Page:** Vendor should complete the Bid Evaluation Page in full as failure to complete the Bid Evaluation Page in its entirety may result in Vendor's bid being disqualified.

Notwithstanding the foregoing, the Purchasing Division may correct errors as it deems appropriate. Vendor should type or electronically enter the information into the Bid Evaluation Page to prevent errors in the evaluation.

**5. PAYMENT:**

**5.1 Payment:** Vendor shall accept payment in accordance with the payment procedures of the State of West Virginia. Methods of acceptable payment must include the West Virginia Purchasing Card. Payment in advance is not permitted under this Contract.

**6. DELIVERY AND RETURN:**

**6.1 Shipment and Delivery:** Vendor shall ship the Desired Items immediately after being awarded this Contract and receiving a purchase order or notice to proceed. Vendor shall deliver the Desired Items within 6-8 weeks ARO after receiving a purchase order or notice to proceed. Desired Items must be delivered to Agency at 190 Dry Branch Drive, Charleston, WV 25306.

**6.2 Late Delivery:** The Agency placing the order under this Contract must be notified in writing if the shipment of the Desired Items will be delayed for any reason. Any delay in delivery that could cause harm to an Agency will be grounds for cancellation of the Contract, and/or obtaining the Desired Items from a third party.

Any Agency seeking to obtain the Desired Items from a third party under this provision must first obtain approval of the Purchasing Division.

**6.3 Delivery Payment/Risk of Loss:** Vendor shall deliver the Desired Items F.O.B. destination to the Agency's location.

**6.4 Return of Unacceptable Items:** If the Agency deems the Desired Items to be unacceptable, the Desired Items shall be returned to Vendor at Vendor's expense and with no restocking charge. Vendor shall either make arrangements for the return within five (5) days of being notified that items are unacceptable, or permit the Agency to arrange for the return and reimburse Agency for delivery expenses. If the original packaging cannot be utilized for the return, Vendor will supply the Agency with appropriate return packaging upon request. All returns of unacceptable items shall be F.O.B. the Agency's location. The returned product shall either be replaced, or the Agency shall receive a full credit or refund for the purchase price, at the Agency's discretion.

REQUEST FOR QUOTATION  
7713005 Spectrometer

---

- 6.5 Return Due to Agency Error:** Items ordered in error by the Agency will be returned for credit within 30 days of receipt, F.O.B. Vendor's location. Vendor shall not charge a restocking fee if returned products are in a resalable condition. Items shall be deemed to be in a resalable condition if they are unused and in the original packaging. Any restocking fee for items not in a resalable condition shall be the lower of the Vendor's customary restocking fee or 5% of the total invoiced value of the returned items.

Exhibit A

**Cost Sheet**  
**RFQ#: 7713005**

<b>Item Number</b>	<b>Quantity</b>	<b>Unit of Measure</b>	<b>Description</b>	<b>"Or Equal" Part Number / Description</b>	<b>Unit Price</b>
1	1	ea	DUO VIEW ICP-OES Icap 6300	G8464AA: Agilent 710 ICP-OES	51,973.60



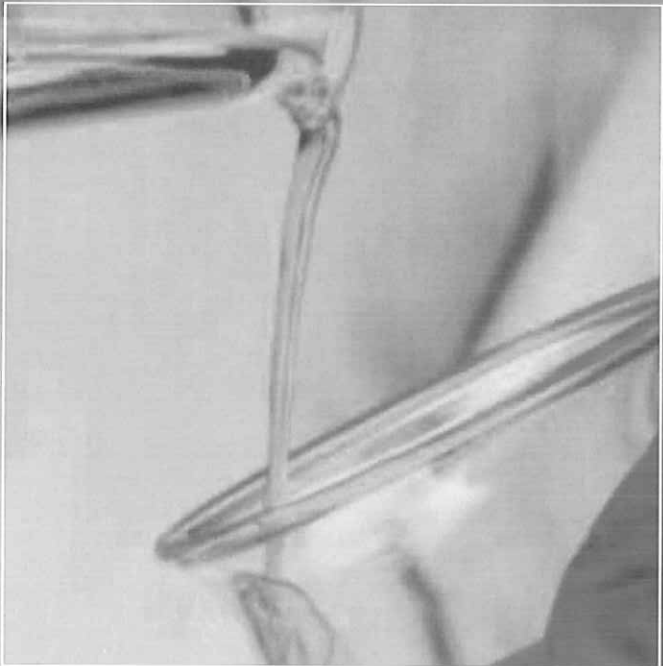

**Accurate. Robust. Reliable.**

AGILENT 710 SERIES ICP-OES

The Measure of Confidence



**Agilent Technologies**



# accurate

## AGILENT 710 SERIES ICP-OES

Agilent Technologies is now your premier resource and partner for atomic spectroscopy. With the 2010 addition of Varian's world-renowned AA and ICP-OES products, together with our market-leading 7700 Series ICP-MS, Agilent offers you a comprehensive range of inorganic analytical instrumentation.

### Outstanding value

The Agilent 710 Series ICP-OES offers uncompromised performance for laboratories with low to moderate sample loads performing routine ICP-OES analyses. Easy to use, the 710 Series is also ideal for educational institutes and industries that need to comply with WEEE/RoHS directives.

- Continuous wavelength coverage provides extended dynamic range and reduced interferences, giving you maximum confidence in your results
- Robust plasma ensures reliable and reproducible results — even with the most complex matrices
- One view, one step measurement of major, minor, and trace elements, plus the fastest warm-up increases throughput and productivity
- Choice of optimized axial (710) or radial (715) configurations to suit your application needs
- Intuitive, powerful, and easy-to-use software

Agilent is committed to continued product development across our entire range of atomic spectroscopy product lines. We are dedicated to delivering to you innovative technology, best-in-class quality and reliability, and unmatched support.

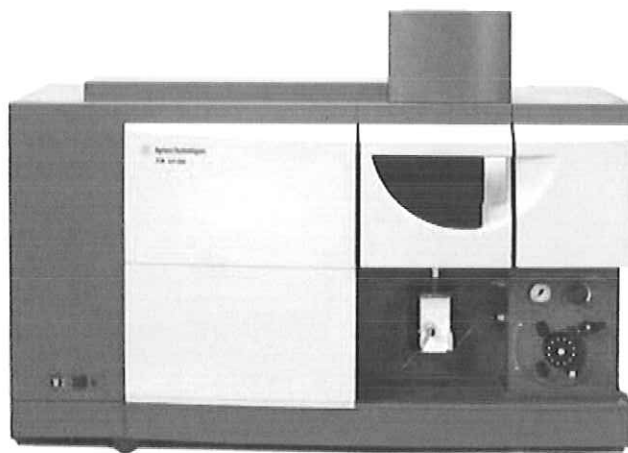

*The Agilent 710 Series ICP-OES features a solid state CCD detector, ideal for laboratories with moderate sample loads that value uncompromised performance.*

## Agilent

<b>1938</b> HP is formed	<b>1965</b> HP enters the gas chromatography market	<b>1976</b> HP 5992A introduced as the world's first benchtop GC/MS	<b>1983</b> HP redefines 'reliability' in GC with the introduction of the HP 5890A	<b>1994</b> Launch of the 4500 Series, the world's first benchtop ICP-MS	<b>2009</b> Launch of the Agilent 7700 Series ICP-MS featuring Agilent's HMI & ORS <sup>3</sup> Cell	<b>2010</b> Varian becomes a part of Agilent
-----------------------------	--	--	---	---	---	---

## Varian

<b>1948</b> Varian Associates is formed	<b>1957</b> Built components for world's first AA (as Techtron)	<b>1991</b> Releases first sequential ICP-OES	<b>1994</b> Axial ICP-OES with cooled cone interface released	<b>1997</b> Patented Vista chip CCD detector with full wavelength coverage	<b>2006</b> Launch of the 700 Series ICP-OES — world's fastest ICP-OES
--	--	--	--	---	---

### Stable and accurate results for all sample types

With over 6,000 ICP-OES systems worldwide, Agilent's plasma generation is field-proven, robust, and consistently provides stable and accurate results, even with the most challenging samples.

- Superior plasma performance allows direct analysis of samples ranging from organic solvents to industrial waste and brines, minimizing sample preparation times.
- Agilent's innovative cooled cone interface eliminates the use of expensive shear gases, saving you money.
- Advanced optical design with no moving parts and robust plasma generation ensure superb long term stability.
- The CCD detector and optimized optical design give excellent signal-to-noise performance, ensuring low detection limits.
- The dedicated sample introduction system and axially-viewed plasma of the 710 Series ICP-OES provide maximum sensitivity for routine trace-level applications.
- The radially-viewed 715 ICP-OES features efficient sample introduction for maximum robustness, allowing you to analyze the most demanding samples with ease.
- Enhance the performance of the 710 Series with accessories such as the VGA for mercury and hydride forming elements, the fast SPS autosampler for unattended automation, the SVS switching valve for immediate rinsing and improved productivity, the AGM for organic matrices and the USN for lower detection limits with environmental samples.

### Industry leading performance

Achieve accurate and precise results for low wavelength elements at  $\mu\text{g/L}$  levels. Results are shown for toxic elements in polyethylene (European Reference Material EC681) measured on the 710 Series (corrected for 100-fold dilution).

	Certified range mg/kg	Measured value mg/kg
Hg 184.887	4.35 – 4.65	4.60
Cd 214.439	21.0 – 22.4	21.7
Pb 220.353	13.1 – 14.5	13.7
Cr 267.716	17.1 – 18.3	17.5

### Fastest warm-up time

Shown is the rapid stabilization of Ar, Ba, Mg, and Zn following plasma ignition. Exceptionally fast warm-up time allows samples to be analyzed in less than 10 minutes after plasma ignition, minimizing delays and saving argon costs.

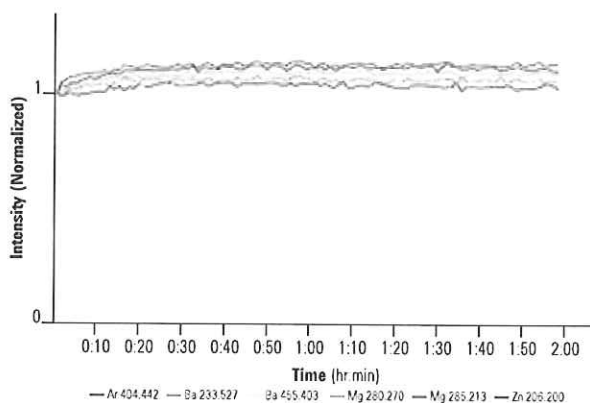

# robust



## ONE-STEP ANALYSIS FROM ONE PLASMA VIEW

### Productivity and dynamic range for environmental applications

The determination of major, trace and toxic elements in soils, waters, food and agricultural samples is fast and easy using a single plasma view. Agilent's 710 horizontal, axially-viewed plasma provides excellent sensitivity for trace-level determinations, and the flexibility to handle major levels. The robust plasma is able to handle a wide variety of sample matrices while still delivering the best detection limits. Agilent's unique Multi-Cal feature extends the linear range of analysis from parts-per-billion to percentage levels. Unlike dual view systems, the Agilent 710 Series provides extended range without having to analyze the sample twice.

This extended linear dynamic range, coupled with the freedom from interferences offered by the CCD detector, makes the 710 ICP-OES ideal for environmental applications. When combined with microwave digestion the 710 can also be used for routine monitoring of heavy metals in plastic for compliance with RoHS and WEEE regulations.

The 710 axial system meets all US EPA Contract Required Detection Limits (CRDL) for waters and waste waters and is capable of routinely handling up to 5% dissolved salts. The stability, wide linear dynamic range and reduced chemical interferences of the 710 ICP-OES ensure that your laboratory can analyze more samples every day.

*Fast, accurate analysis of environmental samples*  
Measurement of 22 target analytes required for compliance with USEPA ILM05.3 takes only 3 min 34 sec per sample.

Element	NIST 1643e certified (mg/L)	NIST 1643e measured LCS (mg/L)	CRDL (mg/L)	LCS % recovery
Ag 328.068	0.001062	<CRQL	10	—
Al 308.215	0.1418	0.153	200	108%
As 188.980	0.06045	0.0571	10	95%
Ba 585.367	0.5442	0.558	200	103%
Be 234.861	0.01398	0.0136	5	97%
Ca 370.602	32.3	32.3	5000	100%
Cd 226.502	0.006568	0.00650	5000	99%
Co 228.615	0.02706	0.0284	5	105%
Cr 267.716	0.0204	0.0209	50	103%
Cu 324.754	0.02276	0.0217	25	95%
Fe 258.588	0.0981	0.104	100	106%
K 769.897	2.034	2.13	5000	105%
Mg 279.800	8.037	7.85	5000	98%
Mn 257.610	0.03897	0.0409	15	105%
Na 589.592	20.74	21.0	5000	101%
Ni 231.604	0.06241	0.0632	40	101%
Pb 220.353	0.01963	0.0192	10	98%
Sb 206.834	0.0583	0.0591	60	101%
Se 196.026	0.01197	<CRQL	35	—
Tl 190.794	0.007445	<CRQL	25	—
V 311.837	0.03786	0.0361	50	95%
Zn 206.200	0.0785	0.0802	60	102%

### Minimize interferences

The Cooled Cone Interface (CCI) efficiently removes the cool plasma tail (the red zone, top) away from the optical path. This minimizes self-absorption and recombination interferences to provide a wide linear dynamic range and low background for the best detection limits. Dual view plasmas (bottom), do not fully remove the cool plasma tail, degrading performance and linear dynamic range.

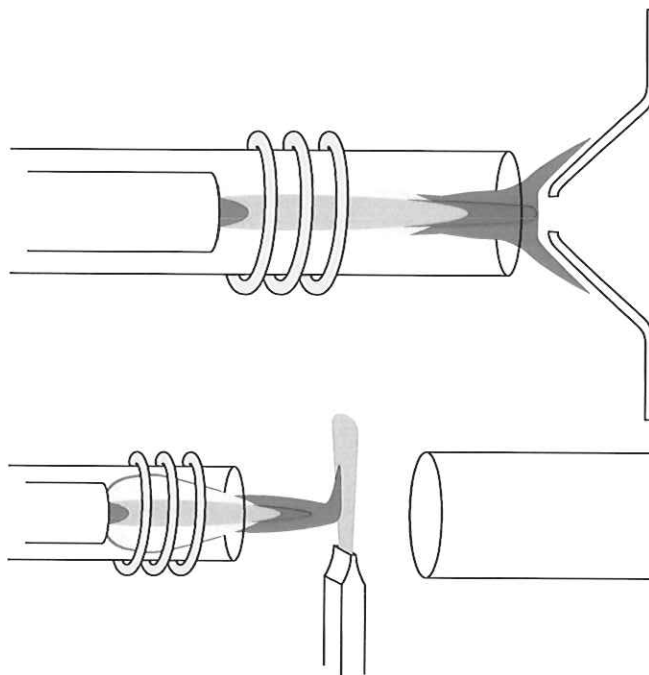

### Robust performance for industrial applications

If long term analysis of the most difficult sample types is required, Agilent's 715 ICP-OES offers the benefits of robust operation with minimal maintenance. The radially-viewed plasma is vertically oriented, providing immediate venting of exhaust vapors for reduced injector tube blockage and long term stable performance with high levels of dissolved solids. Vertically orientated, radially-viewed plasma systems are the accepted standard in many industries including chemicals manufacture, salt production, wear metals analysis, petrochemical production and precious metals refining. Dual view plasma systems, which feature horizontal torches, cannot match the rugged, high dissolved salt performance of the 715 ICP-OES.

Agilent's robust RF generator system provides the rugged stability needed to ensure excellent long term stability with challenging samples. The radial configuration is also preferred for organic applications as the vertical plasma reduces carbon build up in the injector. Use the programmable viewing height to select the optimum viewing position in the plasma, reduce background, and eliminate interferences from carbon and oxygen based molecular emissions. This means improved detection limits are achieved without the use of oxygen.

Whether you are performing process control in the petrochemical industry, determining major, minor and trace compositions of rocks, soils or sediments, or measuring contaminants in used oils, the 715 ICP-OES offers stable, reliable performance for all sample types.

### Stable and reliable performance

Four hour stability study for 5 mg/L S21 elements in directly aspirated kerosene shows the stable and reliable performance of the 715 ICP-OES for difficult organic solvents.

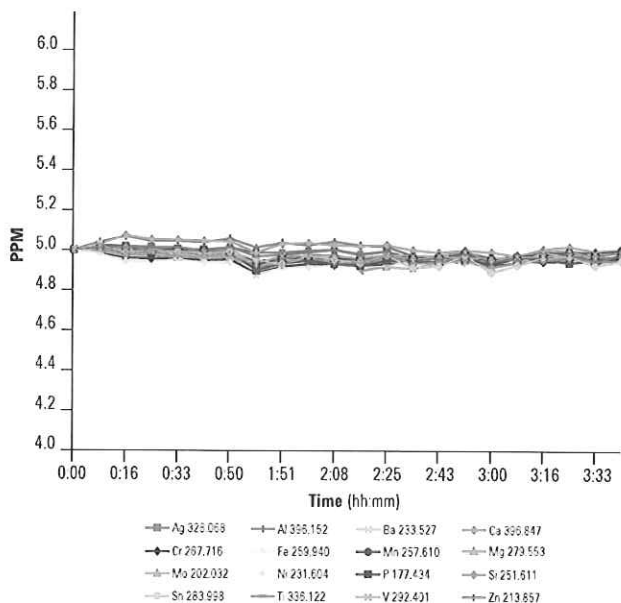

# reliable

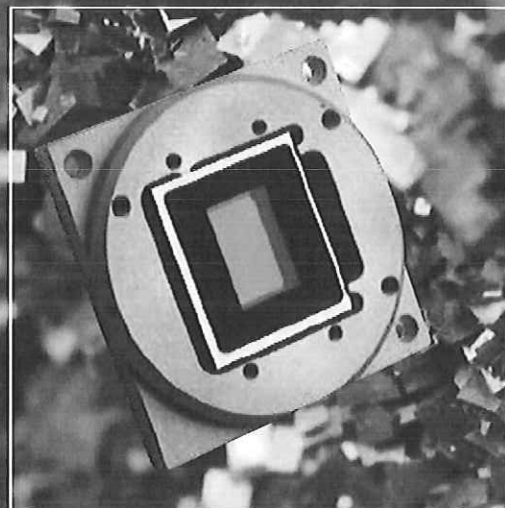

## CLEARLY BETTER SOFTWARE

User friendly software with all instrument controls, sample results and signal graphics accessible from one window.

### Software designed for real samples

- Easy-to-use worksheet-based software contains wizards and videos to guide you through operation.
- Fitted background correction simplifies method development as you don't need to select correction points manually. This ensures fast method development and better correction.
- Agilent's Fast Automated Curve-fitting Technique (FACT) resolves complex spectral interferences, ensuring greater accuracy in difficult matrices. FACT modeling can be applied post-analysis.
- MultiCal extends the linear range giving you accurate results from a single measurement.
- The status display provides an overview of instrument settings and includes diagnostics for performance optimization and fast fault diagnosis.

### Confirm your results automatically

Prove you have accurate results for unknown samples. With MultiCal you can monitor results at two or more wavelengths for each element — giving you confidence in your results and confirming they are interference free.

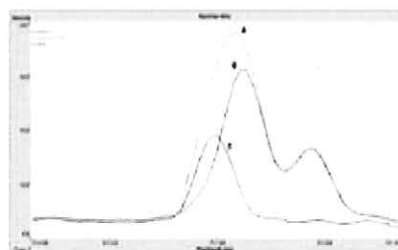

**Resolve spectral interference with FACT**  
Resolution of the difficult Fe interference at Cd 214.438 nm. Shown are:  
a. Appearance of the peaks in a soil sample  
b. FACT model of the interference (500 mg/L Fe)  
c. Corrected signal for the Cd analyte.

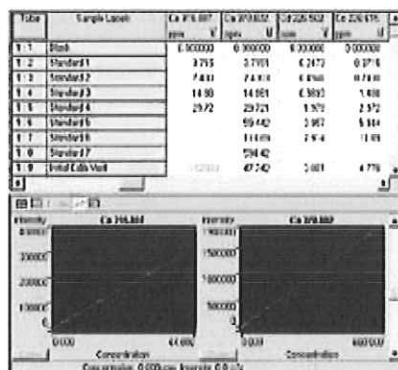

**Extend linear range**  
With MultiCal, results are automatically assigned either to the Ca 315.887 nm wavelength calibrated to 30 mg/L or the 370.602 nm wavelength calibrated to 600 mg/L. The Initial Calibration Verification standard is accurately recovered at 47.7 mg/L (%R = 106%).

# SIMULTANEOUS ICP-OES

Whether you have tens or hundreds of samples to analyze each day, the Agilent 710 Series ICP-OES will save you time and money.

The detector provides over 1.1 million pixels in a large area, CCD array design. It captures the entire spectral image in one reading, saving you time and reducing running costs. Simultaneous ICP measurement means simultaneous background correction and internal standardization — resulting in more accurate and precise

results with excellent long term stability. The unique CCD array detector is cooled to  $-30\text{ }^{\circ}\text{C}$  for excellent low noise performance and best possible detection limits. For the best value simultaneous ICP-OES, choose the Agilent 710 Series.

*The productivity of simultaneous ICP-OES — all wavelengths are captured in one reading without time consuming scanning.*

*To ensure data integrity and a wide dynamic range the CCD features the Clocked Recombination System (CRS) for anti-blooming protection.*

*Spectral interferences are easily avoided. Choose any line from 175–785 nm. Good spectral resolution ensures close adjacent wavelengths can be resolved. Unlike dual view ICP-OES designs, the 710 Series covers all the important wavelengths in the visible region without compromise.*

*Excellent long-term stability from an optimized optical design. The grating and prism are fixed and the echelle polychromator is fully thermostatted, providing a reliable, no-moving-parts design that does not require correction lamps.*

*Computer controlled mirrors enable the plasma viewing position to be optimized.*

*A precision prism cross-disperser provides excellent performance across the wavelength range.*

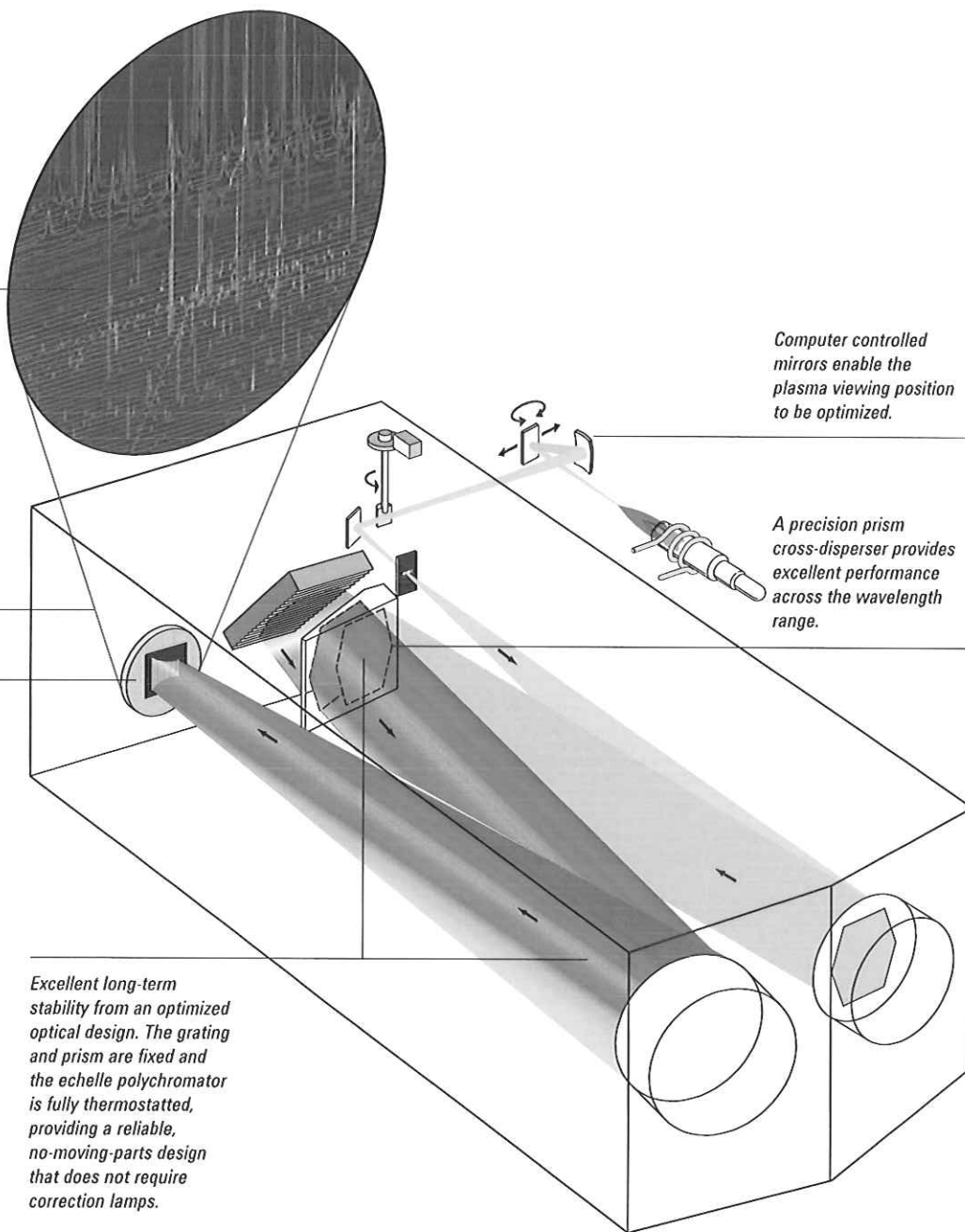

# THE COMBINED BENEFITS OF TWO LEADERS IN ATOMIC SPECTROSCOPY

With the 2010 addition of Varian, Inc., Agilent now offers an even greater range of instrumentation and the most comprehensive columns and supplies portfolio in the market. Just as important are the best-in-class service and technical support teams, focused on finding solutions for our customers. Agilent is here to provide the technology — and *the Measure of Confidence* — you need to be successful.

## An expanded portfolio of solutions from the leader in ICP-MS

The range of Agilent AA, ICP-OES and ICP-MS instruments offers unmatched performance, and the highest level of reliability and ease-of-use. The instruments are backed by a combined global network of dedicated and experienced support staff.

Agilent 7700 Series ICP-MS offers unmatched matrix tolerance and interference removal, and the smallest footprint of any ICP-MS.



Agilent's AA range includes the world's fastest flame AA and the world's most sensitive furnace AA.



Our catalog of new applications  
is ever growing.

To learn about the latest, contact your  
local Agilent Representative or visit us at:  
[www.agilent.com/chem/](http://www.agilent.com/chem/)

Find out how Agilent's  
Atomic Spectroscopy Solutions can  
deliver the productivity, reliability  
and accuracy you need.

Learn more: [www.agilent.com/chem](http://www.agilent.com/chem)

Buy online: [www.agilent.com/chem/store](http://www.agilent.com/chem/store)

Find an Agilent customer center in your country:  
[www.agilent.com/chem/contactus](http://www.agilent.com/chem/contactus)

U.S. and Canada

1-800-227-9770

[agilent\\_inquiries@agilent.com](mailto:agilent_inquiries@agilent.com)

Europe

[info\\_agilent@agilent.com](mailto:info_agilent@agilent.com)

Asia Pacific

[adinquiry\\_aplsca@agilent.com](mailto:adinquiry_aplsca@agilent.com)

Availability of chemicals dependent upon import restrictions.

This information is subject to change without notice.

© Agilent Technologies, Inc. 2010

Printed in U.S.A., September, 2010

5990-6496EN

The Measure of Confidence



Agilent Technologies





## Agilent 710 Series ICP-OES

Accurate. Robust. Reliable.

### Specifications

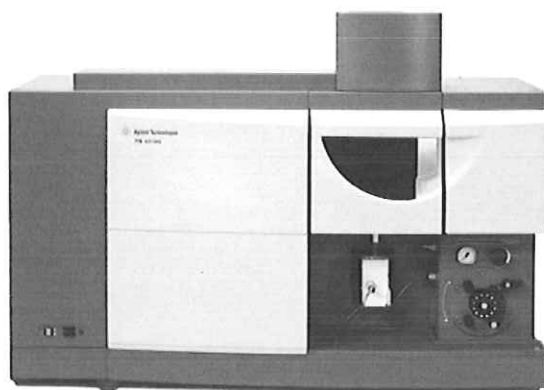

#### Introduction

Agilent 710 Series ICP-OES spectrometers are manufactured according to a quality management system certified to ISO 9001.

#### Design overview

The Agilent 710 and 715 ICP-OES systems are patented compact, bench-mounted simultaneous Inductively Coupled Plasma Optical Emission Spectrometers (ICP-OES) with full PC control of instrument settings and compatible accessories. They feature an innovative megapixel CCD detector designed specifically for ICP-OES and provide complete wavelength coverage from 177–785 nm.

Agilent ICP-OES systems are available in either axially (710) or radially (715) viewed configurations and include a free-running, air-cooled 40 MHz RF generator with solid-state HV power supply, purged echelle polychromator and full PC control of plasma viewing position and plasma gas flows. Fully web-integrated ICP-Expert II software uses Agilent's worksheet concept for ease of use, rapid operator training, and commonality with other Agilent spectroscopy products.



## Instrument hardware

### Sample introduction

Choice of optimized axial (710) or radial (715) configurations to suit your application needs.

- 715 includes an inert and robust, double-pass cyclone spraychamber and V-groove nebulizer as standard
- 710 includes a high sensitivity glass, single-pass cyclone spraychamber and Conikal nebulizer as standard
- Fully PC-controlled peristaltic pump, variable speed from 0–50 rpm, three channels for sample, drain and internal standard/ionization buffer
- Optional semi and fully-demountable torches with choice of glass or ceramic injector tubes, patented<sup>2</sup> high solids torch and all-glass sample introduction system

### Gas control

Plasma and auxiliary gas flows are software controlled using switched flow controllers. The system is fully interlocked against gas failure.

- Nebulizer gas: software enabled with choice of flow control using a high precision pressure regulator, or computer controlled using mass flow control. MFC provides flow range 0–1.3 L/min in 0.01 L/min increments
- Plasma gas: 0–22.5 L/min in 1.5 L/min increments
- Auxiliary gas: 0–2.25 L/min in 0.75 L/min increments

### RF generator

- 40 MHz free-running, air-cooled RF generator. Power output of 700–1700 W in 50 W increments. Optimum power settings defined and stored within each method for different sample types  
Over 75% RF coupling efficiency  
Automatic ignition and shutdown with user-customizable ignition sequence
- Power output stability is better than 0.1%

### Plasma configuration

#### Radially viewed system (715 ICP-OES)

Vertically oriented, radially viewed plasma is ideal for the most difficult of applications, including the analysis of oils and organic solvents, chemicals, metals and brines. Includes full PC control of plasma viewing height from 0–20 mm and horizontal adjustment of  $\pm 3$  mm to optimize sensitivity and minimize interferences. Viewing height may be adjusted under PC control for each wavelength of interest.

#### Axially Viewed System (710 ICP-OES)

Horizontally oriented, axially viewed plasma is ideal for high sensitivity analyses. Provides a 5–10 fold improvement in detection limits compared to radial viewing. The axially viewed plasma system features a unique Cooled Cone Interface (CCI) to prevent the cooler plasma tail from being viewed by the optics. This reduces interferences, improves the system's tolerance to high dissolved solids and extends the linear dynamic range compared to conventional axial systems.

The CCI is a superior plasma interface with lower running costs compared to shear gas systems. Includes full X, Y adjustment of plasma viewing position under PC control

# Agilent 710 Series ICP-OES

## Instrument hardware

### Optical system

- Computer-optimized echelle optical design with no moving optical parts ensures lowest detection limits and maximum stability
- 400 mm focal length polychromator is thermostatted to 35 °C for excellent stability. Features a precision prism cross disperser and echelle grating (94.74 lines/mm) creating an echellogram (of 70 orders) that is projected onto the megapixel CCD detector
- Standard polychromator purge of 0.75 L/min with PC controlled 3 L/min boost purge for operation with emission lines having wavelengths below 185 nm. Can be purged with either nitrogen\* or argon (\*requires optional nitrogen purge kit)

### Megapixel CCD detector

- Innovative megapixel CCD detector features 1.12 million pixels, each 15 µm x 15 µm in an X-Y grid array for full wavelength coverage from 177 nm to 785 nm. The detector is thinned and back illuminated for enhanced Quantum Efficiency (QE) in the UV. The detector is mounted on a two stage Peltier device and cooled to -30 °C for low dark current and noise
- Auto Integration allows intense and trace signals to be measured simultaneously at the optimum signal-to-noise ratio, providing lowest possible detection limits and preventing over-range signals – more intense peaks are allocated shorter integration times and less intense peaks are allocated longer times
- The megapixel CCD detector features anti-blooming protection on each pixel. This enables the simultaneous measurement of trace level analytes in the presence of nearby intense signals

## Instrument software

### Features

ICP-Expert II is an easy-to-use, web-integrated instrument software package. Features wizards that guide users through method and sequence development and method templates for rapid development of commonly used methods

- Computer control of plasma gas flows, plasma viewing position, ignition, RF power, safety interlocks and utilities monitoring
- Choice of background correction techniques from traditional off-peak background correction to unique fitted background correction
- Patented Fast Automated Curve-fitting Technique (FACT) for online spectral deconvolution of complex spectra
- MultiCal assists in extending linear dynamic range and automatic validation of results
- Number of replicates measured can be set by solution type (calibration standards, QC solutions, samples)
- Calibration routines for multi-element external calibration and method of standard addition
- Calibration reslopes eliminate the need for full re-calibration
- User-customizable Quality Control Protocols (QCP) designed to meet US EPA and other international compliance standards
- Fully editable sample label list with optional customer and batch label fields
- Weight/volume/dilution correction factors with user-definable concentration units conversion for samples and calibration/QC solutions
- Autosampler rack and tube positions can be edited for true random access sampling
- Sequence options include calibration/reslope/QCP error actions and end of analysis actions

## Instrument software

### Features

- Calibrations can be programmed at a user-specified rate either inline with sample tubes or from centralized calibration tubes (rate-driven)
- Microsoft's SQL Server 2005 Express for secure storage and fast retrieval of results
- Real-time graphical display of signal spectra, results and calibration graphs
- Post-run retrospective data editing
- Wide variety of reporting and exporting options with user-defineable settings
- Graphical display of system status and comprehensive set of instrument diagnostic tools
- Comprehensive help system, including multimedia and video assistance

## Analytical Performance

### Stray light

Stray light elimination via baffles and optical design to less than 2.0 mg/L effective As signal at 188.980 nm from 10 000 mg/L Ca

### Signal stability

Typically stable to less than 1% RSD over 8 hours without internal standardization or any form of drift correction

### Typical resolution (FWHM)

Element	Wavelength (nm)	Resolution (pm)
As	188.980	<9
Mo	202.032	<9
Zn	213.857	<10
Cr	267.716	<13
Cu	327.396	<19
Ba	614.172	<45

# Agilent 710 Series ICP-OES

## Analytical Performance

### Typical detection limits

3 sigma detection limits (µg/L) using a 30 second integration time

Element	Wavelength (nm)	715 radial (µg/L)	710 axial (µg/L)	Element	Wavelength (nm)	715 radial (µg/L)	710 axial (µg/L)
Ag	328.068	1	0.5	Mg	279.553	0.1	0.02
Al	396.152	4	0.9	Mn	257.610	0.15	0.05
As	188.980	12	2	Mo	202.032	2	0.5
Au	242.794	5	1	Na	589.592	1.5	0.2
B	249.772	1.5	0.3	Ni	231.604	2.1	0.7
Ba	455.403	0.15	0.03	P	177.434	15	3
Be	313.107	0.15	0.03	Pb	220.353	8	1.5
Bi	223.061	10	2.5	S	181.972	13	4
Ca	396.847	0.3	0.01	Sb	206.834	15	3
Cd	214.439	0.5	0.08	Se	196.026	16	4
Ce	418.659	7	2	Si	251.611	5	2
Co	238.892	1.2	0.3	Sn	189.927	10	1.6
Cr	267.716	1	0.2	Sr	407.771	0.1	0.02
Cu	324.754	1.5	0.5	Ti	334.941	0.5	0.5
Fe	238.204	0.9	0.2	Tl	190.794	10	2
Hg	184.887	2.5	0.9	V	292.401	2	0.5
K	766.491	4	0.3	Zn	213.857	0.8	0.2
Li	670.783	1	0.06	Zr	343.823	1.5	0.3

## Accessories

### Autosampler

- Agilent SPS 3 high throughput autosampler, with fast X, Z, theta arm movement
- Capacity for up to three sample racks and two standard racks. Racks may be exchanged during analysis for unlimited sample capacity
- Fully compatible with optional online diluter
- Compatible with a wide range of commercially available, autoclavable, laboratory racks

### Diluter

- Optional precision syringe auto-diluter for Agilent SPS 3, performs automatic online over-range dilution and automatic off-line sample and calibration solution preparation using optional software

### Automatic online dilution

- Online dilution of over-range elements with user-definable dilution and mixing options
- Serial dilution of samples until analyte results are in-range
- Combine with MultiCal to further extend the linear dynamic range

## Accessories

### Intelligent off-line solution preparation

- Optional RoboPrep software utility allows off-line dilution and preparation of samples and standards
- Provides customization of rack configurations to allow dilution of samples directly in digestion racks
- Includes capabilities for preparation of multi-element calibration standards, sample spiking and standard addition

### Productivity Package

- Four port Switching Valve System (SVS) immediately rinses the sample introduction system while the next sample is being introduced to the instrument
- Reduces carry-over, increases sample throughput and decreases cost per analysis

### Ultrasonic nebulizer

- USN accessory increases nebulization efficiency typically providing an order-of-magnitude improvement in detection limits

### Vapor generation

- Modular continuous flow vapor generator for the determination of Hg, As, Se, Sb, Te, Bi, and Sn at  $\mu\text{g/L}$  and  $\text{ng/L}$  levels
- Compatible with the Agilent SPS 3 autosampler

### AGM-1

- Adds oxygen to the plasma to prevent carbon deposition and reduce background structure when analyzing organic solvents

### Volatile organics kit

- Includes a water-cooled spraychamber and demountable torch with 0.8 mm ID injector for the analysis of volatile organics such as gasoline and naphtha
- Requires, but does not include a suitable water cooler. The AGM-1 for controlled addition of oxygen to the auxiliary gas is also recommended

### Torches, nebulizers and spare

Agilent offers a range of torches, nebulizers, spraychambers, tubings and other spares. Refer to our web site for details

**For more information**

Visit [www.agilent.com/chem/](http://www.agilent.com/chem/)

**[www.agilent.com/chem](http://www.agilent.com/chem)**

Agilent shall not be liable for errors contained herein or for incidental or consequential damages in connection with the furnishing, performance or use of this material.

Information, descriptions, and specifications in this publication are subject to change without notice.

© Agilent Technologies, Inc. 2010  
Printed in XXX, XXX, 2010  
Publication number: SI-0287

The Measure of Confidence





# Agilent Technologies

Alan Cummings  
State of West Virginia  
190 Dry Branch Drive  
Charleston WV 25306

## Quotation

Quote No.	Create Date	Delivery Time	Page
1294938	11/05/2012	4 Weeks	1 of 5
Contact	Phone no.	Valid to	
Vic Gill	513-520-5861	01/04/2013	
To place an order: Call 1-800-227-9770 Option 1 For Instruments Fax : 302-633-8953 For Consumables Fax : 302-633-8901 Email : LSCAinstrumentsales@agilent.com For Genomics Fax : 512-321-3128 Email : orders@agilent.com For additional instructions, see last page			

State of West Virginia 7713005 11-07-2012  
2 days on site training included

Product/Description	Qty/Unit	Unit List Price	Discount Amount	Extended Net Price
<b>G8464AA</b> Agilent 710 axial viewed ICP-OES with mass flow controlled nebulizer, 3 channel pump, polychromator, Megapixel CCD, OneNeb nebulizer, glass cyclonic spraychamber, torch, PC and ICP Expert Software	1.000 EA	82,895.00 USD	33,158.00-	49,737.00
With the following configuration: Ship-to Country : USA Installation (44K) Familiarization at Installation (44L)				
<b>Item Total</b>				<b>49,737.00</b>
Special discount of 40.00 % is applied.				





# Quotation

Alan Cummings  
State of West Virginia  
190 Dry Branch Drive  
Charleston WV 25306

Quote No.	Create Date	Delivery Time	Page
1294938	11/05/2012	4 Weeks	2 of 5
Contact		Phone no.	Valid to
Vic Gill		513-520-5861	01/04/2013
To place an order: Call 1-800-227-9770 Option 1 For Instruments Fax : 302-633-8953 For Consumables Fax : 302-633-8901 Email : LSCAinstrumentsales@agilent.com For Genomics Fax : 512-321-3128 Email : orders@agilent.com			

Product/Description	Qty/Unit	Unit List Price	Discount Amount	Extended Net Price
---------------------	----------	-----------------	-----------------	--------------------

<b>6610030000</b>	1.000 EA	474.00 USD	189.60-	284.40
Bottle ICP-OES Wavecal conc 500mL 50 ppm Wavelength calibration conc. for 700 Series, Vista PRO + Vista MPX ICP. Incl. 50 ppm Al, As, Ba, Cd, Co, Cr, Cu, Mn, Mn, Mo, Ni, Pb, Se, Sr, Zn + 500 ppm K.				

**Item Total** 284.40

Special discount of 40.00 % is applied.

<b>G1879B</b>	1.000 EA	1,608.00 USD	643.20-	964.80
Heat exchanger PolyScience Model 3370 Air Cooled Recirculator				

With the following configuration:  
Ship-to Country : USA

**Item Total** 964.80

Special discount of 40.00 % is applied.



**Agilent Technologies**

Alan Cummings  
 State of West Virginia  
 190 Dry Branch Drive  
 Charleston WV 25306

# Quotation

Quote No.	Create Date	Delivery Time	Page
1294938	11/05/2012	4 Weeks	3 of 5
Contact	Phone no.	Valid to	
Vic Gill	513-520-5861	01/04/2013	
To place an order: Call 1-800-227-9770 Option 1 For Instruments Fax : 302-633-8953 For Consumables Fax : 302-633-8901 Email : LSCAinstrumentsales@agilent.com For Genomics Fax: 512-321-3128 Email : orders@agilent.com			

Product/Description	Qty/Unit	Unit List Price	Discount Amount	Extended Net Price
190065000 QCStd-27 Quality Control StandardHAZ	1.000 EA	470.00 USD	188.00-	282.00
<b>Item Total</b>				<b>282.00</b>
Special discount of 40.00 % is applied.				
6610030400 Bottle ICP Internal Std Mix 125mL 100ppm	1.000 EA	254.00 USD	101.60-	152.40
<b>Item Total</b>				<b>152.40</b>
Special discount of 40.00 % is applied.				
9910124100 Kit, ICP-ES, interl std B, (OE/WE), 1/pk Provides components required for on-line addition of internal standard solution. Includes orange/white PVC pump tubes, Y-piece + connecting tubing.	1.000 EA	553.00 USD		553.00
<b>Item Total</b>				<b>553.00</b>



**Agilent Technologies**

Alan Cummings  
State of West Virginia  
190 Dry Branch Drive  
Charleston WV 25306

# Quotation

Quote No.	Create Date	Delivery Time	Page
1294938	11/05/2012	4 Weeks	4 of 5
Contact	Phone no.	Valid to	
Vic Gill	513-520-5861	01/04/2013	
To place an order: Call 1-800-227-9770 Option 1 For Instruments Fax : 302-633-8953 For Consumables Fax : 302-633-8901 Email : LSCAinstrumentsales@agilent.com For Genomics Fax: 512-321-3128 Email : orders@agilent.com			

Product/Description	Qty/Unit	Unit List Price	Discount Amount	Extended Net Price
---------------------	----------	-----------------	-----------------	--------------------

Gross Amount	:	\$	86,254.00
Total Discount	:	\$	34,280.40
<b>Total</b>	:	<b>\$</b>	<b>51,973.60</b>



Alan Cummings  
State of West Virginia  
190 Dry Branch Drive  
Charleston WV 25306

Quote No.	Create Date	Delivery Time	Page
1294938	11/05/2012	4 Weeks	5 of 5
Contact		Phone no.	Valid to
Vic Gill		513-520-5861	01/04/2013
To place an order: Call 1-800-227-9770 Option 1 For Instruments Fax : 302-633-8953 For Consumables Fax : 302-633-8901 Email : LSCAinstrumentsales@agilent.com For Genomics Fax: 512-321-3128 Email : orders@agilent.com			

TO PLACE AN ORDER, Agilent offers several options:

- 1) Visit <http://www.agilent.com/chem/supplies> to place online orders using a purchase order or credit card.
- 2) Call 1-800-227-9770 (option 1) any weekday between 8am and 8 pm Eastern time in the U.S., Canada & Puerto Rico.
- 3) To place an order for Consumables, please fax the order to 302-633-8901.  
To place an instrument and/or software order, please fax the order to 302-633-8953.  
To place an order for Genomics, please fax the order to 512-321-3128, or email to orders@agilent.com
- 4) Or you can mail your order to:  
Agilent Technologies  
North American Customer Contact Center  
2850 Centerville Road BU3-2  
Wilmington, DE 19808-1610

To place an order, the following information is required:

- Purchase order number or credit card, delivery date, ship to, invoice to, end user, and quote number.
- GSA customers please provide GSA contract #.

EXCLUSIVE OFFERS FOR NEW INSTRUMENT CUSTOMERS, go to [www.agilent.com/chem/exclusiveoffers](http://www.agilent.com/chem/exclusiveoffers)

TO CHECK THE STATUS OF AN ORDER:

- 1) Visit <http://www.agilent.com/chem/supplies> to check the status of your order.
- 2) Call 1-800-227-9770 (option 1) any weekday between 8 am and 8 pm Eastern time, in the U.S., Canada & Puerto Rico. You will need to know the purchase order or credit card number the order was placed on.

FINANCING AND LEASING - A wide range of options are available from Agilent's preferred financing partner, Leasing Group Inc. (LGI).

For more information or to discuss how monthly payments could suit your operational or budgetary requirements, contact your Agilent Account Manager or contact LGI at 800-944-1370.

**TERMS AND CONDITIONS:**

- Pricing: Web prices are provided only for the U.S. in U.S.dollars. All phone prices are in local currency and for end use. Applicable local taxes are applied.
- All Sales Tax is subject to change at the time of order.
- Shipping and Handling Charges: Orders with a value less than \$2000 or those requiring special services such as overnight delivery may be subject to additional shipping & handling fees. Some of these charges may be avoided by ordering via the Web
- Payment Terms: Net 30 days from invoice date, subject to credit approval.

\* Quotation Validity: This quotation is valid for 60 days unless otherwise indicated.

\* Warranty period for instrumentation is 1 year. The Warranty period for columns and consumables is 90 days.

It is Agilent Technologies intent to ship product at the earliest available date unless specified otherwise.

The sale of standard Products and Services referenced in this quotation is subject to the then current version of Agilent's Terms of Sale, and any LSCA Supplemental Terms or other applicable terms referenced herein. If any Products or Services are manufactured, configured or adapted to meet Customer's requirements, the sale of all Products and Services referenced in this quotation is subject to the then current version of Agilent's Terms of Sale for Custom Products and any LSCA Supplemental Terms or other applicable terms referenced herein. A copy of Agilent's Terms of Sale, Agilent's Terms of Sale for Custom Products and the LSCA Supplemental Terms is either attached or has been previously provided to you. Please contact us if you have not received a copy or require an additional copy. If you have a separate agreement in effect with Agilent covering the sale of Products and Services referenced in this quotation, the terms of that agreement will apply to those Products and Services. Agilent expressly objects to any different or additional terms in your purchase/sales order documentation, unless agreed to in writing by Agilent. Product and Service availability dates are estimated at the time of the quotation. Actual delivery dates or delivery windows will be specified at the time Agilent acknowledges and accepts your purchase order. The above conditions shall apply to the fullest extent permitted by the law. You may have other statutory or legal rights available. Commodities, technology or software exported from the United States of America ("U.S.") or from other exporting countries will be subject to the U.S. Export Administration Regulations and all exporting countries' export laws and regulations. Diversion contrary to U.S. law and the applicable export laws and regulations is prohibited.

State of West Virginia  
**VENDOR PREFERENCE CERTIFICATE**

Certification and application\* is hereby made for Preference in accordance with *West Virginia Code*, §5A-3-37. (Does not apply to construction contracts). *West Virginia Code*, §5A-3-37, provides an opportunity for qualifying vendors to request (at the time of bid) preference for their residency status. Such preference is an evaluation method only and will be applied only to the cost bid in accordance with the *West Virginia Code*. This certificate for application is to be used to request such preference. The Purchasing Division will make the determination of the Resident Vendor Preference, if applicable.

1. **Application is made for 2.5% resident vendor preference for the reason checked:**  
 Bidder is an individual resident vendor and has resided continuously in West Virginia for four (4) years immediately preceding the date of this certification; or,  
 Bidder is a partnership, association or corporation resident vendor and has maintained its headquarters or principal place of business continuously in West Virginia for four (4) years immediately preceding the date of this certification; or 80% of the ownership interest of Bidder is held by another individual, partnership, association or corporation resident vendor who has maintained its headquarters or principal place of business continuously in West Virginia for four (4) years immediately preceding the date of this certification; or,  
 Bidder is a nonresident vendor which has an affiliate or subsidiary which employs a minimum of one hundred state residents and which has maintained its headquarters or principal place of business within West Virginia continuously for the four (4) years immediately preceding the date of this certification; or,
2. **Application is made for 2.5% resident vendor preference for the reason checked:**  
 Bidder is a resident vendor who certifies that, during the life of the contract, on average at least 75% of the employees working on the project being bid are residents of West Virginia who have resided in the state continuously for the two years immediately preceding submission of this bid; or,
3. **Application is made for 2.5% resident vendor preference for the reason checked:**  
 Bidder is a nonresident vendor employing a minimum of one hundred state residents or is a nonresident vendor with an affiliate or subsidiary which maintains its headquarters or principal place of business within West Virginia employing a minimum of one hundred state residents who certifies that, during the life of the contract, on average at least 75% of the employees or Bidder's affiliate's or subsidiary's employees are residents of West Virginia who have resided in the state continuously for the two years immediately preceding submission of this bid; or,
4. **Application is made for 5% resident vendor preference for the reason checked:**  
 Bidder meets either the requirement of both subdivisions (1) and (2) or subdivision (1) and (3) as stated above; or,
5. **Application is made for 3.5% resident vendor preference who is a veteran for the reason checked:**  
 Bidder is an individual resident vendor who is a veteran of the United States armed forces, the reserves or the National Guard and has resided in West Virginia continuously for the four years immediately preceding the date on which the bid is submitted; or,
6. **Application is made for 3.5% resident vendor preference who is a veteran for the reason checked:**  
 Bidder is a resident vendor who is a veteran of the United States armed forces, the reserves or the National Guard, if, for purposes of producing or distributing the commodities or completing the project which is the subject of the vendor's bid and continuously over the entire term of the project, on average at least seventy-five percent of the vendor's employees are residents of West Virginia who have resided in the state continuously for the two immediately preceding years.
7. **Application is made for preference as a non-resident small, women- and minority-owned business, in accordance with *West Virginia Code* §5A-3-59 and *West Virginia Code of State Rules*.**  
 Bidder has been or expects to be approved prior to contract award by the Purchasing Division as a certified small, women- and minority-owned business.

Bidder understands if the Secretary of Revenue determines that a Bidder receiving preference has failed to continue to meet the requirements for such preference, the Secretary may order the Director of Purchasing to: (a) reject the bid; or (b) assess a penalty against such Bidder in an amount not to exceed 5% of the bid amount and that such penalty will be paid to the contracting agency or deducted from any unpaid balance on the contract or purchase order.

By submission of this certificate, Bidder agrees to disclose any reasonably requested information to the Purchasing Division and authorizes the Department of Revenue to disclose to the Director of Purchasing appropriate information verifying that Bidder has paid the required business taxes, provided that such information does not contain the amounts of taxes paid nor any other information deemed by the Tax Commissioner to be confidential.

Under penalty of law for false swearing (*West Virginia Code*, §61-5-3), Bidder hereby certifies that this certificate is true and accurate in all respects; and that if a contract is issued to Bidder and if anything contained within this certificate changes during the term of the contract, Bidder will notify the Purchasing Division in writing immediately.

Bidder: \_\_\_\_\_ Signed: \_\_\_\_\_

Date: \_\_\_\_\_ Title: \_\_\_\_\_

STATE OF WEST VIRGINIA  
Purchasing Division

**PURCHASING AFFIDAVIT**

West Virginia Code §5A-3-10a states: No contract or renewal of any contract may be awarded by the state or any of its political subdivisions to any vendor or prospective vendor when the vendor or prospective vendor or a related party to the vendor or prospective vendor is a debtor and the debt owed is an amount greater than one thousand dollars in the aggregate.

**DEFINITIONS:**

"Debt" means any assessment, premium, penalty, fine, tax or other amount of money owed to the state or any of its political subdivisions because of a judgment, fine, permit violation, license assessment, defaulted workers' compensation premium, penalty or other assessment presently delinquent or due and required to be paid to the state or any of its political subdivisions, including any interest or additional penalties accrued thereon.

"Debtor" means any individual, corporation, partnership, association, limited liability company or any other form or business association owing a debt to the state or any of its political subdivisions. "Political subdivision" means any county commission; municipality; county board of education; any instrumentally established by a county or municipality; any separate corporation or instrumentally established by one or more counties or municipalities, as permitted by law; or any public body charged by law with the performance of a government function or whose jurisdiction is coextensive with one or more counties or municipalities. "Related party" means a party, whether an individual, corporation, partnership, association, limited liability company or any other form or business association or other entity whatsoever, related to any vendor by blood, marriage, ownership or contract through which the party has a relationship of ownership or other interest with the vendor so that the party will actually or by effect receive or control a portion of the benefit, profit or other consideration from performance of a vendor contract with the party receiving an amount that meets or exceeds five percent of the total contract amount.

**EXCEPTION:** The prohibition of this section does not apply where a vendor has contested any tax administered pursuant to chapter eleven of this code, workers' compensation premium, permit fee or environmental fee or assessment and the matter has not become final or where the vendor has entered into a payment plan or agreement and the vendor is not in default of any of the provisions of such plan or agreement.

Under penalty of law for false swearing (*West Virginia Code §61-5-3*), it is hereby certified that the vendor affirms and acknowledges the information in this affidavit and is in compliance with the requirements as stated.

**WITNESS THE FOLLOWING SIGNATURE**

Vendor's Name: Agilent Technologies, Inc.

Authorized Signature: \* Off-Hayes \* To the best of my knowledge. Date: Nov. 5, 2012

State of Delaware

County of New Castle, to-wit:

Taken, subscribed, and sworn to before me this 5 day of November, 2012.

My Commission expires July 6, 2016.

AFFIX SEAL HERE

NOTARY PUBLIC Shirley B. Lamkin

