



State of West Virginia
 Department of Administration
 Purchasing Division
 2019 Washington Street East
 Post Office Box 50130
 Charleston, WV 25305-0130

Solicitation

| |
|----------|
| NUMBER |
| 08130144 |

| |
|------|
| PAGE |
| 1 |

ADDRESS CORRESPONDENCE TO ATTENTION OF:
 ALAN CUMMINGS
 304-558-2402

VENDOR

*709060129 304-766-6601
 CHARLESTON STEEL
 511 28TH ST
 PO BOX 547
 DUNBAR WV 25064

SHIP TO

DIVISION OF HIGHWAYS
 DISTRICT EIGHT
 US 219, NORTH PARSONS ROAD
 PO BOX 1516
 ELKINS, WV
 26241 304-637-0228

| |
|--------------|
| DATE PRINTED |
| 01/22/2013 |

BID OPENING DATE: 02/13/2013 BID OPENING TIME 1:30PM

| LINE | QUANTITY | UOP | CAT. NO. | ITEM NUMBER | UNIT PRICE | AMOUNT |
|--|----------|-----|----------|-------------|------------|--------------------|
| 0001 | | LS | | 570-84 | | |
| STEEL: STRUCTURAL SHAPES; ANGLE, CHANNEL, ETC. | | | | | | |
| THE WEST VIRGINIA STATE PURCHASING DIVISION FOR THE AGENCY, THE WEST VIRGINIA DIVISION OF HIGHWAYS, IS SOLICITING BIDS TO PROVIDE THE AGENCY WITH GALVANIZED STRUCTURAL STEEL PER THE ATTACHED SPECIFICATIONS. | | | | | | |
| ***** THIS IS THE END OF RFQ 08130144 ***** TOTAL: | | | | | | <u>\$39,511.97</u> |

02/13/13 09:38:02 AM
 West Virginia Purchasing Division

| | | |
|------------------------------------|---------------------------|-----------------------------------|
| SIGNATURE <i>Ernest Supples</i> | TELEPHONE 304-766-6607 | DATE 2/12/13 |
| TITLE <i>Mgr Warehouse</i> | FEIN 20-5496272 | ADDRESS CHANGES TO BE NOTED ABOVE |

WHEN RESPONDING TO SOLICITATION, INSERT NAME AND ADDRESS IN SPACE ABOVE LABELED 'VENDOR'

Pricing Page
RFQ #08130144

| Item Number | Quantity | Unit of Measure | Description | Unit Price | Total |
|-------------|----------|-----------------|--|------------|--------------|
| 1 | 26,038 | lb | W24x68, Galvanized W-shaped Structural Steel, AASHTO M270, Grade 50 Ship 10 pcs @ 38'-3½" fabricated in accordance with Sketch #1 | \$1.05 | \$ 27,339.90 |
| 2 | 2000 | lb | C12x25, Galvanized Structural Steel Channel, AASHTO M270, Grade 50 Ship 4 pcs @ 20'-0" | \$1.18 | \$ 2,360.00 |
| 3 | 648 | lb | L 6"x4"x ½" (16.2#/LF) Galvanized Structural Steel Angle, AASHTO M270, Grade 50 Ship 2 pcs @ 20'-0" fabricated in accordance with Sketch #2 | \$1.27 | \$ 822.96 |
| 4 | 648 | lb | L 6"x4"x ½" (16.2#/LF) Galvanized Structural Steel Angle, AASHTO M270, Grade 50 Ship 2 pcs @ 20'-0" fabricated in accordance with Sketch #3 | \$1.27 | \$ 822.96 |
| 5 | 640 | lb | L 4"x4"x ½" (12.8#/LF) Galvanized Structural Steel Angle, AASHTO M270, Grade 50 Ship 50 pcs @ 1'-0" fabricated in accordance with Sketch #5 | \$2.20 | \$ 1408.00 |
| 6 | 320 | lb | L 4"x4"x ½" (12.8#/LF) Galvanized Structural Steel Angle, AASHTO M270, Grade 50 Ship 25 pcs @ 1'-0" fabricated in accordance with Sketch #6 | \$2.20 | \$ 704.00 |
| 7 | 2819 | lb | HSS 6"x6"x½" Galv. Structural Steel Tubing (35.24 #/LF), ASTM A500 Ship 4 pcs @ 20'-0" fabricated in accordance with Sketch #4 | \$1.05 | \$ 2959.95 |
| 8 | 1224 | lb | ¾" x 6" Galvanized Structural Steel Bar (15.3 #/LF), AASHTO M270, Grade 50 Ship 4 pcs @ 20'-0" fabricated in accordance with Sketch #7 | \$1.21 | \$1481.04 |
| 9 | 342 | lb | ⅝" x 6" Galvanized Structural Steel Bar (17.9 #/LF), AASHTO M270, Grade 50 Ship 9 pcs @ 2'-1½" fabricated in accordance with Sketch #8 | \$2.48 | \$ 848.16 |
| 10 | 425 | lb | ¾" x 6" Galvanized Structural Steel Bar (15.3 #/LF), AASHTO M270, Grade 50 Ship 9 pcs @ 3'-1" fabricated in accordance with Sketch #8 | \$1.80 | \$ 765.00 |
| | 35,104 | | Grand Total  | | \$39,511.97 |

VENDOR PREFERENCE CERTIFICATE

Certification and application* is hereby made for Preference in accordance with *West Virginia Code*, §5A-3-37. (Does not apply to construction contracts). *West Virginia Code*, §5A-3-37, provides an opportunity for qualifying vendors to request (at the time of bid) preference for their residency status. Such preference is an evaluation method only and will be applied only to the cost bid in accordance with the *West Virginia Code*. This certificate for application is to be used to request such preference. The Purchasing Division will make the determination of the Resident Vendor Preference, if applicable.

- 1. **Application is made for 2.5% resident vendor preference for the reason checked:**
 Bidder is an individual resident vendor and has resided continuously in West Virginia for four (4) years immediately preceding the date of this certification; **or,**
 Bidder is a partnership, association or corporation resident vendor and has maintained its headquarters or principal place of business continuously in West Virginia for four (4) years immediately preceding the date of this certification; **or** 80% of the ownership interest of Bidder is held by another individual, partnership, association or corporation resident vendor who has maintained its headquarters or principal place of business continuously in West Virginia for four (4) years immediately preceding the date of this certification; **or,**
 Bidder is a nonresident vendor which has an affiliate or subsidiary which employs a minimum of one hundred state residents and which has maintained its headquarters or principal place of business within West Virginia continuously for the four (4) years immediately preceding the date of this certification; **or,**
- 2. **Application is made for 2.5% resident vendor preference for the reason checked:**
 Bidder is a resident vendor who certifies that, during the life of the contract, on average at least 75% of the employees working on the project being bid are residents of West Virginia who have resided in the state continuously for the two years immediately preceding submission of this bid; **or,**
- 3. **Application is made for 2.5% resident vendor preference for the reason checked:**
 Bidder is a nonresident vendor employing a minimum of one hundred state residents or is a nonresident vendor with an affiliate or subsidiary which maintains its headquarters or principal place of business within West Virginia employing a minimum of one hundred state residents who certifies that, during the life of the contract, on average at least 75% of the employees or Bidder's affiliate's or subsidiary's employees are residents of West Virginia who have resided in the state continuously for the two years immediately preceding submission of this bid; **or,**
- 4. **Application is made for 5% resident vendor preference for the reason checked:**
 Bidder meets either the requirement of both subdivisions (1) and (2) or subdivision (1) and (3) as stated above; **or,**
- 5. **Application is made for 3.5% resident vendor preference who is a veteran for the reason checked:**
 Bidder is an individual resident vendor who is a veteran of the United States armed forces, the reserves or the National Guard and has resided in West Virginia continuously for the four years immediately preceding the date on which the bid is submitted; **or,**
- 6. **Application is made for 3.5% resident vendor preference who is a veteran for the reason checked:**
 Bidder is a resident vendor who is a veteran of the United States armed forces, the reserves or the National Guard, if, for purposes of producing or distributing the commodities or completing the project which is the subject of the vendor's bid and continuously over the entire term of the project, on average at least seventy-five percent of the vendor's employees are residents of West Virginia who have resided in the state continuously for the two immediately preceding years.
- 7. **Application is made for preference as a non-resident small, women- and minority-owned business, in accordance with *West Virginia Code* §5A-3-59 and *West Virginia Code of State Rules*.**
 Bidder has been or expects to be approved prior to contract award by the Purchasing Division as a certified small, women- and minority-owned business.

Bidder understands if the Secretary of Revenue determines that a Bidder receiving preference has failed to continue to meet the requirements for such preference, the Secretary may order the Director of Purchasing to: (a) reject the bid; or (b) assess a penalty against such Bidder in an amount not to exceed 5% of the bid amount and that such penalty will be paid to the contracting agency or deducted from any unpaid balance on the contract or purchase order.

By submission of this certificate, Bidder agrees to disclose any reasonably requested information to the Purchasing Division and authorizes the Department of Revenue to disclose to the Director of Purchasing appropriate information verifying that Bidder has paid the required business taxes, provided that such information does not contain the amounts of taxes paid nor any other information deemed by the Tax Commissioner to be confidential.

Under penalty of law for false swearing (*West Virginia Code*, §61-5-3), Bidder hereby certifies that this certificate is true and accurate in all respects; and that if a contract is issued to Bidder and if anything contained within this certificate changes during the term of the contract, Bidder will notify the Purchasing Division in writing immediately.

Bidder: CHARLESTON STEEL
Date: 2/12/13

Signed: *Dennis W. Kobayashi*
Title: Mgr Warehouse Sales

STATE OF WEST VIRGINIA
Purchasing Division**PURCHASING AFFIDAVIT**

West Virginia Code §5A-3-10a states: No contract or renewal of any contract may be awarded by the state or any of its political subdivisions to any vendor or prospective vendor when the vendor or prospective vendor or a related party to the vendor or prospective vendor is a debtor and the debt owed is an amount greater than one thousand dollars in the aggregate.

DEFINITIONS:

"Debt" means any assessment, premium, penalty, fine, tax or other amount of money owed to the state or any of its political subdivisions because of a judgment, fine, permit violation, license assessment, defaulted workers' compensation premium, penalty or other assessment presently delinquent or due and required to be paid to the state or any of its political subdivisions, including any interest or additional penalties accrued thereon.

"Debtor" means any individual, corporation, partnership, association, limited liability company or any other form or business association owing a debt to the state or any of its political subdivisions. "Political subdivision" means any county commission; municipality; county board of education; any instrumentality established by a county or municipality; any separate corporation or instrumentality established by one or more counties or municipalities, as permitted by law; or any public body charged by law with the performance of a government function or whose jurisdiction is coextensive with one or more counties or municipalities. "Related party" means a party, whether an individual, corporation, partnership, association, limited liability company or any other form or business association or other entity whatsoever, related to any vendor by blood, marriage, ownership or contract through which the party has a relationship of ownership or other interest with the vendor so that the party will actually or by effect receive or control a portion of the benefit, profit or other consideration from performance of a vendor contract with the party receiving an amount that meets or exceeds five percent of the total contract amount.

EXCEPTION: The prohibition of this section does not apply where a vendor has contested any tax administered pursuant to chapter eleven of this code, workers' compensation premium, permit fee or environmental fee or assessment and the matter has not become final or where the vendor has entered into a payment plan or agreement and the vendor is not in default of any of the provisions of such plan or agreement.

Under penalty of law for false swearing (*West Virginia Code §61-5-3*), it is hereby certified that the vendor affirms and acknowledges the information in this affidavit and is in compliance with the requirements as stated.

WITNESS THE FOLLOWING SIGNATUREVendor's Name: CHARLESTON STEELAuthorized Signature: *Dennis R. Nicholas*
DENNIS R. NICHOLASDate: 2/12/13State of WEST VIRGINIACounty of KANAWHA, to-wit:Taken, subscribed, and sworn to before me this 12TH day of FEBRUARY, 2013.My Commission expires JANUARY 30, 2021.

AFFIX SEAL HERE

NOTARY PUBLIC

John E. Goetz IV

WV DEPT. OF TRANSPORTATION - DIVISION OF HIGHWAYS
DISTRICT 8, P.O. BOX 1516
ELKINS, WV 26241

RPO NO. 08130144
SKETCH #1

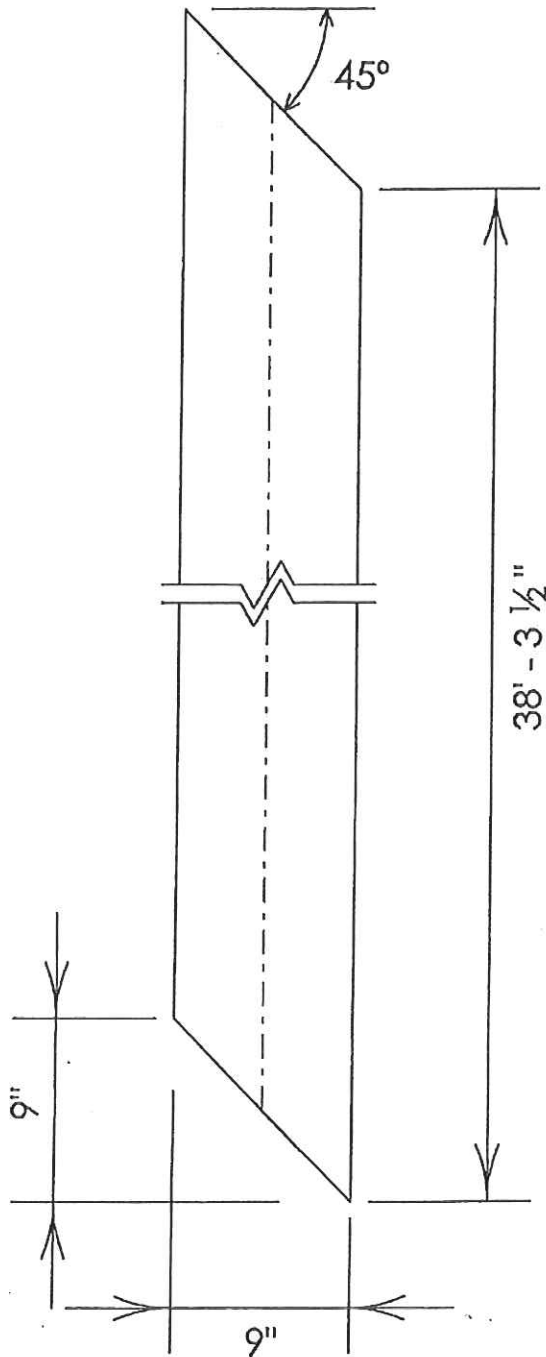

GALVANIZED W24x68 BEAM (Grade 50)

10 Required

WV DEPT. OF TRANSPORTATION - DIVISION OF HIGHWAYS
DISTRICT 8, P.O. BOX 1516
ELKINS, WV 26241

RPO NO. 08130144
SKETCH #2

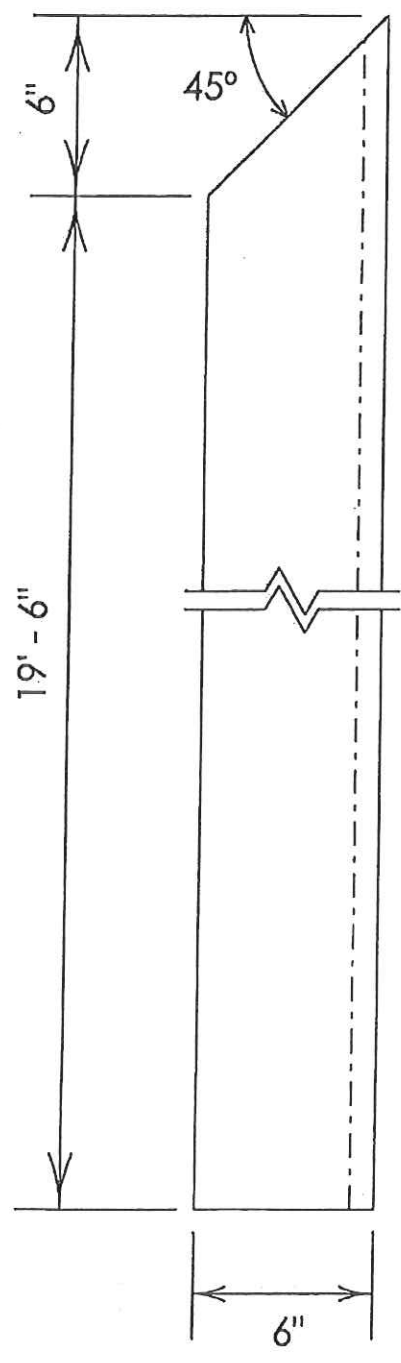

GALVANIZED L6"x4"x 1/2" ANGLE (Grade 50)
2 Required

WV DEPT. OF TRANSPORTATION - DIVISION OF HIGHWAYS
DISTRICT 8, P.O. BOX 1516
ELKINS, WV 26241

RPO NO. 08130144
SKETCH #3

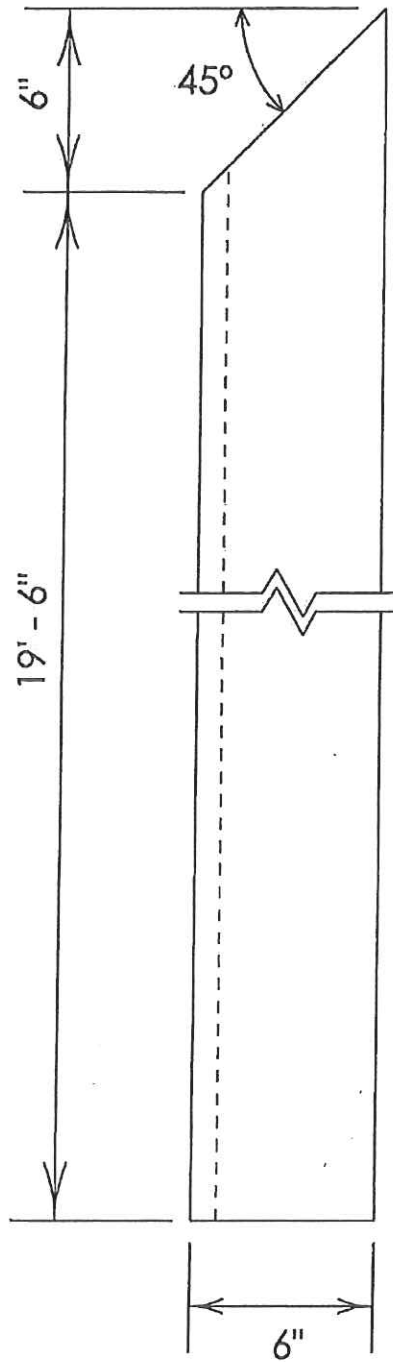

GALVANIZED L6"x4"x 1/2" ANGLE (Grade 50)

2 Required

WV DEPT. OF TRANSPORTATION - DIVISION OF HIGHWAYS
DISTRICT 8, P.O. BOX 1516
ELKINS, WV 26241

RPO NO. 08130144
SKETCH #4

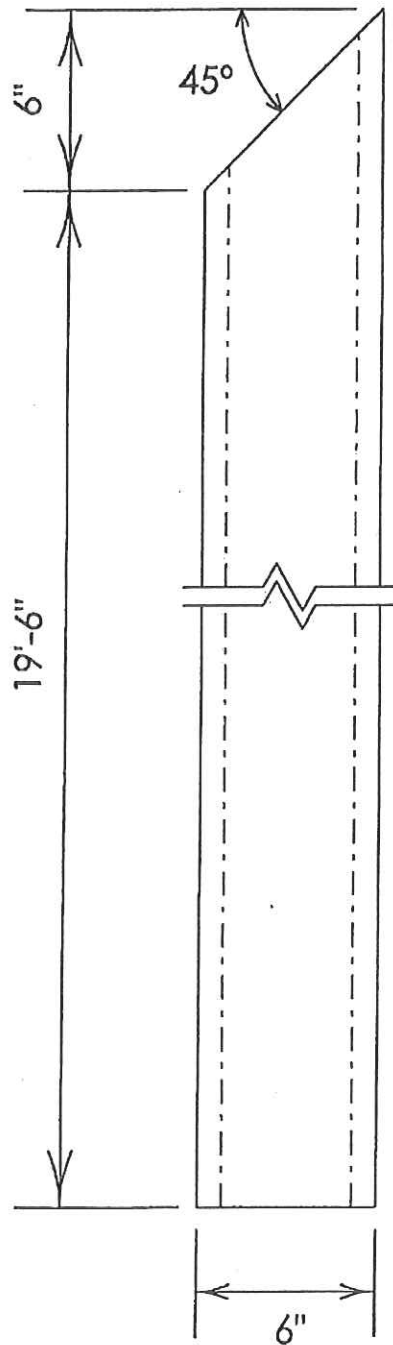

GALVANIZED 6"x6"x 1/2" TUBING (ASTM A500)

4 Required

WV DEPT. OF TRANSPORTATION - DIVISION OF HIGHWAYS
DISTRICT 8, P.O. BOX 1516
ELKINS, WV 26241

RPO NO. 08130144
SKETCH #5

ALL HOLES $1\frac{3}{16}$ " DIAMETER

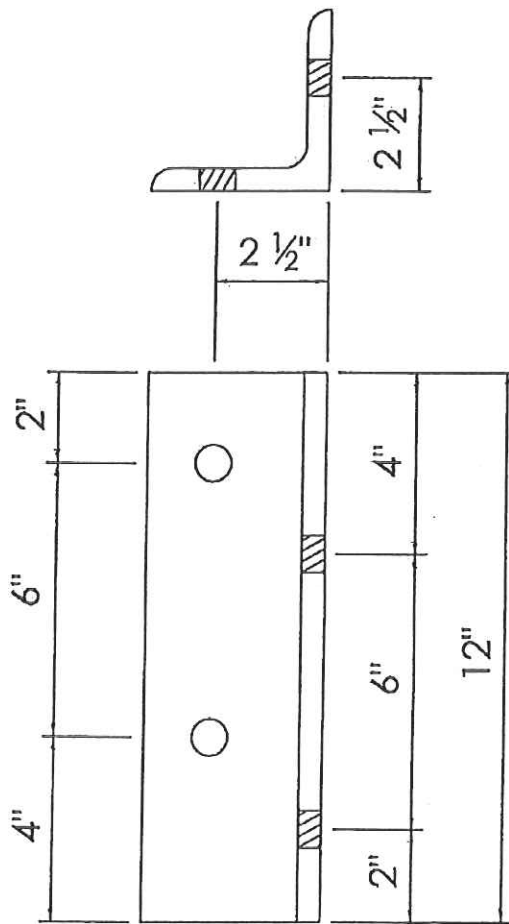

50 REQ'D

GALVANIZED CLIP ANGLE

ANGLE 4" x 4" x 1/2" - 50 REQUIRED

WV DEPT. OF TRANSPORTATION - DIVISION OF HIGHWAYS
DISTRICT 8, P.O. BOX 1516
ELKINS, WV 26241

RPO NO. 08130144
SKETCH #6

ALL HOLES $1\frac{3}{16}$ " DIAMETER

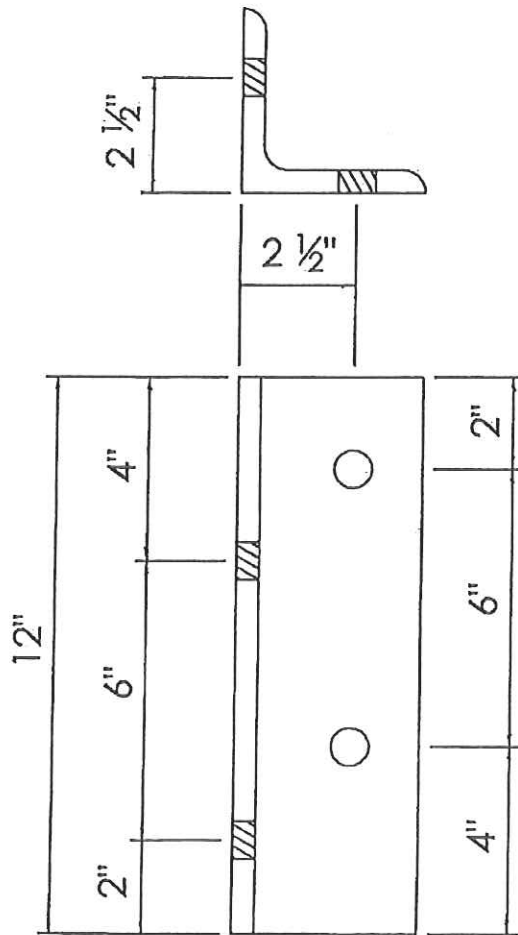

25

GALVANIZED CLIP ANGLE
ANGLE 4" x 4" x 1/2" - 25 REQUIRED

WV DEPT. OF TRANSPORTATION - DIVISION OF HIGHWAYS
DISTRICT 8, P.O. BOX 1516
ELKINS, WV 26241

RPO NO. 08130144
SKETCH #7

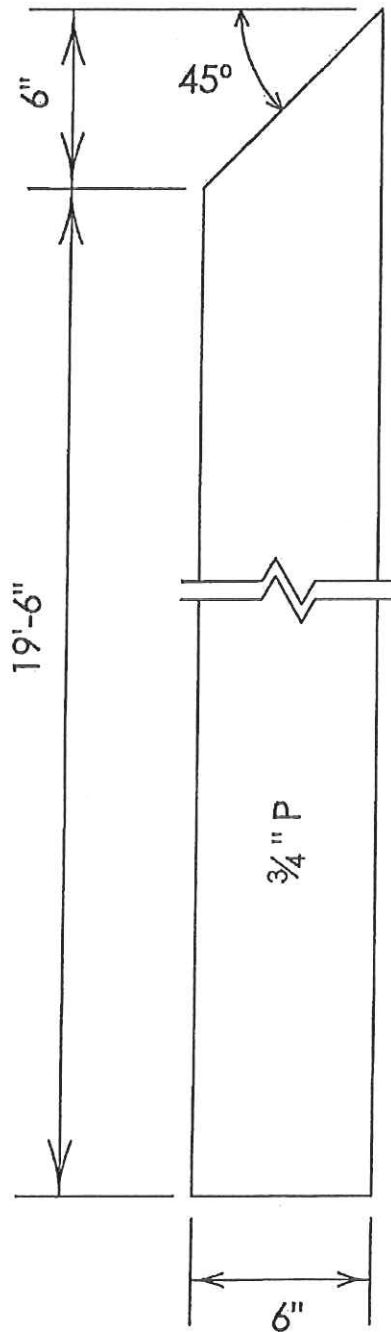

GALVANIZED 3/4" P
4 Required

WV DEPT. OF TRANSPORTATION - DIVISION OF HIGHWAYS
DISTRICT 8, P.O. BOX 1516
ELKINS, WV 26241

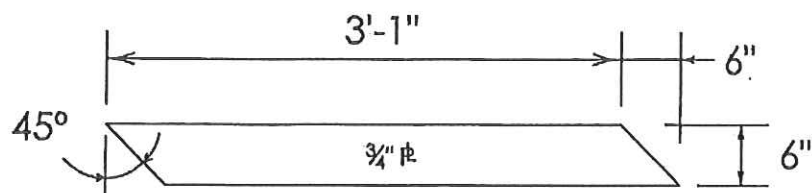

GALVANIZED $\frac{3}{4}$ " PLATE - MARK P2
(9 Required)

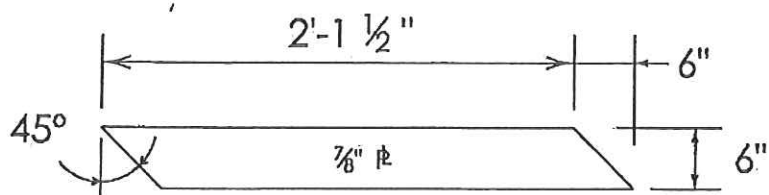

GALVANIZED $\frac{7}{8}$ " PLATE - MARK P1
(9 Required)

RPO NO. 08130144
SKETCH #8