





State of West Virginia  
 Department of Administration  
 Purchasing Division  
 2019 Washington Street East  
 Post Office Box 50130  
 Charleston, WV 25305-0130

# Request for Quotation

RFQ NUMBER  
**PRI11561**

PAGE  
**2**

ADDRESS CORRESPONDENCE TO ATTENTION OF:  
**TARA LYLE**  
**304-558-2544**

VENDOR

RFQ COPY  
 TYPE NAME/ADDRESS HERE  
**Matheny Motors**  
**4125 1st Avenue**  
**Nitro WV 25143**

SHIP TO

**WV PRISON INDUSTRIES**  
  
**617 LEON SULLIVAN WAY**  
**CHARLESTON, WV**  
**25301**                      **304-558-2945**

DATE PRINTED <b>01/09/2012</b>	TERMS OF SALE	SHIP VIA	F.O.B.	FREIGHT TERMS
BID OPENING DATE: <b>02/16/2012</b>		BID OPENING TIME <b>01:30PM</b>		

LINE	QUANTITY	UOP	CAT. NO.	ITEM NUMBER	UNIT PRICE	AMOUNT
<p>TO THE SPECIFICATIONS OF THE BID AND CONTRACT HEREIN.</p> <p><b>BANKRUPTCY:</b> IN THE EVENT THE VENDOR/CONTRACTOR FILES FOR BANKRUPTCY PROTECTION, THE STATE MAY DEEM THE CONTRACT NULL AND VOID, AND TERMINATE SUCH CONTRACT WITHOUT FURTHER ORDER.</p> <p>THE MODEL/BRAND/SPECIFICATIONS NAMED HEREIN ESTABLISH THE ACCEPTABLE LEVEL OF QUALITY ONLY AND ARE NOT INTENDED TO REFLECT A PREFERENCE OR FAVOR ANY PARTICULAR BRAND OR VENDOR. VENDORS WHO ARE BIDDING ALTERNATES SHOULD SO STATE AND INCLUDE PERTINENT LITERATURE AND SPECIFICATIONS. FAILURE TO PROVIDE INFORMATION FOR ANY ALTERNATES MAY BE GROUNDS FOR REJECTION OF THE BID. THE STATE RESERVES THE RIGHT TO WAIVE MINOR IRREGULARITIES IN BIDS OR SPECIFICATIONS IN ACCORDANCE WITH SECTION 148-1-4(F) OF THE WEST VIRGINIA LEGISLATIVE RULES AND REGULATIONS.</p> <p>ANY INDIVIDUAL SIGNING THIS BID IS CERTIFYING THAT: (1) HE OR SHE IS AUTHORIZED BY THE BIDDER TO EXECUTE THE BID OR ANY DOCUMENTS RELATED THERE TO ON BEHALF OF THE BIDDER, (2) THAT HE OR SHE IS AUTHORIZED TO BIND THE BIDDER IN A CONTRACTUAL RELATIONSHIP, AND (3) THAT THE BIDDER HAS PROPERLY REGISTERED WITH ANY STATE AGENCIES THAT MAY REQUIRE REGISTRATION.</p> <p style="text-align: center;">VENDOR PREFERENCE CERTIFICATE</p> <p>THIS TEAM EXHIBIT HAS BEEN REPLACED BY THE ONLINE VERSION WHICH IS AVAILABLE HERE:  <a href="http://www.state.wv.us/admin/purchase/vrc/venpref.pdf">HTTP://WWW.STATE.WV.US/ADMIN/PURCHASE/VRC/VENPREF.PDF</a></p> <p style="text-align: center;">NOTICE</p>						

SEE REVERSE SIDE FOR TERMS AND CONDITIONS						
SIGNATURE <i>Jackie A. C...</i>	TELEPHONE <b>304-769-5860</b>		DATE <b>2/15/2012</b>			
TITLE <b>Sales Consultant</b>	FEIN <b>55-032-0770</b>		ADDRESS CHANGES TO BE NOTED ABOVE			

WHEN RESPONDING TO RFQ, INSERT NAME AND ADDRESS IN SPACE ABOVE LABELED 'VENDOR'

## GENERAL TERMS & CONDITIONS REQUEST FOR QUOTATION (RFQ) AND REQUEST FOR PROPOSAL (RFP)

1. Awards will be made in the best interest of the State of West Virginia.
  2. The State may accept or reject in part, or in whole, any bid.
  3. Prior to any award, the apparent successful vendor must be properly registered with the Purchasing Division and have paid the required \$125 fee.
  4. All services performed or goods delivered under State Purchase Order/Contracts are to be continued for the term of the Purchase Order/Contracts, contingent upon funds being appropriated by the Legislature or otherwise being made available. In the event funds are not appropriated or otherwise available for these services or goods this Purchase Order/Contract becomes void and of no effect after June 30.
  5. Payment may only be made after the delivery and acceptance of goods or services.
  6. Interest may be paid for late payment in accordance with the *West Virginia Code*.
  7. Vendor preference will be granted upon written request in accordance with the *West Virginia Code*.
  8. The State of West Virginia is exempt from federal and state taxes and will not pay or reimburse such taxes.
  9. The Director of Purchasing may cancel any Purchase Order/Contract upon 30 days written notice to the seller.
  10. The laws of the State of West Virginia and the *Legislative Rules* of the Purchasing Division shall govern the purchasing process.
  11. Any reference to automatic renewal is hereby deleted. The Contract may be renewed only upon mutual written agreement of the parties.
  12. **BANKRUPTCY:** In the event the vendor/contractor files for bankruptcy protection, the State may deem this contract null and void, and terminate such contract without further order.
  13. **HIPAA BUSINESS ASSOCIATE ADDENDUM:** The West Virginia State Government HIPAA Business Associate Addendum (BAA), approved by the Attorney General, is available online at [www.state.wv.us/admin/purchase/vrc/hipaa.html](http://www.state.wv.us/admin/purchase/vrc/hipaa.html) and is hereby made part of the agreement provided that the Agency meets the definition of a Cover Entity (45 CFR §160.103) and will be disclosing Protected Health Information (45 CFR §160.103) to the vendor.
  14. **CONFIDENTIALITY:** The vendor agrees that he or she will not disclose to anyone, directly or indirectly, any such personally identifiable information or other confidential information gained from the agency, unless the individual who is the subject of the information consents to the disclosure in writing or the disclosure is made pursuant to the agency's policies, procedures, and rules. Vendor further agrees to comply with the Confidentiality Policies and Information Security Accountability Requirements, set forth in <http://www.state.wv.us/admin/purchase/privacy/noticeConfidentiality.pdf>.
  15. **LICENSING:** Vendors must be licensed and in good standing in accordance with any and all state and local laws and requirements by any state or local agency of West Virginia, including, but not limited to, the West Virginia Secretary of State's Office, the West Virginia Tax Department, and the West Virginia Insurance Commission. The vendor must provide all necessary releases to obtain information to enable the director or spending unit to verify that the vendor is licensed and in good standing with the above entities.
  16. **ANTITRUST:** In submitting a bid to any agency for the State of West Virginia, the bidder offers and agrees that if the bid is accepted the bidder will convey, sell, assign or transfer to the State of West Virginia all rights, title and interest in and to all causes of action it may now or hereafter acquire under the antitrust laws of the United States and the State of West Virginia for price fixing and/or unreasonable restraints of trade relating to the particular commodities or services purchased or acquired by the State of West Virginia. Such assignment shall be made and become effective at the time the purchasing agency tenders the initial payment to the bidder.
- I certify that this bid is made without prior understanding, agreement, or connection with any corporation, firm, limited liability company, partnership, or person or entity submitting a bid for the same material, supplies, equipment or services and is in all respects fair and without collusion or fraud. I further certify that I am authorized to sign the certification on behalf of the bidder or this bid.

### INSTRUCTIONS TO BIDDERS

1. Use the quotation forms provided by the Purchasing Division. Complete all sections of the quotation form.
2. Items offered must be in compliance with the specifications. Any deviation from the specifications must be clearly indicated by the bidder. Alternates offered by the bidder as **EQUAL** to the specifications must be clearly defined. A bidder offering an alternate should attach complete specifications and literature to the bid. The Purchasing Division may waive minor deviations to specifications.
3. Unit prices shall prevail in case of discrepancy. All quotations are considered F.O.B. destination unless alternate shipping terms are clearly identified in the quotation.
4. All quotations must be delivered by the bidder to the office listed below prior to the date and time of the bid opening. Failure of the bidder to deliver the quotations on time will result in bid disqualifications: Department of Administration, Purchasing Division, 2019 Washington Street East, P.O. Box 50130, Charleston, WV 25305-0130
5. Communication during the solicitation, bid, evaluation or award periods, except through the Purchasing Division, is strictly prohibited (W.Va. C.S.R. §148-1-6.6).



State of West Virginia  
 Department of Administration  
 Purchasing Division  
 2019 Washington Street East  
 Post Office Box 50130  
 Charleston, WV 25305-0130

# Request for Quotation

RFQ NUMBER  
**PRI11561**

PAGE  
**1**

ADDRESS CORRESPONDENCE TO ATTENTION OF:  
**TARA LYLE**  
**304-558-2544**

VENDOR

RFQ COPY  
 TYPE NAME/ADDRESS HERE  
**Matheny Motors**  
**4125 1st Avenue**  
**Nitro WV 25143**

SHIP TO

**WV PRISON INDUSTRIES**  
**617 LEON SULLIVAN WAY**  
**CHARLESTON, WV**  
**25301 304-558-2945**

DATE PRINTED <b>01/09/2012</b>	TERMS OF SALE	SHIP VIA	F.O.B.	FREIGHT TERMS
-----------------------------------	---------------	----------	--------	---------------

BID OPENING DATE: **02/16/2012** BID OPENING TIME **01:30PM**

LINE	QUANTITY	UOP	CAT. NO.	ITEM NUMBER	UNIT PRICE	AMOUNT
1001	1	EA		070-53	\$79,980.00	\$79,980.00
<p><b>DELIVERY TRUCK</b></p> <p>THE WEST VIRGINIA PURCHASING DIVISION FOR THE AGENCY, WEST VIRGINIA CORRECTIONAL INDUSTRIES, IS SOLICITING BIDS FOR ONE (1) 2011 OR NEWER DELIVERY TRUCK, PER THE ATTACHED SPECIFICATIONS.</p> <p>INQUIRIES:</p> <p>WRITTEN QUESTIONS WILL BE ACCEPTED UNTIL CLOSE OF BUSINESS ON 01/31/2012. QUESTIONS MAY BE SENT VIA USPS, FAX, COURIER OR E-MAIL. IN ORDER TO ASSURE NO VENDOR RECEIVES AN UNFAIR ADVANTAGE, NO SUBSTANTIVE QUESTIONS WILL BE ANSWERED ORALLY. IF POSSIBLE, E-MAIL QUESTIONS ARE PREFERRED. ADDRESS INQUIRIES TO:</p> <p>TARA LYLE          DEPARTMENT OF ADMINISTRATION          PURCHASING DIVISION          2019 WASHINGTON STREET, EAST          CHARLESTON, WV 25305</p> <p>FAX: 304-558-4115          EMAIL: TARA.L.LYLE@WV.GOV</p> <p>CANCELLATION: THE DIRECTOR OF PURCHASING RESERVES THE RIGHT TO CANCEL THIS CONTRACT IMMEDIATELY UPON WRITTEN NOTICE TO THE VENDOR IF THE COMMODITIES AND/OR SERVICES SUPPLIED ARE OF AN INFERIOR QUALITY OR DO NOT CONFORM</p>						

RECEIVED  
 FEB 16 A 8:00  
 PURCHASING DIVISION  
 STATE OF WV

SEE REVERSE SIDE FOR TERMS AND CONDITIONS

SIGNATURE <i>Tara Lyle</i>	TELEPHONE <b>304-769-5860</b>	DATE <b>2/15/2012</b>
TITLE <b>Sales Consultant</b>	FEIN <b>55-032-0770</b>	ADDRESS CHANGES TO BE NOTED ABOVE

WHEN RESPONDING TO RFQ. INSERT NAME AND ADDRESS IN SPACE ABOVE LABEL 'VENDOR'



State of West Virginia  
 Department of Administration  
 Purchasing Division  
 2019 Washington Street East  
 Post Office Box 50130  
 Charleston, WV 25305-0130

# Request for Quotation

RFQ NUMBER  
**PRI11561**

PAGE  
**1**

ADDRESS CORRESPONDENCE TO ATTENTION OF:  
**TARA LYLE**  
**304-558-2544**

VENDOR

RFQ COPY  
 TYPE NAME/ADDRESS HERE  
**Matheny Motors**  
**4125 1st Avenue**  
**Nitro WV 25143**

SHIP TO

**WV PRISON INDUSTRIES**  
**617 LEON SULLIVAN WAY**  
**CHARLESTON, WV**  
**25301**      **304-558-2945**

DATE PRINTED	TERMS OF SALE	SHIP VIA	F.O.B.	FREIGHT TERMS
01/31/2012				

BID OPENING DATE: **02/16/2012**      BID OPENING TIME **01:30PM**

LINE	QUANTITY	UOP	CAT. NO.	ITEM NUMBER	UNIT PRICE	AMOUNT
ADDENDUM NO. 1						
1. QUESTIONS AND ANSWERS ARE ATTACHED.						
2. ADDENDUM ACKNOWLEDGEMENT IS ATTACHED. THIS DOCUMENT SHOULD BE SIGNED AND RETURNED WITH YOUR BID. FAILURE TO SIGN AND RETURN MAY RESULT IN DISQUALIFICATION OF YOUR BID.						
END OF ADDENDUM NO. 1						
0001	1	EA		070-53	\$79,980.00	\$79,980.00
						\$79,980.00
***** THIS IS THE END OF RFQ PRI11561 ***** TOTAL:						

SEE REVERSE SIDE FOR TERMS AND CONDITIONS

SIGNATURE *James A. ...*      TELEPHONE **304-769-5860**      DATE **2/15/2012**

TITLE **Sales Consultant**      FEIN **55-032-0770**      ADDRESS CHANGES TO BE NOTED ABOVE

WHEN RESPONDING TO RFQ, INSERT NAME AND ADDRESS IN SPACE ABOVE LABELLED 'VENDOR'

## GENERAL TERMS & CONDITIONS REQUEST FOR QUOTATION (RFQ) AND REQUEST FOR PROPOSAL (RFP)

1. Awards will be made in the best interest of the State of West Virginia.
  2. The State may accept or reject in part, or in whole, any bid.
  3. Prior to any award, the apparent successful vendor must be properly registered with the Purchasing Division and have paid the required \$125 fee.
  4. All services performed or goods delivered under State Purchase Order/Contracts are to be continued for the term of the Purchase Order/Contracts, contingent upon funds being appropriated by the Legislature or otherwise being made available. In the event funds are not appropriated or otherwise available for these services or goods this Purchase Order/Contract becomes void and of no effect after June 30.
  5. Payment may only be made after the delivery and acceptance of goods or services.
  6. Interest may be paid for late payment in accordance with the *West Virginia Code*.
  7. Vendor preference will be granted upon written request in accordance with the *West Virginia Code*.
  8. The State of West Virginia is exempt from federal and state taxes and will not pay or reimburse such taxes.
  9. The Director of Purchasing may cancel any Purchase Order/Contract upon 30 days written notice to the seller.
  10. The laws of the State of West Virginia and the *Legislative Rules* of the Purchasing Division shall govern the purchasing process.
  11. Any reference to automatic renewal is hereby deleted. The Contract may be renewed only upon mutual written agreement of the parties.
  12. **BANKRUPTCY:** In the event the vendor/contractor files for bankruptcy protection, the State may deem this contract null and void, and terminate such contract without further order.
  13. **HIPAA BUSINESS ASSOCIATE ADDENDUM:** The West Virginia State Government HIPAA Business Associate Addendum (BAA), approved by the Attorney General, is available online at [www.state.wv.us/admin/purchase/vrc/hipaa.html](http://www.state.wv.us/admin/purchase/vrc/hipaa.html) and is hereby made part of the agreement provided that the Agency meets the definition of a Cover Entity (45 CFR §160.103) and will be disclosing Protected Health Information (45 CFR §160.103) to the vendor.
  14. **CONFIDENTIALITY:** The vendor agrees that he or she will not disclose to anyone, directly or indirectly, any such personally identifiable information or other confidential information gained from the agency, unless the individual who is the subject of the information consents to the disclosure in writing or the disclosure is made pursuant to the agency's policies, procedures, and rules. Vendor further agrees to comply with the Confidentiality Policies and Information Security Accountability Requirements, set forth in <http://www.state.wv.us/admin/purchase/privacy/noticeConfidentiality.pdf>.
  15. **LICENSING:** Vendors must be licensed and in good standing in accordance with any and all state and local laws and requirements by any state or local agency of West Virginia, including, but not limited to, the West Virginia Secretary of State's Office, the West Virginia Tax Department, and the West Virginia Insurance Commission. The vendor must provide all necessary releases to obtain information to enable the director or spending unit to verify that the vendor is licensed and in good standing with the above entities.
  16. **ANTITRUST:** In submitting a bid to any agency for the State of West Virginia, the bidder offers and agrees that if the bid is accepted the bidder will convey, sell, assign or transfer to the State of West Virginia all rights, title and interest in and to all causes of action it may now or hereafter acquire under the antitrust laws of the United States and the State of West Virginia for price fixing and/or unreasonable restraints of trade relating to the particular commodities or services purchased or acquired by the State of West Virginia. Such assignment shall be made and become effective at the time the purchasing agency tenders the initial payment to the bidder.
- I certify that this bid is made without prior understanding, agreement, or connection with any corporation, firm, limited liability company, partnership, or person or entity submitting a bid for the same material, supplies, equipment or services and is in all respects fair and without collusion or fraud. I further certify that I am authorized to sign the certification on behalf of the bidder or this bid.

### INSTRUCTIONS TO BIDDERS

1. Use the quotation forms provided by the Purchasing Division. Complete all sections of the quotation form.
2. Items offered must be in compliance with the specifications. Any deviation from the specifications must be clearly indicated by the bidder. Alternates offered by the bidder as EQUAL to the specifications must be clearly defined. A bidder offering an alternate should attach complete specifications and literature to the bid. The Purchasing Division may waive minor deviations to specifications.
3. Unit prices shall prevail in case of discrepancy. All quotations are considered F.O.B. destination unless alternate shipping terms are clearly identified in the quotation.
4. All quotations must be delivered by the bidder to the office listed below prior to the date and time of the bid opening. Failure of the bidder to deliver the quotations on time will result in bid disqualifications: Department of Administration, Purchasing Division, 2019 Washington Street East, P.O. Box 50130, Charleston, WV 25305-0130
5. Communication during the solicitation, bid, evaluation or award periods, except through the Purchasing Division, is strictly prohibited (W.Va. C.S.R. §148-1-6.6).

PRI11561  
Addendum # 1

QUESTIONS:

Q1: Axle Ratio to be 3.90:1; statement should be corrected to reflect the top miles per hour that you would like the unit to run. Ratios for each engine vary by this selection and maximum engine RPM's assigned to that engine. Thus, road speed will dictate ratio.

A1: 70 miles per hour.

Q2: Wheelbase no less than 260"; Cab to axle dimensions are normally utilized to best meet the body being installed; 24 foot bodies normally require something in the 186" CA range. Wheelbases vary from manufacturer to manufacturer. But the correct CA will be in this range.

A2: 186" CA range is acceptable.

Q3: Dual fuel tanks, minimum 100 gal. total; We suggest adding the verbiage "Aluminum" to this specification. Steel fuel tanks do not weather well in our environment (rust and corrosion) and new low sulphur fuels also take a toll on the inside of the steel tanks over time.

A3: Change the fuel tank specification from steel to aluminum.

Q4: Dual ac/dc fuel tank heaters with manual switch to change from truck power to 110 ac power when plugged in via power cord; we suggest using "Heated Fuel Water Separator" in lieu of the ac/dc fuel tank heater. Winter environment in West Virginia does not require such radical fuel heaters and the change can save the division money on the purchase.

A4: Agency will not change this specification. Our trucks travel the entire state and in the past we have had freezing issues in the Huttonsville, Martinsburg areas as well as other areas of the State. We must have the ac/dc fuel tank heaters.

\*\*\*\*\*

The bid opening remains 2/16/2012 at 1:30 pm.

No additional questions will be accepted on this RFQ.

\*\*\*\*\*

EXHIBIT 10

PRI11561

REQUISITION NO.: .....

ADDENDUM ACKNOWLEDGEMENT

I HEREBY ACKNOWLEDGE RECEIPT OF THE FOLLOWING CHECKED  
ADDENDUM(S) AND HAVE MADE THE NECESSARY REVISIONS TO MY  
PROPOSAL, PLANS AND/OR SPECIFICATION, ETC.

ADDENDUM NO.'S:

NO. 1 ..... X

NO. 2 .....

NO. 3 .....

NO. 4 .....

NO. 5 .....

I UNDERSTAND THAT FAILURE TO CONFIRM THE RECEIPT OF THE  
ADDENDUM(S) MAY BE CAUSE FOR REJECTION OF BIDS. VENDOR  
MUST CLEARLY UNDERSTAND THAT ANY VERBAL  
REPRESENTATION MADE OR ASSUMED TO BE MADE DURING ANY  
ORAL DISCUSSION HELD BETWEEN VENDOR'S REPRESENTATIVES  
AND ANY STATE PERSONNEL IS NOT BINDING. ONLY THE  
INFORMATION ISSUED IN WRITING AND ADDED TO THE  
SPECIFICATIONS BY AN OFFICIAL ADDENDUM IS BINDING.

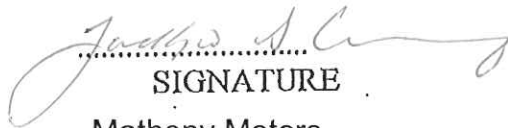
  
.....  
SIGNATURE

Matheny Motors

.....  
COMPANY

2/15/2012

.....  
DATE



**PRI11561****2011 or Newer Delivery Truck**

- GVWR 26,000, minimum
- Diesel engine shall be a minimum of 230 hp.
- Exhaust break w/driver controls
- AM/FM radio
- Air conditioned cab
- Transmission to be Allison 2500RDS or equal
- 6-speed automatic transmission
- Front tires 11r22.5g rated 12,350 lbs. Premium highway tread, minimum
- Rear tires 11r22.5g rated 23,000 lbs. Highway traction, minimum
- Axle ratio 3.90:1 or equal
- Wheelbase no less than 260"
- Nose cone on top of cab
- Dual fuel tanks, minimum 100 gallon total
- Dual ac/dc fuel tank heaters with manual switch to change from truck power to 110 ac power when plugged in via power cord
- Air brake system
- Rear dust shields
- Heated side mirrors
- Truck and body shall be painted white
- Driver seat shall be air suspension, high
- Passenger seat shall be two-man vinyl
- Frame mounted tool box 18"x18"x36", minimum
- On-spot chains mounted
- 24' dry freight van body
- Plywood lined 3/8" full, minimum
- Inside height 96", minimum
- Roll up rear door
- 1-1/8" hardwood floor, minimum
- Threshold steel diamond plate 1/8" x 23"
- Scuff side galvanized steel
- Translucent roof
- Two dome lights
- Two rows e-track each side
- 3300 lb capacity tuc-a-way lift gate with 80" x 48" aluminum platform or equal
- Aluminum body sides
- Fork lift package

- 1/2" plywood liner front, minimum
- Triangle kit & 5# fire extinguishers

**Warranty:**

All bidders must provide a copy of the manufacturer's warranty

**Delivery:**

Delivery costs shall be included with your bid. The truck shall be delivered to the agency with 90 days of award of this contract.

**Award:**

The contract will be awarded to one vendor with the lowest grand total meeting all of the specifications with the most complete bid.

PRI11561 - Bid Form

Bid Form

Item #	Description	Quantity	Unit Price	Extended Amount
1	2011 or newer delivery truck per the specifications	1	\$ 79,980.00	\$ 79,980.00
	Failure to use this form may result in disqualification		GRAND TOTAL:	\$ 79,980.00
Bidder / Vendor Information:				
Vendor Name: Matheny Motors				
Contact Name: Jack Cummings				
Address: 4125 1st Avenue				
Nitro WV 25143				
Phone No.: 304-769-5860				
Fax No.: 304-769-5865				
Email Address: jcummings@mathenymotors.com				
Authorized Signature: 				



RFQ No. PRI11561

STATE OF WEST VIRGINIA  
Purchasing Division

**PURCHASING AFFIDAVIT**

West Virginia Code §5A-3-10a states: No contract or renewal of any contract may be awarded by the state or any of its political subdivisions to any vendor or prospective vendor when the vendor or prospective vendor or a related party to the vendor or prospective vendor is a debtor and the debt owned is an amount greater than one thousand dollars in the aggregate

**DEFINITIONS:**

"Debt" means any assessment, premium, penalty, fine, tax or other amount of money owed to the state or any of its political subdivisions because of a judgment, fine, permit violation, license assessment, defaulted workers' compensation premium, penalty or other assessment presently delinquent or due and required to be paid to the state or any of its political subdivisions, including any interest or additional penalties accrued thereon.

"Debtor" means any individual, corporation, partnership, association, Limited Liability Company or any other form or business association owing a debt to the state or any of its political subdivisions. "Political subdivision" means any county commission; municipality; county board of education; any instrumentality established by a county or municipality; any separate corporation or instrumentality established by one or more counties or municipalities, as permitted by law; or any public body charged by law with the performance of a government function or whose jurisdiction is coextensive with one or more counties or municipalities. "Related party" means a party, whether an individual, corporation, partnership, association, limited liability company or any other form or business association or other entity whatsoever, related to any vendor by blood, marriage, ownership or contract through which the party has a relationship of ownership or other interest with the vendor so that the party will actually or by effect receive or control a portion of the benefit, profit or other consideration from performance of a vendor contract with the party receiving an amount that meets or exceed five percent of the total contract amount.

**EXCEPTION:** The prohibition of this section does not apply where a vendor has contested any tax administered pursuant to chapter eleven of this code, workers' compensation premium, permit fee or environmental fee or assessment and the matter has not become final or where the vendor has entered into a payment plan or agreement and the vendor is not in default of any of the provisions of such plan or agreement.

Under penalty of law for false swearing (*West Virginia Code* §61-5-3), it is hereby certified that the vendor affirms and acknowledges the information in this affidavit and is in compliance with the requirements as stated.

**WITNESS THE FOLLOWING SIGNATURE**

Vendor's Name: Matheny Motors

Authorized Signature: *Jackie D. C...* Date: 2/15/2012

State of WV

County of Putnam, to-wit:

Taken, subscribed, and sworn to before me this 15<sup>th</sup> day of FEBRUARY, 2012.

My Commission expires NOV. 9, 2021.

AFFIX SEAL HERE

NOTARY PUBLIC *Matt Scantlin*

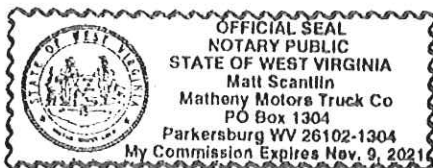



# State of West Virginia VENDOR PREFERENCE CERTIFICATE

Certification and application\* is hereby made for Preference in accordance with *West Virginia Code*, §5A-3-37. (Does not apply to construction contracts). *West Virginia Code*, §5A-3-37, provides an opportunity for qualifying vendors to request (at the time of bid) preference for their residency status. Such preference is an evaluation method only and will be applied only to the cost bid in accordance with the *West Virginia Code*. This certificate for application is to be used to request such preference. The Purchasing Division will make the determination of the Resident Vendor Preference, if applicable.

- 1. **Application is made for 2.5% resident vendor preference for the reason checked:**  
 \_\_\_\_\_ Bidder is an individual resident vendor and has resided continuously in West Virginia for four (4) years immediately preceding the date of this certification; **or**,  
 \_\_\_\_\_ Bidder is a partnership, association or corporation resident vendor and has maintained its headquarters or principal place of business continuously in West Virginia for four (4) years immediately preceding the date of this certification; **or** 80% of the ownership interest of Bidder is held by another individual, partnership, association or corporation resident vendor who has maintained its headquarters or principal place of business continuously in West Virginia for four (4) years immediately preceding the date of this certification; **or**,  
 \_\_\_\_\_ Bidder is a nonresident vendor which has an affiliate or subsidiary which employs a minimum of one hundred state residents and which has maintained its headquarters or principal place of business within West Virginia continuously for the four (4) years immediately preceding the date of this certification; **or**,
- 2. **Application is made for 2.5% resident vendor preference for the reason checked:**  
 \_\_\_\_\_ Bidder is a resident vendor who certifies that, during the life of the contract, on average at least 75% of the employees working on the project being bid are residents of West Virginia who have resided in the state continuously for the two years immediately preceding submission of this bid; **or**,
- 3. **Application is made for 2.5% resident vendor preference for the reason checked:**  
 \_\_\_\_\_ Bidder is a nonresident vendor employing a minimum of one hundred state residents or is a nonresident vendor with an affiliate or subsidiary which maintains its headquarters or principal place of business within West Virginia employing a minimum of one hundred state residents who certifies that, during the life of the contract, on average at least 75% of the employees or Bidder's affiliate's or subsidiary's employees are residents of West Virginia who have resided in the state continuously for the two years immediately preceding submission of this bid; **or**,
- 4.  **Application is made for 5% resident vendor preference for the reason checked:**  
 \_\_\_\_\_ Bidder meets either the requirement of both subdivisions (1) and (2) or subdivision (1) and (3) as stated above; **or**,
- 5. **Application is made for 3.5% resident vendor preference who is a veteran for the reason checked:**  
 \_\_\_\_\_ Bidder is an individual resident vendor who is a veteran of the United States armed forces, the reserves or the National Guard and has resided in West Virginia continuously for the four years immediately preceding the date on which the bid is submitted; **or**,
- 6. **Application is made for 3.5% resident vendor preference who is a veteran for the reason checked:**  
 \_\_\_\_\_ Bidder is a resident vendor who is a veteran of the United States armed forces, the reserves or the National Guard, if, for purposes of producing or distributing the commodities or completing the project which is the subject of the vendor's bid and continuously over the entire term of the project, on average at least seventy-five percent of the vendor's employees are residents of West Virginia who have resided in the state continuously for the two immediately preceding years.

Bidder understands if the Secretary of Revenue determines that a Bidder receiving preference has failed to continue to meet the requirements for such preference, the Secretary may order the Director of Purchasing to: (a) reject the bid; or (b) assess a penalty against such Bidder in an amount not to exceed 5% of the bid amount and that such penalty will be paid to the contracting agency or deducted from any unpaid balance on the contract or purchase order.

By submission of this certificate, Bidder agrees to disclose any reasonably requested information to the Purchasing Division and authorizes the Department of Revenue to disclose to the Director of Purchasing appropriate information verifying that Bidder has paid the required business taxes, provided that such information does not contain the amounts of taxes paid nor any other information deemed by the Tax Commissioner to be confidential.

Under penalty of law for false swearing (*West Virginia Code*, §61-5-3), Bidder hereby certifies that this certificate is true and accurate in all respects; and that if a contract is issued to Bidder and if anything contained within this certificate changes during the term of the contract, Bidder will notify the Purchasing Division in writing immediately.

Bidder: Matheny Motors  
Date: 2/15/2012

Signed:   
Title: Sales Consultant

\*Check any combination of preference consideration(s) indicated above, which you are entitled to receive.







**MATHENY MOTOR TRUCK CO.**

Established 1922  
3rd & Ann Streets • P.O. Box 1304  
Parkersburg, WV 26102  
(304) 485-4418 • (304) 485-2577 fax  
[www.mathenymotors.com](http://www.mathenymotors.com)

February 15, 2012

Tara Lyle  
Department of Administration  
Purchasing Division  
2019 Washington St East  
Charleston, WV 25305

RE: PRI11561

Ms. Lyle,

Thank you for this opportunity to submit a proposal on your vehicle needs. Please find attached the warranty information, standards list, and invoice for a 2013 Freightliner. This vehicle meets or exceeds your specs with the following exceptions:

Delivery within 120 days.

Please also find attached a copy of the box specs, warranty information and lift gate information.

A handwritten signature in cursive script, appearing to read "Jack Cummings".

Jack Cummings (Commercial Sales Consultant)  
Matheny Commercial Trucks  
4125 1<sup>st</sup> Avenue  
Nitro, WV 25143  
Office 304-769-5860  
Fax 304-769-5865  
Cell 304-539-3817  
[www.mathenymotors.com](http://www.mathenymotors.com)



Prepared for:  
 Tara Lyle  
 WV Prison Industries  
 617 Leon Sullivan Way  
 Charleston, WV 25301  
 Phone: 304-558-2544

Prepared by:  
 Jackie Cummings  
 MATHENY MOTOR TRUCK  
 COMPANY  
 50 Mtheny Lane  
 Mineral Springs, WV 26150  
 Phone: 3044854418

## S P E C I F I C A T I O N   P R O P O S A L

Data Code	Description	Weight Front	Weight Rear	Retail Price
<b>Price Level</b>				
PRL-03M	M2 PRL-03M (EFF:01/25/12)			STD
<b>Data Version</b>				
DRL-005	SPECPRO21 DATA RELEASE VER 005			N/C
<b>Vehicle Configuration</b>				
001-172	M2 106 CONVENTIONAL CHASSIS	5,205	3,055	\$86,600.00
004-213	2013 MODEL YEAR SPECIFIED			STD
002-004	SET BACK AXLE - TRUCK			STD
019-002	STRAIGHT TRUCK PROVISION			STD
003-001	LH PRIMARY STEERING LOCATION			STD
<b>General Service</b>				
AA1-002	TRUCK CONFIGURATION			STD
AA6-001	DOMICILED, USA 50 STATES (INCLUDING CALIFORNIA AND CARB OPT-IN STATES)			N/C
A85-002	PICKUP AND DELIVERY/SHORT HAUL SERVICE			STD
A84-1GM	GOVERNMENT BUSINESS SEGMENT			N/C
AA4-001	GENERAL FREIGHT COMMODITY			STD
AA5-002	TERRAIN/DUTY: 100% (ALL) OF THE TIME, IN TRANSIT, IS SPENT ON PAVED ROADS			STD
AB1-008	MAXIMUM 8% EXPECTED GRADE			STD
AB5-001	SMOOTH CONCRETE OR ASPHALT PAVEMENT - MOST SEVERE IN-TRANSIT (BETWEEN SITES) ROAD SURFACE			STD
995-091	MEDIUM TRUCK WARRANTY			STD
A66-99D	EXPECTED FRONT AXLE(S) LOAD : 8000.0 lbs			
A68-99D	EXPECTED REAR DRIVE AXLE(S) LOAD : 18000.0 lbs			
A63-99D	EXPECTED GROSS VEHICLE WEIGHT CAPACITY : 26000.0 lbs			





Prepared for:  
 Tara Lyle  
 WV Prison Industries  
 617 Leon Sullivan Way  
 Charleston, WV 25301  
 Phone: 304-558-2544

Prepared by:  
 Jackie Cummings  
 MATHENY MOTOR TRUCK  
 COMPANY  
 50 Mtheny Lane  
 Mineral Springs, WV 26150  
 Phone: 3044854418

Data Code	Description	Weight Front	Weight Rear	Retail Price
GVWR	RATED MAXIMUM VEHICLE CAPACITY - GVWR : 26000.0 lbs			N/C
<b>Truck Service</b>				
AA3-001	DRY VAN BODY			STD
AF7-99D	EXPECTED BODY/PAYLOAD CG HEIGHT ABOVE FRAME "XX" INCHES : 32.0 in			
<b>Engine</b>				
101-2GD	CUM ISB 6.7-240 240 HP @ 2300 RPM, 2600 GOV, 560 LB/FT @ 1600 RPM			\$1,954.00
<b>Electronic Parameters</b>				
79A-075	75 MPH ROAD SPEED LIMIT			STD
79B-000	CRUISE CONTROL SPEED LIMIT SAME AS ROAD SPEED LIMIT			N/C
79K-005	PTO MODE ENGINE RPM LIMIT - 900 RPM			N/C
79L-002	PTO MODE THROTTLE OVERRIDE - LIMIT TO 900 RPM			N/C
79M-001	PTO MODE BRAKE OVERRIDE - SERVICE BRAKE ONLY ENABLED			N/C
79P-004	PTO RPM WITH CRUISE SET SWITCH - 900 RPM			N/C
79Q-004	PTO RPM WITH CRUISE RESUME SWITCH - 900 RPM			N/C
79S-001	PTO MODE CANCEL VEHICLE SPEED - 5 MPH			N/C
79U-007	PTO GOVERNOR RAMP RATE - 250 RPM PER SECOND			N/C
80G-002	PTO MINIMUM RPM - 700			N/C
80J-002	REGEN INHIBITIT SPEED THRESHOLD - 5 MPH			N/C
<b>Engine Equipment</b>				
99C-010	2010 EPA/CARB EMISSION CERTIFICATION			STD
99D-009	2008 CARB EMISSION CERTIFICATION - CLEAN IDLE (INCLUDES 6X4 INCH LABEL ON LEFT SIDE OF HOOD)			\$106.00
105-001	ENGINE MOUNTED OIL CHECK AND FILL			STD
133-004	ONE PIECE VALVE COVER			STD
014-099	SIDE OF HOOD AIR INTAKE WITH FIREWALL MOUNTED DONALDSON AIR CLEANER			STD
124-1D7	DR 12V 160 AMP 28-SI QUADRAMOUNT PAD ALTERNATOR WITH REMOTE BATTERY VOLT SENSE			STD
292-1D8	(2) ALLIANCE MODEL 1131, GROUP 31, 12 VOLT MAINTENANCE FREE 1850 CCA THREADED STUD BATTERIES			STD
290-017	BATTERY BOX FRAME MOUNTED			STD





Prepared for:  
Tara Lyle  
WV Prison Industries  
617 Leon Sullivan Way  
Charleston, WV 25301  
Phone: 304-558-2544

Prepared by:  
Jackie Cummings  
MATHENY MOTOR TRUCK  
COMPANY  
50 Mtheny Lane  
Mineral Springs, WV 26150  
Phone: 3044854418

Data Code	Description	Weight Front	Weight Rear	Retail Price
282-001	SINGLE BATTERY BOX FRAME MOUNTED LH SIDE UNDER CAB			STD
291-017	WIRE GROUND RETURN FOR BATTERY CABLES WITH ADDITIONAL FRAME GROUND RETURN			STD
289-001	NON-POLISHED BATTERY BOX COVER			STD
293-058	POSITIVE LOAD DISCONNECT WITH CAB MOUNTED CONTROL SWITCH MOUNTED OUTBOARD DRIVER SEAT	8		\$318.00
107-032	CUMMINS 18.7 CFM AIR COMPRESSOR WITH INTERNAL SAFETY VALVE			N/C
108-002	STANDARD AIR COMPRESSOR GOVERNOR			N/C
131-013	AIR COMPRESSOR DISCHARGE LINE			N/C
152-041	ELECTRONIC ENGINE INTEGRAL SHUTDOWN PROTECTION SYSTEM			STD
128-076	CUMMINS EXHAUST BRAKE INTEGRAL WITH VARIABLE GEOMETRY TURBO WITH ON/OFF DASH SWITCH			\$67.00
016-1C3	RH OUTBOARD UNDER STEP MOUNTED HORIZONTAL AFTERTREATMENT SYSTEM ASSEMBLY WITH RH HORIZONTAL TAILPIPE			STD
28F-002	ENGINE AFTERTREATMENT DEVICE, AUTOMATIC OVER THE ROAD REGENERATION AND DASH MOUNTED REGENERATION REQUEST SWITCH			STD
239-001	STANDARD EXHAUST SYSTEM LENGTH			STD
237-052	RH STANDARD HORIZONTAL TAILPIPE			STD
23U-001	6 GALLON DIESEL EXHAUST FLUID TANK			STD
23Y-001	STANDARD DIESEL EXHAUST FLUID PUMP MOUNTING			STD
43X-002	LH MEDIUM DUTY STANDARD DIESEL EXHAUST FLUID TANK LOCATION			STD
43Y-001	STANDARD DIESEL EXHAUST FLUID TANK CAP			STD
273-035	HORTON HT650 FRONTAL AIR ON/OFF ENGINE FAN CLUTCH			N/C
276-001	AUTOMATIC FAN CONTROL WITHOUT DASH SWITCH, NON ENGINE MOUNTED			N/C
110-003	CUMMINS SPIN ON FUEL FILTER			STD
118-001	FULL FLOW OIL FILTER			STD
266-078	950 SQUARE INCH ALUMINUM RADIATOR			STD
103-036	ANTIFREEZE TO -34F, ETHYLENE GLYCOL PRE- CHARGED SCA HEAVY DUTY COOLANT			(\$94.00)
171-007	GATES BLUE STRIPE COOLANT HOSES OR EQUIVALENT			STD





Prepared for:  
Tara Lyle  
WV Prison Industries  
617 Leon Sullivan Way  
Charleston, WV 25301  
Phone: 304-558-2544

Prepared by:  
Jackie Cummings  
MATHENY MOTOR TRUCK  
COMPANY  
50 Mtheny Lane  
Mineral Springs, WV 26150  
Phone: 3044854418

Data Code	Description	Weight Front	Weight Rear	Retail Price
172-001	CONSTANT TENSION HOSE CLAMPS FOR COOLANT HOSES			STD
270-016	RADIATOR DRAIN VALVE			STD
168-002	LOWER RADIATOR GUARD			STD
360-998	NO FRONT ENGINE PTO			STD
138-010	PHILLIPS-TEMRO 750 WATT/115 VOLT BLOCK HEATER	4		\$151.00
140-053	BLACK PLASTIC ENGINE HEATER RECEPTACLE MOUNTED UNDER LH DOOR			N/C
134-001	ALUMINUM FLYWHEEL HOUSING			STD
132-004	ELECTRIC GRID AIR INTAKE WARMER			STD
155-057	DELCO 12V 29MT STARTER WITH INTEGRATED MAGNETIC SWITCH			STD
<b>Transmission</b>				
342-1MN	ALLISON 2500 RDS AUTOMATIC TRANSMISSION WITH PTO PROVISION			\$1,784.00
<b>Transmission Equipment</b>				
352-998	NO AUXILIARY TRANSMISSION			STD
343-1Y3	1XXX/2XXX TRANSMISSION PROGRAMMING, 6 SPEED, RDS, 6/3/2/1 SELECTOR (PACKAGE 354) WITH LBSS			N/C
362-1BU	CUSTOMER INSTALLED CHELSEA 230/231/236 SERIES PTO			N/C
363-001	PTO MOUNTING, LH SIDE OF MAIN TRANSMISSION			N/C
341-018	MAGNETIC PLUGS, ENGINE DRAIN, TRANSMISSION DRAIN, AXLE(S) FILL AND DRAIN			STD
345-072	DASH MOUNTED T-HANDLE CABLE SHIFT CONTROL WITHOUT PARK BRAKE POSITION			N/C
97G-002	TRANSMISSION PROGNOSTICS - DISABLED(N/A)			STD
370-015	WATER TO OIL TRANSMISSION COOLER, IN RADIATOR END TANK			STD
346-001	TRANSMISSION OIL CHECK AND FILL			STD
35T-001	SYNTHETIC TRANSMISSION FLUID (TES-295 COMPLIANT)			STD
<b>Front Axle and Equipment</b>				
400-1EW	DETROIT DA-F-8.0-3 8,000# FF1 71.5 KPI/3.74 DROP SINGLE FRONT AXLE	50		\$203.00
402-020	MERITOR 15X4 Q+ CAM FRONT BRAKES			N/C
403-002	NON-ASBESTOS FRONT BRAKE LINING			STD





Prepared for:  
 Tara Lyle  
 WV Prison Industries  
 617 Leon Sullivan Way  
 Charleston, WV 25301  
 Phone: 304-558-2544

Prepared by:  
 Jackie Cummings  
 MATHENY MOTOR TRUCK  
 COMPANY  
 50 Mtheny Lane  
 Mineral Springs, WV 26150  
 Phone: 3044854418

Data Code	Description	Weight Front	Weight Rear	Retail Price
419-023	CONMET CAST IRON FRONT BRAKE DRUMS			N/C
409-021	SKF SCOTSEAL PLUS XL FRONT OIL SEALS			N/C
408-001	VENTED FRONT HUB CAPS WITH WINDOW, CENTER AND SIDE PLUGS - OIL			STD
416-022	STANDARD SPINDLE NUTS FOR ALL AXLES			STD
405-002	MERITOR AUTOMATIC FRONT SLACK ADJUSTERS			N/C
536-050	TRW THP-60 POWER STEERING	10		N/C
539-003	POWER STEERING PUMP			STD
534-015	2 QUART SEE THROUGH POWER STEERING RESERVOIR			STD
40T-003	SYNTHETIC 50W FRONT AXLE LUBE			\$20.00
<b>Front Suspension</b>				
620-062	10,000# TAPERLEAF FRONT SUSPENSION	40		\$26.00
619-005	MAINTENANCE FREE RUBBER BUSHINGS - FRONT SUSPENSION			STD
410-001	FRONT SHOCK ABSORBERS			STD
<b>Rear Axle and Equipment</b>				
420-1M8	MS-19-14X 19,000# R-SERIES SINGLE REAR AXLE		140	\$390.00
421-529	5.29 REAR AXLE RATIO			N/C
424-001	IRON REAR AXLE CARRIER WITH STANDARD AXLE HOUSING			STD
386-073	MXL 17T MERITOR EXTENDED LUBE MAIN DRIVELINE WITH HALF ROUND YOKES	85	85	\$814.00
423-020	MERITOR 16.5X7 Q+ CAST SPIDER CAM REAR BRAKES, DOUBLE ANCHOR, FABRICATED SHOES			(\$93.00)
433-003	ABEX 931-162 (MERITOR R301) REAR BRAKE LINING			N/C
434-011	BRAKE CAMS AND CHAMBERS ON FORWARD SIDE OF DRIVE AXLE(S)			N/C
451-023	CONMET CAST IRON REAR BRAKE DRUMS			N/C
425-002	REAR BRAKE DUST SHIELDS		5	\$58.00
440-021	SKF SCOTSEAL PLUS XL REAR OIL SEALS			N/C
426-074	HALDEX GOLDSEAL LONGSTROKE 1-DRIVE AXLE SPRING PARKING CHAMBERS			N/C
428-002	MERITOR AUTOMATIC REAR SLACK ADJUSTERS			N/C
41T-002	SYNTHETIC 75W-90 REAR AXLE LUBE			\$107.00
<b>Rear Suspension</b>				



Prepared for:  
 Tara Lyle  
 WV Prison Industries  
 617 Leon Sullivan Way  
 Charleston, WV 25301  
 Phone: 304-558-2544

Prepared by:  
 Jackie Cummings  
 MATHENY MOTOR TRUCK  
 COMPANY  
 50 Mtheny Lane  
 Mineral Springs, WV 26150  
 Phone: 3044854418

Data Code	Description	Weight Front	Weight Rear	Retail Price
622-1MD	18,000# 52 INCH VARIABLE RATE MULTI-LEAF SPRING REAR SUSPENSION		70	\$73.00
621-001	SPRING SUSPENSION - NO AXLE SPACERS			STD
431-001	STANDARD U-BOLT PAD			STD
<b>Brake System</b>				
018-002	AIR BRAKE PACKAGE	80	140	\$1,162.00
490-100	WABCO 4S/4M ABS WITHOUT TRACTION CONTROL			N/C
871-001	REINFORCED NYLON, FABRIC BRAID AND WIRE BRAID CHASSIS AIR LINES			N/C
904-001	FIBER BRAID PARKING BRAKE HOSE			N/C
412-001	STANDARD BRAKE SYSTEM VALVES			N/C
46D-002	STANDARD AIR SYSTEM PRESSURE PROTECTION SYSTEM			N/C
413-002	STD U.S. FRONT BRAKE VALVE			N/C
432-003	RELAY VALVE WITH 5-8 PSI CRACK PRESSURE, NO REAR PROPORTIONING VALVE			N/C
480-083	WABCO SS-1200 PLUS AIR DRYER WITH INTEGRAL AIR GOVERNOR AND HEATER	20		\$324.00
479-015	AIR DRYER FRAME MOUNTED			N/C
460-001	STEEL AIR BRAKE RESERVOIRS			N/C
477-001	PULL CABLE ON WET TANK, PETCOCK DRAIN VALVES ON ALL OTHER AIR TANKS			N/C
<b>Trailer Connections</b>				
335-004	UPGRADED CHASSIS MULTIPLEXING UNIT			N/C
32A-002	UPGRADED BULKHEAD MULTIPLEXING UNIT			STD
<b>Wheelbase &amp; Frame</b>				
545-640	6400MM (252 INCH) WHEELBASE			N/C
546-093	11/32X3-1/2X10-3/16 INCH STEEL FRAME (8.73MMX258.8/0.344X10.19 INCH) 80KSI	590	110	\$978.00
552-030	1600MM (63 INCH) REAR FRAME OVERHANG			STD
55W-006	FRAME OVERHANG RANGE: 61 INCH TO 70 INCH	-10	40	N/C
AC8-99D	CALC'D BACK OF CAB TO REAR SUSP C/L (CA) : 186.45 in			
AE8-99D	CALCULATED EFFECTIVE BACK OF CAB TO REAR SUSPENSION C/L (CA) : 183.45 in			
AE4-99D	CALC'D FRAME LENGTH - OVERALL : 344.39			
AM6-99D	CALC'D SPACE AVAILABLE FOR DECKPLATE : 186.45 in			
FSS-0LH	FRAME SPACE LH SIDE : 128.71 in			N/C





Prepared for:  
Tara Lyle  
WV Prison Industries  
617 Leon Sullivan Way  
Charleston, WV 25301  
Phone: 304-558-2544

Prepared by:  
Jackie Cummings  
MATHENY MOTOR TRUCK  
COMPANY  
50 Mtheny Lane  
Mineral Springs, WV 26150  
Phone: 3044854418

Data Code	Description	Weight Front	Weight Rear	Retail Price
FSS-0RH	FRAME SPACE RH SIDE : 129.12 in			N/C
553-001	SQUARE END OF FRAME			STD
550-001	FRONT CLOSING CROSSMEMBER			STD
559-001	STANDARD WEIGHT ENGINE CROSSMEMBER			STD
562-001	STANDARD MIDSHIP #1 CROSSMEMBER(S)			STD
572-001	STANDARD REARMOST CROSSMEMBER			STD
565-001	STANDARD SUSPENSION CROSSMEMBER			STD
<b>Chassis Equipment</b>				
556-1AN	THREE-PIECE 14 INCH STEEL CENTER BUMPER WITH FLEXIBLE PLASTIC ENDS			STD
574-001	BUMPER MOUNTING FOR SINGLE LICENSE PLATE			STD
585-998	NO MUDFLAP BRACKETS			STD
590-998	NO REAR MUDFLAPS			STD
586-024	FENDER AND FRONT OF HOOD MOUNTED FRONT MUDFLAPS			STD
551-007	GRADE 8 THREADED HEX HEADED FRAME FASTENERS			STD
<b>Fuel Tanks</b>				
206-192	50 GALLON/189 LITER RECTANGULAR ALUMINUM FUEL TANK - RH	80	20	\$865.00
204-192	50 GALLON/189 LITER RECTANGULAR ALUMINUM FUEL TANK - LH	20		\$87.00
218-005	RECTANGULAR FUEL TANK(S)			STD
215-005	PLAIN ALUMINUM/PAINTED STEEL FUEL/HYDRAULIC TANK(S) WITH PAINTED BANDS			STD
212-008	FUEL TANK(S) AFT	70	70	\$599.00
664-001	PLAIN STEP FINISH			STD
205-001	FUEL TANK CAP(S)			STD
122-084	ALLIANCE FUEL FILTER/WATER SEPARATOR WITH PRIMER PUMP			STD
216-020	EQUIFLO INBOARD FUEL SYSTEM			STD
202-016	HIGH TEMPERATURE REINFORCED NYLON FUEL LINE			STD
<b>Tires</b>				
093-1T8	GOODYEAR G662 RSA FUEL MAX 11R22.5 14 PLY RADIAL FRONT TIRES (MATCH MARKED)	22		\$596.00
094-2B1	MICHELIN XZA3+ 11R22.5 14 PLY RADIAL REAR TIRES		24	\$2,500.00
<b>Hubs</b>				







Prepared for:  
Tara Lyle  
WV Prison Industries  
617 Leon Sullivan Way  
Charleston, WV 25301  
Phone: 304-558-2544

Prepared by:  
Jackie Cummings  
MATHENY MOTOR TRUCK  
COMPANY  
50 Mtheny Lane  
Mineral Springs, WV 26150  
Phone: 3044854418

Data Code	Description	Weight Front	Weight Rear	Retail Price
418-045	CONMET PRE-SET BEARING IRON FRONT HUBS			N/C
450-045	CONMET PRE-SET BEARING IRON REAR HUBS			N/C
<b>Wheels</b>				
502-717	ACCURIDE 50408 ACCU-LITE 22.5X8.25 10-HUB PILOT 2-HAND STEEL DISC FRONT WHEELS	-20		(\$28.00)
505-717	ACCURIDE 50408 ACCU-LITE 22.5X8.25 10-HUB PILOT 2-HAND STEEL DISC REAR WHEELS		-40	(\$56.00)
496-011	FRONT WHEEL MOUNTING NUTS			STD
497-011	REAR WHEEL MOUNTING NUTS			STD
<b>Cab Exterior</b>				
829-071	106 INCH BBC FLAT ROOF ALUMINUM CONVENTIONAL CAB			STD
650-008	AIR CAB MOUNTS			\$154.00
754-998	NO FENDER EXTENSION			STD
646-009	PAINTED PLASTIC GRILLE			STD
65X-001	ARGENT SILVER HOOD MOUNTED AIR INTAKE GRILLE			STD
644-004	FIBERGLASS HOOD			STD
727-1AF	SINGLE 14 INCH ROUND HADLEY AIR HORN UNDER LH DECK	4		\$135.00
726-001	SINGLE ELECTRIC HORN			STD
728-001	SINGLE HORN SHIELD			N/C
657-001	DOOR LOCKS AND IGNITION SWITCH KEYED THE SAME			STD
575-001	REAR LICENSE PLATE MOUNT END OF FRAME			STD
312-043	INTEGRAL HEADLIGHT/MARKER ASSEMBLY			STD
302-001	(5) AMBER MARKER LIGHTS			STD
311-001	DAYTIME RUNNING LIGHTS			\$23.00
294-001	INTEGRAL STOP/TAIL/BACKUP LIGHTS			STD
300-015	STANDARD FRONT TURN SIGNAL LAMPS			STD
744-1BG	DUAL WEST COAST MOLDED-IN COLOR HEATED MIRRORS			\$162.00
797-001	DOOR MOUNTED MIRRORS			STD
796-001	102 INCH EQUIPMENT WIDTH			STD
743-1AP	LH AND RH 8" MOLDED-IN COLOR CONVEX MIRRORS MOUNTED UNDER PRIMARY MIRRORS			N/C
729-001	STANDARD SIDE/REAR REFLECTORS			STD
768-043	63X14 INCH TINTED REAR WINDOW			STD
661-003	TINTED DOOR GLASS LH AND RH WITH TINTED NON-OPERATING WING WINDOWS			STD



Prepared for:  
Tara Lyle  
WV Prison Industries  
617 Leon Sullivan Way  
Charleston, WV 25301  
Phone: 304-558-2544

Prepared by:  
Jackie Cummings  
MATHENY MOTOR TRUCK  
COMPANY  
50 Mtheny Lane  
Mineral Springs, WV 26150  
Phone: 3044854418

Data Code	Description	Weight Front	Weight Rear	Retail Price
654-003	MANUAL DOOR WINDOW REGULATORS			STD
663-019	1-PIECE TINTED ROPED-IN WINDSHIELD			\$29.00
659-019	2 GALLON WINDSHIELD WASHER RESERVOIR WITHOUT FLUID LEVEL INDICATOR, FRAME MOUNTED			STD
<b>Cab Interior</b>				
707-1AM	OPAL GRAY CLOTH INTERIOR			STD
706-013	MOLDED PLASTIC DOOR PANEL			STD
708-013	MOLDED PLASTIC DOOR PANEL			STD
772-006	BLACK MATS WITH SINGLE INSULATION			STD
785-001	DASH MOUNTED ASH TRAYS AND LIGHTER			\$18.00
691-008	FORWARD ROOF MOUNTED CONSOLE WITH UPPER STORAGE COMPARTMENTS WITHOUT NETTING			STD
694-010	IN DASH STORAGE BIN			STD
742-007	(2) CUP HOLDERS LH AND RH DASH			STD
680-006	GRAY/CHARCOAL FLAT DASH			STD
720-003	5 LB. FIRE EXTINGUISHER	10		\$84.00
700-002	HEATER, DEFROSTER AND AIR CONDITIONER	70		\$1,050.00
701-001	STANDARD HVAC DUCTING			STD
703-005	MAIN HVAC CONTROLS WITH RECIRCULATION SWITCH			N/C
170-015	STANDARD HEATER PLUMBING			STD
130-033	DENSO HEAVY DUTY AIR CONDITIONER COMPRESSOR			N/C
702-002	BINARY CONTROL, R-134A			N/C
739-001	CAB INSULATION			STD
285-013	SOLID-STATE CIRCUIT PROTECTION AND FUSES			STD
280-007	12V NEGATIVE GROUND ELECTRICAL SYSTEM			STD
324-014	DOME LIGHT WITH 3-WAY SWITCH ACTIVATED BY LH AND RH DOORS			STD
655-001	CAB DOOR LATCHES WITH MANUAL DOOR LOCKS			STD
722-002	TRIANGULAR REFLECTORS WITHOUT FLARES	10		\$25.00
756-081	BOSTROM T910 HIGH BACK AIR SUSPENSION DRIVER SEAT	40		\$264.00
760-235	2 MAN TOOL BOX MID BACK NON SUSPENSION PASSENGER SEAT	30		\$263.00
711-004	LH AND RH INTEGRAL DOOR PANEL ARMRESTS			STD
758-036	VINYL WITH VINYL INSERT DRIVER SEAT			STD





Prepared for:  
Tara Lyle  
WV Prison Industries  
617 Leon Sullivan Way  
Charleston, WV 25301  
Phone: 304-558-2544

Prepared by:  
Jackie Cummings  
MATHENY MOTOR TRUCK  
COMPANY  
50 Mtheny Lane  
Mineral Springs, WV 26150  
Phone: 3044854418

Data Code	Description	Weight Front	Weight Rear	Retail Price
761-036	VINYL WITH VINYL INSERT PASSENGER SEAT			STD
763-006	3 POINT DRIVER AND PASSENGER AND 2 POINT CENTER FRONT SEAT BELT RETRACTORS			N/C
532-002	ADJUSTABLE TILT AND TELESCOPING STEERING COLUMN	10		\$478.00
540-015	4-SPOKE 18 INCH (450MM) STEERING WHEEL			STD
765-002	DRIVER AND PASSENGER INTERIOR SUN VISORS			STD
<b>Instruments &amp; Controls</b>				
732-004	GRAY DRIVER INSTRUMENT PANEL			STD
734-004	GRAY CENTER INSTRUMENT PANEL			STD
870-001	BLACK GAUGE BEZELS			STD
486-001	LOW AIR PRESSURE LIGHT AND BUZZER			N/C
840-002	2 INCH PRIMARY AND SECONDARY AIR PRESSURE GAUGES			N/C
198-025	INTAKE MOUNTED AIR RESTRICTION INDICATOR WITHOUT GRADUATIONS			STD
149-013	ELECTRONIC CRUISE CONTROL WITH SWITCHES IN LH SWITCH PANEL			STD
156-007	KEY OPERATED IGNITION SWITCH AND INTEGRAL START POSITION; 4 POSITION OFF/RUN/START/ACCESSORY			STD
811-011	ODOMETER/TRIP/HOUR/DIAGNOSTIC/VOLTAGE DISPLAY: 1X7 CHARACTER, 26 WARNING LAMPS, DATA LINKED, ICU3			STD
160-025	DIAGNOSTIC INTERFACE CONNECTOR, 9 PIN, SAE J1939, LOCATED BELOW DASH			STD
844-001	2 INCH ELECTRIC FUEL GAUGE			STD
148-003	PROGRAMMABLE RPM CONTROL - ELECTRONIC ENGINE			STD
856-001	ELECTRICAL ENGINE COOLANT TEMPERATURE GAUGE			STD
864-005	TRANSMISSION OIL TEMPERATURE INDICATOR LIGHT			STD
830-017	ENGINE AND TRIP HOUR METERS INTEGRAL WITHIN DRIVER DISPLAY			STD
852-002	ELECTRIC ENGINE OIL PRESSURE GAUGE			STD
746-1A2	AM/FM/WB RADIO WITH FRONT AUXILIARY INPUT	10		\$320.00
747-001	DASH MOUNTED RADIO			N/C
750-002	(2) RADIO SPEAKERS IN CAB			N/C
753-001	AM/FM ANTENNA MOUNTED ON FORWARD LH ROOF	2		N/C



Prepared for:  
 Tara Lyle  
 WV Prison Industries  
 617 Leon Sullivan Way  
 Charleston, WV 25301  
 Phone: 304-558-2544

Prepared by:  
 Jackie Cummings  
 MATHENY MOTOR TRUCK  
 COMPANY  
 50 Mtheny Lane  
 Mineral Springs, WV 26150  
 Phone: 3044854418

Data Code	Description	Weight Front	Weight Rear	Retail Price
810-027	ELECTRONIC MPH SPEEDOMETER WITH SECONDARY KPH SCALE, WITHOUT ODOMETER			STD
817-001	STANDARD VEHICLE SPEED SENSOR			STD
812-001	ELECTRONIC 3000 RPM TACHOMETER			STD
162-011	IDLE LIMITER, ELECTRONIC ENGINE			STD
883-998	NO TRAILER HAND CONTROL BRAKE VALVE			STD
836-015	DIGITAL VOLTAGE DISPLAY INTEGRAL WITH DRIVER DISPLAY			STD
660-008	SINGLE ELECTRIC WINDSHIELD WIPER MOTOR WITH DELAY			STD
304-001	MARKER LIGHT SWITCH INTEGRAL WITH HEADLIGHT SWITCH			STD
882-009	ONE VALVE PARKING BRAKE SYSTEM WITH WARNING INDICATOR			N/C
299-013	SELF CANCELING TURN SIGNAL SWITCH WITH DIMMER, WASHER/WIPER AND HAZARD IN HANDLE			STD
298-039	INTEGRAL ELECTRONIC TURN SIGNAL FLASHER WITH HAZARD LAMPS OVERRIDING STOP LAMPS			STD

#### Design

065-000	PAINT: ONE SOLID COLOR			STD
---------	------------------------	--	--	-----

#### Color

980-5F6	CAB COLOR A: L0006EB WHITE ELITE BC			STD
986-020	BLACK, HIGH SOLIDS POLYURETHANE CHASSIS PAINT			STD
962-970	VENDOR WHITE FRONT WHEELS/RIMS (PW, TKWHT21, W, TW)			STD
966-970	VENDOR WHITE REAR WHEELS/RIMS (PW, TKWHT21, W, TW)			STD
964-6Z7	BUMPER PAINT: FP24812 ARGENT SILVER DUPONT FLEX			STD

#### Certification / Compliance

996-001	U.S. FMVSS CERTIFICATION			STD
---------	--------------------------	--	--	-----

#### Sales Programs

NO SALES PROGRAMS HAVE BEEN SELECTED

### TOTAL VEHICLE SUMMARY

#### Adjusted List Price





Prepared for:  
 Tara Lyle  
 WV Prison Industries  
 617 Leon Sullivan Way  
 Charleston, WV 25301  
 Phone: 304-558-2544

Prepared by:  
 Jackie Cummings  
 MATHENY MOTOR TRUCK  
 COMPANY  
 50 Mtheny Lane  
 Mineral Springs, WV 26150  
 Phone: 3044854418

Adjusted List Price \*\* \$102,516.00

**Weight Summary**

	Weight Front	Weight Rear	Total Weight
Factory Weight <sup>+</sup>	6440 LBS	3719 LBS	10159 LBS
Dealer Installed Options	0 LBS	0 LBS	
<b>Total Weight<sup>+</sup></b>	<b>6440 LBS</b>	<b>3719 LBS</b>	<b>10159 LBS</b>

**ITEMS NOT INCLUDED IN ADJUSTED LIST PRICE**

**Other Factory Charges**

DELIVERY & ORDER PROCESSING CHARGE \$1,925.00

**Dealer Installed Options**

	Weight Front	Weight Rear	Price
BODY 24 FT BODY AND LIFTGATE	0	0	\$14,737.00
FRT FREIGHT FROM US TRUCK TO NITRO	0	0	\$850.00
SPOTS ON SPOTS	0	0	\$2,000.00
<b>Total Dealer Installed Options</b>	<b>0 LBS</b>	<b>0 LBS</b>	<b>\$17,587.00</b>

(+) Weights shown are estimates only.

If weight is critical, contact Customer Application Engineering.

(\*\*) Prices shown do not include taxes, fees, etc... "Net Equipment Selling Price" is located on the Quotation Details Proposal Report.





**Prepared for:**  
Tara Lyle  
WV Prison Industries  
617 Leon Sullivan Way  
Charleston, WV 25301  
Phone: 304-558-2544

**Prepared by:**  
Jackie Cummings  
MATHENY MOTOR TRUCK  
COMPANY  
50 Mtheny Lane  
Mineral Springs, WV 26150  
Phone: 3044854418





Freightliner (FTL)



## Freightliner Medium-Duty/Business Class

Description	Coverage	
	Time <sup>1</sup>	Distance <sup>1</sup>
Basic Vehicle	2 Years	Unlimited
Battery	1 Year	100,000 mi/161 000 km
Brightwork	6 Months	Unlimited
Cab Corrosion/Perforation	5 Years	Unlimited
Cab Structure	2 Years	Unlimited
Chassis Paint	6 Months	Unlimited
Corrosion	6 Months	Unlimited
Crossmembers	5 Years	Unlimited
Drivetrain	2 Years	Unlimited
Frame Rails	5 Years	Unlimited
Paint	1 Year	100,000 mi/161 000 km
Steer Axle <sup>2</sup>	2 Years	Unlimited

<sup>1</sup>Time or distance, whichever comes first

<sup>2</sup>Steer axle coverage-group applies to glider only.

**Warranty Statement & Warranty Coverage Descriptions follow on page two of this document.**

*The information provided in this document is for general information only and is not offered as customer's warranty.*

*This coverage may be superseded without notification.*

*Copyright © Daimler Trucks North America LLC. All rights reserved. Daimler Trucks North America LLC is a Daimler company.*

## Warranty Statement

### 1.00 NEW VEHICLE COVERAGE

The following section outlines Company standard warranty coverages for all Company vehicles, apparatus or chassis or cabs sold and domiciled in the USA (50 states and Washington, D.C.), Puerto Rico, and Canada. This information is also included in the Operator's Maintenance and Owner's Warranty Information Booklet.

### 1.01 NEW VEHICLE LIMITED WARRANTY

Under this New Vehicle Limited Warranty ("Warranty"), Company warrants that each new vehicle will be free from defects in material and workmanship that occur under normal use within the applicable warranty period, subject to certain limitations and exclusions as specified in this document.

This Warranty covers all components and parts unless specifically covered by other warranties or otherwise excluded by this document.

### 1.02 LIMITATIONS

This Warranty does not apply to vehicles that are sold or domiciled outside of the United States (50 states and Washington, D.C.), Puerto Rico, or Canada.

This Warranty does not apply to engines, Allison or Twin Disc transmissions, tires, or other components or parts that are not manufactured by Company and that are warranted directly by their respective manufacturers. With respect to the foregoing, Company makes no warranty whether express, implied, statutory or otherwise including, but not limited to, any warranty of merchantability or fitness for a particular purpose.

THIS WARRANTY IS EXCLUSIVE AND IN LIEU OF ALL OTHER WARRANTIES OF ANY KIND WHETHER WRITTEN, ORAL, OR IMPLIED INCLUDING, BUT NOT LIMITED TO ANY WARRANTY OF MERCHANTABILITY OR FITNESS FOR A PARTICULAR PURPOSE. THIS WARRANTY SPECIFICALLY EXCLUDES ANY OTHER WARRANTIES OR CONDITIONS PROVIDED FOR BY LAW, WHETHER STATUTORY OR OTHERWISE.

COMPANY'S SOLE OBLIGATION UNDER THIS WARRANTY SHALL BE TO REPAIR OR REPLACE, IN COMPANY'S SOLE DISCRETION, ANY DEFECTIVE COMPONENT OR PART. SUCH REPAIR OR REPLACEMENT SHALL BE WITHOUT COST TO PURCHASER WHEN PERFORMED WITHIN THE APPLICABLE WARRANTY PERIOD (TIME, DISTANCE, OR HOUR LIMIT, WHICHEVER OCCURS FIRST).

Purchaser must notify Company within the applicable warranty period, of any failure of the vehicle to comply with this Warranty and Purchaser must, at Purchaser's expense, promptly return the vehicle to an authorized Dealer for inspection and repair or replacement of any defect in material or workmanship occurring within the applicable warranty period.

The vehicle must be maintained and serviced according to the prescribed schedules outlined in the Driver's/Operator's and Maintenance Manuals. Receipted bills and other evidence that required maintenance and service have been performed are required by Company as a condition of this Warranty.

After the Company's obligations under this Warranty expire, all liabilities of Company to Purchaser under this Warranty shall terminate. Repairs made under this Warranty do not constitute an extension of the original Warranty period for the vehicle or for any specific component or part.

To the extent that any provision of this Warranty contravenes the law of any jurisdiction, such provision shall be inapplicable in such jurisdiction, and the remainder of the warranty shall not be affected.

### 1.03 PURCHASER'S EXCLUSIVE REMEDY

THIS WARRANTY SHALL BE THE PURCHASER'S SOLE AND EXCLUSIVE REMEDY AGAINST COMPANY, WHETHER IN CONTRACT, UNDER STATUTE (INCLUDING STATUTORY PROVISIONS AS TO CONDITIONS AS TO QUALITY OR FITNESS FOR ANY PARTICULAR PURPOSE OF GOODS SUPPLIED PURSUANT TO THE CONTRACT OF SALE), WARRANTY, TORT, STRICT LIABILITY, OR ANY OTHER LEGAL THEORY.

### 1.04 LIMITATION OF LIABILITY

COMPANY'S LIABILITY UNDER THIS WARRANTY IS LIMITED TO THE COST TO REPAIR OR REPLACE, IN COMPANY'S SOLE DISCRETION, THE DEFECTIVE COMPONENT OR PART THAT IN NO EVENT SHALL EXCEED THE FAIR MARKET VALUE OF THE VEHICLE AT THE TIME THE DEFECT IS DISCOVERED.

IN NO EVENT SHALL COMPANY BE LIABLE FOR SPECIAL, INDIRECT, INCIDENTAL, OR CONSEQUENTIAL DAMAGES INCLUDING, BUT NOT LIMITED TO, INJURIES TO PERSONS OR DAMAGE TO PROPERTY, LOSS OF PROFITS OR ANTICIPATED PROFITS, OR LOSS OF VEHICLE USE.

## Coverage Descriptions

### Axles

Coverage includes all factory-installed steer axles; drive axles; tag axles; and pusher axles. *Excludes any axle installed by a dealer or body builder.*

#### Drive Axle(s)

Coverage includes axle housing, carrier assembly, differential assembly, power divider, axle shafts, and gaskets and seals. *Excludes suspension and torque rod brackets, tie rod ends, wheel end equipment, wiring, yokes, and attaching hardware.*

#### Pusher Axle

A pusher axle is a non-driven, weight-bearing axle that can be raised when not required to bear a portion of the load. Since the pusher axle can be of many different configurations, warranty coverage includes all components included in the individual build specification of each individual application.

#### Steer Axle

Coverage includes I-beam, steering knuckles, differential on drive steer axle, spindles, kingpins, kingpin bearings and steering arms. *Excludes wheel end equipment, tie rod ends, steering linkage components, kingpin bushings, and king pin seals.*

#### Tag Axle

A tag axle is a non-driven, continuous weight-bearing axle. Since the tag axle can be of many different configurations, warranty coverage includes all components included in the individual build specification of each individual application.

### Battery

Only Freightliner LLC's private brand-label (Alliance Brand Parts), Mopar (Sterling Bullet only), and Furukawa (STL360 Model only) batteries will be warranted. *Any other brand of battery is excluded from Company coverage. Claims for all other brands must be submitted directly to the supplier. Warranty coverage includes the battery assembly only.*

### Basic Body

Coverage includes body emergency lighting and controls; hinged and rollup compartment doors; body trim; body lighting and controls; body electrical systems.

### Basic Chassis

Coverage includes all factory-installed components of the vehicle/chassis that are not excluded elsewhere in the warranty, or by special agreement or described as having a different time, or distance or hours, or listed separately on each new vehicle warranty coverage chart.

### Basic Vehicle

Coverage includes all factory-installed components of the vehicle/chassis that are not excluded elsewhere in the warranty, or by special agreement or described as having a different time or distance, or listed separately on each new vehicle warranty coverage chart.

### Body Electrical

Coverage includes body wiring harness(es) only.

### Body Structure

Coverage includes compartments and body panels; hinged compartment doors; fire pump closure; body frame and sub-frame, if applicable. *Excludes surface corrosion caused by chips or scratches.*

### Body Structure and Corrosion

Coverage includes compartments and body panels; hinged compartment doors; fire pump closure; body frame and sub-frame, if applicable. *Excludes surface corrosion caused by chips or scratches.*

### Brightwork

Coverage includes all factory-installed components with chrome, polished aluminum, or polished stainless steel surfaces. *Excludes any damage to bumper, backside of bumpers, and concealed or inner surfaces.*

### Cab Corrosion/Perforation

Coverage is limited to rust-through or perforation of the cab and integral sleeper structure and sleeper box (if applicable) due to corrosion from within. *Excludes all conditions of rust or corrosion that has not resulted in rust-through or perforation as well as surface rust or corrosion caused by non-adhesion. Excludes any damage to the paint such as chips or scratches.*

### Cab Structure

Coverage includes cab and integral sleeper structural components, structural components of factory installed sleeper boxes (if applicable), sheet metal panels, doors, and hoods. *Excludes all bolt-on components including door and hood hinges, latches, guides, and other mounting hardware.*

### Corrosion

Coverage provides warranty against corrosion to any metal or metal alloy part of the vehicle. Rust or corrosion to specific components and/or caused by certain conditions are excluded from all Company warranty coverage and will not be paid under Basic Vehicle, Cab Structure, Cab Corrosion, or Aftermarket Parts Warranty.

Exclusions to corrosion warranty include, but are not limited to, the following:

- Corrosion caused by general rust (for example, rust on the unfinished backside of a bumper)
- Surface rust caused by chips or scratches in the paint or chrome surfaces
- Corrosion caused by high-pressure washing, severe wash solutions, cleaning solvents, detergents, compounds
- Corrosion caused by salinity in the environment or corrosive salts and/or chemicals used on the road surface.
- Corrosion caused by acid rain or other industrial fallout
- Corrosion due to improper prevention measures during storage or use

- Corrosion or rust on tone rings, rotors or drums (rotor exclusion does not apply to hydraulic discs with Magna-Coat Rotors)

- Corrosion due to environmental damage (including ocean spray); airborne fallout (includes chemicals, tree sap, etc.); or other atmospheric conditions or other acts of nature

- Corrosion due to improper use, misuse or abuse, negligence, including improper or insufficient maintenance

### Cowl Corrosion/Perforation

Coverage is limited to rust-through or perforation of the cowl due to corrosion from within. *Excludes all conditions of rust or corrosion that have not resulted in rust-through or perforation as well as surface rust or corrosion caused by non-adhesion. Excludes any damage to the paint such as chips or scratches.*

### Cowl Structure

Coverage includes cowl structural components, sheet metal panels, and hood. *Excludes all bolt-on components including hood hinges, latches, guides, or other mounting hardware.*

### Crossmembers

Coverage includes crossmembers, gussets, and huck-mounting bolts that attach gussets to crossmembers and gussets/crossmembers to frame rails. *Excludes any bolt-on item attached with either conventional or huck bolts.*

### Driveline

Coverage includes driveshaft tubing, U-joints, yokes, support bearings, and splines.

### Drivetrain

Coverage includes transmission, (except Allison transmissions) steer axle(s), drive axle(s), and transfer case. *Excludes tag axle(s), pusher axle(s), driveline, and U-joints.*

### Frame Rails

Coverage is limited to breaking or cracking of factory installed frame rails, frame rail liners, frame rail extensions, and any item(s) factory welded to them. *Excludes all bolt-on items regardless if attached with conventional or huck bolts.*

### Glider

An incomplete vehicle which may be ordered with or without engine and/or major drive train components; warranty coverage includes all components as specified in the specific build specification.

### Off Road On-Site Assistance

Coverage is exclusively available for off road vehicles that are prohibited from use on public streets. If this coverage is provided, it will be specifically included in the coverage table as a separate category. Coverage includes on-site assistance and/or equipment transportation to the nearest authorized repairing location for a Daimler Trucks North America LLC warrantable repair.

### Paint (Body, Cab, & Cowl)

*Paint coverage excludes lack-of-gloss issues on vehicles painted with low gloss colors; the underside of hoods and roof and side mounted air fairings; and any damages to the paint or painted surface such as chips and scratches.*

#### Body Paint

Coverage includes all factory-painted exterior body surfaces. Warranted against orange peel; peeling/delaminating; cracking or checking; or loss of gloss due to cracking, checking or hazing.

#### Cab Paint

Coverage includes all factory-painted exterior surfaces (except those included in chassis paint coverage). Warranted against orange peel, peeling or delaminating; cracking or checking; or loss of gloss due to cracking, checking or hazing.

#### Cowl Paint

Coverage includes all factory-painted exterior surfaces of cowl structure (except those included in chassis paint). Warranted against orange peel; peeling or delaminating; cracking or checking; or loss of gloss due to cracking, checking or hazing.

### Paint, Chassis (Chassis Paint)

Coverage includes all factory painted surfaces on frame rails, crossmembers/gussets, front and rear bumpers, suspension components, power train components, drivelines, fuel tanks, air tanks, wheel end equipment, tool boxes, battery boxes, access steps, and attaching brackets and hardware. Warranted against peeling or non-adhesion. *Excludes U-joints and any damages to the paint or painted surface such as chips and scratches.*

### Towing/Roadside Assistance

Coverage includes roadside assistance or towing (to the nearest authorized repair location) for a Daimler Trucks North America LLC warrantable repair in a vehicle-down situation that prevents the safe and lawful operation of the vehicle. If this coverage is provided, it will be specifically included in the coverage table as a separate category.

### Transfer Case Assembly

Coverage includes housing and all internally lubricated parts.

### Transmission

Coverage includes housing and all internally lubricated parts; electric/air shift/control units, valves, gaskets, and seals. Excludes broken synchronizer pins, PTOs, transfer case(s), airlines, gauge senders, yoke(s), clutch and clutch control components including clutch brake. *Excludes Allison automatic transmissions and Twin Disc Automatic Transmissions.*

### Wheel End Equipment

Coverage includes brake components, wheels, hubs, drums, rotors, wheel seals/ bearings, slack adjusters, and attaching hardware.



1807 N. Bloomington St.  
 Streator, IL 61364  
 Ph: 815-672-3211 or 800-443-0843  
 Fax: 815-672-1490  
[sales@ustruckbody.com](mailto:sales@ustruckbody.com)

Matheny Motor Truck Co.  
 4125 1st Avenue  
 Nitro ,WV 25143  
[jcumplings@mathenymotors.com](mailto:jcumplings@mathenymotors.com)  
 Attn: Jack Cummings  
 Quantity: 1

Date: 1/30/2012  
 Quote #: MD27898  
 revised (2)  
 Model: VA 24 96 96  
 Phone: (304) 769 5860  
 Fax:

## ALUMINUM VAN BODY QUOTATION

LENGTH: 24' I.D.    WIDTH: 96" O.D.    HEIGHT: 96" I.D.

Construction:	(.040) Pre-painted white aluminum panels with high strength extruded aluminum (not steel) "Z" posts on 16" centers. Seven front wall posts (not five) for added strength and durability. Extruded aluminum front corner radius posts, (not roll formed) for maximum strength.
Roof:	(.060) translucent roof panel with anti-snag roof bows on 24" centers, "Zephyr" 12" fuel saving roof radius design with heavy-duty cast aluminum (not plastic) corner castings.
Rear Frame:	11 Ga. Galvaneal steel, internally and externally reinforced, and gusseted at all stress points, painted to match.
Side Door(s):	None.
Rear Door:	Standard plastic covered ¼" plywood roll up, 88" wide x 90.5" high clear opening. Stainless steel rivets and "E" coated hardware.
Rear:	Interlift ILP-33 tuck under liftgate, 3300 lb. capacity 80" x 48" aluminum platform, level ride operation, HD 2 step dock bumper with rubber blocks, cab cut off switch.
Grab Handle(s):	Curb side and road side on rear frame.
Rear Lighting:	Utilize OEM tail lights.
Floor:	1-1/8" high quality domestic laminated hardwood. 24" x 1/8" steel threshold plate at rear, with front edge routed into flooring.
Cross members:	3" steel I-Beam cross members on 12" centers with full steel wheel pan support over wheel area.
Interior Sides:	Sides - 3/8" full height premium plywood.
Interior Front:	Front - 1/2" full height premium plywood.
Interior Ties:	Sides - Two (2) row(s) recessed "E" Track @ ___ & ___" on center. Front - None.









# ILP PALLET PRO

2500 and 3300 lbs. Capacity

**MBB PALFINGER**

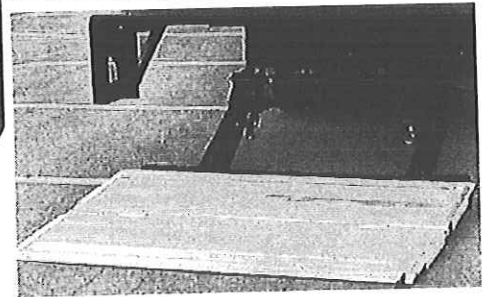
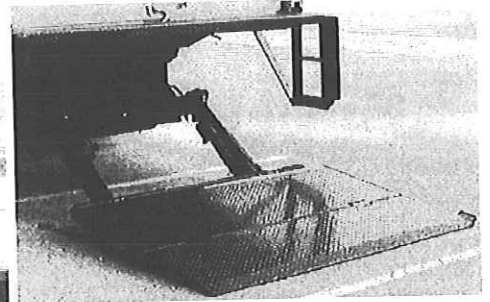
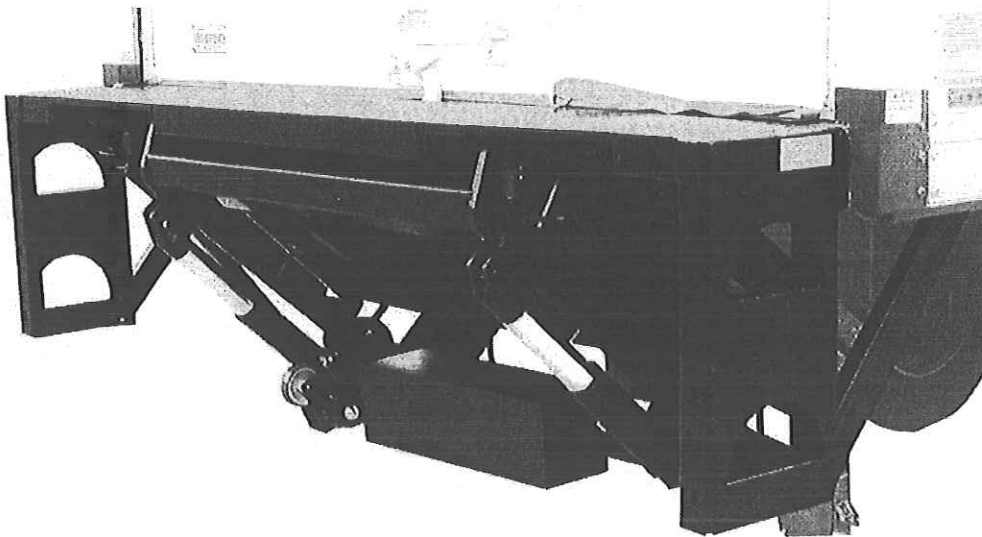

**-OPTIMIZED-**  
FLEXIBILITY  
DURABILITY  
PROFITABILITY

The ILP Pallet Pro provides a lot of value for a small premium. Level ride platforms available in a variety of sizes from 48", 54", 60" x 80". Units are available in several steel and aluminum combinations.  
**LARGE Platform Lift! SMALL Platform Price!**

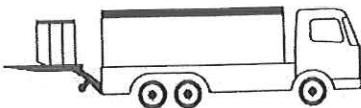

## HEAVY DUTY CONSTRUCTION

- Bushings & zerks at all pivot points
- Heat treated pins
- Wide lift arm:
  - Provides added stability
  - Accepts a fixed hitch
- Thermo protected powerpack
- Increases life of components
- 150 AMP circuit breaker

## BUILT IN STANDARD/ SAFETY FEATURES

- Dual cylinder stability
- Cab shut off switch
- Hydraulic cylinder locks on cylinder ports
- Adjustable roller and dual torsion assist offer minimum effort for platform folding
- Level ride platform
- Wide bed height range:
  - The 48" platform unit can be installed on as low as 38" laden bed height/up to 53" unladen



# MBB PALFINGER

Built to Deliver - Every Time

Interlift Inc. dba MBB Palfinger  
 15939 Piuma Avenue  
 Cerritos, CA, 90703  
 Tel: 1-562-924-8218  
 Toll Free: 1-888-774-5844  
 Fax: 1-562-924-8318  
 www.interlift.net

The MBB PALFINGER Pallet Pro, offering a platform size, level ride and lift capacity to handle many palletized or carted freight safely at a budget price.

MBB PALFINGER liftgates are pre-filled with aerospace hydraulic fluid. Our standard hydraulic cylinder lock provides added stability, better user control and improved safety.

The two cylinder mid arm design can accommodate a fixed receiver hitch. The platform rotates on an adjustable roller to adapt for different bed height installations.

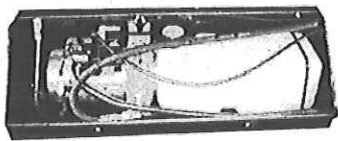

The thermo protected PowerPack is fully enclosed in a H/D powder coated steel box for protection and easy inspection. By using over sized quality components, we minimize maintenance and downtime.

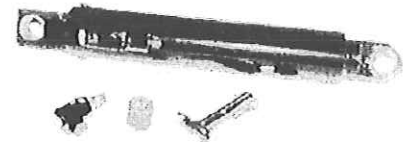

The ILP incorporates our double torsions on both the main and folded section. The unique leveling joint on the ILP does not rotate on the ground. This makes the ILP an exceptionally smooth operating lift.

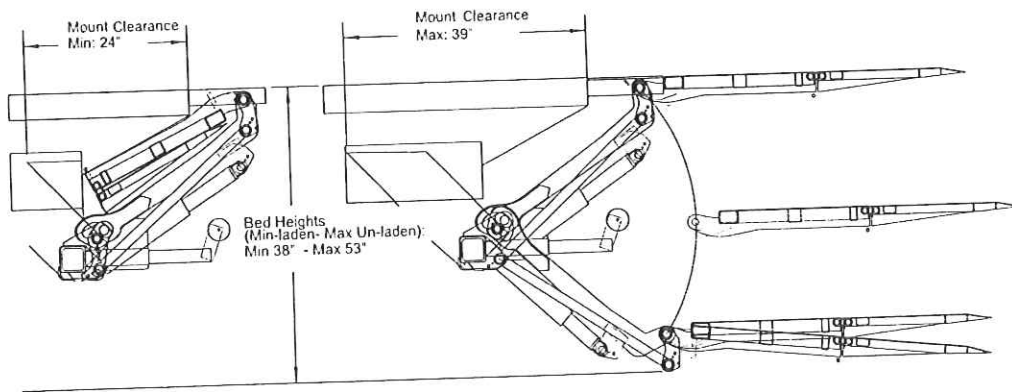

### LIFTGATE OPTIONS:

- Auxiliary truck and trailer kits
- Dock bumpers
- Rubber pads
- Cart stops
- DOT rear impact guard
- Extra heavy duty trailer dock bumpers
- Hand held remote
- Aluminum tip sections
- All aluminum platforms
- Wireless remote
- 2" Receiver hitch

Model	Lifting Capacity (lbs)	Platform Length (inches)	Platform Width (inches)	Bed Height (inches)	Approx. Weight (lbs)	Mount Clearance (inches)
ILP 25	2500	48	80	38 - 53	750	21 - 30
ILP 33	3300	48	80	38 - 53	840	21 - 30
ILP 33	3300	54	80	45 - 55	900	24 - 34
ILP 33	3300	60	80	45 - 55	930	24 - 34

Applications shown in the leaflet do not always correspond to the standard specifications. Design and specification are subject to change without prior notice.



# 28 REASONS TO CHOOSE

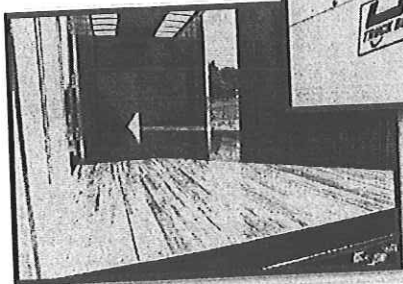
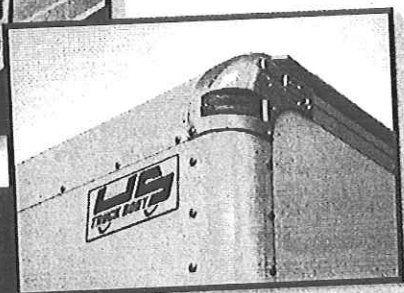
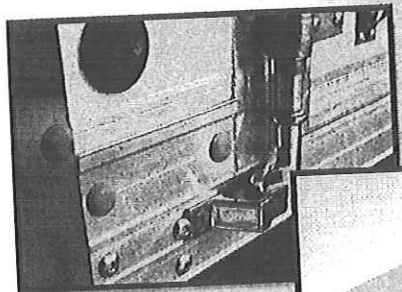

Since 1945, U.S. TRUCK BODY has been providing the transportation industry with high quality van bodies. There are many reasons to choose U.S. TRUCK BODY over our competition, but here we are going to present just 28. Let us show you how our bodies will add value to your operation. Give us a shot to quote your next van body purchase.





# WHY U.S. TRUCK BODY IS THE BEST IN CLASS VAN BODY BUILDER

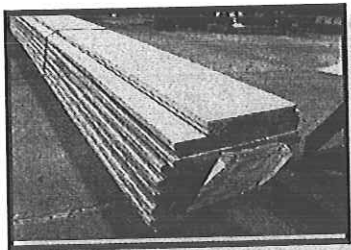
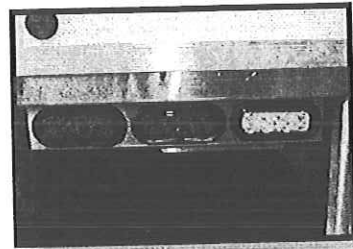
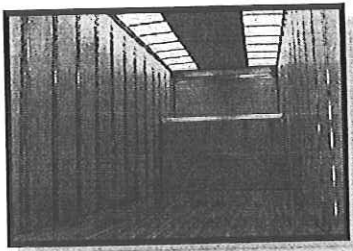
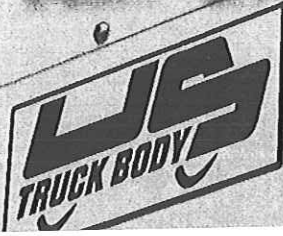

1. Front corner radius is constructed of 1/8" aluminum extrusion (not roll formed).
2. Aluminum model has seven posts (not five) on front wall for maximum strength.
3. Shortest lead times in the industry.
4. Flooring is high quality domestic laminated hardwood (not pine or Malaysian).
5. Aluminum model has solid rivet spacing on 2.5" centers on every (not every other) seam.
6. Front corner castings are heavy duty aluminum (not plastic or composite) for longer life.
7. Decades and decades of experienced staff to assist with every van body specification and application.
8. DuraPlate panel (not plymetal) construction on all side and rear swing doors.
9. Fastest turn around on quotes in the industry.
10. Front wall scuff plate extends below floor welded to understructure.
11. Premium stainless steel (not zinc coated) bar lock hardware on rear swing doors.
12. Red and white LED lamps are standard with tail lights in rear frame option.
13. Dock bumpers are steel reinforced (not wood filled) with standard rubber bumpers.
14. Longitudinals are gusseted to every (not alternating) cross member.
15. Standard model roll up door has E coated hardware and stainless steel rivets.
16. Steel crush pipes installed on U bolts to prevent chassis frame damage.
17. Hardwood filler boards are steel banded to frame rails for no movement.
18. Front 10" roof radius designed for maximum air flow & fuel efficiency.
19. Tapered (not a trough) rear threshold prevents rot and water seepage from bumper.
20. Stainless steel rear frame is standard on all rear swing door equipped bodies.
21. Undercoating is heavy petroleum based (not just paint) on full understructure.
22. Exclusive underbody handles are standard equipment on all side doors.
23. Heavy duty extruded aluminum hinges on all swing doors.
24. Only stainless steel bolts, screws and aluminum fasteners used in construction.
25. All wiring is enclosed in plastic loom to protect against contact wear.
26. Pre-build available of some models pending chassis arrival.
27. No extra charge for translucent roof panel in lieu of aluminum panel.
28. Two 5/16" (not 1/4" or smaller) screws per board into flooring at every crossmember.



U.S. Truck Body • 1807 North Bloomington St. • Streator, IL 61364  
 Ph: 800-4430-0843 • 815-672-3211 • Fx: 815-672-1490  
 E-mail: sales@ustruckbody.com • Web: www.ustruckbody.com





## **U.S. TRUCK BODY 5-YEAR LIMITED WARRANTY**

U.S. Truck Body warrants its FRP, aluminum and Freight Plate bodies, to the original purchaser, to be free from defects in material and workmanship for five (5) years from the date of delivery. Warranted for one year from date of delivery, are wood flooring, exterior paints and other finishes, wiring installation, caulking and protection against water leaks. Products and parts which are sold by U.S. Truck Body but not manufactured by U.S. Truck Body are not warranted by U.S. Truck Body, but are sold only with the warranties, if any, of the applicable manufacturer thereof. U.S. Truck Body hereby assigns to Purchasers, to the extent assignable, the applicable manufacturer's warranty for such products not manufactured by U.S. Truck Body. This Limited Warranty does not cover any problems that result from U.S. Truck Body bodies being subject to "Abnormal Usage". By "Abnormal Usage" U.S. Truck Body means that the body is used in the manner and for the purposes which the applicable body is not intended to be used. This Limited Warranty does not cover damage, without limitation, resulting from corrosive, hazardous or inherently unsafe cargo; or minor imperfections or defects which do not generally impair or affect the fair market value of the body or its suitability for its intended use; or damage or defects attributable to normal wear and usage.

Specifically excluded, without limitation are any and all warranties of merchantability and of fitness for a particular purpose. U.S. Truck Body shall not be liable for any amount in excess of the truck body purchase price, and in no event for special, indirect, consequential or incidental damages arising out of, or in connection with this warranty or the U.S. Truck Body bodies hereunder. No party shall make any repair under this warranty without the prior written consent of U.S. Truck Body. If U.S. Truck Body requests it, purchaser at its cost shall deliver the defective truck body to U.S. Truck Body or its designee for repairs.

Any claim under this warranty must be made within thirty (30) days from the date such claim should reasonably been discovered. Timeliness of notification being of the essence, Purchaser's late notification relieves U.S. Truck Body of all liability hereunder.

