



State of West Virginia
 Department of Administration
 Purchasing Division
 2019 Washington Street East
 Post Office Box 50130
 Charleston, WV 25305-0130

Request for Quotation

RFQ NUMBER
PR111561

PAGE
1

ADDRESS (CORRESPONDENCE TO ATTENTION OF):
TARA LYLE 304-558-2544

VEZOR

*427103343 304-776-5600
 Heritage International Trucks, Inc.
 408 Goff Mountain Road
 Cross Lanes, WV 25313

SHIP TO

WV PRISON INDUSTRIES
 617 LEON SULLIVAN WAY
 CHARLESTON, WV
 25301 304-558-2945

DATE PRINTED	TERMS OF SALE	SHIP VIA	F.O.B.	FREIGHT TERMS
01/09/2012				

BID OPENING DATE: 02/16/2012 BID OPENING TIME 01:30PM

LINE	QUANTITY	UOP	CAT NO	ITEM NUMBER	UNIT PRICE	AMOUNT
0001	1	EA		070-53	\$84,447.15	\$84,447.15
DELIVERY TRUCK THE WEST VIRGINIA PURCHASING DIVISION FOR THE AGENCY, WEST VIRGINIA CORRECTIONAL INDUSTRIES, IS SOLICITING BIDS FOR ONE (1) 2011 OR NEWER DELIVERY TRUCK, PER THE ATTACHED SPECIFICATIONS. INQUIRIES: WRITTEN QUESTIONS WILL BE ACCEPTED UNTIL CLOSE OF BUSINESS ON 01/31/2012. QUESTIONS MAY BE SENT VIA USPS, FAX, COURIER OR E-MAIL. IN ORDER TO ASSURE NO VENDOR RECEIVES AN UNFAIR ADVANTAGE, NO SUBSTANTIVE QUESTIONS WILL BE ANSWERED ORALLY. IF POSSIBLE, E-MAIL QUESTIONS ARE PREFERRED. ADDRESS INQUIRIES TO: TARA LYLE DEPARTMENT OF ADMINISTRATION PURCHASING DIVISION 2019 WASHINGTON STREET, EAST CHARLESTON, WV 25305 FAX: 304-558-4115 EMAIL: TARA.L.LYLE@WV.GOV CANCELLATION: THE DIRECTOR OF PURCHASING RESERVES THE RIGHT TO CANCEL THIS CONTRACT IMMEDIATELY UPON WRITTEN NOTICE TO THE VENDOR IF THE COMMODITIES AND/OR SERVICES SUPPLIED ARE OF AN INFERIOR QUALITY OR DO NOT CONFORM						

RECEIVED
 2012 FEB 16 AM 11:07
 WV PURCHASING DIVISION

SEE REVERSE SIDE FOR TERMS AND CONDITIONS

SIGNATURE	TELEPHONE	DATE
<i>[Signature]</i>	304-776-5600	2-16-12
TITLE	FERN	ADDRESS CHANGES TO BE NOTED ABOVE
Sales Manager	27-1476356	

WHEN RESPONDING TO REQ INSERT NAME AND ADDRESS IN SPACE ABOVE LABELED 'VENDOR'

GENERAL TERMS & CONDITIONS REQUEST FOR QUOTATION (RFQ) AND REQUEST FOR PROPOSAL (RFP)

1. Awards will be made in the best interest of the State of West Virginia.
 2. The State may accept or reject in part, or in whole, any bid.
 3. Prior to any award, the apparent successful vendor must be properly registered with the Purchasing Division and have paid the required \$125 fee.
 4. All services performed or goods delivered under State Purchase Order/Contracts are to be continued for the term of the Purchase Order/Contracts, contingent upon funds being appropriated by the Legislature or otherwise being made available. In the event funds are not appropriated or otherwise available for these services or goods this Purchase Order/Contract becomes void and of no effect after June 30.
 5. Payment may only be made after the delivery and acceptance of goods or services.
 6. Interest may be paid for late payment in accordance with the **West Virginia Code**.
 7. Vendor preference will be granted upon written request in accordance with the **West Virginia Code**.
 8. The State of West Virginia is exempt from federal and state taxes and will not pay or reimburse such taxes.
 9. The Director of Purchasing may cancel any Purchase Order/Contract upon 30 days written notice to the seller.
 10. The laws of the State of West Virginia and the **Legislative Rules** of the Purchasing Division shall govern the purchasing process.
 11. Any reference to automatic renewal is hereby deleted. The Contract may be renewed only upon mutual written agreement of the parties.
 12. **BANKRUPTCY:** In the event the vendor/contractor files for bankruptcy protection, the State may deem this contract null and void, and terminate such contract without further order.
 13. **HIPAA BUSINESS ASSOCIATE ADDENDUM:** The West Virginia State Government HIPAA Business Associate Addendum (BAA), approved by the Attorney General, is available online at www.state.wv.us/admin/purchase/vrc/hipaa.html and is hereby made part of the agreement provided that the Agency meets the definition of a Cover Entity (45 CFR §160.103) and will be disclosing Protected Health Information (45 CFR §160.103) to the vendor.
 14. **CONFIDENTIALITY:** The vendor agrees that he or she will not disclose to anyone, directly or indirectly, any such personally identifiable information or other confidential information gained from the agency, unless the individual who is the subject of the information consents to the disclosure in writing or the disclosure is made pursuant to the agency's policies, procedures, and rules. Vendor further agrees to comply with the Confidentiality Policies and Information Security Accountability Requirements, set forth in <http://www.state.wv.us/admin/purchase/privacy/noticeConfidentiality.pdf>.
 15. **LICENSING:** Vendors must be licensed and in good standing in accordance with any and all state and local laws and requirements by any state or local agency of West Virginia, including, but not limited to, the West Virginia Secretary of State's Office, the West Virginia Tax Department, and the West Virginia Insurance Commission. The vendor must provide all necessary releases to obtain information to enable the director or spending unit to verify that the vendor is licensed and in good standing with the above entities.
 16. **ANTITRUST:** In submitting a bid to any agency for the State of West Virginia, the bidder offers and agrees that if the bid is accepted the bidder will convey, sell, assign or transfer to the State of West Virginia all rights, title and interest in and to all causes of action it may now or hereafter acquire under the antitrust laws of the United States and the State of West Virginia for price fixing and/or unreasonable restraints of trade relating to the particular commodities or services purchased or acquired by the State of West Virginia. Such assignment shall be made and become effective at the time the purchasing agency tenders the initial payment to the bidder.
- I certify that this bid is made without prior understanding, agreement, or connection with any corporation, firm, limited liability company, partnership, or person or entity submitting a bid for the same material, supplies, equipment or services and is in all respects fair and without collusion or Fraud. I further certify that I am authorized to sign the certification on behalf of the bidder or this bid.

INSTRUCTIONS TO BIDDERS

1. Use the quotation forms provided by the Purchasing Division. Complete all sections of the quotation form.
2. Items offered must be in compliance with the specifications. Any deviation from the specifications must be clearly indicated by the bidder. Alternates offered by the bidder as **EQUAL** to the specifications must be clearly defined. A bidder offering an alternate should attach complete specifications and literature to the bid. The Purchasing Division may waive minor deviations to specifications.
3. Unit prices shall prevail in case of discrepancy. All quotations are considered F.O.B. destination unless alternate shipping terms are clearly identified in the quotation.
4. All quotations must be delivered by the bidder to the office listed below prior to the date and time of the bid opening. Failure of the bidder to deliver the quotations on time will result in bid disqualifications: Department of Administration, Purchasing Division, 2019 Washington Street East, P.O. Box 50130, Charleston, WV 25305-0130
5. Communication during the solicitation, bid, evaluation or award periods, except through the Purchasing Division, is strictly prohibited (W.Va. C.S.R. §148-1-6.6).



State of West Virginia
 Department of Administration
 Purchasing Division
 2019 Washington Street East
 Post Office Box 50130
 Charleston, WV 25305-0130

Request for Quotation

RFQ NUMBER
PRI11561

PAGE
2

ADDRESS CORRESPONDENCE TO ATTENTION OF
TARA LYLE 304-558-2544

VENDOR

*427103343 304-776-5600
 Heritage International Trucks, Inc.
 408 Goff Mountain Road
 Cross Lanes, WV 25313

SHIP TO

WV PRISON INDUSTRIES
 617 LEON SULLIVAN WAY
 CHARLESTON, WV
 25301 304-558-2945

DATE PRINTED	TERMS OF SALE	SHIP VIA	F.O.B.	FREIGHT TERMS
01/09/2012				
BID OPENING DATE: 02/16/2012		BID OPENING TIME 01:30PM		

LINE	QUANTITY	UOP	CAT NO	ITEM NUMBER	UNIT PRICE	AMOUNT
<p>TO THE SPECIFICATIONS OF THE BID AND CONTRACT HEREIN.</p> <p>BANKRUPTCY: IN THE EVENT THE VENDOR/CONTRACTOR FILES FOR BANKRUPTCY PROTECTION, THE STATE MAY DEEM THE CONTRACT NULL AND VOID, AND TERMINATE SUCH CONTRACT WITHOUT FURTHER ORDER.</p> <p>THE MODEL/BRAND/SPECIFICATIONS NAMED HEREIN ESTABLISH THE ACCEPTABLE LEVEL OF QUALITY ONLY AND ARE NOT INTENDED TO REFLECT A PREFERENCE OR FAVOR ANY PARTICULAR BRAND OR VENDOR. VENDORS WHO ARE BIDDING ALTERNATES SHOULD SO STATE AND INCLUDE PERTINENT LITERATURE AND SPECIFICATIONS. FAILURE TO PROVIDE INFORMATION FOR ANY ALTERNATES MAY BE GROUNDS FOR REJECTION OF THE BID. THE STATE RESERVES THE RIGHT TO WAIVE MINOR IRREGULARITIES IN BIDS OR SPECIFICATIONS IN ACCORDANCE WITH SECTION 148-1-4(F) OF THE WEST VIRGINIA LEGISLATIVE RULES AND REGULATIONS.</p> <p>ANY INDIVIDUAL SIGNING THIS BID IS CERTIFYING THAT: (1) HE OR SHE IS AUTHORIZED BY THE BIDDER TO EXECUTE THE BID OR ANY DOCUMENTS RELATED THERE TO ON BEHALF OF THE BIDDER, (2) THAT HE OR SHE IS AUTHORIZED TO BIND THE BIDDER IN A CONTRACTUAL RELATIONSHIP, AND (3) THAT THE BIDDER HAS PROPERLY REGISTERED WITH ANY STATE AGENCIES THAT MAY REQUIRE REGISTRATION.</p> <p style="text-align: center;">VENDOR PREFERENCE CERTIFICATE</p> <p>THIS TEAM EXHIBIT HAS BEEN REPLACED BY THE ONLINE VERSION WHICH IS AVAILABLE HERE: HTTP://WWW.STATE.WV.US/ADMIN/PURCHASE/VRC/VENPREF.PDF</p> <p style="text-align: center;">NOTICE</p>						

SEE REVERSE SIDE FOR TERMS AND CONDITIONS

GNATURE	TELEPHONE	DATE
	304-776-5600	2-16-12
TITLE	FEIN	ADDRESS CHANGES TO BE NOTED ABOVE
Sales Manager	27-1476356	

WHEN RESPONDING TO RFQ, INSERT NAME AND ADDRESS IN SPACE ABOVE LABELED 'VENDOR'



State of West Virginia
 Department of Administration
 Purchasing Division
 2019 Washington Street East
 Post Office Box 50130
 Charleston, WV 25305-0130

Request for Quotation

RFQ NUMBER
PRI11561

PAGE
3

ADDRESS CORRESPONDENCE TO ATTENTION OF:
TARA LYLE 304-558-2544

VENDOR

*427103343 304-776-5600
 Heritage International Trucks, Inc.
 408 Goff Mountain Road

 Cross Lanes, WV 25313

SHIP TO

WV PRISON INDUSTRIES

 617 LEON SULLIVAN WAY
 CHARLESTON, WV
 25301 304-558-2945

DATE PRINTED	TERMS OF SALE	SHIP VIA	FOB	FREIGHT TERMS
01/09/2012				
BID OPENING DATE: 02/16/2012		BID OPENING TIME 01:30PM		

LINE	QUANTITY	UOP	CAT. NO.	ITEM NUMBER	UNIT PRICE	AMOUNT
<p>A SIGNED BID MUST BE SUBMITTED TO:</p> <p>DEPARTMENT OF ADMINISTRATION PURCHASING DIVISION BUILDING 15 2019 WASHINGTON STREET, EAST CHARLESTON, WV 25305-0130</p> <p>THE BID SHOULD CONTAIN THIS INFORMATION ON THE FACE OF THE ENVELOPE OR THE BID MAY NOT BE CONSIDERED:</p> <p>SEALED BID</p> <p>BUYER: ----- TL/32 -----</p> <p>RFQ. NO.: ----- PRI11561 -----</p> <p>BID OPENING DATE: ----- 2/16/2012 -----</p> <p>BID OPENING TIME: ----- 1:30 PM -----</p> <p>PLEASE PROVIDE A FAX NUMBER IN CASE IT IS NECESSARY TO CONTACT YOU REGARDING YOUR BID:</p> <p>----- 304-204-2606 -----</p> <p>CONTACT PERSON (PLEASE PRINT CLEARLY): Matt Cochran</p> <p>-----</p>						

SEE REVERSE SIDE FOR TERMS AND CONDITIONS			
NATURE	TELEPHONE	DATE	
<i>[Signature]</i>	304-776-5600	2-16-12	
E Sales Manager	FEIN 27-1476356	ADDRESS CHANGES TO BE NOTED ABOVE	
WHEN RESPONDING TO RFQ. INSERT NAME AND ADDRESS IN SPACE ABOVE LABELLED 'VENDOR'			

PRI11561

= Exception

2011 or Newer Delivery Truck

- GVWR 26,000, minimum (Refer to exception Sheet)
- Diesel engine shall be a minimum of 230 hp.
- Exhaust break w/driver controls
- AM/FM radio
- Air conditioned cab
- Transmission to be Allison 2500RDS or equal
- 6-speed automatic transmission (Refer to exception Sheet)
- Front tires 11r22.5g rated 12,350 lbs. Premium highway tread, minimum
- Rear tires 11r22.5g rated 23,000 lbs. Highway traction, minimum (Refer to Exception Sheet)
- Axle ratio 3.90:1 or equal
- Wheelbase no less than 260"
- Nose cone on top of cab
- Dual fuel tanks, minimum 100 gallon total (Refer to exception sheet)
- Dual ac/dc fuel tank heaters with manual switch to change from truck power to 110 ac power when plugged in via power cord (Refer to exception sheet)
- Air brake system
- Rear dust shields (Refer to exception sheet)
- Heated side mirrors
- Truck and body shall be painted white
- Driver seat shall be air suspension, high
- Passenger seat shall be two-man vinyl
- Frame mounted tool box 18"x18"x36", minimum
- On-spot chains mounted
- 24' dry freight van body
- Plywood lined 3/8" full, minimum
- Inside height 96", minimum
- Roll up rear door
- 1-1/8" hardwood floor, minimum
- Threshold steel diamond plate 1/8" x 23"
- Scuff side galvanized steel
- Translucent roof
- Two dome lights
- Two rows e-track each side
- 3300 lb capacity tuc-a-way lift gate with 80" x 48" aluminum platform or equal
- Aluminum body sides
- Fork lift package

- 1/2" plywood liner front, minimum
- Triangle kit & 5# fire extinguishers

Warranty:

All bidders must provide a copy of the manufacturer's warranty

Delivery:

Delivery costs shall be included with your bid. The truck shall be delivered to the agency with 90 days of award of this contract.

Award:

The contract will be awarded to one vendor with the lowest grand total meeting all of the specifications with the most complete bid.

PRI11561 - Bid Form

Bid Form

Item #	Description	Quantity	Unit Price	Extended Amount
1	2011 or newer delivery truck per the specifications	1	\$ 84,447.15	\$ 84,447.15
			GRAND TOTAL:	\$ 84,447.15

Failure to use this form may result in disqualification

Bidder / Vendor Information:

Vendor Name: Heritage International Trucks, Inc.

Contact Name: Matt Cochran

Address: 408 Goff Mountain Road

Cross Lanes, WV 25313

Phone No.: 304-776-5600

Fax No.: 304-204-2606

Email Address: mcochran@heritagetrks.com

Authorized Signature:



RFQ No. PRI11561

STATE OF WEST VIRGINIA
Purchasing Division

PURCHASING AFFIDAVIT

West Virginia Code §5A-3-10a states: No contract or renewal of any contract may be awarded by the state or any of its political subdivisions to any vendor or prospective vendor when the vendor or prospective vendor or a related party to the vendor or prospective vendor is a debtor and the debt owned is an amount greater than one thousand dollars in the aggregate

DEFINITIONS:

"Debt" means any assessment, premium, penalty, fine, tax or other amount of money owed to the state or any of its political subdivisions because of a judgment, fine, permit violation, license assessment, defaulted workers' compensation premium, penalty or other assessment presently delinquent or due and required to be paid to the state or any of its political subdivisions, including any interest or additional penalties accrued thereon.

"Debtor" means any individual, corporation, partnership, association, Limited Liability Company or any other form or business association owing a debt to the state or any of its political subdivisions. "Political subdivision" means any county commission; municipality; county board of education; any instrumentality established by a county or municipality; any separate corporation or instrumentality established by one or more counties or municipalities, as permitted by law; or any public body charged by law with the performance of a government function or whose jurisdiction is coextensive with one or more counties or municipalities. "Related party" means a party, whether an individual, corporation, partnership, association, limited liability company or any other form or business association or other entity whatsoever, related to any vendor by blood, marriage, ownership or contract through which the party has a relationship of ownership or other interest with the vendor so that the party will actually or by effect receive or control a portion of the benefit, profit or other consideration from performance of a vendor contract with the party receiving an amount that meets or exceed five percent of the total contract amount.

EXCEPTION: The prohibition of this section does not apply where a vendor has contested any tax administered pursuant to chapter eleven of this code, workers' compensation premium, permit fee or environmental fee or assessment and the matter has not become final or where the vendor has entered into a payment plan or agreement and the vendor is not in default of any of the provisions of such plan or agreement.

Under penalty of law for false swearing (*West Virginia Code §61-5-3*), it is hereby certified that the vendor affirms and acknowledges the information in this affidavit and is in compliance with the requirements as stated.

WITNESS THE FOLLOWING SIGNATURE

Vendor's Name: Heritage International Trucks, Inc.

Authorized Signature: [Signature] Date: 2-16-12

State of West Virginia

County of Kanawha, to-wit:

Taken, subscribed, and sworn to before me this 16th day of February, 2012.

My Commission expires December 25, 2018.

AFFIX SEAL HERE

NOTARY PUBLIC [Signature]

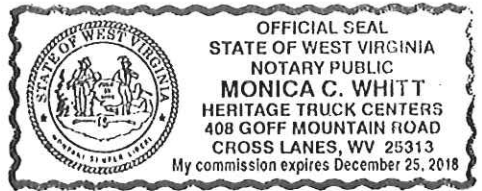

State of West Virginia VENDOR PREFERENCE CERTIFICATE

Certification and application* is hereby made for Preference in accordance with *West Virginia Code*, §5A-3-37. (Does not apply to construction contracts). *West Virginia Code*, §5A-3-37, provides an opportunity for qualifying vendors to request (at the time of bid) preference for their residency status. Such preference is an evaluation method only and will be applied only to the cost bid in accordance with the *West Virginia Code*. This certificate for application is to be used to request such preference. The Purchasing Division will make the determination of the Resident Vendor Preference, if applicable.

1. Application is made for 2.5% resident vendor preference for the reason checked:
 Bidder is an individual resident vendor and has resided continuously in West Virginia for four (4) years immediately preceding the date of this certification; or,
 Bidder is a partnership, association or corporation resident vendor and has maintained its headquarters or principal place of business continuously in West Virginia for four (4) years immediately preceding the date of this certification; or 80% of the ownership interest of Bidder is held by another individual, partnership, association or corporation resident vendor who has maintained its headquarters or principal place of business continuously in West Virginia for four (4) years immediately preceding the date of this certification; or,
 Bidder is a nonresident vendor which has an affiliate or subsidiary which employs a minimum of one hundred state residents and which has maintained its headquarters or principal place of business within West Virginia continuously for the four (4) years immediately preceding the date of this certification; or,
2. Application is made for 2.5% resident vendor preference for the reason checked:
 Bidder is a resident vendor who certifies that, during the life of the contract, on average at least 75% of the employees working on the project being bid are residents of West Virginia who have resided in the state continuously for the two years immediately preceding submission of this bid; or,
3. Application is made for 2.5% resident vendor preference for the reason checked:
 Bidder is a nonresident vendor employing a minimum of one hundred state residents or is a nonresident vendor with an affiliate or subsidiary which maintains its headquarters or principal place of business within West Virginia employing a minimum of one hundred state residents who certifies that, during the life of the contract, on average at least 75% of the employees or Bidder's affiliate's or subsidiary's employees are residents of West Virginia who have resided in the state continuously for the two years immediately preceding submission of this bid; or,
4. Application is made for 5% resident vendor preference for the reason checked:
 Bidder meets either the requirement of both subdivisions (1) and (2) or subdivision (1) and (3) as stated above; or,
5. Application is made for 3.5% resident vendor preference who is a veteran for the reason checked:
 Bidder is an individual resident vendor who is a veteran of the United States armed forces, the reserves or the National Guard and has resided in West Virginia continuously for the four years immediately preceding the date on which the bid is submitted; or,
6. Application is made for 3.5% resident vendor preference who is a veteran for the reason checked:
 Bidder is a resident vendor who is a veteran of the United States armed forces, the reserves or the National Guard, if, for purposes of producing or distributing the commodities or completing the project which is the subject of the vendor's bid and continuously over the entire term of the project, on average at least seventy-five percent of the vendor's employees are residents of West Virginia who have resided in the state continuously for the two immediately preceding years.

Bidder understands if the Secretary of Revenue determines that a Bidder receiving preference has failed to continue to meet the requirements for such preference, the Secretary may order the Director of Purchasing to: (a) reject the bid; or (b) assess a penalty against such Bidder in an amount not to exceed 5% of the bid amount and that such penalty will be paid to the contracting agency or deducted from any unpaid balance on the contract or purchase order.

By submission of this certificate, Bidder agrees to disclose any reasonably requested information to the Purchasing Division and authorizes the Department of Revenue to disclose to the Director of Purchasing appropriate information verifying that Bidder has paid the required business taxes, provided that such information does not contain the amounts of taxes paid nor any other information deemed by the Tax Commissioner to be confidential.

Under penalty of law for false swearing (*West Virginia Code*, §61-5-3), Bidder hereby certifies that this certificate is true and accurate in all respects; and that if a contract is issued to Bidder and if anything contained within this certificate changes during the term of the contract, Bidder will notify the Purchasing Division in writing immediately.

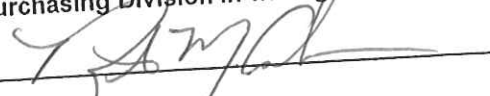
Bidder: Heritage International Trucks, Inc Signed: 
 Date: 2-16-12 Title: Sales Manager

*Check any combination of preference consideration(s) indicated above, which you are entitled to receive.



State of West Virginia
 Department of Administration
 Purchasing Division
 2019 Washington Street East
 Post Office Box 50130
 Charleston, WV 25305-0130

Request for Quotation

RFQ NUMBER
PRI11561

PAGE
1

ADDRESS CORRESPONDENCE TO ATTENTION OF:
TARA LYLE
304-558-2544

VENDOR

*427103343 304-776-5600
 Heritage International Trucks, Inc.
 408 Goff Mountain Road
 Cross Lanes, WV 25313

SHIP TO

WV PRISON INDUSTRIES
 617 LEON SULLIVAN WAY
 CHARLESTON, WV
 25301 304-558-2945

DATE PRINTED	TERMS OF SALE	SHIP VIA	F.O.B.	FREIGHT TERMS
01/31/2012	net			
BID OPENING DATE: 02/16/2012		BID OPENING TIME: 01:30PM		

LINE	QUANTITY	UOP	CAT. NO.	ITEM NUMBER	UNIT PRICE	AMOUNT
001	1	EA		070-53		
ADDENDUM NO. 1 1. QUESTIONS AND ANSWERS ARE ATTACHED. 2. ADDENDUM ACKNOWLEDGEMENT IS ATTACHED. THIS DOCUMENT SHOULD BE SIGNED AND RETURNED WITH YOUR BID. FAILURE TO SIGN AND RETURN MAY RESULT IN DISQUALIFICATION OF YOUR BID. END OF ADDENDUM NO. 1 DELIVERY TRUCK						
***** THIS IS THE END OF RFQ PRI11561 ***** TOTAL:						

SEE REVERSE SIDE FOR TERMS AND CONDITIONS

DATE: 2-16-12 TELEPHONE: 304-776-5600

Sales Manager: *[Signature]* FEIN: 27-1476356

ADDRESS CHANGES TO BE NOTED ABOVE

WHEN RESPONDING TO RFQ, INSERT NAME AND ADDRESS IN SPACE ABOVE LABELED 'VENDOR'

PRI11561
Addendum # 1

QUESTIONS:

Q1: Axle Ratio to be 3.90:1: statement should be corrected to reflect the top miles per hour that you would like the unit to run. Ratios for each engine vary by this selection and maximum engine RPM's assigned to that engine. Thus, road speed will dictate ratio.

A1: 70 miles per hour.

Q2: Wheelbase no less than 260"; Cab to axle dimensions are normally utilized to best meet the body being installed; 24 foot bodies normally require something in the 186" CA range. Wheelbases vary from manufacturer to manufacturer. But the correct CA will be in this range.

A2: 186" CA range is acceptable.

Q3: Dual fuel tanks, minimum 100 gal. total; We suggest adding the verbiage "Aluminum" to this specification. Steel fuel tanks do not weather well in our environment (rust and corrosion) and new low sulphur fuels also take a toll on the inside of the steel tanks over time.

A3: Change the fuel tank specification from steel to aluminum.

Q4: Dual ac/dc fuel tank heaters with manual switch to change from truck power to 110 ac power when plugged in via power cord; we suggest using "Heated Fuel Water Separator" in lieu of the ac/dc fuel tank heater. Winter environment in West Virginia does not require such radical fuel heaters and the change can save the division money on the purchase.

A4: Agency will not change this specification. Our trucks travel the entire state and in the past we have had freezing issues in the Huttonsville, Martinsburg areas as well as other areas of the State. We must have the ac/dc fuel tank heaters.

The bid opening remains 2/16/2012 at 1:30 pm.

No additional questions will be accepted on this RFQ.

EXHIBIT 10

REQUISITION NO.: PRI11561

ADDENDUM ACKNOWLEDGEMENT

I HEREBY ACKNOWLEDGE RECEIPT OF THE FOLLOWING CHECKED
ADDENDUM(S) AND HAVE MADE THE NECESSARY REVISIONS TO MY
PROPOSAL, PLANS AND/OR SPECIFICATION, ETC.

ADDENDUM NO.'S:

NO. 1XXXXXX

NO. 2

NO. 3

NO. 4

NO. 5

I UNDERSTAND THAT FAILURE TO CONFIRM THE RECEIPT OF THE
ADDENDUM(S) MAY BE CAUSE FOR REJECTION OF BIDS. VENDOR
MUST CLEARLY UNDERSTAND THAT ANY VERBAL
REPRESENTATION MADE OR ASSUMED TO BE MADE DURING ANY
ORAL DISCUSSION HELD BETWEEN VENDOR'S REPRESENTATIVES
AND ANY STATE PERSONNEL IS NOT BINDING. ONLY THE
INFORMATION ISSUED IN WRITING AND ADDED TO THE
SPECIFICATIONS BY AN OFFICIAL ADDENDUM IS BINDING.

.....
SIGNATURE

Heritage International Trucks, Inc.
.....
COMPANY

2-16-12
.....
DATE

INTERNATIONAL®

Prepared For:
 West Virginia Prison Industries
 Tara L Lyle
 617 Leon Sullivan Way
 Charleston, WV 25301-1251
 (304)558 - 2945

Presented By:
 HERITAGE INTL TRUCKS INC
 Chuck W Whitlow
 408 GOFF MOUNTAIN ROAD
 CHARLESTON WV 25313 -
 (304)776-5600

Thank you for the opportunity to provide you with the following quotation on a new International truck. I am sure the following detailed specification will meet your operational requirements, and I look forward to serving your business needs.

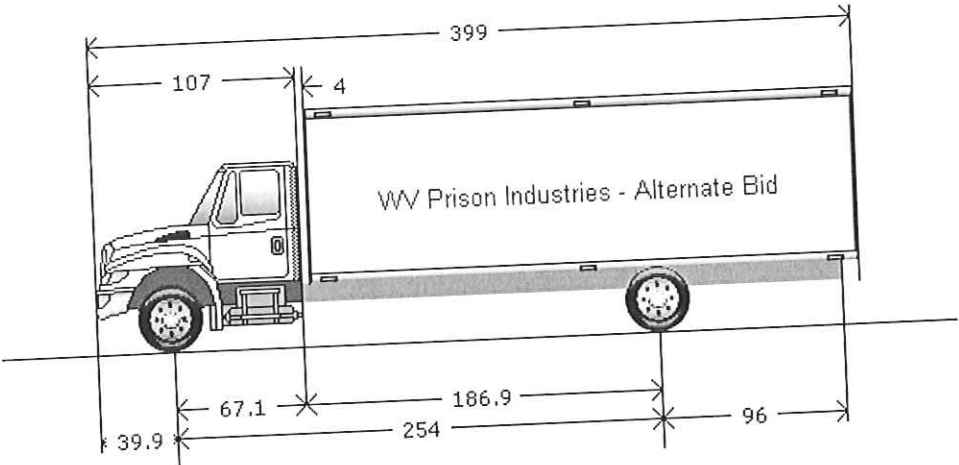

Model Profile
2013 4300 SBA 4X2 (MA025)

- APPLICATION:** Dry Van
- MISSION:** Requested GVWR: 25999. Calc. GVWR: 25999
 Calc. Start / Grade Ability: 23.00% / 2.39% @ 55 MPH
 Calc. Geared Speed: 80.4 MPH
- DIMENSION:** Wheelbase: 254.00, CA: 186.90, Axle to Frame: 96.00
- ENGINE, DIESEL:** {MaxxForce DT} EPA 10, 230 HP @ 2200 RPM, 660 lb-ft Torque @ 1300 RPM, 2400 RPM
 Governed Speed
- TRANSMISSION, AUTOMATIC:** {Allison 2500_RDS_P} 4th Generation Controls; Wide Ratio, 5-Speed, With Overdrive; On/Off Hwy; 33,000 lb GVW & GCW Max., With PTO Provision, Less Retarder
 Omit Item (Clutch & Control)
- CLUTCH:** {Meritor MFS-10-143A} Wide Track, I-Beam Type, 10,000-lb Capacity
- AXLE, FRONT NON-DRIVING:** {Meritor MS-21-14X-4DFR} Single Reduction, 20,000-lb Capacity, R Wheel Ends Gear Ratio: 4.88
- AXLE, REAR, SINGLE:** Conventional
- CAB:** (2) 11R22.5 G661 HSA (GOODYEAR) 497 rev/mile, load range G, 14 ply
- TIRE, FRONT:** (4) 11R22.5 G182 RSD (GOODYEAR) 496 rev/mile, load range H, 16 ply
- TIRE, REAR:** Vari-Rate; 23,500-lb Capacity, With 4500 lb Auxiliary Rubber Spring
- SUSPENSION, RR, SPRING, SINGLE:** Cab schematic 100GA
- PAINT:** Location 1: 9219, Winter White (Std)
 Chassis schematic N/A

INTERNATIONAL®

**Vehicle Specifications
2013 4300 SBA 4X2 (MA025)**

<u>Code</u>	<u>Description</u>
MA02500	Base Chassis, Model 4300 SBA 4X2 with 254.00 Wheelbase, 186.90 CA, and 96.00 Axle to Frame.
1570	TOW HOOK, FRONT (2) Frame Mounted
1CAD	FRAME RAILS High Strength Low Alloy Steel (80,000 PSI Yield); 10.250" x 3.092" x 0.375" (260.4mm x 78.5mm x 9.5mm); 427.0" (10846mm) Maximum OAL
1LEG	LICENSE PLATE HOLDER Includes Upper & Lower Mounting Plate Hardware, Mounted in Existing Holes in Front Bumper
1LLD	BUMPER, FRONT Full Width, Aerodynamic, Steel; 0.142" Material Thickness
	<u>Includes</u> : BUMPER, FRONT Powder Coated Gray (Argent) Color
1SAL	CROSSMEMBER, REAR, AF (01)
1WEJ	WHEELBASE RANGE 199" (505cm) Through and Including 254" (645cm)
2ARX	AXLE, FRONT NON-DRIVING {Meritor MFS-10-143A} Wide Track, I-Beam Type, 10,000-lb Capacity
	<u>Notes</u> : The following features should be considered when calculating Front GAWR: Front Axles; Front Suspension; Brake System; Brakes, Front Air Cam; Wheels; Tires.
3ADB	SUSPENSION, FRONT, SPRING Parabolic, Taper Leaf; 10,000-lb Capacity; With Shock Absorbers
	<u>Includes</u> : SPRING PINS Rubber Bushings, Maintenance-Free
	<u>Notes</u> : The following features should be considered when calculating Front GAWR: Front Axles; Front Suspension; Brake System; Brakes, Front Air Cam; Wheels; Tires.
4091	BRAKE SYSTEM, AIR Dual System for Straight Truck Applications
	<u>Includes</u> : BRAKE LINES Color and Size Coded Nylon : DRAIN VALVE Twist-Type : GAUGE, AIR PRESSURE (2) Air 1 and Air 2 Gauges; Located in Instrument Cluster : PARKING BRAKE CONTROL Yellow Knob, Located on Instrument Panel : PARKING BRAKE VALVE For Truck : QUICK RELEASE VALVE Bendix On Rear Axle for Spring Brake Release: 1 for 4x2, 2 for 6x4 : SLACK ADJUSTERS, FRONT Automatic : SLACK ADJUSTERS, REAR Automatic : SPRING BRAKE MODULATOR VALVE R-7 for 4x2, SR-7 with relay valve for 6x4
	<u>Notes</u> : Front and Rear Dust Shields not Included : Rear Axle is Limited to 19,000-lb GAWR with Code 04091 BRAKE SYSTEM, AIR and Code 04NCL BRAKES, REAR, AIR CAM Regardless of Axle/Suspension Ordered. : Rear Axle is Limited to 20,000-lb GAWR with Code 04091 BRAKE SYSTEM, AIR and Code 04NCG BRAKES, REAR, AIR CAM Regardless of Axle/Suspension Ordered. : Rear Axle is Limited to 23,000-lb GAWR with Code 04091 BRAKE SYSTEM, AIR and Standard Rear Air Cam Brakes Regardless of Axle/Suspension Ordered.
4AZA	AIR BRAKE ABS {Bendix AntiLock Brake System} Full Vehicle Wheel Control System (4-Channel)
4EBS	AIR DRYER {Bendix AD-9} With Heater
	<u>Includes</u> : AIR DRYER LOCATION Inside Left Rail, Back of Cab
4ESX	BRAKE CHAMBERS, FRONT AXLE {Haldex} 20 Sqli

INTERNATIONAL®

Vehicle Specifications
2013 4300 SBA 4X2 (MA025)

<u>Code</u>	<u>Description</u>
4EVL	<p>BRAKE CHAMBERS, REAR AXLE {Haldex GC3030LHDHO} 30/30 Spring Brake</p> <p><u>Includes</u> : BRAKE CHAMBERS, SPRING (2) Rear Parking; WITH TRUCK BRAKES: All 4x2, 4x4; WITH TRACTOR BRAKES: All 4x2, 4x4; 6x4 & 6x6 with Rear Tandem Axles Less Than 46,000-lb. or GVWR Less Than 54,000-lb.</p>
4JCG	<p>BRAKES, FRONT, AIR CAM S-Cam; 15.0" x 4.0"; Includes 20 Sq. In. Long Stroke Brake Chambers</p> <p><u>Notes</u> : Front Axle with 14,000-lb GAWR is Limited to 13,200-lb GAWR when used in Conjunction with 15" BRAKES, FRONT, AIR CAM. : The following features should be considered when calculating Front GAWR: Front Axles; Front Suspension; Brake System; Brakes, Front Air Cam; Wheels; Tires.</p>
4NDB	<p>BRAKES, REAR, AIR CAM S-Cam; 16.5" x 7.0"; Includes 30/30 Sq.In. Long Stroke Brake Chamber and Spring Actuated Parking Brake</p> <p><u>Notes</u> : The following features should be considered when calculating Front GAWR: Front Axles; Front Suspension; Brake System; Brakes, Front Air Cam; Wheels; Tires.</p>
4SBC	AIR COMPRESSOR {Bendix Tu-Flo 550} 13.2 CFM Capacity
5AAA	STEERING COLUMN Stationary
5CAL	STEERING WHEEL 2-Spoke, 18" Diam., Black
5PSM	STEERING GEAR {Sheppard HD94} Power
7BDA	<p>EXHAUST SYSTEM Single, Horizontal, Aftertreatment Device Frame Mounted Right Side Back of Cab, Includes Horizontal Tail Pipe</p> <p><u>Includes</u> : NOTE: The Horizontal Tailpipe Includes a Temperature Control Device</p>
7SCY	ENGINE COMPRESSION BRAKE for MaxxFoRce I6 Engines; Electronically Activated
8000	<p>ELECTRICAL SYSTEM 12-Volt, Standard Equipment</p> <p><u>Includes</u> : BATTERY BOX Steel : DATA LINK CONNECTOR For Vehicle Programming and Diagnostics In Cab : FUSES, ELECTRICAL SAE Blade-Type : HAZARD SWITCH Push On/Push Off, Located on Top of Steering Column Cover : HEADLIGHT DIMMER SWITCH Integral with Turn Signal Lever : HORN, ELECTRIC Single : JUMP START STUD Located on Positive Terminal of Outermost Battery : PARKING LIGHT Integral with Front Turn Signal and Rear Tail Light : STARTER SWITCH Electric, Key Operated : STOP, TURN, TAIL & B/U LIGHTS Dual, Rear, Combination with Reflector : TURN SIGNAL SWITCH Self-Cancelling for Trucks, Manual Cancelling for Tractors, with Lane Change Feature : TURN SIGNALS, FRONT Includes Reflectors and Auxiliary Side Turn Signals, Solid State Flashers; Flush Mounted : WINDSHIELD WIPER SWITCH 2-Speed with Wash and Intermittent Feature (5 Pre-Set Delays), Integral with Turn Signal Lever : WINDSHIELD WIPERS Single Motor, Electric, Cowl Mounted : WIRING, CHASSIS Color Coded and Continuously Numbered</p>
8718	POWER SOURCE Cigar Type Receptacle without Plug and Cord
8GGZ	ALTERNATOR {Leece-Neville LBP2224H} Brush Type; 12 Volt 120 Amp. Capacity, Pad Mount

INTERNATIONAL®

Vehicle Specifications
2013 4300 SBA 4X2 (MA025)

<u>Code</u>	<u>Description</u>
8HAB	BODY BUILDER WIRING Back of Standard Cab at Left Frame or Under Extended or Crew Cab at Left Frame; Includes Sealed Connectors for Tail/Amber Turn/Marker/ Backup/Accessory Power/Ground and Sealed Connector for Stop/Turn
8MKL	BATTERY SYSTEM {International} Maintenance-Free, (3) 12-Volt 1950CCA Total
8RCB	CB RADIO Accommodation Package; Header Mounted; Feeds From Accessory Side of Ignition Switch; Includes Power Source and Two Antenna Bases With Wiring
8RJU	<p><u>Notes</u> : NOT INCLUDED: Antenna</p> <p>RADIO {International} AM/FM Stereo With CD Player, Weatherband, Clock, Auxiliary Input, Includes Multiple Speakers</p> <p><u>Includes</u> : SPEAKERS IN CAB (2) Coaxial with Deluxe Interior : SPEAKERS IN CAB (4) Coaxial with Premium Interior</p>
8WTK	STARTING MOTOR {Delco Remy 38MT Type 300} 12 Volt; less Thermal Over-Crank Protection
8WWJ	INDICATOR, LOW COOLANT LEVEL With Audible Alarm
8WZK	HEADLIGHTS Halogen; Composite Aero Design for Two Light System
9HAD	GRILLE Chrome
9WAC	BUG SCREEN Front End; Mounted Behind Grille
9WAY	FRONT END Tilting, Fiberglass, With Three Piece Construction
10060	PAINT SCHEMATIC, PT-1 Single Color, Design 100
10761	<p><u>Includes</u> : PAINT SCHEMATIC ID LETTERS "GA"</p> <p>PAINT TYPE Base Coat/Clear Coat, 1-2 Tone</p>
10WGD	SPECIAL RATING, GVWR Limited to 25,999-lb GVWR
11001	CLUTCH Omit Item (Clutch & Control)
12959	BLOCK HEATER, ENGINE {Phillips} 120 Volt/1250 Watt
12NUM	<p><u>Includes</u> : BLOCK HEATER SOCKET Receptacle Type; Mounted below Drivers Door</p> <p>ENGINE, DIESEL {MaxxFORCE DT} EPA 10, 230 HP @ 2200 RPM, 660 lb-ft Torque @ 1300 RPM, 2400 RPM Governed Speed</p> <p><u>Includes</u> : AIR COMPRESSOR AIR SUPPLY LINE Naturally-Aspirated (Air Brake Chassis Only) : ANTI-FREEZE Red Shell Rotella Extended Life Coolant; -40 Degrees F/ -40 Degrees C; for MaxxFORCE Engines : COLD STARTING EQUIPMENT Intake Manifold Electric Grid Heater with Engine ECM Control : CRUISE CONTROL Electronic; Controls Integral to Steering Wheel : ENGINE OIL DRAIN PLUG Magnetic : ENGINE SHUTDOWN Electric, Key Operated : FUEL FILTER Included with Fuel/Water Separator : FUEL/WATER SEPARATOR Fuel/Water Separator and Fuel Filter in a Single Assembly; With Water-in-Fuel Sensor; Engine Mounted : GOVERNOR Electronic : OIL FILTER, ENGINE Spin-On Type : WET TYPE CYLINDER SLEEVES</p>

<u>Code</u>	<u>Description</u>
	<u>Notes</u> : Recommend Code 12THT when using front mount obstructions (winches, cones, reels, etc.) that restrict air flow through the radiator.
12TSY	FAN DRIVE {Borg-Warner SA85} Viscous Type, Screw On
	<u>Includes</u> : FAN Nylon
12UAW	RADIATOR Aluminum; 2-Row, Cross Flow, Over Under System, 1045 SqIn Louvered, With 373 SqIn CAC, With In Tank Oil Cooler
	<u>Includes</u> : DEAERATION SYSTEM with Surge Tank : HOSE CLAMPS, RADIATOR HOSES Gates Shrink Band Type; Thermoplastic Coolant Hose Clamps : RADIATOR HOSES Premium, Rubber
12UXG	FEDERAL EMISSIONS for 2010; MaxxFORCE DT Engines
12VBR	AIR CLEANER With Service Protection Element
	<u>Includes</u> : GAUGE, AIR CLEANER RESTRICTION Air Cleaner Mounted
12VXT	THROTTLE, HAND CONTROL Engine Speed Control; Electronic, Stationary, Variable Speed; Mounted on Steering Wheel
12VZA	ENGINE CONTROL, REMOTE MOUNTED Provision for; Includes Wiring for Body Builder Installation of PTO Controls; With Ignition Switch Control for MaxxFORCE post 2007 Emissions Electronic Engines
12WZE	EMISSION COMPLIANCE Federal, Does Not Comply With California Clean Air Regulations
13ALX	TRANSMISSION, AUTOMATIC {Allison 2500_RDS_P} 4th Generation Controls; Wide Ratio, 5-Speed, With Overdrive; On/Off Hwy; 33,000 lb GVW & GCW Max., With PTO Provision, Less Retarder
	<u>Includes</u> : OIL FILTER, TRANSMISSION Mounted on Transmission : TRANSMISSION OIL PAN Magnet in Oil Pan
13WDH	WIRING, TRANS, BODY BUILDER Installed Wiring for Transmission/PTO Controls, for Allison 1000, 2000, 2100, 2200, 2400, 2500 Series Transmission
13WLN	TRANSMISSION OIL Synthetic; 20 thru 28 Pints
13WYK	SHIFT CONTROL PARAMETERS Allison Load Based Shift Schedules (LBSS)
14ANW	AXLE, REAR, SINGLE {Meritor MS-21-14X-4DFR} Single Reduction, 20,000-lb Capacity, R Wheel Ends . Gear Ratio: 4.88
	<u>Includes</u> : REAR AXLE DRAIN PLUG (1) Magnetic, For Single Rear Axle
	<u>Notes</u> : The following features should be considered when calculating Rear GAWR: Rear Axles; Rear Suspension; Brake System; Brakes, Rear Air Cam; Brake Shoes, Rear; Special Rating, GAWR; Wheels; Tires. : When Specifying Axle Ratio, Check Performance Guidelines and TCAPE for Startability and Performance
14VAH	SUSPENSION, RR, SPRING, SINGLE Vari-Rate; 23,500-lb Capacity, With 4500 lb Auxiliary Rubber Spring
	<u>Notes</u> : The following features should be considered when calculating Rear GAWR: Rear Axles; Rear Suspension; Brake System; Brakes, Rear Air Cam; Brake Shoes, Rear; Special Rating, GAWR; Wheels; Tires.
15LKG	FUEL/WATER SEPARATOR With Thermostatic Fuel Temperature Controlled Electric Heater, and Filter Restriction/Change Indicator, Includes Standard Equipment Water-in-Fuel Sensor

February 15, 2012

INTERNATIONAL®

**Vehicle Specifications
2013 4300 SBA 4X2 (MA025)**

<u>Code</u>	<u>Description</u>
15SGH	<p>FUEL TANK Top Draw; D Style, Non Polished Aluminum, 19" Deep, 70 U.S. Gal., 265 L Capacity, With Quick Connect Outlet, Mounted Right Side, Under Cab</p> <p><u>Notes</u> : N/A with 19.5" Tires</p>
16030	<p>CAB Conventional</p> <p><u>Includes</u> : ARM REST (2) Molded Plastic; One Each Door : CLEARANCE/MARKER LIGHTS (5) Flush Mounted : COAT HOOK, CAB Located on Rear Wall, Centered Above Rear Window : CUP HOLDERS Two Cup Holders, Located in Lower Center of Instrument Panel : DOME LIGHT, CAB Rectangular, Door Activated and Push On-Off at Light Lens, Timed Theater Dimming, Integral to Console, Center Mounted : GLASS, ALL WINDOWS Tinted : GRAB HANDLE, CAB INTERIOR (1) "A" Pillar Mounted, Passenger Side : GRAB HANDLE, CAB INTERIOR (2) Front of "B" Pillar Mounted, One Each Side : INTERIOR SHEET METAL Upper Door (Above Window Ledge) Painted Exterior Color</p>
16HBA	<p>GAUGE CLUSTER English With English Electronic Speedometer</p> <p><u>Includes</u> : GAUGE CLUSTER (5) Engine Oil Pressure (Electronic), Water Temperature (Electronic), Fuel (Electronic), Tachometer (Electronic), Voltmeter : ODOMETER DISPLAY, Miles, Trip Miles, Engine Hours, Trip Hours, Fault Code Readout : WARNING SYSTEM Low Fuel, Low Oil Pressure, High Engine Coolant Temp, and Low Battery Voltage (Visual and Audible)</p>
16HGH	<p>GAUGE, OIL TEMP, ALLISON TRAN</p>
16HKT	<p>IP CLUSTER DISPLAY On Board Diagnostics Display of Fault Codes in Gauge Cluster</p>
16JNT	<p>SEAT, DRIVER {National 2000} Air Suspension, High Back With Integral Headrest, Vinyl, Isolator, 1 Chamber Lumbar, With 2 Position Front Cushion Adjust, -3 to +14 Degree Angle Back Adjust</p>
16PHJ	<p><u>Includes</u> : SEAT BELT 3-Point, Lap and Shoulder Belt Type</p> <p>SEAT, TWO-MAN PASSENGER {Gra-Mag} Fixed Back, Two Integral Headrest, Vinyl, Less Under Seat Storage Compartment</p>
16SDL	<p><u>Includes</u> : SEAT BELT (2) One 3-Point Shoulder Belt and One 2-Point Lap Belt (Center Position)</p> <p>MIRRORS (2) {Lang Mekra} Rectangular, 7.44" x 14.84" & 7.44" sq. Convex Both Sides, 102" Inside Spacing, Breakaway Type, Heated Heads Thermostatic Controlled, Black Heads, Brackets and Arms</p>
16VHG	<p>CAB MOUNTING HEIGHT EFFECTS Mid Cab in Lieu of Low Cab Mounting Height (Approx. 4") With Cab Air Suspension</p>
16WBY	<p>ARM REST, RIGHT, DRIVER SEAT</p>
16WCT	<p>AIR CONDITIONER {Blend-Air} With Integral Heater & Defroster</p> <p><u>Includes</u> : HEATER HOSES Premium : HOSE CLAMPS, HEATER HOSE Mubea Constant Tension Clamps : REFRIGERANT Hydrofluorocarbon HFC-134A</p>
16WJS	<p>INSTRUMENT PANEL Center Section, Flat Panel</p>
16WKY	<p>HVAC FRESH AIR FILTER</p>
16WRX	<p>CAB INTERIOR TRIM Deluxe</p>

Inventory Vehicle

6

Proposal: 1944-01

INTERNATIONAL®

Vehicle Specifications
2013 4300 SBA 4X2 (MA025)

<u>Code</u>	<u>Description</u>
	<p><u>Includes</u></p> <ul style="list-style-type: none"> : "A" PILLAR COVER Molded Plastic : CAB INTERIOR TRIM PANELS Cloth Covered Molded Plastic, Full Height; All Exposed Interior Sheet Metal is Covered Except for the Following: with a Two-Man Passenger Seat or with a Full Bench Seat the Back Panel is Completely Void of Covering : CONSOLE, OVERHEAD Molded Plastic; With Dual Storage Pockets with Retainer Nets and CB Radio Pocket : DOOR TRIM PANELS Molded Plastic; Driver and Passenger Doors : FLOOR COVERING Rubber, Black : HEADLINER Soft Padded Cloth : INSTRUMENT PANEL TRIM Molded Plastic with Black Center Section : STORAGE POCKET, DOOR (1) Molded Plastic, Full-Length; Driver Door : SUN VISOR (2) Padded Vinyl with Driver Side Toll Ticket Strap, Integral to Console
16WSK	CAB REAR SUSPENSION Air Bag Type
27DMA	<p>WHEELS, FRONT DISC; 22.5" Painted Steel, 2 Hand Hole, 10 Stud (285.75MM BC) Hub Piloted, Flanged Nut, Metric Mount, 8.25 DC Rims; With Steel Hubs</p> <p><u>Includes</u></p> <ul style="list-style-type: none"> : PAINT IDENTITY, FRONT WHEELS White <p><u>Notes</u></p> <ul style="list-style-type: none"> : Compatible Tire Sizes: 11R22.5, 12R22.5, 255/70R22.5, 255/80R22.5, 265/75R22.5, 275/70R22.5, 275/80R22.5, 295/75R22.5, 295/80R22,5
28DMA	<p>WHEELS, REAR DUAL DISC; 22.5" Painted Steel, 2 Hand Hole, 10-Stud (285.75MM BC) Hub Piloted, Flanged Nut, Metric Mount, 8.25 DC Rims; With Steel Hubs</p> <p><u>Includes</u></p> <ul style="list-style-type: none"> : PAINT IDENTITY, REAR WHEELS White <p><u>Notes</u></p> <ul style="list-style-type: none"> : Compatible Tire Sizes: 11R22.5, 12R22.5, 255/70R22.5, 255/80R22.5, 265/75R22.5, 275/70R22.5, 275/80R22.5, 295/75R22.5, 295/80R22,5
7372138107	(2) TIRE, FRONT 11R22.5 G661 HSA (GOODYEAR) 497 rev/mile, load range G, 14 ply
7382130121	(4) TIRE, REAR 11R22.5 G182 RSD (GOODYEAR) 496 rev/mile, load range H, 16 ply
1	US Truck Body - 24' Dry Van with 3300# Aluminum Lift Gate to meet spec
	Raw Materials Surcharge



February 16, 2016

Exceptions to RFQ PRI11561- Alternate Bid

The following is listed on your specification sheet:

-GVWR 26,000, minimum

We are quoting stock unit on the ground for quick body installation and delivery. Unit has 10,000 lb. front axle and 20,000 lb. rear axle with 23,500 lb. rear springs with 4,500 lb. auxiliary. It is de-rated to 25,999 lb. GVWR.

-6-Speed automatic transmission

Transmission is Allison 2500RDS, but is 5 speed model

-Rear tires exceed "g" rating by offering higher "h" rating

-Dual fuel tanks, minimum 100 gallon total

Truck being quoted has 70 gallon single fuel tank

-Dual ac/dc fuel tank heaters with manual switch to change from truck power to 110ac power then plugged in via power cord

We do not offer this specification. In reviewing two other very large West Virginia State Agencies operating diesel engine power, they do not use this in any application. The State of West Virginia Department of Highways operates units all over the 55 counties of our state and do not use fuel tank heaters (including the Martinsburg and Huttonsville areas). In addition, the State of West Virginia Department of Education bid specifications, covering all 55 counties, also do not require such a device.

-Rear Dust Shields

Truck being quoted does not have Rear Dust Shields

Heritage International Trucks, Inc. provides the following two cold weather engine devices that will meet the needs of your operation: 12V – 1000 watt 115V ac block heater and a heated fuel water separator as part of this bid in lieu of the specification in the bid.

-The truck shall be delivered to the agency with(in) 90 days of award of contract

Current production lead times plus the installation of the van body and On Spot Chains will place us at the 135 day mark on delivery.

We thank you for this opportunity.



1807 N. Bloomington St.
 Streator, IL 61364
 Ph: 815-672-3211 or 800-443-0843
 Fax: 815-672-1490
sales@ustruckbody.com

Heritage International Trucks, Inc.
 1714 Robert C. Byrd Drive
 Beckley, WV 25801
cwhitlow@heritagetruck.com
 Attn: Chuck Whitlow
 Quantity: 1 / Re: PRI11561

Date: 1/26/2012 revised
 Quote #: MD27311
 Model: VA 24 96 96
 Phone: (888) 502 7846
 Fax: (304) 253 2697

ALUMINUM VAN BODY QUOTATION

LENGTH: 24' I.D. WIDTH: 96" O.D. HEIGHT: 96" I.D.

Construction:	(.040) Pre-painted white aluminum panels with high strength extruded aluminum (not steel) "Z" posts on 16" centers. Seven front wall posts (not five) for added strength and durability. Extruded aluminum front corner radius posts, (not roll formed) for maximum strength.
Roof:	(.060) translucent roof panel with anti-sag roof bows on 24" centers, "Zephyr" 12" fuel saving roof radius design with heavy-duty cast aluminum (not plastic) corner castings.
Rear Frame:	11 Ga. Galvaneal steel, internally and externally reinforced, and gusseted at all stress points, painted to match.
Side Door(s):	None.
Rear Door:	Standard plastic covered 3/4" plywood roll up, 88" wide x 90.5" high clear opening. Stainless steel rivets and "E" coated hardware.
Rear:	Interlift ILP-33 tuck under liftgate, 3300 lb. capacity 80" x 48" aluminum platform, level ride operation, HD 2 step dock bumper with rubber blocks, cab cut off switch.
Grab Handle(s):	Curb side and road side on rear frame.
Rear Lighting:	Utilize OEM tail lights.
Floor:	1-1/8" high quality domestic laminated hardwood. 24" x 1/8" steel threshold plate at rear, with front edge routed into flooring.
Cross members:	3" steel I-Beam cross members on 12" centers with full steel wheel pan support over wheel area.
Interior Sides:	Sides - 3/8" full height premium plywood.
Interior Front:	Front - 1/2" full height premium plywood.
Interior Ties:	Sides - Two (2) row(s) recessed "E" Track @ ___ & ___ " on center. Front - None.

MD27311 / PAGE 2

Scuff Plate:	Sides - 12" x 14 Ga. galvanized steel. Front - 12" x 12 Ga. galvanized steel extending below floor, welded to front understructure for maximum front wall strength.
Lights:	Interior - Two (2) dome light(s) with switch at rear, inside door on curbside. <i>Note: When switch is supplied by chassis OEM, dome light will be wired to factory switch in cab.</i> Exterior - per FMVSS - 108 with reflectors.
Undercoating:	Petroleum base undercoating applied, (not paint) full understructure.
Mounting:	Hardwood isolator with 5/8" zinc plated U-bolts installed through custom cut steel crush pipes between chassis frame. Structural steel channel anti-shift "side standards" welded to structural steel long sills. Complete factory mounting on drop shipped chassis with "U.S. Truck Body" or customer supplied mud flaps.
Understructure:	Unless noted below in ADDITIONAL FEATURES , this body is quoted and built for a single axle chassis. Tandem axle chassis require the <i>additional cost option</i> for our Tandem Axle Reinforcement Package .

ADDITIONAL FEATURES INCLUDED IN THE ABOVE PRICING:

1. Four additional cross members at rear on 6" centers.
2. One 5# ABC fire extinguisher and triangle kit placed in box in cab.
3. Nose Cone installed.
4. 36" long x 18" high x 24" deep 11 Ga. galvaneal steel under body tool box with locking handle, installed on road side close to cab.

TERMS: Net 20 Days. This quotation is firm for a 30 day period, subject to change without notification beyond 30 days. Any applicable state tax, or Federal Excise Tax on bodies mounted on chassis exceeding 33,000 lbs. GVW is not included and will be added as applicable. I have read and approve the above quotation and terms and indicated options that I want included into the base pricing. I authorize U.S. Truck Body to complete the above work at the price as illustrated. Note: Transportation charges when included herein for other than F.O.B. Streator, IL are subject to fluctuation up or down based upon the then current fuel surcharge in effect as applied by the carrier and will be adjusted accordingly due to fuel price volatility.

Customer Signature of Acceptance to Proceed With Order: x _____
 Purchase Order #: _____ Date of Acceptance: _____
 E.T.A. of Chassis to Streator, IL: _____ Last Eight of V.I.N: _____
 Year / Make / Model of Chassis: _____
 Suspension Type (Circle One): Air Ride Spring Tire Size: _____
 Wheelbase: _____ Cab to Axle: _____

28 REASONS TO CHOOSE

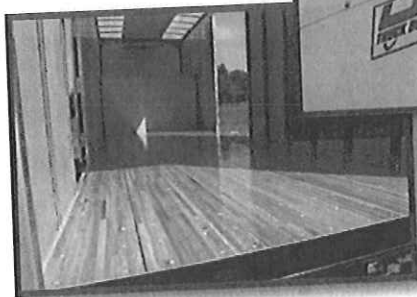
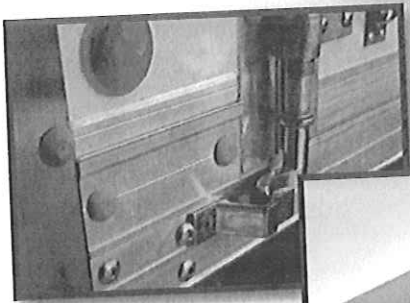

Since 1945, U.S. TRUCK BODY has been providing the transportation industry with high quality van bodies. There are many reasons to choose U.S. TRUCK BODY over our competition, but here we are going to present just 28. Let us show you how our bodies will add value to your operation. Give us a shot to quote your next van body purchase.

1-800-443-0843 • www.ustruckbody.com • sales@ustruckbody.com

WHY U.S. TRUCK BODY IS THE BEST IN CLASS VAN BODY BUILDER

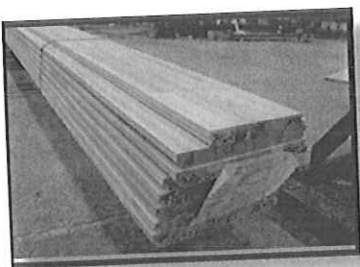
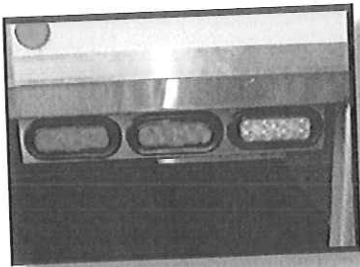
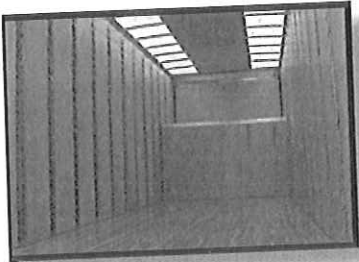
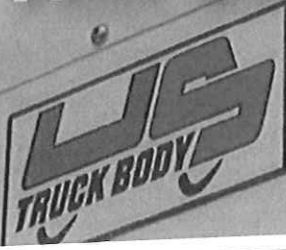

1. Front corner radius is constructed of 1/8" aluminum extrusion (not roll formed).
2. Aluminum model has seven posts (not five) on front wall for maximum strength.
3. Shortest lead times in the industry.
4. Flooring is high quality domestic laminated hardwood (not pine or Malaysian).
5. Aluminum model has solid rivet spacing on 2.5" centers on every (not every other) seam.
6. Front corner castings are heavy duty aluminum (not plastic or composite) for longer life.
7. Decades and decades of experienced staff to assist with every van body specification and application.
8. DuraPlate panel (not plymetal) construction on all side and rear swing doors.
9. Fastest turn around on quotes in the industry.
10. Front wall scuff plate extends below floor welded to understructure.
11. Premium stainless steel (not zinc coated) bar lock hardware on rear swing doors.
12. Red and white LED lamps are standard with tail lights in rear frame option.
13. Dock bumpers are steel reinforced (not wood filled) with standard rubber bumpers.
14. Longitudinals are gusseted to every (not alternating) cross member.
15. Standard model roll up door has E coated hardware and stainless steel rivets.
16. Steel crush pipes installed on U bolts to prevent chassis frame damage.
17. Hardwood filler boards are steel banded to frame rails for no movement.
18. Front 10" roof radius designed for maximum air flow & fuel efficiency.
19. Tapered (not a trough) rear threshold prevents rot and water seepage from bumper.
20. Stainless steel rear frame is standard on all rear swing door equipped bodies.
21. Undercoating is heavy petroleum based (not just paint) on full understructure.
22. Exclusive underbody handles are standard equipment on all side doors.
23. Heavy duty extruded aluminum hinges on all swing doors.
24. Only stainless steel bolts, screws and aluminum fasteners used in construction.
25. All wiring is enclosed in plastic loom to protect against contact wear.
26. Pre-build available of some models pending chassis arrival.
27. No extra charge for translucent roof panel in lieu of aluminum panel.
28. Two 5/16" (not 1/4" or smaller) screws per board into flooring at every crossmember.



U.S. Truck Body • 1807 North Bloomington St. • Streator, IL 61364
Ph: 800-4430-0843 • 815-672-3211 • Fx: 815-672-1490
E-mail: sales@ustruckbody.com • Web: www.ustruckbody.com



U.S. TRUCK BODY 5-YEAR LIMITED WARRANTY

U.S. Truck Body warrants its FRP, aluminum and Freight Plate bodies, to the original purchaser, to be free from defects in material and workmanship for five (5) years from the date of delivery. Warranted for one year from date of delivery, are wood flooring, exterior paints and other finishes, wiring installation, caulking and protection against water leaks. Products and parts which are sold by U.S. Truck Body but not manufactured by U.S. Truck Body are not warranted by U.S. Truck Body, but are sold only with the warranties, if any, of the applicable manufacturer thereof. U.S. Truck Body hereby assigns to Purchasers, to the extent assignable, the applicable manufacturer's warranty for such products not manufactured by U.S. Truck Body. This Limited Warranty does not cover any problems that result from U.S. Truck Body bodies being subject to "Abnormal Usage". By "Abnormal Usage" U.S. Truck Body means that the body is used in the manner and for the purposes which the applicable body is not intended to be used. This Limited Warranty does not cover damage, without limitation, resulting from corrosive, hazardous or inherently unsafe cargo; or minor imperfections or defects which do not generally impair or affect the fair market value of the body or its suitability for its intended use; or damage or defects attributable to normal wear and usage.

Specifically excluded, without limitation are any and all warranties of merchantability and of fitness for a particular purpose. U.S. Truck Body shall not be liable for any amount in excess of the truck body purchase price, and in no event for special, indirect, consequential or incidental damages arising out of, or in connection with this warranty or the U.S. Truck Body bodies hereunder. No party shall make any repair under this warranty without the prior written consent of U.S. Truck Body. If U.S. Truck Body requests it, purchaser at its cost shall deliver the defective truck body to U.S. Truck Body or its designee for repairs.

Any claim under this warranty must be made within thirty (30) days from the date such claim should reasonably been discovered. Timeliness of notification being of the essence, Purchaser's late notification relieves U.S. Truck Body of all liability hereunder.

28 REASONS TO CHOOSE

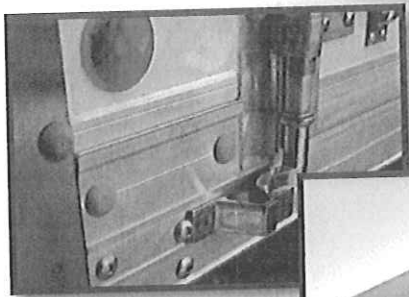

Since 1945, U.S. TRUCK BODY has been providing the transportation industry with high quality van bodies. There are many reasons to choose U.S. TRUCK BODY over our competition, but here we are going to present just 28. Let us show you how our bodies will add value to your operation. Give us a shot to quote your next van body purchase.

WHY U.S. TRUCK BODY IS THE BEST IN CLASS VAN BODY BUILDER

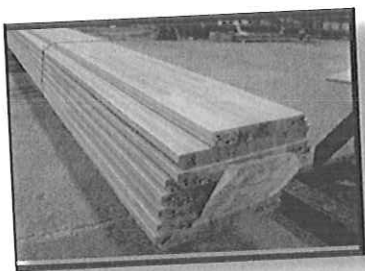
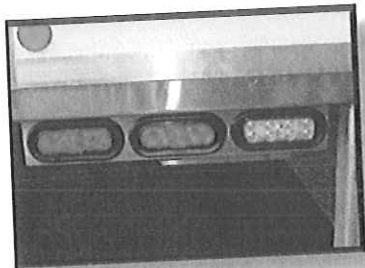
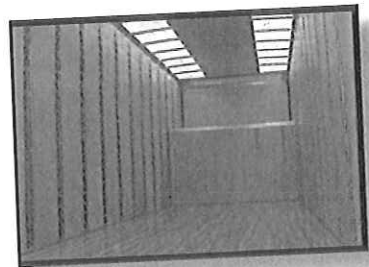
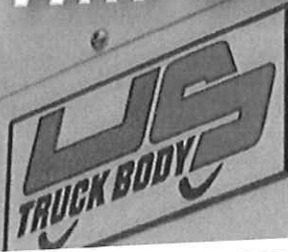

1. Front corner radius is constructed of 1/8" aluminum extrusion (not roll formed).
2. Aluminum model has seven posts (not five) on front wall for maximum strength.
3. Shortest lead times in the industry.
4. Flooring is high quality domestic laminated hardwood (not pine or Malaysian).
5. Aluminum model has solid rivet spacing on 2.5" centers on every (not every other) seam.
6. Front corner castings are heavy duty aluminum (not plastic or composite) for longer life.
7. Decades and decades of experienced staff to assist with every van body specification and application.
8. DuraPlate panel (not plymetal) construction on all side and rear swing doors.
9. Fastest turn around on quotes in the industry.
10. Front wall scuff plate extends below floor welded to understructure.
11. Premium stainless steel (not zinc coated) bar lock hardware on rear swing doors.
12. Red and white LED lamps are standard with tail lights in rear frame option.
13. Dock bumpers are steel reinforced (not wood filled) with standard rubber bumpers.
14. Longitudinals are gusseted to every (not alternating) cross member.
15. Standard model roll up door has E coated hardware and stainless steel rivets.
16. Steel crush pipes installed on U bolts to prevent chassis frame damage.
17. Hardwood filler boards are steel banded to frame rails for no movement.
18. Front 10" roof radius designed for maximum air flow & fuel efficiency.
19. Tapered (not a trough) rear threshold prevents rot and water seepage from bumper.
20. Stainless steel rear frame is standard on all rear swing door equipped bodies.
21. Undercoating is heavy petroleum based (not just paint) on full understructure.
22. Exclusive underbody handles are standard equipment on all side doors.
23. Heavy duty extruded aluminum hinges on all swing doors.
24. Only stainless steel bolts, screws and aluminum fasteners used in construction.
25. All wiring is enclosed in plastic loom to protect against contact wear.
26. Pre-build available of some models pending chassis arrival.
27. No extra charge for translucent roof panel in lieu of aluminum panel.
28. Two 5/16" (not 1/4" or smaller) screws per board into flooring at every crossmember.

U.S. Truck Body • 1807 North Bloomington St. • Streator, IL 61364
Ph: 800-4430-0843 • 815-672-3211 • Fx: 815-672-1490
E-mail: sales@ustruckbody.com • Web: www.ustruckbody.com

ILP PALLET PRO

2500 and 3300 lbs. Capacity

MBB PALFINGER

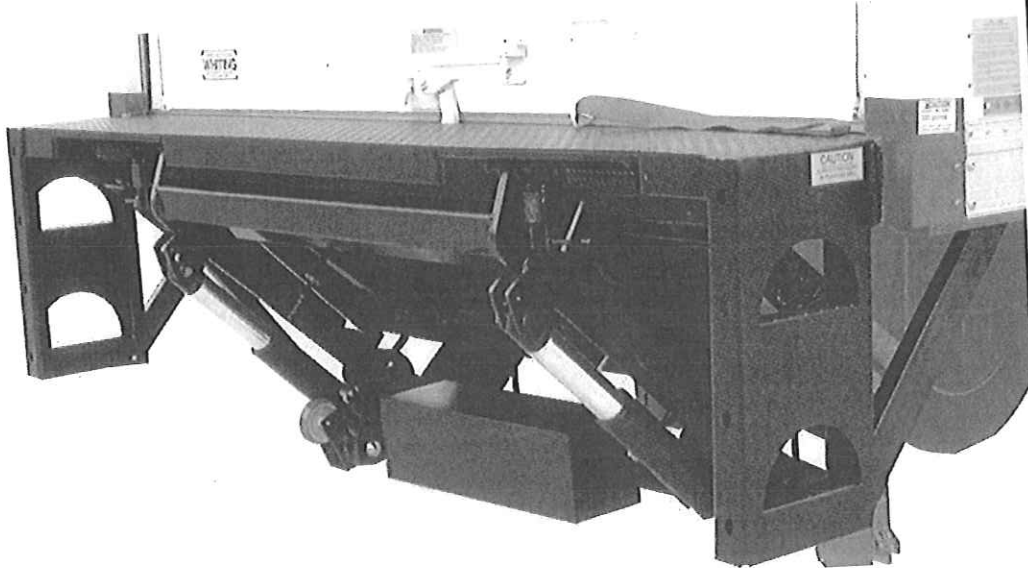

—OPTIMIZED—
FLEXIBILITY
DURABILITY
PROFITABILITY

The ILP Pallet Pro provides a lot of value for a small premium. Level ride platforms available in a variety of sizes from 48", 54", 60" x 80". Units are available in several steel and aluminum combinations.
LARGE Platform Lift! SMALL Platform Price!

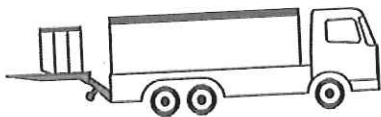

HEAVY DUTY CONSTRUCTION

- Bushings & zerks at all pivot points
- Heat treated pins
- Wide lift arm:
 - Provides added stability
 - Accepts a fixed hitch
- Thermo protected powerpack
- Increases life of components
- 150 AMP circuit breaker

BUILT IN STANDARD/ SAFETY FEATURES

- Dual cylinder stability
- Cab shut off switch
- Hydraulic cylinder locks on cylinder ports
- Adjustable roller and dual torsion assist offer minimum effort for platform folding
- Level ride platform
- Wide bed height range:
 - The 48" platform unit can be installed on as low as 38" laden bed height/up to 53" unladen

The MBB PALFINGER Pallet Pro, offering a platform size, level ride and lift capacity to handle many palletized or carted freight safely at a budget price.

MBB PALFINGER liftgates are pre-filled with aerospace hydraulic fluid. Our standard hydraulic cylinder lock provides added stability, better user control and improved safety.

The two cylinder mid arm design can accommodate a fixed receiver hitch. The platform rotates on an adjustable roller to adapt for different bed height installations.

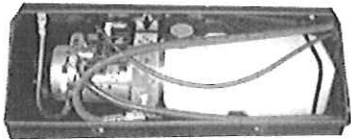

The thermo protected PowerPack is fully enclosed in a H/D powder coated steel box for protection and easy inspection. By using over sized quality components, we minimize maintenance and downtime.



The ILP incorporates our double torsions on both the main and folded section. The unique leveling joint on the ILP does not rotate on the ground. This makes the ILP an exceptionally smooth operating lift.

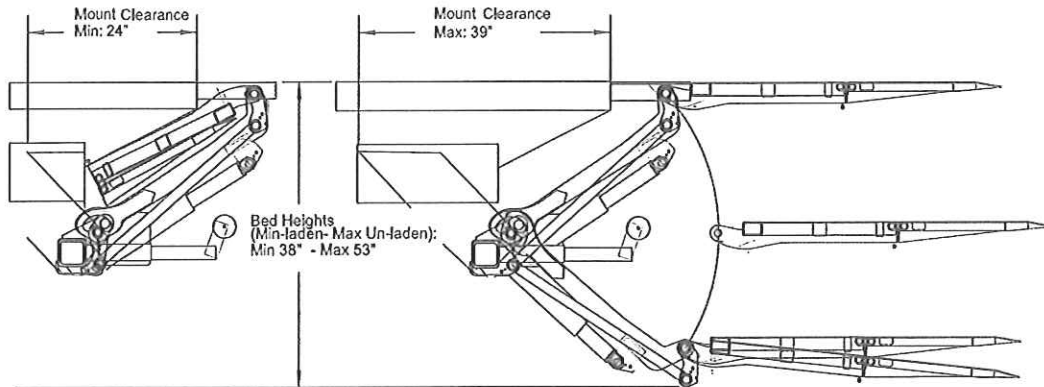

LIFTGATE OPTIONS:

- ❑ Auxillary truck and trailer kits
- ❑ Dock bumpers
- ❑ Rubber pads
- ❑ Cart stops
- ❑ DOT rear impact guard
- ❑ Extra heavy duty trailer dock bumpers
- ❑ Hand held remote
- ❑ Aluminum tip sections
- ❑ All aluminum platforms
- ❑ Wireless remote
- ❑ 2" Receiver hitch

Model	Lifting Capacity (lbs)	Platform Length (inches)	Platform Width (inches)	Bed Height (inches)	Approx. Weight (lbs)	Mount Clearance (inches)
ILP 25	2500	48	80	38 - 53	750	21 - 30
ILP 33	3300	48	80	38 - 53	840	21 - 30
ILP 33	3300	54	80	45 - 55	900	24 - 34
ILP 33	3300	60	80	45 - 55	930	24 - 34

**LIMITED WARRANTY FOR MODELS
1000, 4000, DURASTAR ® SERIES**

*Effective with vehicles built July 12, 2011 or later.

BASIC VEHICLE

Navistar, Inc., at its option, will repair or replace any part of this vehicle which proves defective in material or workmanship, in normal use and service, with new or ReNEWcod® parts, based on the Component Coverage's below. Exceptions are listed below:

BASIC VEHICLE COVERAGE	Months	Miles
Basic Vehicle Warranty (Feature Code 40024) (See exceptions listed below)	24	Unlimited
*Note-Items not listed in warranty exceptions follow base warranty		
Warranty Exceptions		
CHASSIS COVERAGE	Months	Miles
Frame side rails	84	Unlimited
Cab/cowl structure	60	Unlimited
Cab/cowl perforation corrosion	60	Unlimited
ENGINE COVERAGE	Months	Miles
Non-Rescue Applications		
MaxxForce® 7 Engine (Includes DPF)	36	150/240
MaxxForce® 9 Engine (Includes DPF)	36	150/240
MaxxForce® DT Engine (Includes DPF)	36	150/240
MaxxForce® 7 Engine glow plugs, relay, harness/connector (07 ERA)	12	Unlimited
Rescue Application Only (Fire Truck, Ambulance, Emergency)		
MaxxForce® 7 Engine (Includes DPF)	60	100/160
MaxxForce® 9 Engine (Includes DPF)	60	100/160
MaxxForce® DT Engine (Includes DPF)	60	100/160
MaxxForce® 7 Engine glow plugs, relay, harness/connector (07 ERA)	36	Unlimited
DRIVETRAIN		
Meritor Axles (DuraStar model)	36	Unlimited
MISCELLANEOUS COVERAGE	Months	Miles
Batteries	12	Unlimited
Brightwork, Chassis Paint and Corrosion (other than Cab)	6	Unlimited
Hood/Cab Paint	12	Unlimited
FIRST 90 DAYS FROM DELIVERY TO USER (DTU)		
Correction of loose fasteners, squeaks, rattles and unusual noises		
Towing (Unless specific stated coverage above)		
Adjustments and Maintenance (e.g. aim headlights, adjust brakes/clutch, adjust steering system, check and fill coolant levels.		

WHAT IS NOT INCLUDED UNDER BASIC COVERAGE

- **COMPONENTS / ITEMS:**
 - Warranted by their respective manufacturers (e.g., non-Navistar brand engines, tires, Allison Transmissions, Eaton Hybrid components, lubricants, etc.)
 - Bodies, equipment, and accessories installed by other than authorized Navistar Truck employees at Navistar Truck manufacturing plants.
 - Front and rear axle alignment.
- **REPAIRS & MAINTENANCE:**
 - Maintenance-related items/repairs, or those as a result of normal wear and tear, including tune-ups, brake/clutch linings, windshield wiper blades, tire balancing, lubrication and other similar procedures/parts required to keep vehicle in good working condition.
 - Failures that are the result of poor fuel quality, water in fuel, rust, etc.
 - Vehicle misuse, negligent care, improper maintenance, improper operation, or the result of accident or collision.
 - Fade, runs, mismatch or damage to paint, trim items, upholstery, chrome, polished surfaces, etc., resulting from environmental causes, improper polishes, cleaners or washing solutions, or chemical and industrial fallout.
 - Failure to observe published capacity or load specifications for engine, transmission, propshaft, axes (power train) and suspension.
- **OTHER:**
 - Vehicles sold and/or operated outside the United States and Canada.
 - Vehicles/components which have had unauthorized alterations or modifications.
 - Vehicles on which the odometer reading has been altered.
 - Loss of time or use of the vehicle, loss of profits, inconvenience, or other consequential or incidental damages or expenses.
 - Replacement of defective parts with parts other than those provided by Navistar, Inc.

OBTAINING SERVICE

Return this vehicle to any International Truck Dealer authorized to service this model vehicle and engine.

This warranty is automatically transferred to subsequent owners at no charge. Visit your local Authorized International Truck Dealer for name and address change information.

Note: The customer has 365 days and up to a maximum of 100,000 miles (160,000 km) from DTU (delivery to end user) to purchase an extended warranty on the unit. For extended warranty purchases between 181 through 365 days from DTU and <100,000 miles (160,000 km) an additional fee will be assessed. See your local International dealer for details.

DISCLAIMER

NO WARRANTIES ARE GIVEN BEYOND THOSE DESCRIBED HEREIN. THIS WARRANTY IS IN LIEU OF ALL OTHER WARRANTIES, EXPRESSED OR IMPLIED. THE COMPANY SPECIFICALLY DISCLAIMS WARRANTIES OF MERCHANTABILITY AND FITNESS FOR A PARTICULAR PURPOSE. ALL OTHER REPRESENTATIONS TO THE USER/PURCHASER, AND ALL OTHER OBLIGATIONS OR LIABILITIES, THE COMPANY FURTHER EXCLUDES LIABILITY FOR INCIDENTAL AND CONSEQUENTIAL DAMAGES, ON THE PART OF THE COMPANY OR SELLER. No person is authorized to give any other warranties or to assume any liabilities on the Company's behalf unless made or assumed in writing by the Company; and no other person is authorized to give any warranties or to assume any liabilities on the seller's behalf unless made or assumed in writing by the seller.

Remedies Under State or Provincial Law: Some States and Provinces do not allow the exclusion or limitation of incidental or consequential damages, so the above limitation or exclusion may not apply to the owner. This warranty gives the owner specific legal rights, and he may also have other legal rights which may vary by state or province.

RECORD OF OWNERSHIP

Upon receipt of new vehicle by original owner, complete the following:
I have read this Warranty Brochure and fully understand the warranty coverage. I acknowledge that I have received a copy of the Owner's Limited Warranty and I accept the terms described herein.

Customer Signature	_____	Date	_____
Owner's Address	_____	City	_____
Truck Model	_____	State/Prov	_____
Engine Number	_____	Postal Code	_____
Date Delivered to User (DTU)	_____	Vehicle Identification Number	_____
	_____	Engine Serial Number	_____
	_____	Odometer Reading at Delivery	_____

IMPORTANT: The information contained in this Warranty Policy explains the coverage provided on your new Navistar vehicle. This policy should be kept in the vehicle for presentation to the Dealer when you request warranty services.