



State of West Virginia
 Department of Administration
 Purchasing Division
 2019 Washington Street East
 Post Office Box 50130
 Charleston, WV 25305-0130

Request for Quotation

RFQ NUMBER
PRI10863

PAGE
1

ADDRESS CORRESPONDENCE TO ATTENTION OF:
TARA LYLE 304-558-2544

VENDOR

RFQ COPY
 TYPE NAME/ADDRESS HERE
 Worldwide Equipment of WV
 Charleston Division
 PO Box 8557
 South Charleston WV 25303

SHIP TO

WV PRISON INDUSTRIES
 617 LEON SULLIVAN WAY
 CHARLESTON, WV
 25301 304-558-2945

DATE PRINTED	TERMS OF SALE	SHIP VIA	F.O.B.	FREIGHT TERMS
07/28/2011				

BID OPENING DATE: 08/31/2011 BID OPENING TIME 01:30PM

LINE	QUANTITY	UOP	CAT. NO.	ITEM NUMBER	UNIT PRICE	AMOUNT
0001	1	EA		070-53	81,106. ⁰⁰	81,106. ⁰⁰
DELIVERY TRUCK THE WEST VIRGINIA PURCHASING DIVISION FOR THE AGENCY, WEST VIRGINIA CORRECTIONAL INDUSTRIES, IS SOLICITING BIDS FOR ONE (1) 2011 OR NEWER DELIVERY TRUCK, PER THE ATTACHED SPECIFICATIONS. INQUIRIES: WRITTEN QUESTIONS WILL BE ACCEPTED UNTIL CLOSE OF BUSINESS ON 08/15/2011. QUESTIONS MAY BE SENT VIA USPS, FAX, COURIER OR E-MAIL. IN ORDER TO ASSURE NO VENDOR RECEIVES AN UNFAIR ADVANTAGE, NO SUBSTANTIVE QUESTIONS WILL BE ANSWERED ORALLY. IF POSSIBLE, E-MAIL QUESTIONS ARE PREFERRED. ADDRESS INQUIRIES TO: TARA LYLE DEPARTMENT OF ADMINISTRATION PURCHASING DIVISION 2019 WASHINGTON STREET, EAST CHARLESTON, WV 25305 FAX: 304-558-4115 EMAIL: TARA.L.LYLE@WV.GOV CANCELLATION: THE DIRECTOR OF PURCHASING RESERVES THE RIGHT TO CANCEL THIS CONTRACT IMMEDIATELY UPON WRITTEN NOTICE TO THE VENDOR IF THE COMMODITIES AND/OR SERVICES SUPPLIED ARE OF AN INFERIOR QUALITY OR DO NOT CONFORM						



SEE REVERSE SIDE FOR TERMS AND CONDITIONS			
SIGNATURE	TELEPHONE	DATE	
<i>Jacques A. ...</i>	304-744-1321	8/30/2011	
TITLE	FEIN	ADDRESS CHANGES TO BE NOTED ABOVE	
Sales Consultant	451024981		

WHEN RESPONDING TO RFQ, INSERT NAME AND ADDRESS IN SPACE ABOVE LABELED 'VENDOR'

GENERAL TERMS & CONDITIONS REQUEST FOR QUOTATION (RFQ) AND REQUEST FOR PROPOSAL (RFP)

1. Awards will be made in the best interest of the State of West Virginia.
 2. The State may accept or reject in part, or in whole, any bid.
 3. Prior to any award, the apparent successful vendor must be properly registered with the Purchasing Division and have paid the required \$125 fee.
 4. All services performed or goods delivered under State Purchase Order/Contracts are to be continued for the term of the Purchase Order/Contracts, contingent upon funds being appropriated by the Legislature or otherwise being made available. In the event funds are not appropriated or otherwise available for these services or goods this Purchase Order/Contract becomes void and of no effect after June 30.
 5. Payment may only be made after the delivery and acceptance of goods or services.
 6. Interest may be paid for late payment in accordance with the *West Virginia Code*.
 7. Vendor preference will be granted upon written request in accordance with the *West Virginia Code*.
 8. The State of West Virginia is exempt from federal and state taxes and will not pay or reimburse such taxes.
 9. The Director of Purchasing may cancel any Purchase Order/Contract upon 30 days written notice to the seller.
 10. The laws of the State of West Virginia and the *Legislative Rules* of the Purchasing Division shall govern the purchasing process.
 11. Any reference to automatic renewal is hereby deleted. The Contract may be renewed only upon mutual written agreement of the parties.
 12. **BANKRUPTCY:** In the event the vendor/contractor files for bankruptcy protection, the State may deem this contract null and void, and terminate such contract without further order.
 13. **HIPAA BUSINESS ASSOCIATE ADDENDUM:** The West Virginia State Government HIPAA Business Associate Addendum (BAA), approved by the Attorney General, is available online at www.state.wv.us/admin/purchase/vrc/hipaa.htm and is hereby made part of the agreement. Provided that the Agency meets the definition of a Cover Entity (45 CFR §160.103) and will be disclosing Protected Health Information (45 CFR §160.103) to the vendor.
 14. **CONFIDENTIALITY:** The vendor agrees that he or she will not disclose to anyone, directly or indirectly, any such personally identifiable information or other confidential information gained from the agency, unless the individual who is the subject of the information consents to the disclosure in writing or the disclosure is made pursuant to the agency's policies, procedures, and rules. Vendor further agrees to comply with the Confidentiality Policies and Information Security Accountability Requirements, set forth in <http://www.state.wv.us/admin/purchase/privacy/noticeConfidentiality.pdf>.
 15. **LICENSING:** Vendors must be licensed and in good standing in accordance with any and all state and local laws and requirements by any state or local agency of West Virginia, including, but not limited to, the West Virginia Secretary of State's Office, the West Virginia Tax Department, and the West Virginia Insurance Commission. The vendor must provide all necessary releases to obtain information to enable the director or spending unit to verify that the vendor is licensed and in good standing with the above entities.
 16. **ANTITRUST:** In submitting a bid to any agency for the State of West Virginia, the bidder offers and agrees that if the bid is accepted the bidder will convey, sell, assign or transfer to the State of West Virginia all rights, title and interest in and to all causes of action it may now or hereafter acquire under the antitrust laws of the United States and the State of West Virginia for price fixing and/or unreasonable restraints of trade relating to the particular commodities or services purchased or acquired by the State of West Virginia. Such assignment shall be made and become effective at the time the purchasing agency tenders the initial payment to the bidder.
- I certify that this bid is made without prior understanding, agreement, or connection with any corporation, firm, limited liability company, partnership, or person or entity submitting a bid for the same material, supplies, equipment or services and is in all respects fair and without collusion or fraud. I further certify that I am authorized to sign the certification on behalf of the bidder or this bid.

INSTRUCTIONS TO BIDDERS

1. Use the quotation forms provided by the Purchasing Division. Complete all sections of the quotation form.
2. Items offered must be in compliance with the specifications. Any deviation from the specifications must be clearly indicated by the bidder. Alternates offered by the bidder as EQUAL to the specifications must be clearly defined. A bidder offering an alternate should attach complete specifications and literature to the bid. The Purchasing Division may waive minor deviations to specifications.
3. Unit prices shall prevail in case of discrepancy. All quotations are considered F.O.B. destination unless alternate shipping terms are clearly identified in the quotation.
4. All quotations must be delivered by the bidder to the office listed below prior to the date and time of the bid opening. Failure of the bidder to deliver the quotations on time will result in bid disqualifications: Department of Administration, Purchasing Division, 2019 Washington Street East, P.O. Box 50130, Charleston, WV 25305-0130
5. Communication during the solicitation, bid, evaluation or award periods, except through the Purchasing Division, is strictly prohibited (W.Va. C.S.R. §148-1-6.6).



State of West Virginia
 Department of Administration
 Purchasing Division
 2019 Washington Street East
 Post Office Box 50130
 Charleston, WV 25305-0130

Request for Quotation

HFO NUMBER
PRI10863

PAGE
2

ADDRESS CORRESPONDENCE TO ATTENTION OF:
TARA LYLE
304-558-2544

RFQ COPY

TYPE NAME/ADDRESS HERE

VENDOR

Worldwide Equipment of WV
Charleston Division
Po Box 8557
South Charleston WV 25303

SHIP TO

WV PRISON INDUSTRIES
617 LEON SULLIVAN WAY
CHARLESTON, WV
25301 304-558-2945

DATE PRINTED 07/28/2011	TERMS OF SALE	SHIP VIA	F.O.B.	FREIGHT TERMS
-----------------------------------	---------------	----------	--------	---------------

BID OPENING DATE: **08/31/2011** BID OPENING TIME **01:30PM**

LINE	QUANTITY	UOP	CAT. NO.	ITEM NUMBER	UNIT PRICE	AMOUNT
<p>TO THE SPECIFICATIONS OF THE BID AND CONTRACT HEREIN.</p> <p>BANKRUPTCY: IN THE EVENT THE VENDOR/CONTRACTOR FILES FOR BANKRUPTCY PROTECTION, THE STATE MAY DEEM THE CONTRACT NULL AND VOID, AND TERMINATE SUCH CONTRACT WITHOUT FURTHER ORDER.</p> <p>THE MODEL/BRAND/SPECIFICATIONS NAMED HEREIN ESTABLISH THE ACCEPTABLE LEVEL OF QUALITY ONLY AND ARE NOT INTENDED TO REFLECT A PREFERENCE OR FAVOR ANY PARTICULAR BRAND OR VENDOR. VENDORS WHO ARE BIDDING ALTERNATES SHOULD SO STATE AND INCLUDE PERTINENT LITERATURE AND SPECIFICATIONS. FAILURE TO PROVIDE INFORMATION FOR ANY ALTERNATES MAY BE GROUNDS FOR REJECTION OF THE BID. THE STATE RESERVES THE RIGHT TO WAIVE MINOR IRREGULARITIES IN BIDS OR SPECIFICATIONS IN ACCORDANCE WITH SECTION 148-1-4(F) OF THE WEST VIRGINIA LEGISLATIVE RULES AND REGULATIONS.</p> <p>VENDOR PREFERENCE CERTIFICATE</p> <p>THIS TEAM EXHIBIT HAS BEEN REPLACED BY THE ONLINE VERSION WHICH IS AVAILABLE HERE: HTTP://WWW.STATE.WV.US/ADMIN/PURCHASE/VRC/VENPREF.PDF</p> <p>NOTICE</p> <p>A SIGNED BID MUST BE SUBMITTED TO:</p> <p>DEPARTMENT OF ADMINISTRATION PURCHASING DIVISION BUILDING 15 2019 WASHINGTON STREET, EAST CHARLESTON, WV 25305-0130</p>						

SEE REVERSE SIDE FOR TERMS AND CONDITIONS

SIGNATURE <i>Jackie A. [Signature]</i>	TELEPHONE 304-744-1321	DATE 8/30/2011
TITLE Sales Consultant	FEIN 45102498	ADDRESS CHANGES TO BE NOTED ABOVE

WHEN RESPONDING TO RFQ, INSERT NAME AND ADDRESS IN SPACE ABOVE LABELED 'VENDOR'



State of West Virginia
 Department of Administration
 Purchasing Division
 2019 Washington Street East
 Post Office Box 50130
 Charleston, WV 25305-0130

Request for Quotation

RFQ NUMBER
 PRI10863

PAGE
 3

ADDRESS CORRESPONDENCE TO ATTENTION OF:
 TARA LYLE
 304-558-2544

VENDOR

RFQ COPY
 TYPE NAME/ADDRESS HERE
 Worldwide Equipment of WV
 Charleston Division
 PO Box 8557
 South Charleston WV 25303

SHIP TO

WV PRISON INDUSTRIES
 617 LEON SULLIVAN WAY
 CHARLESTON, WV
 25301 304-558-2945

DATE PRINTED	TERMS OF SALE	SHIP VIA	F.O.B.	FREIGHT TERMS
07/28/2011				

BID OPENING DATE: 08/31/2011 BID OPENING TIME 01:30PM

LINE	QUANTITY	UOP	CAT. NO.	ITEM NUMBER	UNIT PRICE	AMOUNT
THE BID SHOULD CONTAIN THIS INFORMATION ON THE FACE OF THE ENVELOPE OR THE BID MAY NOT BE CONSIDERED: SEALED BID BUYER:-----TL/32----- RFQ. NO.:-----PRI10863----- BID OPENING DATE:-----08/31/2011----- BID OPENING TIME:-----1:30 PM----- PLEASE PROVIDE A FAX NUMBER IN CASE IT IS NECESSARY TO CONTACT YOU REGARDING YOUR BID: 304-744-7852 CONTACT PERSON (PLEASE PRINT CLEARLY): Jackie Cummings						
***** THIS IS THE END OF RFQ PRI10863 ***** TOTAL:						81,106. ⁰⁰

SEE REVERSE SIDE FOR TERMS AND CONDITIONS

SIGNATURE <i>Jackie Cummings</i>	TELEPHONE 304-744-1321	DATE 8/30/2011
TITLE Sales Consultant FEIN 451024981	ADDRESS CHANGES TO BE NOTED ABOVE	

WHEN RESPONDING TO RFQ, INSERT NAME AND ADDRESS IN SPACE ABOVE LABELED 'VENDOR'



State of West Virginia
 Department of Administration
 Purchasing Division
 2019 Washington Street East
 Post Office Box 50130
 Charleston, WV 25305-0130

Request for Quotation

RFQ NUMBER: PRI10863

PAGE: 1

ADDRESS CORRESPONDENCE TO ATTENTION OF:
 TARA LYLE
 304-558-2544

RFQ COPY
 TYPE NAME/ADDRESS HERE

VENDOR

Worldwide Equipment of WV
 Charleston Division
 P.O. Box 8557
 South Charleston WV 25303

SHIP TO

WV PRISON INDUSTRIES
 617 LEON SULLIVAN WAY
 CHARLESTON, WV 25301 304-558-2945

DATE PRINTED	TERMS OF SALE	SHIP VIA	FOB	FREIGHT TERMS
08/17/2011				

BID OPENING DATE: 08/31/2011 BID OPENING TIME 01:30PM

LINE	QUANTITY	UOP	CAT NO	ITEM NUMBER	UNIT PRICE	AMOUNT
ADDENDUM NO. 1						
1. QUESTIONS AND ANSWERS ARE ATTACHED.						
2. ADDENDUM ACKNOWLEDGEMENT IS ATTACHED. THIS DOCUMENT SHOULD BE SIGNED AND RETURNED WITH YOUR BID. FAILURE TO SIGN AND RETURN MAY RESULT IN DISQUALIFICATION OF YOUR BID.						
EXHIBIT 10						
REQUISITION NO.: PRI10863						
ADDENDUM ACKNOWLEDGEMENT						
I HEREBY ACKNOWLEDGE RECEIPT OF THE FOLLOWING CHECKED ADDENDUM(S) AND HAVE MADE THE NECESSARY REVISIONS TO MY PROPOSAL, PLANS AND/OR SPECIFICATION, ETC.						
ADDENDUM NO.'S:						
NO. 1 .. ✓						
NO. 2						
NO. 3						
NO. 4						
NO. 5						
I UNDERSTAND THAT FAILURE TO CONFIRM THE RECEIPT OF THE ADDENDUM(S) MAY BE CAUSE FOR REJECTION OF BIDS.						

SEE REVERSE SIDE FOR TERMS AND CONDITIONS

SIGNATURE <i>Jacob A. ...</i>	TELEPHONE 304-744-1321	DATE 8/30/2011
TITLE Sales Consultant	FEIN H51024981	ADDRESS CHANGES TO BE NOTED ABOVE

WHEN RESPONDING TO RFQ, INSERT NAME AND ADDRESS IN SPACE ABOVE LABELED 'VENDOR'

**GENERAL TERMS & CONDITIONS
REQUEST FOR QUOTATION (RFQ) AND REQUEST FOR PROPOSAL (RFP)**

1. Awards will be made in the best interest of the State of West Virginia.
2. The State may accept or reject in part, or in whole, any bid.
3. Prior to any award, the apparent successful vendor must be properly registered with the Purchasing Division and have paid the required \$125 fee.
4. All services performed or goods delivered under State Purchase Order/Contracts are to be continued for the term of the Purchase Order/Contracts, contingent upon funds being appropriated by the Legislature or otherwise being made available. In the event funds are not appropriated or otherwise available for these services or goods this Purchase Order/Contract becomes void and of no effect after June 30.
5. Payment may only be made after the delivery and acceptance of goods or services.
6. Interest may be paid for late payment in accordance with the *West Virginia Code*.
7. Vendor preference will be granted upon written request in accordance with the *West Virginia Code*.
8. The State of West Virginia is exempt from federal and state taxes and will not pay or reimburse such taxes.
9. The Director of Purchasing may cancel any Purchase Order/Contract upon 30 days written notice to the seller.
10. The laws of the State of West Virginia and the *Legislative Rules* of the Purchasing Division shall govern the purchasing process.
11. Any reference to automatic renewal is hereby deleted. The Contract may be renewed only upon mutual written agreement of the parties.
12. **BANKRUPTCY:** In the event the vendor/contractor files for bankruptcy protection, the State may deem this contract null and void, and terminate such contract without further order.
13. **HIPAA BUSINESS ASSOCIATE ADDENDUM:** The West Virginia State Government HIPAA Business Associate Addendum (BAA), approved by the Attorney General, is available online at www.state.wv.us/admin/purchase/vrc/hipaa.htm and is hereby made part of the agreement. Provided that the Agency meets the definition of a Cover Entity (45 CFR §160.103) and will be disclosing Protected Health Information (45 CFR §160.103) to the vendor.
14. **CONFIDENTIALITY:** The vendor agrees that he or she will not disclose to anyone, directly or indirectly, any such personally identifiable information or other confidential information gained from the agency, unless the individual who is the subject of the information consents to the disclosure in writing or the disclosure is made pursuant to the agency's policies, procedures, and rules. Vendor further agrees to comply with the Confidentiality Policies and Information Security Accountability Requirements, set forth in <http://www.state.wv.us/admin/purchase/privacy/noticeConfidentiality.pdf>.
15. **LICENSING:** Vendors must be licensed and in good standing in accordance with any and all state and local laws and requirements by any state or local agency of West Virginia, including, but not limited to, the West Virginia Secretary of State's Office, the West Virginia Tax Department, and the West Virginia Insurance Commission. The vendor must provide all necessary releases to obtain information to enable the director or spending unit to verify that the vendor is licensed and in good standing with the above entities.
16. **ANTITRUST:** In submitting a bid to any agency for the State of West Virginia, the bidder offers and agrees that if the bid is accepted the bidder will convey, sell, assign or transfer to the State of West Virginia all rights, title and interest in and to all causes of action it may now or hereafter acquire under the antitrust laws of the United States and the State of West Virginia for price fixing and/or unreasonable restraints of trade relating to the particular commodities or services purchased or acquired by the State of West Virginia. Such assignment shall be made and become effective at the time the purchasing agency tenders the initial payment to the bidder.

I certify that this bid is made without prior understanding, agreement, or connection with any corporation, firm, limited liability company, partnership, or person or entity submitting a bid for the same material, supplies, equipment or services and is in all respects fair and without collusion or fraud. I further certify that I am authorized to sign the certification on behalf of the bidder or this bid.

INSTRUCTIONS TO BIDDERS

1. Use the quotation forms provided by the Purchasing Division. Complete all sections of the quotation form.
2. Items offered must be in compliance with the specifications. Any deviation from the specifications must be clearly indicated by the bidder. Alternates offered by the bidder as EQUAL to the specifications must be clearly defined. A bidder offering an alternate should attach complete specifications and literature to the bid. The Purchasing Division may waive minor deviations to specifications.
3. Unit prices shall prevail in case of discrepancy. All quotations are considered F.O.B. destination unless alternate shipping terms are clearly identified in the quotation.
4. All quotations must be delivered by the bidder to the office listed below prior to the date and time of the bid opening. Failure of the bidder to deliver the quotations on time will result in bid disqualifications: Department of Administration, Purchasing Division, 2019 Washington Street East, P.O. Box 50130, Charleston, WV 25305-0130
5. Communication during the solicitation, bid, evaluation or award periods, except through the Purchasing Division, is strictly prohibited (W.Va. C.S.R. §148-1-6.6).



State of West Virginia
 Department of Administration
 Purchasing Division
 2019 Washington Street East
 Post Office Box 50130
 Charleston, WV 25305-0130

Request for Quotation

RFQ NUMBER:
 PRI10863

PAGE:
 2

ADDRESS CORRESPONDENCE TO ATTENTION OF:
 TARA LYLE
 304-558-2544

RFQ COPY

TYPE NAME/ADDRESS HERE

Worldwide Equipment of WV
 Charleston Division
 P.O. Box 8557
 South Charleston, WV 25303

SHIP TO

WV PRISON INDUSTRIES
 617 LEON SULLIVAN WAY
 CHARLESTON, WV 25301 304-558-2945

DATE PRINTED	TERMS OF SALE	SHIP VIA	F.O.B.	FREIGHT TERMS
08/17/2011				

BID OPENING DATE: 08/31/2011 BID OPENING TIME 01:30PM

LINE	QUANTITY	UOP	CAT NO.	ITEM NUMBER	UNIT PRICE	AMOUNT
<p>VENDOR MUST CLEARLY UNDERSTAND THAT ANY VERBAL REPRESENTATION MADE OR ASSUMED TO BE MADE DURING ANY ORAL DISCUSSION HELD BETWEEN VENDOR'S REPRESENTATIVES AND ANY STATE PERSONNEL IS NOT BINDING. ONLY THE INFORMATION ISSUED IN WRITING AND ADDED TO THE SPECIFICATIONS BY AN OFFICIAL ADDENDUM IS BINDING.</p> <p>..... SIGNATURE <i>Jacko A. Curran</i></p> <p>Worldwide Equipment of WV COMPANY</p> <p>..8/30/2011 DATE</p> <p>NOTE: THIS ADDENDUM ACKNOWLEDGEMENT SHOULD BE SUBMITTED WITH THE BID.</p> <p>REV. 09/21/2009</p> <p>END OF ADDENDUM NO. 1</p>						
0001	1	EA		070-53	81,106. ⁰⁰	81,106. ⁰⁰
				DELIVERY TRUCK		

SEE REVERSE SIDE FOR TERMS AND CONDITIONS

SIGNATURE: *Jacko A. Curran* TELEPHONE: 304-744-1321 DATE: 8/30/2011

TITLE: Sales Consultant FEIN: 451024981 ADDRESS CHANGES TO BE NOTED ABOVE

WHEN RESPONDING TO RFQ, INSERT NAME AND ADDRESS IN SPACE ABOVE LABELED 'VENDOR'

PRI10863
Addendum No. 1

Q1: Is this unit to have a manual or automatic transmission? Both are listed in the specs.

A1: Automatic.

PRI10863

Specifications for a 2011 or newer delivery truck:

GVWR 33,000#, minimum

Diesel engine shall be a minimum of 260 hp, 660 lb-ft 7.68L displacement. Must meet 2010 emissions without the use of credits.

Heated fuel/water separator

Minimum 12 volt 130 amp alternator

Minimum two batteries with no less than 1200 cca total

Minimum 12 volt 4.8KW starter

AM/FM radio

Air conditioned cab

Information display

Dual electric horn

Minimum 18,357 BTU/h Heater/Defroster

LED marker lamps, stop/tail lights, back up lights, side flasher lights

Transmission to be Allison 2500RDS or equal

Single horizontal- driver side mounted inside frame rail exhaust system

Pto- electronic activation switch (electric hand throttle)

Transmission shall be manual 6-speed direct drive Eaton-fuller FS6406A minimum

Clutch 14" valeo-single plate self adjusting minimum

Front axle 12,000 lbs. Minimum

Front oil seals with clear caps

Front suspension minimum of 12,000 lbs tapered leaf

Front stabilizer bar

Front & rear wheels steel disc 22.5" x 8.25", minimum

Front tires 11r22.5g rated 12,350lbs. Premium highway tread, minimum

Rear tires 11r22.5g rated 23000 lbs. Highway traction, minimum

Single speed rear axle 21,000 lbs., minimum

Axle ratio 3.90:1 or equal

Rear suspension multi-leaf 23,500 lbs, minimum

Rear auxiliary springs single leaf

Bolted rear suspension

Wheelbase no less than 260"

Frame rail 120,000 psi rated

Inverted "I" frame reinforcement 120,000psi with total frame increased rbm to a minimum of 3,229,200

Nose cone on top of cab

Dual 75 gallon step fuel tanks

Dual ac/dc fuel tank heaters with manual switch to change from truck power to 110 ac power when plugged in via power cord

Abs-4- channel bendix air brake system 's' cam type

Rear dust shields

Minimum of 12.9 cfm water-cooled air compressor

Air intake compressor

Bumper front chromed steel thickness 5/32" minimum

Two front tow hooks

Hystec style cab to frame mounts

Dual electric horn

Single dual air horn mounted on roof

Tilt steering wheel

Cruise control

Interior roof lamp

Air conditioning

Am/fm stereo radio

Exterior mirrors shall be electric remote control, lighted, heated 102" wide load mirrors with built in 6"x7" convex section

Truck and body shall be painted white

Driver seat shall be air suspension, high – back cloth national 2000 series or equal with arm rest

Passenger seat shall be two man cloth

Frame mounted tool box 18"x18"x36", minimum

On-spot chains mounted

24' dry freight van body

Plywood lined 3/8" full, minimum

Inside height 97.12"

Roll up rear door 94"w x 91.25"h

Subframe 3"i-beam crossmembers on 12" centers with 4" longrail

4-extra crossmembers located at rear on 6" centers

1 1/8" hardwood floor, minimum

Threshold steel diamond plate 1/8" x 23"

Scuff-side galvanized steel 12 ga 16" high, minimum

Translucent roof

Two dome lights

Two rows e-track each side

3300lb. Cap. Tuc-a-way lift gate with 80"x48" aluminum Platform

Alum. Body sides

Fork lift package

½" plywood liner front, minimum

Scuff front galvanized steel 12ga. 16" high, minimum

Triangle kit & 5# fire exts

Side door, to be located on curb side of body

Warranty:

All bidders must provide a copy of the manufacturer's warranty.

Delivery:

Delivery cost should be included with your bid. The truck should be delivered to the agency within 60 days of award of the contract.

Award:

The contract will be awarded to one vendor with the lowest grand total meeting all of the specifications with the most complete bid.

RFQ No. PR110863

STATE OF WEST VIRGINIA
Purchasing Division

PURCHASING AFFIDAVIT

West Virginia Code §5A-3-10a states: No contract or renewal of any contract may be awarded by the state or any of its political subdivisions to any vendor or prospective vendor when the vendor or prospective vendor or a related party to the vendor or prospective vendor is a debtor and the debt owed is an amount greater than one thousand dollars in the aggregate.

DEFINITIONS:

"Debt" means any assessment, premium, penalty, fine, tax or other amount of money owed to the state or any of its political subdivisions because of a judgment, fine, permit violation, license assessment, defaulted workers' compensation premium, penalty or other assessment presently delinquent or due and required to be paid to the state or any of its political subdivisions, including any interest or additional penalties accrued thereon.

"Debtor" means any individual, corporation, partnership, association, limited liability company or any other form or business association owing a debt to the state or any of its political subdivisions. "Political subdivision" means any county commission; municipality; county board of education; any instrumentality established by a county or municipality; any separate corporation or instrumentality established by one or more counties or municipalities, as permitted by law; or any public body charged by law with the performance of a government function or whose jurisdiction is coextensive with one or more counties or municipalities. "Related party" means a party, whether an individual, corporation, partnership, association, limited liability company or any other form or business association or other entity whatsoever, related to any vendor by blood, marriage, ownership or contract through which the party has a relationship of ownership or other interest with the vendor so that the party will actually or by effect receive or control a portion of the benefit, profit or other consideration from performance of a vendor contract with the party receiving an amount that meets or exceeds five percent of the total contract amount.

EXCEPTION: The prohibition of this section does not apply where a vendor has contested any tax administered pursuant to chapter eleven of this code, workers' compensation premium, permit fee or environmental fee or assessment and the matter has not become final or where the vendor has entered into a payment plan or agreement and the vendor is not in default of any of the provisions of such plan or agreement.

Under penalty of law for false swearing (*West Virginia Code §61-5-3*), it is hereby certified that the vendor affirms and acknowledges the information in this affidavit and is in compliance with the requirements as stated.

WITNESS THE FOLLOWING SIGNATURE

Vendor's Name: Worldwide Equipment of WV

Authorized Signature: [Signature] Date: 8/30/2011

State of West Virginia

County of Kanawha, to-wit:

Taken, subscribed, and sworn to before me this 30 day of Aug., 2011.

My Commission expires July 13, 2011.

AFFIX SEAL HERE

NOTARY PUBLIC [Signature]

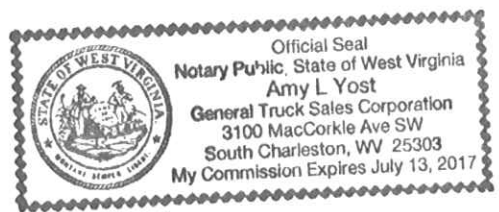

State of West Virginia VENDOR PREFERENCE CERTIFICATE

Certification and application* is hereby made for Preference in accordance with *West Virginia Code*, §5A-3-37. (Does not apply to construction contracts). *West Virginia Code*, §5A-3-37, provides an opportunity for qualifying vendors to request (at the time of bid) preference for their residency status. Such preference is an evaluation method only and will be applied only to the cost bid in accordance with the *West Virginia Code*. This certificate for application is to be used to request such preference. The Purchasing Division will make the determination of the Resident Vendor Preference, if applicable.

- 1. **Application is made for 2.5% resident vendor preference for the reason checked:**
 Bidder is an individual resident vendor and has resided continuously in West Virginia for four (4) years immediately preceding the date of this certification; or,
 Bidder is a partnership, association or corporation resident vendor and has maintained its headquarters or principal place of business continuously in West Virginia for four (4) years immediately preceding the date of this certification; or 80% of the ownership interest of Bidder is held by another individual, partnership, association or corporation resident vendor who has maintained its headquarters or principal place of business continuously in West Virginia for four (4) years immediately preceding the date of this certification; or,
 Bidder is a nonresident vendor which has an affiliate or subsidiary which employs a minimum of one hundred state residents and which has maintained its headquarters or principal place of business within West Virginia continuously for the four (4) years immediately preceding the date of this certification; or,
- 2. **Application is made for 2.5% resident vendor preference for the reason checked:**
 Bidder is a resident vendor who certifies that, during the life of the contract, on average at least 75% of the employees working on the project being bid are residents of West Virginia who have resided in the state continuously for the two years immediately preceding submission of this bid; or,
- 3. **Application is made for 2.5% resident vendor preference for the reason checked:**
 Bidder is a nonresident vendor employing a minimum of one hundred state residents or is a nonresident vendor with an affiliate or subsidiary which maintains its headquarters or principal place of business within West Virginia employing a minimum of one hundred state residents who certifies that, during the life of the contract, on average at least 75% of the employees or Bidder's affiliate's or subsidiary's employees are residents of West Virginia who have resided in the state continuously for the two years immediately preceding submission of this bid; or,
- 4. **Application is made for 5% resident vendor preference for the reason checked:**
 Bidder meets either the requirement of both subdivisions (1) and (2) or subdivision (1) and (3) as stated above; or,
- 5. **Application is made for 3.5% resident vendor preference who is a veteran for the reason checked:**
 Bidder is an individual resident vendor who is a veteran of the United States armed forces, the reserves or the National Guard and has resided in West Virginia continuously for the four years immediately preceding the date on which the bid is submitted; or,
- 6. **Application is made for 3.5% resident vendor preference who is a veteran for the reason checked:**
 Bidder is a resident vendor who is a veteran of the United States armed forces, the reserves or the National Guard, if, for purposes of producing or distributing the commodities or completing the project which is the subject of the vendor's bid and continuously over the entire term of the project, on average at least seventy-five percent of the vendor's employees are residents of West Virginia who have resided in the state continuously for the two immediately preceding years.

Bidder understands if the Secretary of Revenue determines that a Bidder receiving preference has failed to continue to meet the requirements for such preference, the Secretary may order the Director of Purchasing to: (a) reject the bid; or (b) assess a penalty against such Bidder in an amount not to exceed 5% of the bid amount and that such penalty will be paid to the contracting agency or deducted from any unpaid balance on the contract or purchase order.

By submission of this certificate, Bidder agrees to disclose any reasonably requested information to the Purchasing Division and authorizes the Department of Revenue to disclose to the Director of Purchasing appropriate information verifying that Bidder has paid the required business taxes, provided that such information does not contain the amounts of taxes paid nor any other information deemed by the Tax Commissioner to be confidential.

Under penalty of law for false swearing (*West Virginia Code*, §61-5-3), Bidder hereby certifies that this certificate is true and accurate in all respects; and that if a contract is issued to Bidder and if anything contained within this certificate changes during the term of the contract, Bidder will notify the Purchasing Division in writing immediately.

Bidder: Worldwide Equipment of WV Signed: Jackie A. [Signature]
 Date: 8/30/2011 Title: Sales Consultant

*Check any combination of preference consideration(s) indicated above, which you are entitled to receive.



THE TRUCK PEOPLE

WORLDWIDE EQUIPMENT ENTERPRISES, INC.

CHARLESTON DIVISION

August 31, 2011

WORLDWIDE EQUIPMENT DIVISIONS AND SUBSIDIARIES

Kentucky

Lexington
(859) 281-5152
Middlesboro
(606) 248-5100
Prestonsburg
(606) 874-2172
Somerset
(606) 679-4321

West Virginia

Charleston
(304) 744-1321
Huntington
(304) 736-3401
Jane Lew
(304) 884-7815
Princeton
(304) 425-7511

Virginia

Abingdon
(276) 628-8103

Tennessee

Chattanooga
(423) 892-8524
Knoxville
(865) 688-4300
Knoxville - Asheville Hwy
(865) 637-4333

Ohio

Cincinnati
(513) 563-6363
Dayton
(937) 278-5775

**Worldwide Equipment
Leasing, Inc.**
Lexington, KY
(859) 233-3740

Worldwide Fabricating and Manufacturing, Inc.

Lowmansville, KY
(606) 297-1200

State of West Virginia
Department of Administration
Purchasing Division
State Capital Complex
2019 Washington Street, East
PO Box 50130
Charleston, WV 25305-0130

RE: RFQ PRI10863 WV Prisons Industry Delivery Truck

Ms. Lyle,

Thank you for this opportunity to submit a proposal on your vehicle needs.

Please find attached the vehicle build summary for a Hino 338 with a 24' box and a 3,300 lb liftgate.

This unit meets or exceeds your requirements with the following exceptions:

Chassis

Rear axle ratio is 5.57 instead of the requested 3.90.
Rear suspension is a 21,000 lb semi elliptical instead of a 23,500 multi-leaf.
Maximum frame RBM is 1,280,000 not 3,229,200.
Fuel tanks are dual 52 gallon instead of the requested dual 75's.
Water cooled air compressor is a 10.3 cfm not 12.9.
On spots are not included in our pricing.
Fuel tank heaters are not included in our pricing.

Body

Inside height is 96" not 97.12"
Roll up rear door is 88"w x 90.5"h not 94"w x 91.25"h.

Delivery

We are currently in the middle of a model year change. This unit could be a 2012 or a 2013 depending on receipt of order. We estimate this unit could take up to 220 days for delivery.

Thank you again for this opportunity.

Jack Cummings
Sales Consultant

Customer: WV Prison Industries State Of Quote Name: WV Prison Industries Sta
 WV
 Dealership: Worldwide Equipment



Quotation Details

Quote Information
 Quote Name
 Expiration Date
 Model
 Transmission
 Wheelbase

WV Prison Industries State Of WV
 03/07/2013
 2012 Hino 338
 Auto - Allison 2500RDS (PTO)
 271.0

Standard Options		
Qty	Order Code	Description
1	ENGINE	J08E-VB Turbo charged and intercooled with glow plugs, 6 cylinder, In-line water-cooled; Max Output 260hp @2500rpm; Max Torque 660lb.ft. @ 1500rpm; 7.68L displacement, EPA10 Emissions Certified.
1	EXHBRAKE	Exhaust brake with driver controls.
1	FUELFILT	Davco 230 FuelPro Heated fuel/water separator.
1	ALT	12 volt 130 amp Delco brush alternator.
1	BATTERY	Two 12 volt parallel connection, 1200 CCA.
1	STARTER	12 volt 4.8kw Denso starter
1	RADIO	AM/FM radio with single CD, two speakers.
1	AIRCOND	Air conditioned - Denso 134
1	DISPLAY	Information display listing: Instant and trip fuel consumption, Diesel Particulate Reduction System performance/status, maintenance intervals, engine and vehicle diagnostics.
1	GAUGES	Speedometer mph (km/h), odometer, fuel gauge, coolant temp gauge, engine tachometer, air pressure gauge.
1	FTGRILL	Chrome plated front grille.
1	HEAT/DEF	18,357 BTU/h Heater/Defroster.
1	LAMPS	Trucklite LED marker lamps, stop/tail lights, back-up lights, side-flasher lights.
1	MISC	Miscellaneous Standard Equipment - Cruise control, power steering with tilt and telescopic steering column, cup holders, cigarette lighter, fully trimmed rear panel with coat hook, two overhead compartments, two door pockets, sun visors.

Customer: WV Prison Industries State Of Quote Name: WV Prison Industries Sta
WV

Dealership: Worldwide Equipment



Standard Options			
Qty	Order Code		Description
1	INDICATORS		Warning indicators for: oil pressure, brake pressure, coolant level, battery charge, high beam, turn signal, parking brake, engine control system and ABS.
1	EMISS10		Surcharge for EPA10 Emissions.
1	FREIGHT		Equalized Freight Charge.
1	COOLSYS		Allison 3000 - 6.08 gallon cooling system capacity; Eaton FS6406A - 6.21 gallon capacity.
1	OIL		16.15 quart capacity.
1	WARRANTY_05		Basic Vehicle-24 months unlimited mileage; Engine-36 months unlimited mileage; Engine-60 month Extended Coverage, 250,000 miles (includes injectors, fuel supply pump and turbo); Emission-60 months 100,000 miles; Frame Rails & Cross Members-48 months unlimited mileage; Cab-48 months unlimited mileage; ABS-24-36 months 300,000 miles.
1	HWATCH_05		Roadside assistance: 3-year unlimited roadside assistance including lockout, *out of fuel/DEF, battery jumpstart, information, and warranty towing (2 year coverage). *Fluids are customer pay responsibility.
1	GVWR		Gross Vehicle Weight Rating-33,000 lbs.
1	AIRTANK		68 liter tank, compressor 23.25 CPW (227cm3/rev.@2900rpm).
1	BRAKES		Full air dual circuit "S" cam type, leading and trailing shoes with automatic adjustment and Antilock Brake System (ABS). Front Brakes: 15.0" diameter x 4.0" pad area x 0.73" thickness: Rear Brakes: 16.5" x 7.0" x 0.85".
1	AIRDRYER		Bendix - heated air dryer.
1	WHEELS		Powder Coated 22.5" x 8.25" 10-stud disc.
1	TIRES		Front tires - Bridgestone 11R 22.5 R250F Rib pattern; Rear tires - Bridgestone 11R 22.5 M725 Lug pattern.
1	AXLES		Front axle Meritor MFS12 reversed Elliot "I" beam oil lubricated 12,000 lb. rating. Rear axle Meritor RS21-145 full-floating single reduction single speed by hypoid gearings, 21,000 lb. rating.

Customer: WV Prison Industries State Of Quote Name: WV Prison Industries Sta
WV

Dealership: Worldwide Equipment



Standard Options			
Qty	Order Code		Description
1	SPRINGS		Front spring: Taper-leaf springs with shock absorbers, 12,000 lb. rating; Rear spring: Semi-elliptic main and auxiliary helper-leaf spring, 21,000 lb. rating.
1	AXLESTD		

Premium/Upgrade Options			
Qty	Order Code		Description
1	338-12V		271" WB / 203.6" CA
1	HB8RDS25		Auto - Allison 2500RDS (PTO)
1	CLDS		Cold Package - engine block heater and power side heated mirrors.
1	ZSRSF1-LO		Sears Seat - Fabric upgrade (Black/Silver) Driver only - std bench passenger.
1	HORZA		Air horn.
1	SAFETY KIT-LO		Fire Extinguisher ABC 2.5MP, Triangle Kit (17 1/4" wide x 16 1/2" high).
1	STD52X2		Dual 52 gallon aluminum fuel tanks
1	120K		Frame Rail - 120k psi
1	BMP08		Bumper-Chrome with 2 hooks.
1	No_SalesTax		No Sales Tax

ALUMINUM VAN BODY QUOTATION

LENGTH: 24' I.D. WIDTH: 96" O.D. HEIGHT: 96" I.D.

Construction:	(.040) Pre-painted white aluminum panels with high strength extruded aluminum (not steel) "Z" posts on 16" centers. Seven front wall posts (not five) for added strength and durability. Extruded aluminum front corner radius posts, (not roll formed) for maximum strength.
Roof:	(.060) translucent roof panel with anti-snag roof bows on 24" centers, "Zephyr" 12" fuel saving roof radius design with heavy-duty cast aluminum (not plastic) corner castings.
Rear Frame:	11 Ga. Galvaneal steel, internally and externally reinforced, and gusseted at all stress points, painted to match.
Side Door(s):	45" x 76" DuraPlate single panel construction at standard location on <i>curbside</i> with heavy duty extruded aluminum hinges, exclusive internal bar lock, stirrup step below.
Rear Door:	Standard plastic covered ¾" plywood roll up, 88" wide x 90.5" high clear opening. Stainless steel rivets and "E" coated hardware.
Rear:	Interlift ILP-33 tuck under liftgate, 3300 lb. capacity, 80" x 48" aluminum platform, level ride operation, HD dock bumper, rubber bumper blocks, cab cut off switch
Grab Handle(s):	Curb side and road side on rear frame.
Rear Lighting:	Use OEM tail lights.
Floor:	1-1/8" high quality domestic laminated hardwood. 24" x 1/8" steel threshold plate at rear, with front edge routed into flooring.
Cross members:	3" steel I-Beam cross members on 12" centers with full steel wheel pan support over wheel area.
Interior Sides:	Sides - 3/8" full height premium plywood.
Interior Front:	Front - 1/2" full height premium plywood.
Interior Ties:	Sides - Two (2) row(s) recessed "E" Track @ ___ & ___" on center. Front - None.
Scuff Plate:	Sides - 16" x 12 Ga. smooth steel. Front - 16" x 12 Ga. smooth steel extending below floor, welded to front understructure for maximum front wall strength.
Lights:	Interior - Two (2) dome light(s) with switch at rear, inside door on curbside. <i>Note: When switch is supplied by chassis OEM, dome light will be wired to factory switch in cab.</i> Exterior - per FMVSS - 108 with reflectors.
Undercoating:	Petroleum base undercoating applied, (not paint) full understructure.
Mounting:	Hardwood isolator with 5/8" zinc plated U-bolts installed through custom cut steel crush pipes between chassis frame. Structural steel channel anti-shift "side standards" welded to structural steel long sills. Complete factory mounting on drop shipped chassis with "U.S. Truck Body" or customer supplied mud flaps.
Understructure:	Unless noted below in ADDITIONAL FEATURES, this body is quoted and built for a single axle chassis. Tandem axle chassis require the <i>additional cost option</i> for our <i>Tandem Axle Reinforcement Package</i> .

ADDITIONAL FEATURES INCLUDED:

1. Four extra cross members at rear on 6" centers.
2. 4" long sills.
3. One Day Mount with liftgate.

ILP PALLET PRO

2500 and 3300 lbs. Capacity

MBB PALFINGER

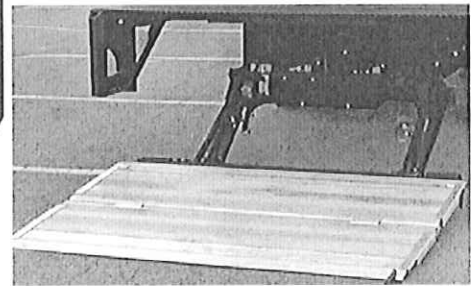
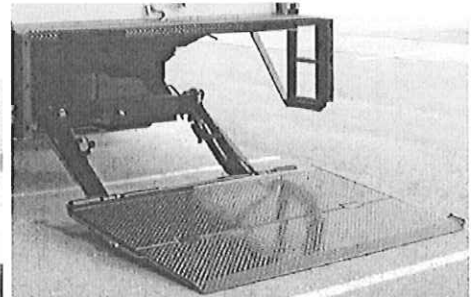
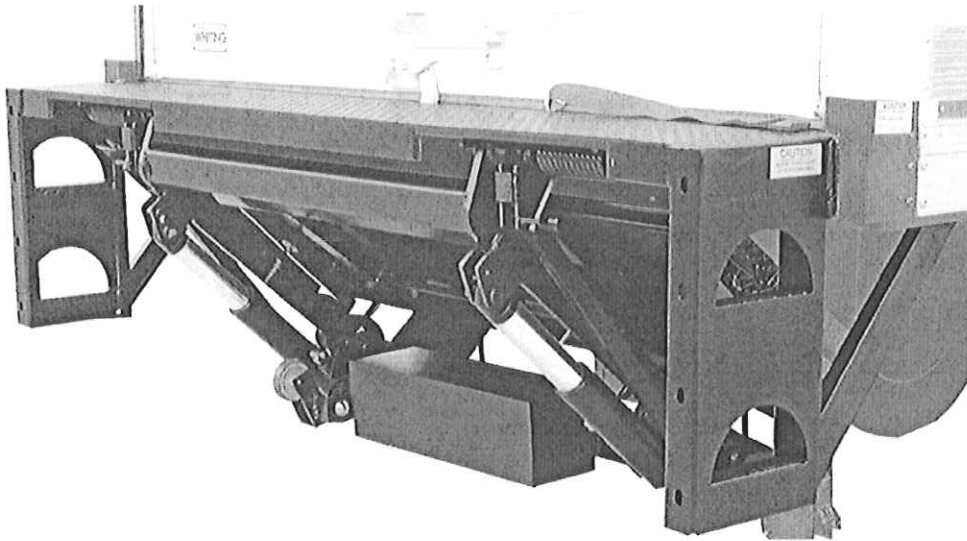

—OPTIMIZED—
FLEXIBILITY
DURABILITY
PROFITABILITY

The ILP Pallet Pro provides a lot of value for a small premium. Level ride platforms available in a variety of sizes from 48", 54", 60" x 80". Units are available in several steel and aluminum combinations.

LARGE Platform Lift! SMALL Platform Price!

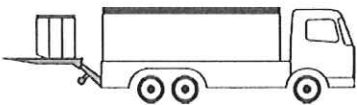

HEAVY DUTY CONSTRUCTION

- Bushings & zerks at all pivot points
- Heat treated pins
- Wide lift arm:
 - Provides added stability
 - Accepts a fixed hitch
- Thermo protected powerpack
- Increases life of components
- 150 AMP circuit breaker

BUILT IN STANDARD/ SAFETY FEATURES

- Dual cylinder stability
- Cab shut off switch
- Hydraulic cylinder locks on cylinder ports
- Adjustable roller and dual torsion assist offer minimum effort for platform folding
- Level ride platform
- Wide bed height range:
 - The 48" platform unit can be installed on as low as 38" laden bed height/up to 53" unladen

The MBB PALFINGER Pallet Pro, offering a platform size, level ride and lift capacity to handle many palletized or carted freight safely at a budget price.

MBB PALFINGER liftgates are pre-filled with aerospace hydraulic fluid. Our standard hydraulic cylinder lock provides added stability, better user control and improved safety.

The two cylinder mid arm design can accommodate a fixed receiver hitch. The platform rotates on an adjustable roller to adapt for different bed height installations.

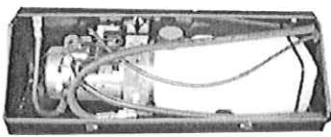

The thermo protected PowerPack is fully enclosed in a H/D powder coated steel box for protection and easy inspection. By using over sized quality components, we minimize maintenance and downtime.



The ILP incorporates our double torsions on both the main and folded section. The unique leveling joint on the ILP does not rotate on the ground. This makes the ILP an exceptionally smooth operating lift.

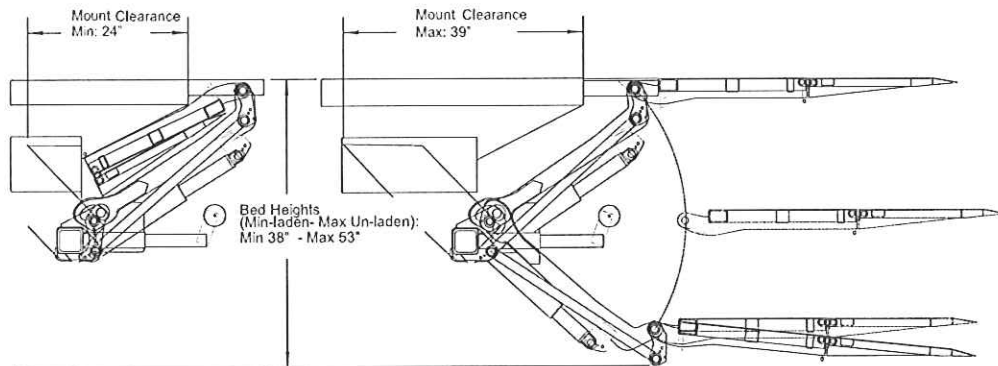

LIFTGATE OPTIONS:

- Auxiliary truck and trailer kits
- Dock bumpers
- Rubber pads
- Cart stops
- DOT rear impact guard
- Extra heavy duty trailer dock bumpers
- Hand held remote
- Aluminum tip sections
- All aluminum platforms
- Wireless remote
- 2" Receiver hitch

Model	Lifting Capacity (lbs)	Platform Length (inches)	Platform Width (inches)	Bed Height (inches)	Approx. Weight (lbs)	Mount Clearance (inches)
ILP 25	2500	48	80	38 - 53	750	21 - 30
ILP 33	3300	48	80	38 - 53	840	21 - 30
ILP 33	3300	54	80	45 - 55	900	24 - 34
ILP 33	3300	60	80	45 - 55	930	24 - 34