

Thomasville®

DREXEL HERITAGE®

Lane®  
HOME FURNISHINGS

Broyhill®

State of West Virginia  
Department of Administration  
Purchasing Division  
2019 Washington Street East  
Post Office Box 50130  
Charleston, WV 25305-0130

Dear Mr. Whittaker:

Enclosed is Thomasville's bid for DNRB12101. Please note that the activity table/desk, #8582-CT1104, which is your item number 4 on the bid, is quoted without a strip of three outlets. The price based on FOB destination for this table/desk is \$231.58.

As you probably know, there is a shortage of outlets at Blackwater Falls. Should the customer elect to purchase the table/desk from Thomasville, it can be produced for a FOB destination price of \$238.28. The model number for the table/desk with the outlets is #8582-CT1104-2. I have attached a sketch behind this letter that shows the table/desk with the three outlets.

Should you have any further questions, please advise.

Respectfully Submitted,



Paige Via

Paige Via  
Thomasville Furniture  
105 Holman Rd.  
Williamsburg, VA 23185-5552  
Phone: 757-565-2145  
Fax: 757-565-9623  
Cell: 757-784-3015  
[MPaigeVia@gmail.com](mailto:MPaigeVia@gmail.com)  
[www.contract.thomasville.com](http://www.contract.thomasville.com)

RECEIVED  
2012 MAR 27 AM 9:49  
WV PURCHASING  
DIVISION

Thomasville Furniture Industries  
Custom Product

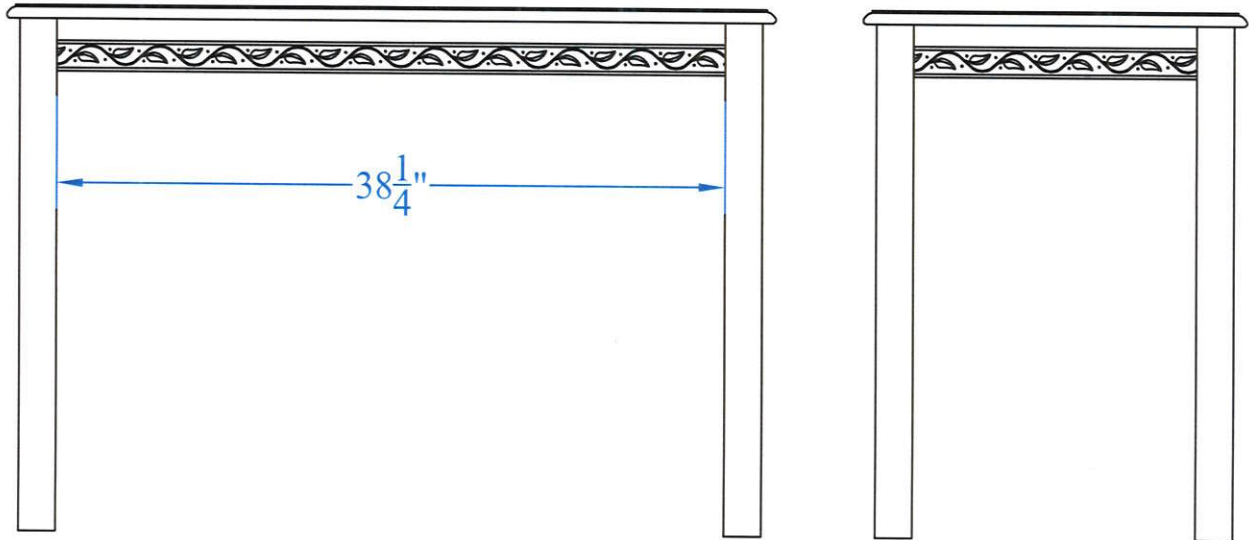
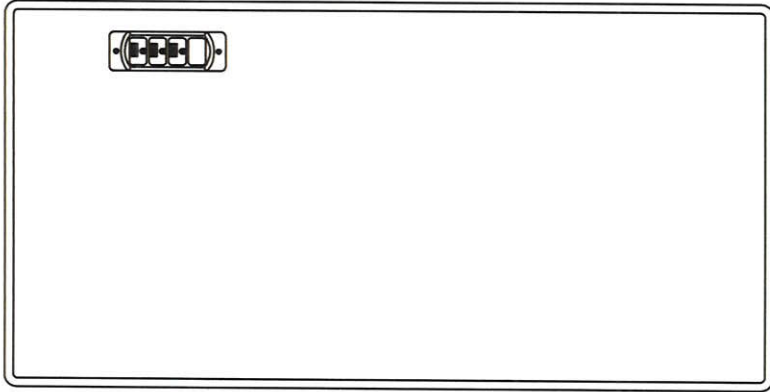

8582 Table

44" W x 22" D x 30" H  
Lumber Banded Laminate Top, Triple Electrical Outlet in  
top, KD Construction.  
Apron to Floor: 26-1/4"

Via: E-22217  
Blackwater Falls State Park; West Virginia

CT1104-2  
Estimated Weight (lbs): 43  
Estimated Cubes (cu '): 4.7

Suite: Changeables  
Finish: 8582 Light Cherry  
Cherry Veneers and Select Hardwood Solids  
50D Molding  
Outlet: Furnlite FC731



State of West Virginia  
 Department of Administration  
 Purchasing Division  
 2019 Washington Street East  
 Post Office Box 50130  
 Charleston, WV 25305-0130

# Request for Quotation

RFQ NUMBER  
 DNRB12101

PAGE  
 1

ADDRESS CORRESPONDENCE TO ATTENTION OF:  
 FRANK WHITTAKER  
 304-558-2316

RFQ COPY

TYPE NAME/ADDRESS HERE  
 THOMASVILLE FURNITURE IND., INC.  
 P.O. BOX 339  
 THOMASVILLE, NC 27361-0339  
 (336)472-4044  
 (757)565-9623 WILLIAMSBURG FAX

VENDOR

SHIP TO

DIVISION OF NATURAL RESOURCES  
 VARIOUS LOCALES AS INDICATED  
 BY ORDER

DATE PRINTED 02/29/2012	TERMS OF SALE NET 30	SHIP VIA WORLDWIDE LOGISTICS	F.O.B. DESTINATION	FREIGHT TERMS 30 DAYS
BID OPENING DATE: 03/28/2012		BID OPENING TIME 01:30PM		

LINE	QUANTITY	UOP	CAT. NO.	ITEM NUMBER	UNIT PRICE	AMOUNT
0001	1	LS		420-40		
<p>FURNITURE</p> <p>THE WEST VIRGINIA PURCHASING DIVISION, FOR THE AGENCY THE WEST VIRGINIA DIVISION OF NATURAL RESOURCES IS SOLICITING BIDS FOR AN OPEN-END CONTRACT TO PROVIDE FURNITURE ITEMS FOR VARIOUS STATE PARKS PER THE ATTACHED SPECIFICATIONS.</p> <p>ALL TECHNICAL QUESTIONS MUST BE SUBMITTED IN WRITING TO FRANK WHITTAKER IN THE WV PURCHASING DIVISION VIA EMAIL AT FRANK.M.WHITTAKER@WV.GOV OR VIA FAX AT 304-558-4115. DEADLINE FOR ALL TECHNICAL QUESTIONS IS 03/14/2012 AT 4:00 PM. ALL TECHNICAL QUESTIONS WILL BE ADDRESSED BY ADDENDUM AFTER THE DEADLINE.</p> <p>EXHIBIT 3</p> <p>LIFE OF CONTRACT: THIS CONTRACT BECOMES EFFECTIVE ON April 2, 2012 AND EXTENDS FOR A PERIOD OF ONE (1) YEAR OR UNTIL SUCH "REASONABLE TIME" THEREAFTER AS IS NECESSARY TO OBTAIN A NEW CONTRACT OR RENEW THE ORIGINAL CONTRACT. THE "REASONABLE TIME" PERIOD SHALL NOT EXCEED TWELVE (12) MONTHS. DURING THIS "REASONABLE TIME" THE VENDOR MAY TERMINATE THIS CONTRACT FOR ANY REASON UPON GIVING THE DIRECTOR OF PURCHASING 30 DAYS WRITTEN NOTICE.</p> <p>UNLESS SPECIFIC PROVISIONS ARE STIPULATED ELSEWHERE IN THIS CONTRACT DOCUMENT BY THE STATE OF WEST VIRGINIA, ITS AGENCIES, OR POLITICAL SUBDIVISIONS, THE</p>						

SEE REVERSE SIDE FOR TERMS AND CONDITIONS

TITLE <i>Paula Lee</i>		TELEPHONE (757)565-2145	DATE 3/16/12
CONTRACT MARKETING REP		FEIN 56-0906-574	ADDRESS CHANGES TO BE NOTED ABOVE

WHEN RESPONDING TO RFQ, INSERT NAME AND ADDRESS IN SPACE ABOVE LABELED 'VENDOR'



State of West Virginia  
 Department of Administration  
 Purchasing Division  
 2019 Washington Street East  
 Post Office Box 50130  
 Charleston, WV 25305-0130

# Request for Quotation

RFQ NUMBER  
 DNRB12101

PAGE  
 2

ADDRESS CORRESPONDENCE TO ATTENTION OF:  
 FRANK WHITTAKER  
 304-558-2316

RFQ COPY

TYPE NAME/ADDRESS HERE  
 THOMASVILLE FURNITURE IND., INC.

P.O. BOX 339

THOMASVILLE, NC 27361-0339

(336)472-4044

(757)565-9623 FAX WILLIAMSBURG

VENDOR

SHIP TO

DIVISION OF NATURAL RESOURCES  
 VARIOUS LOCALES AS INDICATED  
 BY ORDER

DATE PRINTED 02/29/2012	TERMS OF SALE NET 30	SHIP VIA WORLDWIDE LOGISTICS	F.O.B. DESTINATION	FREIGHT TERMS 30 DAYS
BID OPENING DATE: 03/28/2012		BID OPENING TIME 01:30PM		

LINE	QUANTITY	UOP	CAT. NO.	ITEM NUMBER	UNIT PRICE	AMOUNT
<p>TERMS, CONDITIONS, AND PRICING SET FORTH HEREIN ARE FIRM FOR THE LIFE OF THE CONTRACT.</p> <p>RENEWAL: THIS CONTRACT MAY BE RENEWED UPON THE MUTUAL WRITTEN CONSENT OF THE SPENDING UNIT AND VENDOR, SUBMITTED TO THE DIRECTOR OF PURCHASING THIRTY (30) DAYS PRIOR TO THE EXPIRATION DATE. SUCH RENEWAL SHALL BE IN ACCORDANCE WITH THE TERMS AND CONDITIONS OF THE ORIGINAL CONTRACT AND SHALL BE LIMITED TO TWO (2) ONE (1) YEAR PERIODS.</p> <p>CANCELLATION: THE DIRECTOR OF PURCHASING RESERVES THE RIGHT TO CANCEL THIS CONTRACT IMMEDIATELY UPON WRITTEN NOTICE TO THE VENDOR IF THE COMMODITIES AND/OR SERVICES SUPPLIED ARE OF AN INFERIOR QUALITY OR DO NOT CONFORM TO THE SPECIFICATIONS OF THE BID AND CONTRACT HEREIN.</p> <p>OPEN MARKET CLAUSE: THE DIRECTOR OF PURCHASING MAY AUTHORIZE A SPENDING UNIT TO PURCHASE ON THE OPEN MARKET, WITHOUT THE FILING OF A REQUISITION OR COST ESTIMATE, ITEMS SPECIFIED ON THIS CONTRACT FOR IMMEDIATE DELIVERY IN EMERGENCIES DUE TO UNFORESEEN CAUSES (INCLUDING BUT NOT LIMITED TO DELAYS IN TRANSPORTATION OR AN UNANTICIPATED INCREASE IN THE VOLUME OF WORK.)</p> <p>QUANTITIES: QUANTITIES LISTED IN THE REQUISITION ARE APPROXIMATIONS ONLY, BASED ON ESTIMATES SUPPLIED BY THE STATE SPENDING UNIT. IT IS UNDERSTOOD AND AGREED THAT THE CONTRACT SHALL COVER THE QUANTITIES ACTUALLY ORDERED FOR DELIVERY DURING THE TERM OF THE CONTRACT, WHETHER MORE OR LESS THAN THE QUANTITIES SHOWN.</p> <p>ORDERING PROCEDURE: SPENDING UNIT(S) SHALL ISSUE A WRITTEN STATE CONTRACT ORDER (FORM NUMBER WV-39) TO</p>						

SEE REVERSE SIDE FOR TERMS AND CONDITIONS

JATONE  
*Ray D*  
 TITLE CONTRACT MARKETING REP  
 FEIN 56-0906-574  
 TELEPHONE (757)565-2145  
 DATE 3/16/12  
 ADDRESS CHANGES TO BE NOTED ABOVE

WHEN RESPONDING TO RFQ, INSERT NAME AND ADDRESS IN SPACE ABOVE LABELED 'VENDOR'



State of West Virginia  
 Department of Administration  
 Purchasing Division  
 2019 Washington Street East  
 Post Office Box 50130  
 Charleston, WV 25305-0130

# Request for Quotation

RFQ NUMBER  
 DNRB12101

PAGE  
 3

ADDRESS CORRESPONDENCE TO ATTENTION OF:  
 FRANK WHITTAKER  
 304-558-2316

RFQ COPY

TYPE NAME/ADDRESS HERE  
 THOMASVILLE FURNITURE IND., INC.  
 P.O. BOX 339  
 THOMASVILLE, NC 27361-0339  
 (336)472-4044  
 (757)565-9623 WILLIAMSBURG FAX

DIVISION OF NATURAL RESOURCES  
 VARIOUS LOCALES AS INDICATED  
 BY ORDER

DATE PRINTED 02/29/2012	TERMS OF SALE NET 30	SHIP VIA WORLDWIDE LOGISTICS	F.O.B. DESTINATION	FREIGHT TERMS 30 DAYS
BID OPENING DATE: 03/28/2012		BID OPENING TIME 01:30PM		

LINE	QUANTITY	UOP	CAT NO.	ITEM NUMBER	UNIT PRICE	AMOUNT
------	----------	-----	---------	-------------	------------	--------

THE VENDOR FOR COMMODITIES COVERED BY THIS CONTRACT. THE ORIGINAL COPY OF THE WV-39 SHALL BE MAILED TO THE VENDOR AS AUTHORIZATION FOR SHIPMENT, A SECOND COPY MAILED TO THE PURCHASING DIVISION, AND A THIRD COPY RETAINED BY THE SPENDING UNIT.

BANKRUPTCY: IN THE EVENT THE VENDOR/CONTRACTOR FILES FOR BANKRUPTCY PROTECTION, THE STATE MAY DEEM THE CONTRACT NULL AND VOID, AND TERMINATE SUCH CONTRACT WITHOUT FURTHER ORDER.

THE TERMS AND CONDITIONS CONTAINED IN THIS CONTRACT SHALL SUPERSEDE ANY AND ALL SUBSEQUENT TERMS AND CONDITIONS WHICH MAY APPEAR ON ANY ATTACHED PRINTED DOCUMENTS SUCH AS PRICE LISTS, ORDER FORMS, SALES AGREEMENTS OR MAINTENANCE AGREEMENTS, INCLUDING ANY ELECTRONIC MEDIUM SUCH AS CD-ROM.

REV. 01/17/2012

NOTICE

A SIGNED BID MUST BE SUBMITTED TO:

DEPARTMENT OF ADMINISTRATION  
 PURCHASING DIVISION  
 BUILDING 15  
 2019 WASHINGTON STREET, EAST  
 CHARLESTON, WV 25305-0130

THE BID SHOULD CONTAIN THIS INFORMATION ON THE FACE OF THE ENVELOPE OR THE BID MAY NOT BE CONSIDERED:

SEE REVERSE SIDE FOR TERMS AND CONDITIONS

SIGNATURE <i>Page Sea</i>	TELEPHONE (757)565-2145	DATE 3/16/12
TITLE CONTRACT MARKETING REP	FEIN 56-0906-574	ADDRESS CHANGES TO BE NOTED ABOVE

WHEN RESPONDING TO RFQ, INSERT NAME AND ADDRESS IN SPACE ABOVE LABELED 'VENDOR'



State of West Virginia  
 Department of Administration  
 Purchasing Division  
 2019 Washington Street East  
 Post Office Box 50130  
 Charleston, WV 25305-0130

**Request for  
 Quotation**

RFO NUMBER  
 DNRB12101

PAGE  
 4

ADDRESS CORRESPONDENCE TO ATTENTION OF:  
 FRANK WHITTAKER  
 304-558-2316

RFQ COPY

V  
E  
N  
D  
O  
R

TYPE NAME/ADDRESS HERE  
 THOMASVILLE FURNITURE IND., INC.  
 P.O. BOX 339  
 THOMASVILLE, NC 27361-0339  
 (336)472-4044  
 (757)565-9623 WILLIAMSBURG FAX

S  
H  
I  
P  
T  
O

DIVISION OF NATURAL RESOURCES  
 VARIOUS LOCALES AS INDICATED  
 BY ORDER

DATE PRINTED	TERMS OF SALE	SHIP VIA	F.O.B.	FREIGHT TERMS
02/29/2012	NET 30	WORLDWIDE LOGISTICS	DESTINATION	30 DAYS
BID OPENING DATE: 03/28/2012		BID OPENING TIME 01:30PM		

LINE	QUANTITY	UOP	CAT NO.	ITEM NUMBER	UNIT PRICE	AMOUNT
SEALED BID						
BUYER:				44		
RFQ. NO.:				DNRB12101		
BID OPENING DATE:				03/28/2012		
BID OPENING TIME:				1:30 PM		
PLEASE PROVIDE A FAX NUMBER IN CASE IT IS NECESSARY TO CONTACT YOU REGARDING YOUR BID:						
(757)565-9623						
CONTACT PERSON (PLEASE PRINT CLEARLY):						
PAIGE VIA						
***** THIS IS THE END OF RFQ DNRB12101 ***** TOTAL:						\$47,786.67

SEE REVERSE SIDE FOR TERMS AND CONDITIONS

ATURE *Paige Via*      TELEPHONE (757)565-2145      DATE 3/16/12  
 TITLE CONTRACT MARKETING REP      FEIN 56-0906-574      ADDRESS CHANGES TO BE NOTED ABOVE

WHEN RESPONDING TO RFQ, INSERT NAME AND ADDRESS IN SPACE ABOVE LABELED 'VENDOR'

**GENERAL TERMS & CONDITIONS**  
**REQUEST FOR QUOTATION (RFQ) AND REQUEST FOR PROPOSAL (RFP)**

1. Awards will be made in the best interest of the State of West Virginia.
2. The State may accept or reject in part, or in whole, any bid.
3. Prior to any award, the apparent successful vendor must be properly registered with the Purchasing Division and have paid the required \$125 fee.
4. All services performed or goods delivered under State Purchase Order/Contracts are to be continued for the term of the Purchase Order/Contracts, contingent upon funds being appropriated by the Legislature or otherwise being made available. In the event funds are not appropriated or otherwise available for these services or goods this Purchase Order/Contract becomes void and of no effect after June 30.
5. Payment may only be made after the delivery and acceptance of goods or services.
6. Interest may be paid for late payment in accordance with the *West Virginia Code*.
7. Vendor preference will be granted upon written request in accordance with the *West Virginia Code*.
8. The State of West Virginia is exempt from federal and state taxes and will not pay or reimburse such taxes.
9. The Director of Purchasing may cancel any Purchase Order/Contract upon 30 days written notice to the seller.
10. The laws of the State of West Virginia and the *Legislative Rules* of the Purchasing Division shall govern the purchasing process.
11. Any reference to automatic renewal is hereby deleted. The Contract may be renewed only upon mutual written agreement of the parties.
12. **BANKRUPTCY:** In the event the vendor/contractor files for bankruptcy protection, the State may deem this contract null and void, and terminate such contract without further order.
13. **HIPAA BUSINESS ASSOCIATE ADDENDUM:** The West Virginia State Government HIPAA Business Associate Addendum (BAA), approved by the Attorney General, is available online at [www.state.wv.us/admin/purchase/vrc/hipaa.html](http://www.state.wv.us/admin/purchase/vrc/hipaa.html) and is hereby made part of the agreement provided that the Agency meets the definition of a Cover Entity (45 CFR §160.103) and will be disclosing Protected Health Information (45 CFR §160.103) to the vendor.
14. **CONFIDENTIALITY:** The vendor agrees that he or she will not disclose to anyone, directly or indirectly, any such personally identifiable information or other confidential information gained from the agency, unless the individual who is the subject of the information consents to the disclosure in writing or the disclosure is made pursuant to the agency's policies, procedures, and rules. Vendor further agrees to comply with the Confidentiality Policies and Information Security Accountability Requirements, set forth in <http://www.state.wv.us/admin/purchase/privacy/noticeConfidentiality.pdf>.
15. **LICENSING:** Vendors must be licensed and in good standing in accordance with any and all state and local laws and requirements by any state or local agency of West Virginia, including, but not limited to, the West Virginia Secretary of State's Office, the West Virginia Tax Department, and the West Virginia Insurance Commission. The vendor must provide all necessary releases to obtain information to enable the director or spending unit to verify that the vendor is licensed and in good standing with the above entities.
16. **ANTITRUST:** In submitting a bid to any agency for the State of West Virginia, the bidder offers and agrees that if the bid is accepted the bidder will convey, sell, assign or transfer to the State of West Virginia all rights, title and interest in and to all causes of action it may now or hereafter acquire under the antitrust laws of the United States and the State of West Virginia for price fixing and/or unreasonable restraints of trade relating to the particular commodities or services purchased or acquired by the State of West Virginia. Such assignment shall be made and become effective at the time the purchasing agency tenders the initial payment to the bidder.

I certify that this bid is made without prior understanding, agreement, or connection with any corporation, firm, limited liability company, partnership, or person or entity submitting a bid for the same material, supplies, equipment or services and is in all respects fair and without collusion or Fraud. I further certify that I am authorized to sign the certification on behalf of the bidder or this bid.

**INSTRUCTIONS TO BIDDERS**

1. Use the quotation forms provided by the Purchasing Division. Complete all sections of the quotation form.
2. Items offered must be in compliance with the specifications. Any deviation from the specifications must be clearly indicated by the bidder. Alternates offered by the bidder as **EQUAL** to the specifications must be clearly defined. A bidder offering an alternate should attach complete specifications and literature to the bid. The Purchasing Division may waive minor deviations to specifications.
3. Unit prices shall prevail in case of discrepancy. All quotations are considered F.O.B. destination unless alternate shipping terms are clearly identified in the quotation.
4. All quotations must be delivered by the bidder to the office listed below prior to the date and time of the bid opening. Failure of the bidder to deliver the quotations on time will result in bid disqualifications: Department of Administration, Purchasing Division, 2019 Washington Street East, P.O. Box 50130, Charleston, WV 25305-0130
5. Communication during the solicitation, bid, evaluation or award periods, except through the Purchasing Division, is strictly prohibited (W.Va. C.S.R. §148-1-6.6).

**WEST VIRGINIA STATE PARKS**  
Furniture Purchase  
Open End Contract

The West Virginia Division of Natural Resources, hereinafter Division, is requesting Bids for an open ended contract for the purchase of additional lodge room furniture to be utilized for upgrades and redecoration of facilities throughout the State. All items are to be F.O.B. Destination. Vendor must provide a bill of lading that clearly states actual shipping/delivery costs. The Division will reimburse the successful vendor for the actual shipping/delivery costs as stated on the vendor's bill of lading.

**General Specifications:**

Furniture must be manufactured for commercial hospitality use. All items must be new. Scheduling of shipping shall be coordinated between Division and Vendor.

**Information for Bidders:**

Bidders must submit a unit price Bid for each item. Bidders must bid on all items to be considered.

**Basis of Award:**

The Contract will be awarded to the lowest qualified Bidder submitting the lowest Bid for all furniture stipulated on the Bid schedule and in complete accordance with all specifications stipulated herein.

**Coordination:**

Vendor must coordinate shipping and receiving with each individual location.

**Delivery, Storage and Handling:**

The successful Vendor must deliver and handle all items according to Manufacturer's recommendations, including means and methods that will prevent damage, deterioration, and loss. Goods must be delivered in the Manufacturer's original sealed containers complete with labels and instructions for handling, storage, unpacking, protecting, and installing. The Division will supply labor to inspect the goods upon delivery, to ensure compliance with the purchase order, and to ensure all items are undamaged and protected against damage. All items must be delivered according to Manufacturer's recommendations and in an order that will facilitate inspection and measurement of quantity. All items must be delivered using means and methods that will prevent damage, deterioration, theft, or other loss.



WEST VIRGINIA STATE PARKS  
Furniture Purchase  
Open End Contract

**Damaged Items:**

All items will be inspected by the Division subsequent to delivery to ensure that each item is not damaged or defective. Damaged or defective items must be rejected, removed, and replaced at no additional expense to the Division.

**Project Closeout:**

Vendor must provide an inventory list of all items received and accepted. Vendor must provide the manufacturers recommendations for maintenance and cleaning.

**Applications for Payment:**

Vendor must submit an invoice upon receipt of all furniture delivered and accepted and upon completion of project closeout requirements.

**Warranty:**

The Vendor must warranty products to be free of defects in materials and Workmanship for a minimum period of one (1) year after date of acceptance or through manufacturer's provided warranty, whichever is greater. Vendor must repair or replace at its discretion, free of charge, any product that proves to be defective during the warranty period.

**Estimated Quantities:**

The quantities listed in this bid form are for bid evaluation purposes only – Actual quantities ordered may differ.

**Style of Furniture:**

The style of furniture chosen for this package is: TRANSITIONAL STYLE

Transitional style furniture is defined as a combination of both traditional and contemporary. The furniture features either straight lines or rounded profiles.

WEST VIRGINIA STATE PARKS  
Furniture Purchase  
Open End Contract

## General Furniture Construction Specifications:

### Construction:

- Joints must be mortised and tenoned, doweled or blocked glued and pinned.
- All corner blocks, braces and screw cleats must be glued and reinforced with staples, nails or screws.
- All corner blocks and braces must be made of solid wood.
- All structural members must be glued and screwed or stapled in place.
- Furniture must be surfaced with matching high-pressure laminate a minimum of .028" thickness that conforms to Federal Specification LP508H.
- Casters and base blocks must be glued and screwed allowing for free movement of the caster.

### Material:

- Exposed solid parts must be premium grade hardwood
- Unexposed solid parts must be select hardwoods.
- All panels must be cherry veneers
- All veneered panels must be constructed with waterproof glue under controlled pressure.
- Particleboard Standards
  1. All particle board must meet ANSI A208.1-1993.
  2. Tops with particleboard cores must be lumber banded on a minimum of three sides with edge banding on the back edges if they are not lumber banded.
  3. Cases must have no exposed particleboard.
  4. Particle board used in doors must be banded on all four sides.
- All items must be packed with packaging materials to minimize shipping damage.

### Workmanship:

- Cross grain sanding, machine marks, splits, chip outs, veneer checking, or roughness are not permitted on the surface of the finished product.
- All hardware including hinges, latches, catches and glides must be attached and fitted to operate properly and serve their purpose during transit and use.

WEST VIRGINIA STATE PARKS  
Furniture Purchase  
Open End Contract

- Miter joints must be square, flush, tight and well glued. Exposed case front joints must be tight not exceeding maximum of 1/64".
- Case tops must be attached to the case with screws allowing the top to be pulled down tight against the case.
- Interior screws must be flush or countersunk to the surface of the part where used.
- Assembly and hinge screws must be properly seated and driven flush with the hinge flange.
- All molding and overlays must be nailed from the back of the panel if possible. Face nails or brads are driven flush or set and nail holes filled.

**Appearance and Finish:**

Finishing must meet the following specifications:

- Color of like finishes must be color-fast, uniform, and compatible between pieces manufactured in the plant
- Color must match selection specified in furniture specifications
- Each finishing material must be formulated and individual batches checked to insure compatibility with the batch and every other material used to produce a color-fast finishing system.
- Interior surfaces of compartments and drawers must be free of dirt, dust, shavings or any foreign matter prior to finishing.
- Finish must be rubbed to required smoothness and sheen and dried to prevent marring or printing on the surface when packed.
- Edges and backs of doors and drawers finished must be compatible with exterior.
- Excess pumice, oil, wax and rubbing compound must be wiped clean after rubbing.

**Performance:**

- Hardware, both trim and functional, must be straight and firmly attached.

**Furniture Specifications:**

Items for this bid must meet these minimum specifications. Construction, color, hardware, and finish selections must meet the minimum specifications as set forth above.

WEST VIRGINIA STATE PARKS  
Furniture Purchase  
Open End Contract

**WALL HUNG TWIN HEADBOARD** – Must match Thomasville Changeables 5640 & 5660, or equal.

- Must be made to maximum dimensions of: 40"W x 1 1/8"D x 36" H
- Must match attached drawing – Wall Hung Headboard
- Finish must be light cherry (and must match existing furniture finish - 8582)

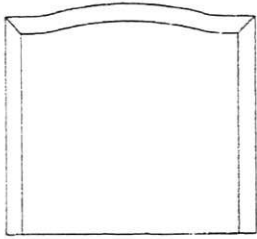

**FREE STANDING TWIN HEADBOARD** - Must match Thomasville "Changeables" Collection 5640 & 5660, or equal.

- Must be made to maximum dimensions of: 40"W x 1 1/8"D x 36"
- Must include heavy duty metal frame with mounting hardware for frame and headboard and carpet wheels
- Must match attached drawing 8582 Wall Hung Headboard
- Finish must be light cherry (and must match existing furniture finish - 8582)

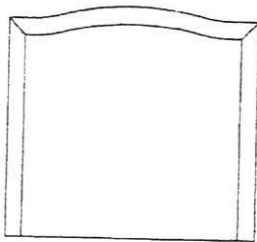

**FINISHED LEG KIT**

- Maximum dimensions must be 3"W x 1"D x 33" H
- Must have two finished posts
- Must have (6) minimum 1 1/8" Pan head screws included
- Must match attached drawing 8582 Wall Hung Headboard
- Finish must be light cherry (and must match existing furniture finish - 8582)

WEST VIRGINIA STATE PARKS  
Furniture Purchase  
Open End Contract

**RECTANGULAR TABLE / DESK** – Must match Thomasville “Changeables” Collection Table, or equal

- Must be made to maximum dimensions of 44”Wx 22”D x 30”H
- Apron to floor maximum length must be 26 ¼”
- Must have lumber banded laminate top
- Must have KD construction
- Must match attached drawing 8582 Table
- Finish must be light cherry (and must match existing furniture finish – 8582)
- Must match Thomasville “Changeables” MOULDING-50-D

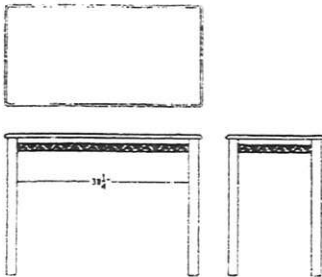

**BOOKCASE** – Must match Thomasville “WorkStyles” Collection 50841-802c, or equal

- Must be made to maximum dimensions of 34 ½” W x 17”D x 79 ½” H
- Minimum Six shelves
- Minimum three of six shelves must be adjustable (Shelves 1, 3 and 5 to be adjustable)
- Finish must be light cherry (and must match existing furniture finish - 8582)

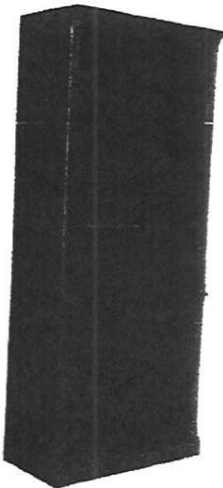

WEST VIRGINIA STATE PARKS  
Furniture Purchase  
Open End Contract

**QUEEN STEEL BED BASES**

- Must be minimum 6" to surface
- Must have minimum of three tubular cross supports and inner legs
- Must be steel construction – noncombustible material

**ROUND DINING TABLE and BASE – Thomasville" Color Café" Selection, TAB5400 or Equal**

- Minimum dimensions must be 54" Diameter x 30" High
- Must have solid top
- Must seat a minimum of six
- Must match attached drawing
- Top finish specified should be: (28) Amaretto Washed, Matte Finish
- Body finish specified should be: (05) Peppercorn
- Final body and top finish will be selected from Manufacturer's standard finish selections that are similar to above selections

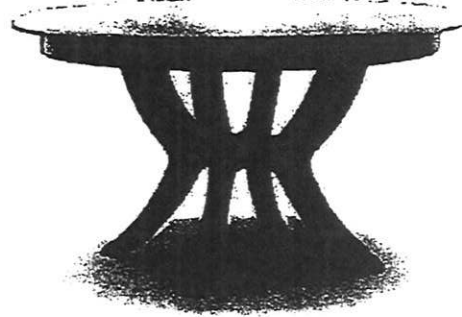

**SIDE CHAIR #1 – Thomasville Color "Café Selection", CHA1258 or Equal**

- Minimum dimensions must be 18"W x 20"D x 40"H
- Minimum seat height must be 18"
- All wood
- Must match attached drawing
- Body finish selected: (05) Peppercorn
- Seat finish selected: (28) Amaretto Washed
- Final body and top finish will be selected from Manufacturer's standard finish selections that are similar to above selections



WEST VIRGINIA STATE PARKS  
Furniture Purchase  
Open End Contract

**RECTANGULAR DINING TABLE** – Thomasville “Color Café” Selection, TAB3611 or Equal

- Minimum dimensions must be 48” – 60” L x 36”W x 30”H
- Must have maximum of one leaf for expansion of table
- Must seat a minimum of six
- Must match attached drawing
- Top finish selected: (28) Amaretto, Matte Finish
- Body finish selected: (28) Amaretto, Matte Finish
- Final body and top finish will be selected from Manufacturer’s standard finish selections that are similar to above selections

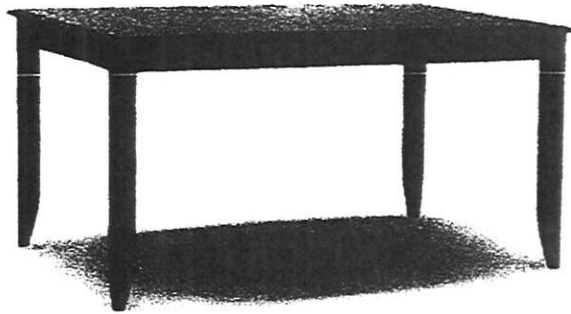

**SIDE CHAIR #2** – Thomasville “Color Café” Selection, CHA1258 or Equal

- Minimum dimensions must be 18”W x 20”D x 40”H
- Minimum seat height must be 18”
- All wood
- Must match attached drawing
- Body finish selected: (28) Amaretto, Matte Finish
- Seat finish selected: (28) Amaretto, Matte Finish
- Final body and top finish will be selected from Manufacturer’s standard finish selections that are similar to above selections

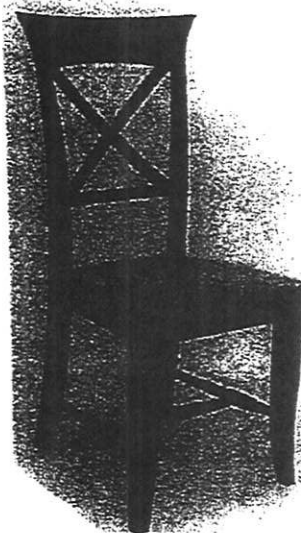

## MANUFACTURER LIST

Item No.	Description	Manufacturer / Model #
1	WALL HUNG TWIN HEADBOARD	Thomasville/8582-CT1110
2	FREE STANDING TWIN HEADBOARD	Thomasville/8582-CT1110
3	FINISHED LEG KIT	Thomasville/8582-044
4	RECTANGULAR TABLE / DESK	Thomasville/8582-CT1104
5	BOOKCASE	Thomasville/50841-802C
6	QUEEN STEEL BED BASE	Thomasville/0132-0140
7	ROUND DINING TABLE AND BASE	Thomasville/TAB054002805MSI1F Thomasville/BAS05400NA05MSI
8	SIDE CHAIR #1	Thomasville/CHA012582805MNN
9	RECTANGULAR DINING TABLE	Thomasville/TAB036112828MEE1
10	SIDE CHAIR #2	Thomasville/CHA012582828MNN



**BID FORM - FURNITURE**

*THE QUANTITIES LISTED  
BELOW ARE FOR BID  
EVALUATION PURPOSES ONLY.  
ACTUAL QUANTITIES MAY  
DIFFER*

Item No.	Estimated Quantity	Description	Unit Price	Total Amount
1	26	WALL HUNG TWIN HEADBOARD	\$232.99	\$ 6,057.74
2	10	FREE STANDING TWIN HEADBOARD	\$238.64	\$ 2,386.40
3	22	FINISHED LEG KIT	\$ 41.19	\$ 906.18
4	53	RECTANGULAR TABLE / DESK	\$231.58	\$12,273.74
5	1	BOOKCASE	\$563.56	\$ 563.56
6	99	QUEEN STEEL BED BASE	\$ 100.45	\$ 9,944.55
7	5	ROUND DINING TABLE AND BASE	\$1,402.93	\$ 7,014.65
8	20	SIDE CHAIR #1	\$ 304.60	\$ 6,092.00
9	1	RECTANGULAR DINING TABLE	\$ 720.25	\$ 720.25
10	6	SIDE CHAIR #2	\$ 304.60	\$ 1,827.60
<b>TOTAL</b>				<b>\$ 47,786.67</b>

*THE QUANTITIES LISTED ABOVE  
ARE FOR BID EVALUATION  
PURPOSES ONLY. ACTUAL  
QUANTITIES MAY DIFFER*

# State of West Virginia

## VENDOR PREFERENCE CERTIFICATE

Certification and application\* is hereby made for Preference in accordance with **West Virginia Code**, §5A-3-37. (Does not apply to construction contracts). **West Virginia Code**, §5A-3-37, provides an opportunity for qualifying vendors to request (at the time of bid) preference for their residency status. Such preference is an evaluation method only and will be applied only to the cost bid in accordance with the **West Virginia Code**. This certificate for application is to be used to request such preference. The Purchasing Division will make the determination of the Resident Vendor Preference, if applicable.

1. **Application is made for 2.5% resident vendor preference for the reason checked:**  
 \_\_\_\_\_ Bidder is an individual resident vendor and has resided continuously in West Virginia for four (4) years immediately preceding the date of this certification; or,  
 \_\_\_\_\_ Bidder is a partnership, association or corporation resident vendor and has maintained its headquarters or principal place of business continuously in West Virginia for four (4) years immediately preceding the date of this certification; or 80% of the ownership interest of Bidder is held by another individual, partnership, association or corporation resident vendor who has maintained its headquarters or principal place of business continuously in West Virginia for four (4) years immediately preceding the date of this certification; or,  
 \_\_\_\_\_ Bidder is a nonresident vendor which has an affiliate or subsidiary which employs a minimum of one hundred state residents and which has maintained its headquarters or principal place of business within West Virginia continuously for the four (4) years immediately preceding the date of this certification; or,
2. **Application is made for 2.5% resident vendor preference for the reason checked:**  
 \_\_\_\_\_ Bidder is a resident vendor who certifies that, during the life of the contract, on average at least 75% of the employees working on the project being bid are residents of West Virginia who have resided in the state continuously for the two years immediately preceding submission of this bid; or,
3. **Application is made for 2.5% resident vendor preference for the reason checked:**  
 \_\_\_\_\_ Bidder is a nonresident vendor employing a minimum of one hundred state residents or is a nonresident vendor with an affiliate or subsidiary which maintains its headquarters or principal place of business within West Virginia employing a minimum of one hundred state residents who certifies that, during the life of the contract, on average at least 75% of the employees or Bidder's affiliate's or subsidiary's employees are residents of West Virginia who have resided in the state continuously for the two years immediately preceding submission of this bid; or,
4. **Application is made for 5% resident vendor preference for the reason checked:**  
 \_\_\_\_\_ Bidder meets either the requirement of both subdivisions (1) and (2) or subdivision (1) and (3) as stated above; or,
5. **Application is made for 3.5% resident vendor preference who is a veteran for the reason checked:**  
 \_\_\_\_\_ Bidder is an individual resident vendor who is a veteran of the United States armed forces, the reserves or the National Guard and has resided in West Virginia continuously for the four years immediately preceding the date on which the bid is submitted; or,
6. **Application is made for 3.5% resident vendor preference who is a veteran for the reason checked:**  
 \_\_\_\_\_ Bidder is a resident vendor who is a veteran of the United States armed forces, the reserves or the National Guard, if, for purposes of producing or distributing the commodities or completing the project which is the subject of the vendor's bid and continuously over the entire term of the project, on average at least seventy-five percent of the vendor's employees are residents of West Virginia who have resided in the state continuously for the two immediately preceding years.

Bidder understands if the Secretary of Revenue determines that a Bidder receiving preference has failed to continue to meet the requirements for such preference, the Secretary may order the Director of Purchasing to: (a) reject the bid; or (b) assess a penalty against such Bidder in an amount not to exceed 5% of the bid amount and that such penalty will be paid to the contracting agency or deducted from any unpaid balance on the contract or purchase order.

By submission of this certificate, Bidder agrees to disclose any reasonably requested information to the Purchasing Division and authorizes the Department of Revenue to disclose to the Director of Purchasing appropriate information verifying that Bidder has paid the required business taxes, provided that such information does not contain the amounts of taxes paid nor any other information deemed by the Tax Commissioner to be confidential.

Under penalty of law for false swearing (**West Virginia Code**, §61-5-3), Bidder hereby certifies that this certificate is true and accurate in all respects; and that if a contract is issued to Bidder and if anything contained within this certificate changes during the term of the contract, Bidder will notify the Purchasing Division in writing immediately.

Bidder: \_\_\_\_\_ Signed: \_\_\_\_\_

Date: \_\_\_\_\_ Title: \_\_\_\_\_

\*Check any combination of preference consideration(s) indicated above, which you are entitled to receive.

RFQ No. DNRB12101

STATE OF WEST VIRGINIA  
Purchasing Division

**PURCHASING AFFIDAVIT**

West Virginia Code §5A-3-10a states: No contract or renewal of any contract may be awarded by the state or any of its political subdivisions to any vendor or prospective vendor when the vendor or prospective vendor or a related party to the vendor or prospective vendor is a debtor and the debt owed is an amount greater than one thousand dollars in the aggregate.

**DEFINITIONS:**

"Debt" means any assessment, premium, penalty, fine, tax or other amount of money owed to the state or any of its political subdivisions because of a judgment, fine, permit violation, license assessment, defaulted workers' compensation premium, penalty or other assessment presently delinquent or due and required to be paid to the state or any of its political subdivisions, including any interest or additional penalties accrued thereon.

"Debtor" means any individual, corporation, partnership, association, limited liability company or any other form or business association owing a debt to the state or any of its political subdivisions. "Political subdivision" means any county commission; municipality; county board of education; any instrumentality established by a county or municipality; any separate corporation or instrumentality established by one or more counties or municipalities, as permitted by law; or any public body charged by law with the performance of a government function or whose jurisdiction is coextensive with one or more counties or municipalities. "Related party" means a party, whether an individual, corporation, partnership, association, limited liability company or any other form or business association or other entity whatsoever, related to any vendor by blood, marriage, ownership or contract through which the party has a relationship of ownership or other interest with the vendor so that the party will actually or by effect receive or control a portion of the benefit, profit or other consideration from performance of a vendor contract with the party receiving an amount that meets or exceeds five percent of the total contract amount.

**EXCEPTION:** The prohibition of this section does not apply where a vendor has contested any tax administered pursuant to chapter eleven of this code, workers' compensation premium, permit fee or environmental fee or assessment and the matter has not become final or where the vendor has entered into a payment plan or agreement and the vendor is not in default of any of the provisions of such plan or agreement.

Under penalty of law for false swearing (*West Virginia Code §61-5-3*), it is hereby certified that the vendor affirms and acknowledges the information in this affidavit and is in compliance with the requirements as stated.

**WITNESS THE FOLLOWING SIGNATURE**

Vendor's Name: THOMASVILLE FURNITURE IND., INC.

Authorized Signature: *[Signature]* Date: 3/16/12

State of VIRGINIA

County of JAMES CITY, to-wit:

Taken, subscribed, and sworn to before me this 16 day of March, 2012.

My Commission expires 31 July, 2016

AFFIX SEAL HERE

NOTARY PUBLIC *[Signature]*

Commonwealth Of Virginia  
Cheryl Lynn Wheeler - Notary Public  
Commission No. 7511027  
My Commission Expires 7/31/2016

PAIGE VIA  
Government Sales Representative:  
Eastern Shore-Wallops Island, VA, DC, DE, MD  
NC, SC, WV, Guantanamo Bay, Cuba, Central &  
So. America, & Puerto Rico.  
www.contract.thomasville.com

105 Holman Road  
Williamsburg, VA 23185-5552  
Tel: 757.565.2145  
Fax: 757.565.9623  
Cell: 757.784.3015  
Email: MPaigeVia@gmail.com

**STATE OF WEST VIRGINIA, CHARLESTON, WV  
DNRB12101**

**FOB: DESTINATION**

ITEM #	QTY	MODEL #	DESCRIPTION	GSA PRICE	GSA COST EXTENSION
1	26	8582-CT1110	Wall Hung Twin Headboard, 40"W x 1-1/8"D x 36"H to match 8582-5640 & 5660 Changeables Select, Light Cherry Finish (Blackwater Falls)	\$232.99	\$6,057.74
2	10	8582-CT1110	Free Standing Twin Headboard, 40"W x 1-1/8"D x 36"H to match 8582-5640 & 5660 (The Inn at Cacapon)	\$238.64	\$2,386.40
3	22	8582-044	Finished Leg Kit, 3"W x 1"D x 33"H 2 Finished Posts & (6) 1-7/8" Pan Head Screws Included (The Inn at Cacapon)	\$41.19	\$906.18
4	53	8582-CT1104	Rectangular Table/Desk, 44" W x 22"D x 30"H Apron to Floor: 26-1/4"; 50D Moulding Lumber Banded Laminate Top, KD Construction Changeables Select, Light Cherry Finish (Blackwater Falls)	\$231.58	\$12,273.74
5	1	50841-802c	Bookcase, 34-1/2"W x 17"D x 79-1/2"H From top: 6 Shelves (Nos. 1,3 & 5 Shelves adjustable) Refinish in Cherry Stain (Pipestem)	\$563.56	\$563.56
6	99	0132-0140	Queen Steel Bed Base, 6" to Surface (Pipestem)	\$100.45	\$9,944.55
7	5 5	TAB054002805MSI1F BAS05400NA05MSI	Round Dining Table and Base, 54" Diameter x 30"H Solid Top, Top Finish: 28:Amaretto Washed Body Finish: 05: Peppercorn Washed Matte Finish, Seats 6. Fixed/Solid Top (NO LEAVES) (This is a 2-Part item. Must order both SKU #'s) (Business Center-Main Lodge-Pipestem)	\$1,402.93 Included	\$7,014.65

Terms: Net 30  
FOB:Destination

8	20	CHA012582805MNN	Side Chair #1, 18"W x 20"D x 40"H Body Finish: 05 Peppercorn Washed Seating Finish: 28 Amaretto Washed (Business Center-Main Lodge-Pipestem)	\$304.60	\$6,092.00	
9	1	TAB036112828MEE1	Rectangular Dining Table, 48"-60"L x 36"W x 30"H 1 Leaf, Seats 6 (Suite 119-Pipestem)	\$720.25	\$720.25	
10	6	CHA012582828MNN	Side Chair #2, 18"W x 20"D x 40"H Body Finish: 28 Amaretto Washed Seating Finish: 28 Amaretto Washed (Suite 119-Pipestem)	\$304.60	\$1,827.60	
<b>Subtotal</b>						<b>\$47,786.67</b>
<b>Grand Total</b>						<b>\$47,786.67</b>

**ORDERING ADDRESS:**

THOMASVILLE FURNITURE IND. INC.  
P.O. BOX 339  
THOMASVILLE, NC 27361  
ATTN: JOYCE HILL-CUSTOMER SERVICE  
PHONE: (336)472-4044  
FAX: (336)476-2262  
EMAIL: JHILL@THOMASVILLE.COM

**REMITTANCE ADDRESS:**

THOMASVILLE FURNITURE IND. INC  
P.O. BOX 536904  
ATLANTA, GA 30353

FOB POINT: THOMASVILLE, NC

PAYMENT TERMS: NET 30

BUSINESS SIZE: LARGE BUSINESS

CAGE CODE: 59852

CEC: 00-4229-71C

DUNS NO: 00-3219-615

FED TAX ID NO: 56-0906-574

NAVY BPA NO: N00189-11-A-0052

NAICS CODE: 337125-337121

AF BPA: FA4452-11-A-0004

AF NPA CONTRACT: F41999-09-D-0035

HOUSEHOLD &amp; QUARTER FURNITURE &amp; PACKAGED ROOM # GS-27E-0013J

COMPREHENSIVE FURNITURE MANAGEMENT SERVICES #GS-29F-0014U



*Item #7, TAB054002805MSI1F &  
BAS05400NA28MSI,  
Round Dining Table & Base*



*Item #8, CHA012582805MNN, Side Chair*



*Item #9, TAB036112828MEE1,  
Rectangular Dining Table*



*Item #10, CHA012582828MNN, Side Chair*

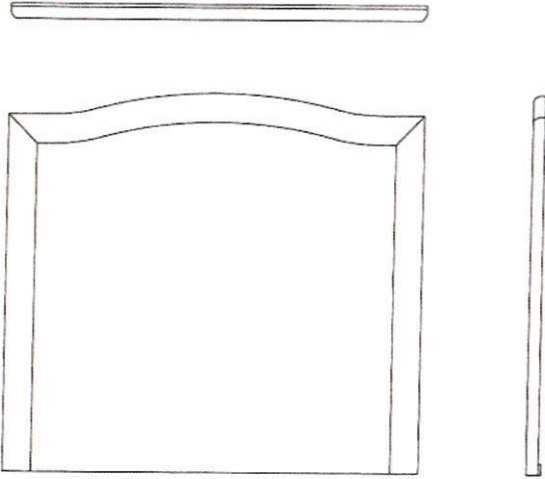

Item #1, 8582-CT1110, Wall Hung Twin Headboard (Blackwater Falls)

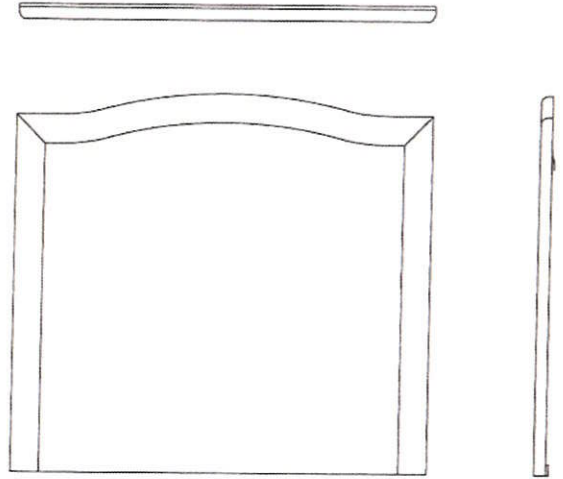

Item #2, 8582-CT1110, Free Standing Twin Headboard (The Inn at Cacapon)



Item #3, 8582-044, Finished Leg Kit (The Inn at Cacapon)

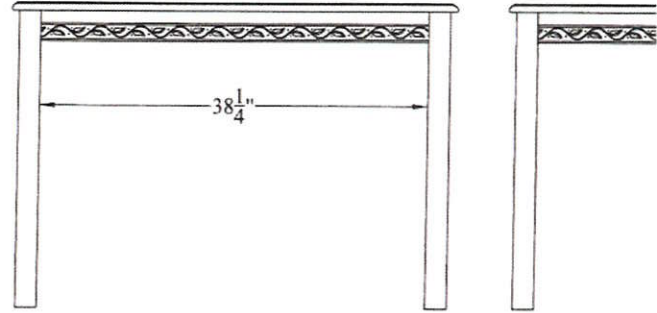

Item #4, 8582-CT1104, Rectangular Table/Desk (Blackwater Falls)

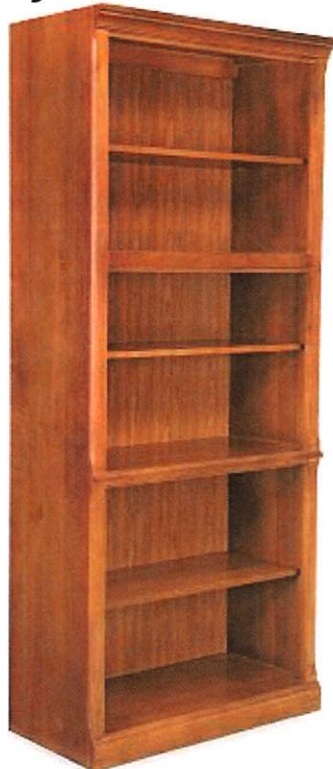

Item #5, 50841-802C, Bookcase  
Picture is of Newbridge Finish. To be finished in Light Cherry Finish (Pipestem)

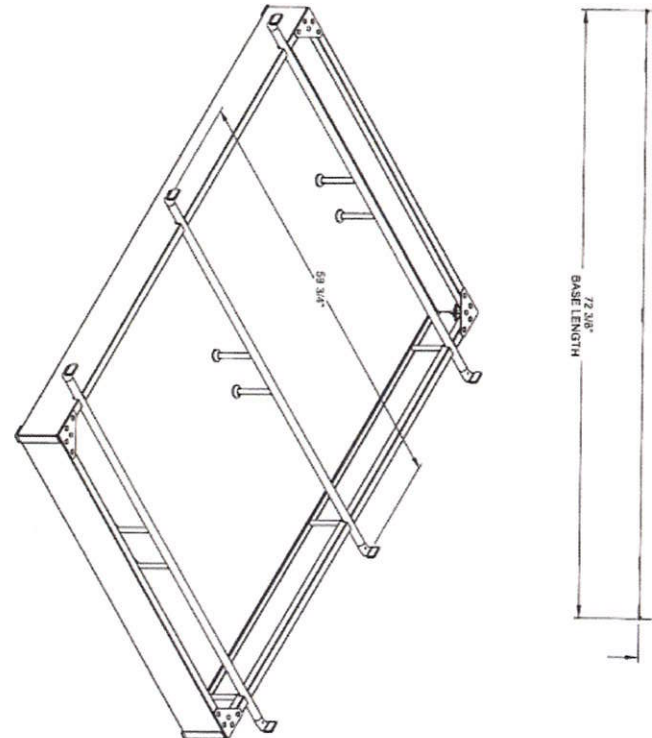

Item #6, 0132-0140, Queen Steel Bed Base (Pipestem)-See Specifications sheets

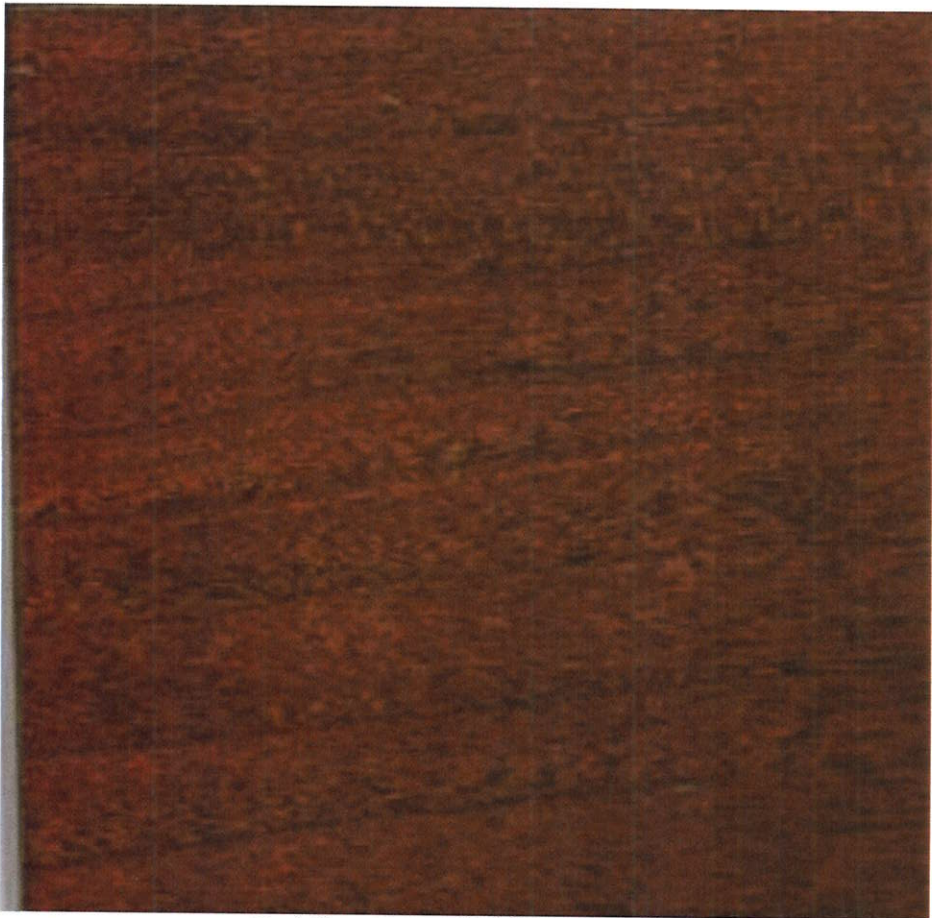

*Bridges Newbridge Finish*

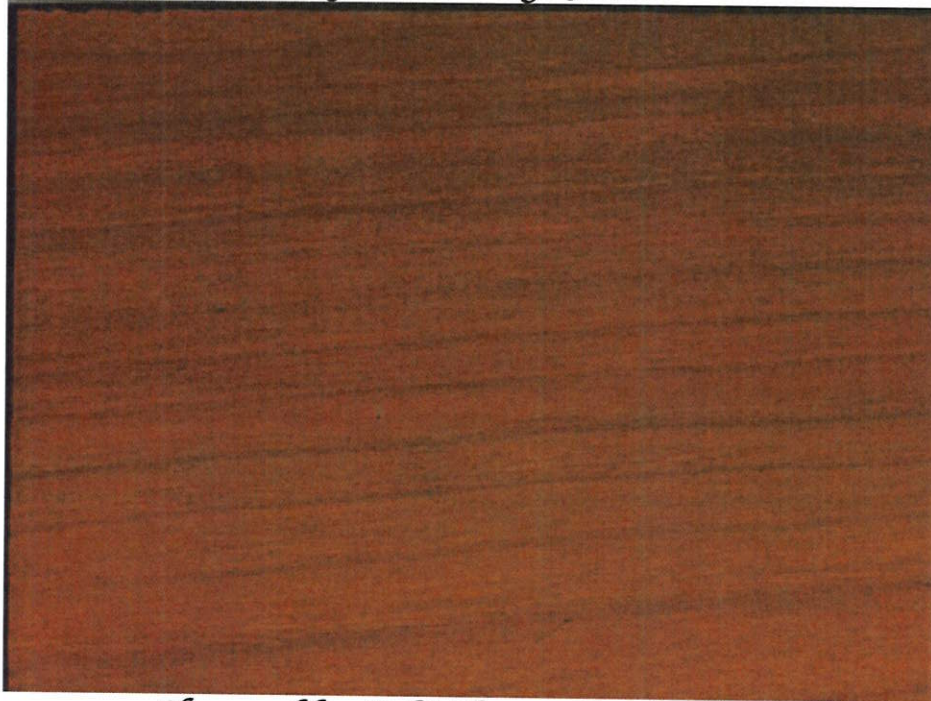

*Changeables Light Cherry Finish, 8582*



Thomasville Furniture Industries  
Custom Product

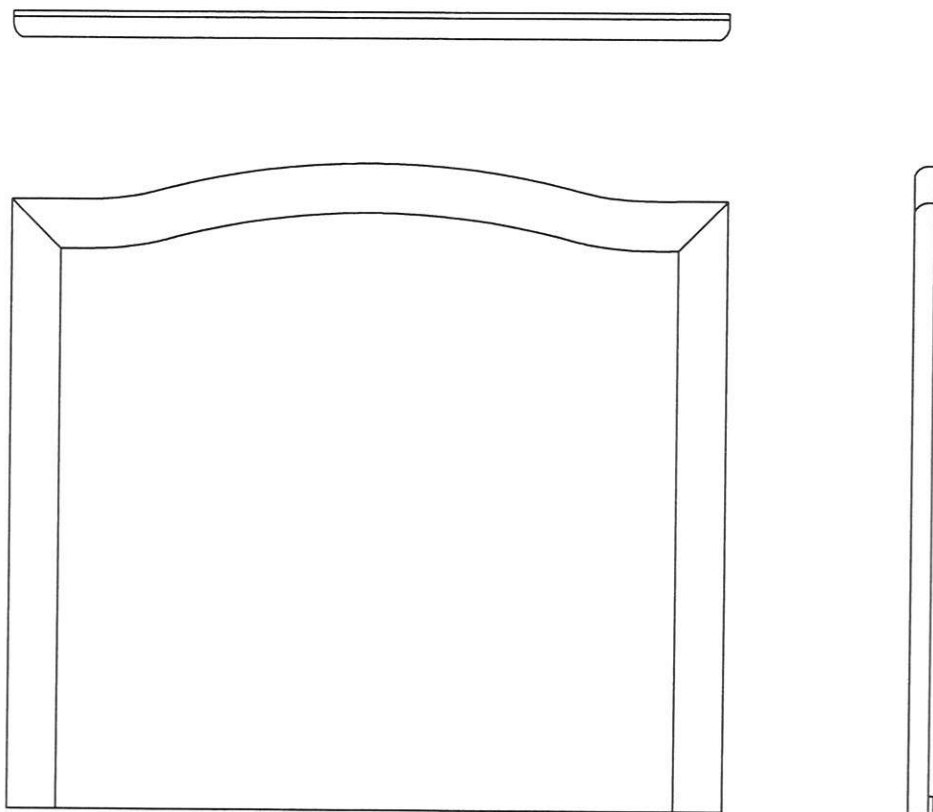

8582 Wall Hung Headboard - Twin (3/3)

40" W x 1-1/8" D x 36" H  
Wall Hung

Via: E-22243  
Blackwater Falls State Park; WV

CT1110  
Estimated Weight (lbs): 45  
Estimated Cubes (cu '): 3.6

Suite: Changeables  
Finish: Light Cherry  
Species: Cherry Veneers, Select Hardwoods.

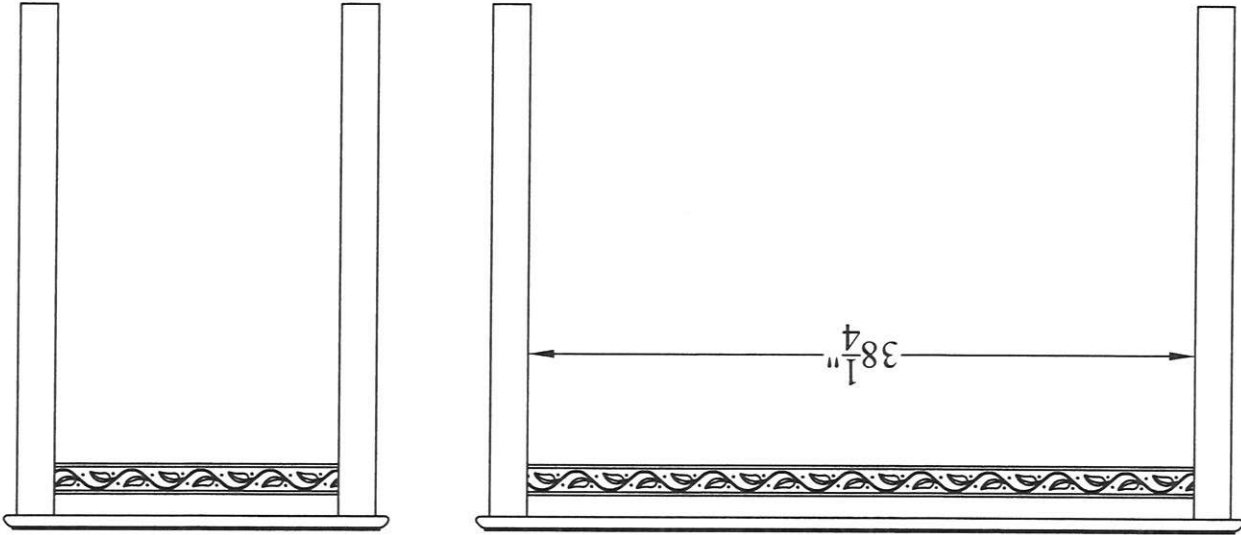
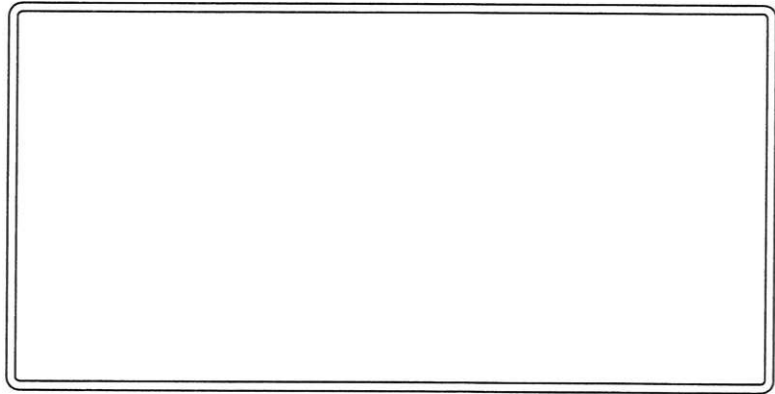

8582 Table

Suite: Changeables  
Finish: 8582 Light Cherry  
Cherry Veneers and Select Hardwood Solids  
50D Molding

44" W x 22" D x 30" H  
Lumber Banded Laminate Top, KD Construction.  
Apron to Floor: 26-1/4"

Via: E-22217  
Blackwater Falls State Park, West Virginia

CT1104  
Estimated Weight (lbs): 41  
Estimated Cubes (cu ): 4.7

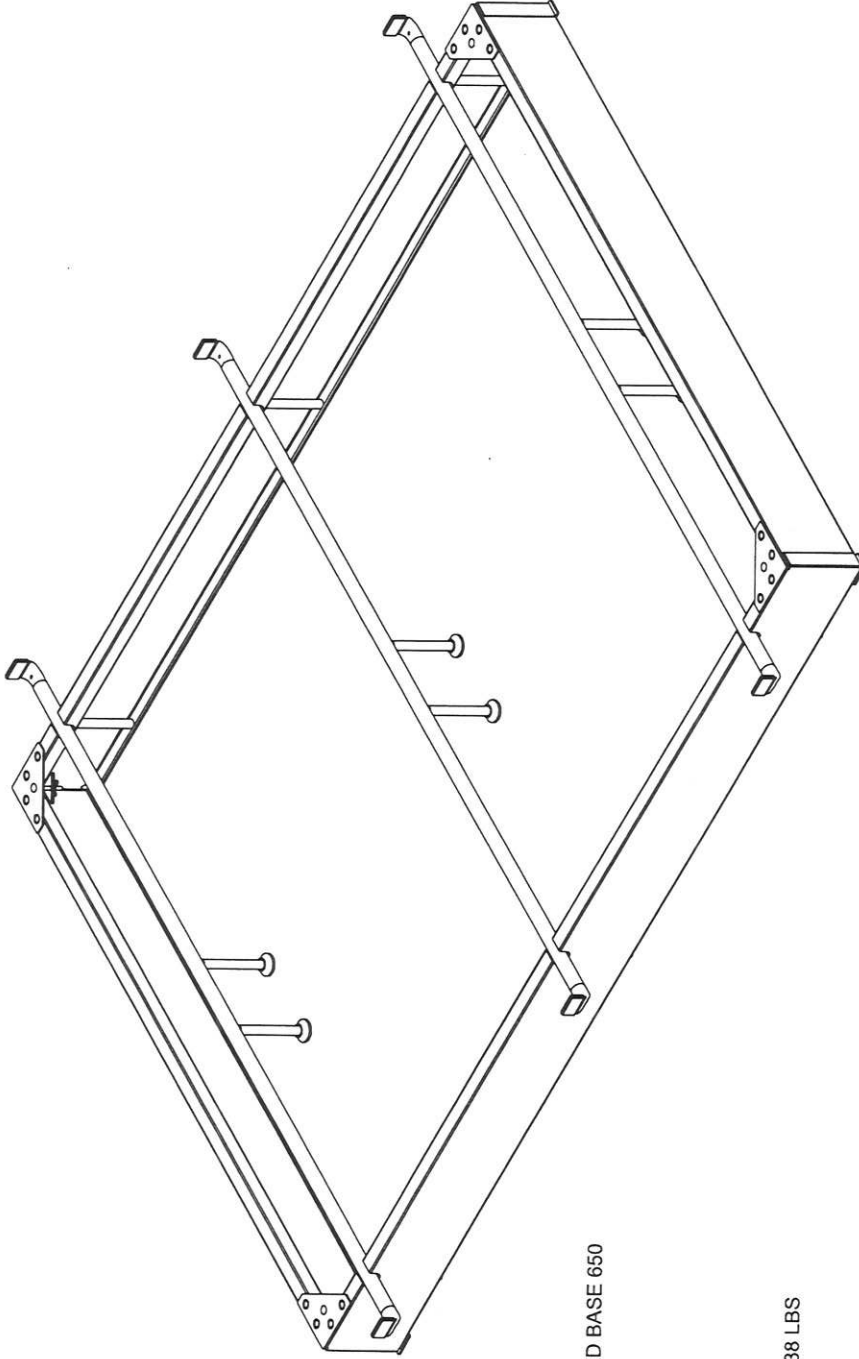

**PRODUCT:** PEDESTAL BED BASE 650

**GENERAL**

**APPLICATION:** QUEEN

**FINISH:** BROWN

**PACKAGED WEIGHT:** 38 LBS

**UPC CODE:** N/A

**CONSTRUCTION**

**SIDE RAIL:** .033 ROLL FORMED STEEL

**END RAIL:** .033 ROLL FORMED STEEL

**SLAT:**  $\phi$ 1" X 18 GA. STEEL TUBING

**LEG:**  $\phi$ 5/8" X 18 GA. STEEL TUBING

**RETAINER BRACKETS:** N/A

**HEADBOARD/FOOTBOARD BRACKETS:** N/A

**REMARKS:**

ALL FASTENERS PER ANSI B19 AND SAE J429 STANDARDS ALL WELDS PER ANSIS/AWS A2.4.79 AMERICAN NATIONAL STANDARD		DIMENSIONS ARE INCHES UNLESS OTHERWISE NOTED		TOLERANCE UNLESS OTHERWISE NOTED		DECIMAL: .XXX = $\pm$ .015 .XX = $\pm$ .03 .X = $\pm$ .06		FRACTIONAL: $\pm$ 1/32 $\pm$ 1"		ANGULAR: $\pm$ 1°		PROPRIETARY AND CONFIDENTIAL THE INFORMATION CONTAINED IN THIS DRAWING IS THE SOLE PROPERTY OF LEGGETT & PLATT, INC. REPRODUCTION IN PART OR AS A WHOLE WITHOUT THE WRITTEN PERMISSION OF LEGGETT & PLATT, INC. IS PROHIBITED.	
C	1) REPLACES 21770095 (SHT 2)	JNM	RAB	10641	1/15/08	*REV B ON EDR 10474*		REV. LEVEL APPROVALS DRAWN ENGINEERING TOOLING MFG APPR. C.A.		NAME N/A N/A N/A N/A N/A		DATE N/A N/A N/A N/A N/A	
1) REPLACES 21770095 (SHT 2)								AUTHOR 		CHKD 		EDR#	
PEDESTAL BED BASE, QUEEN, 650 BROWN								SIZE DWG. NO. <b>571080</b>		SCALE: 1:12		DO NOT SCALE DRAWING	
DESTROY ALL PRINTS ISSUED PRIOR TO THIS REVISION													

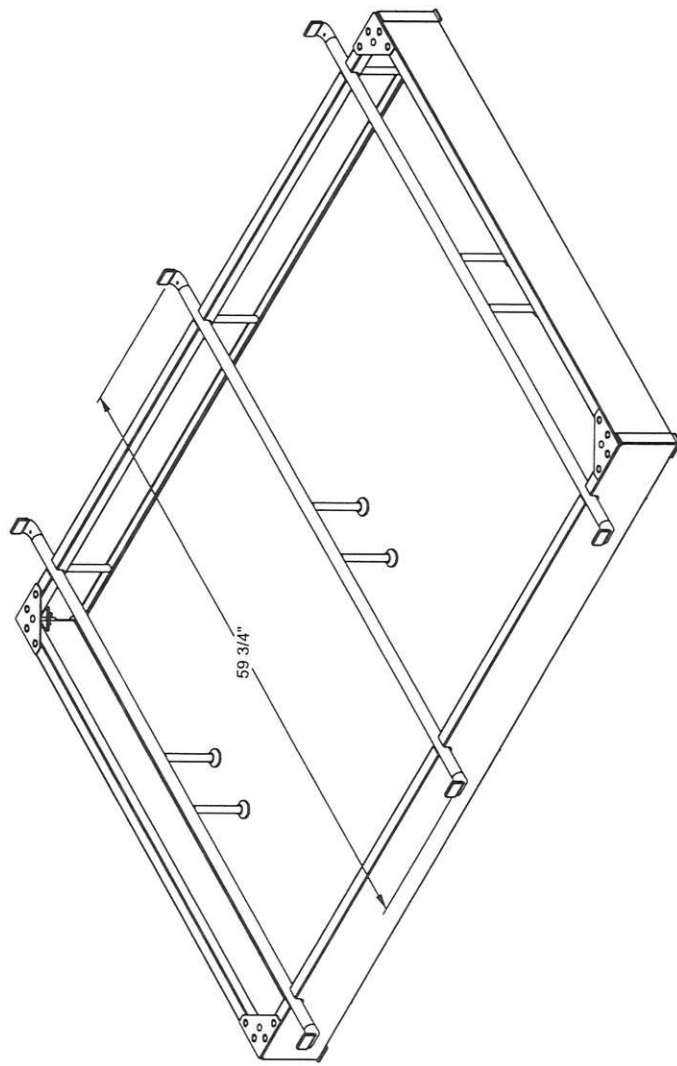
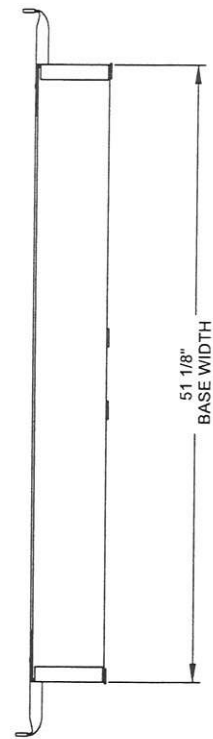
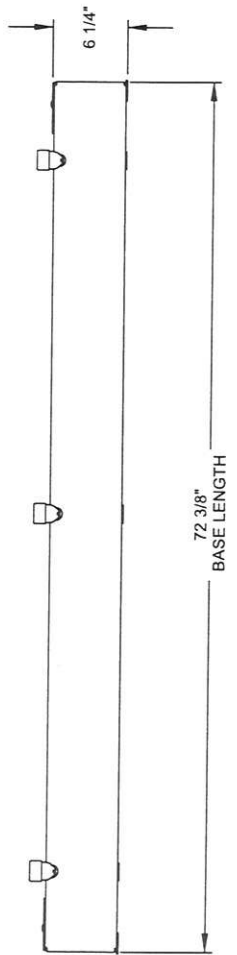

ALL FASTENERS PER ANSI B19 AND SAE J429 STANDARDS  
 ALL WELDS PER ANSI AWS A2.4-79 AMERICAN NATIONAL STANDARD

DIMENSIONS ARE INCHES UNLESS OTHERWISE NOTED

TOLERANCE UNLESS OTHERWISE NOTED

DECIMAL	FRACTIONAL	ANGULAR
+0.0000	± 1/32	± 1°
-0.0000	± 1/32	± 1°

PROPRIETARY AND CONFIDENTIAL  
 THE INFORMATION CONTAINED IN THIS DRAWING IS THE SOLE PROPERTY OF WILCOX & HALEY, INC. ANY REPRODUCTION OR TRANSMISSION WITHOUT THE WRITTEN PERMISSION OF WILCOX & HALEY, INC. IS PROHIBITED.

C	1) REPLACES 21770096 (SHEET 2)	JAN	RAB	10841	11/15/08
	"REV B ON EDR 10474"				
REV. LEVEL	DESCRIPTION	DATE	NAME	DATE	DATE
APPROVALS					
DRAWN	N/A	N/A			
ENGINEERING	N/A	N/A			
WORKING	N/A	N/A			
MFG APPR	N/A	N/A			
G.A.	N/A	N/A			

AUTHOR: *Bob Applegate*

PEDESTAL BED BASE,  
 QUEEN, 650 BROWN

SCALE: DWG. NO. 571080  
 SHEET B OF B  
 SCALE: 1:10 | DO NOT SCALE DRAWING | SHEET 3 OF 3

## **Item # 6, 0132-0140 Queen Steel Bed Base (Pipestem)**

### **Why Leggett & Platt**

Leggett & Platt® introduced the steel coil bedspring more than 125 years ago, and continues to be the sleep industry's leading innovator by listening to consumers and investing in research and development. Our products are trusted the industry over, and we supply and service countless hotels and other institutional markets.

Leggett & Platt is the leading supplier of a wide range of products and components for the home, including: mattress springs, pocketed coils, power foundations, bed frames, ornamental beds, bedding accessories, carpet cushion, and much more. With more than one century of experience in creating comfortable sleep surfaces, Leggett & Platt can claim an uncommon level of expertise in helping people sleep better. We stand proudly behind our quality and look forward to another 100 years of serving you.

## Changeables Select

### Changeables Select

#### Finishes and Species Options







B56C Washed Sand (Oak Veneers, Ash Hardwoods)  
 B562 Light Cherry (Okume Veneers, Select Hardwoods)  
 B563 Dark Mahogany (Okume Veneers, Select Hardwoods)  
 B564 Natural Oak (Oak Veneers, Ash Hardwoods)

#### Molding Options



20A   
 30B   
 40C   
 50D 



#### Hardware Options

W42 (Dark Antique Brass Finish)    
 W52 (Black Iron Finish)    
 W62 (Antique Copper Finish)    
 W72 (Black Iron Finish) 

#### Base Options

1021   
 1031   
 1041 

Please specify Finish, Hardware, Molding and Base styles when ordering.

#### Construction

Lumber Banded High Pressure Laminate Tops  
 Plywood Drawer Box with Ball Bearing B Side Guides

### Light Cherry 8582/8572



Example shown above:  
 Moulding: Mould40C  
 Base: 1021  
 Hardware: Hard W72  
 Finish: Light Cherry

#### Bases (shown in Light Cherry)



Base 1021



Base 1031



Base 1041

#### Mouldings (shown in Light Cherry)



Mould20A



Mould30B



Mould40C



Mould50D

## Changeables

(Particle Board Core Version)

8580 Washed Sand Finish (Oak Veneers, Ash Hardwoods)

8582 Light Cherry Finish (Cherry Veneers, Select Hardwoods)

8583 Dark Mahogany Finish (Cherry Veneers, Select Hardwoods)

8584 Natural Oak Finish (Oak Veneers, Ash Hardwoods)



8582-3520 Three Drawer Chest  
36" W x 22" D x 30" H

### Features

- 1) High Pressure Laminate Top.
- 2) Lumber Banded Top Edge Treatment with Pre-Catalyzed Lacquer Top Coat.
- 3) Hardwood Veneers and Select Hardwood Solids.
- 4) 8 Step Finish with a Pre-Catalyzed Lacquer Top Coat.
- 5) 7/16" Thick Baltic Birch Plywood Drawer Box with English Dovetails and a 3/16" Veneered Plywood Drawer Bottom with a UV Cured Top Coat.
- 6) 75 lbs. Rated 3/4 Extension Ball Bearing Side Guides.
- 7) 1/8" Hardboard Back Panel.
- 8) Recessed Back Panel.
- 9) PVC Edge Banding on all bottom edges.

### Benefits

- 1) Prevents scratches and resists moisture.
- 2) Highly durable and resists water.
- 3) Meets brand specifications requiring veneered product.
- 4) Highly durable finish which resists water and cleaning solutions.
- 5) Moisture resistant drawers and meets most brand specifications.
- 6) Well fitted, longer lasting drawers with minimal side to side movement.
- 7) Exposed back panel finish compliments the case finish.
- 8) Allows case to be placed flush against walls without interfering with electrical cords.
- 9) Helps prevent moisture from penetrating substrates.

## Changeables

- 8580 Washed Sand Finish (Oak Veneers, Ash Hardwoods; Particle Board Cores)  
8582 Light Cherry Finish (Cherry Veneers, Select Hardwoods; Particle Board Cores)  
8583 Dark Mahogany Finish (Cherry Veneers, Select Hardwoods; Particle Board Cores)  
8584 Natural Oak Finish (Oak Veneers, Ash Hardwoods; Particle Board Cores)

### General Casegoods Specifications

#### 1. Unique Specifications

- High Pressure Laminate
- Solids Species: Select Hardwoods

#### 2. Wood Species

- All exposed solids are kiln dried hardwoods, premium graded, selected to be free of visual and structural defects.
- All non-exposed solids are sound grade, kiln dried Northern grown hardwoods.

#### 3. Top Construction

- High Pressure Laminate Tops
- Contract Grade Particle Board Core with minimum density of 45 lbs.
- Gator-ply backer for balanced construction.
- Case tops have 3/4" lumber bands on front and side edges and a lacquer sealed matching finish on the back edge.
- Desk and Occasional Item Tops have 3/4" lumber bands on 4 edges.

#### 4. End Panel Construction

- Particle Board Core with Specified Veneer Face (as described above).
- Color matched edge band on back edge.
- PVC bottom edge band to prevent moisture absorption.

#### 5. Drawer Front Construction

- Particle Board Core with Specified Veneer Face (as described above) with Veneer Edgebanding.

#### 6. Drawer Box Construction

- Plywood Drawer Sides and Drawer Backs.
- English Dovetail construction with removable Drawer Fronts.
- Drawer Bottom is tempered hardboard with a printed wood grain finish and is glued on all four sides into drawer grooves.
- Drawer Interiors are smooth and sealed.
- Epoxy Coated 3/4 Extension Ball Bearing Side Guides in black finish with 75 lb. rating.

#### 7. Back Panels

- Non Exposed Back panels are constructed of Pressed Board, are recessed and are stapled to cleats.
- Exposed Back Panels compliment the finish of the suite to provide a finished appearance on the front side of the case.



## **8. Case Construction**

- All cases contain full length Top Front Rails, Top Back Rails, Bottom Panels (or Bottom Front and Back Rails) for maximum strength.
- All cases are secured with cleats, corner blocks, screws and glue.
- All cases with large doors have 4 adjustable floor glides, one in each corner of the case.
- Media Chests and Microfridge Cabinets have Anti-Sag Rails beneath tops to prevent sagging from the weight of televisions.

## **9. Desks, Tables and Occasional Items**

- Tops contain a 3/4" lumber band on all four edges.
- Legs are solid hardwoods.
- Legs are secured using corner blocks, glue, screws and 2 lag bolts for additional strength and stability.

## **10. Headboards**

- Headboards are wall mounted and sized to match the sleep set.
- Angled Wall Mounting Brackets are provided for installation.

## **11. Finish Standards**

- All cases proceed through an eight step finishing process producing an attractive finish with a Pre-Catalyzed Lacquer Top Coat for durability.

## **12. Warranty**

- Manufacturer warrants for the greater of (i) Manufacturer's standard warranty period, or (ii) Five (5) years from date of invoice, that all casegood products (the "Products") shall be new, free from defects in material. Workmanship and design shall conform to any and all applicable specifications, drawings, samples and descriptions referred to in this Preamble and shall be suitable for the purpose for which intended. Manufacturer warrants it has the right to convey or provide the Products and that same are free of all liens and encumbrances. These warranties shall survive any inspection, delivery, or payment for the Products, and termination of this Preamble, and the benefit thereof shall run to Buyer, its successors, assigns and customers. Manufacturer shall repair or replace all Products failing to comply with the warranty set forth herein with complying Products. Manufacturer shall bear all warranty costs such as labor, material, inspection and shipping to and from Buyer's facilities. If Buyer incurs any such costs, it may either recover them directly from Manufacturer or deduct them from any amounts due Manufacturer as agreed between the two parties.

## Bridges 2.0

48183 - Newbridge Finish  
48185 - African Walnut Finish

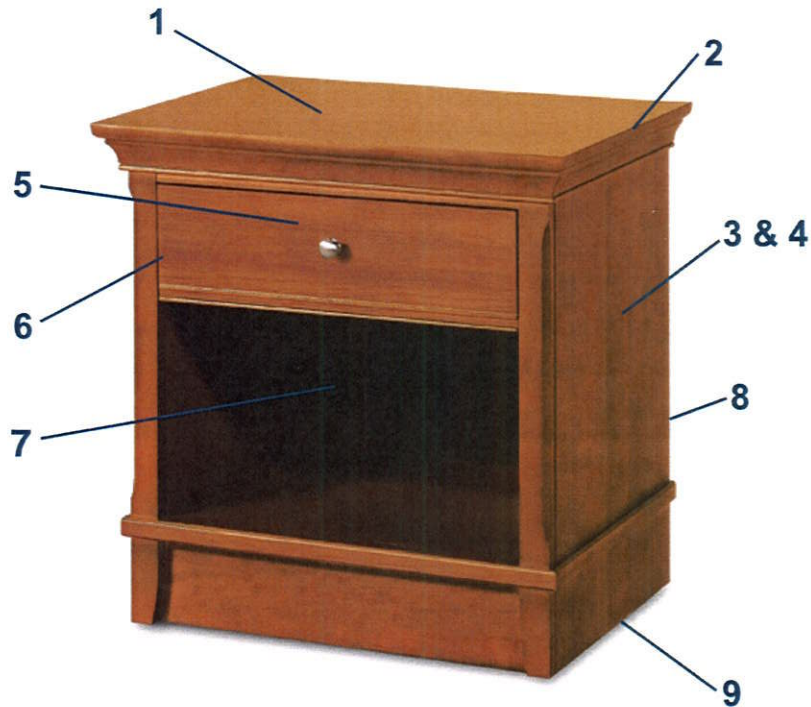

48183-806 Night Stand  
24-1/8" W x 17-3/4" D x 24" H

### Features

- 1) High Pressure Laminate Top.
- 2) Lumber Banded Top Edge Treatment with Nitrocellulose Lacquer Top Coat.
- 3) Cherry Veneers and Select Hardwood Solids.
- 4) 18 Step Finish with a UV Cured Catalyzed Polyurethane Top Coat.
- 5) UV Cured Finish on 7/16" Thick Baltic Birch Plywood Drawer Box with Front and Back English Dovetails and a 3/16" Veneered Plywood Drawer Bottom.
- 6) 75 lbs. Rated Ball Bearing Side Guides.
- 7) 1/8" Exposed Printed Hardboard Back Panel.
- 8) Recessed Back Panel.
- 9) PVC Edge Banding on all bottom edges.

### Benefits

- 1) Prevents scratches and resists moisture.
- 2) Highly durable and resists water.
- 3) Cherry veneers add warmth and beauty to the finish and meets brand specifications requiring veneered product.
- 4) Our 16 step finish process adds the depth and clarity found in high end residential finishes.
- 5) Our dovetail construction creates superb strength and a highly durable drawer.
- 6) Well fitted, longer lasting drawers with minimal side to side movement.
- 7) Exposed back panel finish matches the case finish.
- 8) Allows case to be placed flush against walls without interfering with electrical cords.
- 9) Helps prevent moisture from penetrating substrates.

## Bridges 2.0

48183 – Newbridge Finish

48185 – African Walnut Finish

### General Casegoods Specifications

#### A. GENERAL CONSTRUCTION

- ❑ Joints are mortised and tenoned, doweled or blocked glued and pinned, following the best practice of commercial construction.
- ❑ All case table and chair joints are glued with an approved PVA assembly adhesive that conforms to the ASTM D-905-89 test requirement of average block shear strength of not less than 2800 lbs. per square inch.
- ❑ All corner blocks, braces and screw cleats are glued and reinforced with staples, nails or screws.
- ❑ All corner blocks and braces are made of solid wood.
- ❑ All structural members are glued and screwed or stapled in place.
- ❑ All excess glue is cleaned from surfaces exposed during normal use
- ❑ Contract design case tops are surfaced with custom matched high-pressure laminate .030” thick that conforms to Federal Specification LP508H. Laminate adhesives are either urea resins or PVA’s. Top cores are 45 lb. density industrial grade particle board in accordance with specification ANSI A208.1-1993. Tops are edge banded with a 1 ½” wide piece of ¾” hardwood lumber.
- ❑ All end panels are a three-ply veneer construction with a 45 lb. density particleboard core. Exposed end panel edges are lumber banded on the front edge.
- ❑ Back panels on contract design cases are recessed allowing cases to fit snugly against walls over electrical plugs and cords, maximizing the space in the room.
- ❑ Casters and base blocks are glued and screwed allowing for free movement of the caster.
- ❑ All cases over 60” have a center foot.

#### B. MATERIAL REQUIREMENTS

- ❑ All wood is dried to a moisture content of 6-7½ % and conditioned to produce a stress free board. This process keeps distortion and warping to a minimum and ensures firm bonding joints in widely varying climate conditions. Moisture is checked using ASTM D-\*143.
- ❑ Exposed solid parts are premium grade hardwood free of knots, decay, season cracks, mineral streaks, bark, warp, twist or any other defect that adversely affects strength or appearance. Loose knots and wormholes are not permitted.
- ❑ Unexposed solid parts are select hardwoods free from knots, decay, warp, twist or any other defect that adversely affects strength.
- ❑ Exposed sliced cherry face veneers are selected based on good texture and uniform color. Veneers are book or slip matched on case fronts.
- ❑ All veneered panels are constructed with waterproof glue under controlled pressure. Panels are manufactured with balanced multidirectional plied construction.
- ❑ Glues and Adhesives are routine tested by Thomasville’s Quality Control Lab for a variety of factors including viscosity, PH, reactivity and solids content to insure they are formulated correctly and provide the required holding strength.
- ❑ Back panels are 1/8” hardboard fastened securely by gun staples. Fasteners are flush with the outside back and do not swell, split or protrude through finished surfaces. Back panels are not a structural component of the case

- Drawer fronts are hardwood with cherry veneer. Drawer sides and backs are constructed of Baltic Birch plywood joined front and rear with English style dovetails. English dovetails provide more secure interlocking than other dovetail methods. In addition English dovetails provide the maximum glue surface, compared to other construction methods such as French dovetails. Drawer bottoms, constructed of 3.6-mm plywood, are secured in grooves front side and back using hot melt adhesive for maximum rigidity and durability. Drawer interiors are sanded and finished with a coat of sealer and an UV polyester topcoat insuring a smooth interior drawer surface.
- Drawer guides are 75 lb. Epoxy Coated Ball Bearing heavy duty side guides.
- Particleboard Standards
  - All particle board meets ANSI A208.1-1993
  - Tops with particleboard cores are lumber banded on three or four sides with edge banding on the back edges if they are not lumber banded.
  - Cases have no exposed particleboard.
  - Particle board used in doors is banded on all four sides.
- Hardware has a rust and tarnish proof finish.
- Packaging materials are custom designed for each item to minimize shipping damage. The Thomasville Testing Lab conducts various packaging materials tests based on the National Safe Transit Association "Pre-Shipment Test Procedures". These tests include impact simulation, vertical drop testing and over the road vibration simulation. These tests measure the effectiveness of the carton as well as the structural integrity of the case itself. Changes are made in packaging or case constructions if weaknesses are found.

### C. WORKMANSHIP

- Doors are properly aligned to insure uniform clearance and operation free of rattle, squeak or rubbing. Catches are properly aligned and installed with a minimum requirement of two catches on all but small dresser doors.
- Drawers are custom fitted to insure free running action with no binding, sticking, rattling or squeaking. Drawer guides and runners are securely fastened and properly positioned to assure correct drawer alignment.
- Cross grain sanding, machine marks, splits, chip outs, veneer checking, or roughness are not permitted on the surface of the finished product.
- Drawer interiors and other interior storage compartments are sanded smooth and are free of glue or lacquer runs. Sides, ends and bottoms are free of splinters, snags, splinters, staples, nails and screws.
- All hardware including hinges, pulls, latches, catches and glides are attached and fitted to operate properly and serve their purpose during transit and use.
- Miter joints are square, flush, tight and well glued. Exposed case front joints are tight not exceeding 1/64".
- Case tops are attached to the case with screws allowing the top to be pulled down tight against the case.
- Interior screws are flush or countersunk to the surface of the part where used.
- Assembly and hinge screws are properly seated and driven flush with the hinge flange.
- All glides and casters are properly attached.
- All molding and overlays are nailed from the back of the panel if possible. Face nails or brads are driven flush or set and nail holes filled.

## **D. APPEARANCE AND FINISH**

- Finishing is accomplished with the following eighteen step process.
  1. Pre-stain is applied to tie in hardwood solids to match cherry veneers.
  2. A uniformed wet coat of pre-stain is applied overall.
  3. A uniformed wet coat of body stain is applied overall.
  4. Pre-seal is applied to solid wood parts and end grain that may go dark at glaze.
  5. A uniformed wet coat of sealer is applied over all.
  6. Once thoroughly dried the coat of sealer is sanded.
  7. Dark areas are highlighted with scotchbrite. Low areas and corners are brushed out.
  8. A uniforming stain is used to carefully blend overall color, tying in wood solids to cherry veneers.
  9. A second coat of sealer is applied over all.
  10. Once thoroughly dried the second coat of sealer is sanded.
  11. Pad stain is hand padded onto the case. The material is customized as needed to match the color standard.
  12. A uniformed wet coat of 20 sheen lacquer is applied overall.
  13. Glaze is dry brushed to match the color standard and raw edges are touched-up.
  14. A second coat of 20 sheen lacquer is applied.
  15. A third coat of 20 sheen lacquer is applied.
  16. Interior stain is applied prior to final assembly.
  17. All uprights and parting rails are padded with stain.
  18. Drawer dovetails are stained prior to drawer assemble for checker-board effect.
- Uniformity of color is achieved between different manufacturing locations and from one production run to the next. Each item is compared to an approved color case to insure a consistent finish match.
- Color comparisons are made in the Thomasville testing lab to verify the color match of each batch of finishing material.
- Interior surfaces of compartments and drawers are free of dirt, dust, shavings and other foreign matter before finishing.
- Edges and backs of doors and drawers edges are finished to be compatible with the case exterior.
- The finish has passed durability testing conducted by the Thomasville Testing Lab based on the guidelines of ASTM Test D 1308-87, which is the “Standard Test Method for Effect of Household Chemicals on Clear, and Pigmented Organic Finishes”. This test demonstrates that the finish is colorfast and resists staining from extended exposure to common household products.

## **E. PERFORMANCE**

- Drawers and doors are fitted and aligned to operate smoothly under various atmospheric conditions.
- All drawers, doors and other operating parts are properly fitted and aligned to operate smoothly without loose or sloppy action
- Doors and door hinges operate smoothly and quietly without binding, rubbing or rattling.
- Drawers have passed the ANSI/BIFMA X5.5-1998 Section 7 test. This test requires drawers loaded with 51.5 lbs. of weigh to open and closed for 50,000 cycles with no structural breakage or lose of serviceability.
- Doors have passed the ANSI/BIFMA A156.9-1994 Section 4.3 test. This test requires doors to open and close 100,000 cycles with no structural breakage or lose of serviceability.
- Numerous precautions are taken throughout the production process, from design to lumber drying to panel construction, to insure warping does not occur once a case is completed.

- Hardware, both trim and functional, is straight and firmly attached.

## **F. FEATURES OF INDIVIDUAL ITEMS**

### **1. Chairs**

- All chair designs have passed a cycle test that simulates a 200 lb. person rocking back and forth in the chair 15,000 times, with zero failures. This rocking is the motion that exerts the most strain on the dowel joints between the front posts, side rails, and the back post of the chair giving a relative indication of the chair's structural integrity.
- Chair side rails contain three 3/8" grooved birch dowels in a 20 1/4" wide rail. The interior sides of the chair rails contain multi-grooves with four corner blocks matched to the grooves. Corner blocks are PNA glued and screwed into place. One corner block is screwed into the back post.
- Chair joints are properly angled and clamped tight. No openings are permitted in the joints.
- Leg stretchers, which enhance the structural strength of the chair by providing increased stability to the legs, are machined (chucked) for a tight fit and glued into place.
- Seat and back cushions are tailored and fit properly to the frame.

### **2. Headboards**

- Panel headboards are available in both wall-hung (sizes 3/3, 4/6, 5/0 & 6/6) designs. Mounting instructions are included for wall hung models.
- Custom fitted leg kits are available to convert wall-hung headboards to free standing.

### **3. Night Stands**

- Both one drawer and two drawer night stands are available in a variety of sizes and designs.

### **4. Mirrors**

- Mirror glass is 3/16" plate glass with copper electroplate backs to protect the silver surface.

### **5. Desk & Writing Tables**

- Writing tables include a center stationery drawer
- Custom writing tables in varying sizes, with and without a drawer, can be designed to meet the requirement of specific projects.
- Writing tables are shipped KD (without the legs attached) minimizing freight damage and reducing freight costs.

### **6. Occasional Tables**

- The occasional table collection includes cocktail tables, end tables and activity tables.
- Contract design occasional tables are shipped KD (without the legs attached) minimizing freight damage and reducing freight costs.

# Color Cafe

## **Warranty: One Year** General Casegoods Specifications

### **A. GENERAL CONSTRUCTION**

- Joints are mortised and tenoned, doweled or blocked glued and pinned, following the best practice of commercial construction.
- All case table and chair joints are glued with an approved PVA assembly adhesive that conforms to the ASTM D-905-89 test requirement of average block shear strength of not less than 2800 lbs. per square inch.
- All corner blocks, braces and screw cleats are glued and reinforced with staples, nails or screws.
- All corner blocks and braces are made of solid wood.
- All structural members are glued and screwed or stapled in place.
- All excess glue is cleaned from surfaces exposed during normal use
- All tops are birch solids.
- All end panels birch solids.

### **B. MATERIAL REQUIREMENTS**

- All wood is dried to a moisture content of 6-7½ % and conditioned to produce a stress free board. This process keeps distortion and warping to a minimum and ensures firm bonding joints in widely varying climate conditions. Moisture is checked using ASTM D-\*143.
- Exposed solid parts are premium grade hardwoods free of knots, decay, season cracks, mineral streaks, bark, warp, twist or any other defect that adversely affects strength or appearance. Loose knots and wormholes are not permitted.
- Unexposed solid parts are select hardwoods free from knots, decay, warp, twist or any other defect that adversely affects strength.
- Glues and adhesives are routine tested by Thomasville's Quality Control Lab for a variety of factors including viscosity, PH, reactivity and solids content to insure they are formulated correctly and provide the required holding strength.
- Back panels are 3/16" plywood fastened securely by gun staples. Fasteners are flush with the outside back and do not swell, split or protrude through finished surfaces. Back panels are not a structural component of the case.
- Drawer fronts are birch solids.
- Drawer sides and backs are constructed of Baltic Birch plywood joined front and rear with English style dovetails. English dovetails provide more secure interlocking than other dovetail methods. In addition English dovetails provide the maximum glue surface, compared to other construction methods such as French dovetails.
- Drawer bottoms, constructed of 3.6 mm plywood, are secured in groves front side and back using hotmelt adhesive for maximum rigidity and durability. Drawer interiors are sanded and finished with a coat of sealer and an UV polyester topcoat insuring a smooth interior drawer surface.
- Drawer guide system is a wooden dovetailed runner and guide system made of hard maple utilizing a metal reinforcement bracket at the back of the drawer and also wooden anti-tilt rails above the drawers.
- Particleboard Standards
  - All particle board meets ANSI A208.1-1993
  - Cases have no exposed particleboard.
- Hardware has a rust and tarnish proof finish.
- Packaging materials are custom designed for each item to minimize shipping damage. The Thomasville Testing Lab conducts various packaging materials tests based on the National Safe Transit Association "Pre-Shipment Test Procedures". These tests include impact

simulation, vertical drop testing and over the road vibration simulation. These tests measure the effectiveness of the carton as well as the structural integrity of the case itself. Changes are made in packaging or case constructions if weaknesses are found.

### C. WORKMANSHIP

- Doors are properly aligned to insure uniform clearance and operation free of rattle, squeak or rubbing. Catches are properly aligned and installed with a minimum requirement of two catches on all but small dresser doors.
- Drawers are custom fitted to insure free running action with no binding, sticking, rattling or squeaking. Drawer guides and runners are securely fastened and properly positioned to assure correct drawer alignment.
- Cross grain sanding, machine marks, splits, chip outs, veneer checking, or roughness are not permitted on the surface of the finished product.
- Drawer interiors and other interior storage compartments are sanded smooth and are free of glue or lacquer runs. Sides, ends and bottoms are free of splinters, snags, splinters, staples, nails and screws.
- All hardware including hinges, pulls, latches, catches and glides are attached and fitted to operate properly and serve their purpose during transit and use.
- Miter joints are square, flush, tight and well glued. Exposed case front joints are tight not exceeding 1/64".
- Case tops are attached to the case with screws allowing the top to be pulled down tight against the case.
- Interior screws are flush or countersunk to the surface of the part where used.
- Assembly and hinge screws are properly seated and driven flush with the hinge flange.
- All glides and casters are properly attached.
- All molding and overlays are nailed from the back of the panel if possible. Face nails or brads are driven flush or set and nail holes filled.

### D. APPEARANCE AND FINISH

- Finishing is accomplished with the following eighteen step process.
  1. Pre-stain is applied to tie in hardwood solids to match cherry veneers.
  2. A uniformed wet coat of pre-stain is applied overall.
  3. A uniformed wet coat of body stain is applied overall.
  4. Pre-seal is applied to solid wood parts and end grain that may go dark at glaze.
  5. A uniformed wet coat of sealer is applied over all.
  6. Once thoroughly dried the coat of sealer is sanded.
  7. Dark areas are highlighted with scotchbrite. Low areas and corners are brushed out.
  8. A uniforming stain is used to carefully blend overall color, tying in wood solids to cherry veneers.
  9. A second coat of sealer is applied over all.
  10. Once thoroughly dried the second coat of sealer is sanded.
  11. Pad stain is hand padded onto the case. The material is customized as needed to match the color standard.
  12. A uniformed wet coat of 20 sheen lacquer is applied overall.
  13. Glaze is dry brushed to match the color standard and raw edges are touched-up.
  14. A second coat of 20 sheen lacquer is applied.
  15. A third coat of 20 sheen lacquer is applied.
  16. Interior stain is applied prior to final assembly.
  17. All uprights and parting rails are padded with stain.
  18. Drawer dovetails are stained prior to drawer assemble for checker-board effect.
- Uniformity of color is achieved between different manufacturing locations and from one production run to the next. Each item is compared to an approved color case to insure a consistent finish match.



- Color comparisons are made in the Thomasville testing lab to verify the color match of each batch of finishing material.
- Interior surfaces of compartments and drawers are free of dirt, dust, shavings and other foreign matter before finishing.
- Edges and backs of doors and drawers edges are finished to be compatible with the case exterior.
- The finish has passed durability testing conducted by the Thomasville Testing Lab based on the guidelines of ASTM Test D 1308-87, which is the “Standard Test Method for Effect of Household Chemicals on Clear, and Pigmented Organic Finishes”. This test demonstrates that the finish is colorfast and resists staining from extended exposure to common household products.

#### **E. PERFORMANCE**

- Drawers and doors are fitted and aligned to operate smoothly under various atmospheric conditions.
- All drawers, doors and other operating parts are properly fitted and aligned to operate smoothly without loose or sloppy action
- Doors and door hinges operate smoothly and quietly without binding, rubbing or rattling.
- Numerous precautions are taken throughout the production process, from design to lumber drying to panel construction, to insure warping does not occur once a case is completed.
- Hardware, both trim and functional, is straight and firmly attached.

#### **F. Features of Individual Items**

##### **1. Chairs**

- Chair side rails contain dowels. The interior sides of the chair rails contain multi-grooves with four corner blocks matched to the grooves. Corner blocks are PNA glued and screwed into place. One corner block is screwed into the back post.
- Chair joints are properly angled and clamped tight. No openings are permitted in the joints.
- Leg stretchers, which enhance the structural strength of the chair by providing increased stability to the legs, are machined (chucked) for a tight fit and glued into place.
- Seat and back cushions are tailored and fit properly to the frame.

# Thomasville<sup>®</sup>

## CONTRACT

### WARRANTY

#### Color Café

1 year

#### Thomasville Bridges Collection

*Thomasville Contract is a renowned resource for quality crafted furniture.*

Since 1904, creating fine furniture with craftsmanship you can see and quality you can depend on has been a Thomasville tradition, handed down from generation to generation. Our dedication to quality and attention to detail assures you are purchasing the most durable contract furnishings available.

Bridges 2.0 brings together elements of traditional Shaker and contemporary style to create a design that celebrates both the past and the present. ♦

#### *Bridges 2.0 Features and Benefits*

- ♦ Bridges 2.0 is composed of hardwood solids and cherry veneers. You have your choice of two finishes.
- ♦ Drawer sides and backs are constructed of Baltic birch plywood, joined front and rear with English style dovetails.
- ♦ Tops are surfaced with custom matched high-pressure laminate and are lumberbanded.
- ♦ The extension drawer guides are epoxy-coated, ball-bearing, and side-mounted.
- ♦ The hardware is nickel finished.
- ♦ Back panels are recessed to allow space for electrical receptacles while the furniture remains flush to the wall.
- ♦ Five year limited warranty

5 years



*We are confident in the durability and craftsmanship of our products – so confident that all Thomasville Contract furnishings are backed by an exclusive 5 year warranty.*

## *Changeables Select*

*Thomasville Contract is a renowned resource for quality crafted furniture*

Thomasville Contract is eager to meet your specific furnishing requirements whether it is a convention hotel, restaurant, office, government installation, or assisted living facility. We offer an extensive line of price and style options to suit your needs.

In the vast Thomasville Contract line you will discover 18th Century designs, transitional furnishings, sleek functional contemporary pieces, and much, much more.

Our dedication to quality and attention to detail assure that you are purchasing the most durable contract furnishings available. Carefully crafted and built to withstand the demands of everyday contract use, all Thomasville Contract pieces include scratch and stain resistant finishes, reinforced case construction for longer life, smooth operating drawer guides, and many other high quality features.

Since 1904, creating fine furniture with craftsmanship you can see and quality you can depend on has been a Thomasville tradition, handed down from generation to generation.

Thomasville Contract... a name your clients will recognize with appreciation. . a product line you can specify with confidence. ♦



*We are confident in the durability and craftsmanship of our products – so confident that all Thomasville Contract furnishings are backed by an exclusive 5 year warranty.*

**Thomasville**  
CONTRACT



*Changeables-Select -Particle Board Core Version*

- 8580 Washed Sand Finish (Oak Veneers, Ash Hardwoods)
- 8582 Light Cherry Finish (Cherry Veneers, Select Hardwoods)
- 8583 Dark Mahogany Finish (Cherry Veneers, Select Hardwoods)
- 8584 Natural Oak Finish (Oak Veneers, Ash Hardwoods)

**Molding Options**

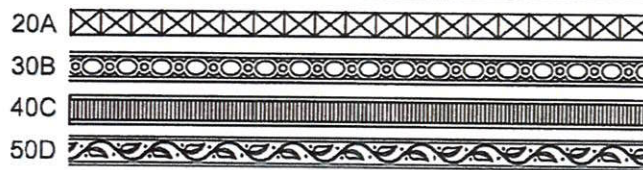

**Hardware Options**

- W42 (Dark Antique Brass Finish)  
- W52 (Black Iron Finish)  
- W62 (Antique Copper Finish ) 
- W72 (Black Iron Finish) 

**Base Options**

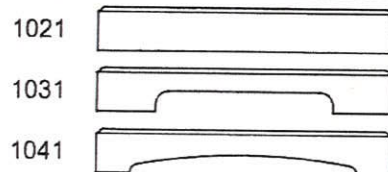



## BEST VALUE CONSIDERATIONS

1. Thomasville has been manufacturing furniture since 1904- more than 100 years. The company is recognized as being one of the leading manufacturers of quality Furniture, backed with extended warranties.
2. Thomasville is owned by Furniture Brands International, the largest furniture Resource in the world. Furniture Brands owns not only Thomasville, but also Broyhill, Lane, Drexel, Henredon, Hickory Chair and Hickory Business furniture, etc. Furniture Brands has the financial wherewithal and resources to handle significantly large projects.
3. Our past experience in the military housing area, as supported by the large list on Installations we have just for 2010, attests to our ability to manage turnkey projects and to meet the expectations and delivery dates of the customer.
4. Our marketing representatives are specialized in the area of military housing and as employees of the company (not independent representatives) represent only Thomasville Furniture, so we completely understand our products. We subcontract and team with other companies to provide the military housing customer with a one-source solution.

The Marketing Representative who would be responsible for managing this Installation, Paige Via, has represented Thomasville for the residential, commercial and government markets for over 32 years. Paige thoroughly understands the nuances associated with turnkey projects, particularly those offshore. Paige has been involved in many installations in the Far East, West Coast and her current territory which consists of seven Eastern/mid-Western States, GTMO, Puerto Rico and parts of Latin America.

5. Since Thomasville sells directly to the government and not through third party dealers, we have the ability to control the production, shipping, and resolve any warranty or Quality issues which may arise in the field.
6. Our Materials Testing Laboratory located in Thomasville is truly unique among furnishings manufacturers. This facility operates on a daily basis to insure that the Quality of materials shipped to Thomasville meet our specifications as well as the GSA and ANSI/BIFMA standards. Daily production runs of product are randomly selected from the warehouse to be tested for strength, durability, etc.
7. Since 1984 Thomasville has been one of the leading, if not the leading, supplier for GSA's Household and Quarters and Packaged Room Projects. This would attest to our effectiveness in this area as well as our competitiveness.

## Test Description

Test	Description
ASTM L 1037 Sec 100 - 107 Water Absorption & Thickness Swelling	Effects of water
ASTM D 1037 Sec 120 - 121 M.C. & Specific Gravity	Oven M.C. test
ASTM D 5582 Determination of Formaldehyde Levels Using a Desiccator	Formaldehyde Emissions
<b>Hardboard</b>	
ASTM D 1037 Sec 152 - 155 Thickness	Bending Strength
ASTM D 1037 Sec 156 - 159 Modulus of Rupture	Internal Bond strength
ASTM D 1037 Sec 162 - 163 Tensile Strength Perp. To Surface	Effects of water
ASTM D 1037 Sec 164 - 165 Water Absorption & Thickness Swelling	Oven M.C. test
ASTM D 1037 Sec 166 - 167 Moisture Content & Specific Gravity	
<b>Adhesives</b>	
ASTM D 905 - 98 Adhesive Bonds in Shear by Compression Loading	Shear tests
ASTM D 906 - 98 Adhesives in Plywood in Shear by Tension	Plywood shear tests
ASTM D 1084 - 97 Standard Test Method for Viscosity of Adhesives	Viscosity
ASTM D 1490 - 01 Nonvolatile Content of Urea-Formaldehyde Resin	% Solids
ASTM D 899 - 00 Applied Weight Per Unit Area of Liquid Adhesives	Glue Spread
ASTM D 2339 - 98 Strength of Adhesives in Two-Ply Wood Construction in Shear by Tension Loading	2-Ply Shear Test
ASTM D 4317 - 98 Polyvinyl Acetate-Based Emulsion Adhesives	Type Bond Tests (boiling H2O)
ASTM D 4690 - 99 Urea Formaldehyde Resin Adhesives	Physical & Bonding Tests
ASTM D 5572 - 95 Adhesives Used for Finger Joints in Nonstructural Lumber Products	Finger Joint Tests
<b>Finish</b>	
ASTM D 1211 - 97 Temperature-Change Resistance of Clear NC Lacquer Films Applied to Wood	Cold Check Test
ASTM D 3359 Adhesion by Tape Test	Cross Hatch
ASTM D 2197-98 Adhesion of Organic Coatings by Scrape Adhesion	Scratch adhesion test
ASTM D 2091 Print Resistance of Lacquers	Lacquer printing under load
ASTM D 1005 - 95 Measurement of Dry-Film Thickness of Organic Coatings Using Micrometers	Film Thickness
ASTM D 1308 Effect of Household Chemicals on Clear and Pigmented Organic Finishes	Garbage Test
ASTM D 2199 Measurement of Plasticizer Migration from Vinyl Fabrics to Lacquers	Plasticizer Migration
ASTM D 2571 Guide for Testing Furniture Lacquers	
ASTM D 2134 - 93 Hardness of Organic Coatings with a Sward-Type Hardness Rocker	Sword Hardness Test
ASTM D 523 - 89 Specular Gloss Test Method	
UV Light Tests	Sheen Color Fastness to Light

# Thomasville® Testing Laboratory

Testing Furniture Products  
Since 1964



The Thomasville Laboratory has a long history of testing furniture and component materials. The Lab routinely conducts package tests, new product performance evaluations, and investigations of quality issues both inside the company and from our customer service department. Although the laboratory follows published test standards, we are not a certified test facility. For example, some tests such as ASTM F-1427 for the evaluation of bunk beds must be performed by a certified third party test lab. However, our lab is capable of pretesting to the F 1427 standard to determine if the bed is in compliance before money is spent for outside testing services. Inside is a list of tests the Thomasville Laboratory is capable of performing.

**Gen. Manager of Technical Services:**  
David Burkhardt  
(336) 476-2185  
d Burkhardt@thomasville.com

**Contact Information**  
**Packaging Engineer:**  
Alec Cathey  
(336) 476-2114  
acathey@thomasville.com

**Laboratory Manager:**  
Lee Elrod  
(336) 474-4871  
lelrod@thomasville.com

Test	Description
<b>Beds</b>	
ASTM F 1427-07 Safety Specification for Bunk Beds (3rd Party Certification Required)	Bunk bed requirements
<b>Blanket &amp; Toy Chests</b>	
ASTM F 834-84 Safety Specification for Toy Chests	Toy Chest requirements
<b>Cases</b>	
ANSI/BIFMA X5.5-1998 Sec. 10 Racking Test	45 degree rack test
ANSI/BIFMA X5.5-1998 Sec. 11 Drop Test	Drop 1 end 10"
ANSI/BIFMA X5.5-1998 Sec. 23 Force Stability for Tall Desk Products	Push over stability test
ANSI/BIFMA X5.5-1998 Sec. 24 Dislodgement Tests for Tall Desk Products	50 lb pendulum impact
ASTM F 2057-00 Safety Specification for Chests, Door Chests, and Dressers	Tip over test
UL-962 (3rd Party Certification Required)	Electrical, Stability, Strength
<b>Chairs</b>	
ANSI/BIFMA X5.1-1993 Sec. 5 Back Strength Type I	Chair back pull
ANSI/BIFMA X5.1-1993 Sec. 6 Back Strength Type IIa	Chair back pull
ANSI/BIFMA X5.1-1993 Sec. 7 Back Strength Type IIb	Chair back pull
ANSI/BIFMA X5.1-1993 Sec. 9 Drop Test - Dynamic	Load dropped in seat
ANSI/BIFMA X5.1-1993 Sec. 11 Tilt Mechanism Test - Cyclic	Tilt mechanism durability
ANSI/BIFMA X5.1-1993 Sec. 12 Seating Impact Test - Cyclic	Cyclic load dropped in seat
ANSI/BIFMA X5.1-1993 Sec. 13 Stability Test - Dynamic	Tip over test
ANSI/BIFMA X5.1-1993 Sec. 14 Arm Strength - Vertical - Static	Vertical load on top of arm
ANSI/BIFMA X5.1-1993 Sec. 15 Arm Strength - Horizontal - Static	Horizontal arm pull
ANSI/BIFMA X5.1-1993 Sec. 16 Back Durability - Cyclic - Type I	Tilt seat chair, back durability
ANSI/BIFMA X5.1-1993 Sec. 16 Back Durability - Cyclic - Type IIa & IIb	Chair back durability
ANSI/BIFMA X5.1-1993 Sec. 19 Leg Strength - Front Application - Static	Leg pull
ANSI/BIFMA X5.1-1993 Sec. 20 Leg Strength - Side Application - Static	Leg pull
ANSI/BIFMA X5.1-1993 Sec. 21 Footrest Durability - Vertical - Cyclic	Cyclic load on foot rest
Thomasville Chair Rocking Test	Rocking chair with a load
<b>Doors</b>	
ANSI/BIFMA X5.5-1998 Sec. 17 Hinged Door Test	Door hinge strength test
ANSI/BIFMA X5.5-1998 Sec. 18 Cycling Test for Receding Doors	Pocket door mechanism durability test
ANSI/BIFMA X5.5-1998 Sec. 19 Sliding & Roll Front Door Tests	Sliding door mechanism durability test
ANSI/BIFMA X5.5-1998 Sec. 20 Door Latch Test	Door latch durability test

Test	Description
<b>Drawers</b>	
ANSI/BIFMA X5.5-1998 Sec. 7 Extendible Member Cycle Test	Drawer Cycle Test
ANSI/BIFMA X5.5-1998 Sec. 8 Out Stop Test	Drawer pullout stop test
ANSI/BIFMA X5.5-1998 Sec. 9 Rebound Test	Drawer slam rebound test
ANSI/BIFMA X5.5-1998 Sec. 16 Interlock Test	Interlock mechanism test
ANSI/BIFMA X5.5-1998 Sec. 25 Pull Force Test Package and General Tests	Measure force to open dwr
Thomasville EMC Test (Climate Simulation)	Temp. & R.H. Chambers
Modified ISTA 1A, 1B	Package Testing
Thomasville Developed Package Test	Package Testing
<b>Hardware</b>	
ANSI/BIFMA X5.1-1993 Sec. 18 Caster/Chair Base Durability Test - Cyclic	Caster durability over 1/8" strips
ANSI/BIFMA X5.5-1998 Sec. 14 Caster Durability Test - Mobile Pedestals	Caster durability over 1/8" strips
ANSI/BIFMA X5.5-1998 Sec. 21 Durability Test for Desks/Tables w/ Casters	Caster durability over flat surface
ANSI/BHMA A156.9-2003 Sec. 4.7 Knob and Pull Load Test	Load on hardware pulls
ANSI/BIFMA X5.5-1998 Sec. 6 Lock Test	Lock durability tests
<b>Tables</b>	
ANSI/BIFMA X5.5-1998 Sec. 4 Unit Static Loading	Static load on tops & shelves
ANSI/BIFMA X5.5-1998 Sec. 5 Top Load Ease Test - Cyclic	Cycling load on tops
ANSI/BIFMA X5.5-1998 Sec. 12 Leg Strength Test	Horizontal leg pulls
ANSI/BIFMA X5.5-1998 Sec. 13 Stability Test	Tip over tests
GSA-AA-H-001895D Extension Table Test (Table Sag Test)	Table sag measured under load
<b>Upholstery</b>	
Cal 117, Section D	Foam cigarette test
UFAC (3rd Party Certification Required)	Foam cigarette test
NFPA 260 Flammability	Foam cigarette test
NFPA 261 Flammability	Foam cigarette test
<b>Parts Testing</b>	
<b>Solid Wood</b>	
ASTM D 143 Sec. 8 Static Bending	Modulus of Rupture
ASTM D 143 Sec. 13 Hardness	Ball Hardness
ASTM D 143 Sec. 18 Nail Withdrawal	Nail holding strength
ASTM D 143 Sec. 21 Moisture Content Tests	Oven M.C. test
<b>Particleboard &amp; MDF</b>	
ASTM D 1037 Sec. 11 - 20.1 Static Bending	Modulus of Rupture
ASTM D 1037 Sec. 21 - 33 Tensile Strength Perpendicular. To Surface	Internal Bond strength
ASTM D 1037 Sec. 47 - 53 Nail Withdrawal Test	Nail holding strength
ASTM D 1037 Sec. 61 - 67 Screw Withdrawal Test	Screw holding strength
ASTM D 1037 Sec. 68 - 73 Hardness Test	Ball Hardness

## About Thomasville

Thomasville Furniture Industries entered the first decade of the 20th century as the fledgling Thomasville Chair Company in a bustling railroad-side community in the triad area of North Carolina, near High Point, the furniture capital. Founded in 1904, it was just one of many chair manufacturers scattered throughout North Carolina. It turned out 180 chairs a day and owed two local timber farmers, T.J. Finch and his brother C.F. Finch, \$2,000 for lumber.

When the company couldn't pay its debt in cash, the Finch brothers reluctantly accepted stock instead and decided to buy out the other stockholders. Business improved immediately under the astute guidance of the Finch family with sales topping \$1 million by 1917 and the company becoming recognized for innovations in design as well as manufacturing quality. The Thomasville Chair Company achieved many "firsts" for the furniture industry. These included the first national sales force in the furniture industry and the first American furniture company to produce and sell an entire suite of furniture: Thomasville dining tables, buffets and chairs.

To survive the Great Depression, the company stopped paying dividends to stockholders and management took a cut in salary. Then, in 1933 the company began a series of trade classes which enabled hundreds of their employees to learn new and better manufacturing techniques.

In 1941, Thomasville Chair Co. went to war with the rest of the country, making items requested by the federal government, including: double decker bunk beds for the Army, wooden plugs for bombs, tent stakes, wooden spatulas and rolling pins. And with 597 company men serving in the war, the first group of women reported for work in March of 1942.

During the 1950's, sales reached \$17 million, many innovations in machinery were made and the company's reputation for crafting quality furniture grew. In the '60s, the company (under the direction of Tom A. Finch) received a new name, Thomasville Furniture Industries, Inc. In 1968, it was acquired by Armstrong World Industries. In the 70's, Thomasville entered the contract market, providing furnishings for hotels and inns, primarily in the United States. In 1984, they expanded into Government sales, and their products can be found in military facilities worldwide. In December 1995, Thomasville was purchased by Furniture Brands International, Inc., a major residential furniture company located in St. Louis, MO.

Today, Thomasville Furniture Industries is a full-line furniture manufacturer with dedicated galleries in more than 400 leading independent retail furniture stores. Additionally, there are over 160 Thomasville Home Furnishing stores which carry only Thomasville products.

The corporate offices and showrooms are still located along the railroad tracks in Thomasville, NC. Today, employees number over 3,300 in manufacturing facilities in North Carolina and Virginia.

The famous Big Chair, an 18-foot reproduction of a Duncan Phyfe design (first erected in 1922 and rebuilt in 1951) still stands in the town square as a symbol of the mutual success of a now famous chair company - and the town that cherishes its nickname, "Chair City".

Thomasville Contract proudly manufactures the majority of its products in the USA with pride and integrity.



Paige Via, Government Sales Specialist  
105 Holman Road  
Williamsburg, VA 23185-5552  
Telephone: 757.565.2145  
Cell: 757.784.3015  
Fax: 757.565.96  
e-mail: mpaigevia@gmail.com

1. GSA Household & Quarters, which includes Package Rom GS-27F-0013J....Exp. 31 March 2014
2. Comprehensive Furniture Management Services Contract-GS-29F-0014U....Exp 5 May 2013
3. Navy BPA for SIN 71 200 Dormitory & Quarters, Packaged Room and SIN 71 204 Dormitory, Quarters and Residential Case goods & Beds....N00189-11-A-0010
4. Air Force Dormitory BPA FA4452-11-A-0004
5. Air Force NAF Contract F41999-09-D-0035
6. Drexel Heritage Furniture: GS-27F-3028D State Department Only
7. Please note that Thomasville's Cadence Furniture Collection & our upholstery are approved by Huntsville for Navy BEQ's & Army Barracks.
8. Thomasville Information:
  - a. Thomasville Furniture Industries, Inc.....FED TAX ID NO: 56-0903-574
  - b. CAGE Code: 59852
  - c. DUNS No: 00-3219-615
  - d. CCR Database Registration –ORCA Documents upon request
  - e. Ordering Address:

Thomasville Furniture Ind. Inc.  
P.O. Box 339  
Thomasville, NC 27361  
Attn: Contract Government Sales  
Joyce Hill-Customer Service  
(336)472-4044  
jhill@thomasville.com
  - f. Remittance Address:

Thomasville Furniture Ind. Inc.  
P.O. Box 536904  
Atlanta, GA 30353-6823

**The following companies  
have GSA contracts:**

*Thomasville Furniture*

[www.contract.thomasville.com](http://www.contract.thomasville.com)

**Household & Quarters Furniture  
& Packaged Room**

**Contract Number: GS-27F-0013J**

**Comprehensive Furniture Management Services**

**Contract Number: GS-29F-0014U**

**AF NAF Contract: F41999-09-D-0035**

**AF Dormitory BPA FA 4452-11-A-0004**

**Navy BPA for SIN 71 200 Dormitory & Quarters,  
Packaged Room & SIN 71 204 Dormitory, Quarters &  
Residential Case Goods & Beds: N00189-11-A-0010**

**Drexel Heritage Furniture**

[www.drexelheritage.com](http://www.drexelheritage.com)

**Contract Number: GS-27F-3028D**

**State Department Only**

**Thomas W. Raftery, Inc.**

**Window Treatments and Bedspreads**

[www.twraftery.com](http://www.twraftery.com)

**Contract Number GS-03F-6019D**

**Arkansas Lighting**

[www.arkansaslamp.com](http://www.arkansaslamp.com)

**Contract Number: GS-03F-0003J**

**Commercial Carpets of America**

**Flooring of all kinds including carpet, vinyl, ceramic tile etc.**

[www.commercialcarpetsofamerica.com](http://www.commercialcarpetsofamerica.com)

**Contract Number: F41999-98-D-630**

**Design Principles**

**Artwork & Accessories, Inc.**

[designprinciplesart.com](http://designprinciplesart.com)

**Contract Number: GS-03F-5094C**

---

The above companies & products are represented by:

Paige Via

For information, quotes, etc. on all of the above companies, please contact:

105 Holman Road

Williamsburg, VA 23185

Telephone: 757.565.2145

Cell: 757.784.3015

Fax: 757.565.9623

[mpaigevia@gmail.com](mailto:mpaigevia@gmail.com)



# Franklin, Drexel and Hickory Springs Complete EFEC Registration

FRANKLIN CORPORATION COMPLETED ITS IMPLEMENTATION OF AHFA'S EFEC environmental management system in March, registering a 1.1 million-square-foot manufacturing facility in Houston, Miss., that includes the company's corporate headquarters.

Additional facilities achieving EFEC registration in March included two Drexel Heritage plants—the beginning of a year-long drive by Furniture Brands to register all its domestic plants—and a Hickory Springs converting facility in Conover, N.C.

EFEC—or “Enhancing Furniture’s Environmental Culture”—is a voluntary program created for the residential furniture industry by AHFA. To achieve registration, companies must:

- Improve management of resources and raw materials;
- Reduce energy and water consumption;
- Reduce waste disposal and associated costs; and,
- Increase recycling efforts.

“Every viable business today is seeking ways to drive down costs in work processes and raw material usage,” notes Franklin Chairman and CEO Hassell Franklin. “It just makes sense to implement a program to measure and reduce (our) environmental impact. EFEC was tailor-made for not only reducing solid waste and water usage in our facilities, but also for increasing our employees’ awareness of environmental issues.”

Since initiating implementation of the EFEC program at the beginning of 2010, Franklin’s Houston facility has reduced its landfill waste by 14 percent—despite working more hours in 2010 than 2009.

“We achieved this by reusing many items in our facility, recycling as many items as possible, and making a push to bale all scrap cardboard throughout the facility,” explains Carl Daniel, safety and environmental director and head of the EFEC management team. By baling 21 percent more cardboard in 2010 over 2009, the company not only reduced its waste-to-landfill but also generated recycling revenue.

“Franklin is also proud of its truck fleet’s fuel economy,”



Daniel continues. “Our logistics department challenged our drivers to reach a 6.5 mile per gallon goal. New trucks with emission control systems designed to improve fuel efficiency and reduce the amount of exhaust were very instrumental in helping our fleet achieve its goal.”

In 2011, the EFEC team is shifting its focus to energy consumption and exploring new ways to improve energy efficiency, as well as ways to reduce water usage.

“The most challenging part of our EFEC journey has been educating our employees,” Daniel notes. “We have over 1,200 employees here at Franklin, and educating them about EFEC proved to be a daunting task. However, we worked hard using handouts, weekly communication meetings, posters and even the recycling stations to give our employees an idea of the importance of being ‘green’ both at work and at home.”

An employee volunteer group helped multiply the EFEC team’s training efforts and proved to be a rich source of ideas for helping to meet the company’s conservation goals.

The EFEC audit includes interviews with randomly selected employees to make sure they understand the EFEC program and the company’s environmental objectives. At the Franklin plant, employees described their smaller efforts to conserve—such as turning off water while washing hands and separating materials for recycling—as well as larger measures, such as grinding wood waste for fuel and adjustments to the HVAC system to conserve energy.

EFEC—which requires participants to make continual improvements in order to retain their registration—is now guiding the environmental efforts at 48 different furniture manufacturing and administrative locations operated by 18 companies in 11 states.

The first Furniture Brands company to achieve EFEC registration was Hickory Chair in 2008. A Thomasville plant in Lenoir, N.C., was registered in 2010. David Stout, FBN’s director of environmental compliance, says a warehouse in High Point and four Lane Furniture plants in Tupelo, Miss., will likely be the next FBN locations to achieve registration.

The Hickory Springs facility is the first of more than 30 furniture foam, metal and spring component plants the company intends to have EFEC-registered. ★

“Every viable business today is seeking ways to drive down costs in work processes and raw material usage.”

*Hassell Franklin,  
Chairman and CEO,  
Franklin Corp.*



- [Home](#)
- [Sustainable by Design Overview](#)
- [Program Governance](#)
- [SBD Guidance](#)
- [Annual Sustainability Report](#)
- [SBD Registered Manufacturers](#)
- [SBD Suppliers](#)
- [SBD News](#)
- [EFEC](#)
- [Resources](#)
- [Contact Us](#)

**EFEC (Enhancing Furniture's Environmental Culture)**



EFEC is a voluntary environmental management system created by AHFA in 1999 to help its members develop and maintain strong, proactive environmental programs.

EFEC provides a systematic approach for reviewing and improving your company's operations for better environmental performance and improved profitability. In addition, many states now offer specific benefits for companies with an environmental management system in place. These benefits may include less reporting, fewer inspections, permit flexibility, faster permit approvals, government recognition and reduced permit and application fees.

EFEC registration requires a company to analyze the environmental impact of its operations, raw materials and finished products on a facility-by-facility basis. Measurable benefits include:

- Better management of resources and raw materials;
- Reduced energy and water consumption;
- Reduced waste disposal and associated costs; and,
- Improved overall operational performance and efficiency.

All of a company's domestic facilities, including headquarters buildings and warehouses in addition to factories, must be EFEC-registered to proceed with AHFA's Sustainable by Design program.

For more information on beginning the EFEC program, contact Bill Perdue, [bperdue@ahfa.us](mailto:bperdue@ahfa.us).

**THE FOLLOWING COMPANIES HAVE EFEC REGISTERED FACILITIES:**

**DREXEL HERITAGE**

DREXEL HERITAGE  
Plant 60  
EFEC Registered  
March 2011

**FRANKLIN CORPORATION**

FRANKLIN CORPORATION  
Corporate Headquarters  
Manufacturing Plant, Houston, MS  
EFEC Registered  
March 2011



**BRADINGTON-YOUNG**

BRADINGTON-YOUNG  
EFEC Registered  
June 2009



**HAMMARY\***

STYLE | VALUE | SERVICE

HAMMARY FURNITURE  
EFEC Registered  
June 2009

**L A Z B O Y'**

LA-Z-BOY RESIDENTIAL  
Newton, MS - Dimension Mill, Plant 2  
Siloam Springs, AR; Neosho, MO; Dayton, TN;  
LZB West - Redlands, CA

EFECE Registered  
June 2009



Tradition. Innovation. Performance.  
WORLDWIDE

HICKORY SPRINGS MANUFACTURING  
Converting Facility, Conover, NC  
EFECE Registered  
March 2011



SAM MOORE FURNITURE  
Bedford, VA, Plant & Office  
EFECE Registered  
May 2009



THOMASVILLE FURNITURE  
Plant 25, Lenoir, NC  
EFECE Registered  
November 2010



FAIRFIELD  
FAIRFIELD CHAIR  
Plants 1, 2 & Corporate Office, Lenoir, NC  
EFECE Registered  
February 2009



CRAFTMASTER  
EFECE Registered  
July 2010



AMERICAN DREW  
Plants 13 & 14  
EFECE Registered  
September 2008



LEGGETT & PLATT  
HP Furniture Components  
Branch 5801 - No Sag Products  
EFECE Registered  
March 2010  
Plant 8814 - L&P Distribution Center  
Branch 331 - Ark-Ell Spring  
Branch 341 - Tupelo Sleeper  
Branch 548 - Petco/Sackner  
EFECE Registered  
December 2010



C.R. LAINE  
EFECE Registered  
September 2008

HICKORY CHAIR



HICKORY CHAIR COMPANY  
EFECE Registered  
September 2008



BASSETT FURNITURE  
Newton, N.C. Upholstery Plant  
EFECE Registered  
October 2009  
Main Office, Martinsville Table Plant & Warehouse  
EFECE Registered  
September 2010



KINCAID & KINCAID UPHOLSTERY  
Plants 1, 6 & 9  
Taylorsville Upholstery Facility Plant 21  
EFECE Registered  
September 2008

  
**HOOKER**  
 FURNITURE  
*Easy Elegance • Since 1924*  
**HOOKER FURNITURE**  
 Corporate Office, Customer Service Support Center,  
 Cloverleaf Warehouse, Central Distribution Center  
**EPEC Registered**  
 September 2009

**Lea**<sup>®</sup>  
*The Youth Specialist*  
 A LABOV BRAND  
**LEA INDUSTRIES**  
 Plants 13 & 14  
**EPEC Registered**  
 September 2008

---

**CENTURY FURNITURE**

---

**CENTURY FURNITURE**  
 Plant 3 Upholstery Campus  
**EPEC Registered**  
 May 2009  
 Plants 1 Caseloads & Plant 2 Upholstery  
**EPEC Registered**  
 August 2009

**Vaughan-**  
 furniture company **Bassett**  
**VAUGHAN-BASSETT**  
 Elkin Plant, Galax Plant & Corporate Office  
**EPEC Registered**  
 July 2008

  
**FURNITURE, INC.**  
**DMI FURNITURE**  
 Corp. Office, Plant 5 and Warehouse  
**EPEC Registered**  
 August 2009

**BERNHARDT**  
**BERNHARDT FURNITURE**  
 Plants 2, 3, 6, 7 & Corporate Office, Lenoir, NC  
**EPEC Registered**  
 March 2008

  
**Flexsteel**<sup>®</sup>  
 America's Seating Specialist  
**FLEXSTEEL**  
 Dublin, GA; Dubuque, IA (Plant & Corp. Office);  
 Riverside, CA; Harrison, AR; and Starkville, MS  
**EPEC Registered**  
 August 2009

---

YOU CAN TAKE CARE OF THE PLANET WHILE YOU DO BUSINESS